

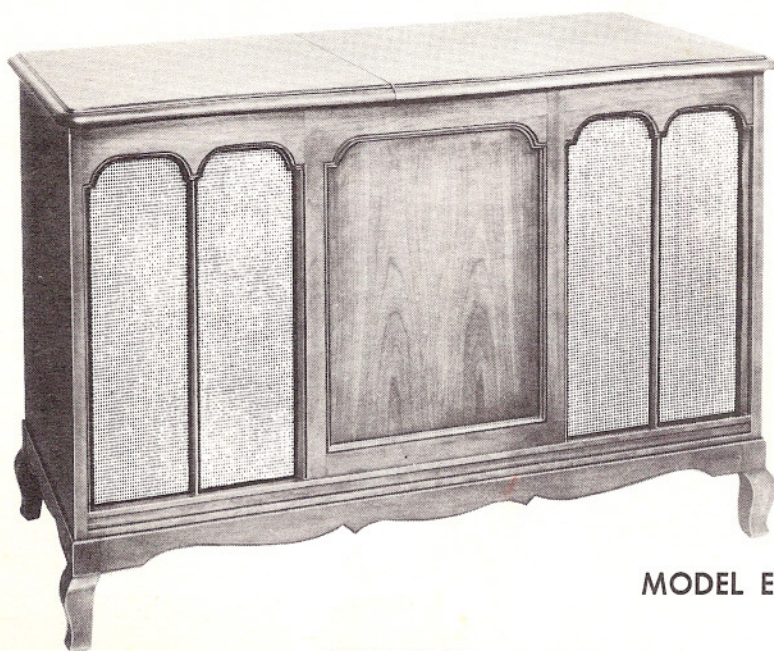

Stereophonic

THE FISHER CUSTOM ELECTRA V SERVICE MANUAL



MODEL E-46X

PRICE: \$1.00

FISHER RADIO CORPORATION • NEW YORK



THE FISHER E-46X



PARTS DESCRIPTION LIST

CAPACITORS

10% tolerance for all fixed capacitors, unless otherwise noted or marked GMV (guaranteed minimum value). All capacitors not marked uf are pF (uuf).

Symbol	Description	Part No.
C3	Ceramic, 21, 5%, N750, 1000V	C50070-32
C4	Ceramic, 3, NPO, 1000V	C50070-28
C5	AM Variable	C812-118
C6	Ceramic, 1000, GMV, 1000V	C50071-2
C9	Ceramic, 100, GMV, N1500, 1000V	C50070-5
C10, 11	Ceramic, .01uf, 20%, 500V	C50089-3
C12	Ceramic, Feedthru, 1000, GMV	C592-187
C13, 14	Ceramic, .02uf, +80 — 20%, 500V	C50089-4
C15, 16	Mylar, .022uf, 400V	C50197-28
C17	Ceramic Trimmer	C662-123
C18	FM Variable	C818-116
C19	Ceramic, 2.2, 500V	C3039
C20	Ceramic, 1000, GMV, 1000V	C50071-2
C21	Ceramic, 8, ±.5, NPO, 500V	CC20CJ080D5
C22	Ceramic, 5, NPO, 1000V	C50070-24
C23	Ceramic, 33, 5%, N750, 1000V	C50070-25
C24	Ceramic, 100, GMV, N1500, 1000V	C50070-5
C25	Ceramic, 24, 5%, N150, 1000V	C50070-8
C26	Ceramic, 47, 5%, N150, 1000V	C50070-29
C27	Ceramic, 8, ±.5, NPO, 500V	CC20CJ080D5
C28	Ceramic, 100, 5%, N1500, 1000V	C50070-19
C29	Ceramic, 10, ±.5, N150, 500V	CC20PJ100D5
C30	Ceramic, 1000, 1000V	C50072-3
C31	Ceramic, Feedthru, 1000, GMV	C592-187
C32	Ceramic, 5000, 20%, 500V	C50089-1
C35	Ceramic, 100, GMV, N1500, 1000V	C50070-5
C36	Ceramic, 10, NPO, 1000V	C50070-11
C37, 38	Ceramic, 33, N750, 1000V	C50070-15
C39	Ceramic, 5000, 20%, 500V	C50089-1
C40	Ceramic, .68, 500V	C50077-6N
C41	Ceramic, .02uf, +80 — 20%, 500V	C50089-4
C42, 43	Ceramic, 5000, 20%, 500V	C50089-1
C44	Ceramic, 2700, 1000V	C50072-17
C45	Ceramic, 5000, 20%, 500V	C50089-1
C46	Ceramic, .68, 500V	C50077-6N
C47	Ceramic, .02uf, +80 — 20%, 500V	C50089-4
C48, 49,		
50, 51	Ceramic, 5000, 20%, 500V	C50089-1
C52	Ceramic, 2700, 1000V	C50072-17
C53	Ceramic, 5000, 20%, 500V	C50089-1

C54	Ceramic, 100, N1500, 1000V	C50070-6
C55	Mylar, .047uf, 250V	C50197-52
C56	Ceramic, .02uf, 20%, 500V	C50089-5
C57	Ceramic, 470, 1000V	C50072-13
C58	Ceramic, 68, N2200, 1000V	C50070-12
C59	Ceramic, .02uf, 20%, 500V	C50089-5
C60	Ceramic, 470, 1000V	C50072-13
C61	Ceramic, 68, N2200, 1000V	C50070-18
C62, 63	Ceramic, 470, 1000V	C50072-13
C68	Ceramic, 2700, 1000V	C50072-17
C69	Ceramic, 5000, 20%, 500V	C50089-1
C70	Ceramic, 330, 1000V	C50072-1
C71	Ceramic, 1800, 1000V	C50072-8
C72	Electrolytic, 2 Section: A — 20uf, 300V B — 40uf, 400V	C50180-22
C73, 74	Ceramic, 330, 1000V	C50072-1
C75	Ceramic, .05uf, +80 — 20%, 100V	C50073-2
C77	Ceramic, 5000, 20%, 500V	C50089-1
C78	Ceramic, .01uf, 20%, 500V	C50089-3
C79	Ceramic, 5000, 20%, 500V	C50089-1
C80	Ceramic, Feedthru, 1000, GMV	C592-187
C81	Electrolytic, 8uf, 50V	C629-138
C82	Ceramic, 5000, 20%, 500V	C50089-1
C83	Ceramic, .01uf, 20%, 500V	C50089-3
C84	Ceramic, 5000, 20%, 500V	C50089-1
C86	Ceramic Trimmer	C662-123

RESISTORS

In ohms, 10% tolerance, 1/2 watt unless otherwise noted. K=Kilohms. M=Megohms.

Symbol	Description	Part No.
R1	Composition, 270	RC20BF271K
R4, 5	Dep. Carbon, 5%, 1/3 W	R33DC104J
R6	Dep. Carbon, 47K, 5%, 1/3 W	R33DC473J
R7	Composition, 10	RC20BF100K
R8	Dep. Carbon, 47K, 5%, 1/3 W	R33DC473J
R9	Composition, 10	RC20BF100K
R10	Dep. Carbon, 10K, 5%, 1/3 W	R33DC103J
R11	Dep. Carbon, 2.7K, 5%, 1/3 W	R33DC272J
R12	Dep. Carbon, 10K, 5%, 1/3 W	R33DC103J
R13	Dep. Carbon, 2.7K, 5%, 1/3 W	R33DC272J
R14	Composition, 100K	RC20BF104K
R16	Composition, 820K	RC20BF824K
R17, 18	Dep. Carbon, 330K, 5%, 1/3 W	R33DC334J

PARTS DESCRIPTION LIST

R19	Composition, 100	RC20BF101K	R77	Dep. Carbon, 47K, 5%, 1/3 W	R33DC473K
R20, 21	Composition, 4.7M	RC20BF475K	R78	Potentiometer, 500K, Balance Control	R50160-97
R22	Composition, 470	RC20BF471K	R79, 80	Dep. Carbon, 22K, 5%, 1/3 W	R33DC223J
R23, 24	Dep. Carbon, 220K, 5%, 1/3 W	R33DC224J	R81	Composition, 68K	RC20BF683K
R25	Composition, 27K	RC20BF473K	R82	Potentiometer, 500K, Volume Control	R50160-54
R26, 27	Dep. Carbon, 100K, 5%, 1/3 W	R33DC104J	R83	Composition, 1K	RC20BF102K
R28	Composition, 820	RC20BF821K	R84	Composition, 270	RC20BF271K
R29	Composition, 820K	RC20BF824K	R85	Dep. Carbon, 47K, 5%, 1/3 W	R33DC473J
R30	Composition, 150K	RC20BF154K	R86	Composition, 100K	RC20BF104K
R31	Dep. Carbon, 22K, 5%, 1/3 W	R33DC223J	R87	Composition, 22K	RC20BF223K
R32, 33	Composition, 1K	RC20BF102K	R88	Composition, 1.5K	RC20BF152K
R34	Composition, 18K, 1W	RC30BF183K	R89	Composition, 1K	RC20BF102K
R35	Composition, 100	RC20BF101K	R90	Composition, 15K	RC20BF153K
R36	Dep. Carbon, 470K, 5%, 1/3 W	R33DC474J			
R37	Composition, 5.6M	RC20BF565K			
R38	Dep. Carbon, 470K, 5%, 1/3 W	R33DC474J			
R39	Composition, 5.6M	RC20BF565K			
R40, 41	Dep. Carbon, 2.2M, 5%, 1/3 W	R33DC225J			
R42	Composition, 100K	RC20BF104K			
R43	Composition, 560	RC20BF561K			
R44	Composition, 100K	RC20BF104K			
R45	Composition, 560	RC20BF561K			
R46	Composition, 150	RC20BF151K			
R47, 48	Composition, 220K	RC20BF224K			
R49	Composition, 47K	RC20BF473K			
R50	Composition, 1K	RC20BF102K			
R51	Composition, 180	RC20BF181K			
R52, 53	Potentiometer, 1M, Treble & Bass	R50160-55			
R54, 55	Composition, 39K	RC20BF393K			
R56	Composition, 150	RC20BF151K			
R57	Composition, 27K	RC20BF273K			
R58	Composition, 1K	RC20BF102K			
R59	Composition, 180K	RC20BF184K			
R60	Composition, 82K	RC20BF823K			
R61, 62	Composition, 220K	RC20BF224K			
R63	Composition, 47K	RC20BF473K			
R64	Composition, 2.2M	RC20BF225K			
R65	Composition, 100K	RC20BF104K			
R66	Composition, 560	RC20BF561K			
R67	Composition, 390K, 5%	RC20BF394J			
R68	Composition, 100K	RC20BF104K			
R69	Composition, 560	RC20BF561K			
R70	Composition, 390K, 5%	RC20BF394J			
R71	Composition, 1K	RC20BF102K			
R72, 73	Dep. Carbon, 47K, 5%, 1/3 W	R33DC473J			
R75, 76	Composition, 8.2M, 5%	RC20BF825J			

CHOKES, COILS & TRANSFORMERS		
Symbol	Description	Part No.
L1	AM Loop Antenna	L50210-26
L2	FM Antenna Coil	L818-113
L3	Choke, 1.5 Microhenries	L50066-4
L4	Choke, RF	L629-180
L5	FM RF-Coil	L818-114
L6	FM Oscillator Coil Ass'y	AS818-118
L7	Choke, .68 Microhenries	L50066-1
L8	Choke, .2 Microhenries	L50066-21
L9	AM Oscillator Coil	L50210-22
L10, 11, 12, 13, 14, 15, 16, 17	Choke, Filament, Ferrite Bead	L592-189
L18	Choke, 3.3 Microhenries	L50066-8
Z1	FM IF Transformer	ZZ662-117
Z2	FM IF Transformer	ZZ2987
Z3	FM Limiter Coil Ass'y	L670-145
Z4	FM Ratio Detector Transformer	ZZ50210-9
Z5	AM IF Transformer	L50210-23
Z6, 7	AM IF Transformer	ZZ2984

MISCELLANEOUS		
Symbol	Description	Part No.
I1,2	Dial Lamp	I50082-8
PC1, 2	Printed Circuit, Phono Equalization	PC50187-3
PC3, 4	Printed Circuit, Tone Control	PC50187-4
S1	Switch, Selector	S904-120
S2	Switch, Power	Part of R82
S3	Switch, Automatic Shutoff	Part of R78
—	Dial, Glass	N812-126
—	Dial Pointer	A50242-5

ALIGNMENT INSTRUCTIONS

Read These Instructions With Extreme Care Before Attempting Alignment.

CHASSIS: Turn the station selectors completely counterclockwise, without forcing. Dial pointers should be at zero index mark on logging scale. If not, reset the dial pointers. Disconnect the external antennas and the antenna link. (Set Volume Control to minimum (CCW.)

When using an oscilloscope for alignment, set the output level controls for no overload, as shown by the proper waveform shape.

SIGNAL GENERATORS: The signal generator equipment must be able to supply the following:

FM RF modulated 30% (\pm 22.5 KC deviation) at 400 cps; AM RF modulated 30% at 400 cps;

INDICATOR: DC VTVM, AC VTVM, and scope for alignment filter adjustment.

ALIGNMENT: Allow the chassis and test instruments to warm up for at least fifteen minutes. Adjust the line voltage for 117 volts AC, 50-60 cycles. Use fully insulated tools: a small screwdriver for all trimming capacitors; a K-Tran tool for Z1, Z2, Z5, Z6 and Z7; a hex tool for Z3, Z4, L2, L5, L6 and L9. For AM alignment, short junction of C55 and R64 to ground.

AM ALIGNMENT

STEPS	CHASSIS		SIGNAL GENERATOR			INDICATOR		ALIGNMENT	
	SELECTOR	STATION SELECTOR	COUPLING	FREQ.	MOD.	TYPE	CONNECTION	ADJUST	INDICATION
1	AM	Point of no signal and no interference	AM Gen. connected thru .01-uf cap. to V6, Pin 7	455 KC	30% AM at 400 cps	AC VTVM to Ch. B	RCRDR Output	Z6, Z7 top and bottom	Maximum voltage
2	AM	600 KC	AM Gen. connected thru 220-uuf cap. to antenna terminal 4 Disconnect link between 4 & 5	600 KC	30% AM at 400 cps	AC VTVM to Ch. B	RCRDR Output	L9, Z5 L1	Maximum voltage
3	AM	1400 KC	AM Gen. connected thru 220-uuf cap. to antenna terminal 4 Disconnect link between 4 & 5	1400 KC	30% AM at 400 cps	AC VTVM to Ch. B	RCRDR Output	C5E, C5C C5A	Maximum voltage
4	Repeat steps 2 and 3 for proper dial calibration and maximum output.								
5	FM	Point of no signal and no interference	FM Gen. connected thru 2.2-uuf cap. to test point 1	10.7 MC	None	DC VTVM to test point 2		Z1, Z2, Z3 and Z4, top & bottom	Maximum positive voltage
6	FM	Point of no signal and no interference	FM Gen. connected thru 2.2-uuf cap. to test point 1	10.7 MC	None	Connect two 47K ohm resistors in series across C81. Connect a VTVM between the junction of the two 47K ohm resistors and test point 3		Z4 top	Zero reading on zero center scale
7	FM	90 MC	FM Gen. connected thru two 120-ohm carbon resistors to antenna terminals 2 and 3	90 MC	30% FM (22.5 KC Dev.) at 400 cps	DC VTVM to test point 2 and scope to Ch. A	RCRDR Output	L6, L5, L2	Check for sine waveform and adjust for maximum positive voltage
8	FM	106 MC	FM Gen. connected thru two 120-ohm carbon resistors to antenna terminals 2 and 3	106 MC	30% FM (22.5 KC Dev.) at 400 cps	DC VTVM to test point 2 and scope to Ch. A	RCRDR Output	C86 and C17	Check for sine waveform and adjust for maximum positive voltage
9	Repeat steps 7 and 8 at least once for proper dial calibration and maximum output.								
NOTE: For calibrating both the AM and FM, use as low an output voltage as possible from your signal generator.									

FM ALIGNMENT

SCHEMATIC DIAGRAM • CHASSIS 460-T

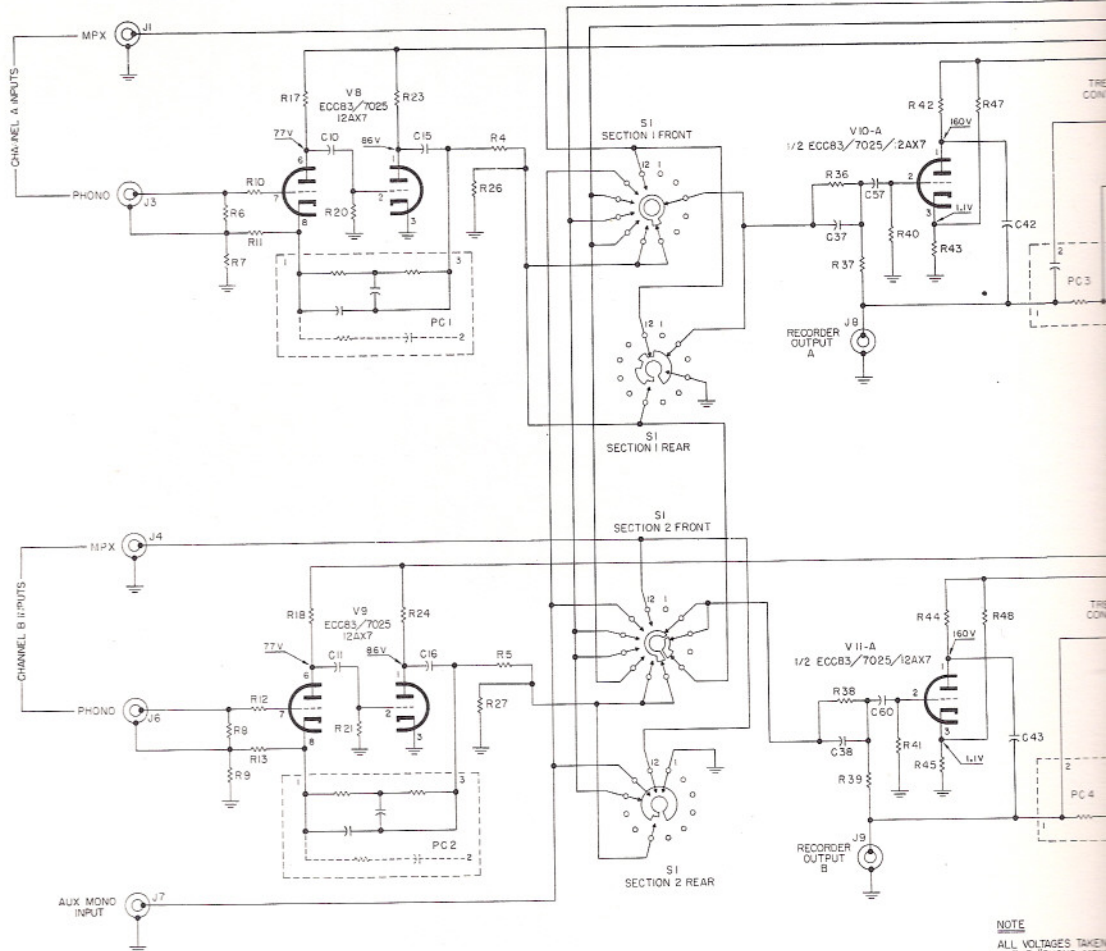
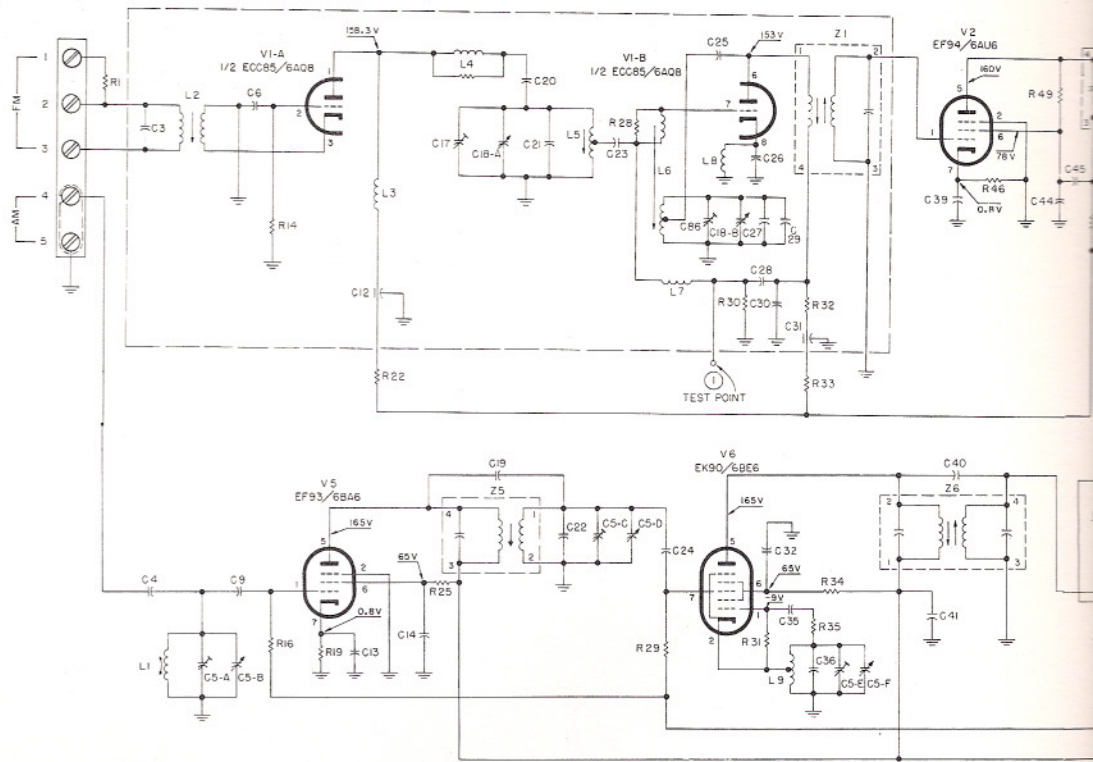

NOTE
ALL VOLTAGES TAKEN
IN THE PHONO-MONO
ANTENNA TERMINAL

RESISTORS	R1	R6 TO R9	R10 TO R13	R14 TO R18	R19 TO R21	R22 TO R24	R25	R26 TO R27	R4	R5	R28	R29	R30	R31	R32 TO R33	R40	R41	R42 TO R45	R46	R47	R48	R49																					
CAPACITORS	C3	C4	C5-A	C5-B	C6	C9	C10	C11	C12	C13	C14	C15	C16	C17	C18-A	C19	C20	C21	C22	C23	C24	C25	C18-B	C26	C27	C28	C29	C30	C31	C32	C33	C34	C35	C36	C37	C38	C39	C40	C41	C42	C43	C44	C45

PARTS DESCRIPTION LIST • AMPLIFIER

CAPACITORS

10 % tolerance for all fixed capacitors, unless otherwise noted or marked GMV (guaranteed minimum value). All capacitors not marked uf are pF (uuf).

Symbol	Description	Part No.
C91, 92	Ceramic, 3, NPO, 1000V	C50070-28
C93	Electrolytic, 3 Section: A — 100uf, 100V B — 60uf, 250V C — 60uf, 250V	C50180-17
C94, 95, 96, 97	Mylar, .047uf, 400V	C50197-30
C98	Electrolytic, 3 Section: A — 40uf, 450V B — 40uf, 450V C — 100uf, 250V	C50180-23
C99	Ceramic, 18, N470, 1000V	C50070-13
C100	Ceramic, 150, 1000V	C50072-18
C101	Ceramic, 18, N470, 1000V	C50070-13
C102	Ceramic, 150, 1000V	C50072-18
C103	Electrolytic, 100uf, 250V	C50180-15
C104, 105	Ceramic, 330, 1000V	C50072-1
C106, 107	Molded, .01uf, 20 % , 600V	C2747

RESISTORS AND POTENTIOMETERS

In ohms, 10 % tolerance, 1/2 watt, unless otherwise noted. K=Kilohm, M=Megohm.

Symbol	Description	Part No.
R96, 97	Composition, 68K, 5 %	RC20BF683J
R98	Composition, 680K	RC20BF684K
R99	Dep. Carbon, 3.9K, 5 % , 1/3 W	R33DC392J
R100	Dep. Carbon, 220, 5 % , 1/3 W	R33DC221J
R101	Composition, 680K	RC20BF684K
R102	Dep. Carbon, 3.9K, 5 % , 1/3 W	R33DC392J
R103	Dep. Carbon, 220, 5 % , 1/3 W	R33DC221J
R104	Composition, 18K	RC20BF183K
R105, 106, 107, 108	Dep. Carbon, 47K, 5 % , 1/3 W	R33DC473J
R109	Potentiometer, 5K, Bias	R50103-4
R110	Composition, 2.2K, 1W	RC30BF22K
R111, 112	Composition, 220	RC20BF221K
R113	Dep. Carbon, 2.7K, 5 % , 1/3 W	R33DC272J
R114, 115	Dep. Carbon, 330K, 5 % , 1/3 W	R33DC334J
R116, 117, 118	Dep. Carbon, 2.7K, 5 % , 1/3 W	R33DC272J
R119, 120	Dep. Carbon, 330K, 5 % , 1/3 W	R33DC334J
R121, 122	Dep. Carbon, 2.7K, 5 % , 1/3 W	R33DC272J
R123	Composition, 2.2K, 2W	RC40BF222K
R124	Glass, 220, 3W	RPG3W221K
R125	Composition, 4.7K	RC20BF472K
R126	Glass, 2.2K, 7W	RPG7W222K
R127	Glass, 220, 3W	RPG3W221K
R128	Composition, 820K	RC20BF824K

MISCELLANEOUS

Symbol	Description	Part No.
T1	Transformer, Output, Channel A	T812-217-1
T2	Transformer, Output, Channel B	T812-217-2
T3	Transformer, Power	T812-215
CR3, 4	Silicon Diode	SR806-126
F1	Fuse, 3.2A, Slo-Blo	F3319
J15	Jack, Power	X905-113
J20	Socket, Record Changer	X905-115

SCHEMATIC DIAGRAM • AMPLIFIER

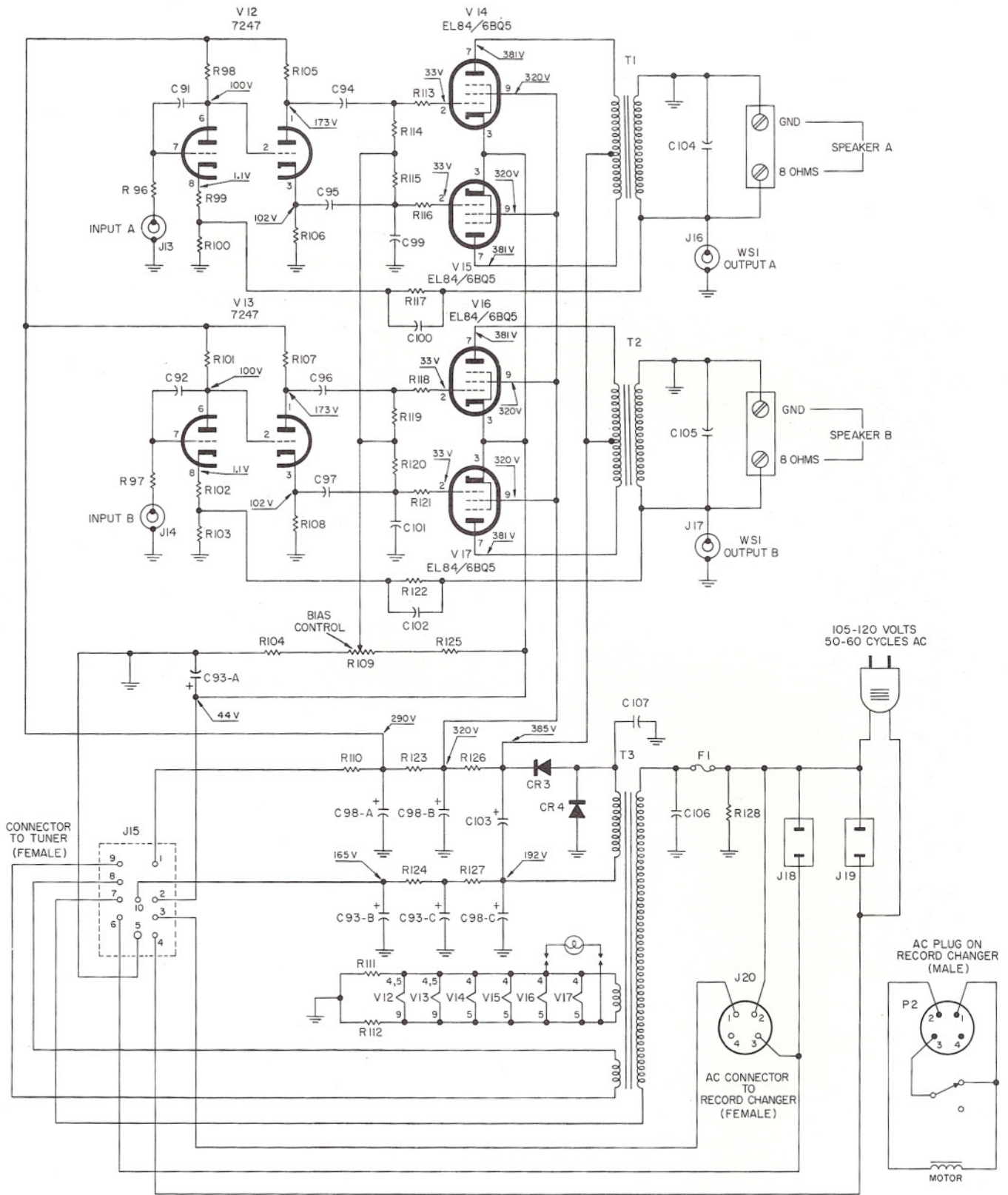

AW # 1896
P905-SCHEMATIC

RESISTORS	R96 R97	R98 TO R103	R104 R105 TO R108	R109 TO R112	R113 TO R124	R125 R126 R127	R128
CAPACITORS	C91 C92	C93-A	C94 C98-A TO C93-B C97	C99 C98-B TO C93-C C102	C103 C98-C	C107	C104 C105 C106

TUBE LAYOUT

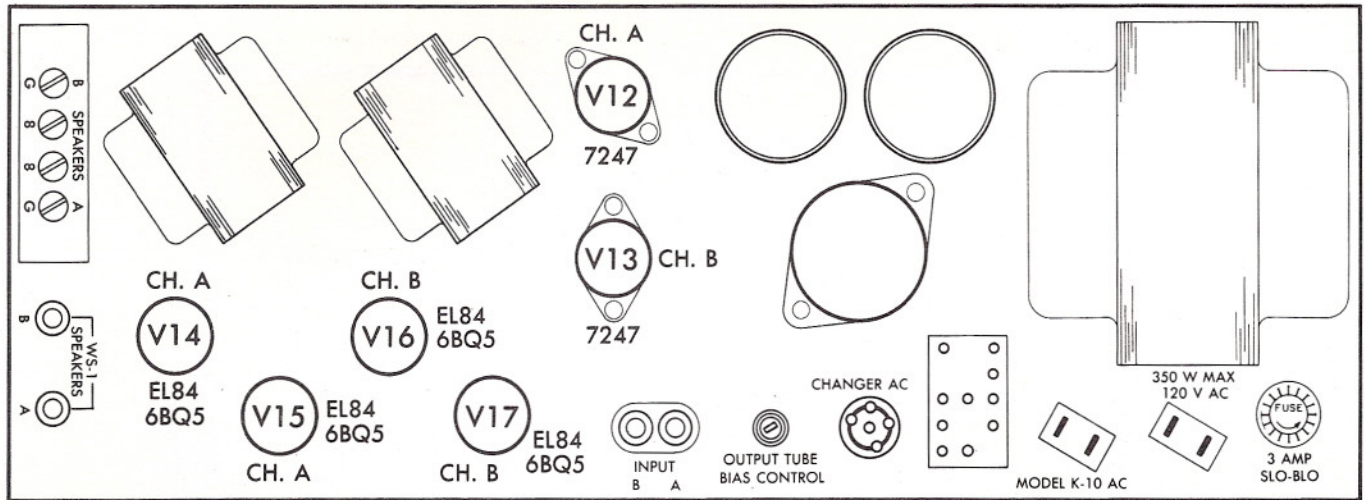

AW # 1903

AMPLIFIER

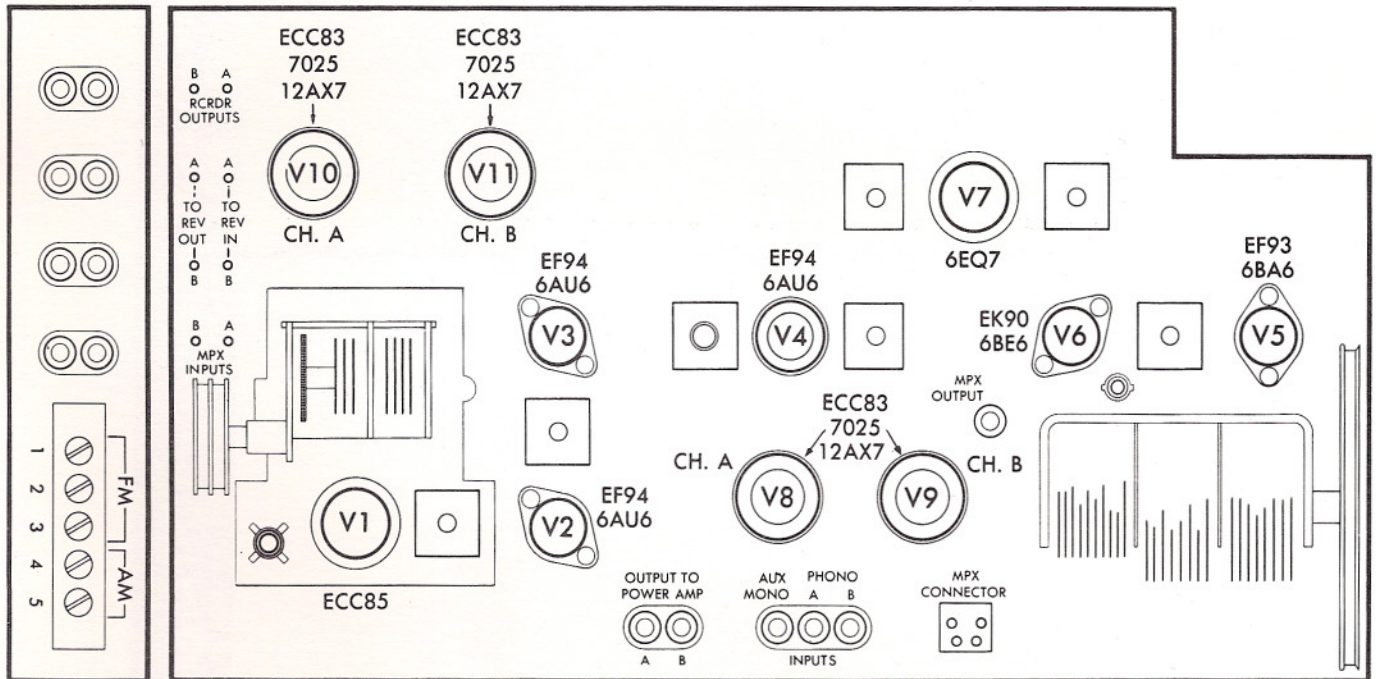

AW # 1905

TUNER AND PREAMPLIFIER

SCHEMATIC DIAGRAM • SPEAKER SYSTEMS

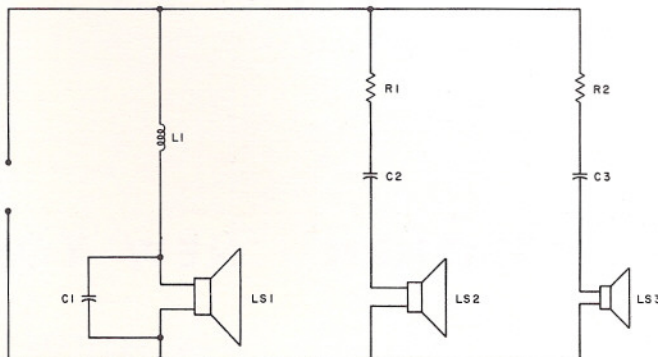

INS-107

PARTS DESCRIPTION LIST • SPEAKER SYSTEMS

Symbol	Description	Part No.
C1	Capacitor, Electrolytic, non-polarized, 4uf, 20%, 50V	C831-107
C2	Capacitor, 2uf, 50V	C547-118
C3	Capacitor, .47uf, 10%, 200V	C68P474K2
L1	Coil, 3 MH.	L547-120
LS1	Speaker, 12-inch, woofer, 8 ohms	LS910-104
LS2	Speaker Midrange, Oval	LS830-106
LS3	Speaker, tweeter,	LS830-107
R1	Resistor, wirewound, 12 ohms, 10%, 5W	R721-141
R2	Resistor, wirewound, 30 ohms, 10%, 5W	R689-103

SCHEMATIC DIAGRAM • MULTIPLEX SECTION

CAPACITORS

10 % tolerance for all fixed capacitors, unless otherwise noted or marked GMV (guaranteed minimum value). All capacitors not marked uf are pF (uuf).

Symbol	Description	Part No.
C200	Ceramic, .01uf, +80 —20%, 500V	C50089-7
C201	Ceramic, 680, 1000V	C50072-2
C203	Ceramic, 220, 1000V	C50183-3
*C204	Mica, 470, 5%, 300V	C50332-4
C205	Ceramic, 82, N1500, 1000V	C50070-7
C206	Ceramic, 1000, GMV, 500V	C50089-2
C207	Electrolytic, 1uf, 350V	C50283-3
*C208, 209	Mica, 4700, 5%, 500V	C50332-5
C210	Electrolytic, 1uf, 350V	C50283-3
C211	Ceramic, 1000, GMV, 500V	C50089-2
C214	Mylar, 4700, 400V	C50197-25
*C215	Mica, 3900, 5%, 500V	C50332-6
C216, 217,		
218	Ceramic, 5000, 20%, 500V	C50089-1
C219	Ceramic, 330, 1000V	C50072-1
C220	Ceramic, 5000, 20%, 500V	C50089-1
C221, 222	Ceramic, .02uf, +80 —20%, 500V	C50089-4
C223, 224	Ceramic, 1000, 1000V	C50072-3
C225, 226	Ceramic, 2200, 1000V	C50072-5

RESISTORS

In ohms, 10% tolerance, 1/2 watt unless otherwise noted. K=Kilohms. M=Megohms.

Symbol	Description	Part No.
R200	Composition, 22M	RC20BF226K
R201	Composition, 4.7K, 5%	RC20BF472J
R202	Composition, 15K, 5%	RC20BF153J
R203	Composition, 10M	RC20BF106K
R204	Composition, 15K, 5%	RC20BF153J
R205	Dep. Carbon, 330K, 5%, 1/3 W	R33DC334J
R206	Dep. Carbon, 1M, 5%, 1/3 W	R33DC105J
R208	Dep. Carbon, 22K, 5%, 1/3 W	R33DC223J
R209, 210,		
211, 212	Composition, 33K, 5%	RC20BF333J
R213, 214	Dep. Carbon, 100K, 5%, 1/3 W	R33DC104J
R215	Potentiometer, 50K, MPX Sep't'n Control	R50150-4
R216	Composition, 22M	RC20BF226K
R217, 218	Dep. Carbon, 18K, 5%, 1/3 W	R33DC183J
*R219, 220	Dep. Carbon, 15K, 5%, 1/3 W	R33DC153J
R221	Composition, 22M	RC20BF226K
R222, 223,		
224, 225	Dep. Carbon, 22K, 5%, 1/3 W	R33DC223J
*R226, 227,		
228, 229,		
230	Dep. Carbon, 1M, 5%, 1/3 W	R12DC105J

MISCELLANEOUS

Symbol	Description	Part No.
*CR102, 103	Diodes, Type 1112	V-1112
L100	Coil, Low Pass	L50210-30
L102, 103	Coil, 20 Microhenries, 5%	L50334-2
*Z100	Transformer, 19Kc	ZZ50210-34
*Z101	Coil, 38Kc	ZZ50210-33

***NOTE:** On some units C204 may be a 220 pF capacitor, if so there is an additional 220 pF capacitor from Pin 1 of V100 to chassis.
 Z100 may use the Part #ZZ50210-13 or ZZ50210-13X, if so C208 and 209 may be a 5100 pF or 3900 pF Mica Capacitor.
 Z101 may use the Part #ZZ50210-14, if so C215 will be a 5100 pF or 4700 pF Mica Capacitor.

CR102, 103 on some models may use Diode Type 1N294A.

R226 through 230 may be omitted on some units.

R219 and 220 may be 12K on some units.

Note: If replacement of any of the above parts is required, use the part as found in unit.

SCHEMATIC DIAGRAM • MULTIPLEX SECTION

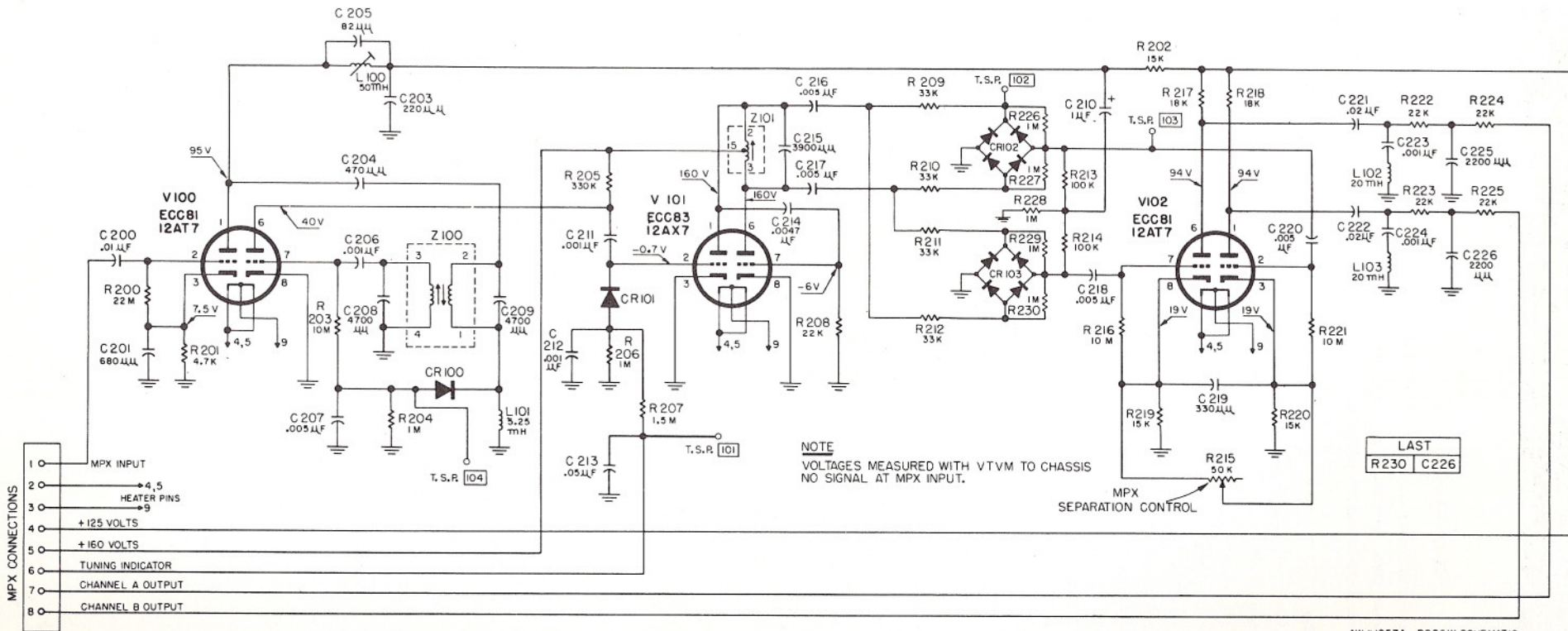

TUBE LAYOUT

MPX-70 CHASSIS

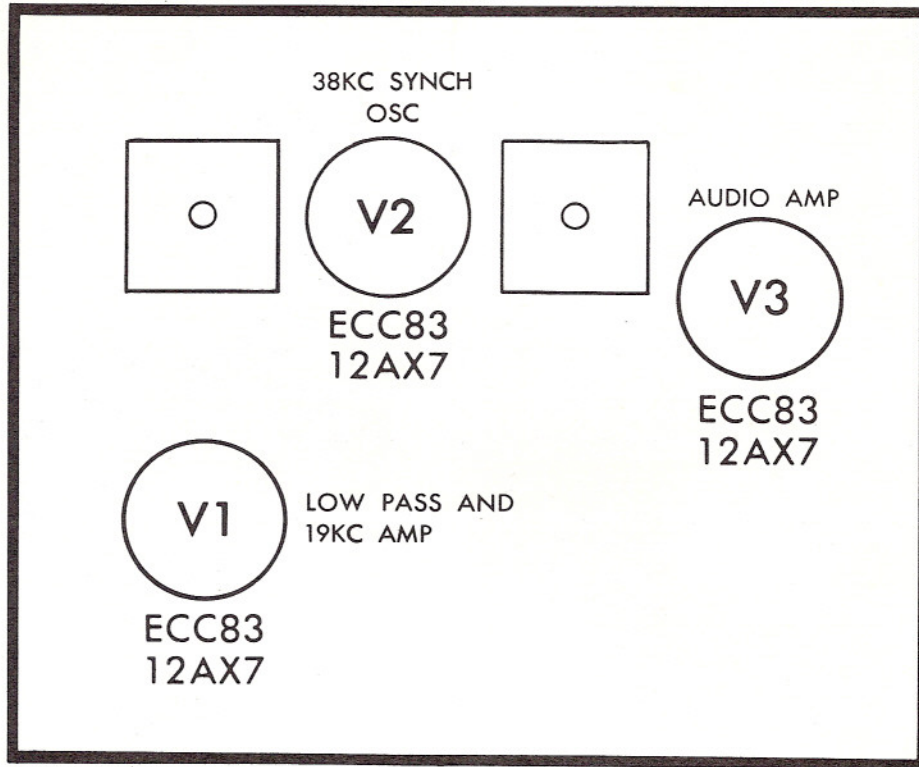

AW1965



FISHER RADIO CORPORATION • NEW YORK

N910-103

©1962 FISHER RADIO CORPORATION

PRINTED IN U. S. A.

403-W12½C-12