



THE FISHER®

Custom Electra II

RADIO PHONOGRAPH

Model K-100

SERVICE MANUAL

PRICE: \$1.00

FISHER RADIO CORPORATION • NEW YORK

ALIGNMENT INSTRUCTIONS: READ WITH EXTREME CARE BEFORE ATTEMPTING ALIGNMENT. To set pointer, turn the tuning capacitor fully closed and set pointer to last reference mark at low frequency end of dial. Use an insulated screwdriver for alignment adjustment.

STEPS	DUMMY ANTENNA	COUPLING	FREQUENCY	MODULATION	BAND SWITCH SETTING	DIAL POINTER SETTING	INDICATING METER	ADJUST	REMARKS
1	.01 mfd	Pin 7 (Grid) V7 (6BE6)	455 Kc	400 cps AM	AM	1000 Kc (Approx.)	AC Voltmeter to speaker out- put terminals and 16 ohm load	Z-5, Z-6 Top and Bottom	Adjust for maximum deflection.
2	200 mmfd	AM Terminals on antenna strip	1400 Kc	"	AM	1400 Kc	"	C-1L, C-1J, C-1G	" "
3	"	"	600 Kc	"	AM	600 Kc	"	L-9, L-8	" "
4	Repeat steps 2 and 3								
5	—	To shield of V2 (6U8) Un- ground shield	10.7 Mc	None	FM	Point of no interference	DC VTVM to junction of R-29 and R-30	Z-1, Z-2, Z-3, Top and Bottom and Bottom of Z-4	Adjust for maximum negative voltage
6	—	"	"	None	FM	"	DC VTVM to junction of C-27 and R-24*	Z-4 Top	Adjust for zero between positive and negative readings †
7	270 ohm carbon resistor	FM Terminals on antenna strip	106 Mc	400 cps FM (22.5 KC deviation)	FM	106 Mc	DC VTVM to junction of R-29 and R-30	C-16	Adjust for maximum negative voltage
8	"	"	90 Mc	"	FM	90 Mc	"	L-6	" "
9	"	"	106 Mc	"	FM	106 Mc	"	C-1D & C-1B	" "
10	"	"	90 Mc	"	FM	90 Mc	"	L-4 & L-1	" "
11	Repeat steps 7 to 10 for proper dial calibration and maximum output								
12	Adjustment of meter: Refer to text.								

* Negative side of meter to connect to center of two 47K resistors.

† Connect a matched pair of 47K resistors in series and across C-25. After this adjustment, remove the pair of 47K resistors.

Resistance Reference Chart • Model K-100

SOCKET PINS

TUBES	1	2	3	4	5	6	7	8	9
V-1, 6BC8	2 Meg+	1.1 Meg	0	.1	.1	2 Meg+	1.1 Meg	0	0
V-2, 6U8	2 Meg+	1 Meg	2 Meg+	.05	0	2 Meg+	0	1.9	4.7K
V-3, 6BA6	2.5 Meg	0	0	.05	2 Meg+	2 Meg+	100	—	—
V-4, 6AU6	200K	0	.05	0	2 Meg+	2 Meg+	68	—	—
V-5, 6AU6	6.8K	0	.05	0	2 Meg+	2 Meg+	68	—	—
V-6, 6BA6	2 Meg	0	.05	0	2 Meg+	2 Meg+	68	—	—
V-7, 6BE6	22K	0.5	.05	0	2 Meg+	2 Meg+	2.2 Meg	—	—
V-8, 12AX7	2 Meg+	390K	2.7K	30	18	2 Meg+	1 Meg	1.5K	20
V-9, 12AX7	2 Meg+	220K	1.5K	39	28	2 Meg+	1.25 Meg	47K	35
V-10, EL37	—	0	2 Meg+	2 Meg+	500K	2 Meg+	.05	0	—
V-11, EL37	35K	0	2 Meg+	2 Meg+	500K	2 Meg+	.05	0	—
V-12, 12AX7	2 Meg+	330K	2.7K	15	0	2 Meg+	1 Meg	2.2K	15
V-13, 5V4GA	—	—	2 Meg+	70	—	70	—	0	—
V-14, 6X4	47	2 Meg+	.05	0	—	50	2 Meg+	—	—
V-15, EM35	—	.1	2 Meg+	2 Meg	2 Meg+	2 Meg+	0	0	—

CAUTION: Be certain to disconnect AC line cord when making these measurements.

NOTES: Band Switch in FM position except in AM when measuring V-6 and V-7.
All resistance in ohms unless otherwise specified.

K equals 1,000 ohms.

Meg equals 1 megohm.

Voltage Reference Chart • Model K-100

SOCKET PINS

TUBES	1	2	3	4	5	6	7	8	9
V-1, 6BC8	102	-.8	0	6.3AC	0	112	-.7	0	0
V-2, 6U8	86	-2.2	102	6.3AC	0	102	0	0	-3.5
V-3, 6BA6	-.1	0	0	6.3AC	100	100	1.1	—	—
V-4, 6AU6	0	0	6.3AC	0	102	102	.6	—	—
V-5, 6AU6	0	0	6.3AC	0	102	102	.6	—	—
V-6, 6BA6	-.8	0	6.3AC	0	100	100	1.0	—	—
V-7, 6BE6	-12	0	6.3AC	0	105	105	-.8	—	—
V-8, 12AX7	250	0	2.4	-25	-12.5	215	0	1.75	-18.8
V-9, 12AX7	150	0	1.25	-37.5	-25	300	36	41	-31.3
V-10, EL37	0	0	390	395	-31.5	395	6.3AC	0	—
V-11, EL37	-31.5	0	390	395	-31.5	395	6.3AC	0	—
V-12, 12AX7	80	0	.8	-12.5	0	80	0	.68	-6.25
V-13, 5V4GA	—	403	400	395AC	0	395AC	—	403	—
V-14, 6X4	205AC	112	6.3AC	0	—	205AC	165	—	—
V-15, EM35	—	6.3AC	12	-.15	225	12	0	0	—

NOTES: Line voltage set at 117 Volts, 60 Cycles. Voltage readings may vary 10% under normal operating conditions. Band Switch at FM except in AM for V-6 and V-7.

Measurements taken with respect to chassis.

Readings are DC positive unless otherwise specified.

Parts Description List - Model K-100

Symbol	DESCRIPTION	Part No.
C-1A, C-1L	Capacitor, Variable	C-592-116
C-2	Capacitor, Ceramic: 5 mmfd, NPO; 500 V	CC20CH050F5
C-3	Capacitor, Ceramic: 100 mmfd, 600 V; disc	C-577-121
C-4, C-6	Capacitor, Ceramic: .005 mfd, 600 V; disc	CK62GP502V6
C-5, C-8	Capacitor, Ceramic: 470 mmfd, 600 V	C-520-143
C-7	Capacitor, Ceramic: 33 mmfd, 500 V	CC21GP330M5
C-9, C-11, C-12	Capacitor, Ceramic: .005 mfd, 600 V; disc	CK62GP502V6
C-10	Capacitor, Ceramic: 5 mmfd, NPO; 500 V	CC20CH050F5
C-13	Capacitor, Ceramic: 5 mmfd, N150; 500 V	CC20PH050F5
C-14	Capacitor, Ceramic: 82 mmfd, 600 V; 10%	CC21GP820K5
C-15	Capacitor, Ceramic: 13 mmfd, 10%; N030, 30%; 500V	CC21HG130K5
C-16	Capacitor, Ceramic Trimmer: 1-6 mmfd	C-520-159
C-17, C-20, C-21		
C-22	Capacitor, Ceramic: .005 mfd, 600 V; disc	CK62GP502V6
C-18, C-19	Capacitor, Ceramic: 100 mmfd, 500 V	CC21GP101M5
C-23, C-24, C-26	Capacitor, Ceramic: 300 mmfd, 10%; 500 V	CC21GP301K5
C-25	Capacitor, Electrolytic: 10 mfd, 50 V	C-551-146
C-27	Capacitor, Ceramic: 1000 mmfd, 10%; 500 V	CC26GP102K5
C-28	Capacitor: 2.2 mmfd, 500 V	C-3039
C-29	Capacitor, Ceramic: 100 mmfd, 600 V; disc	C-577-121
C-30	Capacitor: .047 mfd, 200 V	C68P473M2
C-31	Capacitor, Ceramic: 10 mmfd, NPO	CC20CH100G5
C-32	Capacitor: 2.2 mmfd, 500 V	C-3039
C-33, C-36, C-37	Capacitor, Ceramic: .02 mfd, disc	C-556-122
C-34	Capacitor, Ceramic: 100 mmfd, 600 V; disc	O-577-121
C-35	Capacitor, Ceramic: 220 mmfd, 500 V	CC21GP221M5
C-38, C-40	Capacitor: .047 mfd, 200 V	C68P473M2
C-39	Capacitor: .0047 mfd, 10%; 200 V	C68P472K2
C-41	Capacitor, Ceramic: 220 mmfd, 10%; 500 V	CC21GP221K5
C-42	Capacitor, Ceramic: 120 mmfd, 10%; 500 V	CC21GP121K5
C-43	Capacitor, Ceramic: 420 mmfd, 10%; 500 V	CC21GP421K5
C-44	Capacitor, Ceramic: 720 mmfd, 10%; 500 V	CC21GP721K5
C-45	Capacitor: .0022 mfd, 10%; 200 V	C68P222K2
C-46	Capacitor: .0033 mfd, 10%; 200 V	C68P332K2
C-47	Capacitor: .02 mfd, 20%; 200 V	C68P203M2
C-48	Capacitor, Electrolytic: 25 mfd, 6 V	C-556-137
C-49, C-54	Capacitor: .1 mfd, 20%; 400 V	C68P104M4
C-50	Capacitor, Ceramic: 220 mmfd, 10%; 500 V	CC21GP221K5
C-51	Capacitor, Ceramic: 120 mmfd, 10%; 500 V	CC21GP121K5
C-52, C-53	Capacitor: .0047 mfd, 10%; 200 V	C68P472K2
C-55	Capacitor, Electrolytic: 25 mfd, 6 V	C-556-137
C-56	Capacitor, Ceramic: .02 mfd, disc	C-556-122
C-57, C-58	Capacitor: .047 mfd, 400 V	C68P473M4
C-59	Capacitor: .22 mmfd; 200 V	C68P224V2
C-60	Capacitor, Electrolytic: 40 mfd, 250 V	C-592-151
C-61A & B	Capacitor, Electrolytic: 40 x 40, mfd, 500 V	C-592-146
C-62A, B, C	Capacitor, Electrolytic: 40 x 30 x 40 mfd, 450 V, 350 V, 250 V	C-592-147
C-63	Capacitor: 2.2 mmfd, 500 V	C-3039
C-64	Capacitor, Electrolytic: 100 mfd, 50 V	C-592-150
C-65, C-66, C-67		
C-69, C-70	Capacitor, Ceramic: .005 mfd, 600 V; disc	CK62GP502V6
C-68	Capacitor: .01 mfd, 600 V	C-2747
C-71	Capacitor, Ceramic: 10 mmfd, N1400; 500 V	CC20VK100G5
C-72	Capacitor, Ceramic: 47 mmfd, 500 V	CC21GP470M5
C-73	Capacitor, Ceramic: 120 mmfd, 10%; 500 V	CC21GP121K5
C-74	Capacitor, Ceramic: 82 mmfd, 10%; 500 V	CC21GP820K5
C-75	Capacitor: .047 mfd, 200 V	C68P473M2
C-76	Capacitor, Ceramic: 100 mmfd, 600 V; disc	C-577-121
C-77	Capacitor, Electrolytic: 40 mfd, 250 V	C-592-151
F-1	Fuse, 3 amp	F-3319
I-1 - I-6	Lamp, Channel Indicator	I-588-120
I-7, I-8	Lamp, 47	I-50009-1
J-1, J-2, J-4		
J-5	Jack	J-50048
J-3, J-7	Jack	J-3143
J-6	Receptacle, AC	J-546-129
L-1	Coil, FM Antenna	L-592-135
L-2	Coil, Neutralization	L-520-178
L-3, L-5	Choke	L-3352
L-4	Coil, FM, RF	L-592-137
L-6	Coil, FM Oscillator	L-592-136
L-7	Loop, AM	L-621-127
L-8	Coil, RF AM	L-556-125
L-9	Coil, AM Oscillator	L-550-122
L-10, L-11, L-12	Choke, Filament	L-520-156
L-13	Choke, Bi-Filar	L-509-140
PC-1	Printed Circuit	PC-552-105
R-1, R-4, R-6	Resistor, Composition: 1 megohm, 10%; 1/2 W	RC20BF105K
R-2	Resistor, Composition: 1500 ohms, 10%; 1/2 W	RC20BF152K
R-3, R-8	Resistor, Composition: 470 ohms, 10%; 1/2 W	RC20BF471K
R-5	Resistor, Composition: 100,000 ohms, 10%; 1/2 W	RC20BF471K
R-7	Resistor, Composition: 33,000 ohms, 10%; 1/2 W	RC20BF333K
R-9	Resistor, Composition: 2700 ohms, 10%; 1/2 W	RC20BF272K
R-10	Resistor, Composition: 4700 ohms, 10%; 1/2 W	RC20BF472K
R-11	Resistor, Composition: 100 ohms, 10%; 1/2 W	RC20BF101K

Parts Description List - Model K-100

Symbol	DESCRIPTION	Part No.
R-12	Resistor, Composition: 330,000 ohms, 10% ; 1/2 W	RC20BF334K
R-13	Resistor, Composition: 1000 ohms, 10% ; 1/2 W	RC20BF102K
R-14, R-15	Resistor, Composition: 100,000 ohms, 10% ; 1/2 W	RC20BF104K
R-16, R-19	Resistor, Composition: 68 ohms, 10% ; 1/2 W	RC20BF680K
R-17	Resistor, Composition: 330,000 ohms, 10% ; 1/2 W	RC20BF334K
R-18	Resistor, Composition: 1000 ohms, 10% ; 1/2 W	RC20BF102K
R-20	Resistor, Composition: 4.7 megohms, 10% ; 1/2 W	RC20BF475K
R-21	Resistor, Composition: 6800 ohms, 10% ; 1/2 W	RC20BF682K
R-22, R-25	Resistor, Composition: 1000 ohms, 10% ; 1/2 W	RC20BF102K
R-23	Resistor, Composition: 270 ohms, 10% ; 1/2 W	RC20BF271K
R-24	Resistor, Composition: 68,000 ohms, 10% ; 1/2 W	RC20BF683K
R-26	Resistor, Composition: 1500 ohms, 10% ; 1/2 W	RC20BF152K
R-27	Resistor, Composition: 15,000 ohms, 10% ; 1/2 W	RC20BF153K
R-28	Resistor, Composition: 1500 ohms, 10% ; 1/2 W	RC20BF152K
R-29	Resistor, Composition: 100,000 ohms, 10% ; 1/2 W	RC20BF104K
R-30	Resistor, Composition: 330,000 ohms, 10% ; 1/2 W	RC20BF334K
R-31, R-34	Resistor, Composition: 1 megohm, 10% ; 1/2 W	RC20BF105K
R-32	Resistor, Composition: 68 ohms, 10% ; 1/2 W	RC20BF680K
R-33, R-37	Resistor, Composition: 1000 ohms, 10% ; 1/2 W	RC20BF102K
R-35	Resistor, Composition: 22,000 ohms, 10% ; 1/2 W	RC20BF223K
R-36	Resistor, Composition: 470,000 ohms, 10% ; 1/2 W	RC20BF474K
R-38	Resistor, Composition: 1.8 megohms, 10% ; 1/2 W	RC20BF185K
R-39	Resistor, Composition: 47,000 ohms, 10% ; 1/2 W	RC20BF473K
R-40	Resistor, Composition: 330,000 ohms, 10% ; 1/2 W	RC20BF334K
R-41	Resistor, Composition: 2700 ohms, 10% ; 1/2 W	RC20BF272K
R-43, R-42	Resistor, Composition: 220,000 ohms, 10% ; 1/2 W	RC20BF224K
R-44	Resistor, Composition: 1 megohm, 10% ; 1/2 W	RC20BF105K
R-45	Resistor, Composition: 220 ohms, 10% ; 1/2 W	RC20BF222K
R-46	Resistor, Composition: 120,000 ohms, 10% ; 1/2 W	RC20BF124K
R-47	Resistor, Composition: 3.3 megohms, 10% ; 1/2 W	RC20BF335K
R-48	Resistor, Composition: 2.2 megohms, 10% ; 1/2 W	RC20BF225K
R-49	Resistor, Composition: 1 megohm, 10% ; 1/2 W	RC20BF105K
R-50	Resistor, Composition: 220,000 ohms, 10% ; 1/2 W	RC20BF224K
R-51	Resistor, Composition: 3.3 megohms, 10% ; 1/2 W	RC20BF335K
R-52	Resistor, Composition: 1500 ohms, 10% ; 1/2 W	RC20BF152K
R-53	Resistor, Composition: 100,000 ohms, 10% ; 1/2 W	RC20BF104K
R-54	Potentiometer with switch	R-592-178
R-55, R-56, R-58	Resistor, Composition: 47,000 ohms, 10% ; 1/2 W	RC20BF473K
R-59	Resistor, Composition: 68,000 ohms, 10% ; 1/2 W	RC20BF683K
R-57, R-60	Potentiometer, dual tone control	R-592-179
R-61A & B	Resistor, Composition: 2700 ohms, 10% ; 1/2 W	RC20BF272K
R-62	Resistor, Composition: 100,000 ohms, 10% ; 1/2 W	RC20BF104K
R-63	Resistor, Composition: 47,000 ohms, 10% ; 1/2 W	RC20BF473K
R-64	Resistor, Composition: 220,000 ohms, 10% ; 1/2 W	RC20BF224K
R-65	Resistor, Composition: 470,000 ohms, 10% ; 1/2 W	RC20BF474K
R-66, R-67	Resistor, Composition: 1.2 megohms, 10% ; 1/2 W	RC20BF125K
R-68	Resistor, Composition: 1000 ohms, 10% ; 1/2 W	RC20BF102K
R-69	Resistor, Composition: 680 ohms, 10% ; 1/2 W	RC20BF681K
R-70	Resistor, Composition: 2700 ohms, 10% ; 1/2 W	RC20BF272K
R-71	Resistor, Composition: 47,000 ohms, 10% ; 1/2 W	RC20BF473K
R-72	Resistor, Composition: 33,000 ohms, 10% ; 1/2 W	RC20BF333K
R-73	Resistor, Composition: 6800 ohms, 10% ; 1/2 W	RC20BF682K
R-74, R-78	Resistor, Composition: 68 ohms, 10% ; 1/2 W	RC20BF680K
R-75, R-76	Resistor, Composition: 330,000 ohms, 10% ; 1/2 W	RC20BF334K
R-77	Resistor, Wirewound: 100 ohms, 10% ; 1/2 W	R-592-185
R-79	Resistor, Wirewound: 50 ohms, 10% ; 7 W	R-592-168
R-80	Resistor, Wirewound: 400 ohms, 5% ; 5 W	R-621-130
R-81	Resistor, Composition: 33,000 ohms, 10% ; 1/2 W	RC20BF333K
R-82, R-85	Resistor, Composition: 270 ohms, 10% ; 2 W	RC40BF271K
R-83	Resistor, Composition: 10 ohms, 10% ; 1/2 W	RC20BF100K
R-84	Resistor, Composition: 1 megohm, 10% ; 1/2 W	RC20BF105K
R-86	Resistor, Composition: 1.8 megohms, 10% ; 1/2 W	RC20BF185K
R-87	Resistor, Composition: 270 ohms, 10% ; 2 W	RC40BF271K
R-88	Switch, Channel Selector	S-592-184
S-1	Switch, Loudness	(part of) R-592-178
S-2	Switch, Power	S-592-149
S-3	Transformer, Power	T-592-125-2
T-1	Transformer, Output	T-563-117
T-2	Transformer, FM, I.F.	ZZ-2987
Z-1	Transformer, FM, I.F.	ZZ-509-130
Z-2, Z-3	FM Ratio Detector	ZZ-592-170
Z-4	Transformer, AM, I.F.	ZZ-2985
Z-5	Transformer, AM, I.F.	ZZ-2984
Z-6		

MISCELLANEOUS

Socket Indicator Light	X-588-123
Dial Glass	N-621-121
Knobs: Rear Dual	E-50049-4
Forward Dual	E-50049-2
Power, ON OFF	E-50049-3
Tuning	E-50049-1
Channel Selector	E-50049-9
Presence and Brilliance	E-50049-8
Presence and Brilliance L Pad	M-211

DIAL STRINGING INSTRUCTIONS

DIAL CORD REPLACEMENT INSTRUCTIONS

1. Remove chassis from cabinet.
2. Remove defective cord and dial pointer.
3. Restring new cord as shown in illustration.
4. Mount dial pointer, and with variable capacitor fully in counterclockwise position, center pointer over index mark at low-frequency end of dial.
5. Secure dial pointer in place by applying household cement.

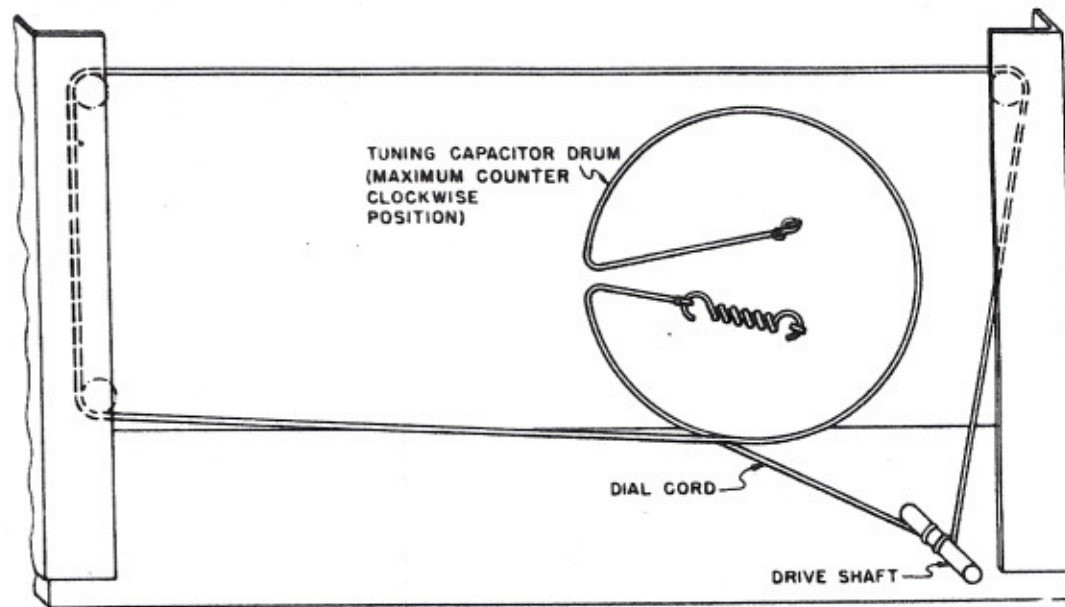

NOTES

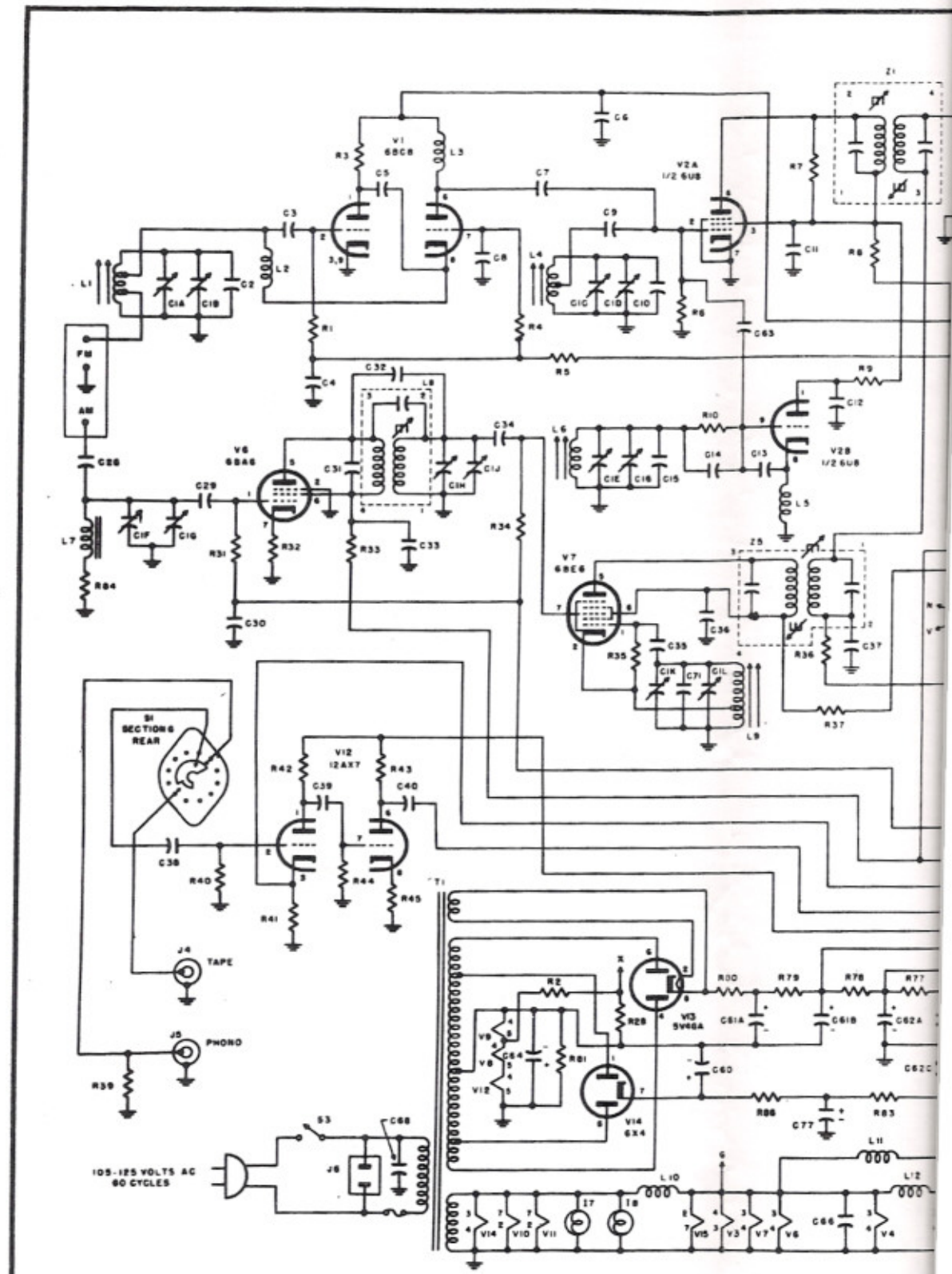

THE

SC

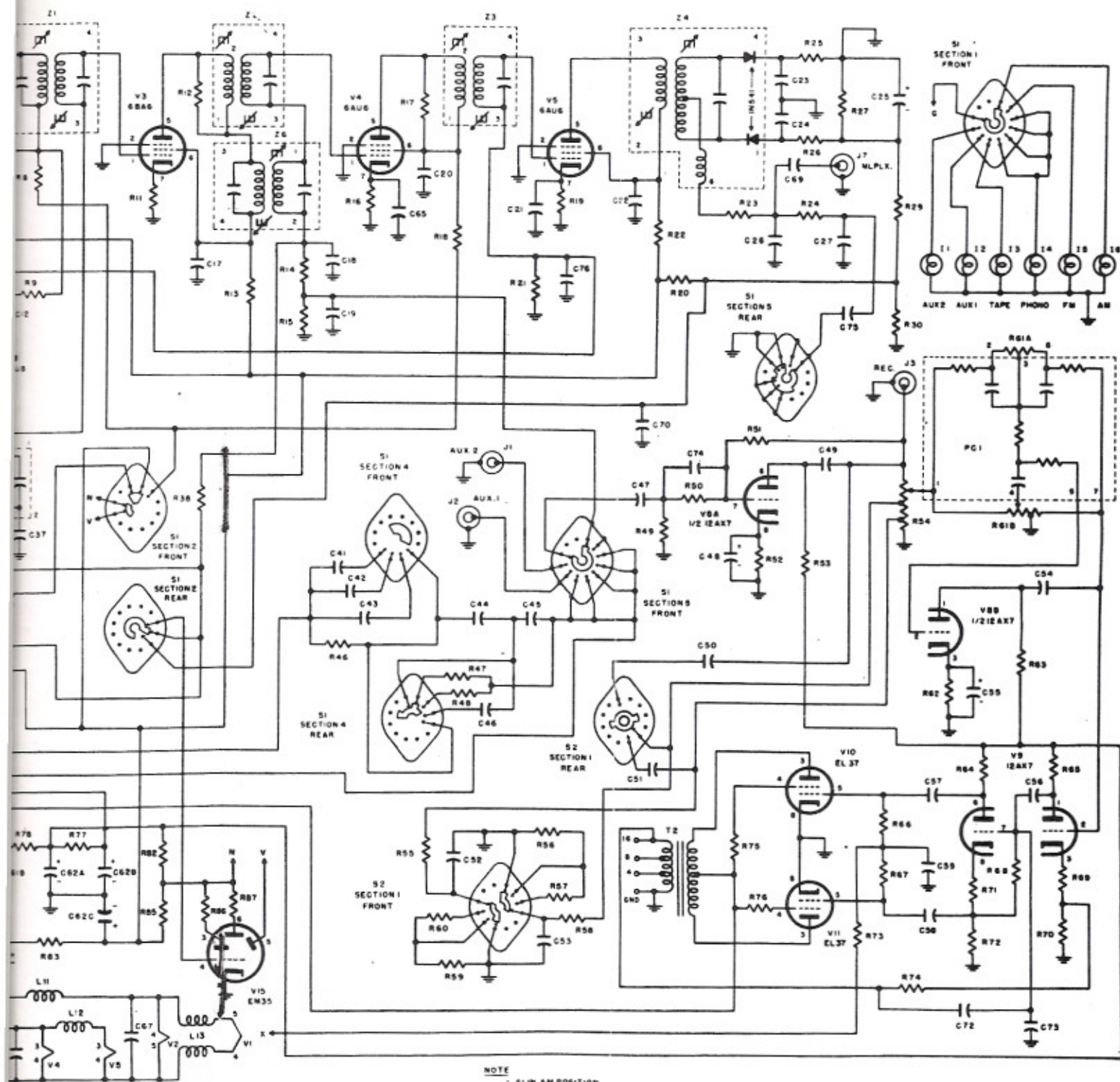

NOTE
 1. S1 IN AM POSITION
 2. S2 LOUDNESS IN OFF POSITION

THE FISHER

MODEL K-100

SCHEMATIC DIAGRAM



FISHER RADIO CORPORATION • NEW YORK

NLN1681-103

© COPYRIGHT 1989 FISHER RADIO CORPORATION

PRINTED IN U.S.A.

25P49