



FISHER

DAC-2415

(XE)

Compact Disc Changer

40 0915
SM580534
SERVICE MANUAL
0708880 23 MENVER

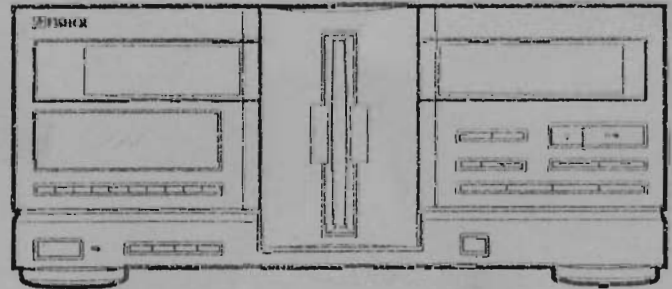

1

PRODUCT CODE No.
137 073 01

CONTENTS

SPECIFICATIONS	1	PARTS LIST	16
LASER BEAM SAFETY PRECAUTIONS .	1	CONNECTION	26
BEFORE USE OR TRANSPORTATION .	1	SCHEMATIC DIAGRAM	28
WHAT TO DO IF	2	WIRING DIAGRAM	30
REMOVAL AND INSTALLATION	2	IC BLOCK DIAGRAM &	
CD CHANGER MOVING TEST	9	DESCRIPTION	42
CD PLAYER ADJUSTMENTS	13	IC VOLTAGES	48
EXPLODED VIEW	15		

REFERENCE No. SM580534

SPECIFICATIONS

Type	24 Disc Bi-Directional, Radial Transport
Channels	2-channel stereo
Sampling frequency	44.1kHz
Digital filter	8× Oversampling
D / A conversion	Dual, 1-Bit
Pick-up	Optical 3-beam semiconductor laser
Frequency response	20 Hz ~ 20 kHz
Total harmonic distortion ..	0.03% (1 kHz)
Signal-to-noise ratio	100 dB
Wow and Flutter	Below measurable limits

Power requirements	AC 230 V , 50 Hz
Power consumption	15 Watts
Dimensions (W×H×D)	Approx. 420x184x402 mm
Weight	Approx. 7 kg

RDAC-2415 WIRELESS REMOTE CONTROL

Power requirements	3V DC - Two "AA" batteries
Dimensions (W×H×D)	Approx. 50x173x18 mm
Weight	Approx. 65 g (without batteries)

Specifications subject to change without notice.

LASER BEAM SAFETY PRECAUTIONS

- Pick-up that emits a laser beam is used in this CD player.

CAUTION :
USE OF CONTROLS OR ADJUSTMENTS
OR PERFORMANCE OF PROCEDURES
OTHER THAN THOSE SPECIFIED
HEREIN MAY RESULT IN HAZARDOUS
RADIATION EXPOSURE

LASER OUTPUT 0.6 mW Max. (CW)
WAVELENGTH 790 nm

CLASS 1 LASER PRODUCT
LUOKAN 1 LASERLAITE
KLASS 1 LASERAPPARAT

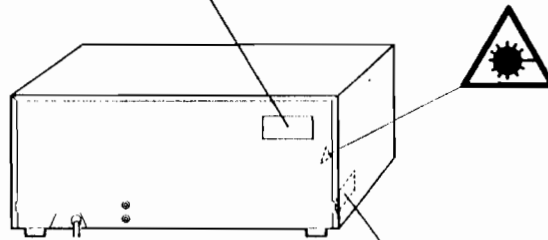

CAUTION - INVISIBLE LASER RADIATION WHEN OPEN AND INTERLOCKS DEFEATED. AVOID EXPOSURE TO BEAM.
ADVARSEL - USYNLIG LASER STRÅLING VED ÅBNING, NÅR SIKKERHEDSAFBRYDERE ER UDE AF FUNKTION, UNDGÅ UDSÆTTELSE FOR STRÅLING.
VARNING - OSYNLIG LASER STRÅLING NÅR DENNA DEL ÄR ÖPPNAD OCH SPÄRR ÄR URKOPPLAD. STRÅLEN ÄR FARLIG.
VORSICHT - UNSICHTBARE LASERSTRALUNG TRITT AUS, WENN DECKEL GEÖFFNET UND WENN SICHERHEITSVERRIEGELUNG ÜBERBRÜCKT IST. NICHT, DEM STRAHL AUSSETZEN.
VARO - AVATTAESSA JA SUOJALUKITUS OHITETTAESSA OLET ALTIINA NÄKYMÄTTÖMÄLLE LASERSÄTEILYLLE. ÄLÄ KATSO SÄTEESEEN.

BEFORE USE OR TRANSPORTATION

Before use

Remove the shipping screw and the brass sleeve from the bottom of the DAC-2415 before use. Please refer to the illustration. (These parts are used to secure the CD mechanism during shipment and should be retained for future use.)

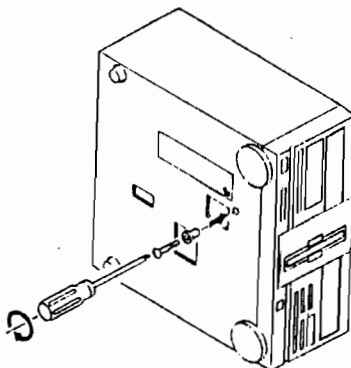

Before transportation

1. Turn on the power and remove all discs from the DAC-2415.
2. Check that "NO DISC" appears on the CD display.
3. Turn off the power and disconnect the power cord.
4. Reinstall the shipping screw and brass sleeve as shown in the illustration.

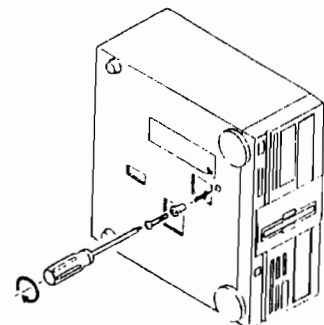

WHAT TO DO IF

If "M-ERROR" scrolls.

1. Press the POWER button to turn the power off.
2. Press the POWER button to turn the power on.

POWER

AC 230 V, 50 Hz

If the operation of the unit or display is not normal, even though the appropriate buttons have been pressed.

1. Disconnect the AC power cord.
2. Wait for at least 20 seconds.
3. Reconnect the power cord.
4. Wait a few seconds until the CD stops.
5. Press the POWER button to turn the power on.
6. Press the desired function button.

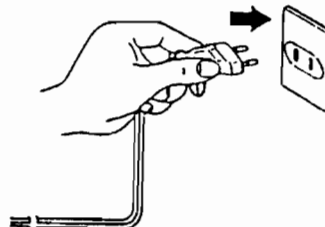
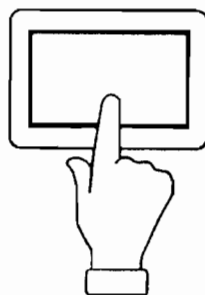

REMOVAL AND INSTALLATION

- Disconnect the power cord's plug from the electrical outlet.
- All wiring should be returned to the original position after work is completed.
- First have ready many the new FIXERS (614 129 2496) for replacement.
- Arrange the lead wires so that they are not near the heat sink.
- **When carrying the unit, be sure to remove any discs which may be inside and turn the power off.**

Then unplug the power cord from the AC outlet after 10 seconds.
Carrying the unit with any discs inside may damage the discs and / or the unit.

- Before beginning the following procedure, prepare a spring hook or tweezers of the type shown at right.

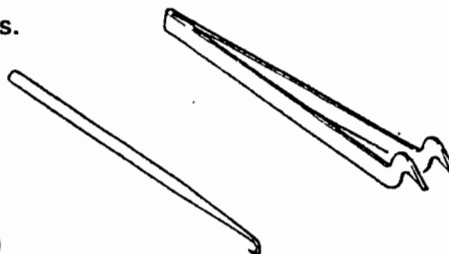

a. FRONT PANEL

- (1) Remove the 6 top cabinet mounting screws.
- (2) Remove the 2 front panel mounting screws. (①)
- (3) Remove the front panel. (②)
- (4) Remove the 6 rotary changer mechanism mounting screws. (③)

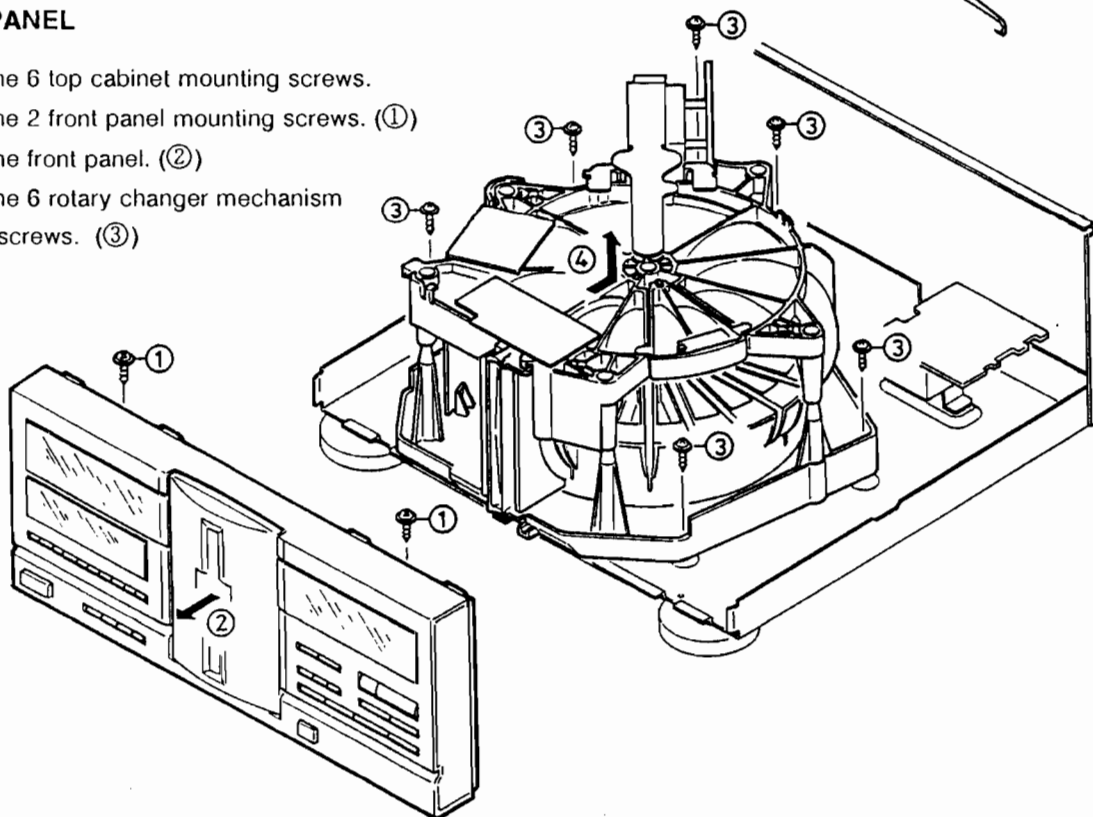

REMOVAL AND INSTALLATION

b. 24-DISC TABLE (TURNTABLE)

- Apply MC-grease "EM-50L" to the places indicated in the diagram.

c. CD MECHANISM

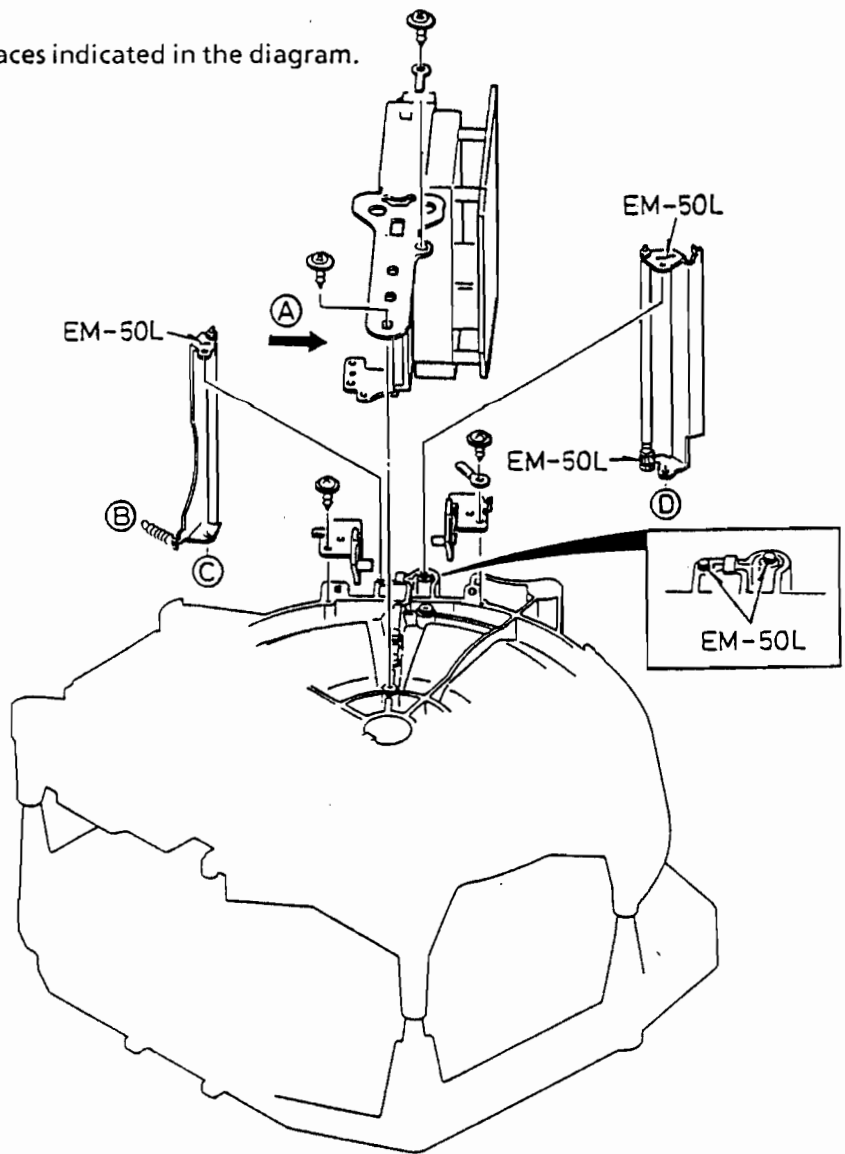
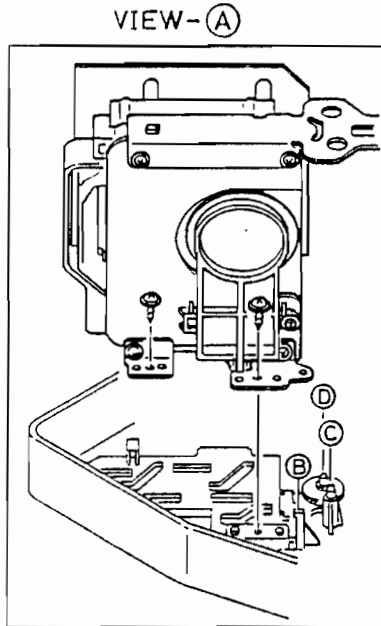

d. INSTALLATION OF TURNTABLE

- (1) Move the disc slide to the position indicated by the arrow. (①)
- (2) Align the hole in the base chassis with the hole in the turntable gear. (②)

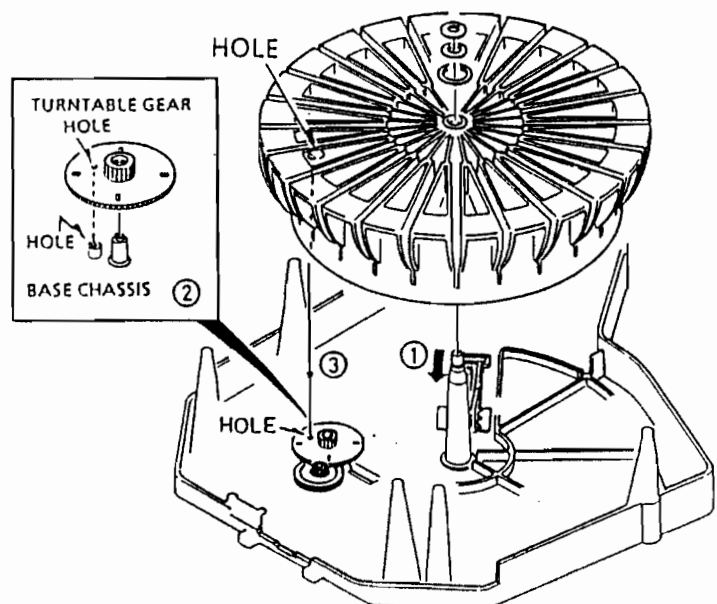

REMOVAL AND INSTALLATION

- (3) Align the turntable so that rib (A) of the base chassis is visible between disc indicators 20 and 21 on the turntable. (3)
- (4) Then insert the turntable.

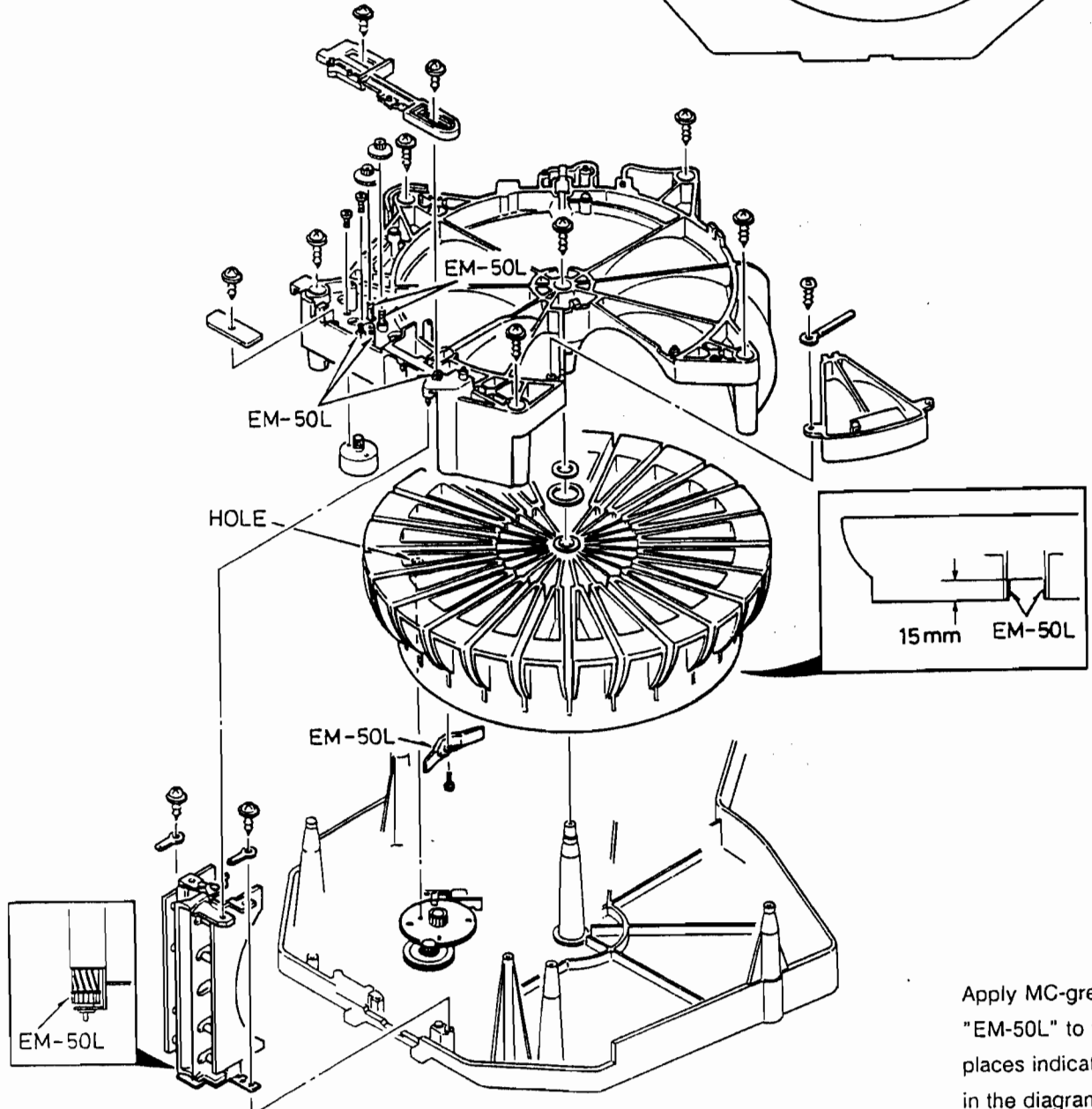
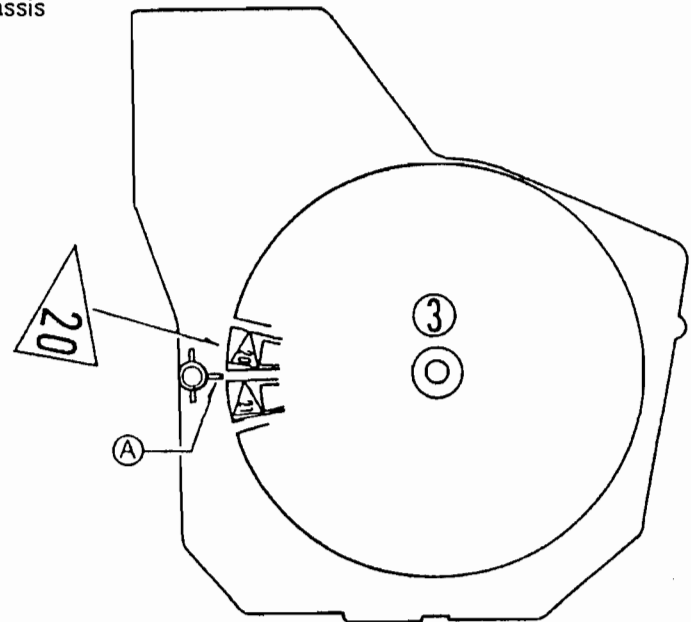

Apply MC-grease "EM-50L" to the places indicated in the diagram.

REMOVAL AND INSTALLATION

e. MOTOR & LOADING GEAR

- Apply MC-grease "EM-50L" to the places indicated in the diagram.

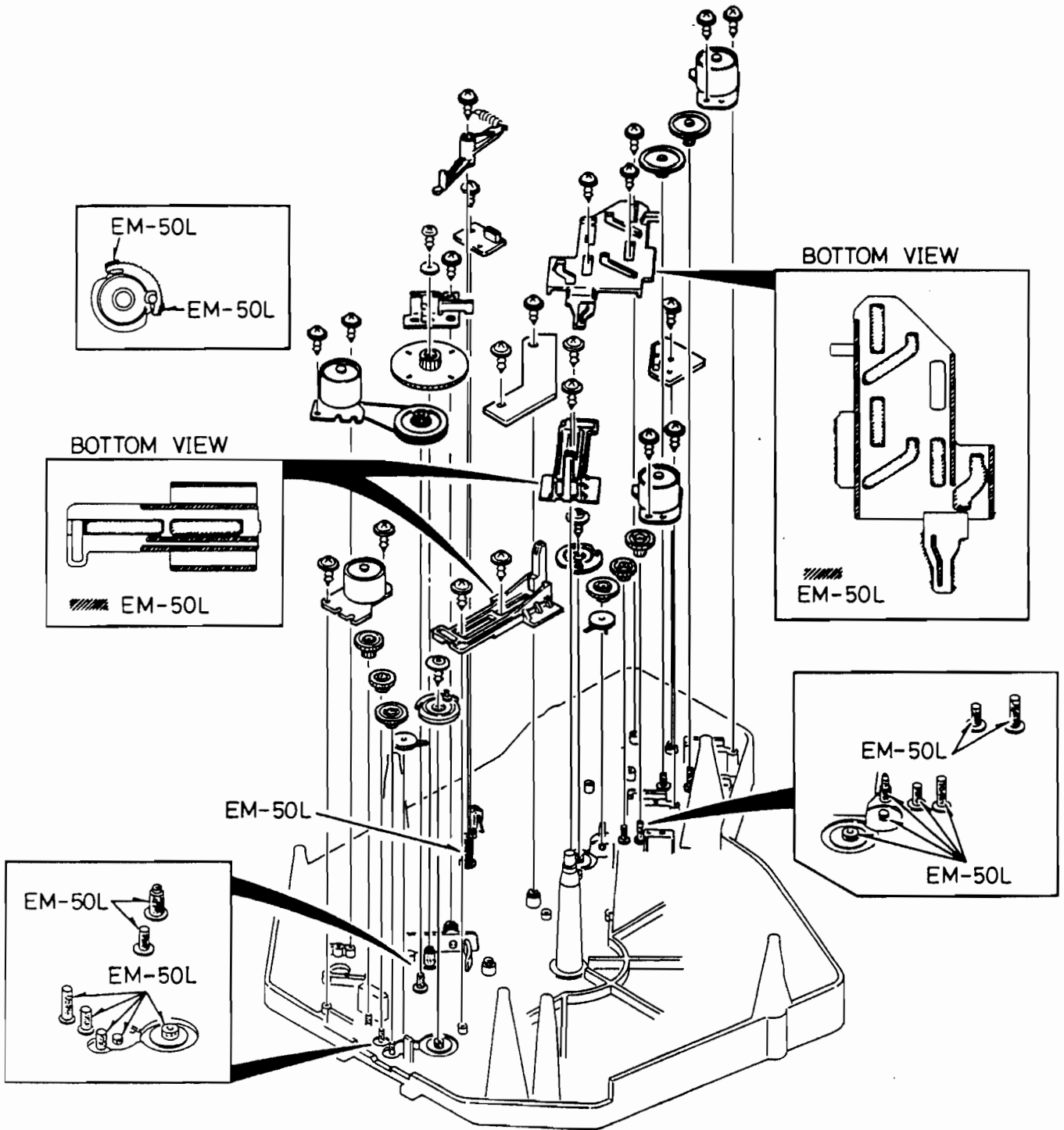

REMOVAL AND INSTALLATION

f. REPLACEMENT OF MOTOR

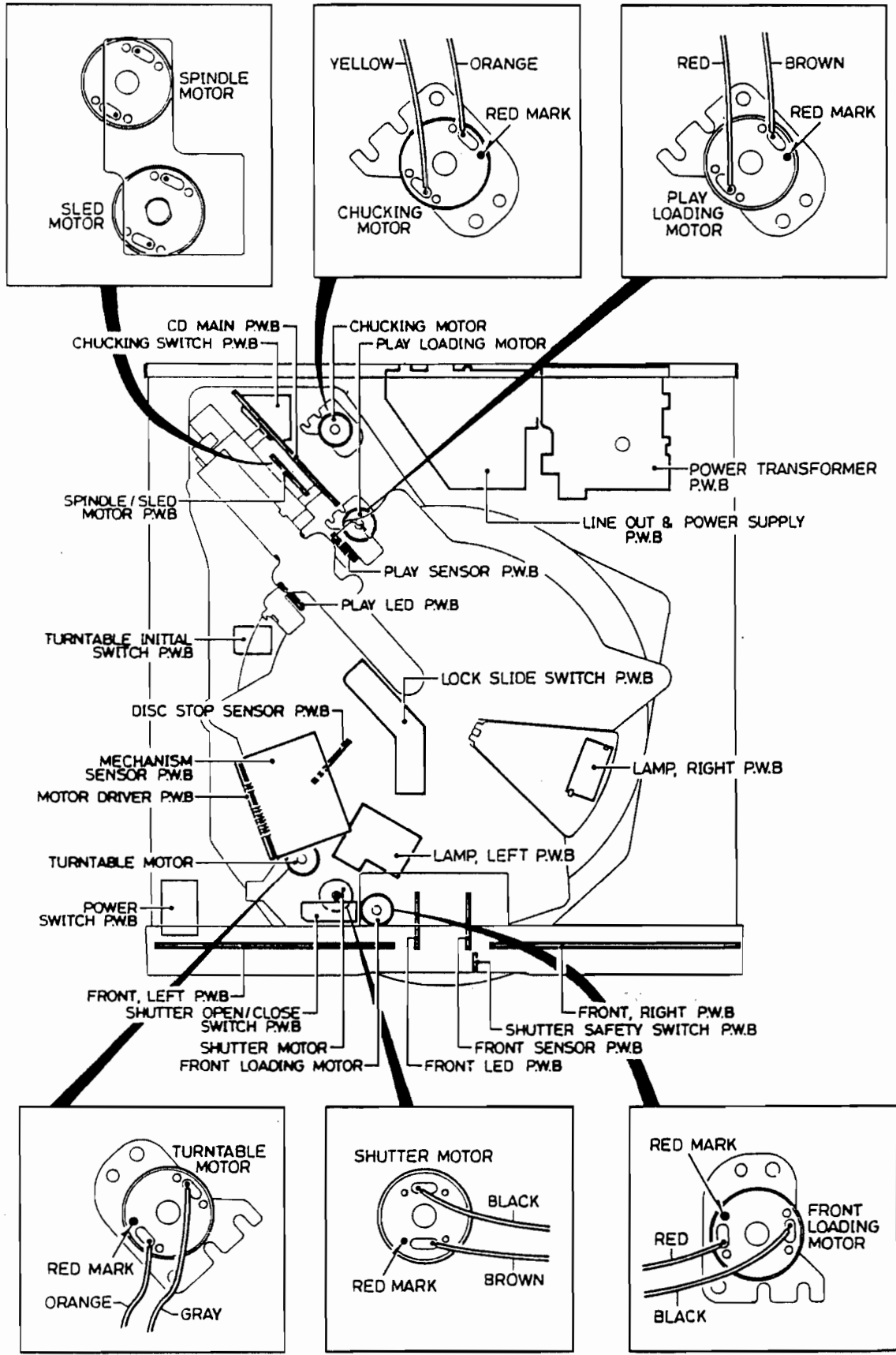

REMOVAL AND INSTALLATION

g. WIRING LAYOUT

- All wiring should be returned to the original position after work is completed.

(a) PLAY LOADING & CHUCKING MOTOR

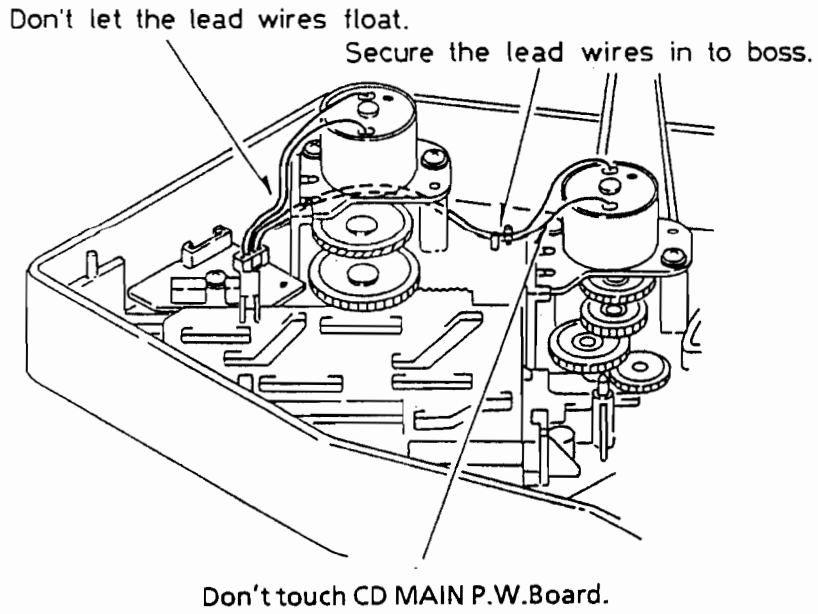

(b) FRONT PANEL

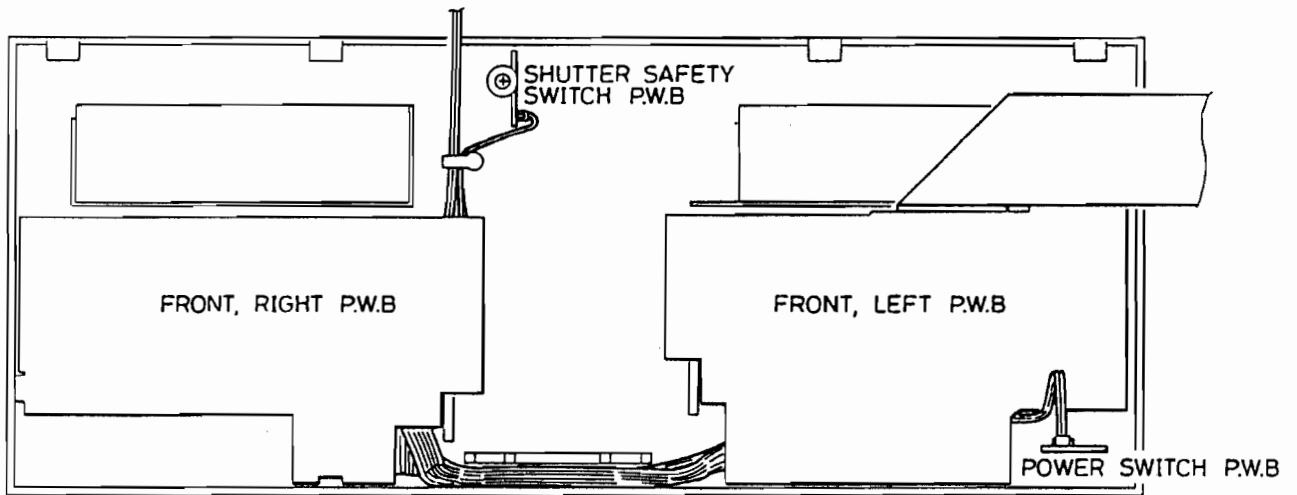

REMOVAL AND INSTALLATION

h. REMOVING CDS FROM 24-DISC TABLE (TURNTABLE)

- If the CDs cannot be removed

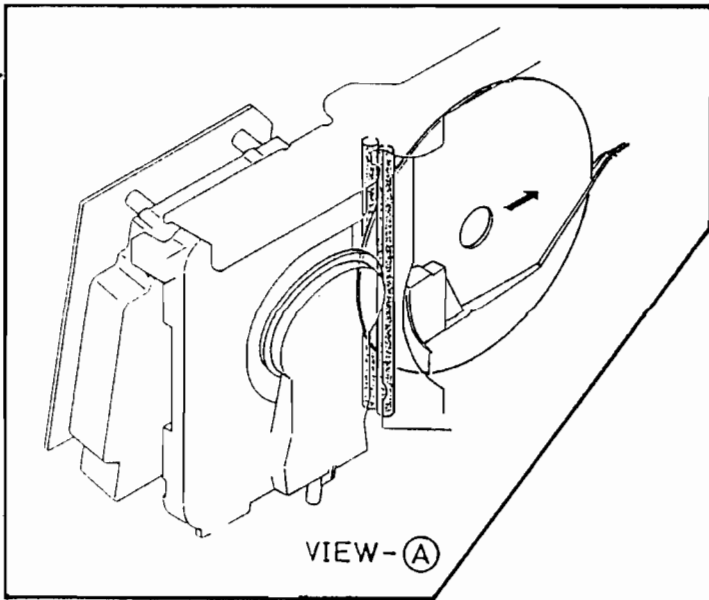

- (1) Check the disc position.
- (2) If the disc is stopped at position (1), use a card or the like to push it in temporarily.
- (3) If the disc is stopped at position (1)', push gently on the disc hole with your fingertip.
- (4) Remove the cover mounting screw. (3)
- (5) If the disc is stopped at position (4), remove it.

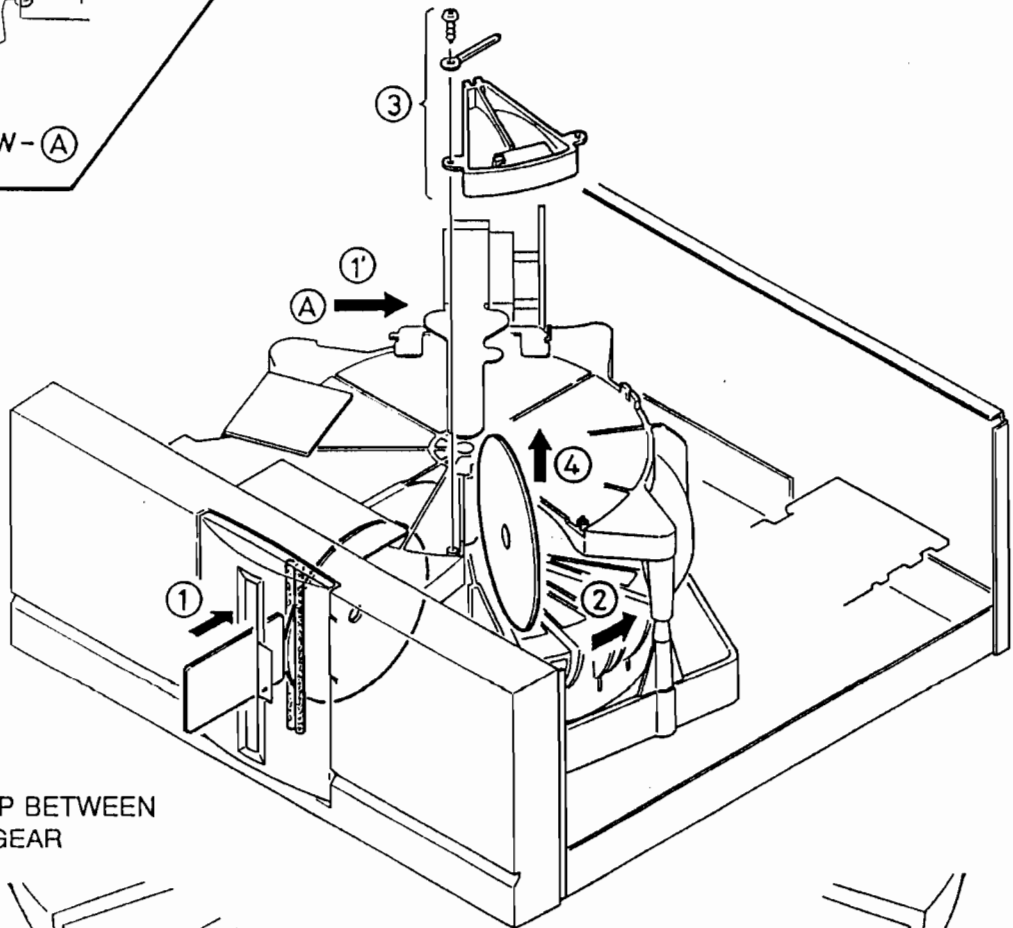

- DIAGRAM OF RELATIONSHIP BETWEEN TURNTABLE MOTOR AND GEAR

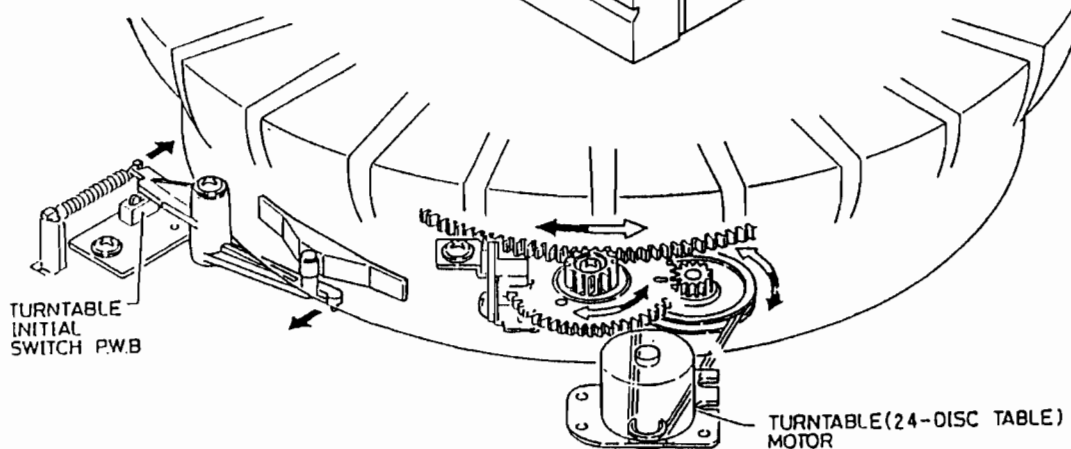

CD CHANGER MOVEMENT TEST

- When servicing CD changers, check the movement according to the following procedures.
Find the malfunctioning location and check the surrounding parts.

a. LOADING MECHANISM

MOVEMENT OF LOADING MECHANISM

No.	DESCRIPTION	NO.	DESCRIPTION
1	MECHANISM INITIAL OPERATION	10	CHUCKING "OFF"
2	24-DISC TABLE TURNS TILL THE No.22 COMES TO FRONT	11	DISC MOVES TO DISC TABLE
3	SHUTTER "OPENS"	12	CHUCKING "ON"
4	LOAD DISC	13	DISC MOVES TO FRONT
5	SHUTTER "CLOSES"	14	SHUTTER "OPENS"
6	DISC TABLE TURNS (BASE MECHANISM)	15	DISC "EJECT"
7	CHUCKING "OFF"	16	TAKE OUT DISC
8	DISC MOVES TO BASE MECHANISM	17	SHUTTER "CLOSES"
9	CHUCKING "ON"		

- (1) Prepare a test disc.
- (2) Turn the POWER switch off.
- (3) Set the CD changer to service mode.

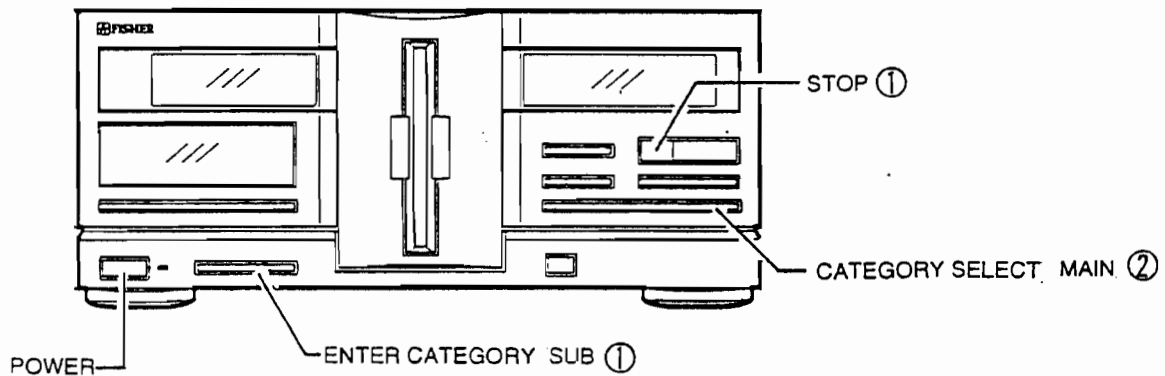

- Simultaneously press the ENTER CATEGORY "SUB" and STOP keys ①, and then press the CATEGORY SELECT "MAIN" key within one second ②.
The CD changer will switch to service mode and the power will automatically turn on.

CD CHANGER MOVEMENT TEST

- (4) Insert the test disc after the shutter opens.
- (5) The test disc enters disc table "22" and is loaded to the base mechanism.
- (6) After the chucking is turned on and off by the base mechanism, the disc table rotates and brings the test disc to a position where it can be removed.
- (7) Remove the test disc.
- (8) The FL display indicates "POWER ON" and then "22 NO DISC".
- (9) If there is any trouble with the mechanism movement, an error message is displayed as shown in the Mechanism Error Indications.
- (10) To cancel service mode, disconnect the power cord's plug from the electrical outlet.

DISC 22	F200000
------------	---------

POWER ON

DISC 22	NO DISC
------------	---------

ERROR INDICATIONS ("MINUTES")

DISPLAY (TIME)	REASON
E1	SHUTTER MOTOR
E2	FRONT LOADING MOTOR
E3	TURN TABLE MOTOR (DISC TABLE MOTOR)
E4	PLAY LOADING MOTOR
E5	CHUCKING MOTOR

ERROR INDICATIONS ("SECOND")

DISPLAY (TIME)	OPERATION
E1	S1809 SHUTTER "OPEN"
E2	S1808 SHUTTER "CLOSE"
E3	S1805 FRONT SLIDE (LOCK SLIDE SWITCH P.W.BOARD)
E4	S1807 POSITION DETECT
E5	S1802 CHUCKING "ON"
E6	S1801 CHUCKING "OFF"
E7	S1804 PLAY SLIDE (LOCK SLIDE SWITCH P.W.BOARD)
E8	SENSOR No.2, 3, 4 and 7
E9	SENSOR No.2 ~ 7
EA	SENSOR No.5 and 6
EB	SENSOR No.1
EC	SENSOR DISC TABLE (TURN TABLE)
ED	S1730 SHUTTER SAFETY

CD CHANGER MOVEMENT TEST

b. BASE MECHANISM

MOVEMENT OF BASE MECHANISM

DISPLAY		DESCRIPTION
TRACK	INDEX	
0	0	FOCUS SEARCH "START"
0	1	FOCUS SEARCH "START"
0	2	WAITING FOR "FOCUSING"
0	3	FOCUSING "START"
0	4	SPINDLE KICKING
0	5	CLV & TRACKING "ON"
0	6	CLV & TRACKING "ON"
0	F	FOCUS SEARCH "END" (SUCCESS / FAILURE)
1	0	SPINDLE BRAKE "START"
1	1	SPINDLE BRAKING
1	2	PICKUP RETURNING
1	F	PICKUP RETURN "COMPLETE"
2	0	FAST FORWARD
2	1	FAST REWIND
3	0	PLAY "START"
3	1	PLAYING
3	2	PLAYING (RECOVER FOR TRACK JUMP)
4	0	TOC READ "START"
4	1	TOC READING
4	F	TOC READ "COMPLETE"
5	*	ACCESS MOVEMENT
6	*	PAUSE MOVEMENT
7	*	FAST ACCESS MOVEMENT

- (1) Prepare a test disc.
- (2) Turn the POWER switch off.
- (3) Set the CD changer to service mode.

- Simultaneously press the ENTER CATEGORY "SUB" and STOP keys ①, and then press the "MEMORY" key within one second ②.

The CD changer will switch to service mode and the power will automatically turn on.

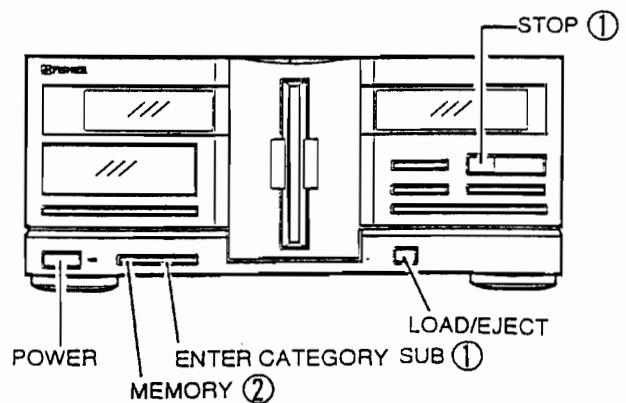

CD CHANGER MOVEMENT TEST

- (4) Press the LOAD / EJECT key and insert the test disc after the shutter opens.
- (5) Press the PLAY / PAUSE key.
- (6) The FL display indicates "22 31", etc.
- (7) If there is any trouble with the mechanism movement, the CD ERROR status will be displayed in the disc calendar.
- (8) To cancel service mode, disconnect the power cord's plug from the electrical outlet.

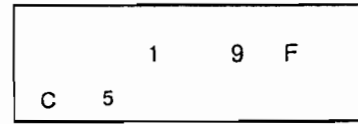
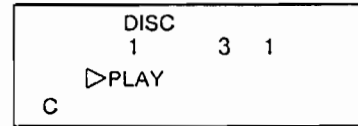

↑ Disc calendar

ERROR INDICATIONS ("DISC CALENDER")

DISPLAY	REASON
	GOOD
1	FOCUSING IS "IMPOSSIBLE"
2	SUB - CODE CANNOT ENTER ON "DISC STARING"
3	TOC CANNOT "READ"
4	FOCUSING WAS LOST WHILE THE SERVO WAS "ON"
5	SUB - CODE CANNOT ENTER WHILE THE SERVO IS "ON"

c. DISC COUNT TEST

- (1) Insert a disc into disc table "No. 1".
- (2) Insert a disc into disc table "No. 12".
- (3) Press the PLAY key.
- (4) Disc "No. 12" is played.
- (5) Press the DISC SKIP "UP" key.
- (6) Confirm that disc "No. 1" is playing.
- (7) Press the LOAD / EJECT key and remove disc "No. 1" after the shutter opens.
- (8) Press DISC SELECT key "12", and then press the PLAY / PAUSE key.
- (9) Press the LOAD / EJECT key and remove disc "No. 12".

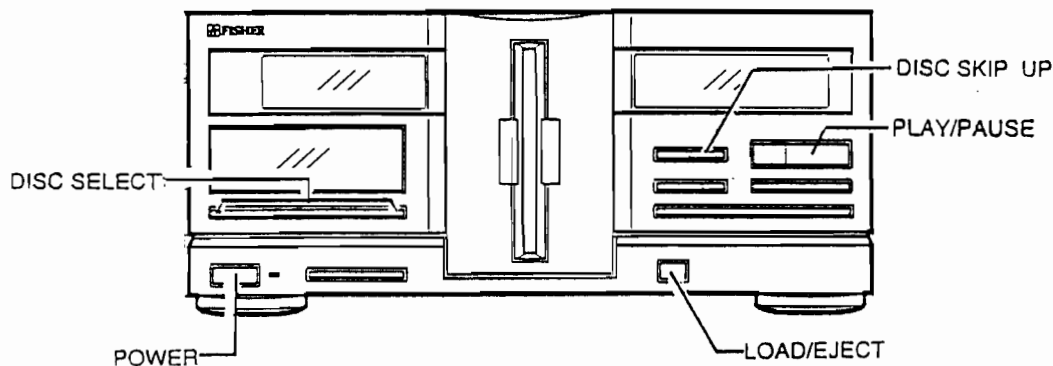

CD PLAYER ADJUSTMENTS

a. REPLACEMENT AND LUBRICATION OF THE PICKUP

- (1) If the pick-up is reconditioned or replaced, be sure to wipe the rails clean and also apply a coating of FLOIL (G-474B) to their entire circumference and entire length.
- (2) The pick-up P.C.Board pattern is "shorted", as shown in the figure , so that the new pick-up will not be susceptible to the effects of static.
- (3) Set the pattern to "open" after the pick-up has been replaced.

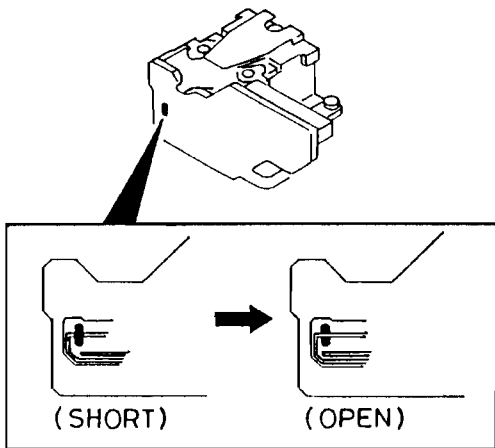
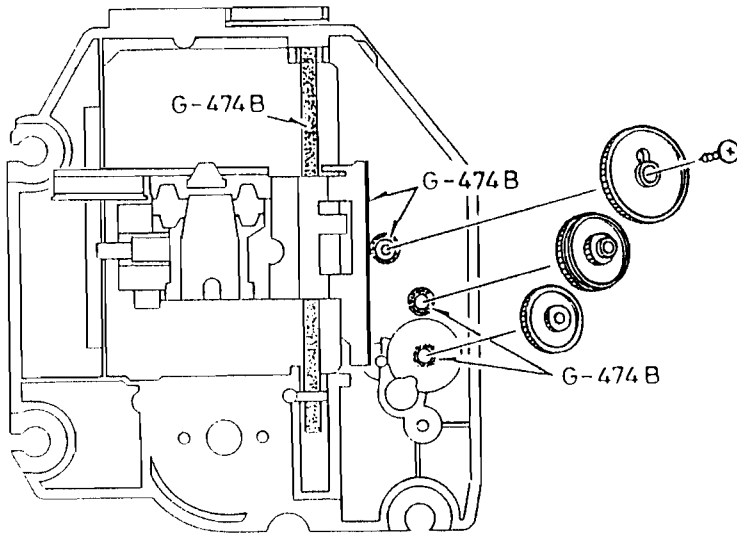
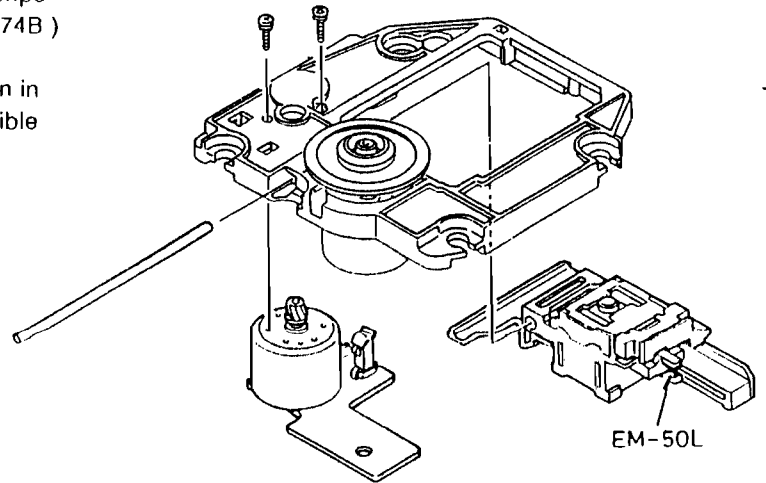

Confirm end catch is completely inserted into chassis.

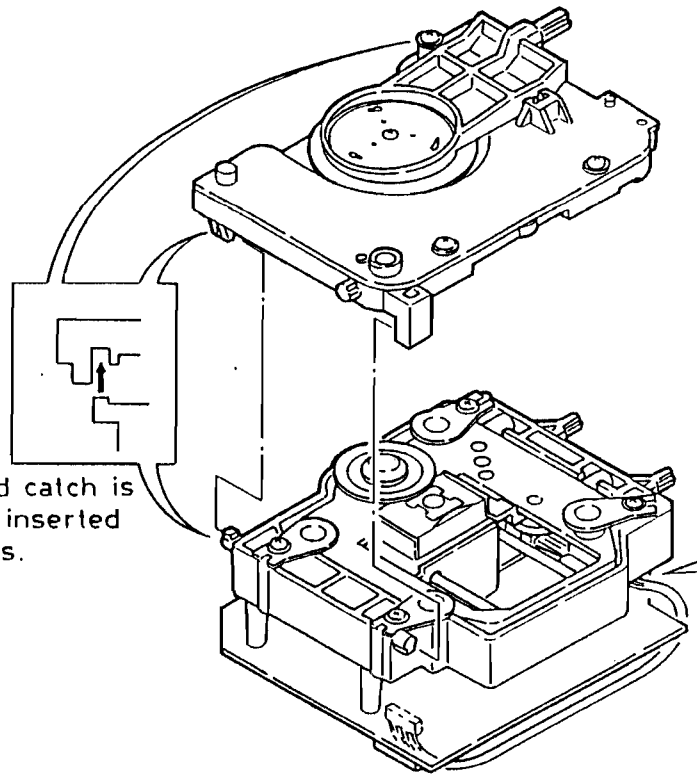

CD PLAYER ADJUSTMENTS

b. PREPARATIONS

(a) Measuring instruments, tools

- (1) Test disc. : YEDS 18 (SONY) or etc.
- (2) Oscilloscope : SS5711 (10 MHz or dual-phenomenon)
or Memoryscope : DSS6521 (Storagescope)
- (3) Resistor, Carbon 2.2 K ohm, 1/4W
- (4) Low Pass Filter (L.P.F.)
- (5) Screwdrivers (non-metallic) for adjustments

c. PARTS LOCATION

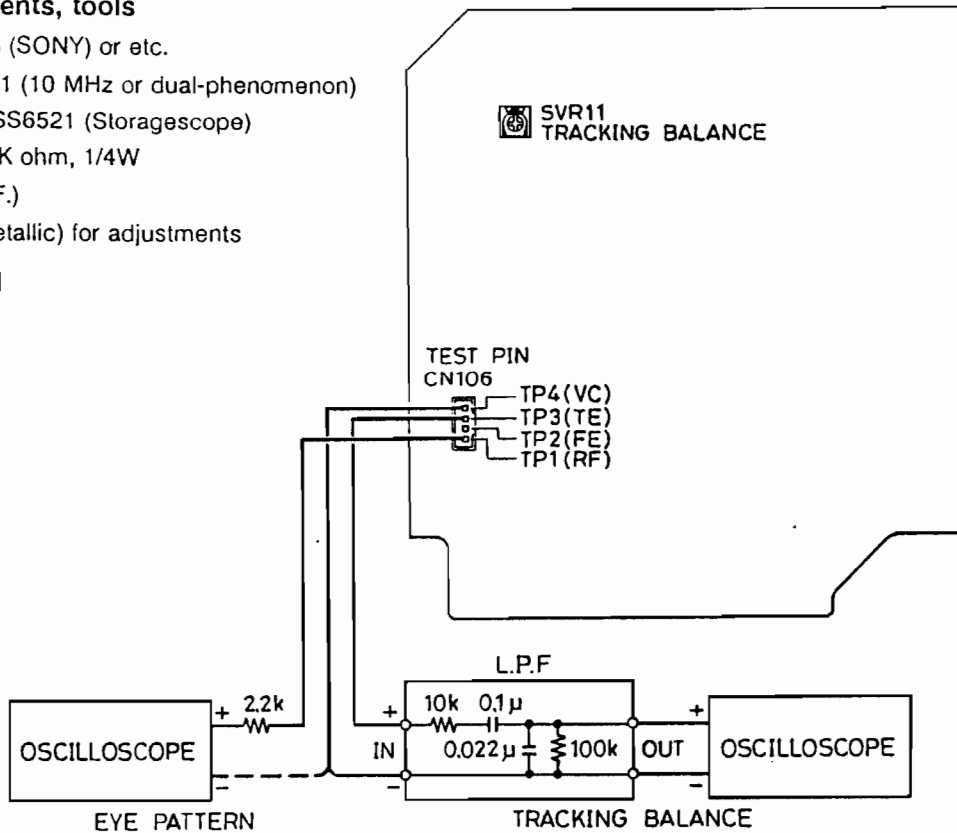

d. TRACKING BALANCE ADJUSTMENT

- (1) Within one second after pressing the **ENTER CATEGORY SUB** and **STOP** switches at the same time, press the **PLAY / PAUSE** switch.
(Service mode : **TRACKING BALANCE**)
- (2) Connect an oscilloscope to TP 3 (TE) and TP 4 (VC).
- (3) Set the test disc.
- (4) **PLAY / PAUSE** switch push ON.
- (5) Adjust **VR101** so that the oscilloscope's waveform is symmetrical, as shown in the illustration.
- (6) Switch OFF the power.

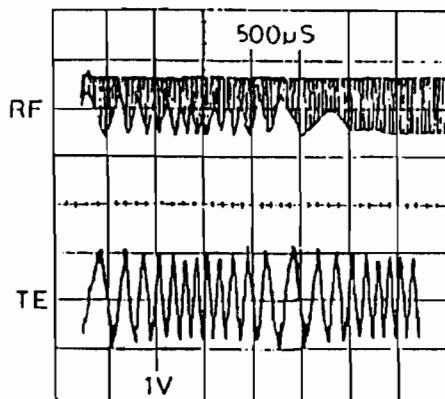

e. CHECKING THE EYE PATTERN

- (1) Switch ON the power.
- (2) Connect an oscilloscope to TP 1 (RF) and TP 4 (VC).
- (3) Load the test disc.
- (4) **PLAY** switch push ON.
- (5) Check to be sure that the " eye " pattern is at the center of waveform and that the diamond shape is clearly defined.
- (6) Press the **STOP** button.
- (7) Switch OFF the power.

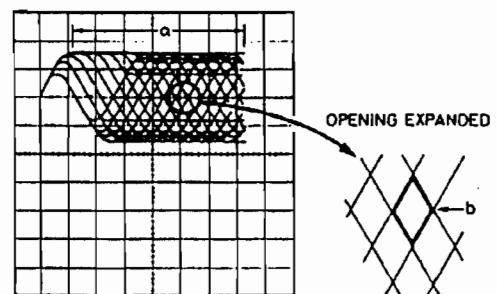

EXPLODED VIEW (CABINET & CHASSIS)

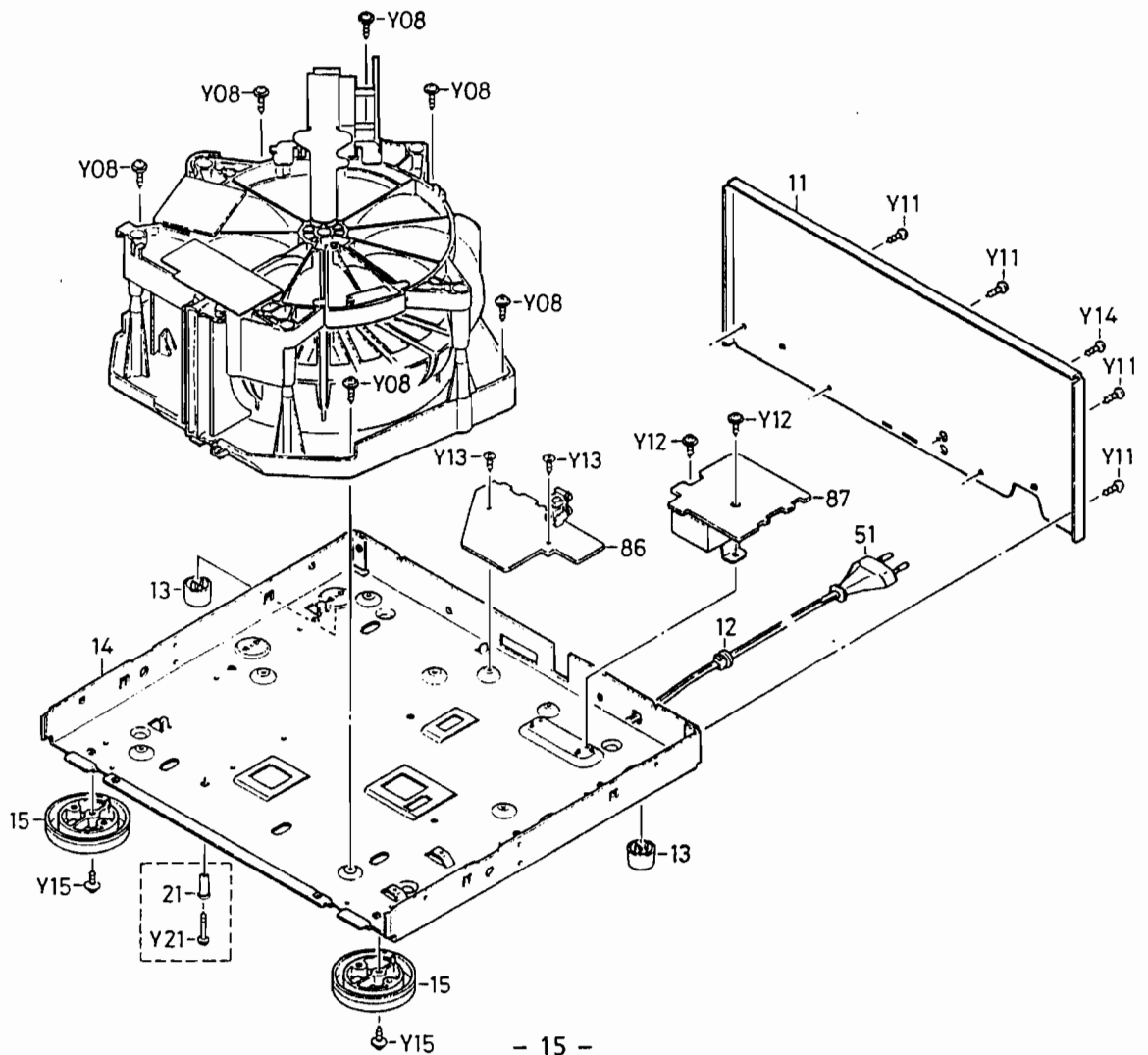
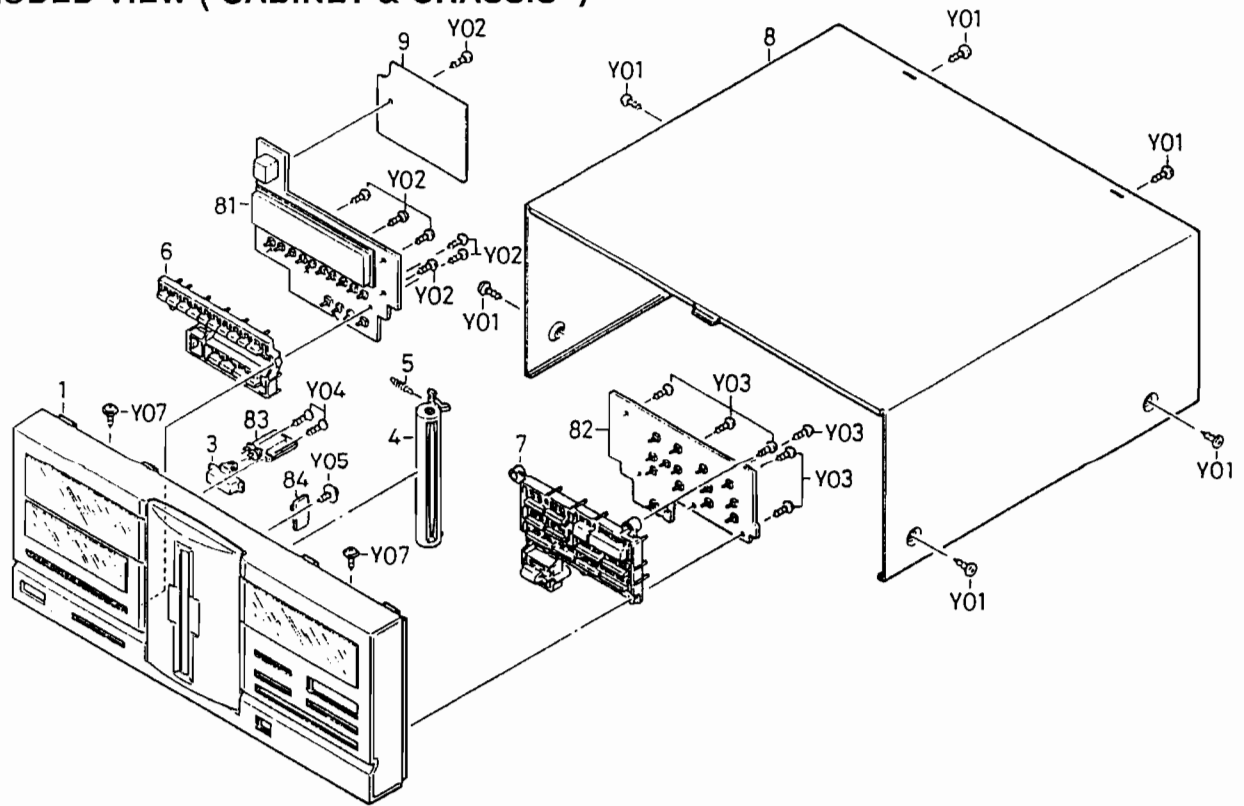

PARTS LIST

PRODUCT SAFETY NOTICE

Each precaution in this manual should be followed during servicing. Components identified with the IEC symbol Δ in the parts list and the schematic diagram designate components in which safety can be of special significance. When replacing a component identified Δ , use only the replacement parts designated, or parts with the same ratings of resistance, wattage or voltage that are designated in the parts list in this manual. Leakage-current or resistance measurements must be made to determine that exposed parts are acceptably insulated from the supply circuit before returning the product to the customer.

CAUTION: Regular type resistors and capacitors are not listed. To know those values, refer to the schematic diagram.

N.S.P : Not available as service parts.

PACKING & ACCESSORIES

Ref. No.	Part No.	Description
	614 272 6068	CARTON CASE, SET
	614 257 5819	PAD, SET, TOP
	614 257 5826	PAD, SET, BOTTOM
	614 257 5802	SHEET, SET, 550X300MM
	614 257 5857	INNER POLY COVER, 600X700MM
	614 272 6150	OWNERS MANUAL
	614 191 3698	LABEL, LASER CAUTION MARK
	614 232 0464	LABEL, SAFETY, CAUTION
	614 231 6832	LABEL, SAFETY, CLASS 1
	614 255 5033	NOTICE
	614 255 5040	LABEL
	614 216 6833	CORD, LINE OUT
	645 008 9480	REMOTE CONTROL, RB-RDAC-2415
	645 006 4654	LID, REMOTE CONTROL

Ref. No.	Part No.	Description
Y13	411 021 6405	SCR S-TPG BIN 3X8MM, LINE OUT & POWER SUPPLY PWB
Y14	411 021 3503	SCR S-TPG BIN 3X10MM, LINE OUT SOCKET
Y15	411 020 9902	SCR S-TPG BRZ+FLG 3X8MM, FOOT STAND
Y21	411 001 1703	SCR S-TPG PAN 3X30MM, SHIPPING SCREW

ELECTRICAL PARTS

Ref. No.	Part No.	Description
51	Δ 614 023 3100	POWER CORD, AC
or	Δ 614 255 2513	POWER CORD, AC
or	Δ 614 233 8971	POWER CORD, AC
or	Δ 614 023 3148	POWER CORD, AC
T1001	Δ 614 257 6984	TRANSFORMER, POWER
61	614 253 5806	ASSY, CONNECTOR-S, 4P, CHUCKING MOTOR & PLAY LOADING MOTOR
62	614 253 8968	ASSY, CONNECTOR-S, 7P
or	614 271 9251	(CN181-CN151)
63	614 253 8913	ASSY, CONNECTOR-S, 2P
or	614 271 9213	(CN159-CN189)
64	614 253 8975	ASSY, CONNECTOR-S, 8P
or	614 271 9268	(CN160-CN188)
65	614 253 5790	ASSY, WIRE, 4P, FRONT LOADING & TURNTABLE MOTOR (CN153)
66	614 253 8913	ASSY, CONNECTOR-S, 2P
or	614 271 9213	(CN186-CN150)
67	614 253 8913	ASSY, CONNECTOR-S, 2P
or	614 271 9213	(CN191-CN158)
68	614 253 8944	ASSY, CONNECTOR-S, 2P
or	614 253 9549	(CN190-CN157)
69	614 253 8951	ASSY, CONNECTOR-S, 6P
or	614 271 9244	(CN183-CN152)
70	614 268 8809	ASSY, WIRE, 2P, SHUTTER MOTOR (CN150)
72	614 253 5288	ASSY, CONNECTOR-S, 4P (CN115-CN105)
73	614 253 5271	ASSY, CONNECTOR-S, 2P (CN116-CN104)
74	614 269 6361	ASSY, WIRE, 6P (CN119-CN135)
75	614 269 6378	ASSY, WIRE, 7P (CN112-CN134)
76	645 010 2776	FLEXIBLE FLAT CABLE, 32P (CN130-CN156)
77	614 249 8682	FLEXIBLE FLAT CABLE, 16P (CN131-CN103)
79	614 253 8937	ASSY, CONNECTOR-S, 3P, SHUTTER OPEN/CLOSE SWITCH
or	614 273 9525	(CN187-CN105)
	614 129 9082	LOG, GROUND

CABINET & CHASSIS

Ref. No.	Part No.	Description
1	614 272 5443	ASSY, PANEL, FRONT
3	614 248 6160	BUTTON, POWER SWITCH
4	614 248 9178	DOOR, SHUTTER
5	614 249 4059	SPRING, TENSION, SHUTTER DOOR
6	614 264 7578	BUTTON, LEFT SIDE, FRONT, DISC SELECT/ENTER CATEGORY
7	614 264 7561	BUTTON, RIGHT SIDE, FRONT, OPERATION
8	614 248 9147	CABINET, TOP
9	614 268 8885	COVER, WINDOW, FRONT, LEFT PWB
11	614 272 5832	PANEL, REAR
12	614 129 1901	FIXER, AC POWER CORD
13	614 252 8969	ASSY, FOOT, BOTTOM, REAR
14	614 248 9154	CABINET, BOTTOM
15	614 268 0827	ASSY STAND, BOTTOM, FRONT
21	614 255 3350	PIPE, SHIPPING
	614 129 4971	FIXER, NYLON, LEAD FIX

FIXING PARTS

Ref. No.	Part No.	Description
Y01	411 021 6603	SCR S-TPG BIN 3X8MM, CABINET
Y02	411 021 3503	SCR S-TPG BIN 3X10MM, FRONT, LEFT PWB
Y03	411 021 3503	SCR S-TPG BIN 3X10MM, FRONT RIGHT
Y04	411 022 2802	SCR S-TPG FLT 3X10MM, POWER SWITCH
Y05	412 032 6408	SPECIAL SCREW, SHUTTER SAFETY SWITCH
Y07	411 020 9902	SCR S-TPG BRZ+FLG 3X8MM, FRONT PANEL
Y08	411 020 9902	SCR S-TPG BRZ+FLG 3X8MM, ROTARY CHANGER MECHANISM
Y11	411 021 6405	SCR S-TPG BIN 3X8MM, REAR CABINET
Y12	411 020 9902	SCR S-TPG BRZ+FLG 3X8MM, POWER TRANSFORMER

PARTS LIST

FRONT, LEFT P.W.BOARD ASSY

Ref. No.	Part No.	Description
81	614 272 5252	ASSY,PWB,FRONT,LEFT
	614 266 6579	HOLDER,FL DISPLAY
C1304	404 060 3009	OS-SOLID 10U M 16V
CN130	614 227 7836	SOCKET,32P
CN131	614 240 8315	SOCKET,16P
CN132	614 035 4959	SOCKET,6P
CN133	614 035 4911	SOCKET,2P
or	614 237 9752	SOCKET,2P
CN134	645 006 0946	PLUG,7P
CN135	645 005 8127	PLUG,6P
CN136	614 035 4911	SOCKET,2P
or	614 237 9752	SOCKET,2P
D1301	407 007 9904	DIODE GMA01
or	407 012 4406	DIODE 1SS133
or	407 012 5809	DIODE 1SS176
D1302	407 007 9904	DIODE GMA01
or	407 012 4406	DIODE 1SS133
or	407 012 5809	DIODE 1SS176
D1306	408 020 9704	LED SLZ-151B-01-AB
D1311	407 007 9904	DIODE GMA01
or	407 012 4406	DIODE 1SS133
or	407 012 5809	DIODE 1SS176
D1312	407 007 9904	DIODE GMA01
or	407 012 4406	DIODE 1SS133
or	407 012 5809	DIODE 1SS176
D1313	407 007 9904	DIODE GMA01
or	407 012 4406	DIODE 1SS133
or	407 012 5809	DIODE 1SS176
D1706	407 007 9904	DIODE GMA01
or	407 012 4406	DIODE 1SS133
or	407 012 5809	DIODE 1SS176
FL171	645 266 7781	FLUORESCENT TUBE
IC111	410 212 7207	IC CXP82432A-107Q
IC112	409 283 6905	IC LE24C04S1
or	410 182 3100	IC ST24C04B1
or	410 177 3702	IC AT24C04-10PC
or	409 351 4109	IC ST24C04CB1
Q1301	405 000 4407	TR DTC124ES
or	405 078 2800	TR BA1F4M
or	405 001 0309	TR RN1203
Q1302	405 001 9302	TR 2SA1020-Y
Q1303	405 011 8609	TR 2SC1740S-S
or	405 011 8500	TR 2SC1740S-R
or	405 015 6403	TR 2SC2785-F
or	405 015 6205	TR 2SC2785-E
or	405 014 5209	TR 2SC2458-GR
X1301	614 215 5561	RESONATOR,CERAMIC
S1701	645 006 2827	SWITCH,PUSH 1P-1T, DISC SELECT,"0"
S1702	645 006 2827	SWITCH,PUSH 1P-1T, DISC SELECT,"9"
S1703	645 006 2827	SWITCH,PUSH 1P-1T, DISC SELECT,"8"
S1704	645 006 2827	SWITCH,PUSH 1P-1T, DISC SELECT,"7"
S1705	645 006 2827	SWITCH,PUSH 1P-1T, DISC SELECT,"6"
S1706	645 006 2827	SWITCH,PUSH 1P-1T, DISC SELECT,"5"
S1707	645 006 2827	SWITCH,PUSH 1P-1T, DISC SELECT,"4"

Ref. No.	Part No.	Description
S1708	645 006 2827	SWITCH,PUSH 1P-1T, DISC SELECT,"3"
S1709	645 006 2827	SWITCH,PUSH 1P-1T, DISC SELECT,"2"
S1710	645 006 2827	SWITCH,PUSH 1P-1T, DISC SELECT,"1"
S1712	645 006 2827	SWITCH,PUSH 1P-1T, ENTER CATEGORY,MAIN
S1713	645 006 2827	SWITCH,PUSH 1P-1T, ENTER CATEGORY,SUB
S1716	645 006 2827	SWITCH,PUSH 1P-1T,MEMORY
S1717	645 006 2827	SWITCH,PUSH 1P-1T,CLEAR
S1750	407 138 4700	PHOTO DIODE SPS-420-1, IR SENSOR

FRONT, RIGHT P.W.BOARD ASSY

Ref. No.	Part No.	Description
82	614 272 5269	ASSY,PWB,FRONT RIGHT
CN138	614 035 4959	SOCKET,6P
CN139	614 035 4911	SOCKET,2P
or	614 237 9752	SOCKET,2P
S1714	645 006 2827	SWITCH,PUSH 1P-1T, DISC SKIP,"UP"
S1715	645 006 2827	SWITCH,PUSH 1P-1T, DISC SKIP,"DOWN"
S1718	645 006 2827	SWITCH,PUSH 1P-1T,LOAD/EJECT
S1719	645 006 2827	SWITCH,PUSH 1P-1T,STOP
S1720	645 006 2827	SWITCH,PUSH 1P-1T,PLAY/PAUSE
S1721	645 006 2827	SWITCH,PUSH 1P-1T,FWD
S1722	645 006 2827	SWITCH,PUSH 1P-1T,BACK
S1723	645 006 2827	SWITCH,PUSH 1P-1T, CATEGORY,MAIN
S1724	645 006 2827	SWITCH,PUSH 1P-1T, CATEGORY,SUB
S1725	645 006 2827	SWITCH,PUSH 1P-1T,REPEAT
S1726	645 006 2827	SWITCH,PUSH 1P-1T,RANDOM
S1727	645 006 2827	SWITCH,PUSH 1P-1T,INTRO
S1728	645 008 2827	SWITCH,PUSH 1P-1T,DISPLAY
S1729	645 006 2827	SWITCH,PUSH 1P-1T,EDIT

POWER SWITCH P.W.BOARD ASSY

Ref. No.	Part No.	Description
83	614 266 4377	ASSY,PWB,POWER SWITCH
CN137	614 035 4911	SOCKET,2P
or	614 237 9752	SOCKET,2P
S1700	614 253 1150	SWITCH,PUSH,POWER

SHUTTER SAFETY SWITCH P.W.BOARD ASSY

Ref. No.	Part No.	Description
84	614 266 1512	ASSY,PWB,SHUTTER SAFETY SWITCH
CN143	614 035 4911	SOCKET,2P
or	614 237 9752	SOCKET,2P
S1730	614 249 1355	SWITCH,LEVER,SHUTTER SAFETY

PARTS LIST

LINE OUT & POWER SUPPLY P.W.BOARD ASSY

Ref. No.	Part No.	Description
86	614 272 5276	ASSY,PWB,LINE OUT & POWER SUPPLY
CN111	645 004 2928	PLUG,6P
CN112	645 006 0861	PLUG,7P
CN115	645 005 8110	PLUG,4P
CN116	645 005 7366	PLUG,2P
CN117	645 008 7028	JACK,RCA-2,LINE OUT
CN119	645 005 8127	PLUG,6P
D1601	△408 007 9307	DIODE 1SR35-200A-HP
D1602	△408 007 9307	DIODE 1SR35-200A-HP
D1603	△408 007 9307	DIODE 1SR35-200A-HP
D1604	△408 007 9307	DIODE 1SR35-200A-HP
D1605	△408 007 9307	DIODE 1SR35-200A-HP
D1606	407 099 9707	ZENER DIODE MTZJ30D
D1607	407 127 3905	ZENER DIODE MTZJ5.6B
D1608	407 099 5907	ZENER DIODE MTZJ8.2C
D1631	407 007 9904	DIODE GMA01
or	407 012 4406	DIODE 1SS133
or	407 012 5809	DIODE 1SS176
HS161	614 215 9347	HEAT SINK,IC161 MTG.
HS162	614 215 9347	HEAT SINK,Q1601 MTG.
IC161	△409 254 7207	IC NJM7809FA
or	△409 066 4500	IC L7809ML
or	△409 066 4005	IC AN7809F
L1501	614 212 3171	INDUCTOR,FERITE
or	645 006 9864	INDUCTOR,80UH,1A
L1502	614 212 3171	INDUCTOR,FERITE
or	645 006 9864	INDUCTOR,80UH,1A
LUG01	614 217 7273	LUG
LUG02	614 217 7273	LUG
Q1501	405 011 8609	TR 2SC1740S-S
or	405 011 8500	TR 2SC1740S-R
or	405 015 6403	TR 2SC2785-F
or	405 015 6205	TR 2SC2785-E
or	405 014 5209	TR 2SC2458-GR
Q1502	405 011 8609	TR 2SC1740S-S
or	405 011 8500	TR 2SC1740S-R
or	405 015 6403	TR 2SC2785-F
or	405 015 6205	TR 2SC2785-E
or	405 014 5209	TR 2SC2458-GR
Q1503	405 082 4609	TR DTA123YS
Q1601	△405 077 9008	TR TIP29B
Q1631	405 011 8609	TR 2SC1740S-S
or	405 011 8500	TR 2SC1740S-R
or	405 015 6403	TR 2SC2785-F
or	405 015 6205	TR 2SC2785-E
or	405 014 5209	TR 2SC2458-GR
R1600	△402 045 6205	RESISTOR 0.56 J- 2W
R1605	△402 044 0907	FUSIBLE RES 1.0 J- 1/4W
RA106	614 218 0433	RESISTOR,100K OHM X 5
or	614 209 3634	RESISTOR,100K OHM X 5
SA161	411 021 5705	SCR S-TPG BIN 3X6MM, IC161 MTG.
SA162	411 021 5705	SCR S-TPG BIN 3X6MM, Q1601 MTG.

POWER TRANSFORMER P.W.BOARD ASSY

Ref. No.	Part No.	Description
87	614 272 5283	ASSY,PWB,POWER TRANSFORMER
	614 017 8203	TERMINAL BOARD
CN110	614 020 6586	SOCKET,6P
CN160	614 269 0659	SOCKET,6P,100 MM (CN110-CN111)
L1604	△614 229 0408	INDUCTOR,FERITE,1.2A
PR160	△645 005 9957	PROTECTOR,IC,1.5A 50V

PARTS LIST

CD CHANGER MECHANISM

(PM-CDRCH11) ... (N.S.P)

Ref. No.	Part No.	Description	Ref. No.	Part No.	Description
501	614 247 8899	BRACKET-M, CD MECHANISM SUPPORT, TOP	577	614 247 8837	COVER, FRONT SHUTTER
502	614 129 9099	LUG, ROTARY CHANGER MECHANISM, TOP	578	614 254 8011	ASSY, BRACKET-E, FRONT LED PWB
503	614 254 8035	ASSY, LEVER, ROLLER BACK RIGHT	579	614 129 9082	LUG, GROUND
504	614 254 8028	ASSY, LEVER, PLAY LEFT ROLLER	601	614 233 0227	PLATE, CHUCK
505	614 129 9341	LUG, WIRE FIX	603	614 253 7787	ASSY, LEVER, CHUCK
506	614 129 9068	LUG, GROUND	604	614 262 8928	MAGNET, CHUCK PRESSURE
507	614 247 9315	SPRING, TENSION, PLAY LEFT ROLLER	605	614 250 2648	ASSY, PULLEY, CHUCK
508	614 129 9105	LUG, WIRE FIX	606	614 247 8950	MOUNT-M, CD MECHANISM, CHUCK BRACKET
509	614 248 9307	BRACKET-E, PLAY SENSOR PWB	607	614 247 8943	MOUNT-M, CD MECHANISM HOLDER, FRONT
510	614 248 9314	BRACKET-E, PLAY LED	608	614 247 8929	BRACKET-M, CD MECHANISM HOLDER, REAR
511	614 129 9136	LUG, FRONT LEAD FIX	609	614 237 7031	CUSHION, RUBBER, FLOAT SIDE, CD MECHANISM
512	614 247 8967	MOUNT-M, TOP PANEL	610	614 247 4907	SPRING, COMP, FLOAT SIDE
521	614 248 9321	BRACKET-M, SHUTTER OPEN/CLOSE GEAR	611	614 247 8851	CHASSIS, SUB, CD MECHANISM HOLDER
522	614 249 4066	SPRING, TORSION, SHUTTER PUSH	612	614 195 6978	RUBBER CUSHION, FLOAT UP/DOWN
523	614 247 9049	GEAR, SHUTTER DRIVE GEAR		614 125 6443	CUSHION, 15X25X3MM, LEAD FIX
524	614 247 9124	GEAR, IDLER FOR SHUTTER		614 125 6443	CUSHION, 15X25X3MM, SHUTTER MOTOR
525	614 247 9131	GEAR, IDLER FOR SHUTTER	Y501	412 003 1708	SPECIAL SCREW, TOP BRACKET
526	614 247 8974	MOUNT-M, TOP PANEL	Y502	411 020 9902	SCR S-TPG BRZ+FLG 3X8MM, DISC GUIDE UP FIX
527	614 129 9136	LUG, LEAD MTG.	Y503	411 025 1901	SCR S-TPG PAN 2X3MM, LUG FIX
528	645 009 6167	ASSY, MOTOR SHUTTER	Y504	411 020 9902	SCR S-TPG BRZ+FLG 3X8MM, BRACKET-E
530	412 047 7308	SPECIAL WASHER, 8X19X0.3MM	Y505	411 023 2801	SCR S-TPG PAN 2.6X6MM, PLAY LED PWB
531	614 253 7299	BELT, SQUARE, PREVENT FOR NOISE	Y506	411 020 9407	SCR S-TPG BRZ+FLG 3X14MM, TOP PANEL COVER
532	614 247 9186	TURNTABLE, 24 DISCTABLE	Y507	411 020 9902	SCR S-TPG BRZ+FLG 3X8MM, LUG
or	614 265 1643		Y508	411 020 9902	SCR S-TPG BRZ+FLG 3X8MM, MECHANISM SENSOR PWB
533	614 247 8981	MOUNT-M, SWITCH LEVER DRIVE	Y521	411 022 4608	SCR S-TPG FLT 3X8MM, SHUTTER OPEN/CLOSE GEAR BRACKET
535	614 247 8912	BRACKET-M, CD MECHANISM BRACKET, BACK	Y522	411 020 9902	SCR S-TPG BRZ+FLG 3X8MM, SHUTTER DRIVE GEAR
536	614 247 8905	BRACKET-M, CD MECHANISM BRACKET, FRONT	Y523	411 021 6405	SCR S-TPG BIN 3X8MM, LAMP, LEFT, PWB
537	614 249 0525	SPRING, TENSION, PINCH LEVER	Y524	411 020 9902	SCR S-TPG BRZ+FLG 3X8MM, SHUTTER OPEN/CLOSE SWITCH
538	614 247 9216	LEVER, SWITCH	Y525	411 020 0701	SCR PAN PCS 1.7X4MM, SHUTTER MOTOR FIX
541	614 247 9261	SLIDE, CHUCK DRIVE	Y526	411 020 8905	SCR S-TPG BRZ+FLG 3X10MM, TOP PANEL COVER
542	614 247 9278	SLIDE, DISC	Y531	411 022 8408	SCR S-TPG PAN 2X8MM, MOUNT-MFIX
543	614 247 9131	GEAR, LOADING, 2, FRONT	Y533	411 020 9902	SCR S-TPG BRZ+FLG 3X8MM, CD MAIN PWB
544	614 247 9124	GEAR, LOADING, 3, FRONT	Y534	411 020 9902	SCR S-TPG BRZ+FLG 3X8MM, BRACKET
545	614 247 9117	GEAR, LOADING, 4, FRONT	Y535	411 020 8905	SCR S-TPG BRZ+FLG 3X10MM, BRACKET
546	614 247 9087	GEAR, SLIDE CAM	Y536	411 020 9902	SCR S-TPG BRZ+FLG 3X8MM, LEVER
547	614 247 9070	GEAR, SLIDE DRIVER M-1	Y541	411 020 9902	SCR S-TPG BRZ+FLG 3X8MM, SLIDE FIX
548	614 247 9063	GEAR, SLIDE DRIVER M-2	Y542	411 020 9902	SCR S-TPG BRZ+FLG 3X8MM, CHUCKING SWITCH PWB
549	614 253 9071	ASSY, GEAR, SLIP, FRONT	Y543	411 020 9902	SCR S-TPG BRZ+FLG 3X8MM, DISC SLIDE
550	614 247 9278	SLIDE, DISC			
551	614 253 9071	ASSY, GEAR, SLIP, PLAY			
552	614 247 8882	BRACKET-E, SENSOR			
553	614 247 9056	GEAR, TURN TABLE			
554	614 247 9148	PULLEY, TURN TABLE			
555	614 253 6957	ASSY, MOTOR, TURN TABLE MOTOR			
556	614 247 9209	BELT, SQUARE, TURN TABLE MOTOR			
557	614 255 4999	ASSY, MOTOR, FRONT LOADING			
558	614 255 4999	ASSY, MOTOR, CHUCKING			
559	614 255 4999	ASSY, MOTOR, LOADING			
561	614 247 8844	CHASSIS, BASE			
562	614 249 9351	ASSY, ROLLER, DISC TABLE			
563	614 249 4035	SHAFT, DISC TABLE ROLLER			
571	614 129 9099	LUG, GROUND			
572	614 247 8875	BRACKET-E, FRONT SENSOR PWB			
573	614 253 7305	SPRING, TORSION, UPPER			
574	614 247 9162	BEARING, ROLLER SHAFT SUPPORT			
575	614 247 9339	SPRING, TORSION, LOWER			
576	614 250 2662	ASSY, ROLLER, FRONT, RIGHT			

PARTS LIST

Ref. No.	Part No.	Description
Y544	411 020 9902	SCR S-TPG BRZ+FLG 3X8MM, LOCK SLIDE SWITCH PWB
Y545	620 123 0772	SCREW WASHER, 2.6X6X0.8MM, GEAR
Y546	411 020 9902	SCR S-TPG BRZ+FLG 3X8MM, DISC SLIDE
Y547	411 020 9902	SCR S-TPG BRZ+FLG 3X8M, TURN TABLE INITIAL SWITCH PWB
Y548	411 023 2207	SCR S-TPG PAN 2.6X4MM, DISC STOP SENSOR PWB
Y549	411 020 9902	SCR S-TPG BRZ+FLG 3X8MM, PWB BRACKET
Y550	411 020 9902	SCR S-TPG BRZ+FLG 3X8MM, FRONT LOADING/TURNTABLE/CHUCKING/PLAY LOADING MOTOR
Y551	411 087 6005	WASHER, 2.6X7.5X0.5MM
Y552	411 023 3303	TURN TABLE GEAR MTG.
Y561	412 003 1708	SPECIAL SCREW, TURN TABLE GEAR MTG.
Y562	411 119 9103	DISC TABLE ROLLER
Y563	411 119 9103	SCR S-TPG PAN 2X16MM, GEAR(548), BOSS
Y571	411 023 2801	SCR S-TPG PAN 2X16MM, GEAR(547), BOSS
Y572	411 020 9902	SCR S-TPG PAN 2.6X6MM, FRONT SENSOR PWB
Y573	411 020 9902	SCR S-TPG BRZ+FLG 3X8MM, FRONT SHUTTER COVER, UPPE
Y574	411 020 9902	SCR S-TPG BRZ+FLG 3X8MM, FRONT SHUTTER COVER, LOWE
Y575	411 020 9902	SCR S-TPG BRZ+FLG 3X8MM, FRONT BRACKET
Y576	411 020 9902	SCR S-TPG BRZ+FLG 3X8MM, FRONT BRACKET
Y576	411 023 2801	SCR S-TPG PAN 2.6X6MM, FRONT LED PWB
Y601	411 022 7500	SCR S-TPG PAN 2X4MM, CHUCK PLATE FIX
Y602	412 003 1708	SPECIAL SCREW, CHUCK LEVER FIX
Y603	411 020 9902	SCR S-TPG BRZ+FLG 3X8MM, BRACKET-M FIX

PLAY SENSOR P.W.BOARD ASSY

Ref. No.	Part No.	Description
581	614 249 5766	ASSY, PWB, PLAY SENSOR
D1836	407 159 6004	PHOTO DIODE PT380F
CN190	645 005 8226	PLUG, 3P
	614 252 0956	COVER, SENSOR

PLAY LED P.W.BOARD ASSY

Ref. No.	Part No.	Description
582	614 249 5759	ASSY, PWB, PLAY LED (N.S.P)
D1837	408 018 8108	LED, SRZ-935A-1-BC-T1
CN191	645 006 0908	PLUG, 2P
	614 252 0956	COVER, SENSOR

MECHANISM SENSOR P.W.BOARD ASSY

Ref. No.	Part No.	Description
583	614 249 5780	ASSY, PWB, MECHANISM SENSOR
CN157	645 005 8226	PLUG, 3P
or	645 009 6433	
CN158	645 006 0908	PLUG, 2P
or	646 009 6426	
CN159	645 006 0908	PLUG, 2P
or	645 009 6426	
CN160	645 006 0953	PLUG, 8P
or	645 009 6488	
IC184	△409 207 7506	IC MLC74HC14A
or	△409 162 5302	IC HD74HC14P
IC185	△409 207 7506	IC MLC74HC14A
or	△409 162 5302	IC HD74HC14P

MOTOR DRIVER P.W.BOARD ASSY

Ref. No.	Part No.	Description
584	614 249 5773	ASSY, PWB, MOTOR DRIVER
CN150	645 005 7366	PLUG, 2P
or	645 007 0051	
CN151	645 006 0861	PLUG, 7P
or	645 007 0105	
CN152	645 005 8127	PLUG, 6P
or	645 007 0099	
CN153	645 006 8110	PLUG, 4P
or	645 007 0076	
CN154	645 005 7366	PLUG, 2P
or	645 007 0051	
CN155	645 005 7373	PLUG, 3P
or	645 007 0068	
CN156	614 227 7836	SOCKET, 32P
D1820	407 050 1009	ZENER DIODE GZA3.3Y
D1821	407 050 0606	ZENER DIODE GZA3.0X
D1822	407 050 1009	ZENER DIODE GZA3.3Y
D1823	407 049 8507	ZENER DIODE GZA2.2X
D1824	407 005 4505	DIODE DS442X
or	407 013 7109	DIODE 1S2473
or	407 013 1701	DIODE 1S1588
IC181	△409 127 1400	IC LB1648
IC182	△409 127 1400	IC LB1648
IC183	△409 127 1400	IC LB1648
Q1810	405 001 9302	TR 2SA1020-Y
Q1811	405 000 4407	TR DTC124ES
Q1812	405 000 4407	TR DTC124ES
RA181	614 218 0464	RESISTOR, 100K OHM X 8
or	614 209 3696	RESISTOR, 100K OHM X 8
S1810	614 220 5655	SWITCH, TACT, RESET

PARTS LIST

LAMP, RIGHT P.W.BOARD ASSY

Ref. No.	Part No.	Description
585	614 266 1529	ASSY,PWB,LAMP,RIGHT
CN140	614 035 4911	SOCKET,2P
or	614 237 9752	SOCKET,2P
CN141	614 035 4911	SOCKET,2P
or	614 237 9752	SOCKET,2P
PL161	614 253 4687	LAMP,8V 100MA
or	614 255 8157	LAMP,8V 100MA

LAMP, LEFT P.W.BOARD ASSY

Ref. No.	Part No.	Description
586	614 266 1536	ASSY,PWB,LAMP,LEFT
CN142	614 035 4911	SOCKET,2P
or	614 237 9752	SOCKET,2P
PL162	614 253 4687	LAMP,8V 100MA
or	614 255 8157	LAMP,8V 100MA

SHUTTER OPEN / CLOSE SWITCH P.W.BOARD ASSY

Ref. No.	Part No.	Description
587	614 249 5728	ASSY,PWB,SHUTTER OPEN/CLOSE SWITCH
CN187	645 005 7373	PLUG,3P,SIDE
D1808	407 012 4406	DIODE 1SS133, CLOSE END SWITCH
or	407 007 9904	DIODE GMA01, CLOSE END SWITCH
D1809	407 012 4406	DIODE 1SS133, CLOSE END SWITCH
or	407 007 9904	DIODE GMA01, CLOSE END SWITCH
S1808	614 249 1355	SWITCH,LEVER, SHUTTER CLOSE END
S1809	614 249 1355	SWITCH,LEVER, SHUTTER OPEN END

Ref. No.	Part No.	Description
D1102	407 007 9904	DIODE GMA01
or	407 012 4406	DIODE 1SS133
or	407 153 6109	DIODE 1SS119-041
D1401	407 007 9904	DIODE GMA01
or	407 012 4406	DIODE 1SS133
or	407 153 6109	DIODE 1SS119-041
IC101	409 245 4802	IC LA9210M
IC102	409 317 8509	IC BA6398FP
IC104	409 261 0505	IC LC7867E
IC105	409 284 5808	IC SM5871AS
IC106	409 228 9206	IC NJM2100M
IC151	△ 409 039 9204	IC NJM78L05A
L1401	614 028 4133	FILTER
Q1101	405 006 1905	TR 2SA933S-S
Q1102	405 011 7503	TR 2SC1740-S
Q1103	405 000 4407	TR DTC124ES
Q1301	405 001 9302	TR 2SA1020-Y
Q1504	405 001 9302	TR 2SA1020-Y
Q1505	405 000 4407	TR DTC124ES
SVR11	645 001 9319	VR,SEMI 10K N
X101	614 231 2667	RESONATOR,16.93MHZ

CHUCKING SWITCH P.W.BOARD ASSY

Ref. No.	Part No.	Description
589	614 249 5681	ASSY,PWB,CHUCKING SWITCH
CN181	645 006 0861	PLUG,7P
CN182	645 005 8110	PLUG,4P
D1801	407 012 4406	DIODE 1SS133
or	407 007 9904	DIODE GMA01
D1802	407 012 4406	DIODE 1SS133
or	407 007 9904	DIODE GMA01
S1801	614 249 1355	SWITCH,LEVER,CHUCKING OFF
S1802	614 249 1355	SWITCH,LEVER,CHUCKING ON

CD MAIN P.W.BOARD ASSY

Ref. No.	Part No.	Description
588	614 266 4322	ASSY,PWB,CD MAIN
	614 256 7852	SHIELD
	614 125 6443	CUSHION,15X25X3MM
C1101	404 060 2804	OS-SOLID 47U M 10V
C1108	403 063 5706	POLYESTER 8200P K 50V
C1151	404 060 2804	OS-SOLID 47U M 10V
CN101	614 227 7706	SOCKET,13P
CN102	645 005 8127	PLUG,6P
or	645 007 0099	
CN103	614 234 0431	SOCKET,16P
CN104	645 005 7366	PLUG,2P
or	645 007 0051	
CN105	645 005 8110	PLUG,4P
or	645 007 0075	
CN106	645 005 8110	PLUG,4P
or	645 007 0075	
D1101	407 007 9904	DIODE GMA01
or	407 012 4406	DIODE 1SS133
or	407 153 6109	DIODE 1SS119-041

LOCK SLIDE SWITCH P.W.BOARD ASSY

Ref. No.	Part No.	Description
590	614 249 5698	ASSY,PWB,LOCK SLIDE SWITCH
CN183	645 006 0939	PLUG,6P,SIDE
CN184	645 005 8226	PLUG,3P,SENSOR
D1804	407 012 4406	DIODE 1SS133,FRONT RESET SWITCH
or	407 007 9904	DIODE GMA01,FRONT RESET SWITCH
D1805	407 012 4406	DIODE 1SS133,PLAY RESET SWITCH
or	407 007 9904	DIODE GMA01,PLAY RESET SWITCH
S1804	614 249 1355	SWITCH,LEVER,DISC SLIDE RESET (F)
S1805	614 249 1355	SWITCH,LEVER,DISC SLIDE RESET (P)

PARTS LIST

TURNTABLE INITIAL SWITCH P.W.BOARD ASSY

Ref. No.	Part No.	Description
591	614 249 5711	ASSY,PWB,TURNTABLE INITIAL SWITCH
CN186	645 005 7366	PLUG,2P,SIDE PWB
D1807	407 012 4406	DIODE 1SS133,RESET SWITCH
or	407 007 9904	DIODE GMA01,RESET SWITCH
S1807	614 250 0101	SWITCH,LEVER,POSITION DETECT

DISC STOP SENSOR P.W.BOARD ASSY

Ref. No.	Part No.	Description
592	614 249 5704	ASSY,PWB,DISC STOP SENSOR
CN185	614 224 9932	ASSY,CONNECTOR-S,3P
D1818	407 137 8006	PHOTO COUPLE GP1A53HR

FRONT SENSOR P.W.BOARD ASSY

Ref. No.	Part No.	Description
593	614 249 5742	ASSY,PWB,FRONT SENSOR
	614 252 0956	COVER,SENSOR
CN188	645 006 0953	PLUG,8P
D1830	407 159 6004	PHOTO DIODE PT380F, DISC CHECK
D1831	407 159 6004	PHOTO DIODE PT380F, DISC CHECK
D1832	407 159 6004	PHOTO DIODE PT380F, DISC CHECK
D1833	407 159 6004	PHOTO DIODE PT380F, DISC CHECK
D1834	407 159 6004	PHOTO DIODE PT380F, DISC CHECK
D1835	407 159 6004	PHOTO DIODE PT380F, DISC CHECK

FRONT LED P.W.BOARD ASSY

Ref. No.	Part No.	Description
594	614 249 5735	ASSY,PWB,FRONT LED
	614 252 0956	COVER,SENSOR
CN189	645 006 0908	PLUG,2P,FRONT LED PWB
D1810	408 018 8108	LED SRZ-935A-1-BC-T1
D1811	408 018 8108	LED SRZ-935A-1-BC-T1
D1812	408 018 8108	LED SRZ-935A-1-BC-T1
D1813	408 018 8108	LED SRZ-935A-1-BC-T1
D1814	408 018 8108	LED SRZ-935A-1-BC-T1
D1815	408 018 8108	LED SRZ-935A-1-BC-T1

CD MECHANISM (CDBM94D2SP) ... (N.S.P)

Ref. No.	Part No.	Description
651	614 267 0408	ASSY,CHASSIS,BASE MECHANISM
652	614 237 7024	SHAFT,PICKUP RAIL
653	614 262 2599	GEAR,RACK,PICKUP
654	614 238 6934	SPRING,COMP,PICKUP RACK GEAR
655	645 005 6444	PICKUP,LASER SF-P100PS
656	614 237 7116	GEAR,SLED GEAR
657	614 237 7109	GEAR,SLED,RETARD 2
658	614 237 7093	GEAR,SLED,RETARD 1
659	645 007 7814	ASSY,MOTOR,SLED MOTOR
661	614 253 5295	ASSY,CONNECTOR-S,6P,MOTOR
or	614 273 9570	
662	614 249 8699	CORD,13P,PICKUP
Y651	411 044 8004	SCR PAN+SW 2X8MM, SLED MOTOR FIX
Y652	411 152 4301	SCR S-TPG PAN PCS 1.7X6MM, PICK RACK GEAR FIX
Y653	412 047 3904	SPECIAL SCREW,SLED GEAR FIX

SPINDLE / SLED MOTOR P.W.BOARD ASSY

Ref. No.	Part No.	Description
660	614 251 6485	ASSY,PWB,SPINDLE/SLED MOTOR
CN001	645 006 0939	PLUG,6P,MOTOR CONNECTOR
or	645 009 6464	
S001	614 231 4005	SWITCH,LEAF,LIMIT

EXPLODED VIEW (CD MECHANISM)

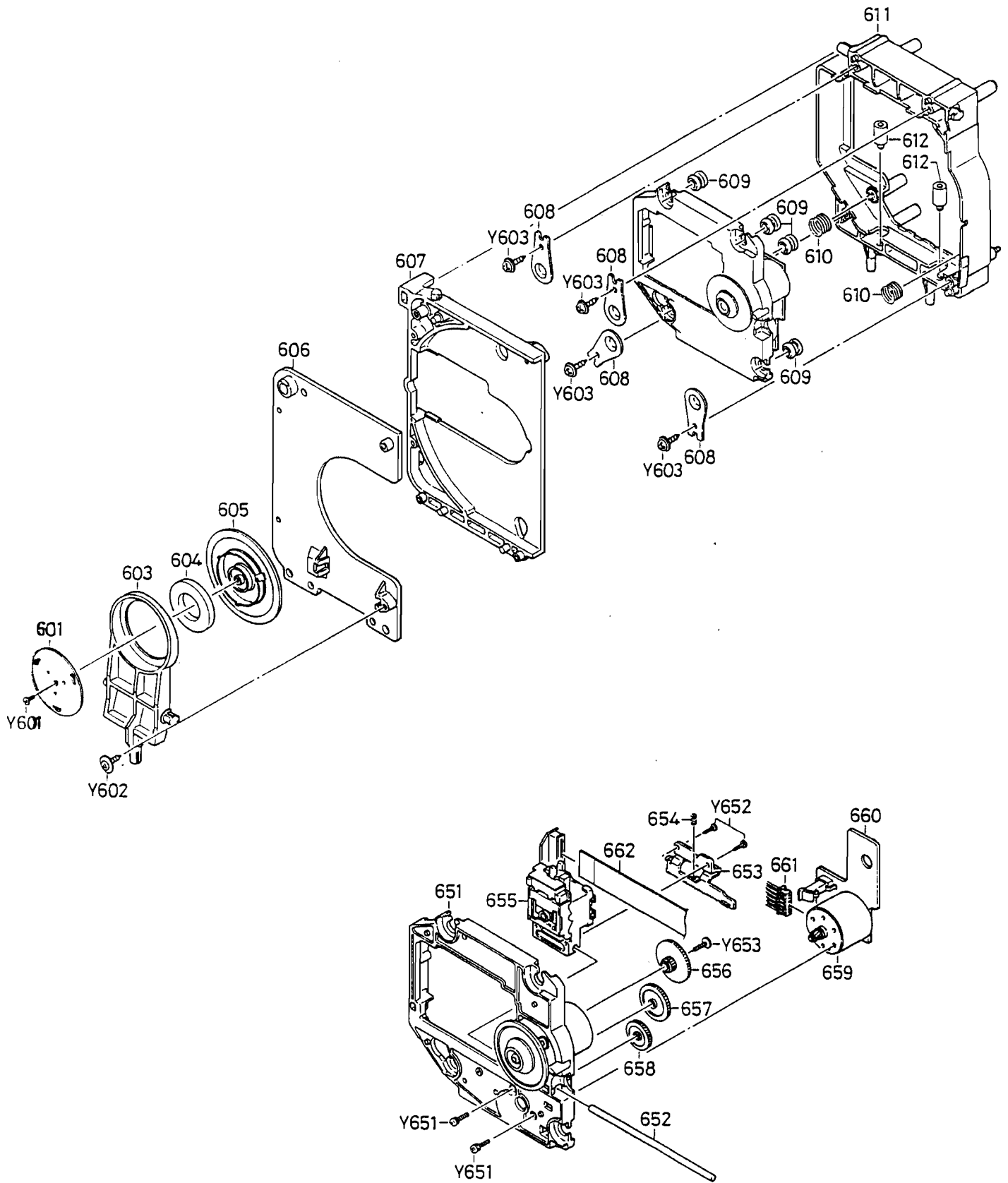

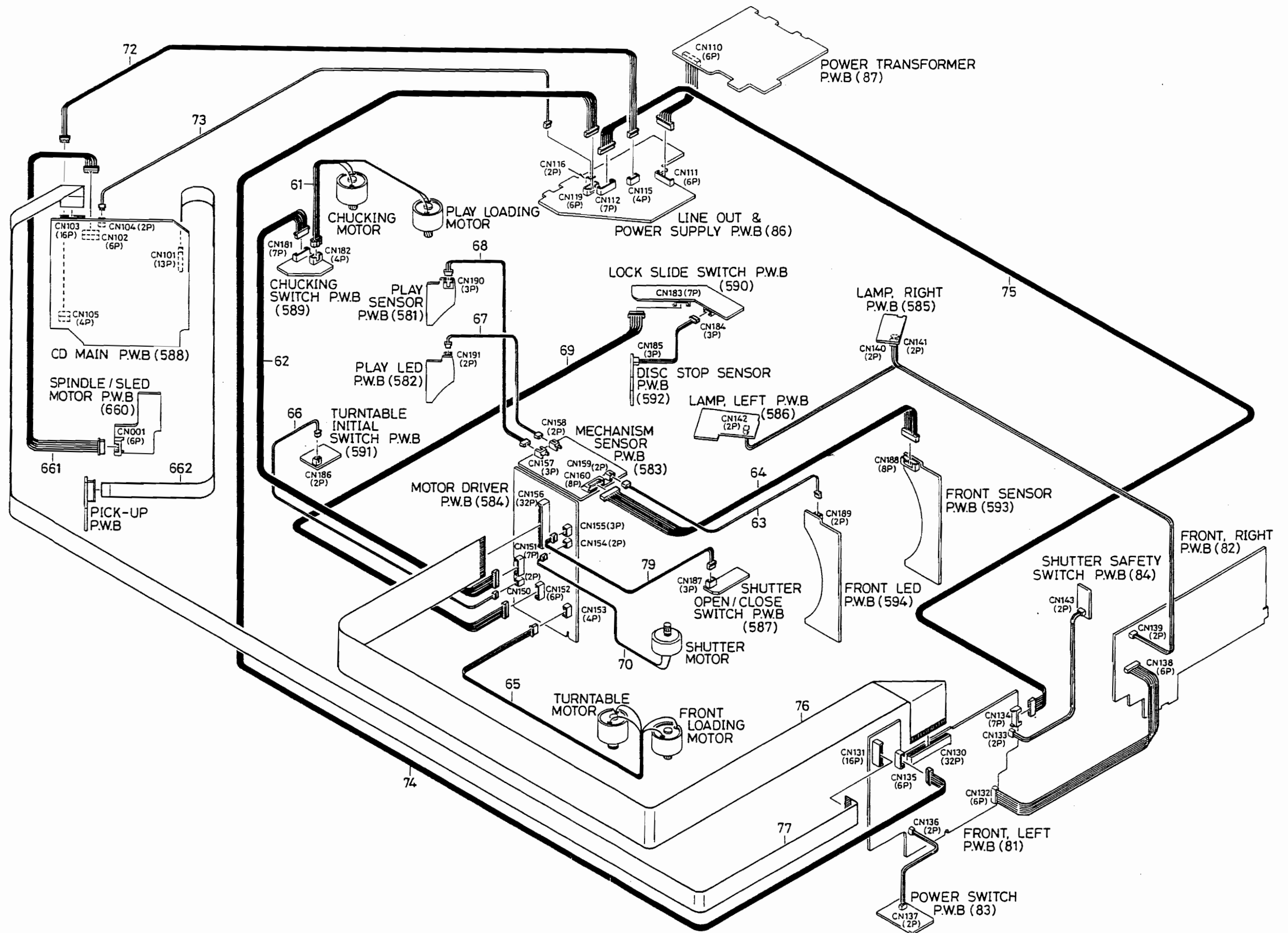

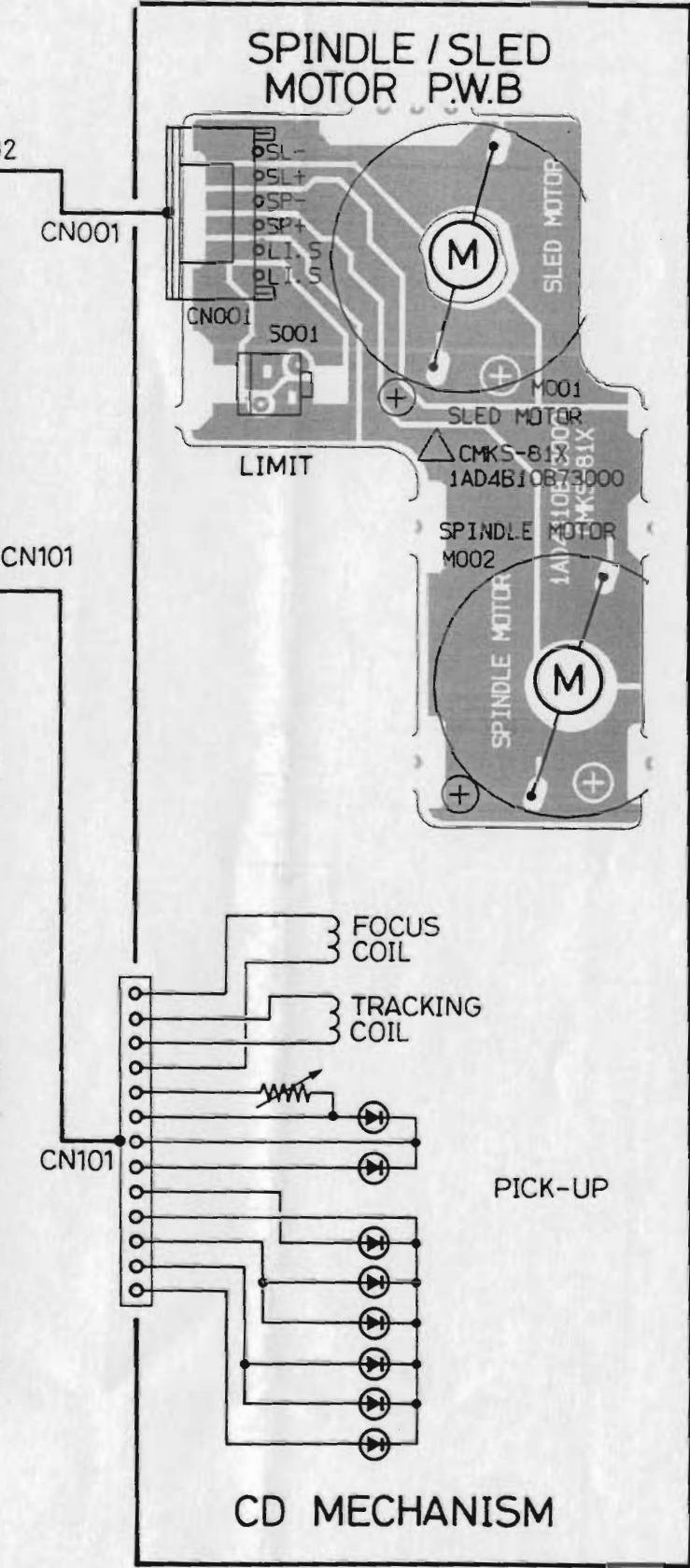
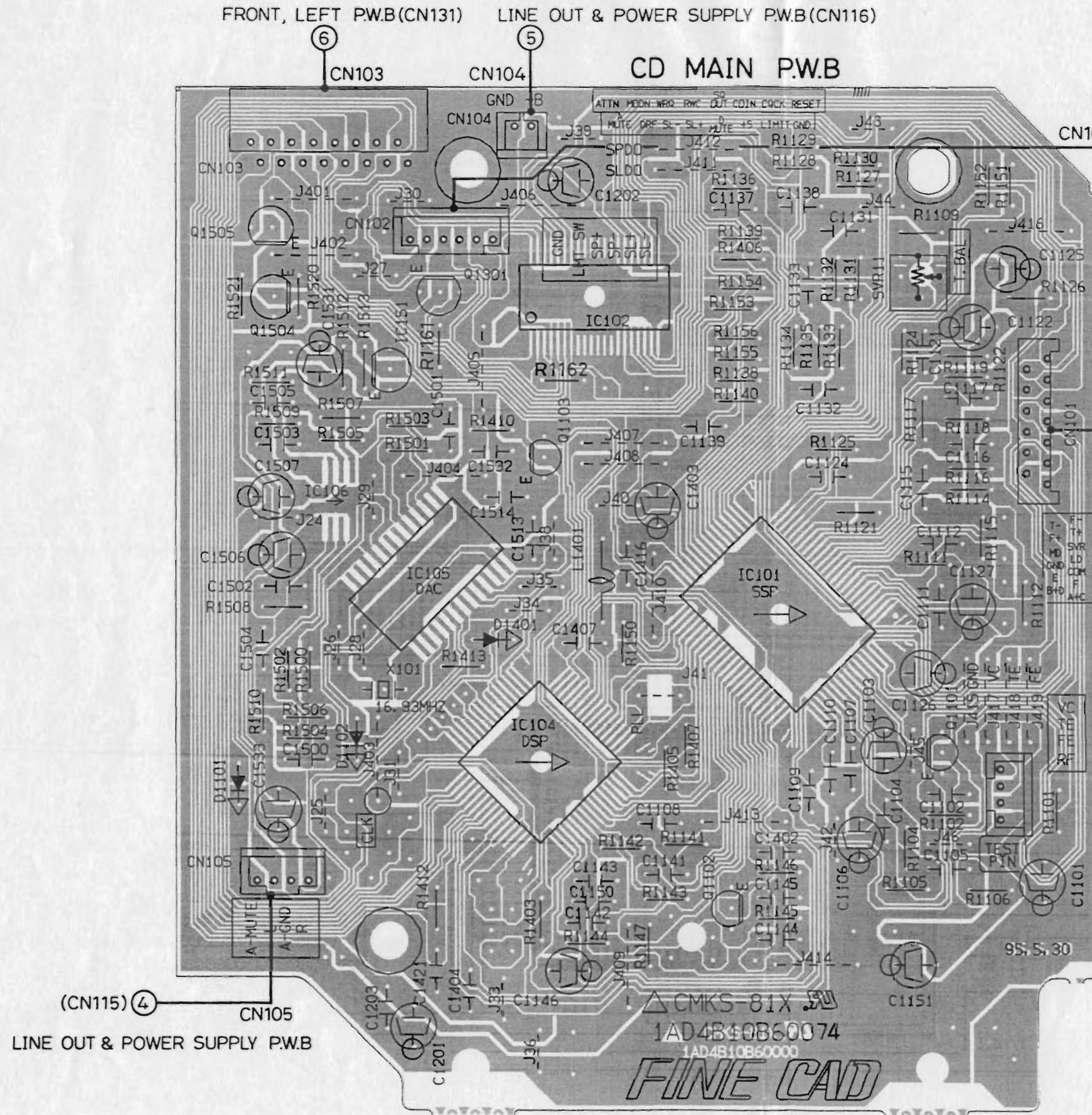

WIRING DIAGRAM (SYSTEM CONTROL & OPERATION SWITCH)

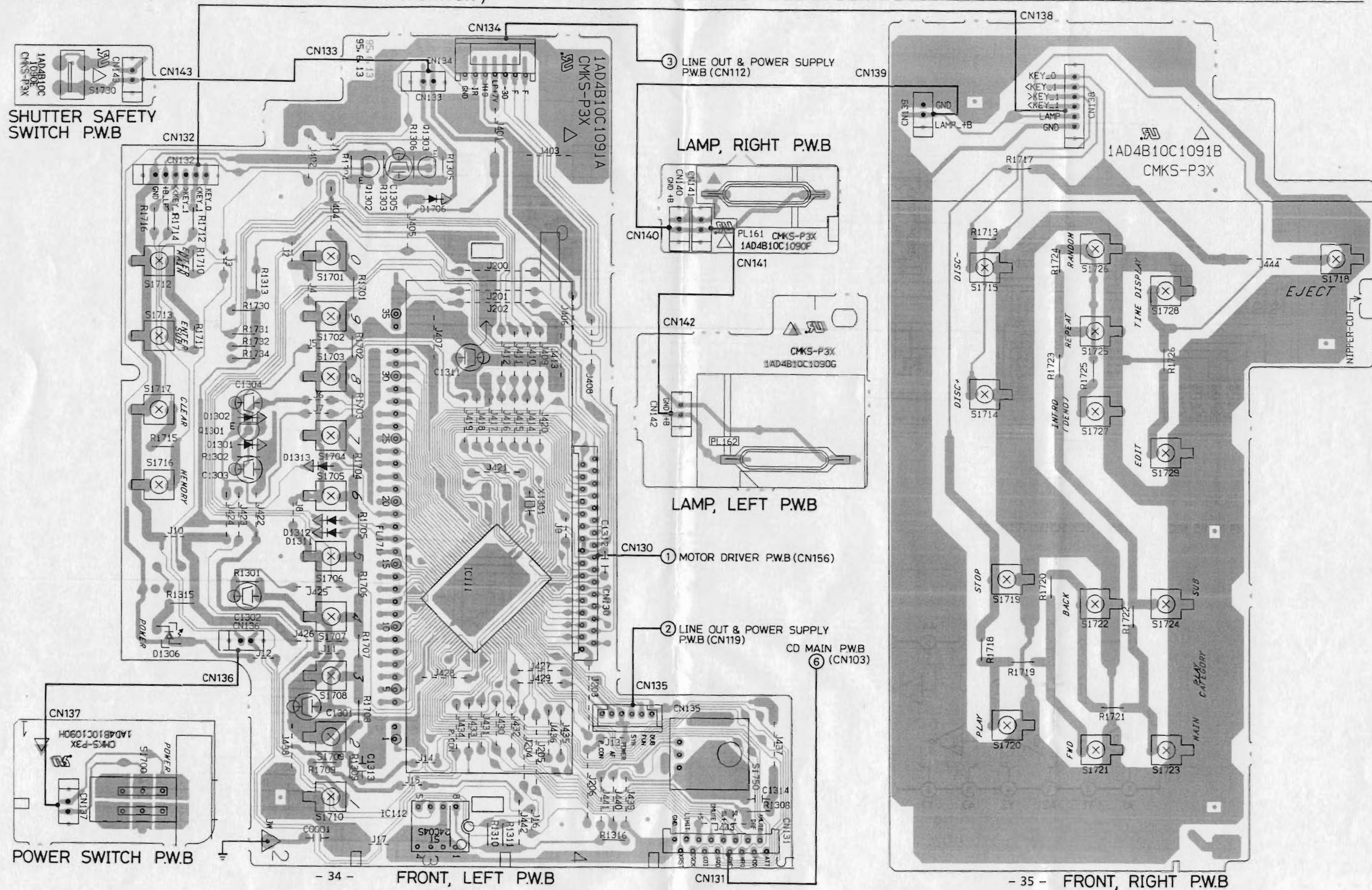

SCHEMATIC DIAGRAM (MECHANISM CONTROL)

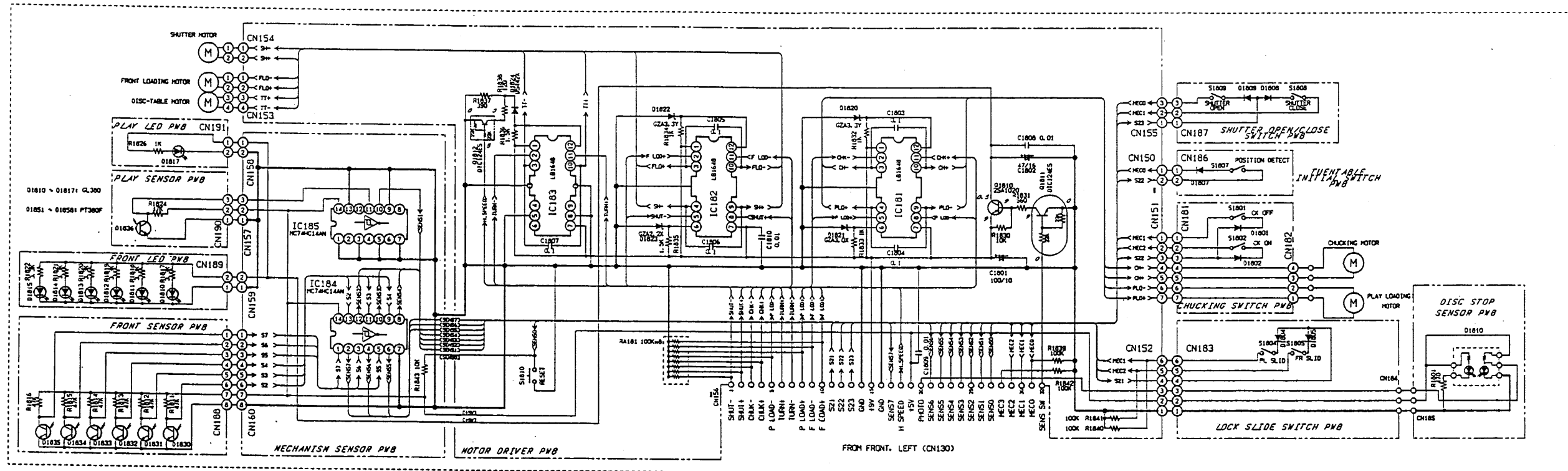

IC181~IC183 LB1648 (MOTOR DRIVER)

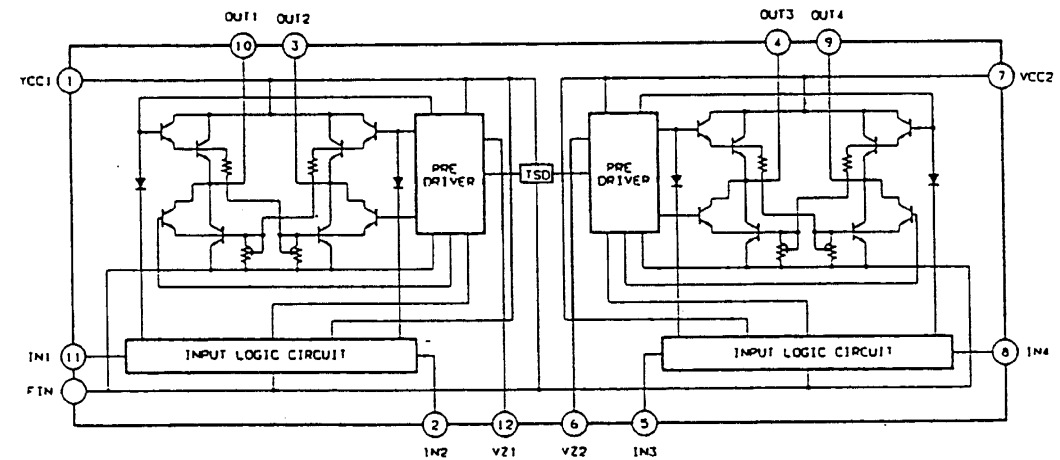

IN1	IN2	OUT1	OUT2	IN3	IN4	OUT3	OUT4
0	0	OPEN	OPEN	0	0	OPEN	OPEN
1	0	H	L	1	0	H	L
0	1	L	H	0	1	L	H
1	1	L	L	1	1	L	L

IC184,IC185 MC74HC14AN (HEX SCHMITT INVERTER)

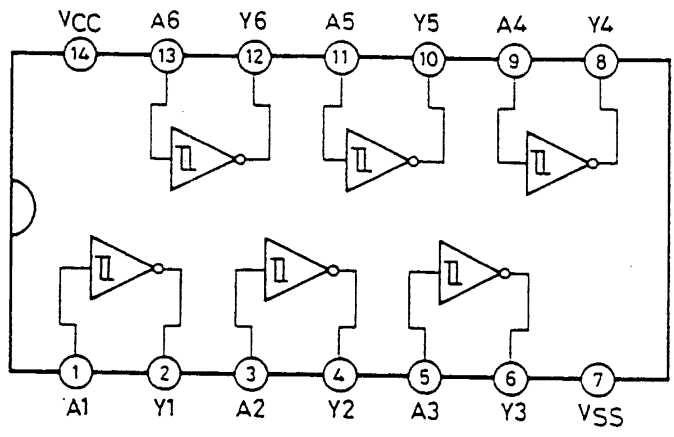

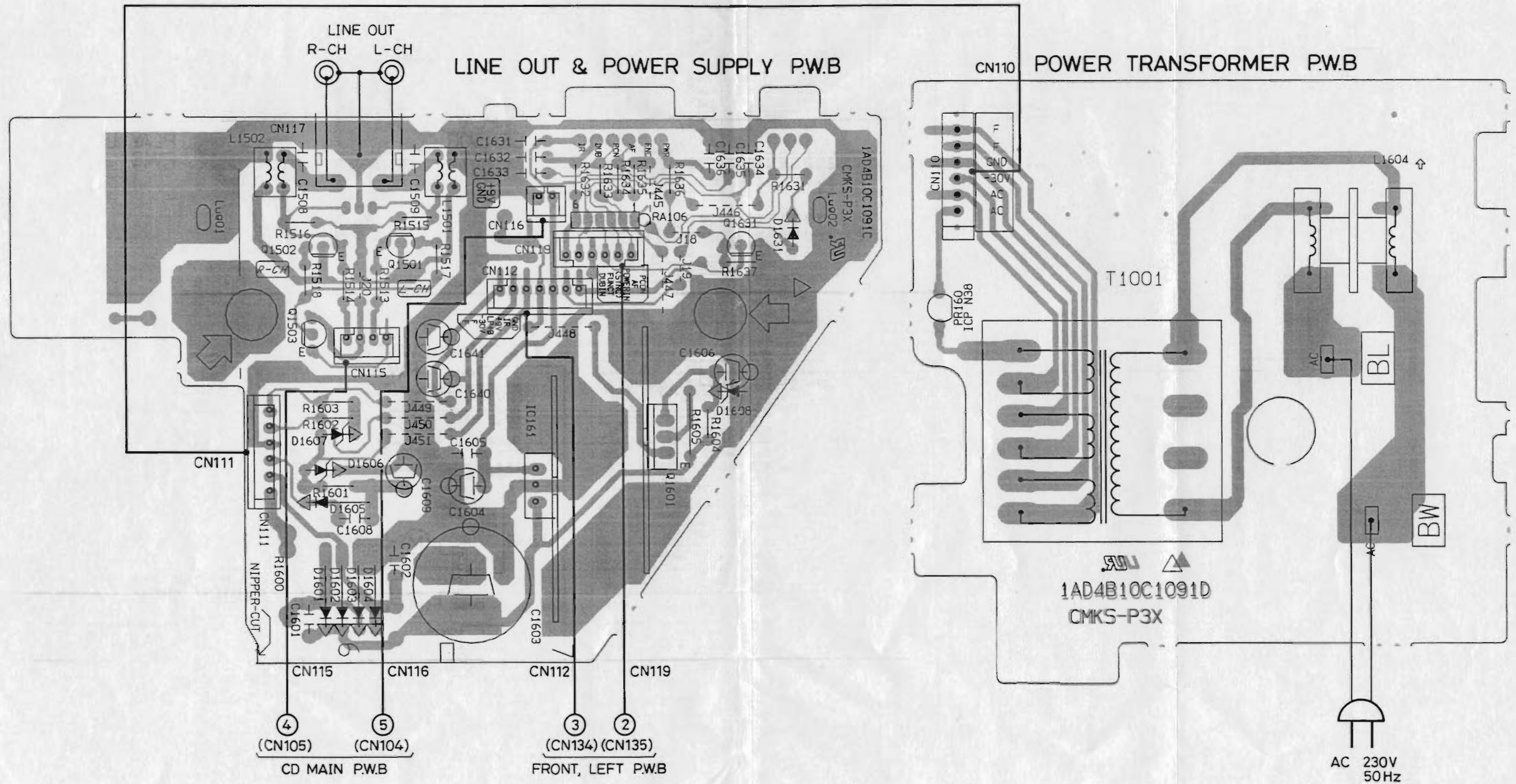

WIRING DIAGRAM (MOTOR DRIVER & SENSOR)

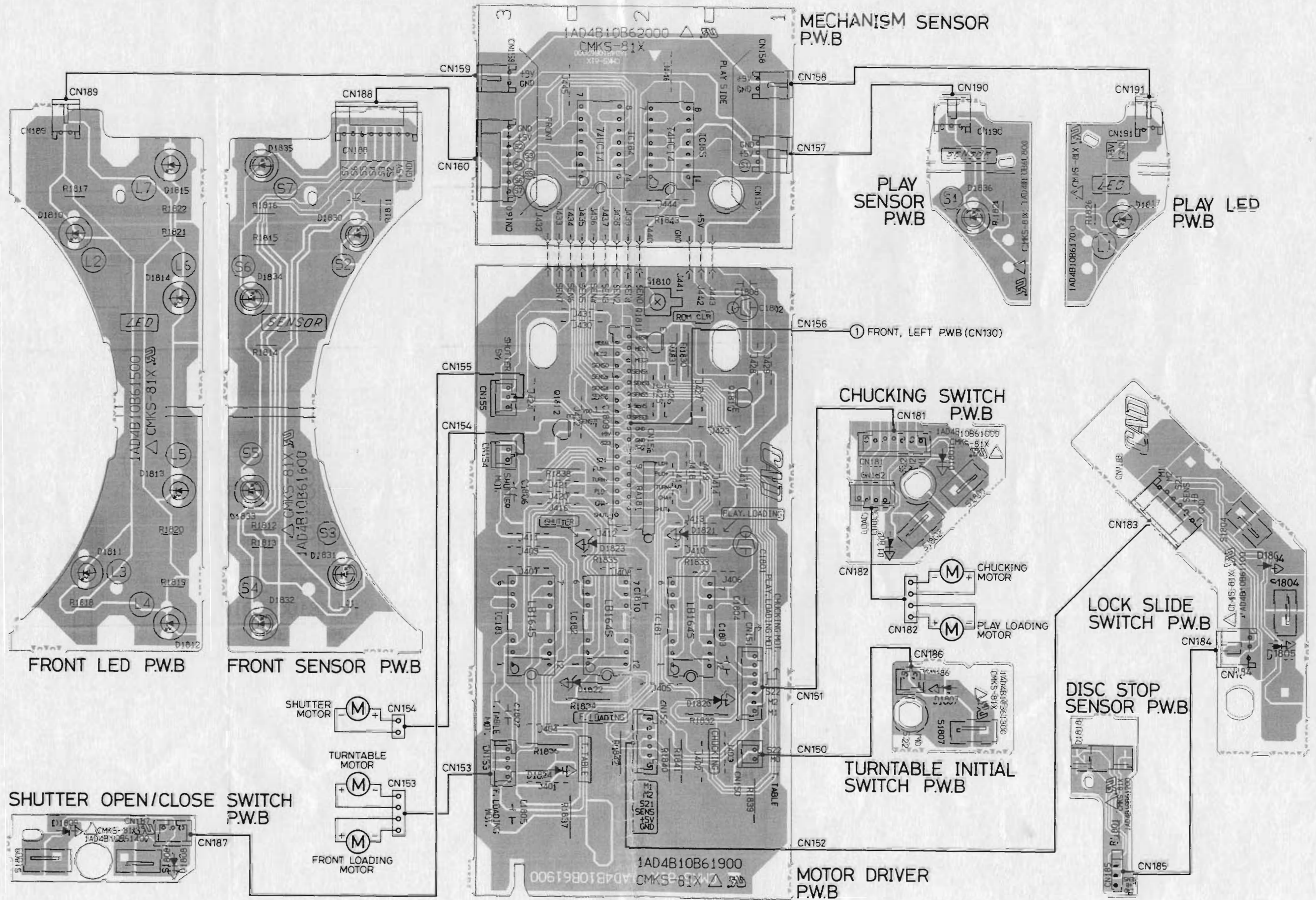

IC BLOCK DIAGRAM & DESCRIPTION

IC104 LC7867KE (CD PLAYER SIGNAL & SERVO CONTROL)

No	PIN NAME	I/O	DESCRIPTION	No	PIN NAME	I/O	DESCRIPTION
1	TEST1	I	For TEST. Normal time is non connection.	33	LRCLK	O	Output of signal to DAC, Signal of Latch & L/R select, Signal for Sampling Hold
2	AO	O	Input from VCO output in LA9210 (8.6436MHz)	34	SMP	O	Output of signal to DAC, Signal of Latch & L/R select, Signal for Sampling Hold
3	AI	I	Phase comparison output of VCO and EFM signal.	35	DFOUT	O	Output of signal to DAC, Signal of Latch & L/R select, Signal for Sampling Hold
4	PDO	O		36	DACLK	O	Output of signal to DAC, Signal of Latch & L/R select, Signal for Sampling Hold
5	V55		GND	37	TEST6	O	For TEST. Normal time is non connection.
6	EFMO	O	Negative output through amplitude limiter. Antiphase of EFMO. This signal use SLICE LEVEL CONTROL.	38	LRSY	O	For output of signal that Comply with CD-ROM
7	EFMO	O	Positive output through amplitude limiter. Antiphase of EFMO. This signal use SLICE LEVEL CONTROL.	39	CK2	O	For output of signal that Comply with CD-ROM
8	EFMI	I	Inputting HF signal of 1~2V _{p-p} . This signal use SLICE LEVEL CONTROL.	40	ROMO	O	For output of signal that Comply with CD-ROM
9	TEST2	I	For TEST. Normal time is non connection.	41	C2FLC	O	For output of signal that Comply with CD-ROM
10	CLV+	O	Output for DISC MOTOR CONTROL.	42	C2F	O	For output of signal that Comply with CD-ROM
11	CLV-	O	Output for DISC MOTOR CONTROL.	43	DOUT	O	Output of DIGITAL OUT
12	V/P	O	CLV rough Servo time : Output "H" Phase control time : Output "L"	44	SBSY	O	Synchronizing signal of sub-code block.
13	FOCS	O	Output "H" : Lens pull up with slowly than stop the Focus Servo. If FZD generate, it reset output of FOCS. For lead-in of Focus	45	EFLG	O	For correction monitor of C1, C2, single, double.
14	FST	O		46	PW	O	SFSY is Synchronizing signal of sub-code & frame. Clock of eighth send to SBCK then read out the sub-code of P, Q, R, S, T, U, V, & W.
15	FZD	I		47	SBCK	I	
16	HFL	I	Comply with command of track jump, it oscillate kick Pulse, JP+ & JP-. It jump the prescribed number of track (1,4,16,64).	48	FSX	O	Output of Synchronizing signal (7.35KHz)
17	TES	I	Comply with command of track jump, it oscillate kick Pulse, JP+ & JP-. It jump the prescribed number of track (1,4,16,64).	49	WRQ	O	Data sub-code Q pass the CRC check then WRQ do "H". It detect at external. Data read out from SQOUT by send the CQCK. RWC set the "H" by Micro Processor then it let command by send with Synchronizing CQCK command data.
18	PCK	O	PCK Monitor (4.3218MHz)	50	RWC	I	
19	FSEQ	O	SYNC (FS of truth) detected from EFM signal = SYNC of counter : "H" (Latch Output during in 1 frame)	51	SQOUT	O	
20	TOFF	O	Comply with command of track jump, it oscillate kick Pulse, JP+ & JP-. It jump the prescribed number of track (1,4,16,64).	52	COIN	I	
21	TGL	O		53	CQCK	I	
22	THLD	O		54	RES	I	Turn on the Power Supply time : Once "L"
23	TEST3	I	For TEST. Normal time is non connection.	55	M/L	I	Data of SQOUT want at the LBS first time : M/L set the "L".
24	VDD		+5V	56	LASER	O	This output can control at Serial Control from Micro Processor
25	JP+	O	Comply with command of track jump, it oscillate kick Pulse, JP+ & JP-. It jump the prescribed number of track (1,4,16,64).	57	16M	O	16M Output (16.9344MHz)
26	JP-	O		58	4M	O	4M Output (4.2336MHz)
27	DEM	I	For adjustment of production process. Sound on function.	59	CONT	O	This output can control at Serial Control from Micro Processor
28	TEST4	I	For TEST. Normal time is non connection.	60	TEST5	I	For TEST. Normal time is non connection.
29	EMPH	O	Output is "H" time, it need de-emphasis	61	CS	I	Chip select Terminal. This terminal "L" : LC7866NE is active (Internal Resistor : Pull Down)
30	NC	I		62	XIN	I	Connection Terminal of crystal oscillation (16.9344MHz)
31	SMP2	O	Output of signal to DAC, Signal of Latch & L/R select, Signal for Sampling Hold	63	XOUT	O	Connection Terminal of crystal oscillation (16.9344MHz)
32	SMP1	O		64			

IC BLOCK DIAGRAM & DESCRIPTION

IC105 SM5871AS (D/A CONVERTER)

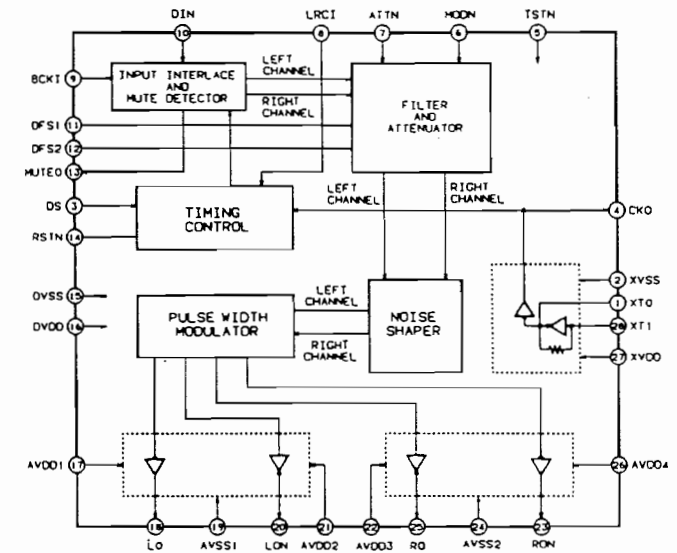

No.	Pin Name	Description
1	XT0	Crystal Oscillator Output
2	XVSS	Clock Ground
3	DS	Normal / Double Speed Select Input
4	CKO	Clock Input
5	TSTN	Test Input
6	MODN	Mode Select Input
7	ATTN	Soft Mute Control Input
8	LRCI	Data Sample Rate Clock Input
9	BCLK	Bit Clock Input
10	DIN	Serial Data Input
11	DSF1	De-Emphasis Select Input
12	DSF2	De-Emphasis Select Input
13	MUTED	Mute Detect Output
14	RSTN	Reset Input
15	DVSS	Digital Ground
16	DVDD	5 V Digital Supply
17	AVDD1	Analog Supply 1
18	LO	Left-Channel Positive PWM Output
19	AVSS1	Analog Ground 1
20	LON	Left-Channel Negative PWM Output
21	AVDD2	Analog Supply 2
22	AVDD3	Analog Supply 3
23	RON	Right-Channel Negative PWM Output
24	AVSS2	Analog Ground 2
25	RO	Right-Channel Positive PWM Output
26	AVDD4	Analog Supply 4
27	XVDD	Clock Supply
28	XT1	Crystal Oscillator or External Clock Input

IC106 NJM2100 (OP AMP.)

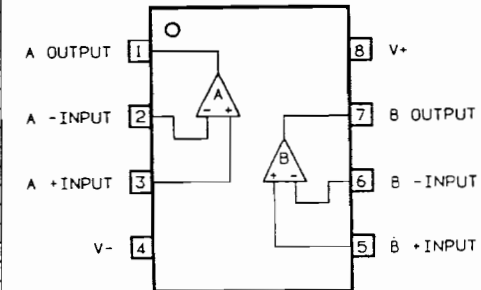

IC VOLTAGES

IC101 LA9210M

(V)

Pin No.	1	2	3	4	5	6	7	8	9	10	11	12	13	14	15
STOP	0	0	2.5	2.5	2.5	2.4	2.5	2.5	2.5	2.4	2.6	2.6	2.5	2.5	2.5
PLAY	0	0	2.5	2.5	2.5	2.4	2.5	2.5	2.5	2.4	2.6	2.6	2.5	2.5	2.5
Pin No.	16	17	18	19	20	21	22	23	24	25	26	27	28	29	30
STOP	2.5	2.5	2.5	2.5	2.5	2.6	2.6	2.5	2.5	0	2.5	2.4	2.4	2.5	2.5
PLAY	2.5	2.5	2.5	2.5	2.5	2.5	2.5	2.5	2.5	0	2.5	2.4	2.5	Fluc	2.5
Pin No.	31	32	33	34	35	36	37	38	39	40	41	42	43	44	45
STOP	2.5	0	2.5	2.5	2.5	5.0	5.0	0	0	0	0	0	0	0	5.0
PLAY	Fluc	0	Fluc	2.5	2.5	5.0	0	0	0	4.2	0	0	0	0	5.0
Pin No.	46	47	48	49	50	51	52	53	54	55	56	57	58	59	60
STOP	5.0	0	0	4.2	0	0	0	2.6	2.4	2.4	5.0	2.6	2.6	Fluc	4.0
PLAY	0	0	0	4.2	0	0	Fluc	2.6	2.5	2.5	5.0	2.5	2.5	2.2	4.1
Pin No.	61	62	63	64	65	66	67	68	69	70	71	72	73	74	75
STOP	2.8	2.1	5.0	0	0	2.0	Fluc	1.6	1.3	1.2	0	1.3	1.6	5.0	0
PLAY	2.6	2.1	0	0	0	3.3	3.7	3.0	2.2	3.5	0	2.8	1.7	4.0	0
Pin No.	76	77	78	79	80										
STOP	5.0	5.0	1.6	1.6	1.6										
PLAY	4.0	5.0	1.7	1.7	1.7										

IC102 BA6398FP

(V)

Pin No.	1	2	3	4	5	6	7	8	9	10	11	12	13	14	15
STOP	4.2	4.2	2.5	2.5	8.0	5.0	0	0	2.5	0	4.1	0	0	8.4	0
PLAY	Fluc	Fluc	Fluc	2.5	7.8	5.0	5.0	0	0	2.5	4.1	4.2	0	8.4	0
Pin No.	16	17	18	19	20	21	22	23	24	25	26	27	28		
STOP	0	4.1	4.1	2.6	2.5	8.9	8.9	2.5	2.5	2.5	4.2	4.2	0		
PLAY	0	Fluc	Fluc	0	2.5	8.9	8.9	2.5	2.5	Fluc	Fluc	Fluc	0		

IC104 LC7867E

* With Emphasis : 5 V

(V)

Pin No.	1	2	3	4	5	6	7	8	9	10	11	12	13	14	15
STOP	0	2.3	2.3	2.7	0	2.3	2.3	2.6	0	0	0	5.0	0	2.5	4.2
PLAY	0	2.3	2.3	2.4	0	2.5	2.5	2.6	0	Fluc	0	0	0	2.5	4.2
Pin No.	16	17	18	19	20	21	22	23	24	25	26	27	28	29	30
STOP	4.2	0.5	1.8	0	5.0	5.0	0	0	5.0	0	0	0	0	0	5.0
PLAY	0	0.6	2.0	5.0	2.5	5.0	0	0	5.0	0	0	0	0	0	5.0
Pin No.	31	32	33	34	35	36	37	38	39	40	41	42	43	44	45
STOP	1.3	1.3	2.5	2.5	0	2.3	0	2.5	2.3	1.8	2.5	4.6	2.6	0	2.3
PLAY	1.3	1.3	2.5	2.5	1.7	2.3	0	2.5	2.4	Fluc	2.5	0	2.7	0	0
Pin No.	46	47	48	49	50	51	52	53	54	55	56	57	58	59	60
STOP	0	2.5	0	2.5	0	0	0	0	5.0	5.0	0	5.0	2.3	2.0	5.0
PLAY	0	2.5	0	2.5	0	0	0	0	5.0	5.0	0	0	2.3	2.0	5.0
Pin No.	61	62	63	64											
STOP	0	0	2.5	2.5											
PLAY	0	0	2.5	2.5											

IC105 SM5871AS

* With Emphasis : 0 V

(V)

Pin No.	1	2	3	4	5	6	7	8	9	10	11	12	13	14	15
STOP	2.6	0	0	2.7	5.0	5.0	0	2.5	2.3	0	5.0	0	5.0	5.0	0
PLAY	2.6	0	0	2.7	5.0	5.0	5.0	2.5	2.3	1.7	5.0	0	0	5.0	0
Pin No.	16	17	18	19	20	21	22	23	24	25	26	27	28		
STOP	5.0	5.0	2.5	0	2.5	5.0	5.0	2.5	0	2.5	5.0	5.0	2.6		
PLAY	5.0	5.0	2.5	0	2.5	5.0	5.0	2.5	0	2.5	5.0	5.0	2.6		

Fluc : Fluctuation

IC VOLTAGES

IC106 NJM2100

(V)

Pin No.	1	2	3	4	5	6	7	8							
STOP / PLAY	2.5	2.5	2.5	0	2.5	2.5	2.5	5.0							

IC111 CXP82432-107Q

(V)

Pin No.	1	2	3	4	5	6	7	8	9	10	11	12	13	14	15
STOP	0	5.0	5.0	5.0	0	4.6	0	5.0	0	5.0	5.0	0	5.0	0	0
PLAY	Fluc	5.0	5.0	5.0	0	4.6	0	5.0	0	5.0	5.0	0	5.0	Fluc	0
Pin No.	16	17	18	19	20	21	22	23	24	25	26	27	28	29	30
STOP	4.6	0	0.8	0	0.5	1.8	1.6	0	5.0	0	0	0	0	0	0
PLAY	4.6	0	0.8	0	0.5	1.4	0.8	0	5.0	0	0	0	0	0	0
Pin No.	31	32	33	34	35	36	37	38	39	40	41	42	43	44	45
STOP	0	5.0	5.0	5.0	0	0	5.0	5.0	2.3	2.7	0	5.0	0	5.0	5.0
PLAY	0	5.0	5.0	5.0	0	0	5.0	5.0	2.4	2.7	0	5.0	0	5.0	5.0
Pin No.	46	47	48	49	50	51	52	53	54	55	56	57	58	59	60
STOP	5.0	0	0	0	5.0	5.0	5.0	5.0	5.0	5.0	-1.8	-29	-29	-18	-1.2
PLAY	5.0	0	0	0	5.0	5.0	5.0	5.0	5.0	5.0	Fluc	Fluc	Fluc	Fluc	Fluc
Pin No.	61	62	63	64	65	66	67	68	69	70	71	72	73	74	75
STOP	-1.5	-22	-1.4	0	-29	-32	-29	-26	-1.1	-29	-1.6	-27	-27	-27	-27
PLAY	Fluc	Fluc	Fluc	Fluc	Fluc	Fluc	Fluc	Fluc	Fluc	Fluc	Fluc	Fluc	Fluc	Fluc	Fluc
Pin No.	76	77	78	79	80	81	82	83	84	85	86	87	88	89	90
STOP	-27	-27	-27	-27	-27	-27	-27	-27	-27	-27	-27	-27	-27	-32	5.0
PLAY	Fluc	Fluc	Fluc	Fluc	Fluc	Fluc	Fluc	Fluc	Fluc	Fluc	Fluc	Fluc	Fluc	Fluc	5.0
Pin No.	91	92	93	94	95	96	97	98	99	100					
STOP	0	5.0	0	0	4.7	5.0	5.0	0	0	0					
PLAY	0	5.0	0	0	0	5.0	5.0	0	0	Fluc	4.2				

IC112 LE24C04

(V)

Pin No.	1	2	3	4	5	6	7	8							
STOP / PLAY	0	0	0	0	5.0	5.0	0	5.0							

IC181 LB1648

(V)

Pin No.	1	2	3	4	5	6	7	8	9	10	11	12			
STOP / PLAY	9.0	5.0	0.5	0.5	5.0	2.8	9.0	5.0	0.5	0.5	5.0	3.0			

IC182 LB1648

(V)

Pin No.	1	2	3	4	5	6	7	8	9	10	11	12			
STOP / PLAY	9.0	0	0	0.5	5.0	2.1	9.0	5.0	0.5	0	0	3.0			

IC183 LB1648

(V)

Pin No.	1	2	3	4	5	6	7	8	9	10	11	12			
STOP / PLAY	9.0	5.0	0.5	0	0	0	9.0	0	0	0	0	3.0			

IC184 ML74HC14A

(V)

Pin No.	1	2	3	4	5	6	7	8	9	10	11	12	13	14	
STOP / PLAY	5.0	0	5.0	0	5.0	0	0	0	5.0	0	5.0	0	5.0	5.0	

IC185 ML74HC14A

(V)

Pin No.	1	2	3	4	5	6	7	8	9	10	11	12	13	14	
STOP / PLAY	0	5.0	0	5.0	0	5.0	0	5.0	0	0	5.0	5.0	0	5.0	

Fluc : Fluctuation

