

Service Manual

THE FISHER®

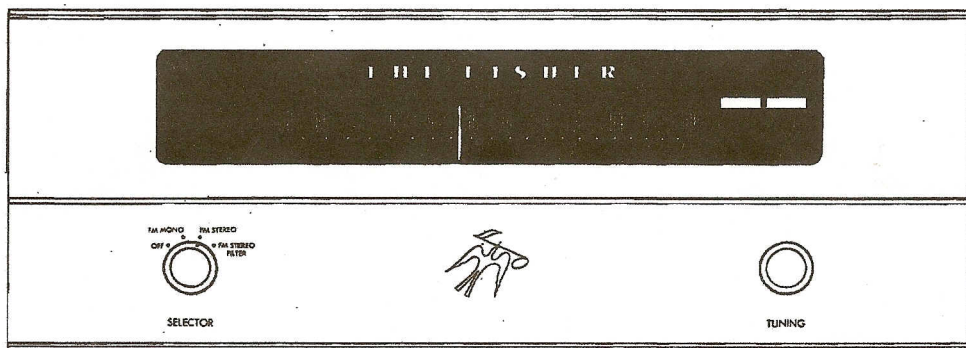
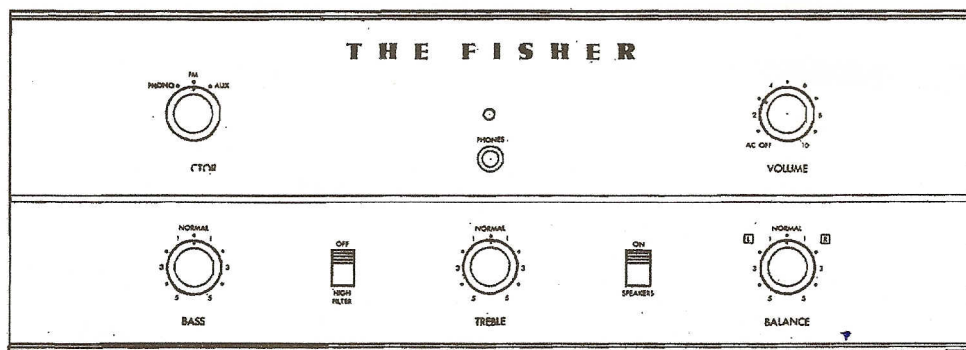

FM-190

TUNER

X-190

AMPLIFIER

CAUTION: This is a FISHER precision high-fidelity instrument. It should be serviced only by qualified personnel — trained in the repair of transistor equipment and printed circuitry.

EQUIPMENT AND TOOLS NEEDED

The following are needed to completely test and align modern high-fidelity instruments such as amplifiers, tuners and receivers.

Test Instruments

Vacuum-Tube Voltohmmeter DC VTVM
Audio (AC) Vacuum-Tube Voltmeter (AC VTVM)
Oscilloscope (Flat to 100 kc minimum)
Audio (Sine-wave) Generator
Intermodulation Analyzer
Sweep (FM) Generator (88 to 108 mc)
Marker Generator
Multiplex Generator (preferably with RF output—
FISHER Model 300 or equal).

Miscellaneous

Adjustable-Line-Voltage Transformer or
line-voltage regulator
Load Resistors (2) — 8-ohm, 50-watt (or higher)
Stereo source (Turntable with stereo cartridge
or Tape Deck)
Speakers (2) Full-range, for listening tests
Soldering iron (with small-diameter tip).
Fully insulated from power line.

PRECAUTIONS

Many of the items below are included just as a reminder—they are normal procedures for experienced technicians. Shortcuts can be taken but often they cause additional damage—to transistors, circuit components or the printed-circuit board.

Soldering—A well-tinned, hot, clean soldering iron tip will make it easier to solder without damage to the printed-circuit board or the many many circuit components mounted on it. It is not the wattage of the iron that counts—it is the heat available at the tip. Low-wattage soldering irons will often take too long to heat a connection—pigtail leads will get too hot and damage the part. Too much heat, applied too long, will damage the printed-circuit board. Some 50-watt irons reach temperatures of 1,000° F—others will hardly melt solder. Small-diameter tips should be used for single solder connections—larger pyramid and chisel tips are needed for larger areas.

- When removing defective resistors, capacitors, etc., the leads should be cut as close to the body of the circuit component as possible. (If the part is not being returned for in-warranty factory replacement it may be cut in half—with diagonal-cutting pliers—to make removal easier.)

- Special de-soldering tipleths are made for unsoldering multiple-terminal units like IF transformers and electrolytic capacitors. By unsoldering all terminals at the same time the part can be removed with little chance of breaking the printed-circuit board.

- Always disconnect the chassis from the power line when soldering. Turning the power switch OFF is not enough. Power-line leakage paths, through the heating element, can destroy transistors.

Transistors—Never attempt to do any work on the transistor amplifiers without first disconnecting the AC-power linecord—wait until the power supply filter-capacitors have discharged.

- Guard against shorts—it takes only an instant for a base-to-collector short to destroy that transistor and possibly others direct-coupled to it. [In the time it takes for a dropped machine screw, washer or even the screwdriver, to glance off a pair of socket terminals (or between a terminal and the chassis) a transistor can be ruined.]

- DO NOT bias the base of any transistor to, or near, the same voltage applied to its collector.

- DO NOT use an ohmmeter for testing transistors. The voltage applied through the test probes may be higher than the base-emitter breakdown voltage of the transistor.

Output Stage and Driver—Replacements for output and driver transistors, if necessary, must be made from the same beta group as the original type. The beta group is indicated by a colored dot on the mounting flange of the transistor. Be sure to include this information, when ordering replacement transistors.

- If one output transistor burns out (open or shorts), always remove all output transistors in that channel and check the bias adjustment, the control and other parts in the network with an ohmmeter before inserting a new transistor. All output transistors in one channel will be destroyed if the base-biasing circuit is open on the emitter end.

- When mounting a replacement power transistor be sure the bottom of the flange, the mica insulator and the surface of the heat sink are free of foreign matter. Dust and grit can prevent perfect contact. This reduces heat transfer to the heat sink. Metallic particles can puncture the insulator and cause shorts—ruining the transistor.

- Silicone grease must be used between the transistor and the mica insulator and between the mica and the heat sink for best heat conduction. Heat is the greatest enemy of electronic equipment. It can shorten the life of transistors, capacitors and resistors. (Use Dow-Corning DC-3 or C20194 or equivalent compounds made for power transistor heat conduction.)

- Use care when making connections to speakers and output terminals. Any frayed wire ends can cause shorts that may burn out the output transistors—they are direct-coupled to the speakers. There is no output transformer—nothing to limit current through the transistors except the fuses. To reduce the possibility of shorts at the speakers, lugs should be used on the exposed ends—at least the ends of the stranded wires should be tinned to prevent frayed wire ends. The current in the speakers and output circuitry is quite high. Any poor contact or small-size wire, can cause power losses in the speaker system. Use 14 or 16 AWG for long runs of speaker-connecting wiring.

DC-Voltage Measurements—These basic tests of the transistor circuitry are made without the signal generator. Without any signal input measure the circuit voltages—as indicated on the schematic. The voltage difference between the base and the emitter should be in the millivolt range—a sensitive DC meter is needed for these readings. A low-voltage range of 1 volt, full scale—or lower—is needed.

Audio-Voltage (gain) Measurements—The schematic and printed-circuit board layout diagrams are used. Input signals are injected at the proper points—found most quickly by using layout of the printed-circuit board instead of the schematic. An AUDIO (AC) VTVM connected to the test points should indicate voltages close to those values shown in the boxes on the schematic. Many of the signal levels in the input stages are only a few millivolts—they can not be read on the AC ranges supplied on most Vacuum-Tube AC/DC Volt-ohmmeters (VTVMs). Even with a 1-volt range a signal level of 100 millivolts (.1 volt) will be the first 1/10 of the meter scale. A reading of 1 millivolt (.001 volt) will hardly even move the meter needle.

DIAL STRINGING PROCEDURE

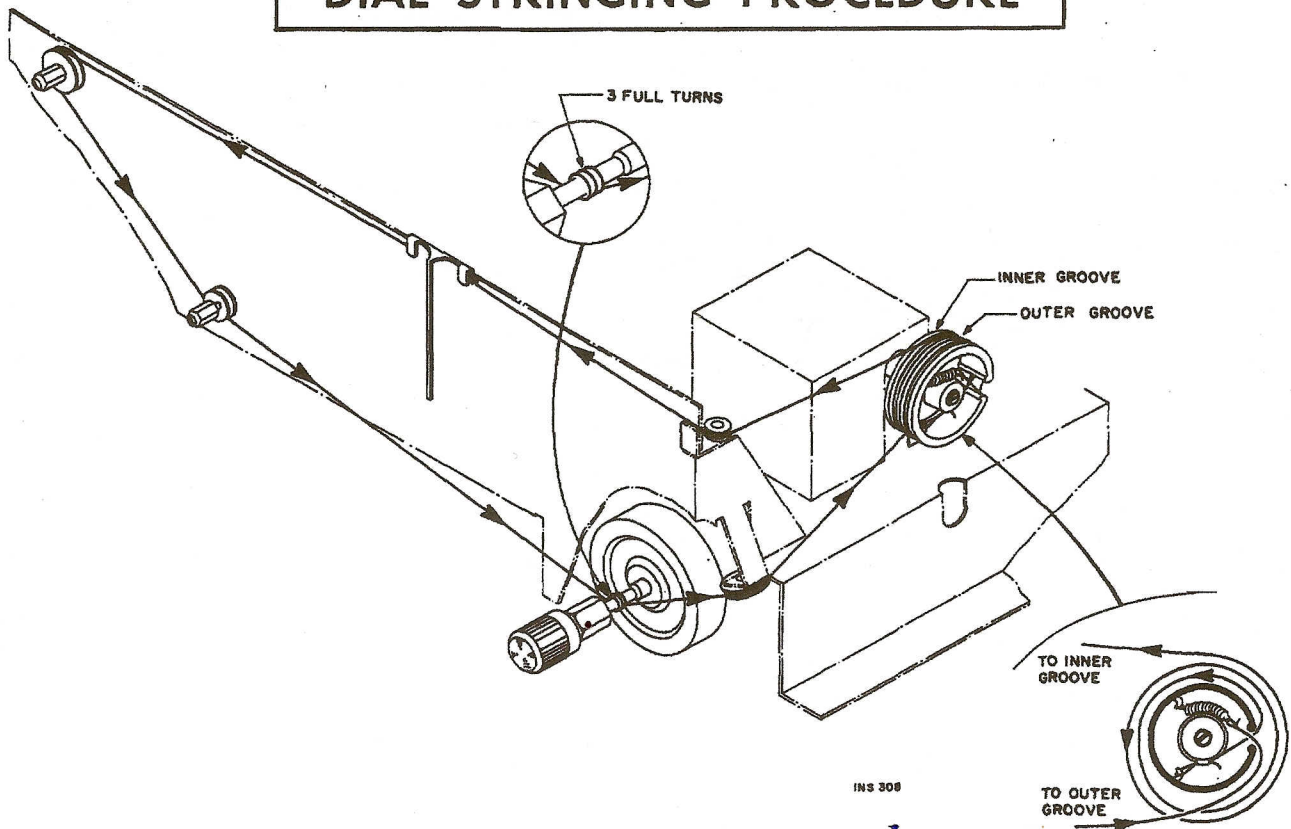

● Hook one end of the spring over the bottom ear in the front-end drive-drum (with the drum rotated to its extreme counterclockwise position).

● Stretch the tension spring until the loop on the free end sticks out of the slot in the edge of the drive-drum. Now insert a length of stiff wire, about 1-inch long (a piece of straightened-out paper clip will do nicely) through the loop to keep the spring stretched while stringing the dial cord. Place the piece of stiff wire in the outer groove of the drive-drum; bridging the slot in the drive-drum.

● Tie a small, non-slip, loop in the end of the dial cord.

● Thread the loop in the dial cord through the opening in the drive-drum slot, under the spring, and hook the loop over the top ear inside the drive drum.

● Wrap the dial cord around the drive-drum (counterclockwise) about $\frac{3}{4}$ of a turn, in the inner groove, and then around the top guide pulley.

● Stretch the dial cord to the left end of the dial, around the two guide pulleys and then back to the fly-wheel drive shaft.

● Wind 3 full turns of dial cord around the drive shaft (as shown in the upper detail drawing).

● While keeping the dial cord taut rotate the drive-drum to

its extreme clockwise position and fit the dial cord into the remaining pulley.

● Set the dial cord in the outer groove of the front-end drive-drum and thread it through the loop in the end of the tension spring. (See detail drawing at lower right.)

● Pull all slack dial cord through the loop in the tension spring.

● Check all pulleys for proper threading of the dial cord.

● Tie a small knot in the dial cord to secure it to the loop in the tension spring. (Use a tweezer with a small tip to help tie the knot.) Keep dial cord as taut as possible while tying the knot.

● Apply a drop of quick-drying cement to the knot to prevent it from slipping or becoming undone.

● After the cement has dried completely pull out the piece of stiff wire and gently let the spring contract to apply tension to the dial cord.

● Rotate the front-end drive-drum to its extreme counterclockwise position.

● Set the dial pointer to the zero (0) calibration on the logging scale of the slide-rule dial.

● Attach the pointer to the dial cord and cement it in place with a drop or two of quick-drying cement.

If replacement parts are out of stock, locally, they may be obtained directly from the Parts Department of FISHER Radio Corporation. They will be shipped "best way", either prepaid or C.O.D. unless otherwise specified.

For instrument-operation information and technical assistance write Richard Hamilton, Customer Service Department, FISHER Radio Corporation, Long Island City, New York 11101.

TROUBLESHOOTING GUIDE

When a defect occurs in an electronic circuit the first component suspected is usually the vacuum tube. Many of the inexpensive tube testers will not indicate all the possible internal faults in a vacuum tube - slight defects often sneak past these testers. It is better to substitute another tube of the same type.

Sometimes it is possible to switch (transpose) tubes from one circuit to another. This method of testing is most suitable when testing an individual stereo channel. When a good tube is switched with a defective one of the same type the symptom will be transferred from one stereo channel to the other.

When substituting tubes it is absolutely necessary to be certain the tube being inserted is good - a new tube, from a freshly opened carton, is not necessarily a perfect tube. Defects can occur from shipping and handling.

If you have any doubts about the quality of a tube try it in an identical circuit that is operating properly. For example, a tube with heater-cathode leakage may operate normally in a circuit with its cathode grounded; transpose (switch) it with one in a circuit that has a cathode-bias resistor and it will cause a lot of hum.

Does not go on - (pilot or dial lamps do not light) in any position of the SELECTOR switch.

- Check:
- AC-interlock plug and socket, power cord and plug, wall outlet.
 - Automatic shut-off switch S1 (part of SELECTOR switch)
 - Power switch S4.

Does not go on - (pilot or dial lamps do not light) only in PHONO positions of the SELECTOR switch.

- Check:
- Automatic shut-off switch S1 (part of SELECTOR switch).
 - J9 and its plug and the interconnecting cable and the turntable switch on the record player.

Distortion (Both channels) in any position of the SELECTOR switch.

Hum, Weak or
No audio output

- Check:
- SPKR switch position and its operation.
- Test or substitute V1. Test for proper DC voltages at: CR2, C2, R3; R3, R6, C3B; R6, R7, C3C; R7, C3D.

Hum - in any position of the SELECTOR switch.

- Check:
- Setting of HUM ADJUST CONTROL (R2).
 - 295-volt DC power supply filter (C3A, B, C, D).
 - Bias supply (CR3 and C4) for AC ripple.

Distortion (LEFT channel only) SELECTOR in PHONO and FM positions.

Hum, Weak or
No audio output

- Check:
- Remove plug from LEFT RCRDR OUT jack, if used.
- Test (filament leakage for hum) or substitute V1, V4, V5.

Hum or (RIGHT channel only) SELECTOR in PHONO and FM positions.

No audio output

- Check:
- Remove plug from RIGHT RCRDR OUT jack, if used.
- Test (filament leakage for hum) or substitute V1, V4, V5.

Hum or SELECTOR in PHONO positions only

No audio output

- Check:
- J3, J7, J9 and their plugs and interconnecting cables to the record player.
 - Clean and tighten all ground connections.
 - Reverse AC line-cord plug in wall outlet
 - Reverse AC line-cord plug from record player in J18 (on chassis) if used.

Hum or SELECTOR in FM position only.

No audio output

- Check:
- Try other stations
 - Reverse AC line-cord plug in wall outlet.

- Check:
- Antenna connections and antenna (outdoor)
- Test (filament leakage for hum) or substitute V11, V12, V13, V14.

Hum- SELECTOR in FM STEREO position only

No audio output

Distortion

- Check:
- Balanced modulator D401 and C409, C410; C407, C412; L401, L402.
- Test (filament leakage for hum) or substitute V401, V402.

STEREOSCAN indicator inoperative

- Check:
- I5, V402, C406, R433, R434, R435, CR402, CR401.
 - Alignment of Z421.

1131-2 MULTIPLEX • PRINTED CIRCUIT

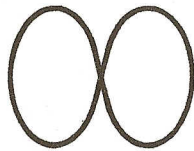

FIGURE 1. Lissajous pattern for MPX Oscillator alignment.

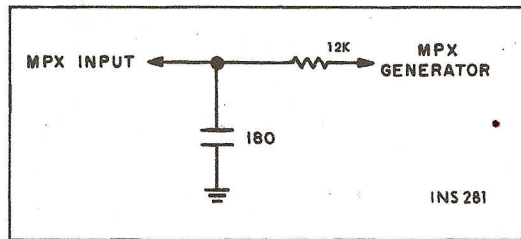
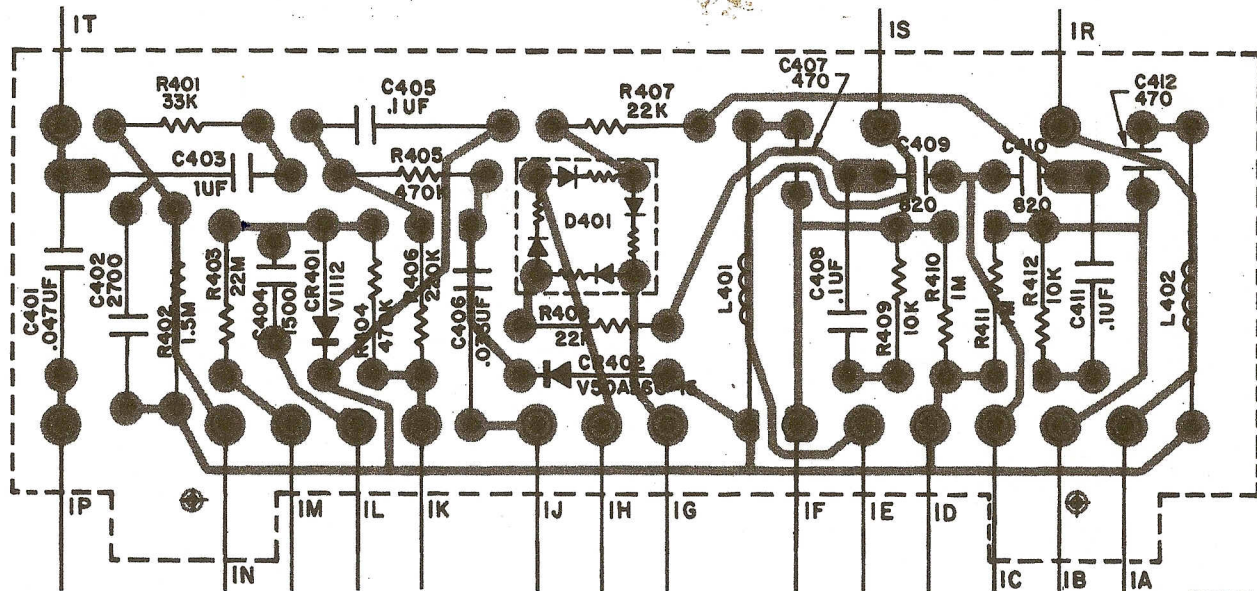

FIGURE 2. Multiplex-alignment coupling network circuit.



INS256

ALIGNMENT INSTRUCTIONS • MULTIPLEX SECTION

GENERAL

The preferred alignment procedure, in table 1 below, uses a multiplex generator with an RF output, like the FISHER Model 300. Optimum performance will be obtained only when the multiplex decoder is connected to the FM detector with which it will be used. Check IF alignment first—poor alignment can prevent proper multiplex decoder operation.

TEST EQUIPMENT REQUIRED: MULTIPLEX GENERATOR, AUDIO (AC) VTVM, 100 KC OSCILLOSCOPE WITH EXTERNAL SWEEP JACKS, ALIGNMENT TOOL.

TABLE 1

STEPS	GENERATOR			INDICATOR TYPE AND CONNECTION	ADJUST	ALIGNMENT INDICATION
	CONNECTION	MODULATION	RF DEVIATION			
1	Multiplex generator RF output to antenna terminals	19 kc pilot only	±7.5 kc	VTVM to TP 421	Z1 top and bottom	Maximum reading on VTVM
2	19 kc output of generator to oscilloscope horizontal input; generator not connected to MPX section	—	—	Vertical input of oscilloscope to 422; set oscilloscope for external sweep	Z2	Set frequency of free-running oscillator as close as possible to 38 kc. Lissajous pattern (see figure 1) should be as slow-moving as possible.
3	Same as Step 1	Composite MPX; 1000 cps on left channel only	±75 kc	VTVM and oscilloscope vertical input to right channel output lug (terminal 1R)	Z1 top	Maximum reading on VTVM; clean 1000 cps sine wave on oscilloscope
4	Same as Step 1	Composite MPX; 1000 cps on right channel only	±75 kc	Same as Step 3	MPX separation control (R4)*	Minimum reading on VTVM should be at least 33 db below reading obtained in Step 3.
5	Same as Step 1	Same as Step 4	±75 kc	VTVM and oscilloscope vertical input to right channel output lug (terminal 1S)	—	Same VTVM reading as obtained in Step 3 ± 2 db; clean 1000 cps sine wave on oscilloscope
6	Same as Step 1	Composite MPX; 1000 cps on left channel only	±75 kc	Same as Step 5	MPX separation control (R4), if necessary*	Minimum reading on VTVM should be at least 33 db below reading obtained in Step 5.

* If adjustment is required, adjust for best compromise readings in Steps 4 and 6.

ALTERNATE ALIGNMENT PROCEDURE For multiplex generators without an RF output

When using this alignment procedure, it is necessary to disconnect the ratio detector from the multiplex decoder at the point where the generator is connected. Unsolder point IT carefully. The generator input must be through a simple low-pass filter—a 12 K resistor between the multiplex generator and the MPX input with a 180 pF capacitor from the MPX input end of the resistor to ground (Figure 2, on schematic).

TEST EQUIPMENT REQUIRED: MULTIPLEX GENERATOR, AUDIO (AC) VTVM, 100 KC OSCILLOSCOPE WITH EXTERNAL SWEEP JACKS, ALIGNMENT TOOL.

TABLE 2

STEPS	GENERATOR			INDICATOR TYPE AND CONNECTION	ADJUST	ALIGNMENT INDICATION
	CONNECTION	AUDIO	LEVEL			
1	Composite output of MPX generator to input of MPX demodulator (Point 1)	19 kc pilot only	100 mV RMS (260 MV P-P)	AC VTVM to TP 421	Z1 top and bottom	Maximum reading on VTVM
2	19 kc output of generator to oscilloscope horizontal input; generator not connected to MPX section	—	—	Oscilloscope vertical input to TP 422	Z2	Set frequency of free-running oscillator as close as possible to 38 kc. Lissajous pattern (see figure 1) should be as slow-moving as possible.
3	Same as Step 1	1000 cps on left channel only	0.7 V RMS (3.92 V P-P)	AC VTVM and oscilloscope vertical input to left channel output lug (terminal 1R)	Z1 top	Maximum reading on VTVM; clean 1000 cps sine wave on oscilloscope
4	Same as Step 1	1000 cps on right channel only	0.7 V RMS (3.92 V P-P)	Same as Step 3	MPX separation control (R4)*	Minimum reading on VTVM should be at least 33 db below reading obtained in Step 3.
5	Same as Step 1	Same as Step 4	0.7 V RMS (3.92 V P-P)	VTVM and oscilloscope vertical input to right channel output lug (terminal 1S)	—	Same VTVM reading as obtained in Step 3 ± 2 db; clean 1000 cps sine wave on oscilloscope
6	Same as Step 1	1000 cps on left channel only	0.7 V RMS (3.92 V P-P)	Same as Step 5	MPX separation control (R4), if necessary*	Minimum reading on VTVM should be at least 33 db below reading obtained in Step 5.

* If adjustment is required, adjust for best compromise readings in Steps 4 and 6.

TUNER • SCHEMATIC

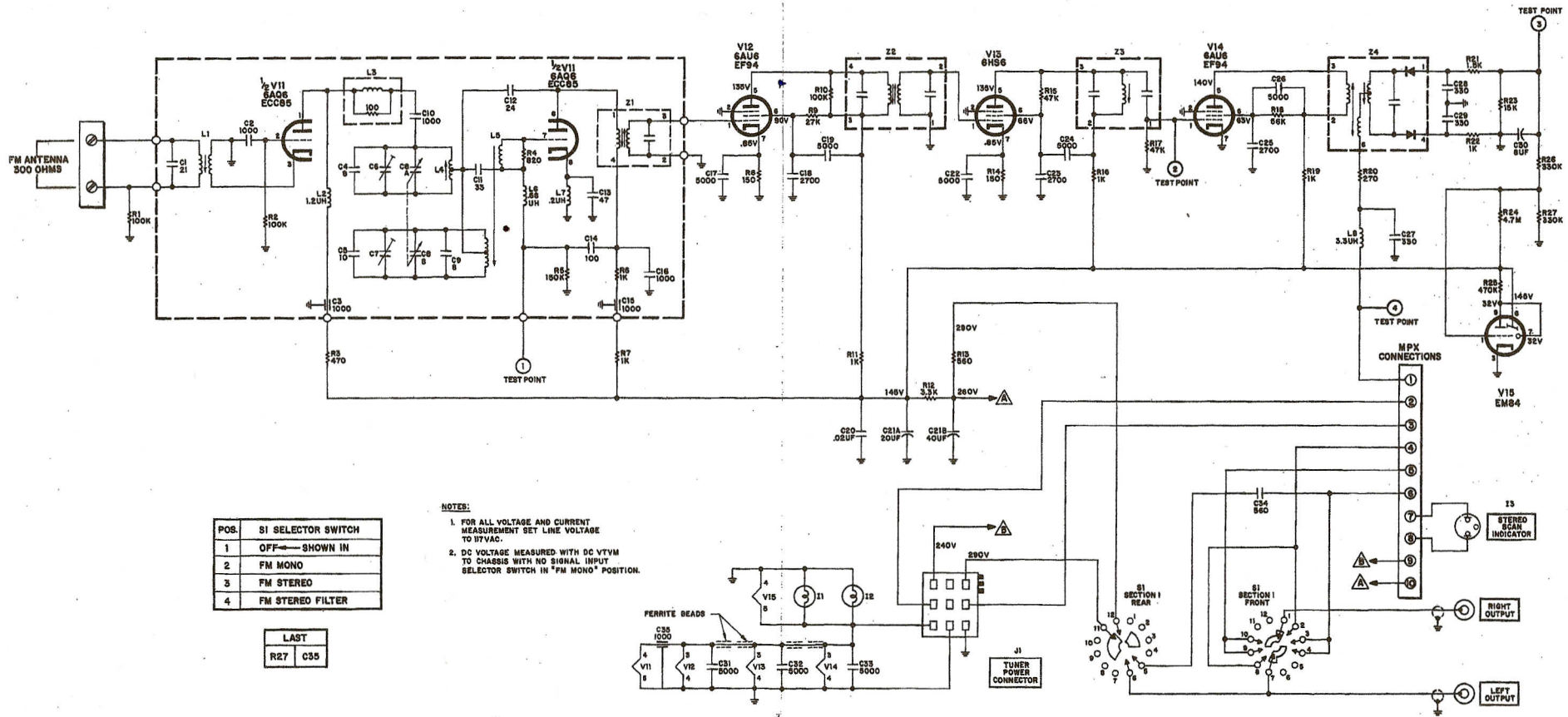

POS.	S1 SELECTOR SWITCH
1	OFF — SHOWN IN
2	FM MONO
3	FM STEREO
4	FM STEREO FILTER

LAST
R27 C35

NOTES:

1. FOR ALL VOLTAGE AND CURRENT MEASUREMENT SET LINE VOLTAGE TO 117VAC.
2. DC VOLTAGE MEASURED WITH DC VTVM TO CHASSIS WITH NO SIGNAL INPUT SELECTOR SWITCH IN "FM MONO" POSITION.

AMPLIFIER • PARTS DESCRIPTION LIST

CAPACITORS

10% tolerance for all fixed capacitors, unless otherwise noted or marked GMV (guaranteed minimum value). All capacitors not marked uF are pF (uuF).

Symbol	Description	Part No.	Symbol	Description	Part No.
C1	Molded, .01uF, 20%, 600V	C2747	C4	Electrolytic, 8uF, 50V	C629-138
C2	Electrolytic, 100uF, 250V	C50180-15	C5	Mylar, .047uF, 250V	C50197-52
C3	Electrolytic, 4-Section	C50180-58	C6, 7	Ceramic, 33, N750, 1000V	C50870-15
	A- 100uF, 250V		C8, 9	Ceramic, 3900, 1000V	C50072-34
	B- 40uF, 350V		C10, 11	Ceramic, 2200, 1000V	C50072-5
	C- 200uF, 350V		C12, 13	Ceramic, 1800, 1000V	C50072-8
	D- 20uF, 350V		C14, 15	Ceramic, 68, N2200, 1000V	C50070-12
			C16, 17	Ceramic, .02uF, 20%, 500V	C50089-5
			C18, 19	Ceramic, 39, N1500, 1000V	C50070-17
			C20, 21	Mylar, .022uF, 400V	C50197-28
			C22, 23	Mylar, .022uF, 250V	C50197-49
			C24	Molded, .01uF, 20%, 600V	C2747

RESISTORS

In ohms, 5% tolerance, 1/3 W unless otherwise noted. K=Kilohms, M=Megohms.

Symbol	Description	Part No.	Symbol	Description	Part No.
R1	Composition, 820K, 10%, 1/2W	RC20BF824K	R20	Pot., 500K, Balance Control	R50160-137
R2	Pot., Wirewound, 500, Hum Adj.	R516-128	R21A, B	Pot., 500K, Dual, Volume Control	R50160-139
R3	Composition, 1.8K, 10%, 1W	RC30BF152K	R22, 23	Dep. Carbon, 22K	R33DC223J
R4	Composition, 270K, 1/2W	RC20BF274J	R24, 25	Dep. Carbon, 47K	R33DC473J
R5	Composition, 470K, 1/2W	RC20BF474J	R26, 27	Dep. Carbon, 390K	R33DC394J
R6	Composition, 1.8K, 10%, 1/2W	RC20BF182K	R28, 29	Dep. Carbon, 1K	R33DC102J
R7	Composition, 3.3K, 10%, 1/2W	RC20BF332K	R30, 31	Dep. Carbon, 220	R33DC221J
R8, 9	Dep. Carbon, 820K	R33DC824J	R32, 33	Dep. Carbon, 47K	R33DC474J
R10, 11	Dep. Carbon, 8.2M	R33DC825J	R34, 35	Composition, 150K, 10%, 1/2W	RC20BF154K
R12, 13	Composition, 18M, 10%, 1/2W	RC20BF186K	R36A, B	Pot., 100K, Dual, AC Balance	R1078-116
R14, 15	Dep. Carbon, 1K	R33DC102J	R37, 38		
R16, 17	Dep. Carbon, 100K	R33DC104J	39, 40	Dep. Carbon, 1M	R33DC105J
R18A, B, 19A, B	Pot., 500K, Dual, Bass, Treble	R50160-138	R41, 42		
			43, 44	Dep. Carbon, 1K	R33DC102J
			R45, 46	Dep. Carbon, 6.8K	R33DC682J
			R47, 48	Composition, 100, 10%, 1W	RC30BF101K
			R49, 50	Wirewound, 50, 10%, 5W	R556-142

MISCELLANEOUS

Symbol	Description	Part No.	Symbol	Description	Part No.
CR1, 2	Diode, Silicon Rectifier	SR50472	PC1, 2	Printed Circuit, Tone Control	PC50187-9
CR3	Diode, Silicon Rectifier	V-1112	S1	Switch, Selector	S1078-112
I1	Pilot Bulb, #1847	150009-7	S2, 3	Switch, Slide	S50200-5
J11	Phone Jack	J846-120-1	T1	Transformer, Power	T1078-115
			T2	Transformer, Output	T1078-117-2
			T3	Transformer, Output	T1078-117-1

If replacement parts are out of stock, locally, they may be obtained directly from the Parts Department of FISHER Radio Corporation. They will be shipped "best way", either prepaid or C.O.D. unless otherwise specified.

For instrument-operation information and technical assistance write Richard Hamilton, Customer Service Department, FISHER Radio Corporation, Long Island City, New York 11101.

FM TUNER • PARTS DESCRIPTION LIST

CAPACITORS

10% tolerance for all fixed capacitors, unless otherwise noted or marked GMV (guaranteed minimum value). All capacitors not marked uF are pF (uuF).

Symbol	Description	Part No.	Symbol	Description	Part No.
C1	Ceramic, 21, 5%, N750, 1000V	C50070-32	C17	Ceramic, 5000, +80 -20%, 500V	C50089-6
C2	Ceramic, 1000, GMV, 1000V	C50071-2	C18	Ceramic, 2700, 1000V	C50072-17
C3	Ceramic, Feedthru, 1000 GMV	C592-187	C19	Ceramic, 5000, +80 -20%, 500V	C50089-6
C4	Ceramic, 8, ±.5pF, NPO, 500V	CC20CJ080D5	C20	Ceramic, .02uF, GMV, 1000V	C50071-6
C5	Ceramic, 10, ±.5pF, N150, 500V	CC20PJ100D5	C21	Electrolytic, 2-Section	C50180-76
C6, 7	Ceramic, Trimmer	C662-123		A- 40uF, 350V	
C8A, B	Variable, FM	C818-116		B- 20uF, 350V	
C9	Ceramic, 8, ±.5pF, NPO, 500V	CC20CJ080D5	C22	Ceramic, 5000, +80 -20%, 500V	C50089-6
C10	Ceramic, 1000, GMV, 1000V	C50071-2	C23	Ceramic, 2700, 1000V	C50072-17
C11	Ceramic, 33, 5%, N750, 1000V	C50070-25	C24	Ceramic, 5000, +80 -20%, 500V	C50089-6
C12	Ceramic, 24, 5%, N150, 1000V	C50070-8	C25	Ceramic, 2700, 1000V	C50072-17
C13	Ceramic, 47, 5%, N750, 1000V	C50070-29	C26	Ceramic, 5000, +80 -20%, 500V	C50089-6
C14	Ceramic, 100, 5%, N1500, 1000V	C50070-19	C27, 28		
C15	Ceramic, Feedthru, 1000, GMV	C592-187	29	Ceramic, 330, 1000V	C50072-1
C16	Ceramic, 1000, 1000V	C50072-3	C30	Electrolytic, 8uF, 50V	C629-138
			C31, 32		
			33	Ceramic, 5000, +80 -20%, 500V	C50089-6
			C34	Ceramic, 560, 1000V	C50072-14
			C35	Ceramic, 5000, +80 -20%, 500V	C50089-6

RESISTORS AND POTENTIOMETERS

Composition, in ohms, 10% tolerance, 1/2 Watt, unless otherwise noted. K=Kilohm, M=Megohm.

Symbol	Description	Part No.	Symbol	Description	Part No.
R1, 2	100K	RC20BF104K	R13	Glass, 560, 10%, 3W	RPG3W561K
R3	470	RC20BF471K	R14	150	RC20BF151K
R4	820	RC20BF821K	R15	47K	RC20BF473K
R5	150K	RC20BF154K	R16	1K	RC20BF102K
R6, 7	1K	RC20BF102K	R17	47K	RC20BF473K
R8	150	RC20BF151K	R18	56K	RC20BF563K
R9	27K	RC20BF273K	R19	1K	RC20BF102K
R10	100K	RC20BF104K	R20	270	RC20BF271K
R11	1K	RC20BF102K	R21	1.5K	RC20BF152K
R12	Glass, 3.3K, 10%, 7W	RPG7W332K	R22	1K	RC20BF102K
			R23	15K	RC20BF153K
			R24	4.7M	RC20BF475K
			R25	Dep. Carbon, 470K, 5%, 1/8W	R12DC474J
			R26, 27	Dep. Carbon, 330K, 5%, 1/8W	R12DC334J

MISCELLANEOUS

Symbol	Description	Part No.	Symbol	Description	Part No.
I1, 2	Lamp #1847	150009-7	L6	Choke, .68 Microhenry	L50066-1
I3	Stereo Scan Indicator	1508621-2	L7	Choke, .2 Microhenry	L50066-21
L1	Coil, FM Antenna	L818-113	L8	Choke, 3.3 Microhenry	L50066-8
L2	Choke 1.5 Microhenry	L50066-4	S1	Switch, Selector	S1194A-113
L3	Choke, RF	L629-180	Z1	Transformer, FM IF	ZZ662-117
L4	Coil, FM RF	L818-114	Z2	Transformer, FM IF	ZZ2987
L5	Coil, FM Oscillator	A5818-118	Z3	Coil, Limiter	ZZ50210-4
			Z4	Transformer, Ratio Detector	ZZ50210-9

1131-2 MULTIPLEX • SCHEMATIC

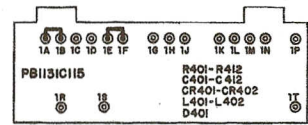
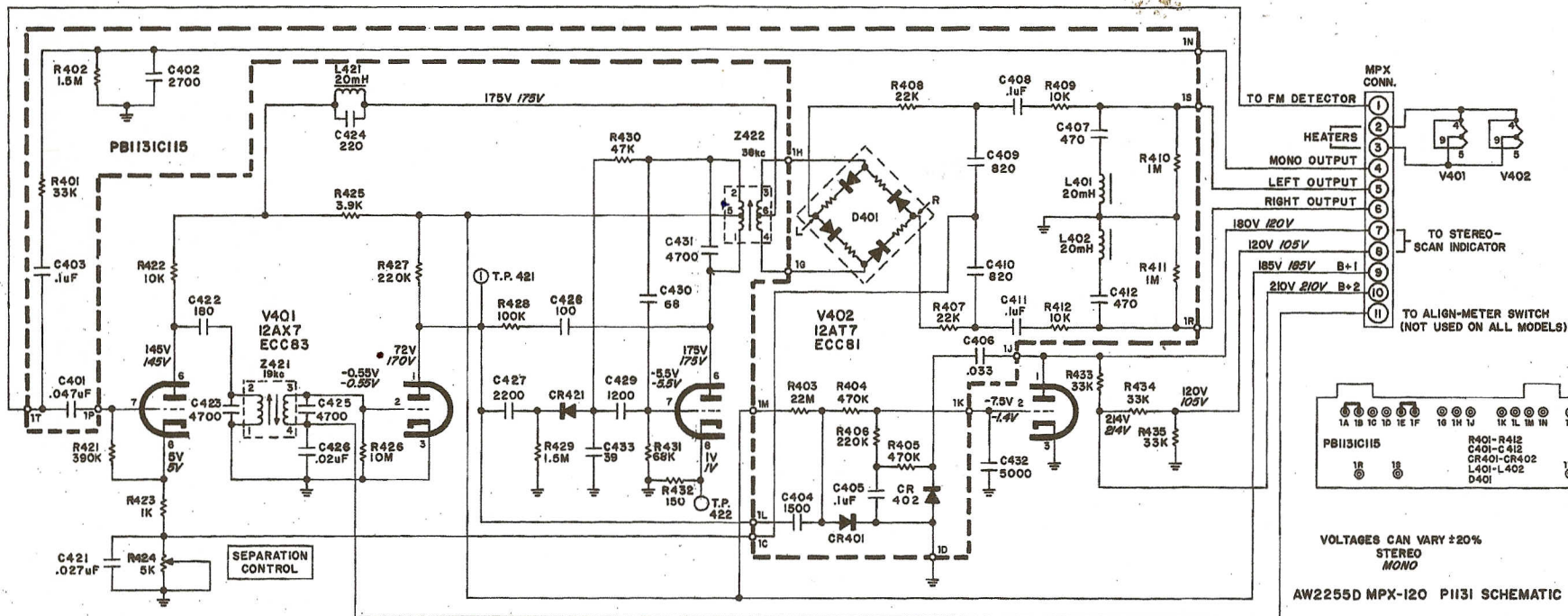

VOLTAGES CAN VARY ±20%
STEREO
MONO
AW2255D MPX-120 P1131 SCHEMATIC

PARTS DESCRIPTION LIST

All circuit components with symbols beginning with 401 are located on the printed-circuit board; those beginning with 421 are mounted on the metal subchassis.

CAPACITORS

20% tolerance for all fixed capacitors, unless otherwise noted or marked GMV (guaranteed minimum value). All capacitors not marked uF are pF (uF).

Symbol	Description	Part No.
C401	Capacitor, Mylar, .047uF 10% 100V	C50B574-5
C402	Capacitor, Polystyrene, 2700 5% 125V	C50B634-20
C403	Capacitor, Plastic Film, .1uF 20% 250V	C50B633-1
C404	Capacitor, Cer. Disc., 1500, 10% 250V	C50B576-4
C405	Capacitor, Plastic Film, 1uF 20% 250V	C50B633-1
C406	Capacitor, Plastic Film, .033uF 20% 400V	C50B633-20
C407	Capacitor, Cer. Disc., 470 pF 10%	C50B576-1
C408	Capacitor, Plastic Film, 1uF 20% 250V	C50B633-1
C409	Capacitor, Cer. Disc., 820 10%	C50B576-3
C410	Capacitor, Cer. Disc., 820 10%	C50B576-3
C411	Capacitor, Plastic Film, .1uF 20% 250V	C50B633-1
C412	Capacitor, Cer. Disc., 470 pF, 10%	C50B576-1
C421	Myler, .027 uF, 5%, 100V	C50B574-6
C422	Polystyrene, 180, 5%, 500V	C50B634-1

RESISTORS

Symbol	Description	Part No.
R401	Resistor, Dep. Carbon, 33k 5%, 1/8W	R12DC333J
R402	Resistor, Dep. Carbon, 1.5M, 5%, 1/3W	R33DC155J
R403	Resistor, Composition, 22M, 10%, 1/2W	RC20BF226K
R404	Resistor, Dep. Carbon, 470k, 5%, 1/8W	R12DC474J
R405	Resistor, Dep. Carbon, 470k, 5%, 1/8W	R12DC474J
R406	Resistor, Dep. Carbon, 470k, 5%, 1/8W	R12DC224J
R407	Resistor, Dep. Carbon, 22k, 5%, 1/8W	R12DC223J
R408	Resistor, Dep. Carbon, 22k, 5%, 1/8W	R12DC223J
R409	Resistor, Dep. Carbon, 10k, 5%, 1/8W	R12DC103J
R410	Resistor, Dep. Carbon, 1M, 5%, 1/8W	R12DC105J

Symbol	Description	Part No.
R411	Resistor, Dep. Carbon, 1M, 5%, 1/8W	R12DC105J
R412	Resistor, Dep. Carbon, 10k, 5%, 1/8W	R12DC103J
R421	Dep. Carbon, 2.2M, 5%, 1/3W	R33DC225J
R422	Dep. Carbon, 10k, 5%, 1/3W	R33DC103J
R423	Dep. Carbon, 1k, 5%, 1/3W	R33DC102J
R424	Potentiometer, 5K Separation Control	R50150-11
R425	Dep. Carbon, 3.9k, 5%, 1/3W	R33DC392J
R426	Composition, 10M, 10%, 1/2W	RC20BF106K
R427	Dep. Carbon, 220k, 5%, 1/3W	R33DC224J
R428	Dep. Carbon, 100k	R12DC104J
R429	Dep. Carbon, 1.5M, 5%, 1/3W	R33DC135J
R430	Dep. Carbon, 47k, 5%, 1/3W	R33DC473J
R431	Dep. Carbon, 68k	R12DC683J
R432	Dep. Carbon, 150, 5%, 1/3W	R33DC151J
R433, 434, 435	Composition, 33k, 10%, 1W	RC30BF333K

MISCELLANEOUS

Symbol	Description	Part No.
CR401	Diode	V1111W
CR402	Diode	V50A260-15
CR421	Diode	V1112
D401	Ring Demodulator	V50A260-18
L401	Coil	L50334-2
L402	Coil	L50334-2
L421	Coil, 20 uH	L50334-2
Z421	Transformer, 19 kc	ZZ50210-34
Z422	Transformer, 38 kc	ZZ50210-54
-	Printed Circuit Bd.	PB1131B111
-	Mini. Pin Term.	A50A577
-	Sleeving 23-32" Lg.	E50A684-4

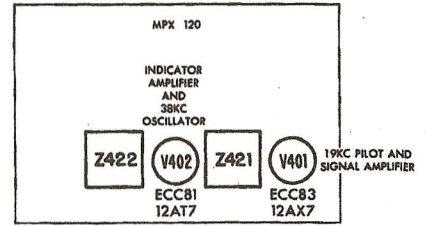

AMPLIFIER • SCHEMATIC

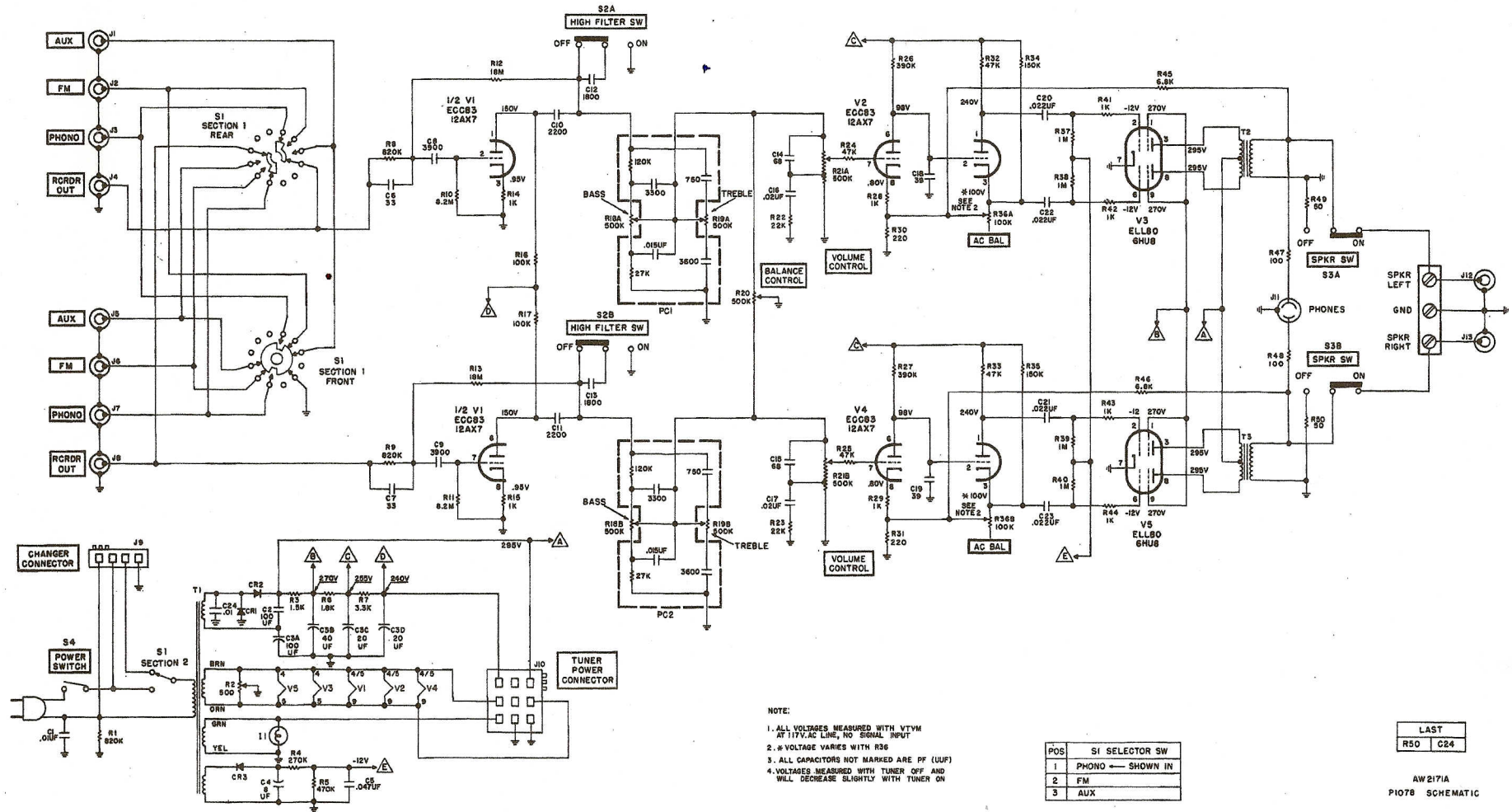

- NOTE:
1. ALL VOLTAGES MEASURED WITH VTVM AT 117V AC LINE, NO SIGNAL INPUT
 2. * VOLTAGE VARIES WITH R36
 3. ALL CAPACITORS NOT MARKED ARE PF (UUF)
 4. VOLTAGES MEASURED WITH TUNER OFF AND WILL DECREASE SLIGHTLY WITH TUNER ON

POS.	S1 SELECTOR SW
1	PHONO — SHOWN IN
2	FM
3	AUX

LAST	
R50	C24

AW2171A
PI078 SCHEMATIC

ALIGNMENT INSTRUCTIONS

Read these instructions very carefully before attempting alignment.

Set the SELECTOR switch to the MONO position.

Set tuning dial to the extreme low-frequency position. Dial pointer should line up with the calibration mark at the low-frequency end of the dial scale. Reset the dial pointer if necessary.)

Warm up the chassis and the test equipment for at least 15 minutes.

Adjust line voltage (power input to chassis) for 117 volts AC 50 to 60 cycles.

(Use only the proper, fully insulated, alignment tools.) Reduce signal generator output during alignment to keep VTVM reading below that specified for step 1.

Repeat steps 4 and 5 to obtain proper dial calibration and maximum sensitivity.

STEP	DIAL	SIGNAL GENERATOR			DC VTVM	ADJUST	INDICATION
		GENERATOR COUPLING	FREQ.	MOD.			
1	Set dial pointer for extreme low-frequency position.	Ungrounded tube shield of V2	10.7 MC	None	Test Point 3*	T1, T2, T3, T4, and T5 top and bottom	Maximum negative voltage (below 20 volts)
2		Ungrounded tube shield of V2	10.7 MC	None	Hot lead of DC VTVM to TEST POINT 4. Ground lead of DC VTVM to junction of two series-connected external resistors (47K 5%), wired between TEST POINT 3 and ground.	T5 top	Zero indication on zero-center dial.
3	90 MC	Two 120-ohm carbon resistors in series with generator leads to the antenna terminals (Figure 1).	90 MC	±22.5 KC deviation at 400 cps.	Through 100K resistor to Test Point 2	L5 and L4	Adjust for maximum negative voltage and check for sinusoidal waveform, with scope, at LEFT or RIGHT output.
4	106 MC		106 MC	±22.5 KC deviation at 400 cps.	Through 100K resistor to Test Point 2	C7 and C6	
5	98 MC		98 MC	±22.5 KC deviation at 400 cps.	Through 100K resistor to Test Point 2	L1	

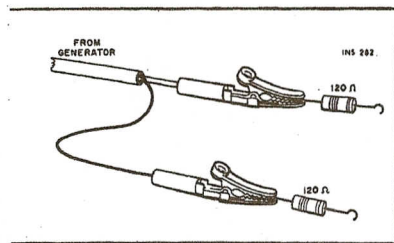

Figure 1. Method of connecting resistors in series with generator leads.

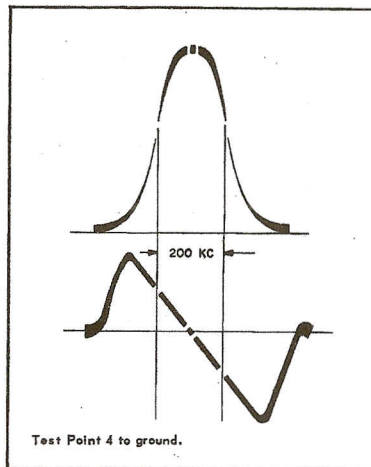
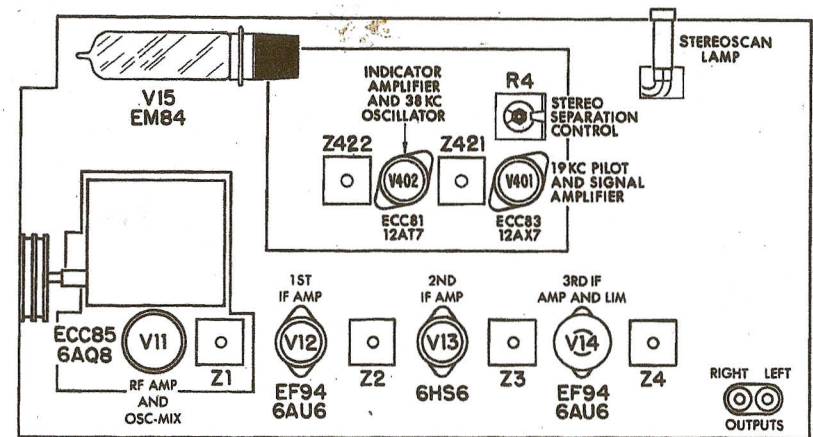

Figure 2. Typical sweep-alignment response curves obtained with properly aligned IF amplifier.

CHASSIS LAYOUT • TUNER



INS189 B

CHASSIS LAYOUT • AMPLIFIER

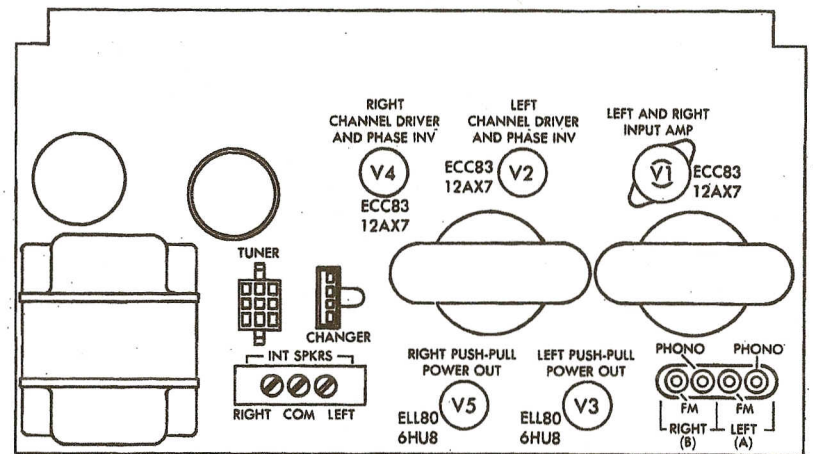

INS190

FISHER RADIO CORPORATION • NEW YORK