

## Resistance Reference Chart

TUBE <sup>S</sup>	SOCKET PINS								
	1	2	3	4	5	6	7	8	9
V1, 6BC8	20K	2M	0	0	.1	19K	2M	0	0
V2, 6CB6	1M	0	0	.1	20K	20K	0	—	—
V3, 6BH6	560K	100	.1	0	20K	20K	0	—	—
V4, 6BH6	.1	100	.1	0	20K	20K	0	—	—
		350*							
V5, 6AM8	220	.1	20K	.1	0	20K	6	16M	0
V6, 6BH6	500K	5K	.1	0	20K	20K	5K	0	0
V7, 6BQ7A	20K	4.7K	0	0	.1	20K	1M	1K	0
V8, 12AX7	220K	500K	2.7K	.1	.1	600K	16M	0	0
V9, 12AU7	70K	1M	2.2K	0	0	20K	200K	630	.1
V10, 6X4	90	—	0	.1	—	90	20K	—	—

**CAUTION:** Be certain to disconnect AC line cord when making these measurements.

**NOTES:** Muting and AFC Control at maximum, counterclockwise. Level Control maximum, clockwise. All resistance in ohms unless otherwise specified.

M equals Megohms

K equals Kilohms

Measurements taken with respect to chassis.

\*Varies with the setting of R-14

## Voltage Reference Chart

TUBE	SOCKET PINS								
	1	2	3	4	5	6	7	8	9
V1, 6BC8	102	— .65	0	0	6.3AC	103	— .7	0	0
V2, 6CB6	— 2.5	0	0	6.3AC	100	100	0	—	—
V3, 6BH6	— .43	.46	6.3AC	0	101	101	0	—	—
V4, 6BH6	0	.58	6.3AC	0	100	100	0	—	—
V5, 6AM8	1.8	0	100	6.3AC	0	100	0	— .8	0
V6, 6BH6	23	24.5	6.3AC	0	100	100	24.5	—	—
V7, 6BQ7A	108	— 3.9	0	0	6.3AC	108	0	3.6	0
V8, 12AX7	65	0	.54	6.3AC	6.3AC	26	— .8	0	0
V9, 12AU7	55	0	2.4	0	0	160	0	5.5	6.3AC
V10, 6X4	196AC	—	0	6.3AC	—	196AC	180	—	—

**NOTES:** Line voltage set at 117 volts, 60 cycles. Voltage readings may vary 10% under normal operating conditions. All voltages read with a vacuum-tube voltmeter under no-signal conditions. Muting Control and AFC Control at maximum, counterclockwise. All voltages read with respect to chassis. Readings are in positive voltages DC unless otherwise specified.

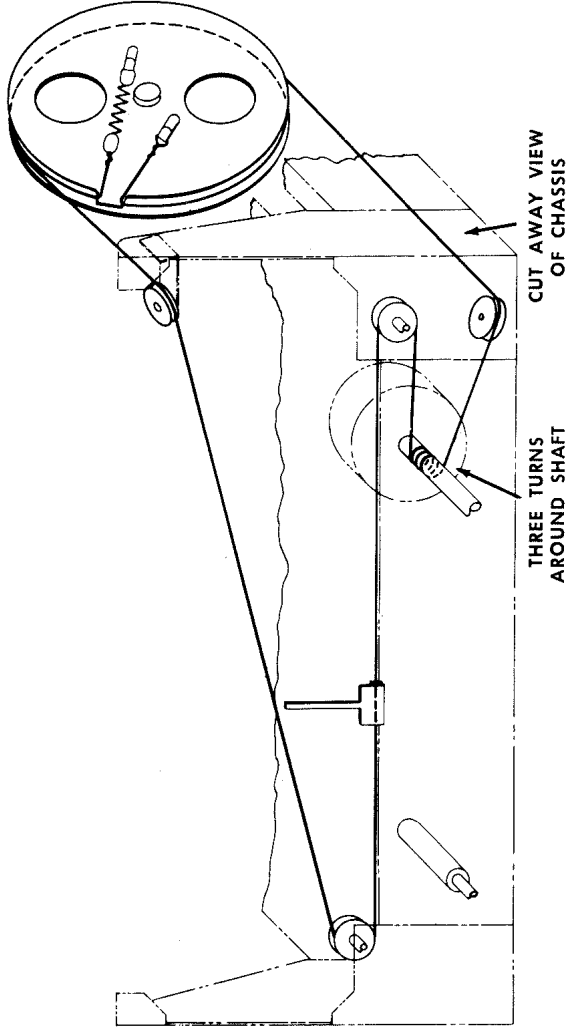

## DIAL CORD REPLACEMENT INSTRUCTIONS

1. Remove defective cord and dial pointer.
2. Restring new cord as shown in illustration.
3. Mount dial pointer, and with variable capacitor fully in counterclockwise position, center pointer over index mark at low-frequency end of dial.
4. Wrap dial string with adhesive type tape where string is inserted under pointer tabs.
5. Secure dial pointer in place by applying household cement.

**FISHER MODEL FM-90**

# Parts Description List

Symbol	Description	Part No.
C-1, C-28	Capacitor, Ceramic: 100 mmfd; 600 V	C-577-121
C-2	Capacitor, Ceramic: 10 mmfd, NPO; 500 V	CC20CH100G5
C-3A-E	Capacitor, Variable	C-551-119
C-3F	Capacitor, Ceramic trimmer: 1-6 mmfd; NPO	C-520-159
C-4, C-5	Capacitor, Ceramic: .005 mfd; 600 V	CK62GP502V6
C-6, C-21	Capacitor, Ceramic: 500 mmfd; 500 V	C-1315
C-7	Capacitor, Ceramic: 33 mmfd; 500 V	CC21GP330M5
C-8	Capacitor, Ceramic: 470 mmfd; Disc	C-520-143
C-9	Capacitor: 2.2 mmfd	C-3039
C-10	Capacitor, Ceramic: .005 mfd; 600 V	CK62GP502V6
C-11	Capacitor, Ceramic: 5 mmfd, NPO; 500 V	CC20CH050F5
C-12, C-13	Capacitor, Ceramic: .005 mfd; 600 V	CK62GP502V6
C-14, C-15	Capacitor, Ceramic: 68 mmfd; disc type	C-551-170
C-16, C-17	Capacitor, Ceramic: 5 mmfd $\pm$ 1 mmfd N1400;	CC20VK050F5
C-18	Capacitor, Ceramic: 500 V	CC20SK050F5
C-19	Capacitor, Ceramic: 5 mmfd $\pm$ 1 mmfd, N330;	CK62GP502V6
C-20	Capacitor, Ceramic: 500 V	C-584-123
C-22, C-24	Capacitor, Ceramic: .005 mfd; 600 V	C-551-146
C-23	Capacitor, Ceramic: .05 mfd	CK62GP502V6
C-25	Capacitor, Electrolytic: 10 mfd; 50 V	C-551-128
C-26, C-27	Capacitor, Ceramic: .005 mfd; 600 V	CC21GP301M5
C-29, C-31, C-36	Capacitor, Ceramic: .02 mfd; 600 V	CC21GP102K5
C-30	Capacitor, Ceramic: 33 mmfd; 500 V	C-556-122
C-32, C-40	Capacitor, Ceramic: .005 mfd; 600 V	CC21GP330M5
C-33, C-34	Capacitor, Ceramic: 68 mmfd, 10%; 500 V	CK62GP502V6
C-35	Capacitor, Electrolytic: 10 mfd; 50 V	CC21GP680K5
C-37	Capacitor, Ceramic: 300 mmfd; 500 V	C-551-128
C-38	Capacitor, Ceramic: 1000 mmfd, 10%; 500 V	CC21GP301M5
C-39	Capacitor, Ceramic: .02 mfd; 600 V	CC21GP102K5
C-41	Capacitor, Molded Tubular: .01 mfd; 600 <sup>W</sup> V	C-556-122
C-42A, B, C, D	Capacitor, Electrolytic: 40 mfd, 250 V, 40 x 40 x 30 mfd; 200 V	C-2747
C-43, C-44, C-45	Capacitor, Ceramic: .005 mfd; 600 V	C-550-130
C-46	Capacitor, Ceramic: .047 mfd; 200 V	CK62GP502V6
C-47	Capacitor, Ceramic: .0047 mfd; 200 V	C68P473M2
C-48	Capacitor, Ceramic: 22 mfd; 200 V	C68P472M2
C-49	Capacitor, Electrolytic: 1 mfd; 250 V	C68P224V2
		C-546-126
I-1, I-2	Lamp, 2 W	I-563-145
J-1, J-6	Jack	J-520-137
J-2, J-3, J-4	Jack, Phono	J-3143
J-5	Socket, Tube Octal	X-1530
L-1, L-2	Coil, Elevator	L-509-139
L-3	Coil, Antenna	L-551-131
L-4	Coil, Neutralization	L-520-178
L-5, L-8, L-9, L-11	Coil, RF choke, 2.2 micro-henry	L-3352
L-6	Coil, RF	L-551-132
L-7	Coil, Oscillator	L-551-133
L-10	Coil, FM Limiter Assembly	L-551-121
L-12, L-13, L-14	Choke Filament	L-520-156
L-15	Coil, Bifilar	L-509-140
L-16	Dipole, Assembly	AS-520-163
M-1	Meter, Signal	M-551-134
M-2	Meter, Tuning	M-551-169
P-1	Plug, 4 male contacts	P-520-138
R-1	Resistor, Composition: 470,000 ohms, 10%; $\frac{1}{2}$ W	RC20BF474K
R-2, R-20	Resistor, Composition: 1 megohm, 10%; $\frac{1}{2}$ W	RC20BF105K
R-3	Resistor, Composition: 470 ohms, 10%; $\frac{1}{2}$ W	RC20BF471K
R-4, R-5	Resistor, Composition: 1 megohm, 10%; $\frac{1}{2}$ W	RC20BF105K
R-6	Resistor, Composition: 33,000 ohms, 10%; $\frac{1}{2}$ W	RC20BF333K
R-7	Resistor, Composition: 1000 ohms, 10%; $\frac{1}{2}$ W	RC20BF102K
R-8, R-25	Resistor, Composition: 470,000 ohms, 10%; $\frac{1}{2}$ W	RC20BF474K
R-9	Resistor, Composition: 100 ohms, 10%; $\frac{1}{2}$ W	RC20BF101K
R-10	Resistor, Composition: 330,000 ohms, 10%; $\frac{1}{2}$ W	RC20BF334K
R-11	Resistor, Composition: 1500 ohms, 10%; $\frac{1}{2}$ W	RC20BF132K
R-12, R-16	Resistor, Composition: 1000 ohms, 10%; $\frac{1}{2}$ W	RC20BF102K
R-13, R-19	Resistor, Composition: 100 ohms, 10%; $\frac{1}{2}$ W	RC20BF101K
R-14	Potentiometer, 250 ohms; wirewound	R-550-135-2
R-15	Resistor, Composition: 330,000 ohms, 10%; $\frac{1}{2}$ W	RC20BF334K
R-17	Resistor, Composition: 4700 ohms, 10%; $\frac{1}{2}$ W	RC20BF472K
R-18, R-22	Resistor, Composition: 1000 ohms, 10%; $\frac{1}{2}$ W	RC20BF102K
R-21	Potentiometer, 1500 ohms; wirewound	R-520-149
R-23	Resistor, Composition: 33,000 ohms, 10%; 1 W	RC30BF333K
R-24 A & B	Potentiometer, Dual with switch	R-551-136
R-26	Resistor, Composition: 220 ohms, 10%; $\frac{1}{2}$ W	RC20BF221K
R-27, R-28	Resistor, Composition: 220,000 ohms, 10%; $\frac{1}{2}$ W	RC20BF224K
R-29	Resistor, Composition: 22,000 ohms, 10%; $\frac{1}{2}$ W	RC20BF223K
R-30	Resistor, Composition: 15 megohms, 10%; $\frac{1}{2}$ W	RC20BF156K
R-31, R-33	Resistor, Composition: 220,000 ohms, 10%; $\frac{1}{2}$ W	RC20BF224K
R-32	Resistor, Composition: 1000 ohms, 10%; $\frac{1}{2}$ W	RC20BF102K
R-34	Resistor, Composition: 100,000 ohms, 10%; $\frac{1}{2}$ W	RC20BF104K
R-35	Resistor, Composition: 470,000 ohms, 10%; $\frac{1}{2}$ W	RC20BF474K
R-36	Resistor, Composition: 4700 ohms, 10%; $\frac{1}{2}$ W	RC20BF472K
R-37, R-50	Resistor, Composition: 47,000 ohms, 10%; $\frac{1}{2}$ W	RC20BF473K
R-38, R-44	Resistor, Composition: 2200 ohms, 10%; $\frac{1}{2}$ W	RC20BF222K
R-39	Resistor, Composition: 68,000 ohms, 10%; $\frac{1}{2}$ W	RC20BF683K
R-40, R-41	Resistor, Composition: 10,000 ohms, 10%; $\frac{1}{2}$ W	RC20BF103K
R-42	Resistor, 220 ohms, 10% 5 W	R-551-137
R-43A, B	Resistor, Wirewound: 910 ohms, tapped at 330 ohms	R-551-138
R-45	Potentiometer, Composition: 500,000 ohms	R-520-139
R-46	Resistor, Composition: 220,000 ohms, 10%; $\frac{1}{2}$ W	RC20BF224K
R-47	Resistor, Composition: 2700 ohms, 10%; $\frac{1}{2}$ W	RC20BF272K
R-48	Resistor, Composition: 33,000 ohms, 10%; $\frac{1}{2}$ W	RC20BF333K
R-49, R-52	Resistor, Composition: 1 megohm, 10%; $\frac{1}{2}$ W	RC20BF105K
R-51	Resistor, Composition: 2200 ohms, 10%; $\frac{1}{2}$ W	RC20BF222K

## MISCELLANEOUS PARTS

Dress Panel  
 Dress Panel Escutcheon  
 Knob, Tuning  
 Knob, AFC  
 Knob, Muting  
 Dial Glass

AS-551-168  
 AS-551-172  
 E-50049-5  
 E-50049-2  
 E-50049-4  
 N-551-117

# FISHER MODEL FM-90

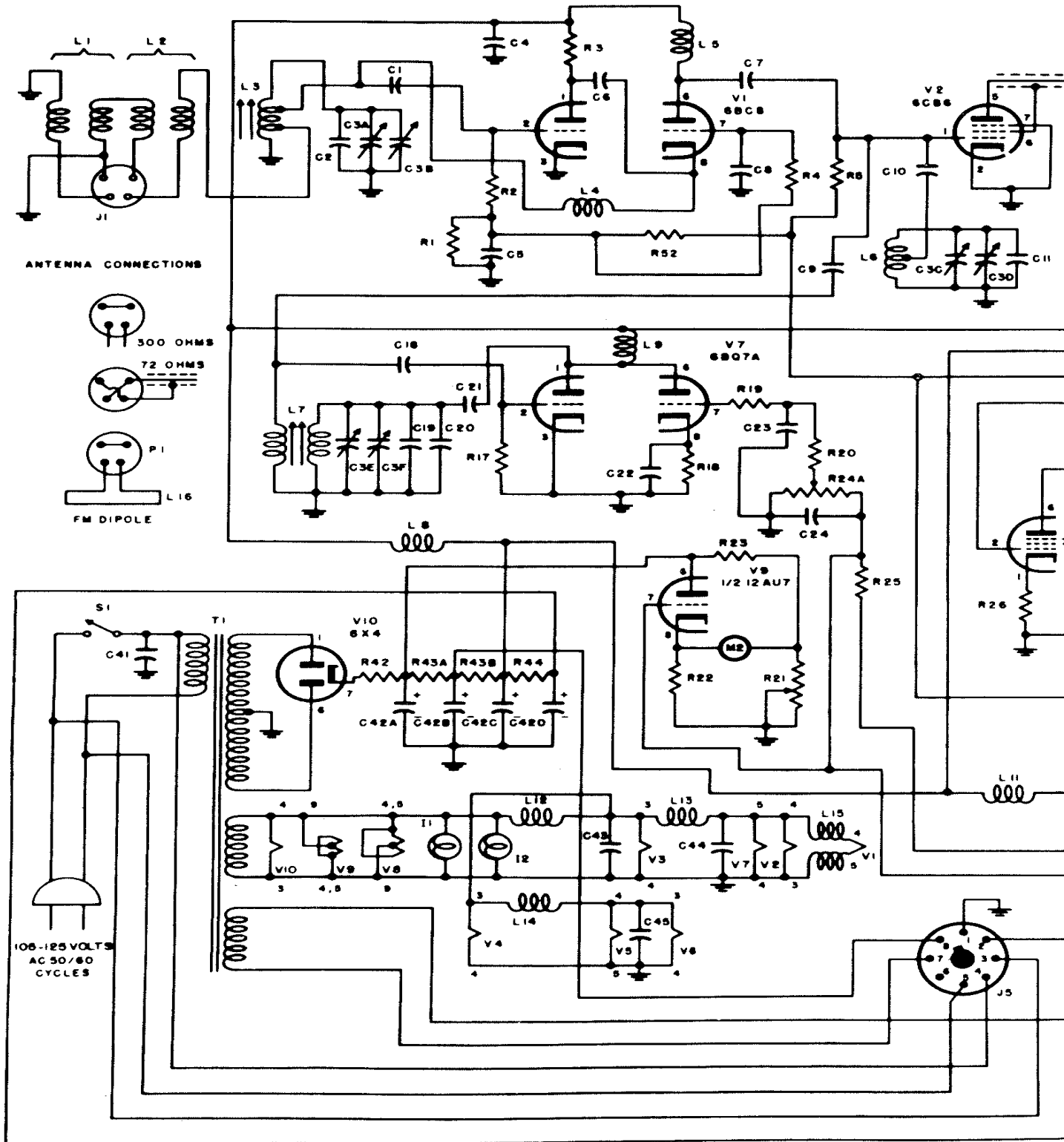

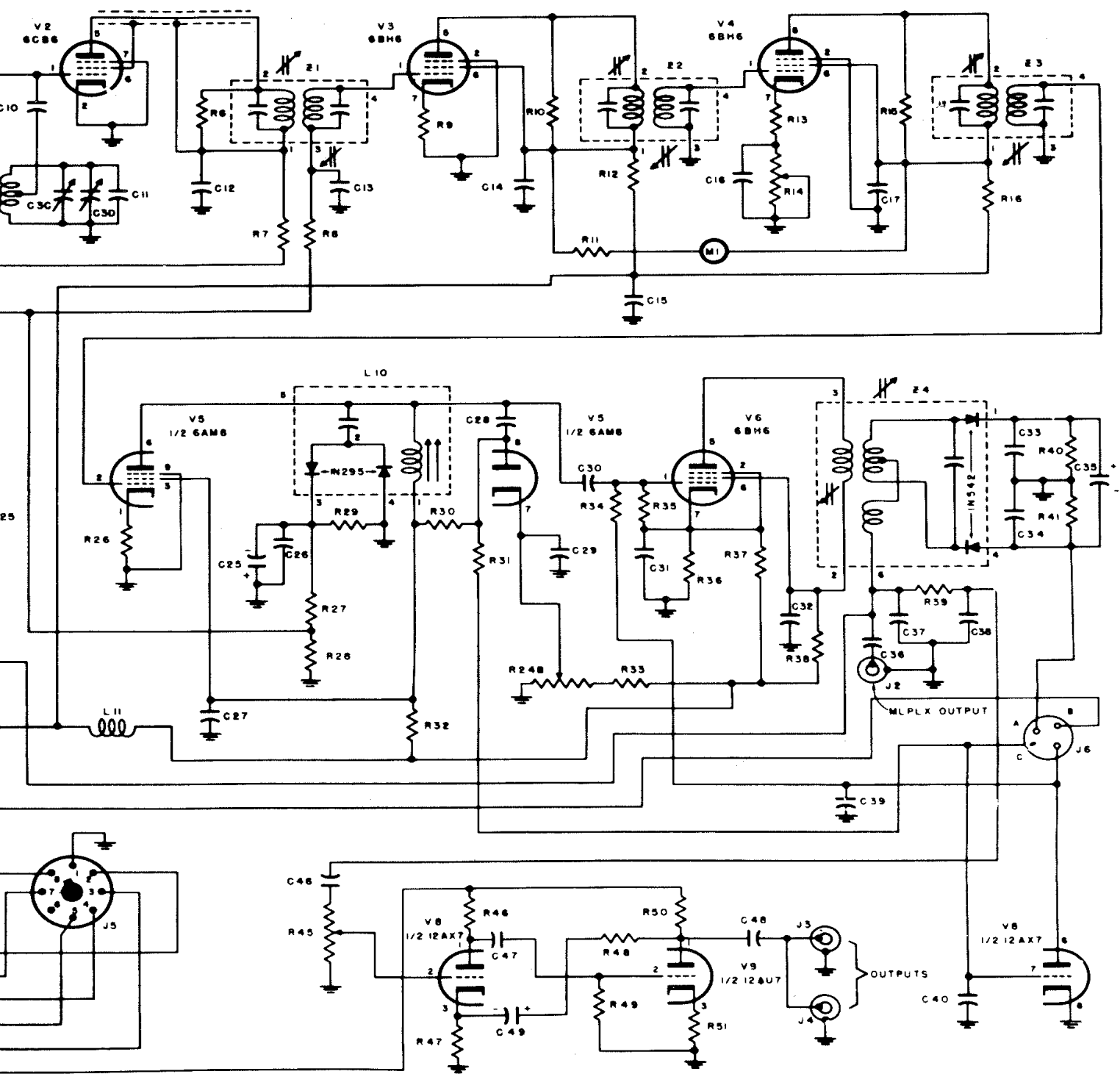

SCHEMATIC DIAGRAM COURTESY FISHER RADIO CORP