

Service Manual

DVD Home Theater System

FILE NO.

DWM-1000 (US)

HTD-5201 (XE)

(UK)

(SS)

(KR)

(US)

(CA)

(AU)

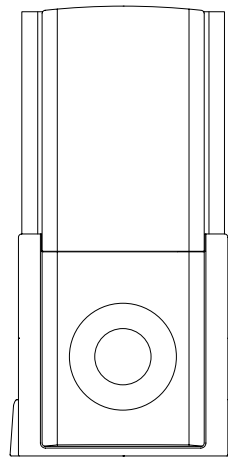
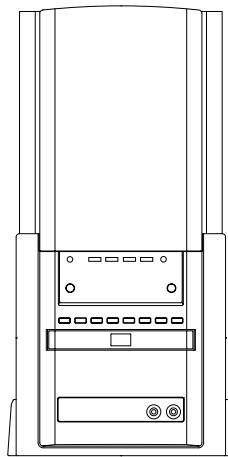

PRODUCT CODE No.

129 590 00 (1000)

129 590 01 (XE)

129 590 02 (UK)

129 590 03 (SS)

129 590 04 (KR)

129 590 05 (US)

129 590 06 (CA)

129 590 07 (AU)

CONTENTS

Specifications	1	Wiring Diagram (MPEG A SIDE)	76
Laser beam safety precaution	2	Wiring Diagram (MPEG B SIDE)	78
DVD mechanism replacement	2	Schematic Diagram (AMP for 1000,US,CA)	80
Removal & Installation	3	Wiring Diagram (Pre AMP,Power AMP,Video AMP, Socket-A for 1000,US,CA)	82
Mechanism replacement	4	Schematic Diagram (AMP for XE,UK)	86
Mechanism operation	5	Wiring Diagram (Pre AMP,Power AMP,Video AMP, Socket-A for XE,UK)	88
DVD P.W.Board operation	6	Schematic Diagram (AMP for SS)	92
DVD P.W.Board operation (Schematic diagram for signal check)	8	Wiring Diagram (Pre AMP,Power AMP,Video AMP, Socket-A for SS)	94
DVD P.W.Board operation (Wiring diagram for signal check)	18	Schematic Diagram (AMP for KR)	98
DVD P.W.Board operation(Signal)	20	Wiring Diagram (Socket-A for KR)	100
DVD start-up program flow chart	28	Wiring Diagram (Regulator & Digital Out)	101
How to load software for MPEG P.W.Board	30	Schematic Diagram (AMP for AU)	102
MPEG and FRONT END		Wiring Diagram (Pre AMP,Power AMP,Video AMP, Socket-A for AU)	104
P.W.Board operation (Block diagram)	30	Wiring Diagram (Front for 1000,US,CA)	108
MPEG P.W.Board operation (schematic diagram for waveform check)	32	Wiring Diagram (Front for XE,UK)	109
MPEG and FRONT END		Schematic Diagram (Front for 1000,XE,UK,US,CA)	110
P.W.Board check waveform	34	Schematic Diagram (Front for SS,KR)	112
Trouble shooting	41	Wiring Diagram (Front for SS,KR)	114
Voltage of IC & Transistor	44	Wiring Diagram (Front for AU)	115
Exploded view (Cabinet & Chassis)	47	Schematic Diagram (Front for AU)	116
Parts list	48	Schematic Diagram (DVD)	118
Parts list & Exploded view (SP box)	57	Wiring Diagram (DVD A side)	128
Exploded view (DVD mechanism)	58	Wiring Diagram (DVD B side)	129
IC Block diagram & description	59	Wiring Connection (1000,US,CA,AU)	130
Memo	73	Wiring Connection (XE,UK,SS,KR)	Rear
Schematic Diagram (MPEG)	74		

This service manual consists of "DWM-1000M"[US](Main unit: 129 591 00), "DWM-1000SP"[US](Speaker system: 165 029 00), "HTD-5201M"[XE](Main unit: 129 591 01), [UK](Main unit: 129 591 02), [SS](Main unit: 129 591 03), [KR](Main unit: 129 591 04), [US](Main unit: 129 591 05), [CA](Main unit : 129 591 06), [AU](Main unit: 129 591 07), "SX-5201/XE" [XE](Speaker system: 165 029 01), "SX-5201/SS" [UK,SS,KR,AU](Speaker system: 165 029 02), "STM-5201/US" [US](Speaker system: 165 029 04) and SX-5201/CA[CA](Main unit: 165 029 05).

SPECIFICATIONS

Main unit with Main Speaker Amplifier Section

<US>
Main Amplifier
Continuous minimum sine wave RMS power output per channel at 1kHz into 6 ohms with no more than 10 % total harmonic distortion 30 Watts

Subwoofer Amplifier
Continuous minimum sine wave RMS power output at 100Hz into 6 ohms with no more than 10 % total harmonic distortion 30 Watts

General

Output power

Total power : 90W
Main Amplifier : 30 x 2 (at 6 ohms, 10% distortion)
Subwoofer Amplifier : 30W (st 6 ohms, 10% distortion)

Input level and impedance:

VIDEO: VIDEO IN : 1.0 Vp-p (75 ohms)
AUDIO IN (L/R): 600 mV/50k ohms
AUX/TV (L/R): 600 mV/50k ohms

Outputs:

MAIN SPEAKER (L/R): 6 ohms
SUBWOOFER: 6 ohms
PHONES: 8-32 ohms (XE, UK, SS, KR, AU)
DIGITAL OUT: Optical
AV EURO CONNECTOR : For Euro-AV cable (XE, UK)
COMPONENT VIDEO OUT: C_B/C_R: 0.7 Vp-p (75)
Y: 1.0 Vp-p (75)
MONITOR VIDEO OUT: 1.0 Vp-p (75 ohms)
AUDIO OUT (L/R): 600 mV (1 kohms)
S-VIDEO OUT: Y: 1.0 Vp-p (75 ohms)NTSC
Y: 1.0 Vp-p (75 ohms)PAL
C: 0.286 Vp-p (75 ohms)NTSC
C: 0.3Vp-p (75 ohms)PAL

DVD Video Player Section

Type: DVD/CD player
Playback standard : PAL or NTSC
Laser: Semiconductor laser, wavelength 650 nm
Laser output (Continuous wave max.)
1mW (DVD)
0.5mW (CD)
Frequency range (digital audio):
4 Hz to 44 kHz (DVD fs: 96 kHz)
Signal to noise ratio: More than 105 dB
Harmonic distortion (digital audio): 0.003 %
Wow and flutter: Below measurable level

Main Speaker (magnetic shield)

Unit used: 10cm (4" diameter), Cone type
Maximum music power handling capacity: 60 Watts
Nominal impedance: 6 ohms

General

Power requirements: AC 120V, 60Hz (1000,US,CA)
AC 230V, 50Hz (XE,UK)
AC 230-240V,50Hz (AU)
AC 220V, 60Hz (KR)

Power consumption: 100 Watts

1.4W (standby mode)

Dimensions (W x H x D): Approx. 200(W) x 400(H) x 320(D) mm
Approx. 7.9" x 15.9" x 12.6"

Weight : Approx. 8.7 kg (19.4 lbs)

Main Speaker with Subwoofer (magnetic shield)

Main Speaker

Unit used: 10cm (4" diameter), Cone type
Maximum music power handling capacity: 60 Watts(peak)
Nominal impedance: 6 ohms

Subwoofer

Unit used: 13cm (5.1" diameter), Cone type
Maximum music power handling capacity: 60 Watts (peak)
Nominal impedance: 6 ohms

General

Dimensions (W x H x D): Approx 200(W) x 400(H) x 320(D) mm
Approx. 7.9" x 15.9" x 12.6"

Weight: Approx. 5.8 kg (13.2 lbs)

IMPORTANT INFORMATION

Because its products are subject to continuous improvement, SANYO reserves the right to modify product designs and specifications without notice and without incurring any obligation.

Specifications subject to change without notice.

LASER BEAM SAFETY PRECAUTION

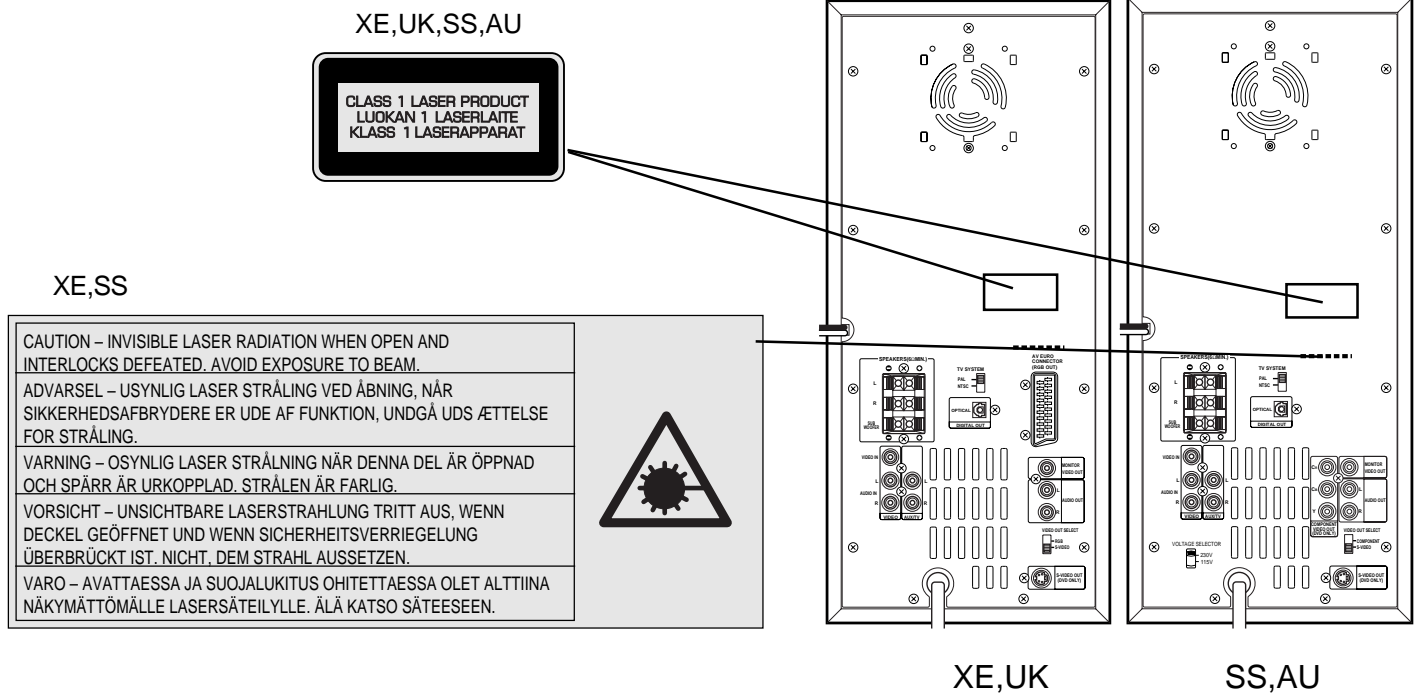

DVD MECHANISM REPLACEMENT

1. Cautionary instructions in handling the assy
(Safety instructions)

Optical pickup

The laser beam used in the pickup is classified as "class 2". Exposing your eyes or skin to the beam is harmful. Take care not to do so.

(Caution against static electricity and leakage voltage)

Ground securely the work tables, tools, fixtures, soldering irons (including those made of ceramic) and measuring instruments used in the production lines and inspection departments that handle loaders. The workers shall also be grounded.

(Cautionary instructions in handling)

Do not touch the object lens when handling a loader, or the lens will be stained, resulting in inadequate playability.

There is no power supply protection circuit provided for this product or adjustment/inspection device. Short-circuiting may lead to fire or damage.

Take care so as to protect from exposure to water, the entry of metallic pieces or dew condensation.

In particular, a strong magnet adjacent to the pickup will not only get inoperative but can damage the pickup if a small metallic piece, such as a screw or swarf, enters.

The loader edge can cause injury if inadvertently handled.

Do not touch a rotating disk, or injury may result.

This product is a precision device. Handle carefully.

A shock or dropping will cause misalignment or destruction. If it should occur, refer to clause 2.

This product is so designed as to endure an initial shock equivalent to a drop from a height of approx. 90 cm under the packed condition. After the initial shock, the resistivity will still remain at a level of 50 to 60 G, but the mechanical robustness

The entry and deposition of dirt into or on the pickup lens or moving section will cause malfunction or degradation.

(Connectors)

Do not connect or disconnect while power is on.

Connecting or disconnecting signal wires or the main power cord when the power is on may destruct the unit or fixture.

When connecting, push all the way in securely.

An insufficient insertion may cause a bad contact, leading to an erroneous operation.

Do not connect or disconnect roughly by an excessively strong force, or a broken wire or bad contact may result.

Semiconductors are connected. Do not touch connector terminals directly.

If the worker is grounded, there is nothing to worry about static electricity, but the rust on the connector terminal surface caused by the touch may result in bad contact.

(Power source)

The power source need be good in quality (free from instantaneous interruptions or noises).

A low quality power source may well cause malfunction.

(Storage)

Do not place or store in a dusty place or a place where dew condensation is possible.

The entry and deposition of dirt or dust into or on the pickup lens or moving section will cause malfunction or degradation.

Also, dew condensation causes rust ; the rust penetrate into the precision part of a pickup, causing malfunction, or degrading the optical quality of the internal lens and reflector, which also leads to malfunction.

REMOVAL & INSTALLATION

Remove the power supply cord from AC outlet.

All wiring should be returned to the original position after work is completed.

Check and maintenance can do, if operate the following order.

1. Removal Rear Panel

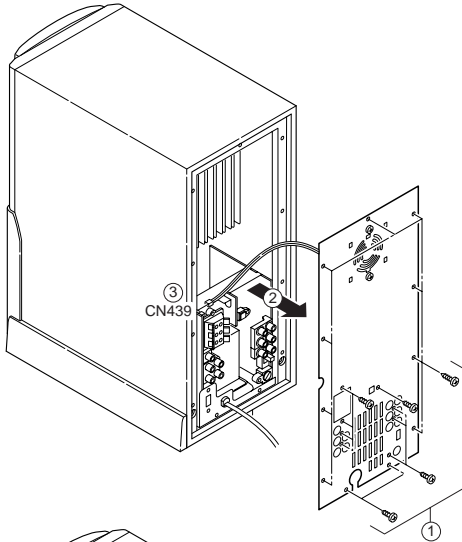

2. Removal Power supply P.W.B.

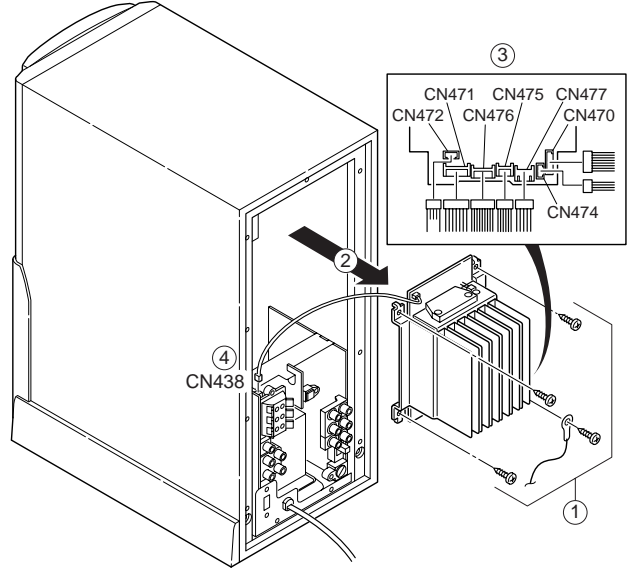

UK,XE only

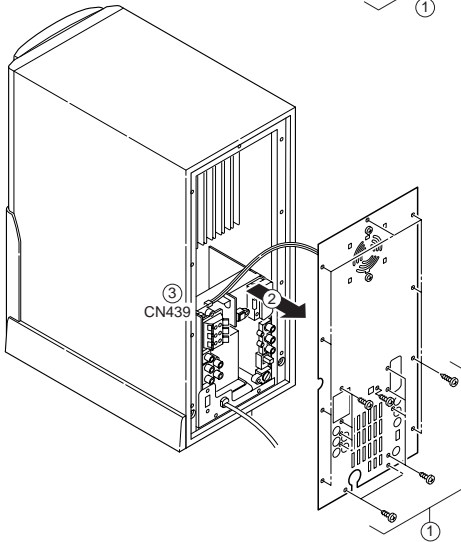

3. Removal Front grill Block

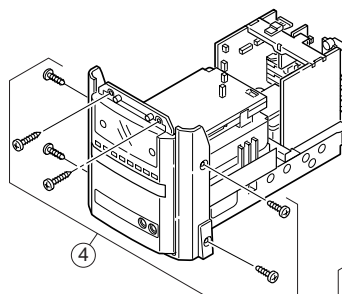

1000,XE,UK,US,CA,AU

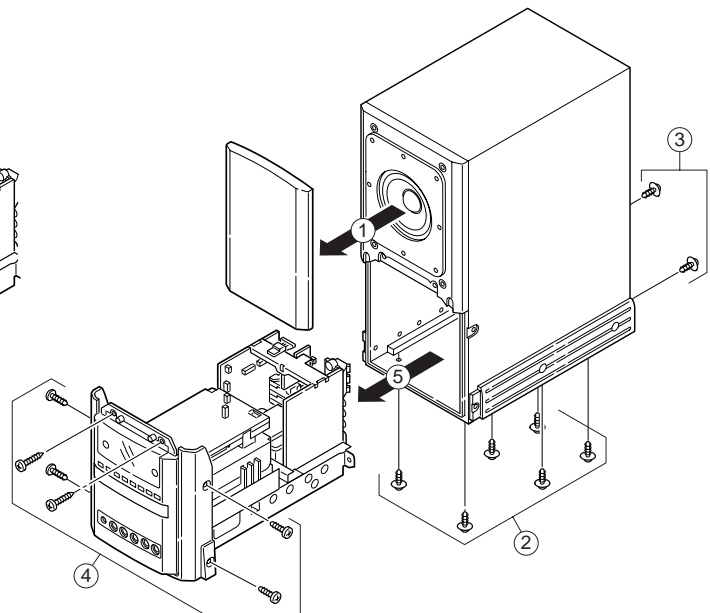

SS,KR

MECHANISM REPLACEMENT

1. TRAY and BASE Mechanism Part

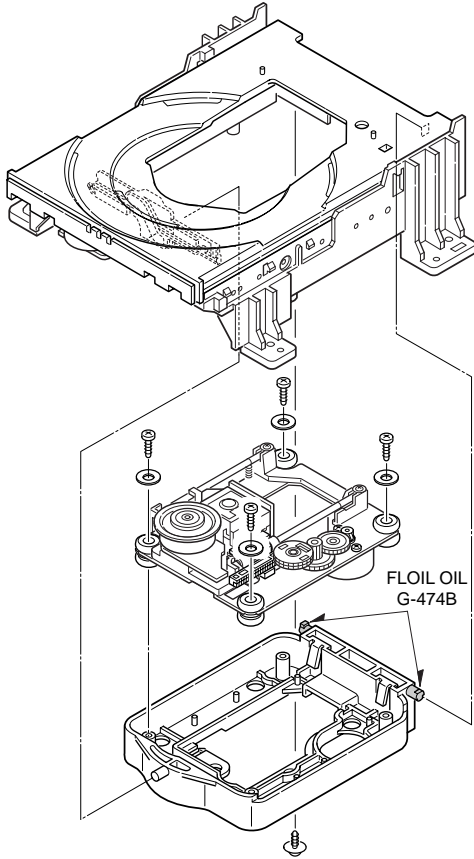

3. TRAY Part

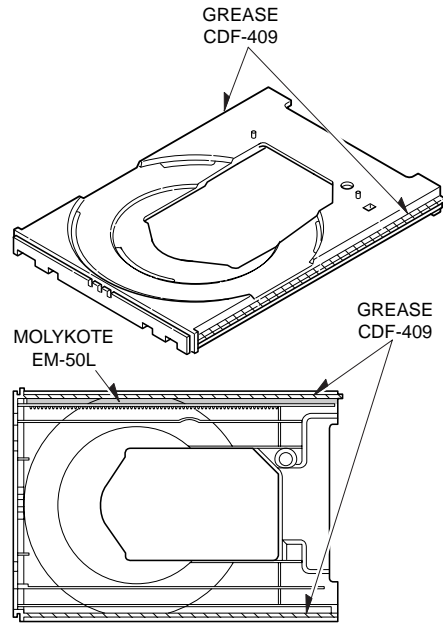

2. BASE Mechanism Mounting Part

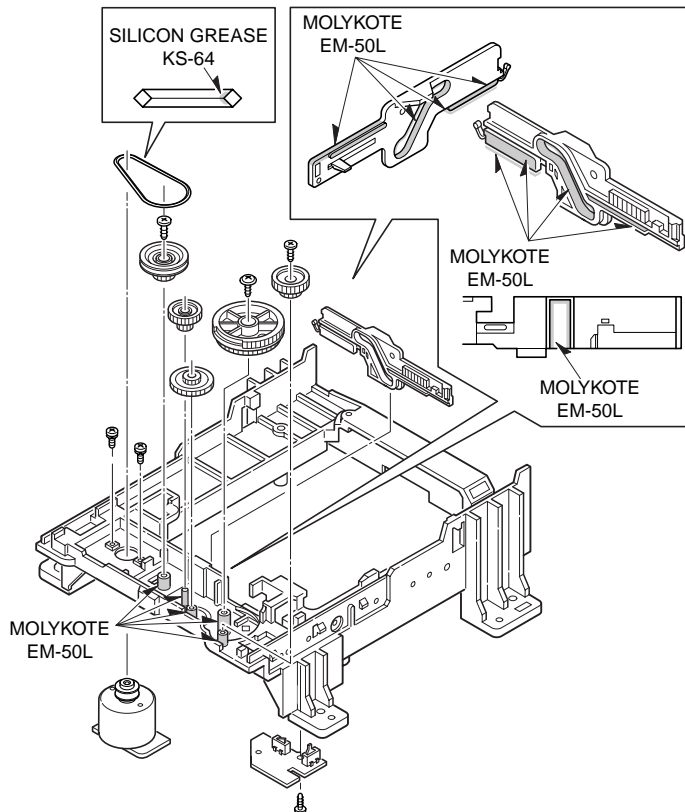

4. BASE Mechanism Part

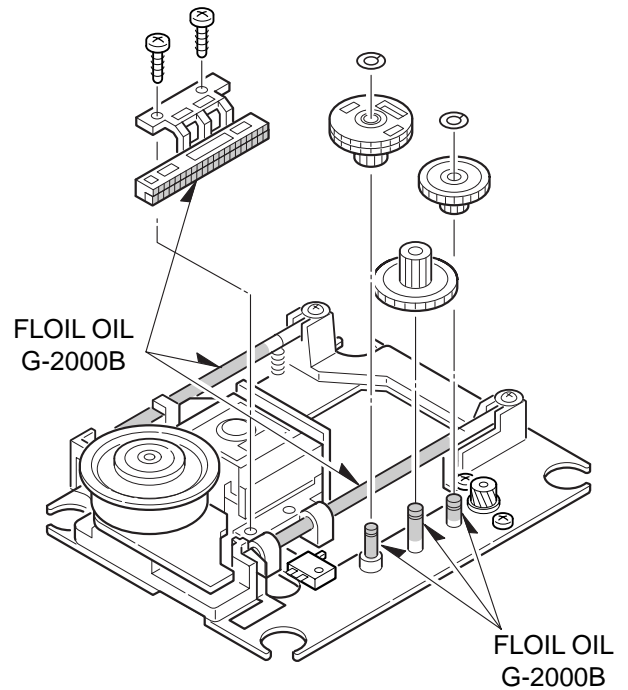

Do not remove the pick-up from base mechanism because of adjustment difficulty.

MECHANISM OPERATION

1. How to setting the TRAY

1. Move the SLIDE left side.
2. Match the Hole of GEAR ⑤ and Hole of CHASSIS ④.

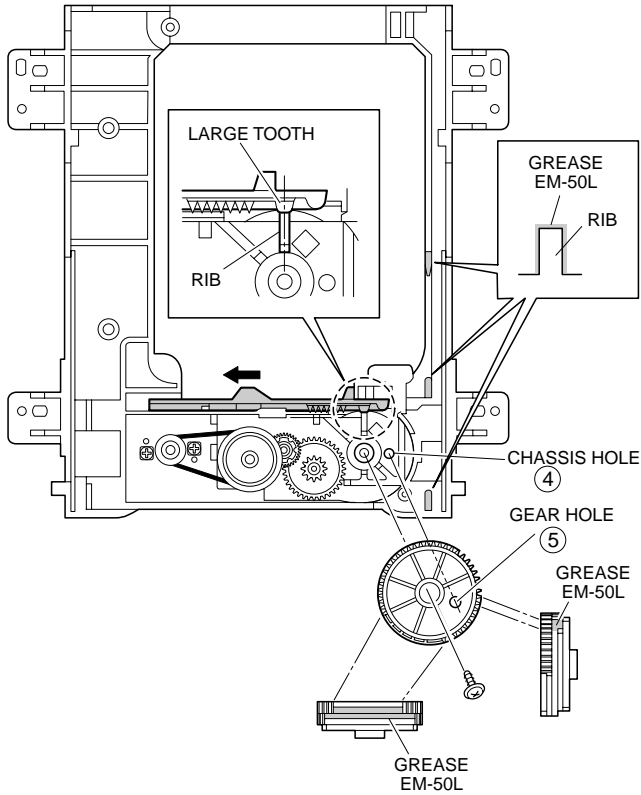

3. Match the mark of GEAR ② and mark of GEAR ③, and then install the BOSS.
4. Turn the GEAR ① counterclockwise, and then SLIDE move right side.
5. The GEAR ① move from side to side.

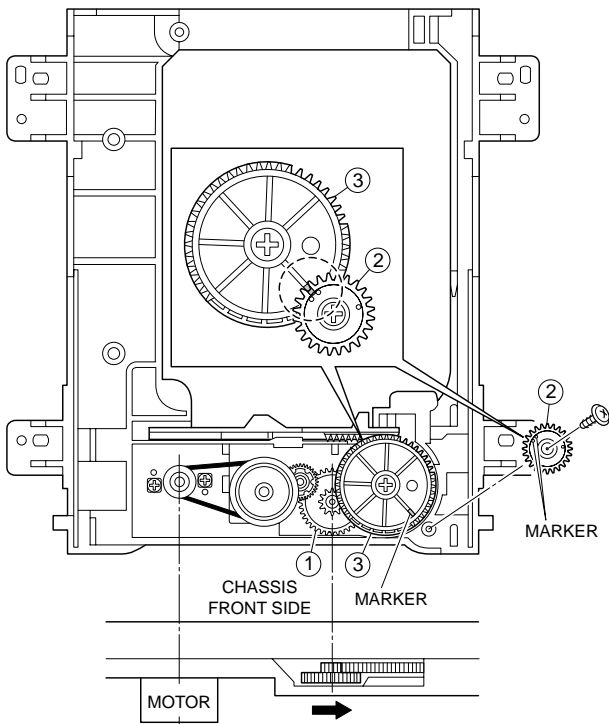

6. Match the hole of GEAR ⑦ and hole of chassis while turning GEAR ⑥.
7. Match the mark of LOADING GEAR ⑧ and gear of TRAY where see horn hole ⑨ of tray.
8. Push a TRAY with the state that turned the entire surface of a TRAY into approximately 5 degrees the lower part slowly.

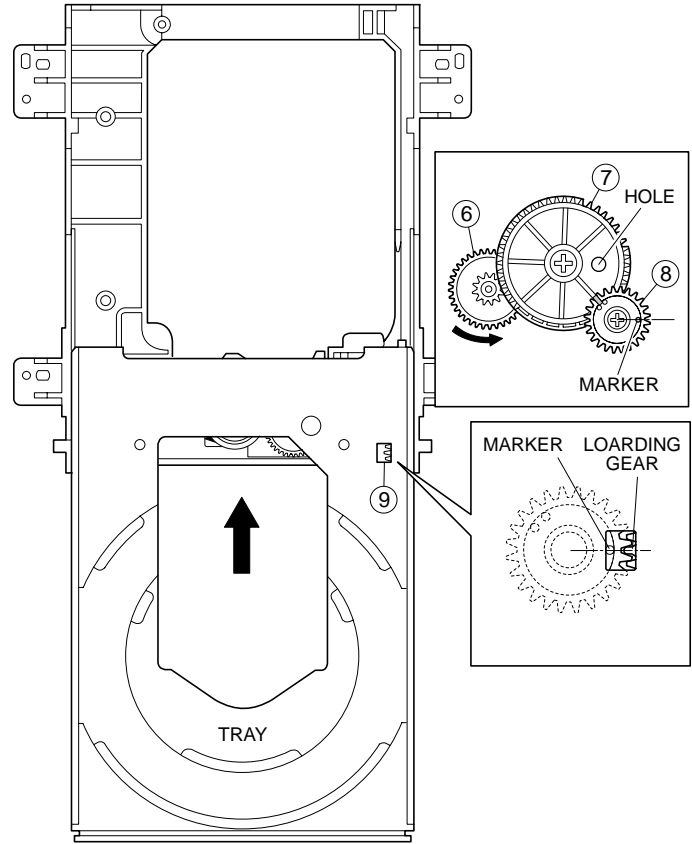

DVD P.W.BOARD OPERATION

1. General operation diagram (This is a basic general operation diagram)

The circuit mounted on the Loader part (Frontend Board) is configured as shown, which is divided into following blocks according to main IC's.

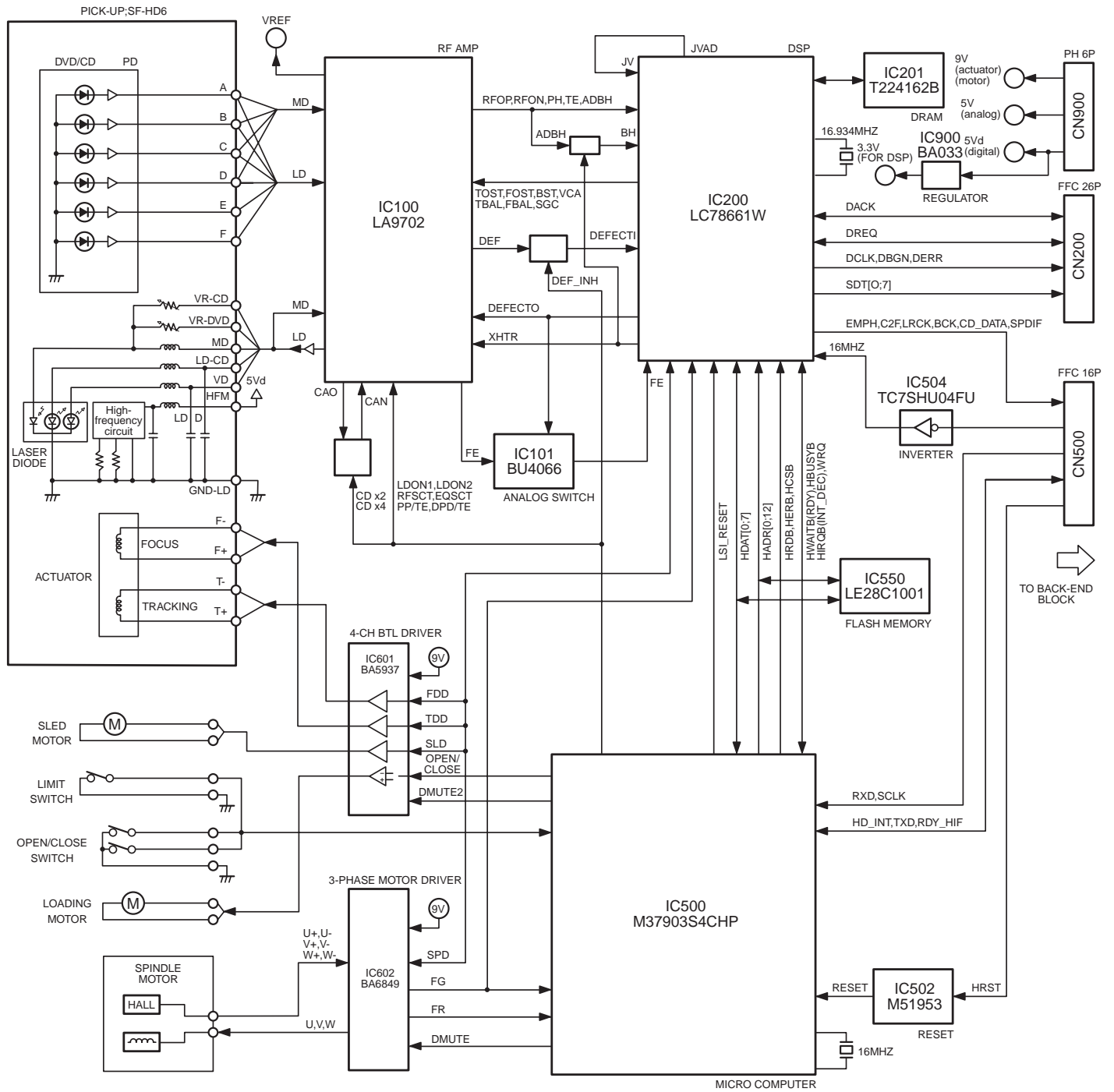

DVD P.W.BOARD OPERATION

2. Circuit configuration inside IC100 (LA9702W) and IC200 (LC78661W). (This is a basic circuit configuration diagram)

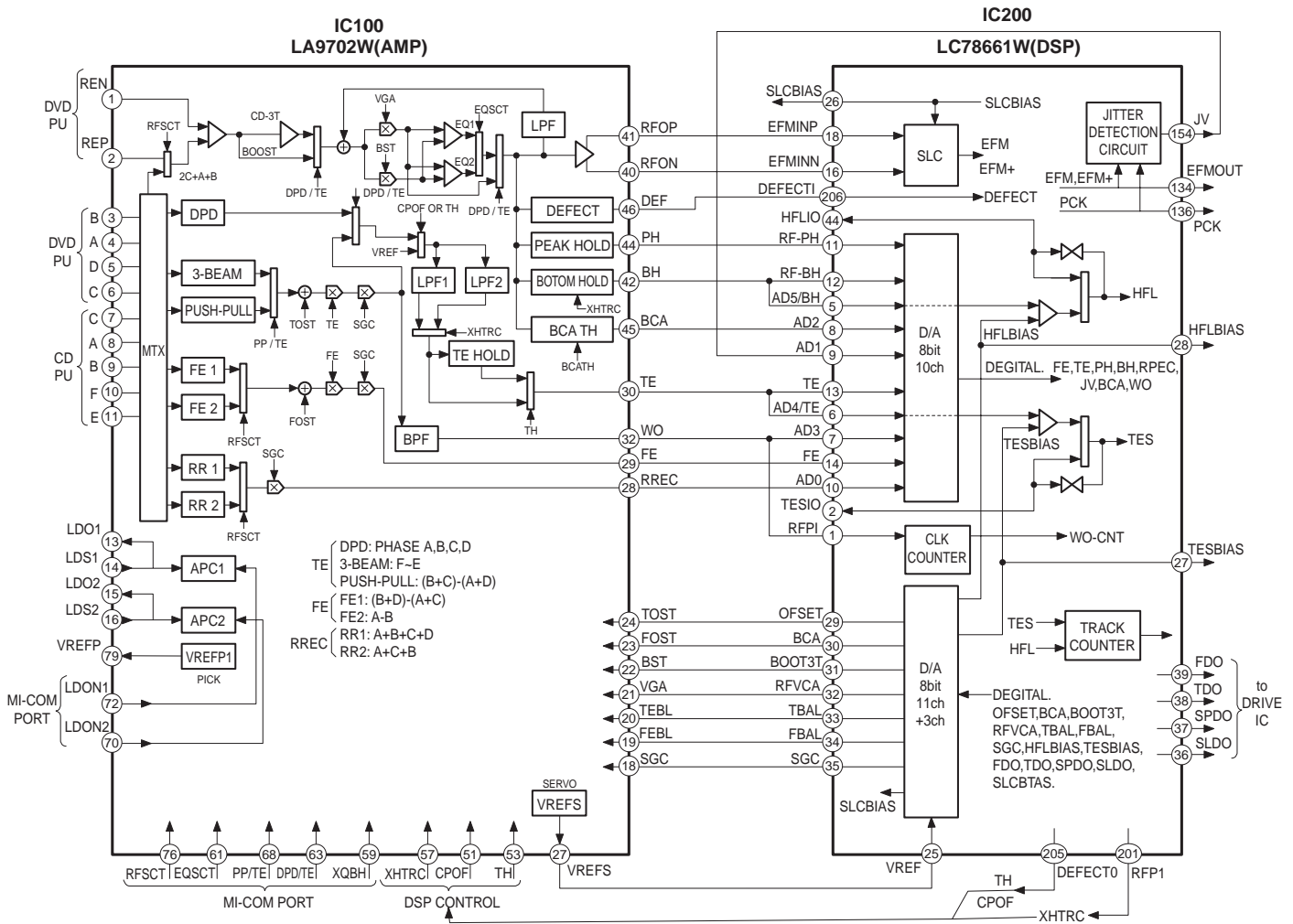

Name	TP label	IC, CN Location	Pin no.	Description	Name	TP label	IC, CN Location	Pin no.	Description
FE	TP101	IC100	25	Focus Error Signal(Analog)	TD	TP601	IC200	38	Tracking Driver out(analog)
TE	TP102	IC100	30	Tracking Error Signal(Analog)	FD	TP602	IC200	39	Focus Driver out(analog)
RFN	TP104	IC100	40	RF Signal(Analog)	SPD-FG	TP604	IC602	24	Spindle FG signal
RFP	TP105	IC100	41	RF Signal(Analog)	W	TP621	-----	-----	Spindle Coil Voltage
BH	TP106	IC100	42	Bottom Hold Signal(Analog)	V	TP620	-----	-----	
PH	TP107	IC100	44	Peak Hold Signal(Analog)	U	TP611	-----	-----	
DEF	TP230	IC100	46	High : When passing defection	H+	TP619	-----	-----	
LD1	TP122	Q1004	E	DVD Laser Power Supply(Analog)	U+	TP618	-----	-----	Spindle Hall Voltage
LD2	TP124	Q1005	E	CD Laser Power Supply(analog)	U-	TP617	-----	-----	
TESIO	TP201	IC200	2	TES(Track crossing signal)	V+	TP616	-----	-----	
HFLBIAS	TP204	IC200	28	MIRROR Slice Bias(Analog)	V-	TP615	-----	-----	
HFLIO	TP206	IC200	44	MIRROR signal	W+	TP614	-----	-----	Sled Driver out(analog)
FSEQ	TP211	IC200	84	High : Sync synchronised LO : Async	W-	TP613	-----	-----	
EFMOUT	TP226	IC200	134	RF Digitized signal	H-	TP612	-----	-----	
DEFECT0	TP229	IC200	201	High : When passing defection	SLD	TP607	IC200	36	
TOST	TP246	IC200	29	Tracking Offset Control(analog)	SPD	TP608	IC200	37	Spindle Driver out(analog)
FOST	TP247	IC200	30	Focus Offset Control(analog)	OPEN	-----	IC601	16	TRAY control signal
BOOST3T	TP248	IC200	31	RF EQ Control(analog)	CLOSE	-----	IC601	15	TRAY control signal
RFVCA	TP249	IC200	32	RF Voltage Control(analog)	OPEN-SW	TP627	CN600	5	TRAY Limit SW
TBAL	TP250	IC200	33	Tracking Balance Control(analog)	CLOSE-SW	TP626	CN600	3	TRAY Limit SW
FBAL	TP251	IC200	34	Focus Balance Control(analog)	HRST	TP700	CN500	2	RESET from Backend
SGC	TP252	IC200	35	Signal Gain Control(analog)	RESET	-----	IC502	6	RESET to Micom
HFBUSYB	TP254	IC200	50	Function Busy Low during jump, adjustment so on.	VREF	-----	IC100	27, 79	Reference Voltage(2.5V)
JVAO	TP257	IC200	154	Jitters value(analog)					

TROUBLE SHOOTING

(This is a basic trouble shooting.)

General flow

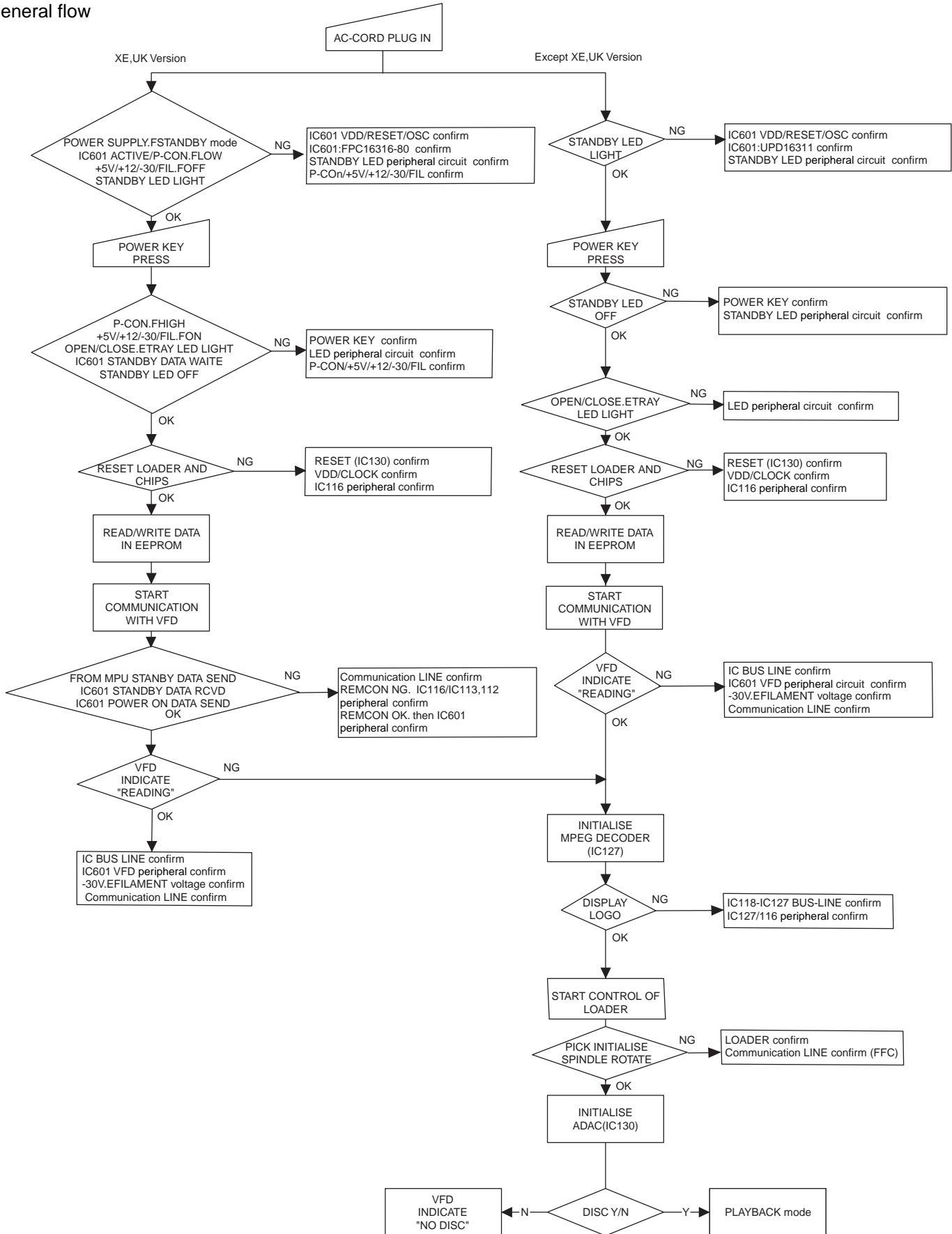

TROUBLE SHOOTING

(This is a basic trouble shooting.)

AUDIO PART

1. When time display OK and sound NG or When S/PDIF OK and analogue NG.

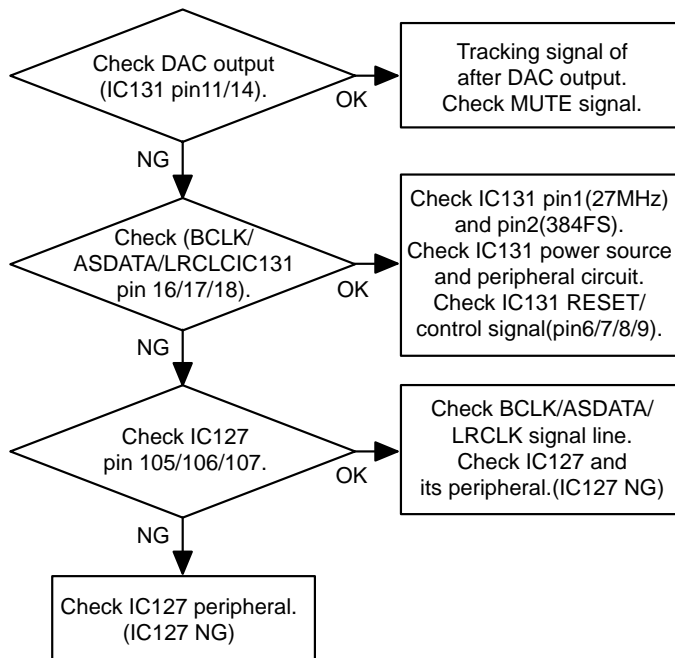

2. When time display NG and sound NG.

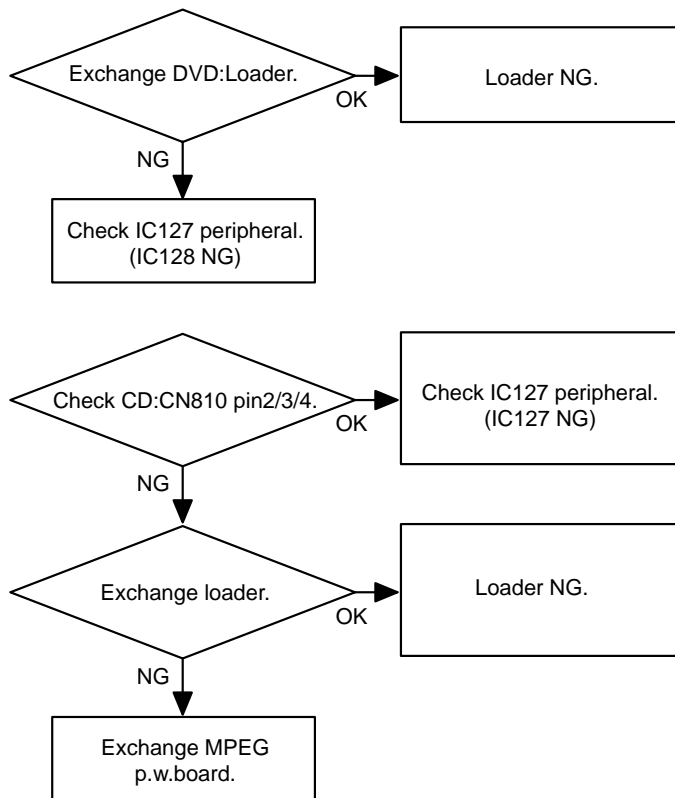

3. When S/PDIF NG and analogue OK.

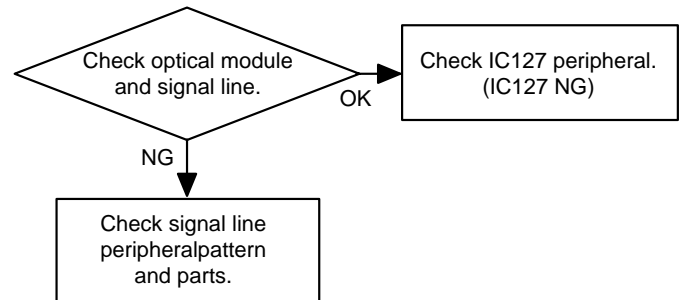

4. When S/PDIF NG and analogue NG.

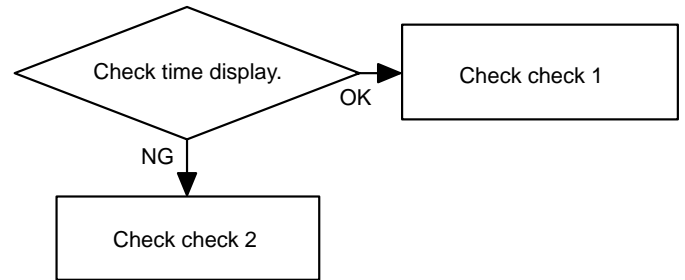

5. When pop noise (when usual operate.)

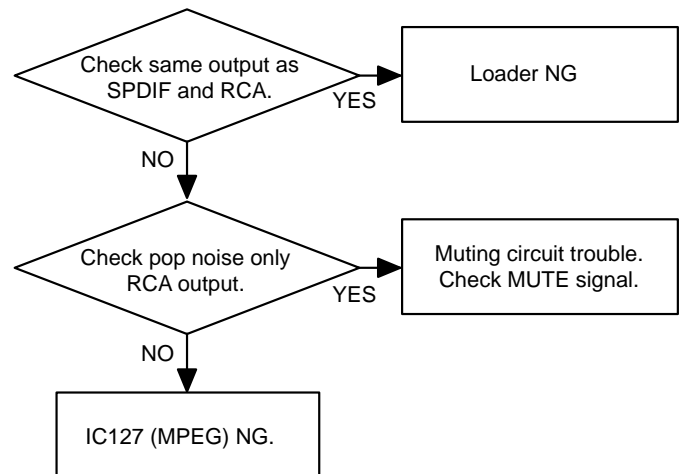

6. When pop noise (Power ON/OFF).

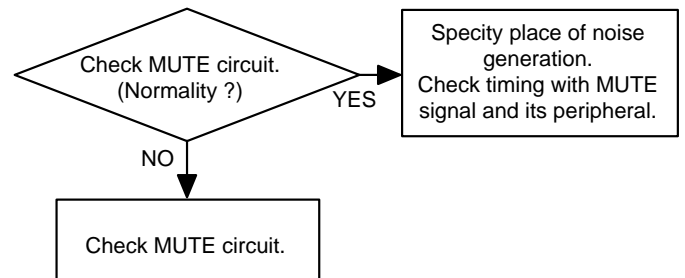

TROUBLE SHOOTING

(This is a basic trouble shooting.)

VIDEO PART

1. When sound OK and picture NG.

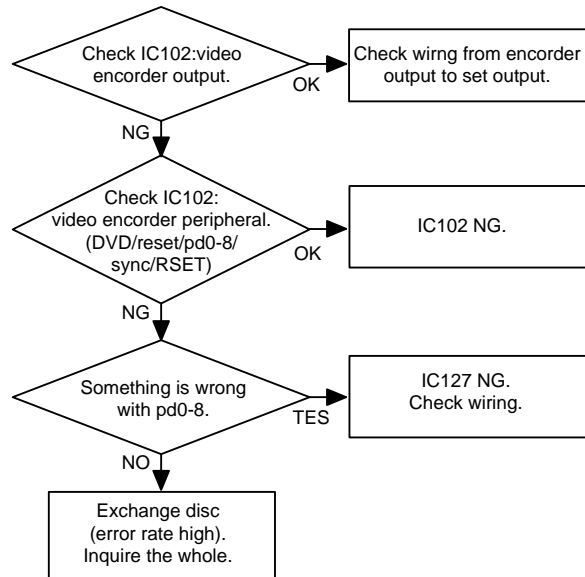

2. When sound and picture NG and display OK.

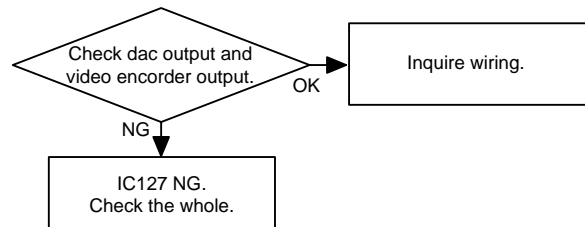

3. When confusion of the picture.

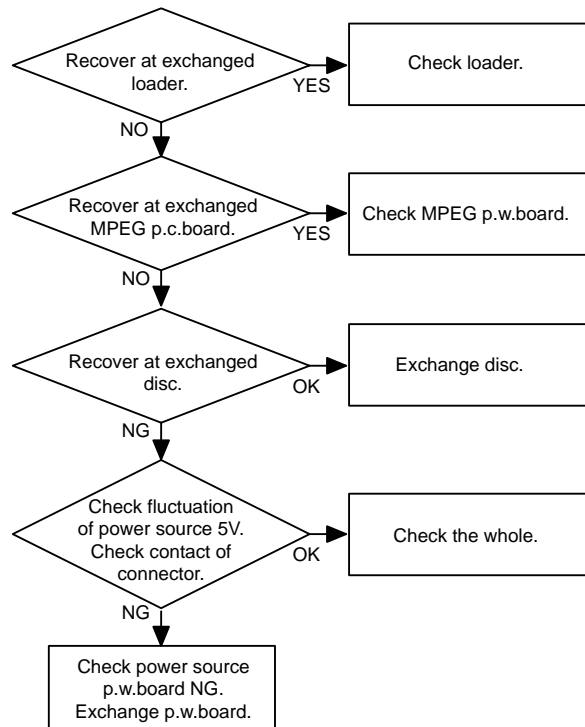

4. When confusion of the picture.

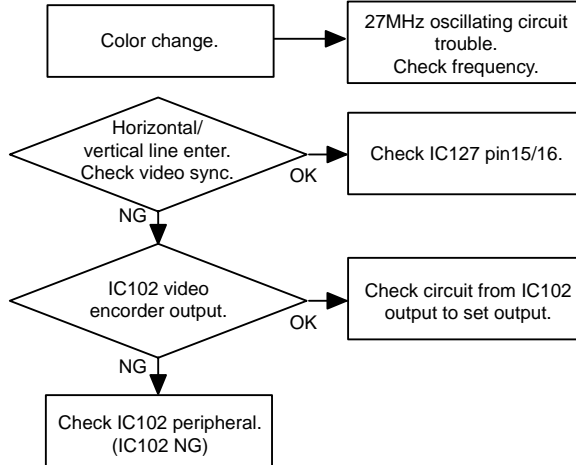

5. When color NG.

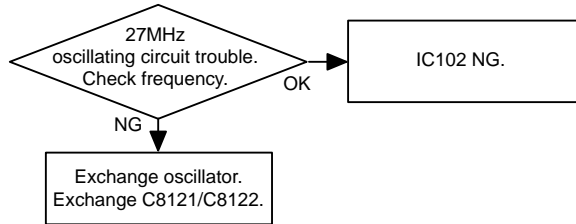

6. when not change to PAL or NTSC.

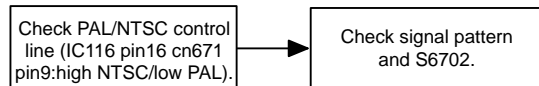

7. When s-terminal output NG and color NG.

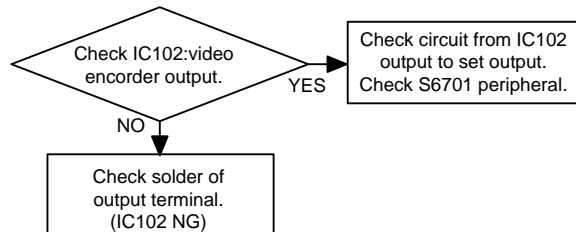

8. When YUV/RGB NG and color NG.

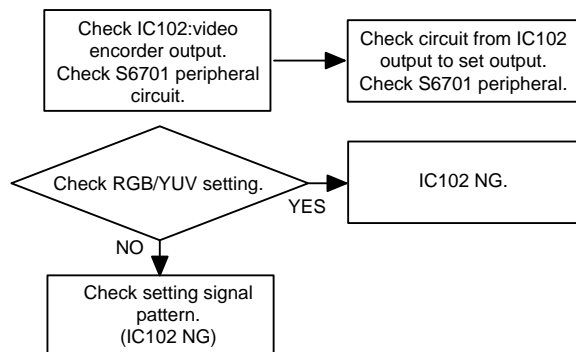

VOLTAGE OF IC & TRANSISTOR

1. MPEG part

IC101 (V)

Pin No.	1	2	3	4	5	6	7	8
Power OFF	0V	0V	0V	0V	0.1V	0.1V	0V	0.1V
Power ON	0V	0V	0V	0V	3.3V	3.3V	0V	3.3V

IC102 (V)

Pin No.	1	2	3	4	5	6	7	8	9	10	11	12	13	14	15	16
Power OFF	0.1V	0.1V	0.1V	0.1V	0.1V	0.1V	0.1V	0.1V	0.1V	0V	0.1V	0.1V	0.1V	0.1V	0.1V	0.1V
Power ON	3.3V	0.8V	0.6V	1.1V	3.3V	3.3V	3.3V	3.3V	3.3V	0V	3.3V	3.3V	3.3V	3.3V	3.3V	3.3V
Pin No.	17	18	19	20	21	22	23	24	25	26	27	28	29	30	31	32
Power OFF	0.1V	0.1V	0V	0.1V	0V	0.1V	0.1V	0.1V	0V	0V	0V	0.1V	0V	0.1V	0V	0V
Power ON	2.5V	3.3V	0V	3.3V	0V	3.3V	3.3V	3.3V	1.2V	0.8V	0.8V	3.3V	0V	3.3V	0.7V	0.4V
Pin No.	33	34	35	36	37	38	39	40	41	42	43	44				
Power OFF	0V	0V	0V	0V	0.1V	0.2V	0.1V	0.1V	0.1V	0.1V	0V	0V				
Power ON	1.2V	1.2V	0V	0V	3.2V	0.9V	0.9V	0.6V	1.3V	2.5V	0V	1.6V				

IC103 (V)

Pin No.	1	2	3
Power OFF	0.6V	0V	0V
Power ON	5.1V	0V	2.5V

IC104 (V)

Pin No.	1	2	3
Power OFF	0.6V	0V	0.1V
Power ON	5.1V	0V	3.3V

IC110 (V)

Pin No.	1	2	3	4	5	6	7	8	9	10	11	12	13	14	15	16
Power OFF	0.1V	0V	0V	0V	0V	0V	0.1V	0V	0V	0V	0V	0V	0.1V	0.1V	0.1V	0.1V
Power ON	3.3V	--	--	0V	--	--	3.3V	--	--	0V	--	--	3.3V	0V	3.3V	3V
Pin No.	17	18	19	20	21	22	23	24	25	26	27	28	29	30	31	32
Power OFF	0.1V	0.1V	0.1V	0.1V	--	--	0.5V	--	0.1V	0V	--	--	0V	0V	0.1V	0.1V
Power ON	3.1V	3.1V	0.2V	0V	0V	0V	0.2V	0.2V	3.3V	0V	0.2V	0.2V	0.2V	0.2V	0V	0V
Pin No.	33	34	35	36	37	38	39	40	41	42	43	44	45	46	47	48
Power OFF	0V	0.1V	0.1V	0.1V	0V	0.1V	0V	0V	0V	0V	0V	0.1V	0V	0V	0V	0V
Power ON	0V	3.3V	1.6V	0V	0V	3.3V	--	--	0V	--	--	3.3V	--	--	0V	--
Pin No.	49	50														
Power OFF	0V	0V														
Power ON	--	0V														

IC111 (V)

Pin No.	1	2	3	4	5	6	7	8	9	10	11	12	13	14	15	16
Power OFF	0.1V	0V	0V	0V	0V	0V	0.1V	0V	0V	0V	0V	0V	0.1V	0.1V	0.1V	0.1V
Power ON	3.3V	--	--	0V	--	--	3.3V	--	--	0V	--	--	3.3V	0V	3.3V	3V
Pin No.	17	18	19	20	21	22	23	24	25	26	27	28	29	30	31	32
Power OFF	0.1V	0V	0.1V	0.1V	--	--	--	--	0.1V	0V	0.5V	--	0.1V	0.1V	0.1V	0.1V
Power ON	3.1V	3V	0.2V	0V	0V	0V	0.2V	0.2V	3.3V	0V	0.2V	0.2V	0.2V	0.2V	0V	0V
Pin No.	33	34	35	36	37	38	39	40	41	42	43	44	45	46	47	48
Power OFF	0V	0.1V	0.1V	0.1V	0V	0.1V	0V	0V	0V	0V	0V	0.1V	0V	0V	0V	0V
Power ON	0V	3.3V	1.6V	0V	0V	3.3V	--	--	0V	--	--	3.3V	--	--	0V	--
Pin No.	49	50														
Power OFF	0V	0V														
Power ON	--	0V														

IC112 (V)

Pin No.	1	2	3	4	5	6	7	8	9	10	11	12	13	14	15	16
Power OFF	0V	0V	0V	0V	0V	0.5V	0V	2V	0V	0V	0V	0V	0.6V	0V	0V	0.019V
Power ON	0V	0.1V	3.3V	5V	3.3V	0.1V	3.3V	4.9V	0V	0V	0V	3.3V	5V	0V	5V	3.317V
Pin No.	17	18	19	20												
Power OFF	0.581V	0.020V	0V	0.092V												
Power ON	5.05V	0V	0V	3.317V												

IC113 (V)

Pin No.	1	2	3	4	5	6	7	8	9	10	11	12	13	14	15	16
Power OFF	0V	0V	0.660V	0V	0.581V	0.015V	1.204V	0.016V	1.627V	0V	0.092V	1.208V	0.011V	0.581V	0.016V	0.531V
Power ON	0V	0V	0.001V	0.001V	5.05V	0.001V	4.98V	0.018V	4.87V	0V	3.217V	0.053V	3.281V	0.039V	3.309V	0.027V

VOLTAGE OF IC & TRANSISTOR

IC113 (V)																
Pin No.	1	2	3	4	5	6	7	8	9	10	11	12	13	14	15	16
Power OFF	0V	0V	0V	0V	4.9V	0V	4.9V	0V	4.6V	0V	3.2V	0V	3.2V	0V	3.3V	0V
Power ON	0V	0V	0V	0V	4.9V	0V	4.9V	0V	4.6V	0V	3.2V	0V	3.3V	0V	3.3V	0V
Pin No.	17	18	19	20												
Power OFF	0V	0V	0V	4.9V												
Power ON	0V	0V	0V	4.9V												

IC116 (V)																
Pin No.	1	2	3	4	5	6	7	8	9	10	11	12	13	14	15	16
Power OFF	0V	2.5V	3.3V	0V	0V	0V	0V	0V	0V	0V	0V	3.3V	3.3V	3.3V	3.3V	3.3V
Power ON	0V	2.5V	3.3V	0V	0V	0V	0V	0V	0V	0V	0V	3.3V	3.3V	3.3V	0V	3.3V
Pin No.	17	18	19	20	21	22	23	24	25	26	27	28	29	30	31	32
Power OFF	3.3V	3.3V	0V	3.3V	3.3V	0V	3.3V	3.3V	3.3V	0V	0V	3.3V	0V	0V	0V	0V
Power ON	3.3V	3.3V	0V	3.3V	3.3V	0V	3.3V	3.3V	3.3V	0V	0V	3.3V	0V	0V	0V	0V
Pin No.	33	34	35	36	37	38	39	40	41	42	43	44	45	46	47	48
Power OFF	0V	0V	3.3V	3.3V	0V	3.3V	2.5V	0V	3.3V	0V	3.1V	0V	0.6V	3.1V	3.3V	2.7V
Power ON	0V	0V	3.3V	3.3V	3.3V	3.3V	2.5V	0V	3.3V	0V	3.1V	0V	--	3.2V	3.3V	2.7V
Pin No.	49	50	51	52	53	54	55	56	57	58	59	60	61	62	63	64
Power OFF	0V	0V	0V	2.5V	2.5V	0V	1.6V	3.3V	0V	3.3V	3.3V	3.3V	0V	3.3V	3.3V	3.3V
Power ON	0V	0V	0V	2.5V	2.5V	0V	1.6V	3.2V	3.3V	3.3V	3.3V	0V	0V	3.3V	3.3V	3.3V
Pin No.	65	66	67	68	69	70	71	72	73	74	75	76	77	78	79	80
Power OFF	0V	0V	0.5V	0V	0V	3.3V	3.3V	0V	0V	3.3V	3.3V	3.3V	3.3V	3.3V	3.3V	3.3V
Power ON	0V	0V	3.3V	0V	0V	0V	3.3V	0V	0V	3.3V	3.1V	3.3V	3.3V	3.3V	3.2V	3.3V
Pin No.	81	82	83	84	85	86	87	88	89	90	91	92	93	94	95	96
Power OFF	0V	2.5V	0V	3.3V	0V	0V	0V	3.3V	3.3V	3.3V	3.3V	3.3V	0V	3.3V	3.3V	0V
Power ON	0V	2.5V	3.3V	3.3V	0V	3.3V	0V	3.3V	3.3V	3.3V	3.3V	0V	3.3V	3.2V	3.3V	0V
Pin No.	97	98	99	100	101	102	103	104	105	106	107	108	109	110	111	112
Power OFF	3.3V	0V	3.3V	0V	3.3V	0.4V	0V	0.6V	0.5V	0.5V	0.6V	0.5V	0V	3.3V	0.5V	0V
Power ON	3.3V	0V	3.3V	0V	2.7V	--	--	--	--	--	--	--	0V	3.3V	--	0V
Pin No.	113	114	115	116	117	118	119	120	121	122	123	124	125	126	127	128
Power OFF	3.3V	3.3V	3.3V	3.3V	3.3V	0V	0V	3.3V	0V	2.5V	1.6V	0V	--	--	--	--
Power ON	3.3V	3.3V	3.3V	3.3V	3.3V	0V	0V	3.3V	0V	2.5V	1.6V	0V	--	--	--	--
Pin No.	129	130	131	132	133	134	135	136	137	138	139	140	141	142	143	144
Power OFF	--	0V	3.3V	--	--	0.6V	3.3V	3.3V	3.3V	3.3V	3.3V	0V	3.3V	0.1V	3.3V	0V
Power ON	--	0V	3.3V	--	--	1.1V	3.3V	3.3V	3.1V	3.1V	3.1V	0V	3.3V	0V	3.2V	0V
Pin No.	145	146	147	148	149	150	151	152	153	154	155	156	157	158	159	160
Power OFF	0V	0V	0V	0V	0V	0V	3.3V	0V	0V	0V	0V	0V	0V	0V	0V	3.3V
Power ON	0V	0V	0V	0V	0V	0V	3.3V	0V	0V	0V	0V	0V	0V	0V	0V	3.3V

IC117 (V)																
Pin No.	1	2	3	4	5	6	7	8	9	10	11	12	13	14	15	16
Power OFF	3.3V	--	--	0V	--	--	3.3V	--	0.3V	0V	0.3V	0.3V	3.3V	0V	2.1V	2.6V
Power ON	3.3V	--	--	0V	--	--	3.3V	--	--	0V	--	--	3.3V	0V	3.3V	3.2V
Pin No.	17	18	19	20	21	22	23	24	25	26	27	28	29	30	31	32
Power OFF	2.5V	11.9V	0V	0V	2.3V	2.4V	0.8V	1.7V	3.3V	0V	3.2V	1.7V	1.5V	3.1V	1.8V	0V
Power ON	3.3V	3.2V	0.2V	0.1V	3.1V	3.2V	3.1V	0V	3.3V	0V	0V	0.2V	3.3V	0V	0V	0V
Pin No.	33	34	35	36	37	38	39	40	41	42	43	44	45	46	47	48
Power OFF	0V	3.3V	1.6V	0V	0V	3.3V	--	--	0V	--	--	3.3V	--	--	0V	--
Power ON	0V	3.3V	1.6V	0V	0V	3.3V	--	--	0V	--	--	3.3V	--	--	0V	--
Pin No.	49	50														
Power OFF	--	0V														
Power ON	--	0V														

IC118 (V)																
Pin No.	1	2	3	4	5	6	7	8	9	10	11	12	13	14	15	16
Power OFF	0V	--	0V	0V	0.1V	3.2V	0V	--	3.3V	0V	0V	0V	0V	0V	0V	0V
Power ON	0.1V	--	0.1V	0.1V	0.1V	3.1V	0.1V	--	3.3V	0.1V	0V	0.1V	0.1V	3.3V	0.1V	0V
Pin No.	17	18	19	20	21	22	23	24	25	26	27	28	29	30	31	32
Power OFF	0V	--	3.1V	3.2V	0.1V	0.1V	0V	0.1V	0V	0.1V	0V	0V	--	--	--	--
Power ON	0V	0V	0V	3.3V	0V	0.1V	0V	3.3V	3.3V	3.3V	0V	3.2V	--	--	--	--
Pin No.	33	34	35	36	37	38	39	40	41	42	43	44	45	46	47	48
Power OFF	--	--	--	--	3.3V	0V	--	--	--	--	--	--	--	--	0V	0V
Power ON	--	--	--	--	3.3V	0V	--	--	--	--	--	--	--	--	0V	0.1V

VOLTAGE OF IC & TRANSISTOR

IC127 (V)																
Pin No.	1	2	3	4	5	6	7	8	9	10	11	12	13	14	15	16
Power OFF	0V	---	---	---	---	3.3V	---	---	---	---	0V	3.3V	3.3V	3.3V	3.3V	3.3V
Power ON	0V	---	---	---	---	3.3V	---	---	---	---	0V	3.3V	0V	3.3V	0V	3.3V
Pin No.	17	18	19	20	21	22	23	24	25	26	27	28	29	30	31	32
Power OFF	3.3V	3.3V	3.3V	0V	3.3V	0V	0V	3.3V	3.3V	3.3V	3.3V	0V	3.3V	3.3V	0V	0V
Power ON	0V	0V	3.3V	0V	3.3V	0V	0V	3.3V	3.3V	3.3V	3.3V	0V	3.3V	0V	0V	0V
Pin No.	33	34	35	36	37	38	39	40	41	42	43	44	45	46	47	48
Power OFF	0V	---	3.1V	3.2V	0.1V	3.2V	3.2V	3.3V	0.1V	3.3V	3.3V	3.3V	3.3V	0V	---	---
Power ON	0V	0V	3.3V	0V	3.3V	0V	0V	3.3V	0V	3.3V	3.3V	3.1V	3V	0V	---	---
Pin No.	49	50	51	52	53	54	55	56	57	58	59	60	61	62	63	64
Power OFF	---	---	---	---	---	---	0V	1.7V	0V	3.3V	0V	0V	3.3V	---	0V	3.3V
Power ON	---	---	---	---	---	---	0V	1.6V	3.3V	3.3V	0V	0V	3.3V	---	3.2V	3.3V
Pin No.	65	66	67	68	69	70	71	72	73	74	75	76	77	78	79	80
Power OFF	3.3V	0V	3.3V	3.3V	0.6V	0.7V	3.3V	0V	0V	0V	0V	0V	0V	0V	3.3V	0V
Power ON	3.3V	0V	3.3V	3.3V	3.3V	3.3V	3.3V	0V	0.5V	0.5V	0V	0.5V	0.5V	1.7V	3.3V	0V
Pin No.	81	82	83	84	85	86	87	88	89	90	91	92	93	94	95	96
Power OFF	0V	0V	0V	0V	0V	0V	3.3V	0V	0V	0V	0V	0V	3.3V	3.3V	3.3V	3.3V
Power ON	0V	0.5V	0.4V	1.5V	0V	0.7V	0.8V	0V	0V	0V	0V	0V	3.3V	1.7V	1.7V	1.7V
Pin No.	97	98	99	100	101	102	103	104	105	106	107	108	109	110	111	112
Power OFF	0V	1.1V	1.6V	0V	0V	1.6V	0V	3.3V	0V	0V	0V	0V	0V	0V	0V	0V
Power ON	0V	1.1V	1.6V	0V	0V	1.6V	1.7V	3.3V	1.6V	1.6V	0V	0V	0V	0V	1.6V	0V
Pin No.	113	114	115	116	117	118	119	120	121	122	123	124	125	126	127	128
Power OFF	0V	0V	3.3V	0V	3.3V	3.3V	---	---	0V	---	0V	---	---	---	3.3V	---
Power ON	0V	0V	3.3V	0V	3.3V	3.3V	---	---	0V	---	0V	---	---	---	3.3V	---
Pin No.	129	130	131	132	133	134	135	136	137	138	139	140	141	142	143	144
Power OFF	---	1.6V	0V	0V	0V	0V	3.3V	0V	0V	0V	0V	0V	0V	0V	3.3V	0V
Power ON	---	1.6V	0V	0V	0V	0.2	3.3V	0.2V	0.2V	0.2V	0V	0.2V	0.2V	0V	3.3V	0V
Pin No.	145	146	147	148	149	150	151	152	153	154	155	156	157	158	159	160
Power OFF	0V	0V	0V	3.3V	3.3V	3.3V	3.3V	3.3V	3.3V	0V	0V	3.3V	0V	0V	3.3V	0V
Power ON	0V	0.2V	0V	3.1V	3V	3.1V	3.3V	3V	3.3V	0V	0V	3.3V	0V	0V	3.3V	0V

IC130 (V)

Pin No.	1	2	3
Power OFF	0V	4.9V	3.3V
Power ON	0V	4.9V	3.3V

IC131

(V)

Pin No.	1	2	3	4	5	6	7	8	9	10	11	12	13	14	15	16
Power OFF	1.6V	5V	5V	0V	1V	3.3V	3.3V	3.3V	0V	0V	2.5V	0V	5V	2.5V	2.5V	0V
Power ON	1.7V	2.1V	5V	0V	1V	3.3V	3.3V	0V	3.3V	0V	2.5V	0V	5V	2.5V	2.5V	1.6V
Pin No.	17	18	19	20	21	22	23	24								
Power OFF	0V	0V	0V	1V	5V	0V	0V	0V								
Power ON	0V	1.6V	0V	0.8V	5V	0V	0V	0V								

IC132

(V)

Pin No.	1	2	3	4	5	6	7	8
Power OFF	6.6V	3.6V	3.5V	0V	3.5V	3.6V	6.6V	11.1V
Power ON	6.6V	3.6V	3.5V	0V	3.5V	3.6V	6.6V	11.1V

IC133

(V)

Pin No.	1	2	3	4	5
Power OFF	5V	5V	0V	3.3V	3.3V
Power ON	2.2V	2.2V	0V	1.7V	3.3V

IC135

(V)

Pin No.	1	2	3	4	5
Power OFF	2.4V	2.4V	0V	1.6V	3.3V
Power ON	2.4V	2.4V	0V	1.6V	3.3V

IC136

(V)

Pin No.	1	2	3	4	5
Power OFF	---	0V	0V	2.5V	3.3V
Power ON	---	---	0V	2.5V	3.3V

IC137

(V)

Pin No.	1	2	3	4	5
Power OFF	0V	0V	0V	0V	3.3V
Power ON	1.6V	1.6V	0V	1.6V	3.3V

EXPLODED VIEW (CABINET & CHASSIS)

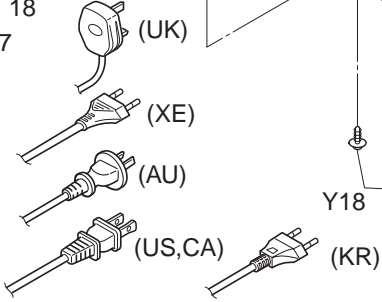
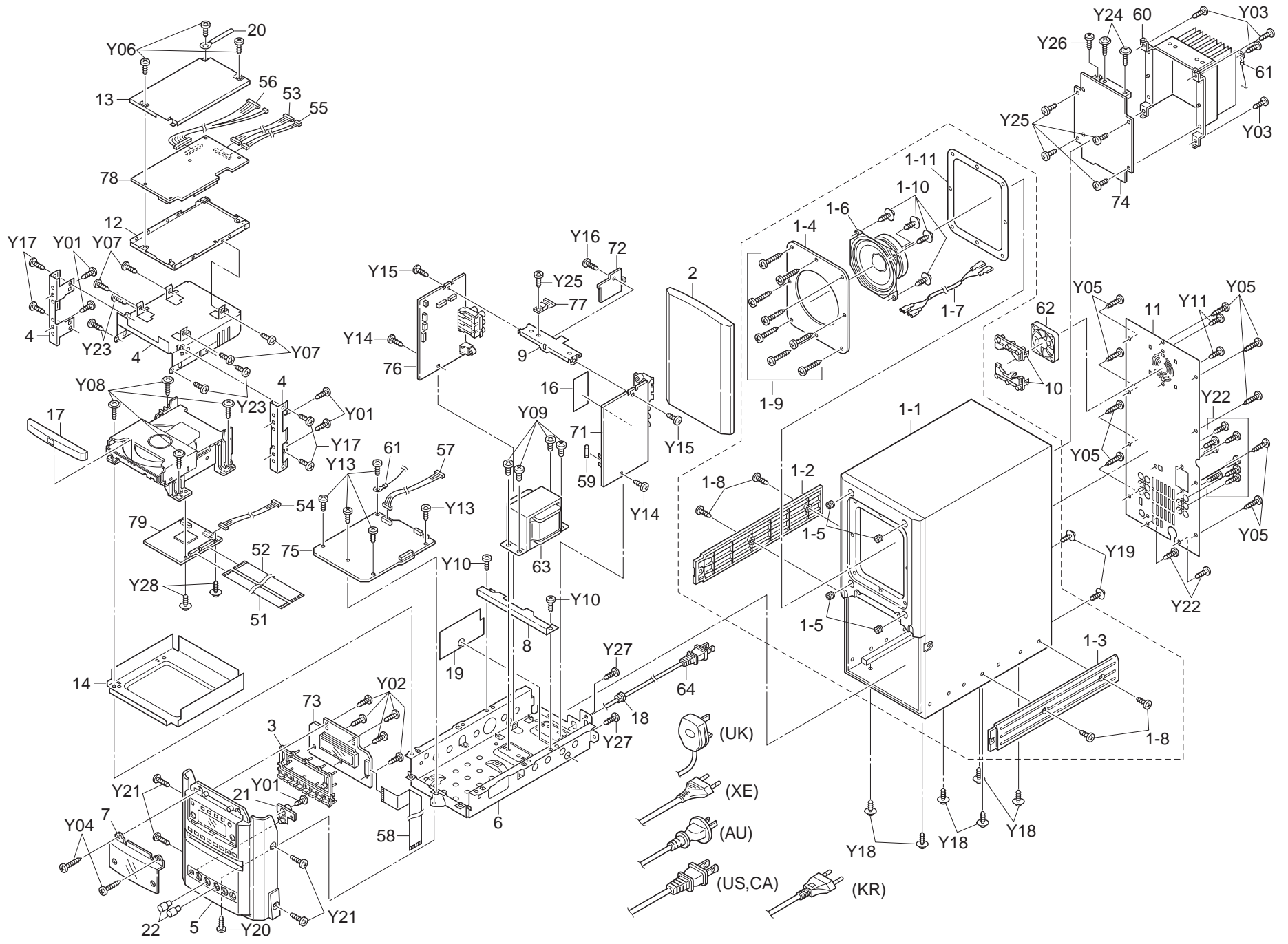

PARTS LIST

PRODUCT SAFETY NOTICE

EACH PRECAUTION IN THIS MANUAL SHOULD BE FOLLOWED DURING SERVICING. COMPONENTS IDENTIFIED WITH THE IEC SYMBOL Δ IN THE PARTS LIST AND THE SCHEMATIC DIAGRAM DESIGNATED COMPONENTS IN WHICH SAFETY CAN BE OF SPECIAL SIGNIFICANCE. WHEN REPLACING A COMPONENT IDENTIFIED BY Δ , USE ONLY THE REPLACEMENT PARTS DESIGNATED, OR PARTS WITH THE SAME RATINGS OF RESISTANCE, WATTAGE OR VOLTAGE THAT ARE DESIGNATED IN THE PARTS LIST IN THIS MANUAL. LEAKAGE-CURRENT OR RESISTANCE MEASUREMENTS MUST BE MADE TO DETERMINE THAT EXPOSED PARTS ARE ACCEPTABLY INSULATED FROM THE SUPPLY CIRCUIT BEFORE RETURNING THE PRODUCT TO THE CUSTOMER.

CAUTION : Regular type resistors and capacitors are not listed. To know those values, refer to the schematic diagram.

Regular type resistors are less than 1/4 W Carbon type and Chip type resistors.

Regular type capacitors are less than 50 V and less than 1000 μ F type of Ceramic type, Electrical type and Chip type.

PACKING & ACCESSORIES

REF.NO.	PART NO.	DESCRIPTION	REF.NO.	PART NO.	DESCRIPTION
			1-11	645 048 5169	CUSHION,MID RANGE
	614 315 8875	CARTON CASE(1000)	2	614 315 8127	ASSY,GRILLE(1000,XE,UK,SS,KR,AU)
	614 317 9689	CARTON CASE(XE)	2	614 317 3250	ASSY,GRILLE(US)
	614 317 9696	CARTON CASE(UK)	2	614 318 3648	ASSY,GRILLE(CA)
	614 318 0760	CARTON CASE(SS)	3	614 315 6611	BUTTON(1000,XE,UK,SS,KR,AU)
	614 318 6366	CARTON CASE(KR)	3	614 317 3274	BUTTON(US,CA)
	614 317 3328	CARTON CASE(US)	4	614 315 6727	MOUNTING,PANEL
	614 318 3853	CARTON CASE(CA)	5	614 315 8134	ASSY,PANEL,FRONT(1000,XE,UK,AU)
	614 318 6373	CARTON CASE(AU)	5	614 318 0708	ASSY,PANEL,FRONT(SS,KR)
	614 278 9117	NOTICE(1000,US)	5	614 317 3267	ASSY,PANEL,FRONT(US,CA)
	614 303 7484	LABEL,CAUTION,CUSHION TOP(1000)	6	614 315 6642	CHASSIS,MECHA/TRANS/PWB
	614 315 9001	INSTRUCTION,MANUAL(1000)	7	614 315 6666	DEC,WINDOW,FL
	614 317 9795	INSTRUCTION MANUAL(XE)	8	614 315 7762	HOLDER,TRANS
	614 317 9818	INSTRUCTION MANUAL(UK)	9	614 315 6734	MOUNTING,PWB,JACK PWB FIX
	614 318 0845	INSTRUCTION MANUAL(SS)	10	614 310 3837	MOUNTING,FAN
	614 318 6434	INSTRUCTION MANUAL(KR)	11	614 315 6765	PANEL,REAR(1000)
	614 317 3359	INSTRUCTION MANUAL(US)	11	614 317 5445	PANEL,REAR(XE)
	614 318 3907	INSTRUCTION MANUAL(CA)	11	614 317 5452	PANEL,REAR(UK)
	614 318 6441	INSTRUCTION MANUAL(AU)	11	614 317 5469	PANEL,REAR(SS)
	614 317 9801	INSTRUCTION MANUAL,(GREEK)(XE)	11	614 318 6182	PANEL,REAR(KR)
	614 317 3182	INSTRUCTION SHEET,QUICK GUIDE	11	614 317 3298	PANEL,REAR(US)
		(1000)	11	614 318 3679	PANEL,REAR(CA)
	614 317 3366	INSTRUCTION,SHEET,QUICK GUIDE	11	614 318 6199	PANEL,REAR(AU)
		(US)	12	614 314 7107	SHIELD,MPEG PWB BOTTOM
	614 315 8974	CUSHION, TOP	13	614 314 7114	SHIELD,MPEG PWB TOP
	614 315 8981	CUSHION,BOTTOM	14	614 315 6796	SHIELD,DVD MECHA,BOTTOM
	645 046 8278	POLY SHEET-1300X0500*NC,SET	15	614 315 6802	SHIELD,DVD MECHA, TOP
		(1000,UK,SS,KR,US,CA,AU)	16	614 307 2638	LABEL,INDICATION,FUSE(1000)
	645 047 3418	POLY SHEET-1300X0500*NC,SET(XE)	17	614 315 8110	ASSY,DEC ESCUTCHEON
	645 044 9413	REMOCON,RB-H520MT(1000,CA)			(1000,XE,UK,SS,KR,AU)
	645 044 9420	REMOCON,RB-H5201ST(XE,UK,AU)	17	614 317 3243	ASSY,DEC,ESCUTCHEON(US,CA)
	645 044 9437	REMOCON,RB-H5201(SS,KR)	18	614 129 1901	FIXER,AC CORD
	645 046 8391	REMOCON,REM-H5201(US)	or	614 284 1884	FIXER,AC CORD
	645 043 9735	BATTERY COVER,SERVICE PART	19	614 318 0166	SPACER,SHEET,CHASSIS
	645 041 1373	CABLE,VIDEO,VIDEO-CABLE(1.5M)			(1000,US,CA)
	645 047 0356	WIRE,MAIN SP	19	614 317 2994	SPACER,SHEET,CHASSIS
	645 047 0363	WIRE,SUB WOOFER			(XE,UK,SS,KR,AU)
	645 017 2175	PLUG,ADAPTOR AC(SS)	20	614 129 9136	LUG,LEAD FIX
or	645 006 4630	PLUG,ADAPTOR AC(SS)	21	614 315 6628	BUTTON,SELECT(SS,KR)
			22	614 317 5438	KNOB,ROTARY,MIC/ECHO VOL(SS,KR)
				614 317 3090	LABEL,SAFETY(XE,UK,AU)

CABINET & CHASSIS

REF.NO.	PART NO.	DESCRIPTION
1	614 315 8516	ASSY,CABINET(1000,UK,SS,KR,AU)
1	614 317 9481	ASSY,CABINET(XE)
1	614 317 3236	ASSY,CABINET(US,CA)
1-1	614 319 0523	ASSY.BOX,SPEAKER
1-2	645 048 4957	LEFT SIDE COVER
1-3	645 048 4964	RIGHT SIDE COVER
1-4	645 048 4988	MID RANGE HOLDER
1-5	645 048 4971	RUBBER CATCHER
1-6	645 048 5015	MID RANGE
1-7	645 048 5084	JOIN WIRE
1-8	645 048 5138	SCREW,SIDE COVER
1-9	645 048 5121	SCREW,MID RANGE HOLDER
1-10	645 048 5091	SCREW,MID RANGE UNIT

FIXING PARTS

REF.NO.	PART NO.	DESCRIPTION
Y01	411 021 3503	SCR S-TPG BIN 3X10, MOUNTING,PANEL
Y02	411 021 3503	SCR S-TPG BIN 3X10,FRONT PWB
Y03	645 046 8209	SCREW,HEAT SINK UNIT
Y04	645 046 8216	SCREW,PANEL FRONT SIDE
Y05	645 046 8261	SCREW,PANEL REAR
Y06	411 021 6405	SCR S-TPG BIN 3X8, MPEG PWB-SHIELD MPEG
Y07	411 021 3503	SCR S-TPG BIN 3X10,MPEG UNIT
Y08	411 020 8905	SCR S-TPG BRZ+FLG 3X10, DVD MECHA

PARTS LIST

REF.NO.	PART NO.	DESCRIPTION	REF.NO.	PART NO.	DESCRIPTION
Y09	411 001 4209	SCR S-TPG BIN 4X8,TRANS	71	614 314 5721	ASSY,PWB,SOCKET-A(Only initial) (1000,US,CA)
Y10	411 021 3503	SCR S-TPG BIN 3X10,HOLDER TRANS	71	614 318 0234	ASSY,PWB,SOCKET-A(Only initial)(SS)
Y11	411 021 3701	SCR S-TPG BIN 3X10,MOUNTING FAN	71	614 318 5529	ASSY,PWB,SOCKET-A(Only initial)(KR)
Y12	411 021 3503	SCR S-TPG BIN 3X10,FRONT PWB	71	614 318 5826	ASSY,PWB,SOCKET-A(Only initial)(AU)
Y13	411 021 3503	SCR S-TPG BIN 3X10, FRONTJACK(PRE AMP) PWB	CN429	614 315 8776	ASSY,WIRE,POWER-AUDIO (SS,KR,AU)
Y14	411 021 3503	SCR S-TPG BIN 3X10,JACK PWB L/R	CN430	614 315 8776	ASSY,WIRE,POWER-AUDIO (1000,US,CA)
Y15	411 021 3503	SCR S-TPG BIN 3X10,MOUNTING PWB	CN430	645 005 9315	PLUG,2P(SS)
Y16	411 021 3503	SCR S-TPG BIN 3X10,JACK PWB C	CN431	645 005 9315	PLUG,2P(1000,KR,US,CA,AU)
Y17	411 021 3503	SCR S-TPG BIN 3X10, FRONT ASSY-CHASSIS ASSY	CN431	645 030 9878	PLUG,3P(SS)
Y18	411 020 8905	SCR S-TPG BRZ+FLG 3X10, CHASSIS(BOTTOM SIDE)	CN432	645 045 7500	JACK,RCA-4
Y19	411 020 8905	SCR S-TPG BRZ+FLG 3X10, CHASSIS(BACK SIDE)	CN433	645 038 3670	JACK,RCA
Y20	411 021 3503	SCR S-TPG BIN 3X10, PANEL FRONT(BOTTOM SIDE)	CN434	645 011 8210	TERMINAL
Y21	411 123 9106	SCR S-TPG BIN 3X20, PANEL FRONT(L/R SIDE)	CN435	645 023 4378	SOCKET,7P
Y22	411 021 3701	SCR S-TPG BIN 3X10, PANEL REAR/ELECT PARTS	CN436	614 315 8714	ASSY,WIRE,SOCKET_A-PRE
Y23	411 021 6405	SCR S-TPG BIN 3X8, SHIELD MECHA TOP	CN437	614 315 8691	ASSY,WIRE,VIDEO-SOCKET_A
Y24	411 021 4500	SCR S-TPG BIN 3X16,POWER IC 1	CN438	614 310 2434	PLUG,2P
or	411 021 4500	SCR S-TPG BIN 3X16,POWER IC 2	or	645 005 7366	PLUG,2P
Y25	411 021 3503	SCR S-TPG BIN 3X10,POSISTOR	CN439	614 310 2298	PLUG,2P
or	411 021 3503	SCR S-TPG BIN 3X10,HEAT SINK 1	or	645 004 2683	PLUG,2P
or	411 021 3503	SCR S-TPG BIN 3X10,HEAT SINK 2	CN491	645 031 7903	HOLDER,FUSE
or	411 021 3503	SCR S-TPG BIN 3X10,HEAT SINK 3	or	645 006 4760	HOLDER,FUSE
or	411 021 3503	SCR S-TPG BIN 3X10,HEAT SINK 4	CN492	645 031 7903	HOLDER,FUSE
Y26	411 021 6405	SCR S-TPG BIN 3X8,Q4990	or	645 006 4760	HOLDER,FUSE
Y27	411 021 1806	SCR S-TPG BIN 2.6X10, VOLTAGE SELECTOR(SS)	L4300	645 031 7903	HOLDER,FUSE(SS)
			LUG43	645 006 4760	HOLDER,FUSE
			R4300	645 038 7364	INDUCTOR,70U
			or	645 023 8987	FIXER
			or	402 080 9803	CARBON 3.3M J- 1/2W
			or	402 078 8108	CARBON 3.3M J- 1/2W
			R4371	402 078 9501	CARBON 3.3M J- 1/2W
			S4399	614 241 3449	RESISTOR 0.22 K- 5W
			WR430	645 031 5800	SWITCH,SLIDE 2P-2T(SS)
			WR431	614 017 6964	TERMINAL BOARD
				614 017 6964	TERMINAL BOARD

ELECTRICAL PART

REF.NO.	PART NO.	DESCRIPTION
51	645 044 9567	FLEXIBLE FLAT CABLE (CN001) MPEG-LOADER 16P
52	645 044 9574	FLEXIBLE FLAT CABLE (CN002) MPEG-LOADER 26P
53	614 315 8653	ASSY,WIRE,POWER-MPEG (CN400)
54	614 315 8660	ASSY,WIRE,POWER-LODER (CN401)
55	614 315 8677	ASSY,WIRE,DIGITAL-MPEG (CN402)
56	614 315 8707	ASSY,WIRE,PRE-MPEG (CN404)
57	614 315 8745	ASSY,WIRE,PRE-POWER (CN406)
58	645 046 8421	FLEXIBLE FLAT CABLE,FRONT-PRE
59	△ 423 028 7002	FUSE 250V 2.5A(1000,US,CA)
59	△ 423 028 8306	FUSE250V 1.25A(XE,UK,AU)
or	△ 423 005 6509	FUSE 250V 1.25A(XE,UK,AU)
60	△ 614 315 6994	ASSY,HEAT SINK,ASSY,HEAT SINK
61	614 129 9082	LUG,POWER PWB-GND
62	645 045 6930	MOTOR,FAN DC 0.72W(Except CA)
63	△ 645 044 9635	TRANS,POWER(1000,US,CA)
63	△ 645 044 9642	TRANS,POWER(XE,UK,AU)
63	△ 645 044 9659	TRANS,POWER(SS)
63	△ 645 047 7959	TRANS,POWER(KR)
64	△ 645 037 7747	CORD,POWER-1.845MK(1000,US,CA)
or	△ 645 032 7537	CORD,POWER-1.86MK
64	△ 645 016 9939	CORD,POWER-1.74MK(XE,SS)
or	△ 614 255 2513	POWER CORD
64	△ 645 036 9797	CORD,POWER-1.6MK(UK)
or	△ 645 036 9803	POWER CORD
64	△ 645 039 2528	CORD,POWER-1.75MK(KR)
64	△ 645 032 1887	CORD,POWER-2.0MK(AU)
or	△ 614 256 5308	POWER CORD
	△ 614 086 2164	COVER,CAPACITOR(C4300)(XE,UK)

SOCKET-A P.W.BOARD ASSY

REF.NO.	PART NO.	DESCRIPTION
71	614 317 9351	ASSY,PWB,SOCKET-A,ASSY (Only initial)(XE,UK)
C4300	△ 403 349 3303	CERAMIC 0.01U M 250V
or	△ 403 366 7803	CERAMIC 0.01U M 250V
C4305	403 329 5501	ELECT 2200U M 16V
C4311	404 079 6107	ELECT 47U M 16V
CN429	614 315 8776	ASSY,WIRE,POWER-AUDIO
CN430	645 005 9315	PLUG,2P
CN431	614 315 8684	ASSY,WIRE,VIDEO-SOCKET_A
CN432	645 045 7500	JACK,RCA-4
CN433	645 038 3670	JACK,RCA
CN434	645 011 8210	TERMINAL
CN435	645 023 4378	SOCKET,7P
CN436	614 315 8714	ASSY,WIRE,SOCKET_A-PRE
CN437	614 315 8691	ASSY,WIRE,VIDEO-SOCKET_A
CN438	614 310 2434	PLUG,2P
or	645 005 7366	PLUG,2P
CN439	614 310 2298	PLUG,2P
or	645 004 2683	PLUG,2P
CN491	645 031 7903	HOLDER,FUSE
or	645 006 4760	HOLDER,FUSE
CN492	645 031 7903	HOLDER,FUSE
or	645 006 4760	HOLDER,FUSE
D4301	△ 407 097 8009	DIODE MPG06G
D4302	△ 407 097 8009	DIODE MPG06G
D4303	△ 407 097 8009	DIODE MPG06G

PARTS LIST

REF.NO.	PART NO.	DESCRIPTION
D4304	△ 407 097 8009	DIODE MPG06G
D4312	407 099 5402	ZENER DIODE MTZJ6.2B
D4313	407 012 4406	DIODE 1SS133
L4300	△ 645 038 7364	INDUCTOR,70U
LUG43	645 023 8987	FIXER
Q4310	405 141 3208	TR KTC3198-Y
or	405 141 3307	TR KTC3198-GR
or	405 019 2708	TR 2SC536-F-NP
or	405 019 3804	TR 2SC536-G-NP
Q4311	405 141 3208	TR KTC3198-Y
or	405 141 3307	TR KTC3198-GR
or	405 019 2708	TR 2SC536-F-NP
or	405 019 3804	TR 2SC536-G-NP
R4371	△ 614 241 3449	RESISTOR 0.22 K- 5W
RY430	△ 645 030 5597	RELAY,PRIMARY
or	△ 645 035 6575	RELAY,PRIMARY
T4300	△ 645 041 4954	TRANS,POWER
WR430	614 017 8203	TERMINAL BOARD
WR431	614 017 8203	TERMINAL BOARD

DIGITAL OUT P.W.BOARD ASSY

REF.NO.	PART NO.	DESCRIPTION
72	614 314 5738	ASSY,PWB,SW(Only initial) (1000,US,CA)
72	614 317 9368	ASSY,PWB,SW(Only initial)(XE,UK)
72	614 318 0241	ASSY,PWB,SW(Only initial)(SS)
72	614 318 5536	ASSY,PWB,SW(Only initial)(KR)
72	614 318 7417	ASSY,PWB,SW(Only initial)(AU)
CN420	407 218 1100	PHOTO COUPLE GP1FA550TZ
or	407 215 1608	PHOTO COUPLE TOTX178A
CN421	614 310 2458	PLUG,4P
or	645 005 8110	PLUG,4P
S4200	645 040 6119	SWITCH,SLIDE 2P-2TX2, PAL-NTSC(XE,UK,AU)

FRONT P.W.BOARD ASSY

REF.NO.	PART NO.	DESCRIPTION
73	614 314 5776	ASSY,PWB,FRONT(Only initial) (1000,US,CA)
73	614 317 9375	ASSY,PWB,FRONT(Only initial)(XE,UK)
73	614 318 0258	ASSY,PWB,FRONT(Only initial)(SS,KR)
73	614 318 5833	ASSY,PWB,FRONT(Only initial)(AU)
BR601	614 315 5843	HOLDER,FL,FL_MOUNT
CN601	645 012 5515	SOCKET,FPC 18P
CN602	614 315 8530	ASSY,WIRE
CN603	614 315 8530	ASSY,WIRE
D6001	407 012 4406	DIODE 1SS133
D6002	407 012 4406	DIODE 1SS133
D6003	407 012 4406	DIODE 1SS133
D6004	407 003 4507	DIODE DAP202K
D6850	408 044 8509	LED SLZ-9G55B-24HAB-T1
D6851	408 044 8509	LED SLZ-9G55B-24HAB-T1
D6852	408 044 8509	LED SLZ-9G55B-24HAB-T1
D6853	408 044 8509	LED SLZ-9G55B-24HAB-T1
D6870	407 115 1302	LED SLP-144B-51-A,STANDBY
DS601	407 217 1101	PHOTO DIODE SPS-442-1G,IR
FL601	645 044 8232	FLUORESCENT TUBE,FL
IC601	410 404 1006	IC LC866540A-5V28,MICON
L6000	645 001 4550	INDUCTOR,10U K
or	645 031 7835	INDUCTOR,10U K
Q6001	405 146 2107	TR KTC3875-Y
or	405 146 2206	TR KTC3875-GR
or	405 014 4509	TR 2SC2412K-R
or	405 011 1006	TR 2SC1623-L6
Q6004	405 146 5306	TR KRA102S(SS)
or	405 000 0409	TR DTA114EK
Q6006	405 146 2107	TR KTC3875-Y(SS)
or	405 146 2206	TR KTC3875-GR
or	405 014 4509	TR 2SC2412K-R
or	405 011 1006	TR 2SC1623-L6

REF.NO.	PART NO.	DESCRIPTION
S6100	645 006 5958	SWITCH,PUSH 1P-1T
S6101	645 006 5958	SWITCH,PUSH 1P-1T
S6102	645 006 5958	SWITCH,PUSH 1P-1T
S6103	645 006 5958	SWITCH,PUSH 1P-1T
S6115	645 006 5958	SWITCH,PUSH 1P-1T
S6116	645 006 5958	SWITCH,PUSH 1P-1T
S6117	645 006 5958	SWITCH,PUSH 1P-1T
S6118	645 006 5958	SWITCH,PUSH 1P-1T
S6119	645 006 5958	SWITCH,PUSH 1P-1T
S6120	645 006 5958	SWITCH,PUSH 1P-1T
X6002	645 018 6103	OSC,CERAMIC 6.000MHZ

POWER AMP P.W.BOARD ASSY

REF.NO.	PART NO.	DESCRIPTION
74	614 314 5783	ASSY,PWB,POWER(Only initial) (1000,US,CA)
74	614 317 9382	ASSY,PWB,POWER(Only initial)(XE,UK)
74	614 318 0265	ASSY,PWB,POWER(Only initial)(SS,KR)
74	614 318 5840	ASSY,PWB,POWER(Only initial)(AU)
C4705	403 057 2407	POLYESTER 0.1U J 50V
C4706	403 057 2407	POLYESTER 0.1U J 50V
C4750	403 185 0108	MT-POLYEST 0.47U J 50V
C4751	403 184 9805	MT-POLYEST 0.22U J 50V
C4805	403 057 2407	POLYESTER 0.1U J 50V
C4806	403 057 2407	POLYESTER 0.1U J 50V
C4825	403 057 2407	POLYESTER 0.1U J 50V
C4826	403 057 2407	POLYESTER 0.1U J 50V
C4900	403 329 6201	ELECT 2200U M 35V (1000,SS,KR,US,CA,AU)
C4900	△ 404 085 9505	ELECT 2200U M 35V(XE,UK)
C4901	403 329 6201	ELECT 2200U M 35V (1000,SS,KR,US,CA,AU)
C4901	△ 404 085 9505	ELECT 2200U M 35V(XE,UK)
C4910	403 329 6201	ELECT 2200U M 35V (1000,SS,KR,US,CA,AU)
C4910	△ 404 085 9505	ELECT 2200U M 35V(XE,UK)
C4914	403 326 2503	ELECT 1200U M 10V
C4918	404 079 6305	ELECT 10U M 50V(1000,US,CA)
C4924	403 337 1205	ELECT 1200U M 6.3V
CN470	614 310 2496	PLUG,8P
or	645 005 8134	PLUG,8P
CN471	614 310 2342	PLUG,7P
or	645 004 2737	PLUG,7P
CN472	614 310 2465	PLUG,5P
or	645 005 9292	PLUG,5P
CN473	614 315 8752	ASSY,WIRE,POWER-SOCKET_A
CN474	614 310 2458	PLUG,4P
or	645 005 8110	PLUG,4P
CN475	645 006 0939	PLUG,6P
or	614 310 2625	PLUG,6P
CN476	645 006 0960	PLUG,9P
or	614 310 2656	PLUG,9P
CN477	645 006 1905	PLUG,5P
D4730	407 012 4406	DIODE 1SS133
D4731	407 012 4406	DIODE 1SS133
D4750	407 012 4406	DIODE 1SS133
D4900	△ 408 043 8005	DIODE G5SBA60L-BU04
D4904	△ 407 196 5800	DIODE 1N5402BD82
D4905	△ 407 196 5800	DIODE 1N5402BD82
D4906	△ 408 044 6208	DIODE SB240L 19C2-105
D4907	△ 408 044 6208	DIODE SB240L 19C2-105
HS490	614 264 0159	HEAT SINK(XE,UK,SS,KR)
IC470	△ 409 473 9501	IC STK402-230
IC491	△ 409 499 5808	IC PQ1CZ31H2ZP,PQ1CZ31H2ZP
IC492	△ 409 463 6701	IC KIA7805API
or	△ 409 145 2809	IC NJM7805FA
IC493	△ 409 499 5808	IC PQ1CZ31H2ZP,PQ1CZ31H2ZP
L4700	614 202 1712	V.H.F COIL 1AV4L20B0320N
or	614 196 9763	V.H.F COIL

PARTS LIST

REF.NO.	PART NO.	DESCRIPTION
L4800	614 202 1712	V.H.F COIL 1AV4L20B0320N
or	614 196 9763	V.H.F COIL
L4820	614 202 1712	V.H.F COIL 1AV4L20B0320N
or	614 196 9763	V.H.F COIL
L4900	645 043 3054	INDUCTOR,10U
L4901	△ 645 045 7241	INDUCTOR,65U
L4902	645 043 3054	INDUCTOR,10U
L4904	△ 645 045 7241	INDUCTOR,65U
L4905	645 043 3054	INDUCTOR,10U
PR490	△ 645 042 2720	PROTECTOR,5A 125V
PR491	△ 645 042 2652	PROTECTOR,10A 125V
PR492	△ 645 042 2720	PROTECTOR,5A 125V
PR493	△ 645 042 2652	PROTECTOR,10A 125V
Q4700	405 143 8706	TR KTC3199-GR
or	405 017 9600	TR 2SC3330-T
or	405 017 9709	TR 2SC3330-U
or	405 011 8500	TR 2SC1740S-R
or	405 011 8609	TR 2SC1740S-S
Q4730	405 143 8706	TR KTC3199-GR
or	405 017 9600	TR 2SC3330-T
or	405 017 9709	TR 2SC3330-U
or	405 011 8500	TR 2SC1740S-R
or	405 011 8609	TR 2SC1740S-S
Q4731	405 143 6504	TR KTA1267-GR
or	405 004 4601	TR 2SA608-F-SPA
or	405 004 5103	TR 2SA608-G-SPA
or	405 006 1806	TR 2SA933S-R
or	405 006 1905	TR 2SA933S-S
Q4732	405 143 8706	TR KTC3199-GR
or	405 017 9600	TR 2SC3330-T
or	405 017 9709	TR 2SC3330-U
or	405 011 8500	TR 2SC1740S-R
or	405 011 8609	TR 2SC1740S-S
Q4733	405 143 8706	TR KTC3199-GR
or	405 017 9600	TR 2SC3330-T
or	405 017 9709	TR 2SC3330-U
or	405 011 8500	TR 2SC1740S-R
or	405 011 8609	TR 2SC1740S-S
Q4734	405 143 8706	TR KTC3199-GR
or	405 017 9600	TR 2SC3330-T
or	405 017 9709	TR 2SC3330-U
or	405 011 8500	TR 2SC1740S-R
or	405 011 8609	TR 2SC1740S-S
Q4735	405 143 8706	TR KTC3199-GR
or	405 017 9600	TR 2SC3330-T
or	405 017 9709	TR 2SC3330-U
or	405 011 8500	TR 2SC1740S-R
or	405 011 8609	TR 2SC1740S-S
Q4736	405 143 8706	TR KTC3199-GR
or	405 017 9600	TR 2SC3330-T
or	405 017 9709	TR 2SC3330-U
or	405 011 8500	TR 2SC1740S-R
or	405 011 8609	TR 2SC1740S-S
Q4737	405 143 8706	TR KTC3199-GR
or	405 017 9600	TR 2SC3330-T
or	405 017 9709	TR 2SC3330-U
or	405 011 8500	TR 2SC1740S-R
or	405 011 8609	TR 2SC1740S-S
Q4738	405 141 3208	TR KTC3198-Y
or	405 141 3307	TR KTC3198-GR
or	405 019 2708	TR 2SC536-F-NP
or	405 019 3804	TR 2SC536-G-NP
Q4739	405 143 8706	TR KTC3199-GR
or	405 017 9600	TR 2SC3330-T
or	405 017 9709	TR 2SC3330-U
or	405 011 8500	TR 2SC1740S-R
or	405 011 8609	TR 2SC1740S-S
Q4740	405 143 8706	TR KTC3199-GR
or	405 017 9600	TR 2SC3330-T
or	405 017 9709	TR 2SC3330-U

REF.NO.	PART NO.	DESCRIPTION
or	405 011 8500	TR 2SC1740S-R
or	405 011 8609	TR 2SC1740S-S
Q4741	405 143 8706	TR KTC3199-GR
or	405 017 9600	TR 2SC3330-T
or	405 017 9709	TR 2SC3330-U
or	405 011 8500	TR 2SC1740S-R
or	405 011 8609	TR 2SC1740S-S
Q4750	405 143 8706	TR KTC3199-GR
or	405 017 9600	TR 2SC3330-T
or	405 017 9709	TR 2SC3330-U
or	405 011 8500	TR 2SC1740S-R
or	405 011 8609	TR 2SC1740S-S
Q4800	405 143 8706	TR KTC3199-GR
or	405 017 9600	TR 2SC3330-T
or	405 017 9709	TR 2SC3330-U
or	405 011 8500	TR 2SC1740S-R
or	405 011 8609	TR 2SC1740S-S
Q4820	405 143 8706	TR KTC3199-GR
or	405 017 9600	TR 2SC3330-T
or	405 017 9709	TR 2SC3330-U
or	405 011 8500	TR 2SC1740S-R
or	405 011 8609	TR 2SC1740S-S
Q4910	405 146 1605	TR KRC102S
or	405 000 2908	TR DTC114EK
Q4911	405 146 1605	TR KRC102S
or	405 000 2908	TR DTC114EK
Q4912	405 146 1605	TR KRC102S
or	405 000 2908	TR DTC114EK
Q4920	405 143 8706	TR KTC3199-GR
or	405 017 9600	TR 2SC3330-T
or	405 017 9709	TR 2SC3330-U
or	405 011 8500	TR 2SC1740S-R
or	405 011 8609	TR 2SC1740S-S
R4706	△ 402 081 0403	RESISTOR 4.7 J- 2W
R4707	△ 402 081 0502	RESISTOR 330 J- 3W
R4708	△ 402 081 0403	RESISTOR 4.7 J- 2W
R4716	△ 402 081 1103	FUSIBLE RES 100 JA 1/4W
R4717	△ 402 081 1103	FUSIBLE RES 100 JA 1/4W
R4730	△ 614 241 3449	RESISTOR 0.22 K- 5W
R4799	408 017 0806	TH PTH9M04BB471TSF333
R4806	△ 402 081 0403	RESISTOR 4.7 J- 2W
R4807	△ 402 081 0502	RESISTOR 330 J- 3W
R4808	△ 402 081 0403	RESISTOR 4.7 J- 2W
R4826	△ 402 081 0403	RESISTOR 4.7 J- 2W
R4828	△ 402 081 0403	RESISTOR 4.7 J- 2W
RY470	614 224 4531	RELAY,SPEAKER
or	645 035 6582	RELAY,SPEAKER
RY480	645 046 1279	RELAY,SPEAKER
or	645 046 1743	RELAY,SPEAKER

PRE AMPLIFIER P.W.BOARD ASSY

REF.NO.	PART NO.	DESCRIPTION
75	614 315 8080	ASSY,PWB,PRE(Only initial) (1000,US,CA)
75	614 317 9399	ASSY,PWB,PRE(Only initial)(XE,UK)
75	614 318 0272	ASSY,PWB,PRE(Only initial)(SS,KR)
75	614 318 5857	ASSY,PWB,PRE(Only initial)(AU)
CN440	614 315 8738	ASSY,WIRE,POWER-PRE
CN441	645 047 2060	JACK,PHONE D3.6
CN442	645 047 2060	JACK,PHONE D3.6
CN443	645 047 2060	JACK,PHONE D3.6 (SS,KR)
CN445	614 035 4942	SOCKET,DIP 5P
CN451	614 310 2472	PLUG,6P
or	645 005 8127	PLUG,6P
CN452	614 310 2441	PLUG,3P
or	645 005 7373	PLUG,3P
CN453	645 012 5515	SOCKET,FPC 18P
CN456	614 310 2496	PLUG,8P
or	645 005 8134	PLUG,8P

PARTS LIST

REF.NO.	PART NO.	DESCRIPTION	REF.NO.	PART NO.	DESCRIPTION
CN457	614 315 8530	ASSY,WIRE,VIDEO-PRE	or	405 017 9600	TR 2SC3330-T
D4560	407 099 5303	ZENER DIODE MTZJ5.6B(SS,KR)	or	405 017 9709	TR 2SC3330-U
D4561	407 012 4406	DIODE 1SS133(SS,KR)	or	405 011 8500	TR 2SC1740S-R
D4562	407 012 4406	DIODE 1SS133(SS,KR)	or	405 011 8609	TR 2SC1740S-S
IC450	409 474 6103	IC LC75342M	Q4560	405 143 8706	TR KTC3199-GR(SS,KR)
IC451	409 478 1104	IC LA2615M,SURROUND	or	405 017 9600	TR 2SC3330-T
IC452	409 426 1804	IC KIA4558S	or	405 017 9709	TR 2SC3330-U
IC453	409 426 1804	IC KIA4558S	or	405 011 8500	TR 2SC1740S-R
IC455	409 390 8908	IC BA3838F(SS,KR)	or	405 011 8609	TR 2SC1740S-S
IC456	409 294 6109	IC TA2011S(SS,KR)	Q4561	405 143 8706	TR KTC3199-GR(SS,KR)
IC457	409 400 9505	IC BU9255FS(SS,KR)	or	405 017 9600	TR 2SC3330-T
L4401	645 001 4581	INDUCTOR,100U K(Eexcept XE,UK)	or	405 017 9709	TR 2SC3330-U
or	645 031 7842	INDUCTOR,100U K	or	405 011 8500	TR 2SC1740S-R
L4401	645 006 9864	INDUCTOR,80U(XE,UK)	or	405 011 8609	TR 2SC1740S-S
or	645 212 3171	INDUCTOR,FERITE	Q4562	405 109 9204	TR KRC102M-A(SS,KR)
L4402	645 001 4581	INDUCTOR,100U K(Eexcept XE,UK)	or	405 000 3103	TR DTC114ES
or	645 031 7842	INDUCTOR,100U K	Q4563	405 109 9204	TR KRC102M-A(SS,KR)
L4402	645 006 9864	INDUCTOR,80U(XE,UK)	or	405 000 3103	TR DTC114ES
or	645 212 3171	INDUCTOR,FERITE	Q4600	405 151 4400	TR KTD1303
L4403	645 001 4581	INDUCTOR,100U K(Eexcept XE,UK)	or	405 021 0204	TR 2SD1012-F-SPA
or	645 031 7842	INDUCTOR,100U K	or	405 021 0600	TR 2SD1012-G-SPA
L4404	645 001 4581	INDUCTOR,100U K(Eexcept XE,UK)	or	405 033 6706	TR 2SD1468S-R
or	645 031 7842	INDUCTOR,100U K	or	405 033 6805	TR 2SD1468S-S
L4451	645 001 4581	INDUCTOR,100U K(Eexcept XE,UK)	S4400	614 215 9828	SWITCH,TACT,VOCALFADER
or	645 031 7842	INDUCTOR,100U K	VR440	645 012 3054	VR,ROTARY 10KB
L4451	645 006 9864	INDUCTOR,80U(XE,UK)	VR441	645 012 3054	VR,ROTARY 10KB
or	645 212 3171	INDUCTOR,FERITE			
L4452	645 001 4581	INDUCTOR,100U K(Eexcept XE,UK)			
or	645 031 7842	INDUCTOR,100U K			
L4452	645 006 9864	INDUCTOR,80U(XE,UK)			
or	645 212 3171	INDUCTOR,FERITE			
L4453	645 001 4581	INDUCTOR,100U K(Eexcept XE,UK)			
or	645 031 7842	INDUCTOR,100U K			
L4454	645 001 4581	INDUCTOR,100U K(Eexcept XE,UK)			
or	645 031 7842	INDUCTOR,100U K			
Q4430	405 151 4400	TR KTD1303			
or	405 021 0204	TR 2SD1012-F-SPA			
or	405 021 0600	TR 2SD1012-G-SPA			
or	405 033 6706	TR 2SD1468S-R			
or	405 033 6805	TR 2SD1468S-S			
Q4480	405 151 4400	TR KTD1303			
or	405 021 0204	TR 2SD1012-F-SPA			
or	405 021 0600	TR 2SD1012-G-SPA			
or	405 033 6706	TR 2SD1468S-R			
or	405 033 6805	TR 2SD1468S-S			
Q4500	405 151 4400	TR KTD1303			
or	405 021 0204	TR 2SD1012-F-SPA			
or	405 021 0600	TR 2SD1012-G-SPA			
or	405 033 6706	TR 2SD1468S-R			
or	405 033 6805	TR 2SD1468S-S			
Q4520	405 151 4400	TR KTD1303(SS,KR)			
or	405 021 0204	TR 2SD1012-F-SPA			
or	405 021 0600	TR 2SD1012-G-SPA			
or	405 033 6706	TR 2SD1468S-R			
or	405 033 6805	TR 2SD1468S-S			
Q4531	405 143 6504	TR KTA1267-GR			
or	405 004 4601	TR 2SA608-F-SPA			
or	405 004 5103	TR 2SA608-G-SPA			
or	405 006 1806	TR 2SA933S-R			
or	405 006 1905	TR 2SA933S-S			
Q4532	405 143 8706	TR KTC3199-GR			
or	405 017 9600	TR 2SC3330-T			
or	405 017 9709	TR 2SC3330-U			
or	405 011 8500	TR 2SC1740S-R			
or	405 011 8609	TR 2SC1740S-S			
Q4535	405 143 6504	TR KTA1267-GR			
or	405 004 4601	TR 2SA608-F-SPA			
or	405 004 5103	TR 2SA608-G-SPA			
or	405 006 1806	TR 2SA933S-R			
or	405 006 1905	TR 2SA933S-S			
Q4536	405 143 8706	TR KTC3199-GR			

VIDEO P.W.BOARD ASSY

REF.NO.	PART NO.	DESCRIPTION
76	614 315 8097	ASSY,PWB,VIDEO(Only initial) (1000,US,CA)
76	614 317 9405	ASSY,PWB,VIDEO(Only initial)(XE,UK)
76	614 318 0289	ASSY,PWB,VIDEO(Only initial)(SS,KR)
76	614 318 5864	ASSY,PWB,VIDEO(Only initial)(AU)
C4112	403 325 0401	ELECT 1000U M 6.3V
C4970	403 329 6201	ELECT 2200U M 35V
C4971	403 329 6102	ELECT 1000U M 35V
CN410	614 310 2526	PLUG,11P
or	645 005 8165	PLUG,11P
CN411	645 041 1298	JACK,RCA-6)(1000,SS,KR,US,CA)
CN411	645 041 1694	JACK,RCA-3(XE,UK)
CN412	645 044 9086	SOCKET,DIN 4P
CN413	614 035 4928	SOCKET,DIP 3P
CN415	645 021 1508	SOCKET,RGB 21P(XE,UK)
CN416	614 310 2434	PLUG,2P
or	645 005 7366	PLUG,2P
CN417	614 310 2496	PLUG,8P
or	645 005 8134	PLUG,8P
CN495	645 006 0922	PLUG,5P
or	614 310 2618	PLUG,5P
CN496	645 006 0953	PLUG,8P
or	614 310 2649	PLUG,8P
CN497	614 315 8783	ASSY,WIRE,VIDEO-POWER
CN498	645 005 8226	PLUG,3P(XE,UK)
or	614 310 2595	PLUG,3P
D4101	407 218 9205	ZENER DIODE KDZ15V(XE,UK)
or	407 187 8001	ZENER DIODE UDZ10B
or	407 206 5608	ZENER DIODE UDZS10B
or	407 179 1003	ZENER DIODE UDZ15B
or	407 218 7409	ZENER DIODE UDZS15B
D4102	407 218 9205	ZENER DIODE KDZ15V(XE,UK)
or	407 187 8001	ZENER DIODE UDZ10B
or	407 206 5608	ZENER DIODE UDZS10B
or	407 179 1003	ZENER DIODE UDZ15B
or	407 218 7409	ZENER DIODE UDZS15B
D4103	407 218 9205	ZENER DIODE KDZ15V(XE,UK)
or	407 187 8001	ZENER DIODE UDZ10B
or	407 206 5608	ZENER DIODE UDZS10B
or	407 179 1003	ZENER DIODE UDZ15B
or	407 218 7409	ZENER DIODE UDZS15B

PARTS LIST

REF.NO.	PART NO.	DESCRIPTION	REF.NO.	PART NO.	DESCRIPTION
D4104	407 218 9205	ZENER DIODE KDZ15V(XE,UK)	L4100	645 034 7887	INDUCTOR,1000 OHM(XE,UK)
or	407 187 8001	ZENER DIODE UDZ10B	or	645 020 1813	INDUCTOR,1000 OHM
or	407 206 5608	ZENER DIODE UDZS10B	L4101	645 034 7887	INDUCTOR,1000 OHM(XE,UK)
or	407 179 1003	ZENER DIODE UDZ15B	or	645 020 1813	INDUCTOR,1000 OHM
or	407 218 7409	ZENER DIODE UDZS15B	LUG41	645 023 8987	FIXER
D4105	407 218 9205	ZENER DIODE KDZ15V(XE,UK)	PR410	△ 645 042 2577	PROTECTOR,0.8A 125V(XE,UK)
or	407 187 8001	ZENER DIODE UDZ10B	or	△ 645 014 2505	PROTECTOR,0.8A 125V
or	407 206 5608	ZENER DIODE UDZS10B	PR411	△ 645 027 4169	PROTECTOR,0.125A 125V
or	407 179 1003	ZENER DIODE UDZ15B	PR495	△ 645 042 2720	PROTECTOR,5A 125V
or	407 218 7409	ZENER DIODE UDZS15B	PR496	△ 645 042 2720	PROTECTOR,5A 125V
D4106	407 218 9205	ZENER DIODE KDZ15V(XE,UK)	PR497	△ 645 042 2577	PROTECTOR,0.8A 125V
or	407 187 8001	ZENER DIODE UDZ10B	or	△ 645 014 2505	PROTECTOR,0.8A 125V
or	407 206 5608	ZENER DIODE UDZS10B	PR498	△ 645 027 4169	PROTECTOR,0.125A 125V
or	407 179 1003	ZENER DIODE UDZ15B	Q4100	405 151 4400	TR KTD1303
or	407 218 7409	ZENER DIODE UDZS15B	or	405 021 0204	TR 2SD1012-F-SPA
D4107	407 218 9205	ZENER DIODE KDZ15V(XE,UK)	or	405 021 0600	TR 2SD1012-G-SPA
or	407 187 8001	ZENER DIODE UDZ10B	or	405 033 6706	TR 2SD1468S-R
or	407 206 5608	ZENER DIODE UDZS10B	or	405 033 6805	TR 2SD1468S-S
or	407 179 1003	ZENER DIODE UDZ15B	Q4101	405 151 4400	TR KTD1303
or	407 218 7409	ZENER DIODE UDZS15B	or	405 021 0204	TR 2SD1012-F-SPA
D4108	407 218 9205	ZENER DIODE KDZ15V(XE,UK)	or	405 021 0600	TR 2SD1012-G-SPA
or	407 187 8001	ZENER DIODE UDZ10B	or	405 033 6706	TR 2SD1468S-R
or	407 206 5608	ZENER DIODE UDZS10B	or	405 033 6805	TR 2SD1468S-S
or	407 179 1003	ZENER DIODE UDZ15B	Q4102	405 146 2107	TR KTC3875-Y(XE,UK)
or	407 218 7409	ZENER DIODE UDZS15B	or	405 146 2206	TR KTC3875-GR
D4109	407 218 9205	ZENER DIODE KDZ15V(XE,UK)	or	405 014 4509	TR 2SC2412K-R
or	407 187 8001	ZENER DIODE UDZ10B	or	405 011 1006	TR 2SC1623-L6
or	407 206 5608	ZENER DIODE UDZS10B	Q4120	405 146 1605	TR KRC102S(XE,UK)
or	407 179 1003	ZENER DIODE UDZ15B	or	405 000 2908	TR DTC114EK
or	407 218 7409	ZENER DIODE UDZS15B	Q4121	405 146 5306	TR KRA102S(XE,UK)
D4110	407 218 9205	ZENER DIODE KDZ15V(XE,UK)	or	405 000 0409	TR DTA114EK
or	407 187 8001	ZENER DIODE UDZ10B	Q4950	405 141 3703	TR KTA1271-Y
or	407 206 5608	ZENER DIODE UDZS10B	or	405 008 2405	TR 2SB698-F
or	407 179 1003	ZENER DIODE UDZ15B	or	405 008 2504	TR 2SB698-G
or	407 218 7409	ZENER DIODE UDZS15B	Q4951	405 146 1704	TR KTA1504-Y
D4111	407 218 9205	ZENER DIODE KDZ15V	or	405 146 9700	TR KTA1504-GR
or	407 187 8001	ZENER DIODE UDZ10B	or	405 005 5508	TR 2SA812-M6
or	407 206 5608	ZENER DIODE UDZS10B	Q4952	405 146 1704	TR KTA1504-Y
or	407 179 1003	ZENER DIODE UDZ15B	or	405 146 9700	TR KTA1504-GR
or	407 218 7409	ZENER DIODE UDZS15B	or	405 005 5508	TR 2SA812-M6
D4112	407 218 9205	ZENER DIODE KDZ15V	Q4970	405 143 6504	TR KTA1267-GR
or	407 187 8001	ZENER DIODE UDZ10B	or	405 004 4601	TR 2SA608-F-SPA
or	407 206 5608	ZENER DIODE UDZS10B	or	405 004 5103	TR 2SA608-G-SPA
or	407 179 1003	ZENER DIODE UDZ15B	or	405 006 1806	TR 2SA933S-R
or	407 218 7409	ZENER DIODE UDZS15B	or	405 006 1905	TR 2SA933S-S
D4113	407 012 4406	DIODE 1SS133(XE,UK)	Q4971	405 143 6504	TR KTA1267-GR
D4114	407 012 4406	DIODE 1SS133(XE,UK)	or	405 004 4601	TR 2SA608-F-SPA
D4954	407 012 4406	DIODE 1SS133	or	405 004 5103	TR 2SA608-G-SPA
D4955	407 012 4406	DIODE 1SS133	or	405 006 1806	TR 2SA933S-R
D4956	407 012 4406	DIODE 1SS133	or	405 006 1905	TR 2SA933S-S
D4957	407 012 4406	DIODE 1SS133	Q4973	405 143 8706	TR KTC3199-GR
D4958	407 099 9509	ZENER DIODE MTZJ30B	or	405 017 9600	TR 2SC3330-T
D4959	407 099 5204	ZENER DIODE MTZJ5.1B	or	405 017 9709	TR 2SC3330-U
D4960	407 099 4603	ZENER DIODE MTZJ3.9B	or	405 011 8500	TR 2SC1740S-R
D4961	407 012 4406	DIODE 1SS133	or	405 011 8609	TR 2SC1740S-S
D4962	407 099 6102	ZENER DIODE MTZJ10B	Q4974	405 143 8706	TR KTC3199-GR
D4963	407 012 4406	DIODE 1SS133	or	405 017 9600	TR 2SC3330-T
D4964	△ 407 097 8009	DIODE MPG06G(XE,UK)	or	405 017 9709	TR 2SC3330-U
D4965	△ 407 097 8009	DIODE MPG06G(XE,UK)	or	405 011 8500	TR 2SC1740S-R
D4966	407 012 4406	DIODE 1SS133	or	405 011 8609	TR 2SC1740S-S
D4970	△ 407 097 8009	DIODE MPG06G	Q4975	405 143 8706	TR KTC3199-GR
D4971	△ 407 097 8009	DIODE MPG06G	or	405 017 9600	TR 2SC3330-T
D4972	△ 407 098 3300	DIODE RL153-BF-S2	or	405 017 9709	TR 2SC3330-U
D4973	△ 407 098 3300	DIODE RL153-BF-S2	or	405 011 8500	TR 2SC1740S-R
D4974	407 099 4603	ZENER DIODE MTZJ3.9B	or	405 011 8609	TR 2SC1740S-S
D4975	407 099 6805	ZENER DIODE MTZJ13B	R4960	△ 402 084 7201	FUSIBLE RES 18
D4976	407 099 6805	ZENER DIODE MTZJ13B	R4970	401 105 1709	MT-GLAZE 150K JA 1/16W(XE,UK)
HS410	614 270 2598	HEAT SINK	R4971	401 105 8104	MT-GLAZE 56K JA 1/16W(XE,UK)
IC410	409 499 5907	IC MM1508XNRE,MM1508XNRE	R4974	△ 402 081 0601	RESISTOR 1K J- 2W
IC495	△ 409 463 6701	IC KIA7805API	R4975	△ 402 081 8904	RESISTOR 1 J- 1/2W
or	△ 409 145 2809	IC NJM7805FA	S4100	645 040 6102	SWITCH,SLIDE 2P-2TX4
			SH410	614 314 7176	SHIELD,SCART(XE,UK)

PARTS LIST

REF.NO.	PART NO.	DESCRIPTION	REF.NO.	PART NO.	DESCRIPTION
B8058	645 034 7887	INDUCTOR,1000 OHM	B8407	645 034 7887	INDUCTOR,1000 OHM
or	645 020 1813	INDUCTOR,1000 OHM	or	645 020 1813	INDUCTOR,1000 OHM
or	645 045 7869	IMPEDANCE,1000 OHM P	or	645 045 7869	IMPEDANCE,1000 OHM P
B8059	645 034 7887	INDUCTOR,1000 OHM	B8408	645 034 7887	INDUCTOR,1000 OHM
or	645 020 1813	INDUCTOR,1000 OHM	or	645 020 1813	INDUCTOR,1000 OHM
or	645 045 7869	IMPEDANCE,1000 OHM P	or	645 045 7869	IMPEDANCE,1000 OHM P
B8060	645 034 7887	INDUCTOR,1000 OHM	B8409	645 034 7887	INDUCTOR,1000 OHM
or	645 020 1813	INDUCTOR,1000 OHM	or	645 020 1813	INDUCTOR,1000 OHM
or	645 045 7869	IMPEDANCE,1000 OHM P	or	645 045 7869	IMPEDANCE,1000 OHM P
B8061	645 034 7887	INDUCTOR,1000 OHM	B8410	645 034 7887	INDUCTOR,1000 OHM
or	645 020 1813	INDUCTOR,1000 OHM	or	645 020 1813	INDUCTOR,1000 OHM
or	645 045 7869	IMPEDANCE,1000 OHM P	or	645 045 7869	IMPEDANCE,1000 OHM P
B8062	645 034 7887	INDUCTOR,1000 OHM	B8411	645 034 7887	INDUCTOR,1000 OHM
or	645 020 1813	INDUCTOR,1000 OHM	or	645 020 1813	INDUCTOR,1000 OHM
or	645 045 7869	IMPEDANCE,1000 OHM P	or	645 045 7869	IMPEDANCE,1000 OHM P
B8063	645 034 7887	INDUCTOR,1000 OHM	B8412	645 034 7887	INDUCTOR,1000 OHM
or	645 020 1813	INDUCTOR,1000 OHM	or	645 020 1813	INDUCTOR,1000 OHM
or	645 045 7869	IMPEDANCE,1000 OHM P	or	645 045 7869	IMPEDANCE,1000 OHM P
B8064	645 034 7887	INDUCTOR,1000 OHM	B8413	645 034 7887	INDUCTOR,1000 OHM
or	645 020 1813	INDUCTOR,1000 OHM	or	645 020 1813	INDUCTOR,1000 OHM
or	645 045 7869	IMPEDANCE,1000 OHM P	or	645 045 7869	IMPEDANCE,1000 OHM P
B8065	645 034 7887	INDUCTOR,1000 OHM	B8414	645 034 7887	INDUCTOR,1000 OHM
or	645 020 1813	INDUCTOR,1000 OHM	or	645 020 1813	INDUCTOR,1000 OHM
or	645 045 7869	IMPEDANCE,1000 OHM P	or	645 045 7869	IMPEDANCE,1000 OHM P
B8066	645 034 7887	INDUCTOR,1000 OHM	CN801	645 010 0772	PLUG,8P
or	645 020 1813	INDUCTOR,1000 OHM	CN805	645 036 4273	PLUG,14P
or	645 045 7869	IMPEDANCE,1000 OHM P	CN808	645 012 2248	PLUG,4P
B8069	645 034 7887	INDUCTOR,1000 OHM	CN809	645 041 3810	SOCKET,FPC 26P
or	645 020 1813	INDUCTOR,1000 OHM	CN810	645 041 3803	SOCKET,FPC 16P
or	645 045 7869	IMPEDANCE,1000 OHM P	CN818	645 020 7228	PLUG,9P
B8081	645 034 7887	INDUCTOR,1000 OHM	IC101	409 476 6408	IC KS24L161CS,EEPROM
or	645 020 1813	INDUCTOR,1000 OHM	or	409 339 3605	IC 24LC16BT/SN,EEPROM
or	645 045 7869	IMPEDANCE,1000 OHM P	or	410 394 0904	IC S524L50X51-SCB0,EEPROM
B8351	645 034 7887	INDUCTOR,1000 OHM	IC102	409 446 7800	IC ADV7170KSU,VIDEO_ENCODER
or	645 020 1813	INDUCTOR,1000 OHM	IC103	△ 409 482 7505	IC BA25BC0FP
or	645 045 7869	IMPEDANCE,1000 OHM P	IC104	△ 409 416 6406	IC BA033FP
B8353	645 034 7887	INDUCTOR,1000 OHM	IC105	409 408 9804	IC 74VHC74MTC,D_FRIP_FROP
or	645 020 1813	INDUCTOR,1000 OHM	or	409 415 7909	IC TC74VHC74FT,D_FRIP_FROP
or	645 045 7869	IMPEDANCE,1000 OHM P	IC110	409 482 0209	IC K4S161622D-TC80,SDRAM2MB
B8354	645 034 7887	INDUCTOR,1000 OHM	or	410 349 2502	IC EM636165TS-8,SDRAM2MB
or	645 020 1813	INDUCTOR,1000 OHM	or	410 349 2601	IC KM416S1120DT-G8,SDRAM2MB
or	645 045 7869	IMPEDANCE,1000 OHM P	or	409 482 0209	IC K4S161622D-TC80,SDRAM2MB
B8355	645 034 7887	INDUCTOR,1000 OHM	IC111	409 482 0209	IC K4S161622D-TC80,SDRAM2MB
or	645 020 1813	INDUCTOR,1000 OHM	or	410 349 2502	IC EM636165TS-8,SDRAM2MB
or	645 045 7869	IMPEDANCE,1000 OHM P	or	410 349 2601	IC KM416S1120DT-G8,SDRAM2MB
B8400	645 034 7887	INDUCTOR,1000 OHM	or	409 482 0209	IC K4S161622D-TC80,SDRAM2MB
or	645 020 1813	INDUCTOR,1000 OHM	IC112	409 431 9000	IC 74VHC244MTC
or	645 045 7869	IMPEDANCE,1000 OHM P	or	410 372 5709	IC MC74VHC244DT-R2
B8401	645 034 7887	INDUCTOR,1000 OHM	or	410 316 1804	IC TC74VHC244FT-EL
or	645 020 1813	INDUCTOR,1000 OHM	IC113	410 377 4707	IC 74VHCT244AMTC-X
or	645 045 7869	IMPEDANCE,1000 OHM P	or	410 372 5808	IC MC74VHCT244ADT-R2
B8402	645 034 7887	INDUCTOR,1000 OHM	or	410 314 3404	IC TC74VHCT244AFT-EL
or	645 020 1813	INDUCTOR,1000 OHM	IC116	409 482 0100	IC L64030,MICON
or	645 045 7869	IMPEDANCE,1000 OHM P	IC117	409 482 0209	IC K4S161622D-TC80,SDRAM2MB
B8403	645 034 7887	INDUCTOR,1000 OHM	or	410 349 2502	IC EM636165TS-8,SDRAM2MB
or	645 020 1813	INDUCTOR,1000 OHM	or	410 349 2601	IC KM416S1120DT-G8,SDRAM2MB
or	645 045 7869	IMPEDANCE,1000 OHM P	or	409 482 0209	IC K4S161622D-TC80,SDRAM2MB
B8404	645 034 7887	INDUCTOR,1000 OHM	IC118	410 368 2002	IC LE28DW8102T-90-MPB,FLASH
or	645 020 1813	INDUCTOR,1000 OHM	IC127	409 460 3307	IC L64021D,MPEG
or	645 045 7869	IMPEDANCE,1000 OHM P	IC130	409 482 0001	IC BMR-0302E,RESET
B8405	645 034 7887	INDUCTOR,1000 OHM	IC131	409 438 7504	IC PCM1723E,DAC
or	645 020 1813	INDUCTOR,1000 OHM	IC132	409 039 8603	IC NJM4560M
or	645 045 7869	IMPEDANCE,1000 OHM P	IC133	409 484 7602	IC NC7SZ08P5
B8406	645 034 7887	INDUCTOR,1000 OHM	or	409 368 5809	IC TC7SH08FU
or	645 020 1813	INDUCTOR,1000 OHM	IC135	409 484 7602	IC NC7SZ08P5
or	645 045 7869	IMPEDANCE,1000 OHM P	or	409 368 5809	IC TC7SH08FU

PARTS LIST

REF.NO.	PART NO.	DESCRIPTION
IC136	409 484 7503	IC NC7SZU04P5
or	409 330 9606	IC TC7SHU04FU
IC137	409 484 7602	IC NC7SZ08P5
or	409 368 5809	IC TC7SH08FU
L8031	645 037 1608	INDUCTOR,2.2U J
L8032	645 037 1608	INDUCTOR,2.2U J
L8033	645 037 1608	INDUCTOR,2.2U J
L8034	645 037 1608	INDUCTOR,2.2U J
Q8003	405 146 5306	TR KRA102S
or	405 000 0409	TR DTA114EK
Q8004	405 146 1605	TR KRC102S
or	405 000 2908	TR DTC114EK
X8001	645 042 2157	OSC,CRYSTAL 27.000MHZ,27MHZ_OSC

LOADER P.W.BOARD ASSY

REF.NO.	PART NO.	DESCRIPTION
79	614 316 6900	ASSY,PWB LOADER(Only initial)
CN100	645 028 6087	SOCKET,FPC 24P
CN200	645 041 3810	SOCKET,FPC 26P
CN500	645 041 3803	SOCKET,FPC 16P
CN540	645 006 0946	PLUG,7P
or	614 310 2632	PLUG,7P
CN600	645 006 0922	PLUG,5P
or	614 310 2618	PLUG,5P
CN610	645 028 8692	SOCKET,FPC 11P
CN620	645 006 2025	PLUG,2P
CN630	645 006 0908	PLUG,2P
or	614 310 2588	PLUG,2P
CN900	645 006 0939	PLUG,6P
or	614 310 2625	PLUG,6P
D1101	407 221 1807	DIODE KDS120E
or	407 179 1805	DIODE DAP222
D1102	407 221 1906	DIODE KDS121E
or	407 162 8507	DIODE DAN222
IC100	409 482 3903	IC LA9702WL-MPB
IC101	409 333 2505	IC BU4066BCF
IC200	409 500 6404	IC LC78661W-D
IC201	409 447 3702	IC T224162B-35S
or	410 367 3604	IC LC324265AT-25DV-TLM
or	409 447 3702	IC T224162B-35S
or	410 375 9407	IC LC324265AT-25DV-MPB
or	410 388 4505	IC M11B416256A-35T
IC500	409 498 8909	IC M37903S4CHP
IC502	409 183 0102	IC M51953BFP
IC504	409 330 9606	IC TC7SHU04FU
or	409 484 7503	IC NC7SZU04P5
IC550	410 337 5201	IC LE28C1001ATS-90-MPB
or	410 382 8509	IC LE28C1001DTS-90-MPB
IC601	409 484 9101	IC BA5937AFP
IC602	409 405 6301	IC BA6849FP
IC900	△ 409 416 6406	IC BA033FP
ICX01	410 399 4303	IC ASSY
L1002	645 019 0988	INDUCTOR,1000 OHM
or	645 020 2001	INDUCTOR,1000 OHM
L1003	645 019 0988	INDUCTOR,1000 OHM
or	645 020 2001	INDUCTOR,1000 OHM
L1004	645 019 0988	INDUCTOR,1000 OHM
or	645 020 2001	INDUCTOR,1000 OHM
L1005	645 019 0988	INDUCTOR,1000 OHM
or	645 020 2001	INDUCTOR,1000 OHM
L1006	645 019 0988	INDUCTOR,1000 OHM
or	645 020 2001	INDUCTOR,1000 OHM
L2002	645 019 0988	INDUCTOR,1000 OHM
or	645 020 2001	INDUCTOR,1000 OHM

REF.NO.	PART NO.	DESCRIPTION
L2003	645 019 0988	INDUCTOR,1000 OHM
or	645 020 2001	INDUCTOR,1000 OHM
L9001	645 001 5427	INDUCTOR,2.2U M
Q1002	405 014 4509	TR 2SC2412K-R
or	405 146 2206	TR KTC3875-GR
or	405 146 2107	TR KTC3875-Y
or	405 011 1006	TR 2SC1623-L6
Q1003	405 014 4509	TR 2SC2412K-R
or	405 146 2206	TR KTC3875-GR
or	405 146 2107	TR KTC3875-Y
or	405 011 1006	TR 2SC1623-L6
Q1004	405 035 5509	TR 2SA1036K-R
or	405 158 5905	TR KTA1505-Y
Q1005	405 035 5509	TR 2SA1036K-R
or	405 158 5905	TR KTA1505-Y
Q1006	405 014 4509	TR 2SC2412K-R
or	405 146 2206	TR KTC3875-GR
or	405 146 2107	TR KTC3875-Y
or	405 011 1006	TR 2SC1623-L6
Q1007	405 002 0308	TR 2SA1037K-R
or	405 146 9700	TR KTA1504-GR
or	405 134 5905	TR 2SA1037AK-R
or	405 005 5508	TR 2SA812-M6
Q1008	405 014 4509	TR 2SC2412K-R
or	405 146 2206	TR KTC3875-GR
or	405 146 2107	TR KTC3875-Y
or	405 011 1006	TR 2SC1623-L6
Q1009	405 014 4509	TR 2SC2412K-R
or	405 146 2206	TR KTC3875-GR
or	405 146 2107	TR KTC3875-Y
or	405 011 1006	TR 2SC1623-L6
Q1010	405 002 0308	TR 2SA1037K-R
or	405 146 9700	TR KTA1504-GR
or	405 134 5905	TR 2SA1037AK-R
or	405 005 5508	TR 2SA812-M6
Q1011	405 014 4509	TR 2SC2412K-R
or	405 146 2206	TR KTC3875-GR
or	405 146 2107	TR KTC3875-Y
or	405 011 1006	TR 2SC1623-L6
Q1012	405 153 2008	TR 2SK3018
Q1013	405 029 3504	TR DTC144EK
or	405 146 1407	TR KRC104S
or	405 138 6700	TR DTC144EKA
Q1015	405 014 4509	TR 2SC2412K-R
or	405 146 2206	TR KTC3875-GR
or	405 146 2107	TR KTC3875-Y
or	405 011 1006	TR 2SC1623-L6
Q1016	405 014 4509	TR 2SC2412K-R
or	405 146 2206	TR KTC3875-GR
or	405 146 2107	TR KTC3875-Y
or	405 011 1006	TR 2SC1623-L6
Q1017	405 153 2008	TR 2SK3018
Q1018	405 153 2008	TR 2SK3018
Q5020	405 014 4509	TR 2SC2412K-R
or	405 146 2206	TR KTC3875-GR
or	405 146 2107	TR KTC3875-Y
or	405 011 1006	TR 2SC1623-L6
X2000	645 020 9024	OSC,CRYSTAL 16.9344MHZ
X5000	645 045 6466	OSC,CERAMIC 16.0MHZ

PARTS LIST & EXPLODED VIEW

SPEAKER BOX

REF.NO.	PART NO.	DESCRIPTION	REF.NO.	PART NO.	DESCRIPTION
A	614 315 8622	ASSY,BOX,SPEAKER(1000)	A-10	645 048 5060	JOIN WIRE
A	614 317 9320	ASSY,BOX,SPEAKER(XE)	A-11	645 048 5077	JOIN WIRE
A	614 317 9337	ASSY,BOX,SPEAKER(UK,SS,KR,AU)	A-12	645 048 5138	SCREW,SIDE COVER
A	614 317 3229	ASSY,BOX,SPEAKER(US)	A-13	645 048 5114	SCREW,FRONT PANEL, TOP SIDE
A	614 318 3532	ASSY,BOX,SPEAKER(CA)	A-14	645 048 5121	SCREW,MID RANGE HOLDER
A-1	614 319 0516	ASSY,BOX,SPEAKER	A-15	645 048 5145	SCREW,WOOFER UNIT
A-2	645 048 4957	LEFT SIDE COVER	A-16	645 048 5091	SCREW,MID RANGE UNIT
A-3	645 048 4964	RIGHT SIDE COVER	A-17	645 048 5107	SCREW,TERMINAL BOX
A-4	645 048 4988	MID RANGE HOLDER	A-18	645 048 5183	FRONT PANEL
A-5	645 048 4995	MID RANGE BACK COVER	A-19	645 048 5152	CUSHION
A-6	645 048 5015	MID RANGE	B	614 315 8127	ASSY,GRILLE(1000,XE,UK,SS,KR,AU)
A-7	645 048 5008	WOOFER	B	614 317 3250	ASSY,GRILLE(US)
A-8	645 048 4971	RUBBER CATCHER	B	614 318 3648	ASSY,GRILLE(CA)
A-9	645 048 5046	TERMINAL BOX			

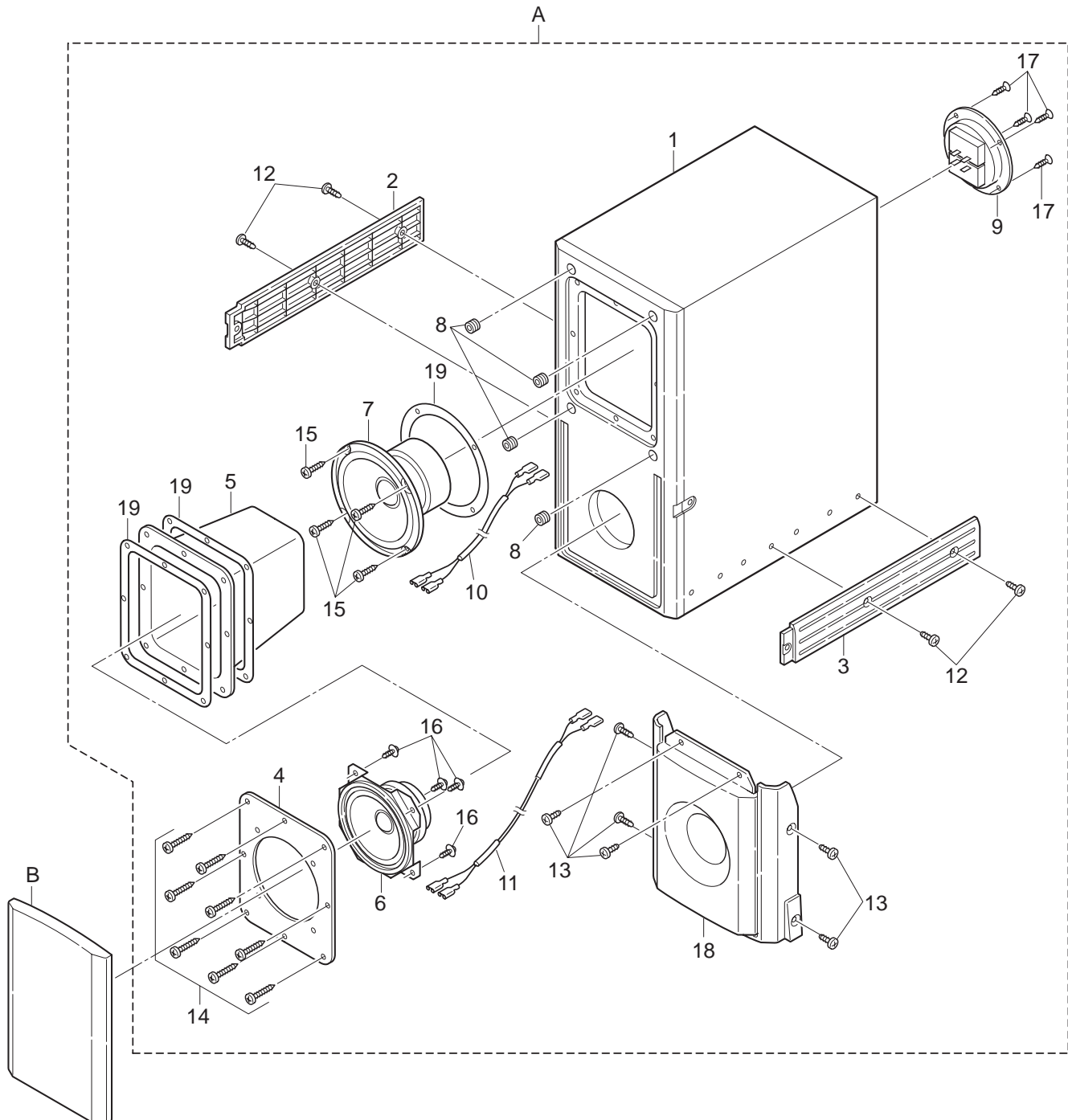

IC BLOCK DIAGRAM & DESCRIPTION

- DVD LOADER section -

IC100 LA9702WL-MPB (Front End Processor for DVD Player)

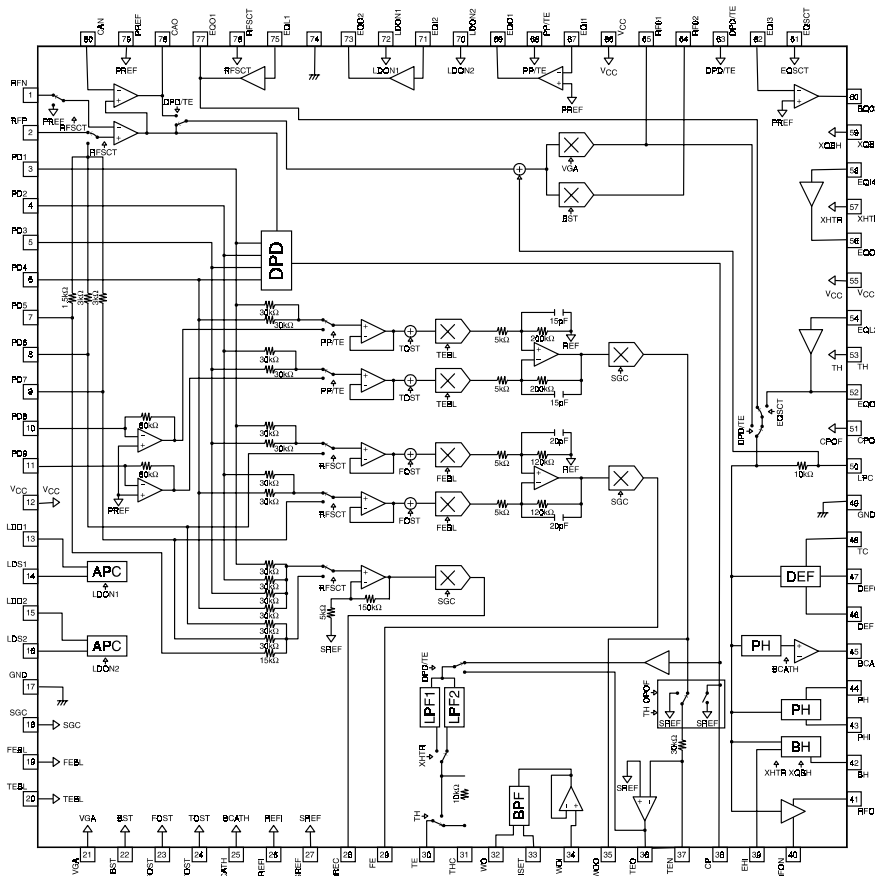

No	Name	Description
1	RFN	RF signal - input
2	RFP	RF signal + input
3	PD1	Pickup signal input
4	PD2	Pickup signal input
5	PD3	Pickup signal input
6	PD4	Pickup signal input
7	PD5	Pickup signal input
8	PD6	Pickup signal input
9	PD7	Pickup signal input
10	PD8	Pickup signal input
11	PD9	Pickup signal input
12	VCC	Power (Servo signal)
13	LDD1	APC1 output
14	LDS1	APC1 monitor voltage input
15	LDD2	APC2 output
16	LDS2	APC2 monitor voltage input
17	GND	GND. (Servo signal)
18	SGC	Servo gain control terminal (RREC, FE, TE)
19	FEBL	Focus balance adjusting terminal
20	TEBL	Tracking balance adjusting terminal
21	VGA	RF gain adjusting terminal
22	BST	Equalizer boost adjusting terminal
23	FOST	Focus offset adjusting terminal
24	TOST	Tracking offset adjusting terminal
25	BCATH	BCA threshold adjusting terminal
26	REFI	Standard voltage setting terminal
27	SREF	standard voltage output for servo signal
28	RREC	Reflection output
29	FE	Focus error output
30	TE	Tracking error output
31	THC	Condenser connection terminal to setting TE hold time constant
32	WO	Wobble output terminal
33	ISSET	Resistance connection terminal to setting BPF center frequency
34	WOI	Push-pull signal input
35	WOO	Push-pull signal output
36	TEO	TE gain setting terminal for 3 beam
37	TEN	TE gain setting terminal for 3 beam
38	CP	Resistance to setting charge pump gain, Condenser connection terminal
39	BH1	Resistance connection terminal to setting bottom hold detect parameters
40	RFON	RF - output

No.	Name	Description
41	RFOP	RF + output
42	BH	RF bottom detection output
43	PHI	Resistance connection terminal to setting peak hold detect parameters
44	PH	RF peak detect output
45	BCA	BCA output
46	DEF	Defect output (H: Defect detect)
47	DEFC	Condenser connect terminal for defect detect
48	TC	Resistance connection terminal to setting defect detect parameters
49	GND	GND. (DTP phage)
50	LPC	Condenser connection terminal for RF DC servo
51	CPOF	Charge pump OFF terminal (H: OFF)
52	EQ02	RF equalizer setting terminal
53	TH	Tracking hold (H: Hold)
54	EQL2	RF equalizer setting terminal
55	VCC	Power supply (DTP phage)
56	EQ04	RF equalizer setting terminal
57	XHTR	Tracking, Bottom detect band select (L: High band)
58	EQI4	RF equalizer setting terminal
59	XQBH	Bottom detect time constant select (L: High speed)
60	EQ03	RF equalizer setting terminal
61	EQSCT	Equalizer select (H: 77 pin selection, L: 52 pin selection)
62	EQI3	RF equalizer setting terminal
63	DPD/TE	DPD, 3 beam tracking select (H: DPD)
64	RF02	RF output
65	RF01	RF output
66	VCC	Power supply (RF phage)
67	EQI1	RF equalizer setting terminal
68	PP/TE	3 beam, push-pull tracking select (L: 3 beam)
69	EQ01	RF equalizer setting terminal
70	LDON2	APC2 Laser ON terminal (H: ON)
71	EQI2	RF equalizer setting terminal
72	LDON1	APC1 Laser ON terminal (H: ON)
73	EQ02	RF equalizer setting terminal
74	GND	GND. (RF phage)
75	EQL1	RF equalizer setting terminal
76	RFSC1	RF input select (H: RF differential input, PP error)
77	EQ01	RF equalizer setting terminal
78	CAO	Customer Amplifier output
79	PREF	Standard voltage output (for Pick-up)
80	CAN	Customer Amplifier input

IC BLOCK DIAGRAM & DESCRIPTION

IC101 BU4066BCF (Quad Analog Switch)

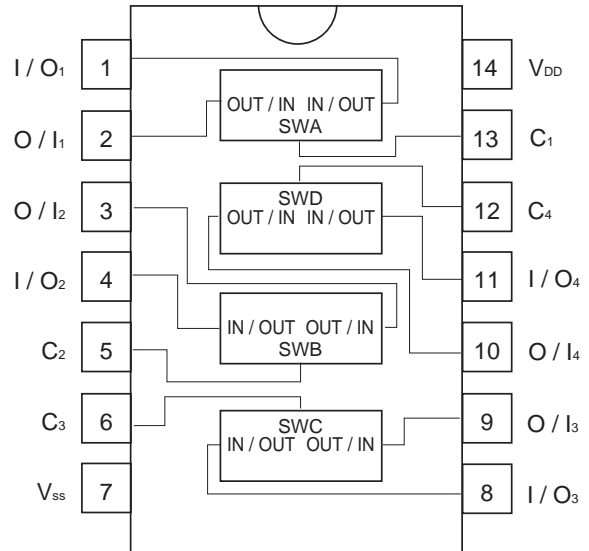

IC201 T224162B-35S (DRAM)

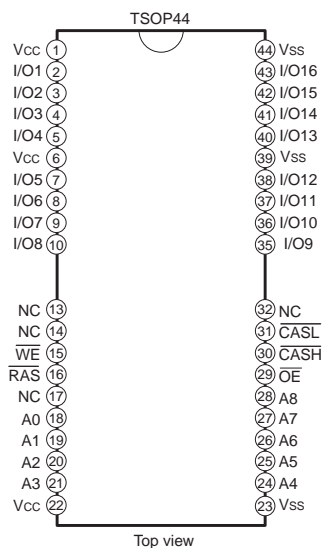
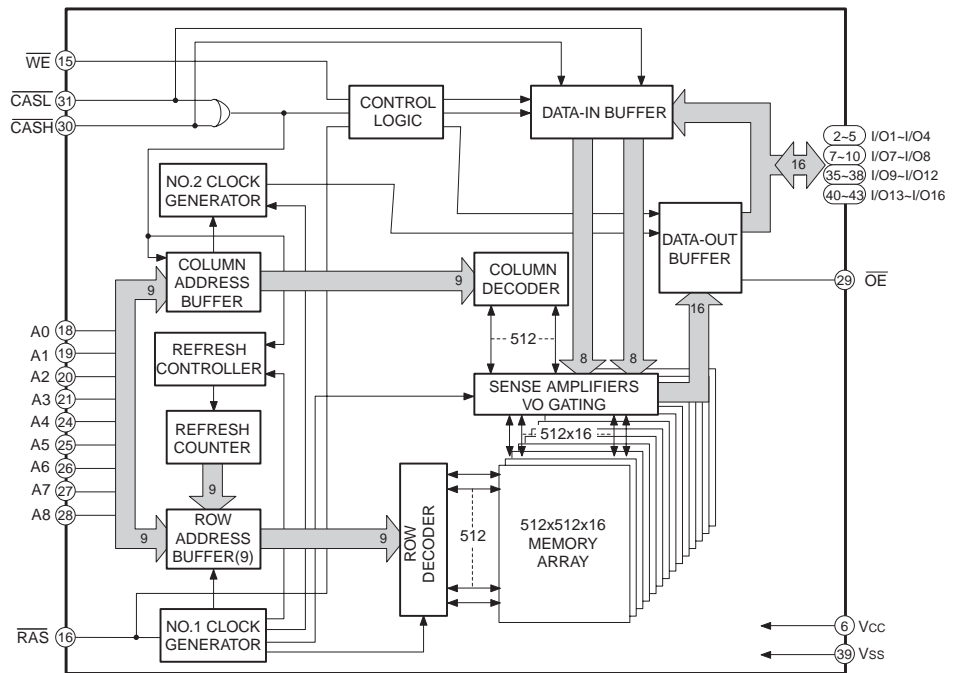

PIN NO.	SYM.	TYPE	DESCRIPTION
16-19,22-26	A0-A8	Input	Address Input
14	RAS	Input	Row Address Strobe
28	CASH	Input	Column Address Strobe /Upper Byte Control
29	CASL	Input	Column Address Strobe /Lower Byte Control
13	WE	Input	Write Enable
27	OE	Input	Output Enable
2-5,6-10,31-34,36-39	I/O1-I/O16	Input/Output	Data Input /Output
1,6,20	Vcc	Supply	Power, 5V
21,35,40	Vss	Ground	Ground
11,12,15,30	NC	-	No Connec

IC BLOCK DIAGRAM & DESCRIPTION

IC500 M37903S4CHP (16-bit Micro Computer)

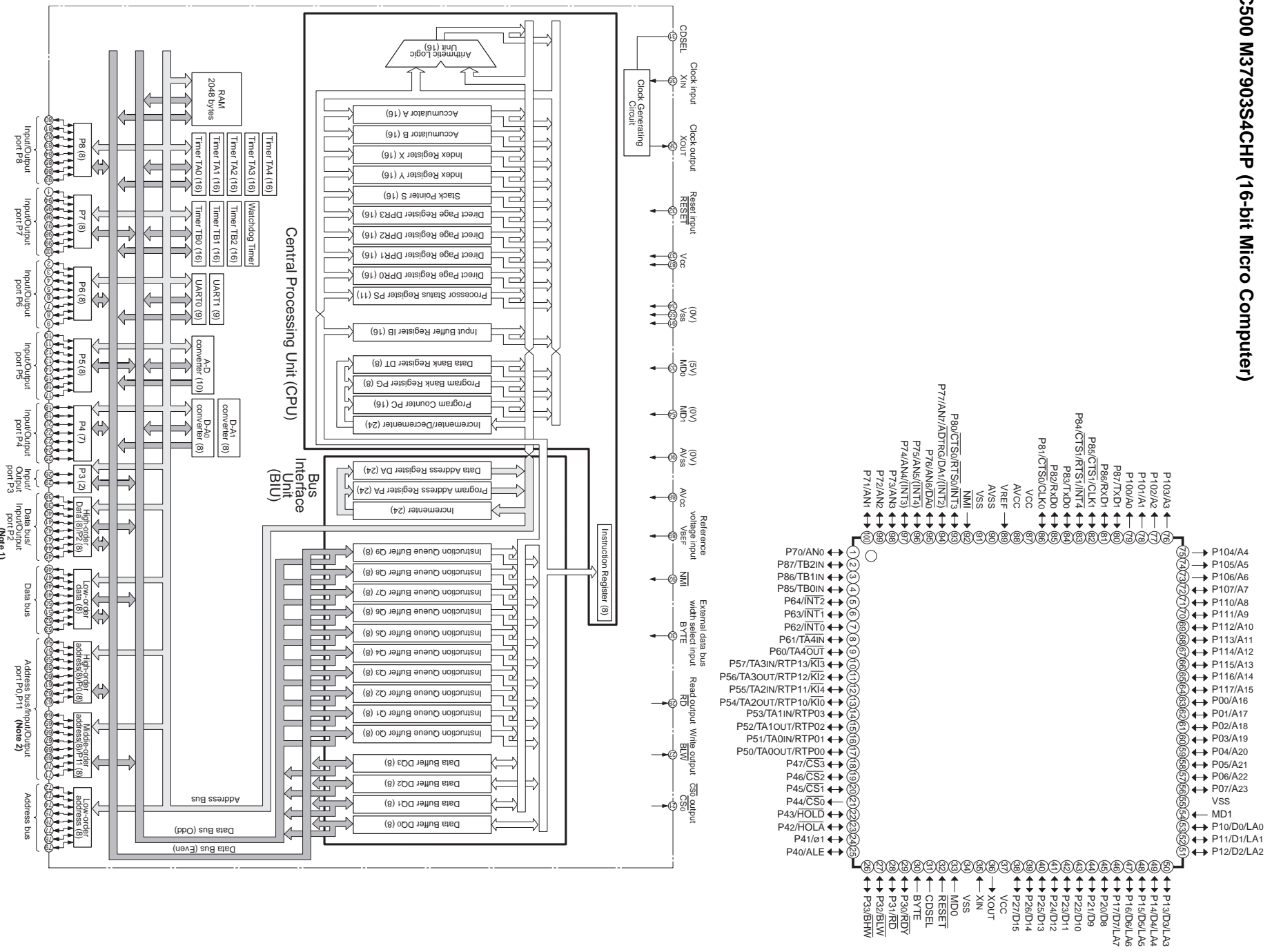

Note 1: When the external data bus width = 16 bits, this serves as the data bus; when the external data bus width = 8 bit, this serves as the IO port.
 Note 2: According to the register setting, this can serve as the IO port.

IC BLOCK DAIGRAM & DESCRIPTION

IC500 M37903S4CHP (16-bit Micro Computer)

Pin	Name	Input/ Output	Description
Vcc, Vss	Power supply input	–	Apply 5V ± 0.5V to Vcc, and 0V to Vss.
MD0	MD0	Input	Connect this pin to Vcc.
MD1	MD1	Input	Connect this pin to Vss.
RESET	Reset input	Input	The microcomputer is reset when Vss-level voltage is applied to this pin.
XIN	Clock input	Input	These are input and output pins of the internal clock generating circuit. Connect a ceramic or quartz-crystal resonator between the XIN and XOUT pins. When an external clock is used., the clock source should be connected to the XIN pin, and the XOUT pin s
XOUT	Clock output	Output	
BYTE	External data bus width select input	Input	This pin determines whether the external data bus has an 8-bit width or 16-bit width for the memory expansion mode or microprocessor mode. The width is 16 bits when Vss-level voltage is input, and 8 bits when Vcc-level voltage is applied. When BYTE=Vss level, by the resister setting, the external data bus for each of areas CS1 to CS3 can have a width of 8 bits.
CDSEL	Clock division select input	Input	This pin determines the XIN-input-clock division select bit's (note) state at reset and the input level at pin XIN.
AVcc, AVss	Analog power supply input	–	Power supply input pins for the A-D converter and the D-A converter. Connect AVcc to Vcc, and AVss to Vss externally.
VREF	Reference voltage input	Input	This is the reference voltage input pin for the A-D converter and the D-A converter.
P00/A16 - P07/A23	Address (high-order) output	Output	Address (A16-A23) is output. These pins also function as I/O port pins according to the resister setting.
P10/D0 - P17/D7	Data (low-order) I/O	I/O	The low-order 8 bits of data (D0-D7) are input /output. When the external data bus has an 8-bit width, address (LA0-LA7) output and data (D0-D7) input/output can be performed with the time-sharing method, according to the resister setting.
P20/D8 - P27/D15	I/O port p2, Data (high-order) I/O	I/O	<ul style="list-style-type: none"> ■ When 8-bit external data bus is used. Port P2 is an 8-bit I/O port. This port has an I/O direction resister, and each pin can be programmed for input or output. These pins enter the input mode at reset. ■ When 16-bit external data bus is used. The high-order 8 bits of data (D8 - D15) are input or output.
P30 - P33	I/O port P3	I/O	P30 functions as an input pin of RDY; and P31, P32, P33 function as the output pins of RD, BLW, BHW, respectively. P30 also functions as an I/O port pin according to the resister setting. When the external data has a width of 8 bits, be BHW pin functions
P40 - P47	I/O port P4	I/O	P40 - P44 function as output or input pins of ALE, φ 1, HLDA, HOLD, CS0, and P45 - P47 as I/O port pins, respectively. According to the resister setting, P40 - P43 also function as I/O port pins, and P45 - P47 as output pins of CS1 - CS3.
P50 - P57	I/O port P5	I/O	Port P5 is an 8-bit I/O port. This port has an I/O direction resister, and each pin can be programmed for input or output. These pins enter the input mode at reset. These pins also function as I/O pins for timers A0 - A3, output pins for the real-time output pins for the real-time output, and input pins for the key-input interrupt.
P60 - P67	I/O port P6	I/O	Port P6 is an 8-bit I/O port. This port has an I/O direction resister, and each pin can be programmed for input or output. These pins enter the input mode at reset. These pins also function as I/O pins for timers A4, input pins for external interrupt inputs INT0 - INT2, and input pins for timers B0 - B2.
P70 - P77	I/O port P7	I/O	Port P7 is an 8-bit I/O port. This port has an I/O direction resister, and each pin can be programmed for input or output. These pins enter the input mode at reset. These pins also function as input pins for the A-D converter, output pins for the D-A converter, and input pins for INT2, INT3, and INT4.
P80 - P87	I/O port P8	I/O	Port P8 is an 8-bit I/O port. This port has an I/O direction resister, and each pin can be programmed for input or output. These pins enter the input mode at reset. These pins also function as I/O pins for UART0, UART1, and input pins for INT3 and INT4.
P100/A0 - P107A7	Address (low-order) output	Output	Address (A0-A7) is output.
P110/A8 - P117/A15	Address (middle-order) output	Output	Address (A8-A15) is output. These pins also function as I/O port pins according to the resister setting.
NMI	Non-mask able interrupt	Input	This pin is for a non-mask able interrupt.

Note : The XIN-input-clock division select bit is used to determine whether the input clock to pin XIN is to be divided or not.

IC BLOCK DAIGRAM & DESCRIPTION

IC502 M51953BFP (Reset)

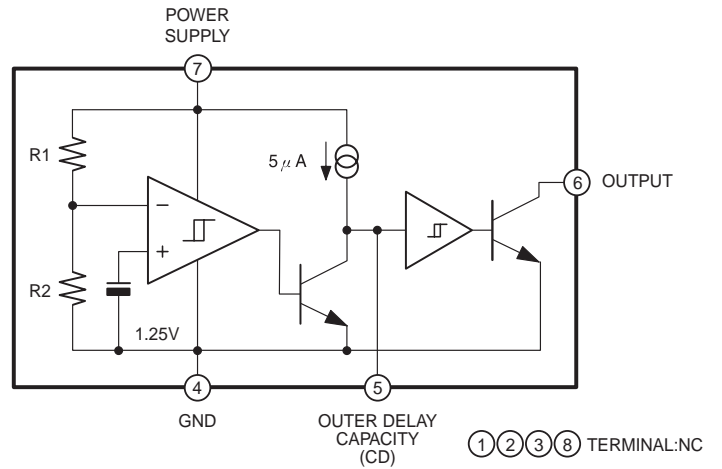
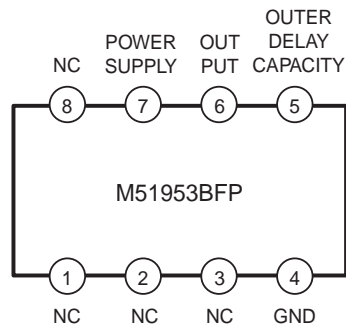

IC504 TC7SHU04FU (Inverter)

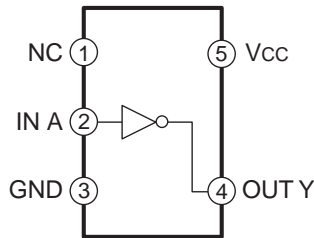

IC550 LE28C1001ATS-S-90-MPB (Flash Memory)

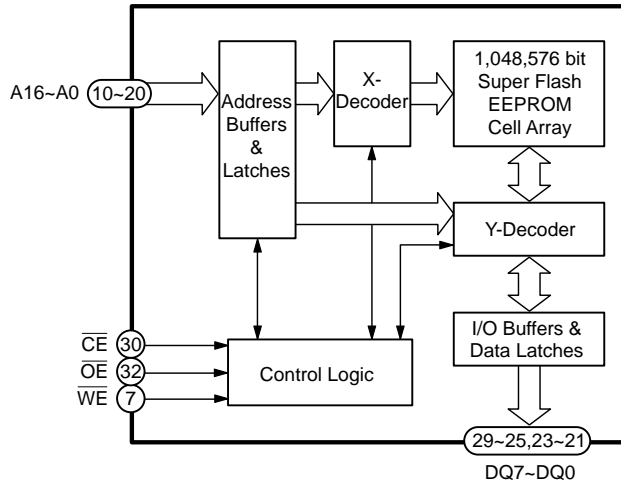

Pin Name

A16-A0	Address Inputs
DQ7-DQ0	Data Input/Output
\overline{CE}	Chip Enable
\overline{OE}	Output Enable
\overline{WE}	Write Enable
Vcc	Power Supply
Vss	Ground
NC	No Connection

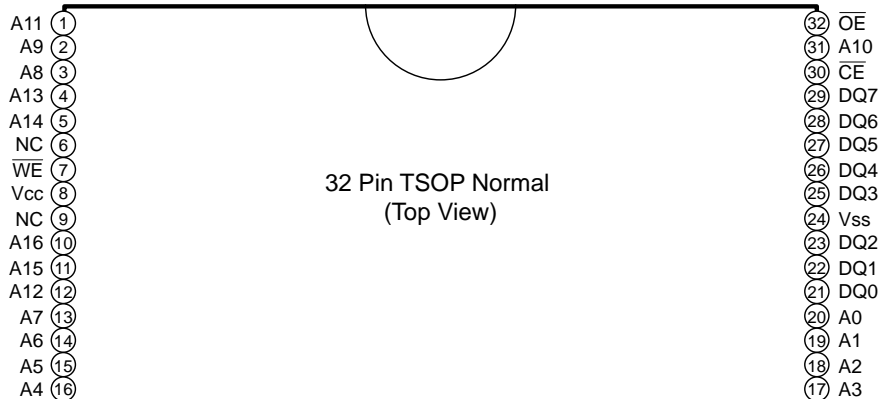

IC BLOCK DAIGRAM & DESCRIPTION

IC601 BA5937AFP (Power Driver)

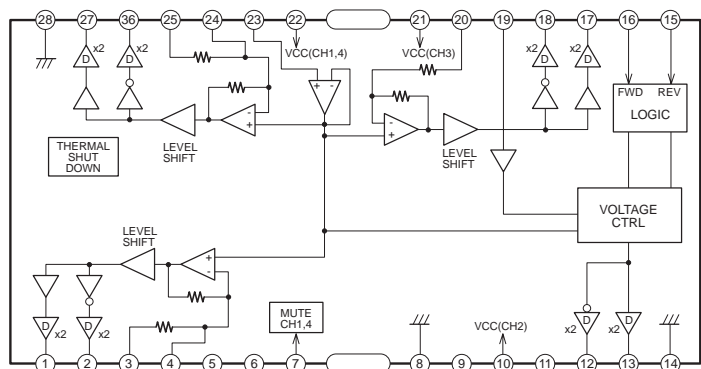

PIN NO.	NAME	DESCRIPTION	PIN NO.	NAME	DESCRIPTION
1	OUT-1	DRIVER CH1 (-)	15	REV	LOADING REV
2	OUT-2	DRIVER CH1 (+)	16	FWD	LOADING FWD
3	IN 1-1	DRIVER CH1	17	OUT3-1	DRIVER CH3 (-)
4	IN 1-2	DRIVER CH1 GAIN	18	OUT3-2	DRIVER CH3 (+)
5	NC	NOT USED	19	LD IN	LOADING
6	NC	NOT USED	20	IN 3	DRIVER CH3
7	MUTE	CH1,4 MUTE CONTROL	21	VCC3	VCC(CH3)
8	GND		22	VCC1	VCC(CH1,4)
9	NC	NOT USED	23	Vref IN	BIAS
10	VCC2	VCC(CH2)	24	IN 4-2	DRIVER CH4 GAIN
11	NC	NOT USED	25	IN 4-1	DRIVE CH4
12	OUT2-2	DRIVER CH2 LOADING (+)	26	OUT4-2	DRIVER CH4 (+)
13	OUT2-1	DRIVER CH2 LOADING (-)	27	OUT4-1	DRIVER CH4 (-)
14	GND	SUB STRAIGHT GND	28	GND	SUB STRAIGHT GND

IC602 BA6849FP (CD-ROM Motor Driver)

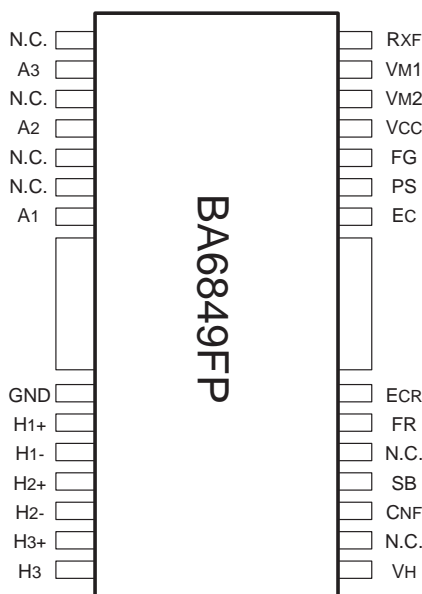
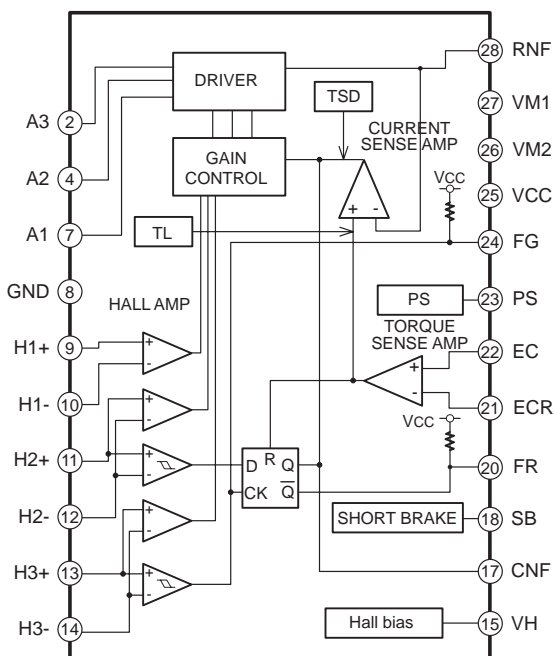

Pin No.	Name	Description	Pin No.	Name	Description
1	N.C.		15	VH	Hall vias
2	A3	Output	16	N.C.	
3	N.C.		17	CNF	Phase compensation condenser
4	A2	Output	18	SB	Short brake
5	N.C.		19	N.C.	
6	N.C.		20	FR	Rotation detection
7	A1	Output	21	ECR	Output voltage control reference
8	GND	GND	22	EC	Output voltage control
9	H1+	Hall signal input	23	PS	Power save
10	H1-	Hall signal input	24	FG	FG signal output
11	H2+	Hall signal input	25	VCC	Power source
12	H2-	Hall signal input	26	VM2	Motor power source 2
13	H3+	Hall signal input	27	VM1	Motor power source 1
14	H3-	Hall signal input	28	RNF	Resistance(output current detection) connect

IC900 BA033FP (Regulator)

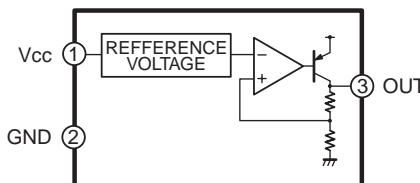
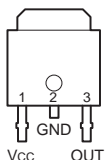

IC BLOCK DAIGRAM & DESCRIPTION

- FRONT section -

IC601 LC866540A (Micro Computer)

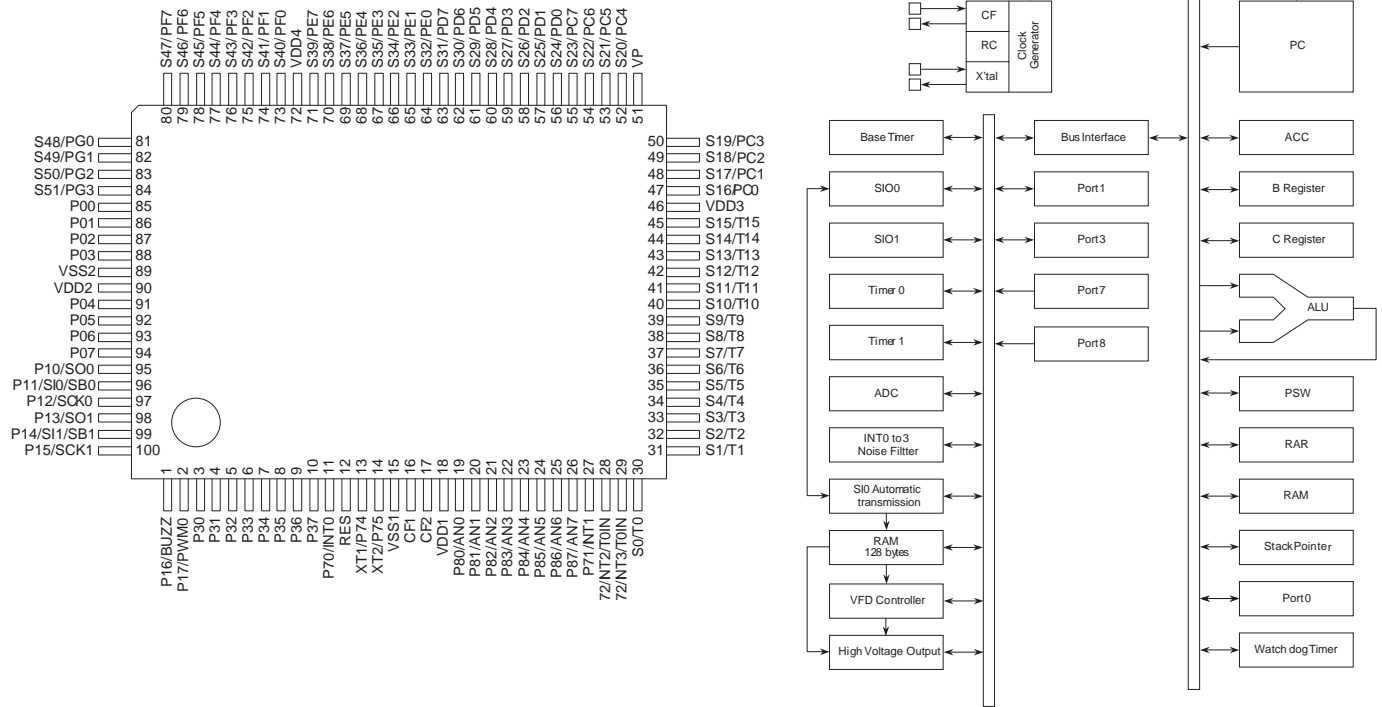

Pin Name	I/O	Function Description	Pin Name	I/O	Function Description
VSS1,2		Power pin (-) * 1	S7/T7 to S15/T15	O	* Output for VFD display controller segment/timing with internal pull-down resistor in common. * Internal pull-down resistor output
VDD1,2,3,4		Power pin (+) * 1	S16 to S31	I/O	* Output for VFD display controller segment * Other function S16 ~ S23 : High voltage input port PC0 ~ PC7 S24 ~ S31 : High voltage input port PD0 ~ PD7
VP		Power pin (+) for the VFD output pull-down resist	S32 to S47		* Output for VFD display controller segment * Other function S32 ~ S39 : High voltage input port PE0 ~ PC7 S40 ~ S47 : High voltage I/O port PF0 ~ PD7
P00 - P07	I/O	* 8-bit input/output port Input/output port * Input for port 0 interrupt * Inout for HOLD release * 15V withstand at N-channel open drain output	S48 to S51		* Output for VFD display controller segment * Other function S48 ~ S51 : High voltage I/O port PG0 ~ PD3
P10 - P17	I/O	* 8-bit input/output port Input/output can be specified in bit unit * Other pin functions P10 : SIO0 data output P11 : SIO0 data input/bus input/output P12 : SIO0 clock input/output P13 : SIO1 data output P14 : SIO1 data input/bus input/output P15 : SIO1 clock input/output P16 : Buzzer output P17 : Timer output (PWM0 output)	RES	I	Reset pin
P30 - P37	I/O	* 8-bit input/output port Input/output in bit unit * 15V withstand at N-channel open drain output	XT1/P74	I	* Input pin for 32.768kHz crystal oscillation * Other function P74 for input port In case of non use, connect to VDD1
P70 - P73	I/O	* 4-bit input/output port	XT2/P75	O	* Output pin for 32.768kHz crystal oscillation * Other function P75 for input port * In case of non use, At using as oscillator, should be left opened At using as a port, connect to VDD1
P74 - P75	I	Input/output port * 2-bit input port * Other pin functions P70 : INT0 input/Hold release/N ch-Tr. output for watchdog timer P71 : INT1 input/ HOLD release input P72 : INT2 input/timer 0 event input P73 : INT3 input with noise filter/timer 0 event input P74 : Input pin XT1 for 32.768kHz crystal resonator oscillation P75 : Output pin XT2 for 32.768kHz crystal resonator oscillation	CF1	I	Input pin for ceramic resonator oscillation
P80 - P83	I	* 4-bit input/output port	CF2	O	Output pin for ceramic resonator oscillation
P84 - P87	I/O	Input/output in bit unit * 4-bit input port * Other function AD input port (8 port pins)			
S0/T0 to S6/T6	O	Output for VFD display controller segment/timing in common			

* All of port options (except pull-up resistor of port 0) can be specified in bit unit.
* A state of pins at reset

IC BLOCK DAIGRAM & DESCRIPTION

- POWER section -

IC470 STK402-230 (3 Channel AF Power Amplifier)

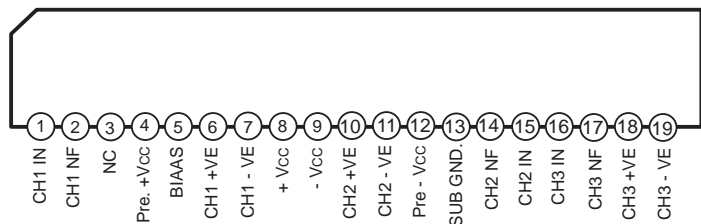

IC491,493 PQ1CZ31H2ZP (Chopper Regulator)

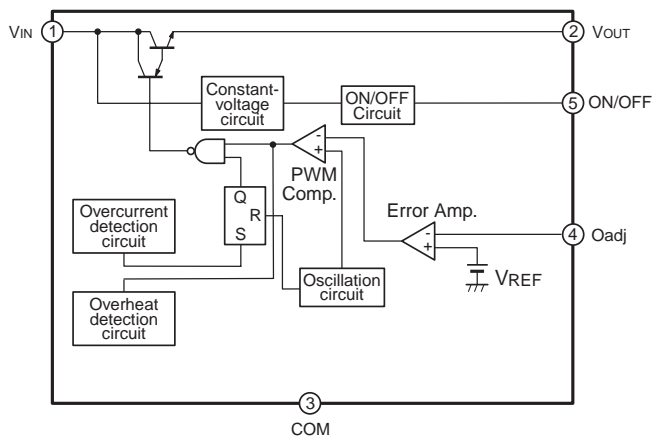

IC492 NJM7805FA, KIA7805API (Regulator)

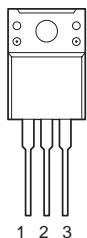

1. INPUT
2. COMMON
3. OUTPUT

- PRE-AMP section -

IC450 LC75342M (2 Band Equalizer)

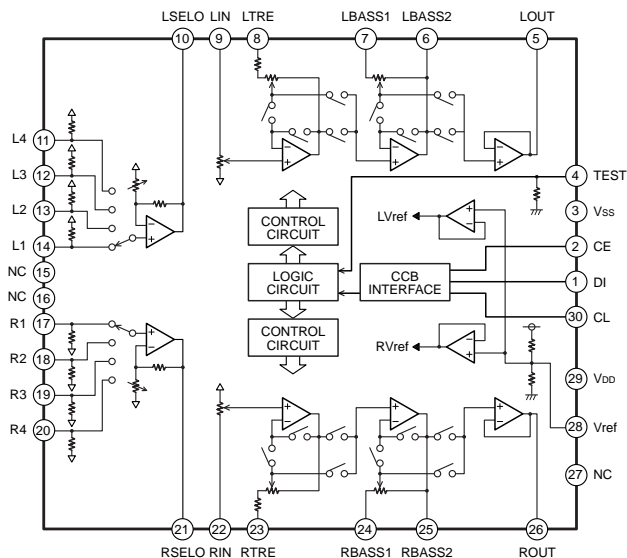

IC451 LA2615 (Surround Signal Processor)

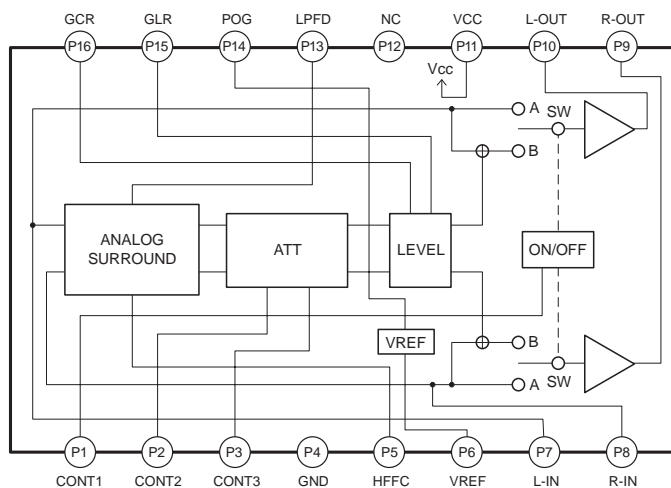

IC452, 453 KIA4558S (Operational Amplifier)

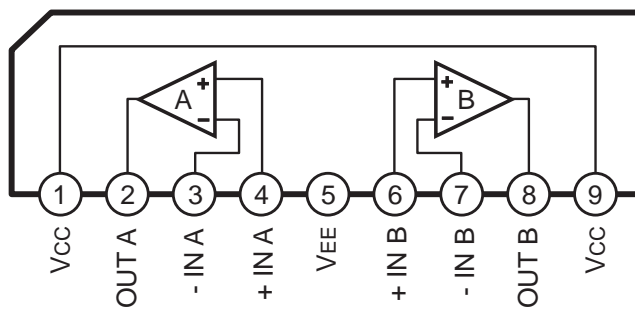

IC BLOCK DAIGRAM & DESCRIPTION

- VIDEO section -

IC410 MM1508XNRE (2-Input 1-Output Switch with 6dB AMP)

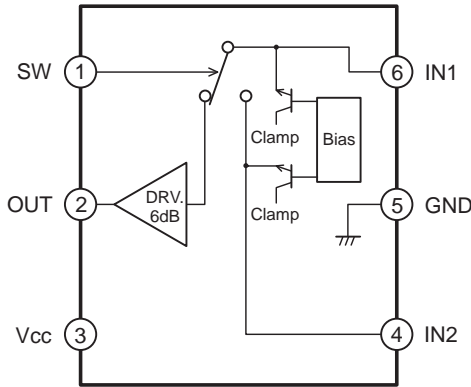

IC495 NJM7805FA, KIA7805API (Regulator)

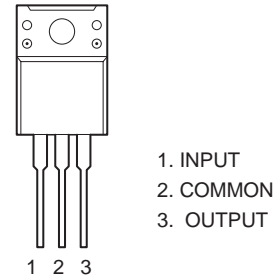

- MPEG section -

IC101 24LC16BT, S524L50X51 (16K EEPROM)

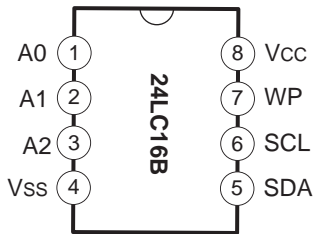

Name	Function
Vss	Ground
SDA	Serial Address/Data I/O
SCL	Serial Clock
WP	Write Protect Input
Vcc	+2.5V to 5.5V Power Supply
A0,A1,A2	No Internal Connection

IC104 BA033FP (Regulator)

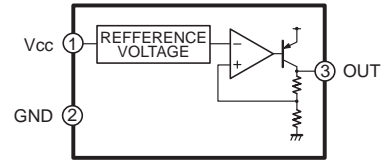
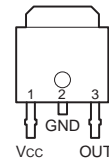

IC103 BA25BCOFP (Voltage Regulator)

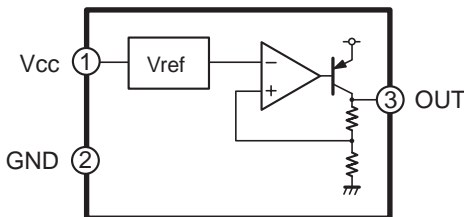

IC105 74VHC74MTC, TC74VHC74FT (Flip-Flop)

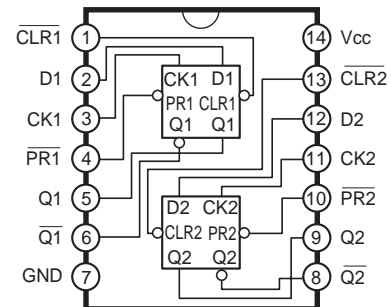

Truth Table

Inputs				Output		Function
CLR	PR	D	CK	Q	\bar{Q}	
L	H	X	X	L	H	Clear Preset
H	L	X	X	H	L	
L	L	X	X	H(Note 1) H(Note 1)		No Change
H	H	L	\nearrow	L	H	
H	H	H	\nearrow	H	L	
H	H	X	\searrow	Qn	Qn	

IC BLOCK DAIGRAM & DESCRIPTION

IC102 ADV7170KSU (VIDEO Encoder)

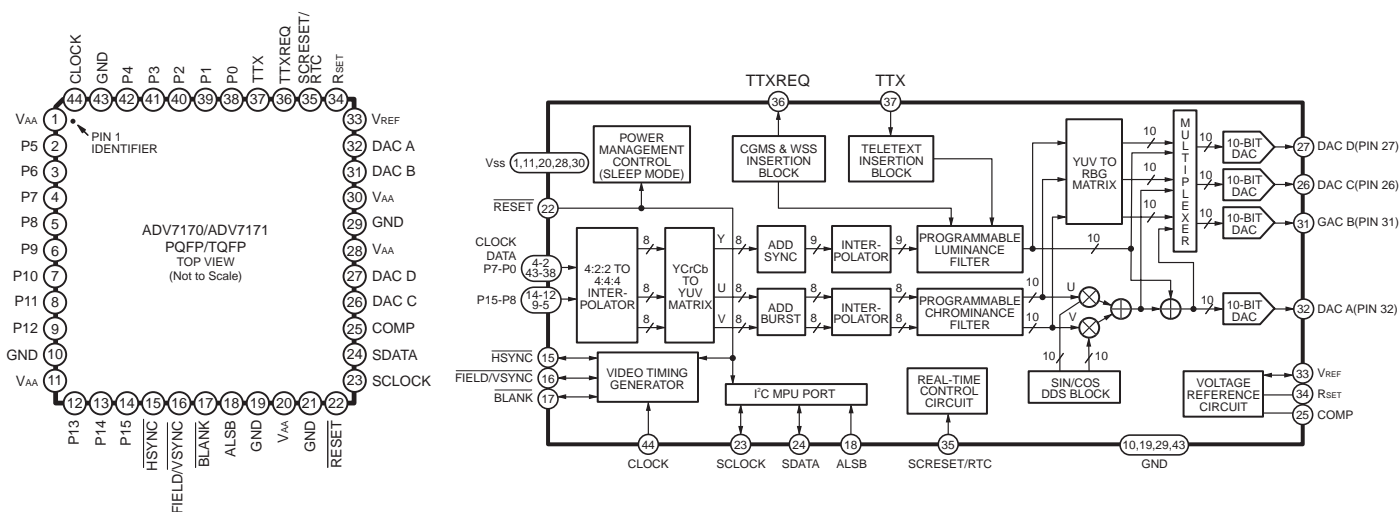

Mnemonic	Input/Output	Function
P15-P0	I	8-Bit 4:2:2 Multiplexed YCrCb Pixel Port (P7-P0) or 16-Bit YCrCb Pixel Port (P15-P0). P0 represents the LSB.
CLOCK	I	TTL Clock Input. Requires a stable 27 MHz reference Clock for standard operation. Alternatively, a 24.52 MHz (NTSC) or 29.5 MHz (PAL) can be used for square pixel operation.
HSYNC	I/O	HSYNC (Modes 1 and 2) Control Signal. This pin may be configured to output (Master Mode) or accept (Slave Mode) Sync signals.
FIELD/VSYNC	I/O	Dual Function FIELD (Mode 1) and VSYNC (Mode 2) Control Signal. This pin may be configured to output (Master Mode) or accept (Slave Mode) these control signals.
BLACK	I/O	Video Blanking Control Signal. The pixel inputs are ignored when this is Logic Level "0." This signal is optional.
SCRESET/RTC	I	This pin can be configured as an input by setting MR22 and MR21 of Mode Register 2. It can be configured as a subcarrier reset pin, in which case a high-to-low transition on this pin will reset the subcarrier to Field 0. Alternatively, it may be configured as a Real-Time Control (RTC) input.
VREF RSET	I/O I	Voltage Reference Input for DACs or Voltage Reference Output (1.235 V). A 150 Ω resistor connected from this pin to GND is used to control full-scale amplitudes of the video signals.
COMP	O	Compensation Pin. Connect a 0.1 μ F Capacitor from COMP to VAA. For Optimum Dynamic Performance in low power mode, the value of the COMP capacitor can be lowered to as low as 2.2 nF.
DAC A	O	PAL/NTSC Composite Video Output. Full-Scale Output is 180 IRE (1286 mV) for NTSC and 1300 mV for PAL.
DAC C	O	RED/S-Video C/V Analog Output.
DAC D	O	GREEN/S-Video Y/Y Analog Output.
DAC B	O	BLUE/Composite/U Analog Output.
SCLOCK	I	MPU Port Serial Interface Clock Input.
SDATA	I/O	MPU Port Serial Data Input/Output.
ALSB	I	TTL Address Input. This signal set up the LSB of the MPU address.
RESET	I	The input resets the on chip timing generator and sets the ADV7170/ADV7171 into default mode. This is NTSC operation, Timing Slave Mode 0, 8 Bit Operation, 2 x Composite and S Video out and DAC B powered ON and DAC D powered OFF.
TTX/VAA	I	Teletext Data/Defaults to VAA When Teletext not Selected (enables backward compatibility to ADV7175/ADV7176).
TTXREQ/GND	O	Teletext Data Request Signal/ Defaults to GND when Teletext not Selected (enables backward compatibility to ADV7175/ADV7176).
VAA	P	Power Supply (+3V to +5V).
GND	G	Ground Pin.

IC BLOCK DAIGRAM & DESCRIPTION

IC110,111,117 EM636165TS, KM416S1120DT, K4S161622D IC130 BMR-0302E (Reset) (1 Mega x 16 Synchronous DRAM)

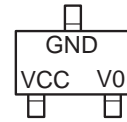
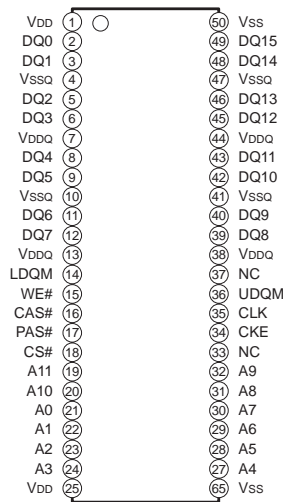

IC131 PCM1723E (D/A Converter)

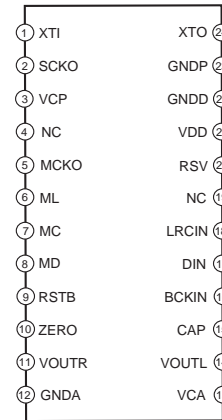

IC112,113 MC74VHC244, TC74VHC244 (AFT Non-Inverted, 3-state Output)

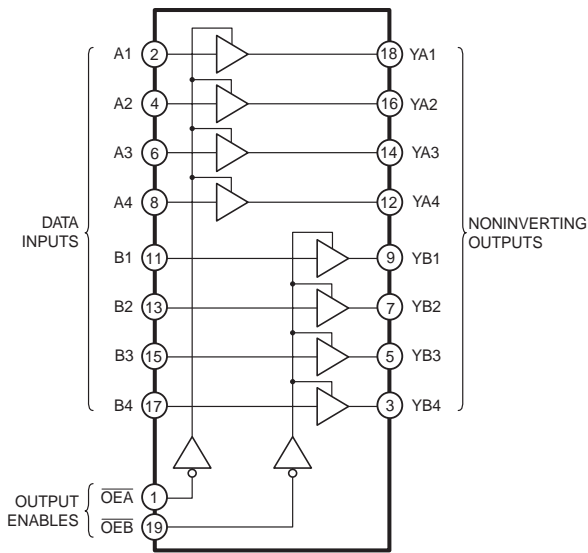

FUNCTION TABLE

INPUTS		OUTPUTS
\overline{OEA} , \overline{OEB}	A, B	YA, YB
L	L	L
L	H	H
H	X	Z

PIN ASSIGNMENT

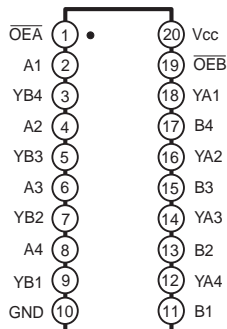

IC132 NJM4560M (OPE AMP)

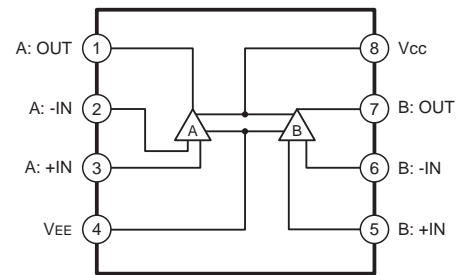

IC133,135,137 TC7SH08FU, NC7SZ08P5 (2 Input and Gate)

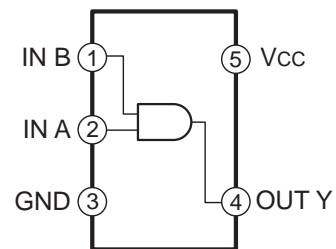

IC136 TC7SHU04FU, NC7SZU04P5 (Inverter)

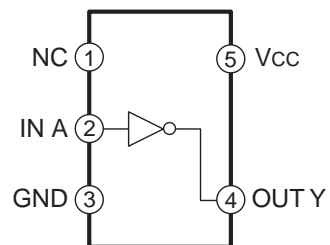

IC BLOCK DAIGRAM & DESCRIPTION

IC110,111,117 EM636165TS,KM416S1120DT, K4S161622D (1 Mega x 16 Synchronous DRAM(SRAM))

Symbol	Type	Description
CLK	Input	Clock: CLK is driven by the system clock. All SDRAM input signals are sampled on the positive edge of CLK. CLK also increments the internal burst counter and controls the output registers.
CKE	Input	Clock Enable: CKE activates(HIGH) and deactivates(LOW) the CLK signal.If CKE goes low synchronously with clock(set-up and hold time same sa other inputs), the internal clock is suspended from the next clock cycle and the state of output and burst address is frozen as long as the CKE remains low. When both banks are in the idle state, deactivating the clock controls the entry to the Power Down and Self Refresh modes. CKE is synchronous except after the device enters Power Down and Self Refresh modes, where CKE becomes asynchronous until exiting the same mode. The input buffers, including CLK, are disabled during Power Down and Self Refresh modes, providing low standby power.
A11	Input	Bank Select: A11(BS) defines to which bank the BankActivate, Read, Write, or BankPrecharge command is being applied.
AC-A10	Input	Address Inputs: A0-A10 are sampled during the BankActivate command (row address A0-A10 and Read/Write command (column address A0-A7 with A10 defining Auto Precharge) to select one location out of the 256K available in the respective bank. During a Precharge command, A10 is sampled to determine if both banks are to be precharged (A10-HIGT). The address inputs also provide the op-code during a Mode Register Set command.
CS#	Input	Chip Select: CS# enables (sampled LOW) and disables (sampled HIGH) the command decoder. All commands are masked when CS# is sampled HIGH. CS# provides for external bank selection on systems with multiple banks. It is considered part of the command code.
RAS#	Input	Row Address Strobe: The RAS# signal defines the operation commands in conjunction with the CAS# and WE# signals and is latched at the positive edges of CLK. When RAS# and CS# are asserted "LOW" and CAS# is asserted "HIGH," either the BankActivate command or the Precharge command is selected by the WE# signal. When the WE# is asserted "HIGH," the BankActivate command is selected and the bank designated by BS is turned on to the active state. When the WE# is asserted "LOW," the Precharge command is selected and the bank designated by BS is switched to the idle state after the precharge operation.
CAS#	Input	Column Address Strobe: The CAS# signal defines the operation commands in conjunction with the RAS# and WE# signals and is latched at the positive edges of CLK. When RAS# is held "HIGH" and CS# is asserted "LOW," the column access is started by asserting CAS#"LOW." Then, the Read or Write command is selected by asserting WE# "LOW" or "HIGH."
WE#	Input	Write Enable: The WE# signal defines the operation commands in conjunction with the RAS# and CAS# signals and is latched at the positive edges of CLK. The WE# input is used to select the BankActivate or Precharge command and Read or Write command.
LDQM, UDQM	Input	Data Input/Output Mask: LDQM and HDQM are byte specific, nonpersistent I/O buffer controls. The I/O buffers are placed in a high-z state when DQM is sampled HIGH. Input data is masked when DQM is sampled HIGH during a write cycle. Output data is masked (two-clock latency) when DQM is sampled HIGH during a read cycle. UDQM masks DQ15-DQ8, and LDQM masks DQ7-DQ0.
DQC-DQ15	Input / Output	Data I/O: The DQ0-15 input and output data are synchronized with the positive edges of CLK. The I/Os are byte-maskable during Reads and Writes.
NC	-	No Connect: These pins should be left unconnected.
VDDQ	Supply	DQ Power: Provide isolated power to DQs for improved noise immunity.(3.3V±0.3V)
VSSQ	Supply	DQ Ground: Provide isolated ground to DQs for improved noise immunity.(0V)
VDD	Supply	Power Supply: +3.3V±0.3V
Vss	Supply	Ground

IC BLOCK DAIGRAM & DESCRIPTION

FL601 Vaccum Fluorescent Display

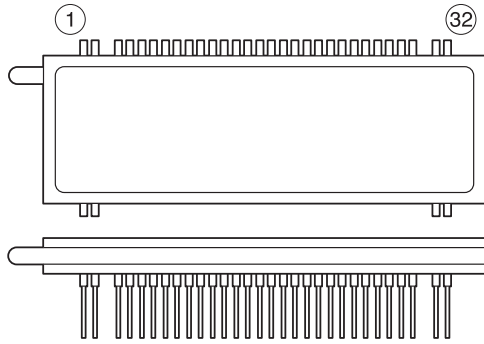

- 1) Fn : Filament pin
- 2) nG : Grid pin
- 3) Pn : Anode pin
- 4) NP : No pin

PIN NO	1	2	3	4	5	6	7	8	9	10	11	12	13	14	15	16
CONNECTION	F1	F1	NP	P1	P2	P3	P4	P5	P6	P7	P8	P9	P10	P11	P12	P13

PIN NO	17	18	19	20	21	22	23	24	25	26	27	28	29	30	31	32
CONNECTION	P14	P15	P16	P17	P18	8G	7G	6G	5G	4G	3G	2G	1G	NP	F2	F2

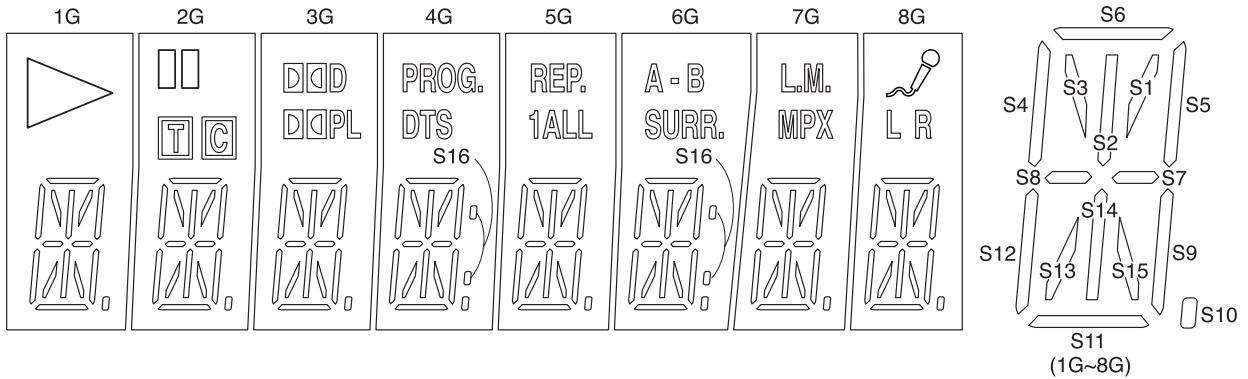
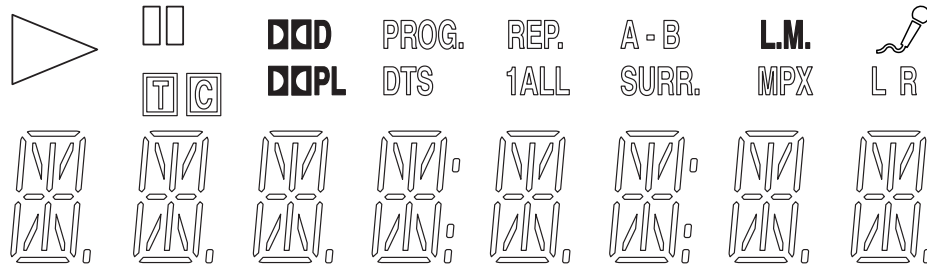

	1G	2G	3G	4G	5G	6G	7 G	8G
P1	S1	S1	S1	S1	S1	S1	S1	S1
P2	S2	S2	S2	S2	S2	S2	S2	S2
P3	S3	S3	S3	S3	S3	S3	S3	S3
P4	S4	S4	S4	S4	S4	S4	S4	S4
P5	S5	S5	S5	S5	S5	S5	S5	S5
P6	S6	S6	S6	S6	S6	S6	S6	S6
P7	S7	S7	S7	S7	S7	S7	S7	S7
P8	S8	S8	S8	S8	S8	S8	S8	S8
P9	S9	S9	S9	S9	S9	S9	S9	S9
P10	S10	S10	S10	S10	S10	S10	S10	S10
P11	S11	S11	S11	S11	S11	S11	S11	S11
P12	S12	S12	S12	S12	S12	S12	S12	S12
P13	S13	S13	S13	S13	S13	S13	S13	S13
P14	S14	S14	S14	S14	S14	S14	S14	S14
P15	S15	S15	S15	S15	S15	S15	S15	S15
P16	△	▯▯	DDD	S16	REP.	S16	L.M.	⤵
P17	▭	▭	DDPL	PROG.	1	A - B	MPX	L
P18	▭	▭		DTS	ALL	SURR.		R

SCHEMATIC DIAGRAM (MPEG)

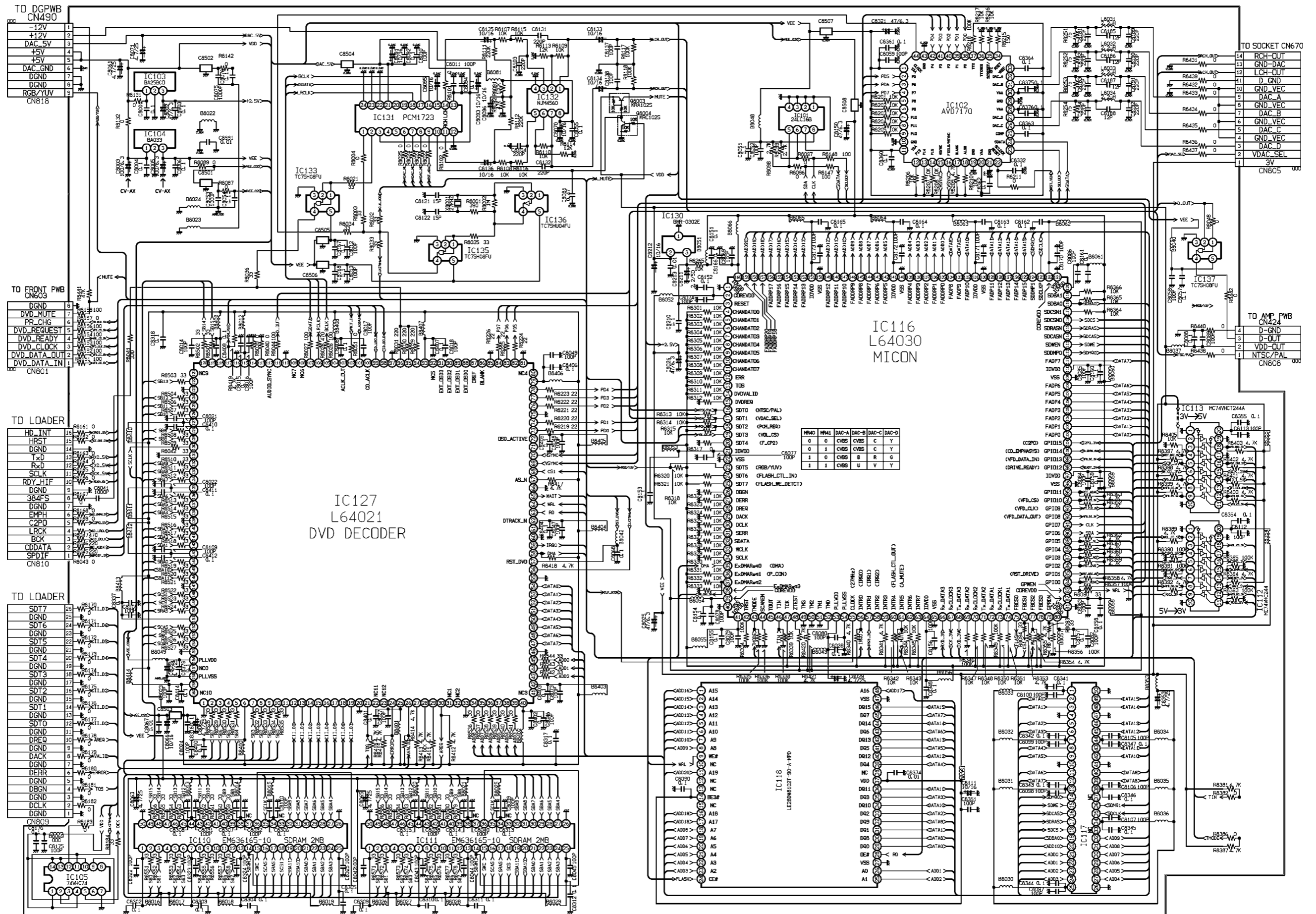

WIRING DIAGRAM (MPEG A SIDE)

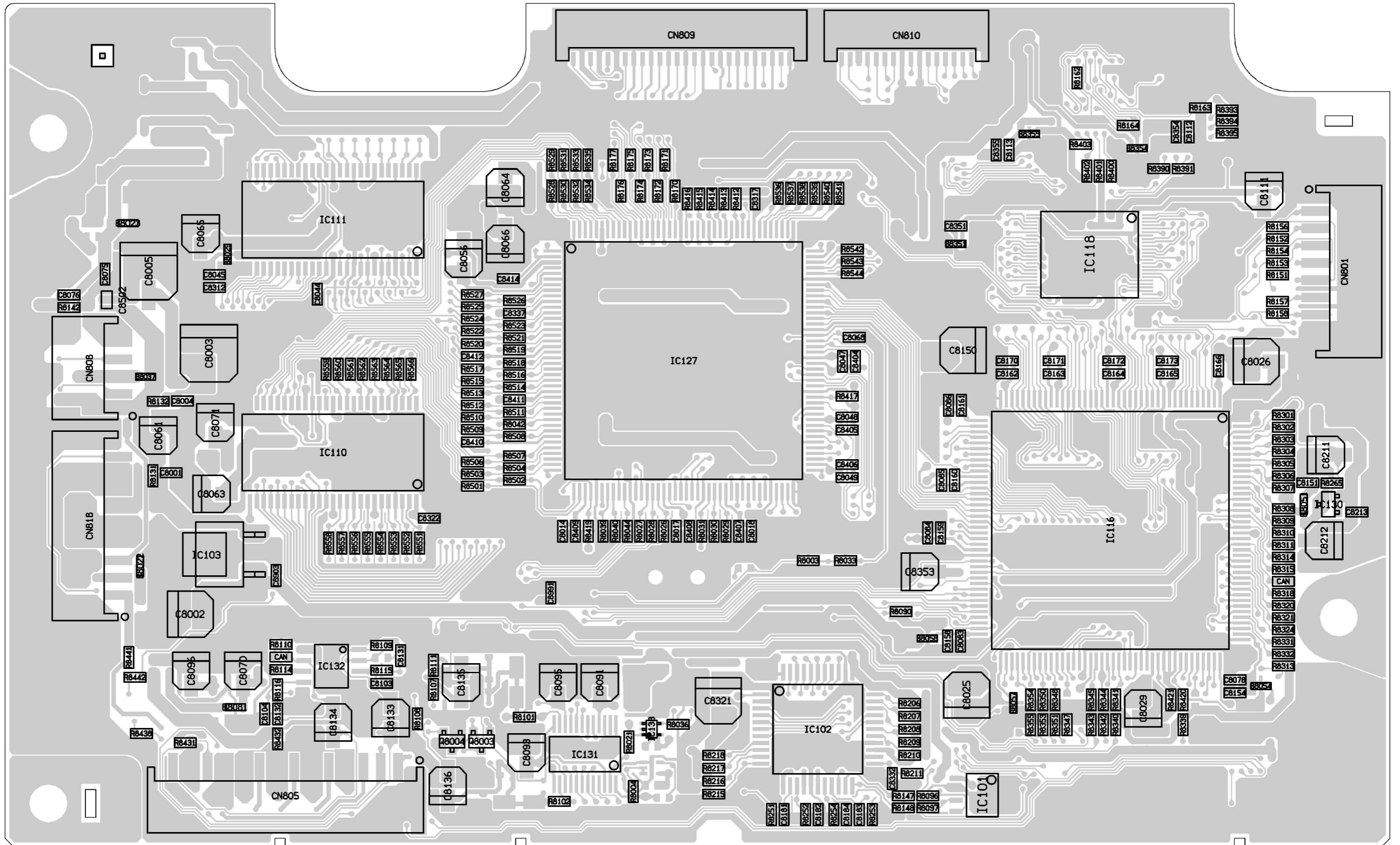

WIRING DIAGRAM (MPEG B SIDE)

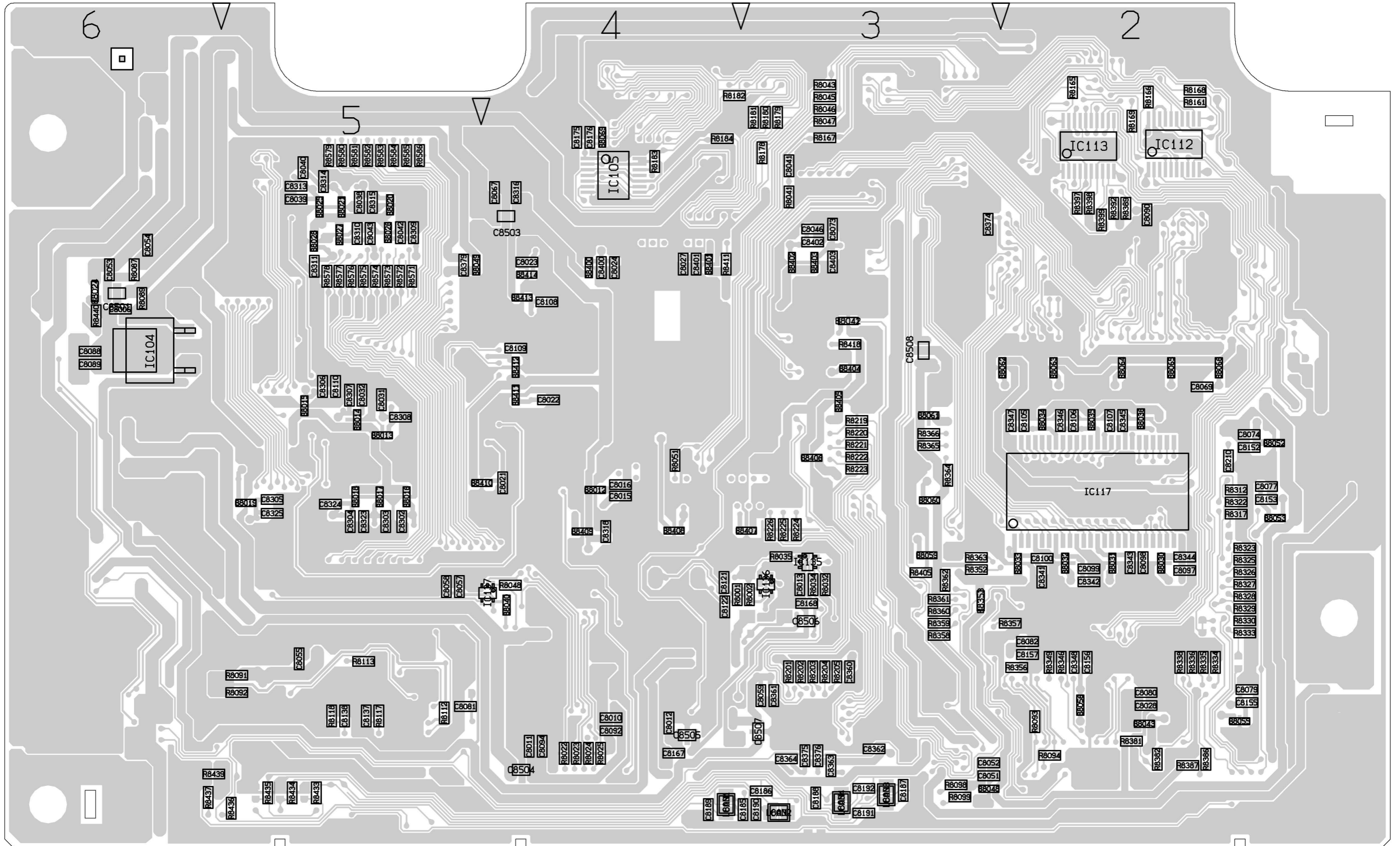

SCHEMATIC DIAGRAM (AMP for 1000,US,CA)

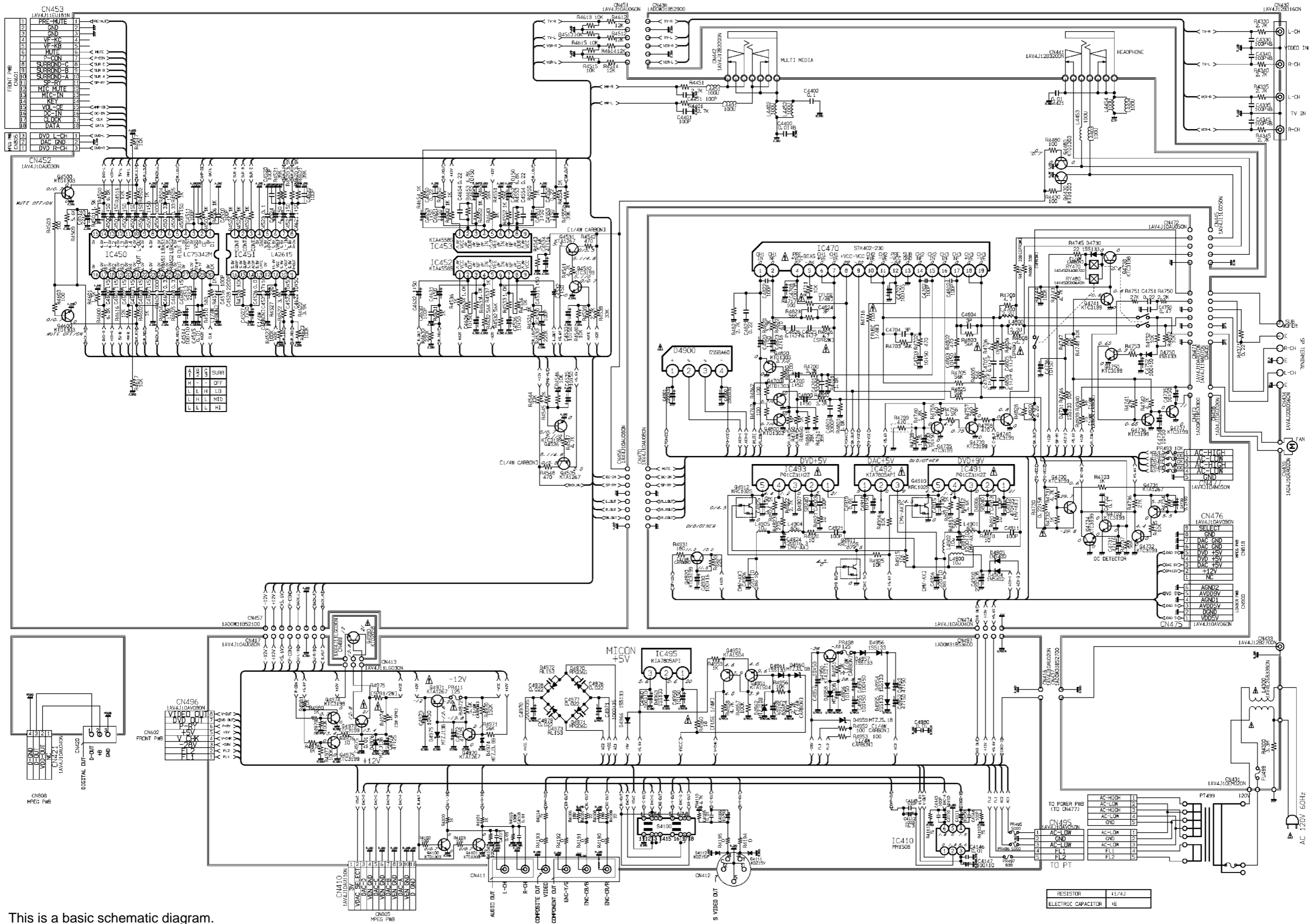

This is a basic schematic diagram.

PRODUCT SAFETY NOTICE

Each precaution in this manual should be followed during servicing. Components identified with the IEC symbol Δ in the parts list and the schematic diagram designated components in which safety can be of special significance. When replacing a component identified by Δ , use only the replacement parts designated, or parts with the same ratings of resistance, wattage or voltage that are designated in the parts list in this manual. Leakage-current or resistance measurements must be made to determine that exposed parts are acceptably insulated from the supply circuit before returning the product to the customer.

SCHEMATIC DIAGRAM (AMP for XE,UK)

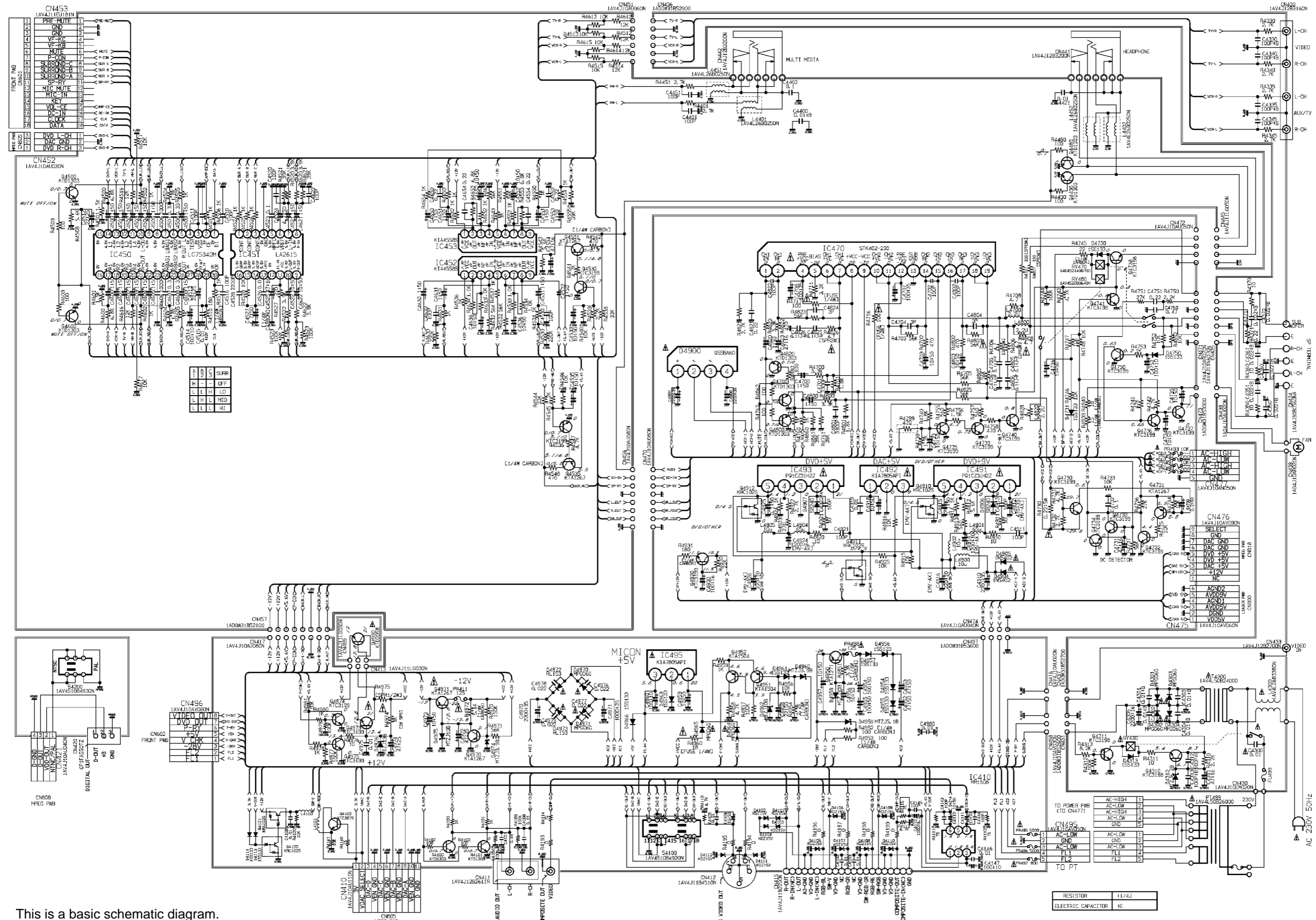

This is a basic schematic diagram.

PRODUCT SAFETY NOTICE

Each precaution in this manual should be followed during servicing. Components identified with the IEC symbol Δ in the parts list and the schematic diagram designated components in which safety can be of special significance. When replacing a component identified by Δ , use only the replacement parts designated, or parts with the same ratings of resistance, wattage or voltage that are designated in the parts list in this manual. Leakage-current or resistance measurements must be made to determine that exposed parts are acceptably insulated from the supply circuit before returning the product to the customer.

RESISTOR	11/4J
ELECTRIC CAPACITOR	#E

WIRING DAIGRAM (PRE-AMP for XE,UK)

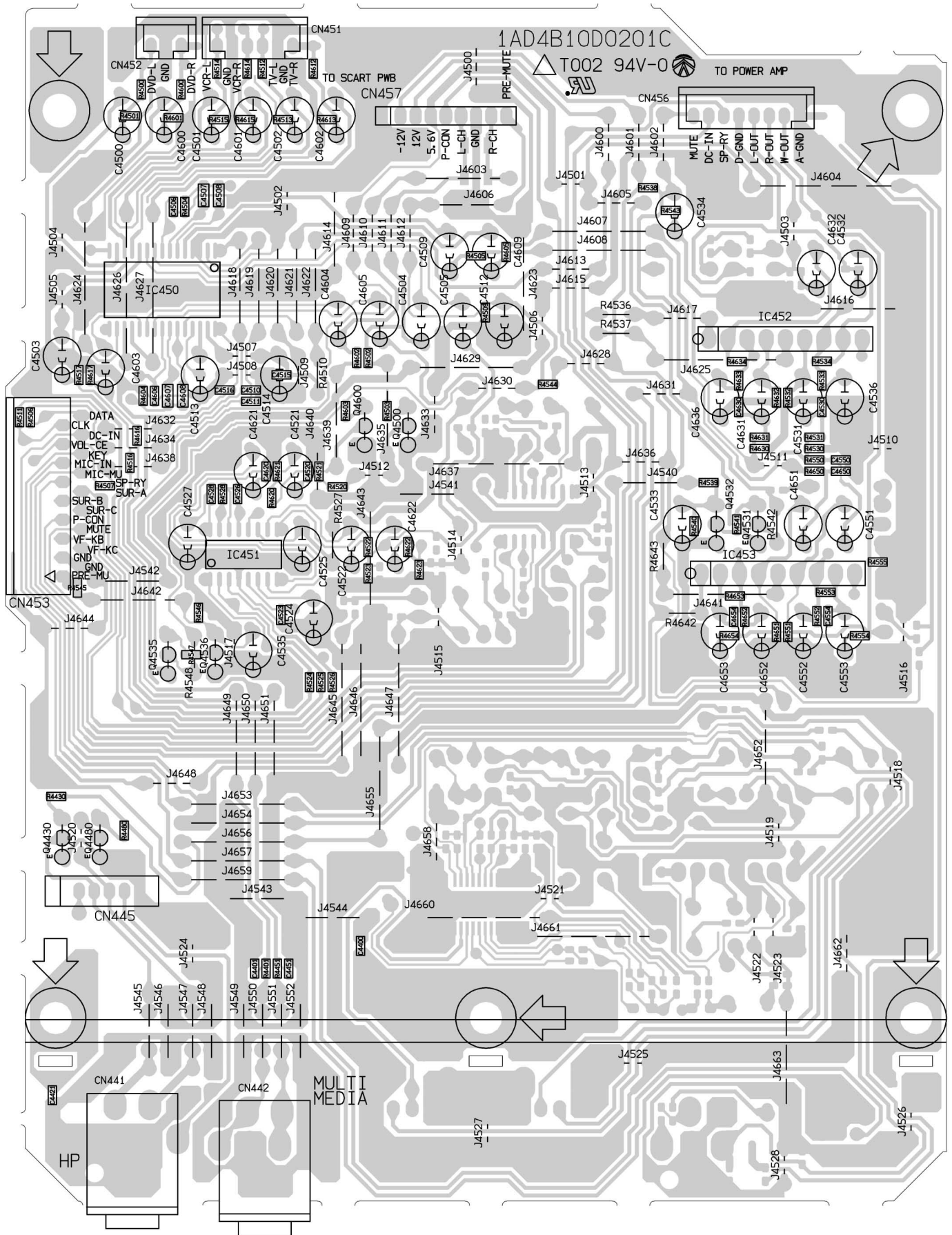

WIRING DIAGRAM (POWER AMP for XE,UK)

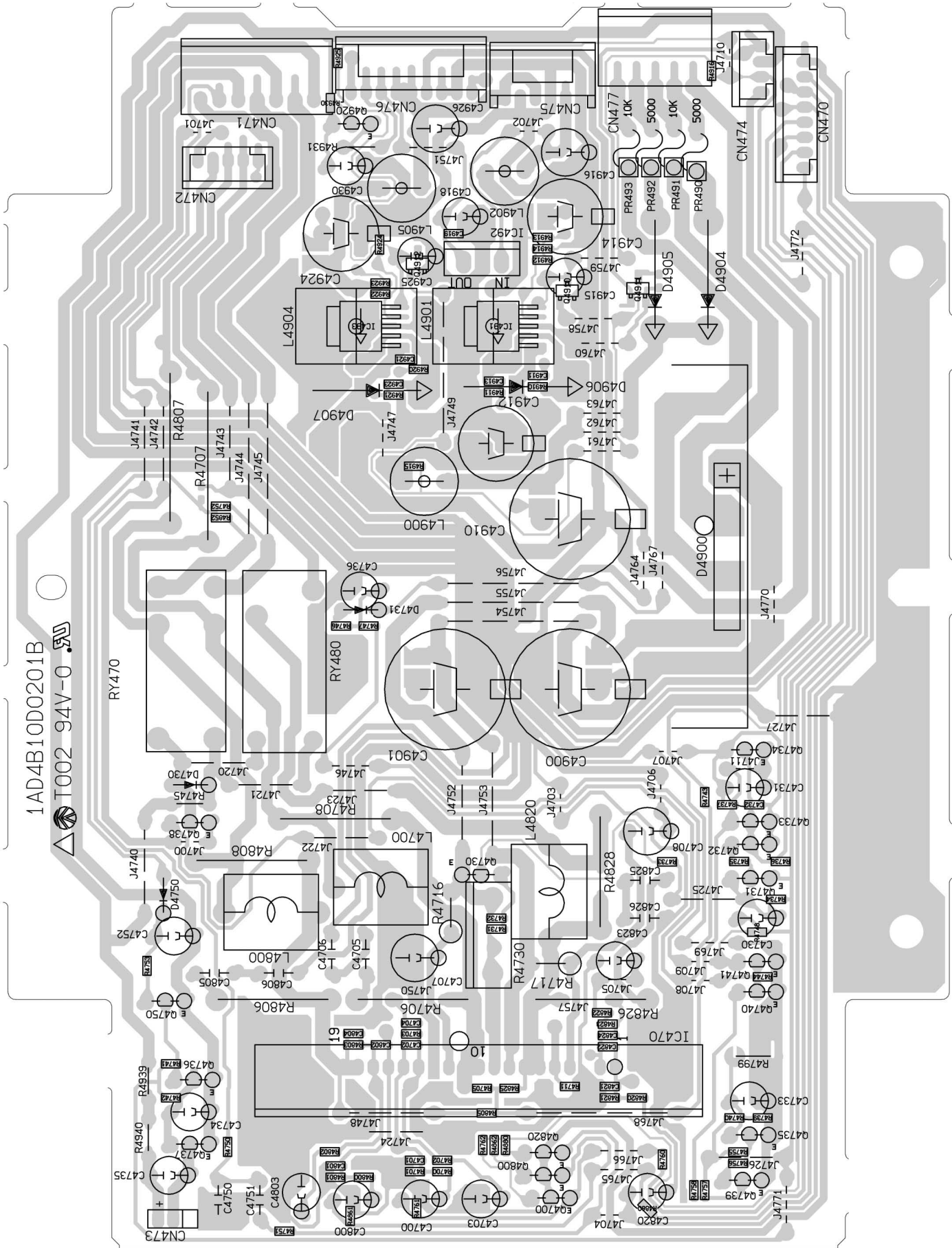

SCHEMATIC DIAGRAM (AMP for SS)

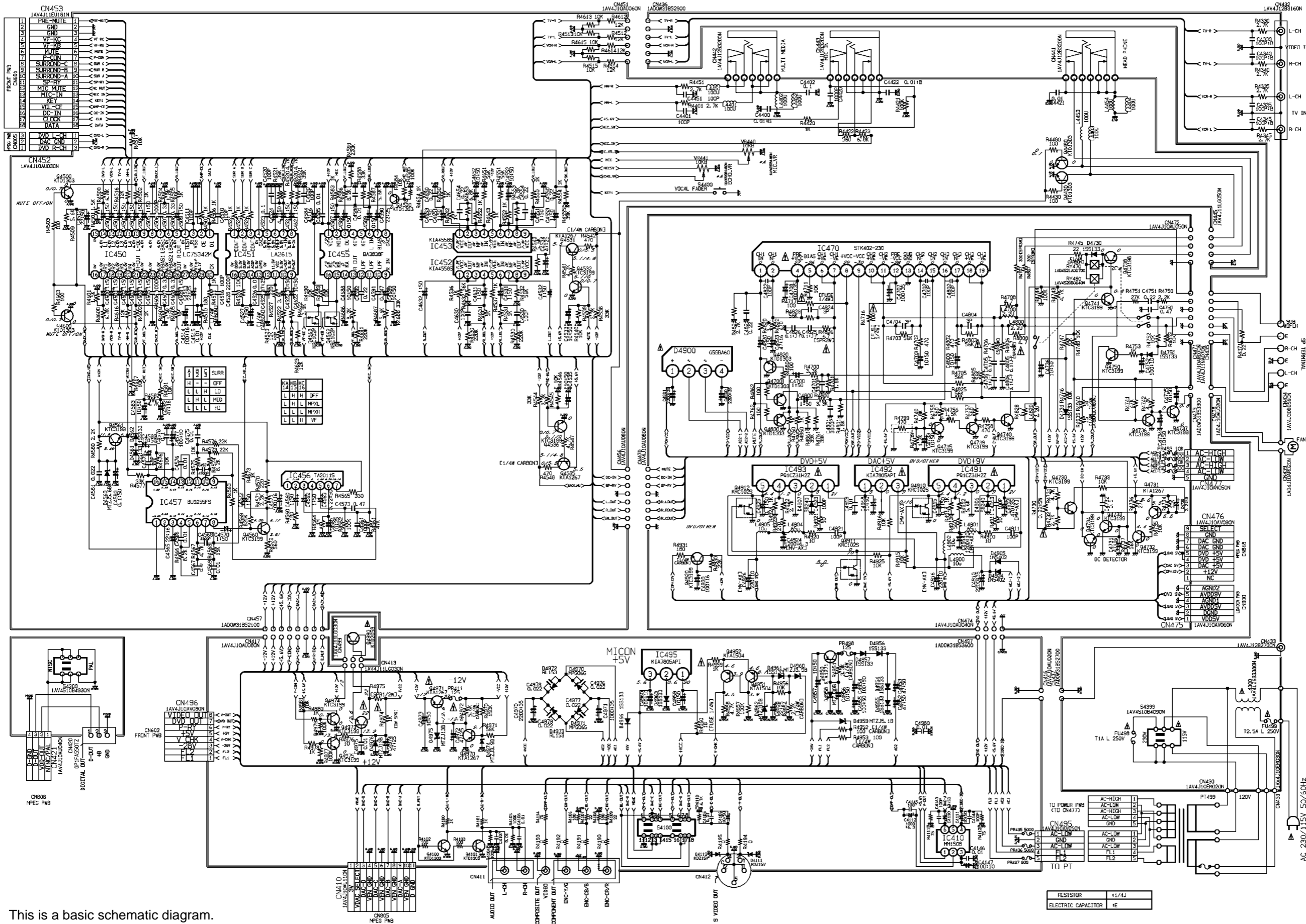

This is a basic schematic diagram.

PRODUCT SAFETY NOTICE

Each precaution in this manual should be followed during servicing. Components identified with the IEC symbol Δ in the parts list and the schematic diagram designated components in which safety can be of special significance. When replacing a component identified by Δ , use only the replacement parts designated, or parts with the same ratings of resistance, wattage or voltage that are designated in the parts list in this manual. Leakage-current or resistance measurements must be made to determine that exposed parts are acceptably insulated from the supply circuit before returning the product to the customer.

WIRING DIAGRAM (POWER AMP for SS,KR)

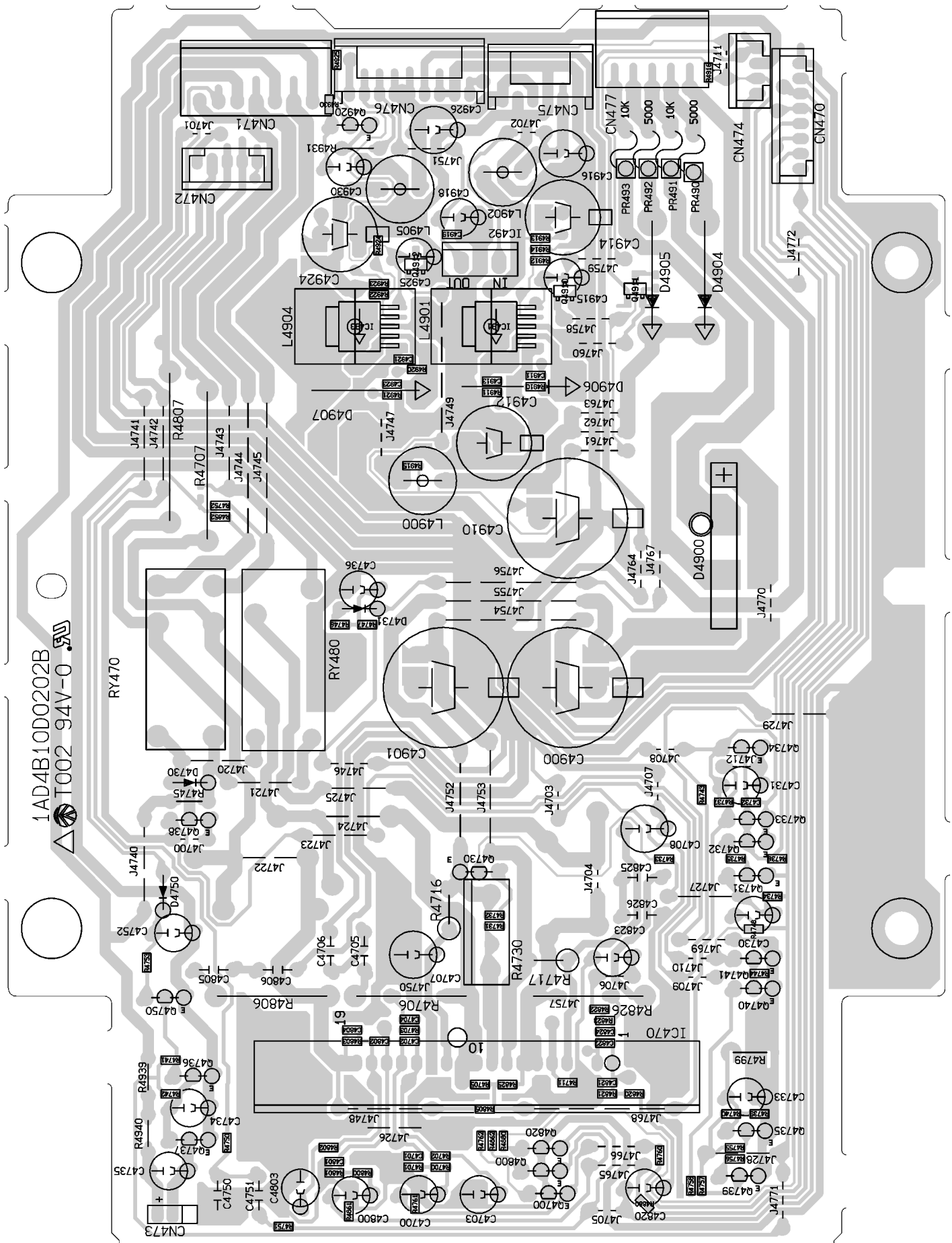

WIRING DIAGRAM (VIDEO-AMP for SS,KR)

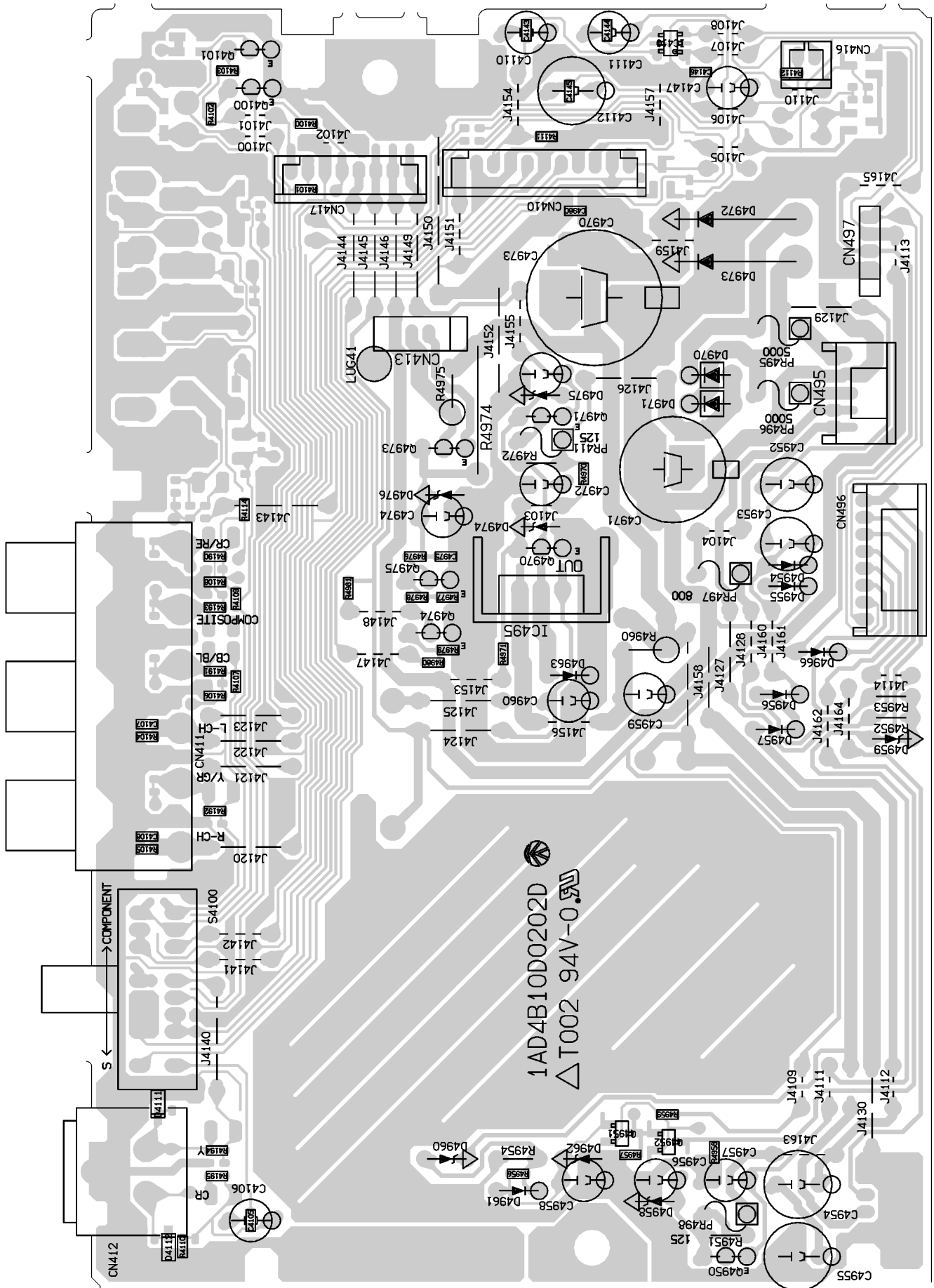

WIRING DIAGRAM (SOCKET-A for SS)

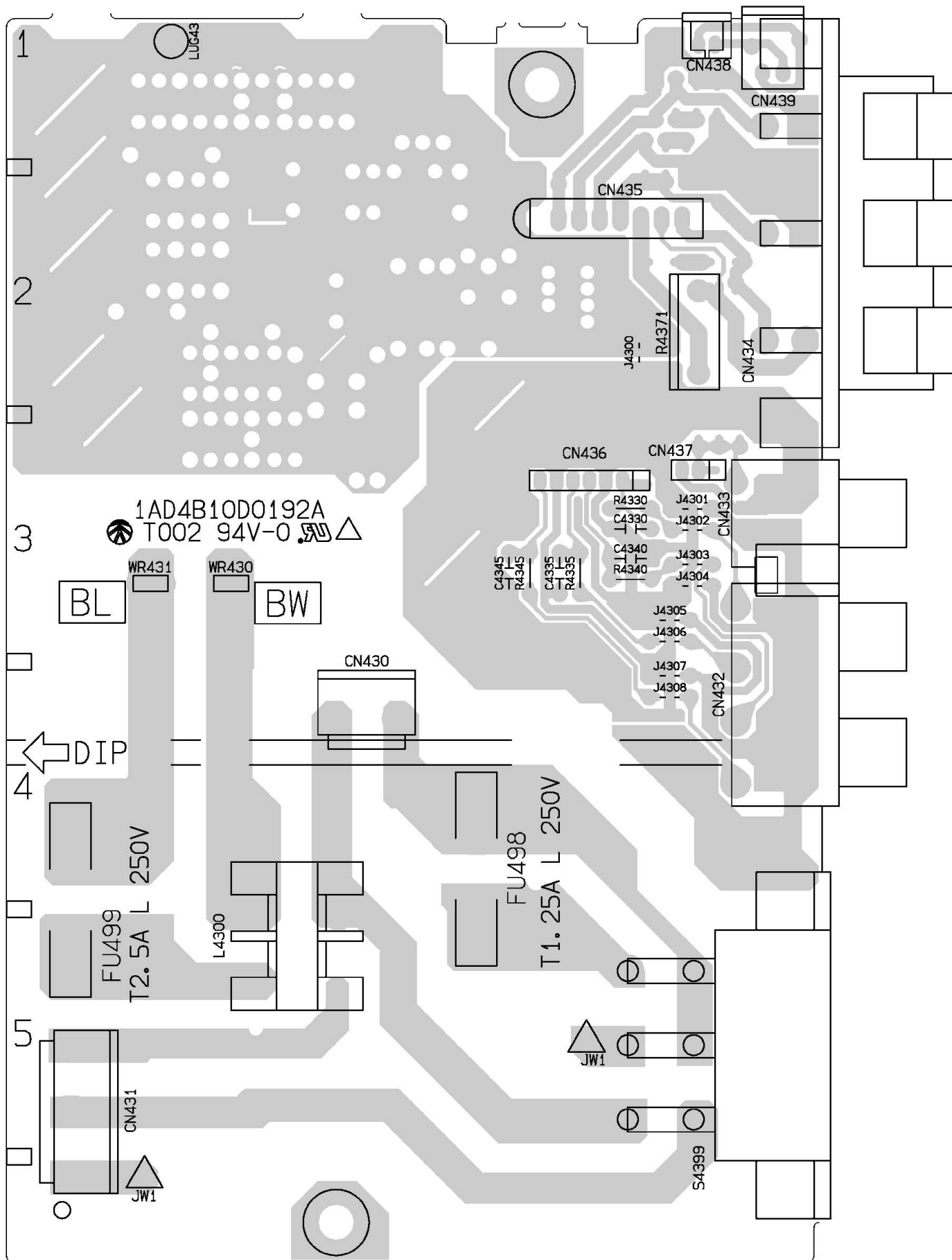

WIRING DIAGRAM (SOCKET-A for KR)

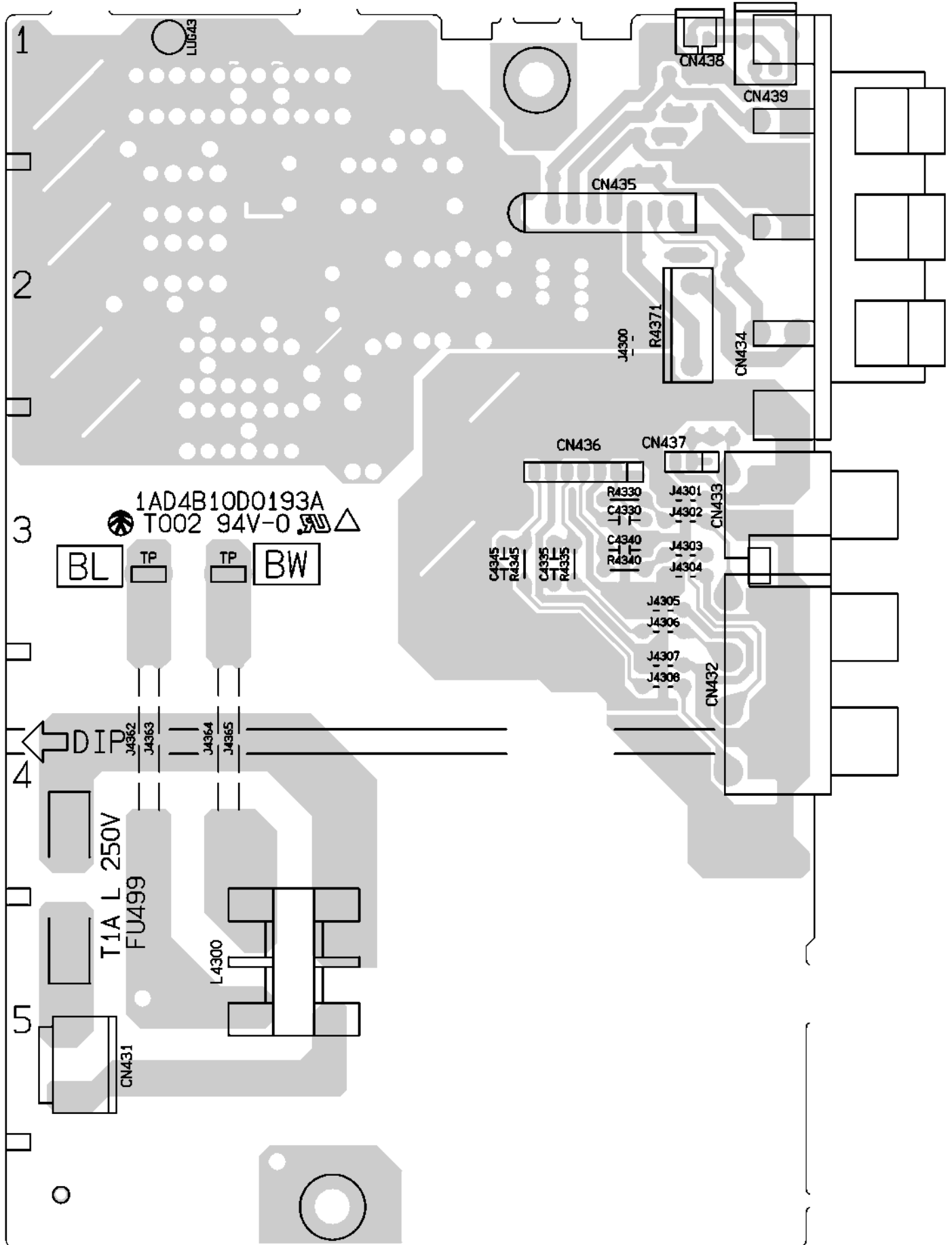

WIRING DIAGRAM (REGULATOR & DIGITAL OUT)

REGULATOR

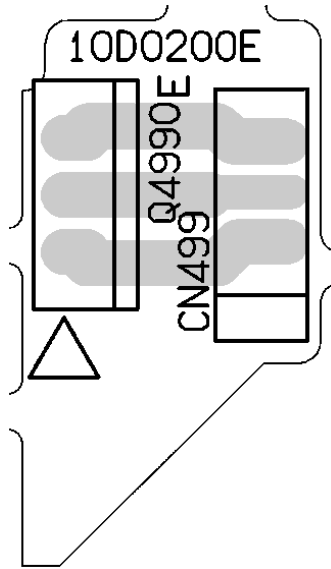

DIGITAL OUT (10000,US,CA)

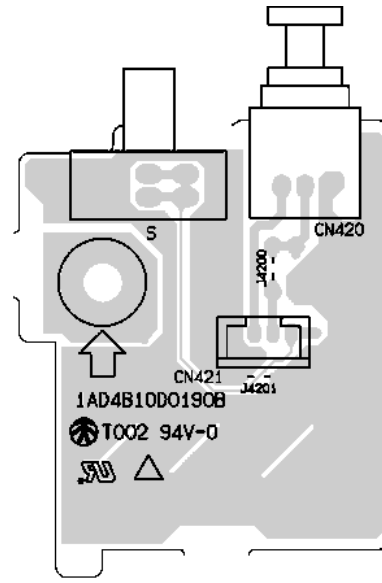

DIGITAL OUT (XE,UK)

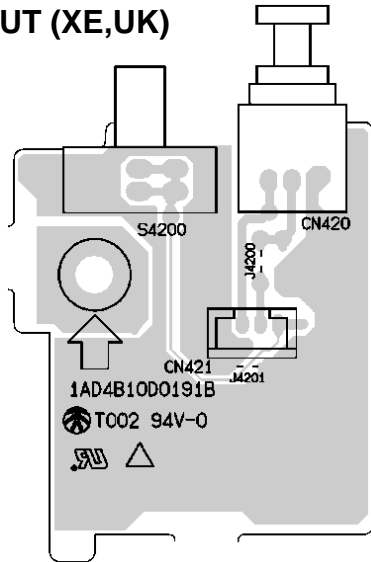

DIGITAL OUT (SS)

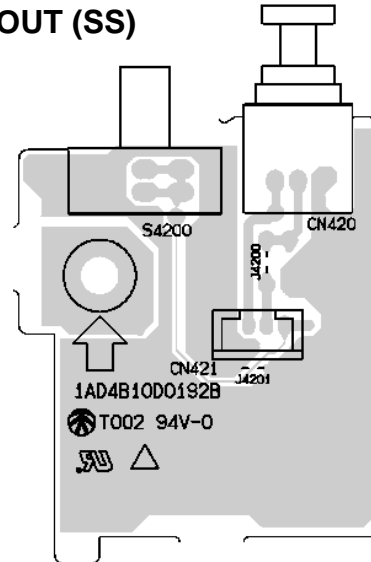

DIGITAL OUT (KR)

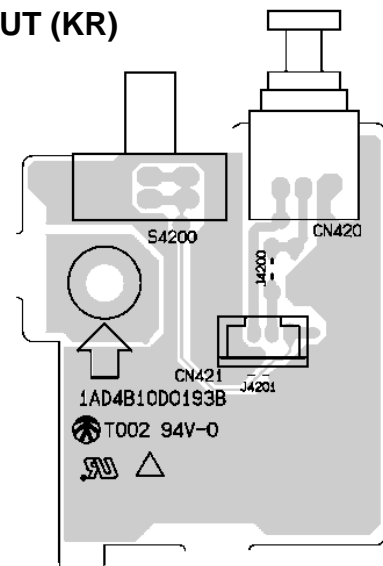

DIGITAL OUT (AU)

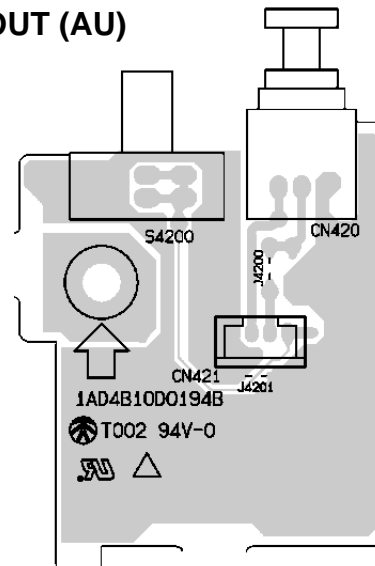

SCHEMATIC DIAGRAM (AMP for AU)

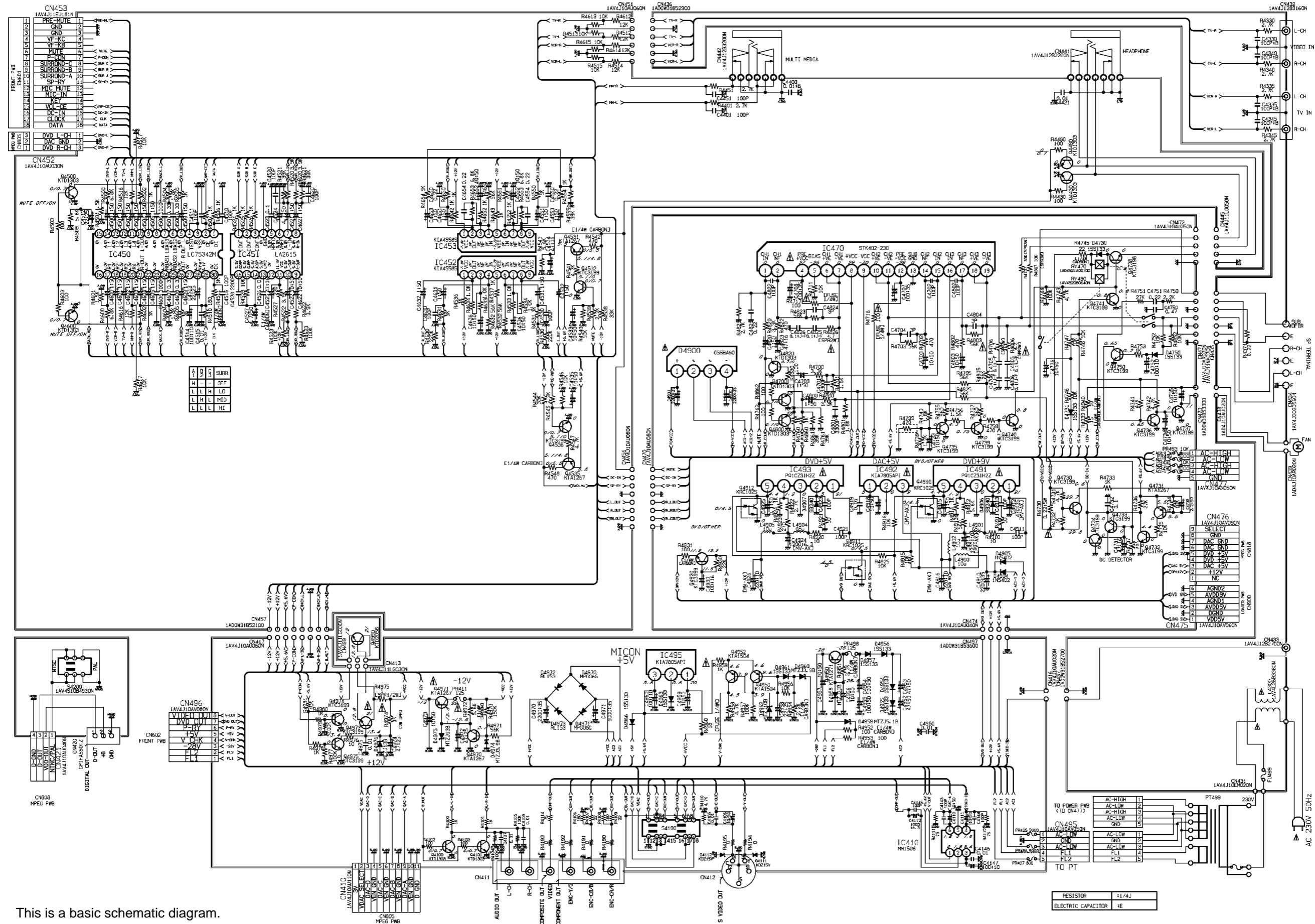

This is a basic schematic diagram.

PRODUCT SAFETY NOTICE

Each precaution in this manual should be followed during servicing. Components identified with the IEC symbol Δ in the parts list and the schematic diagram designated components in which safety can be of special significance. When replacing a component identified by Δ , use only the replacement parts designated, or parts with the same ratings of resistance, wattage or voltage that are designated in the parts list in this manual. Leakage-current or resistance measurements must be made to determine that exposed parts are acceptably insulated from the supply circuit before returning the product to the customer.

SCHEMATIC DIAGRAM (FRONT for 1000,XE,UK,US,CA)

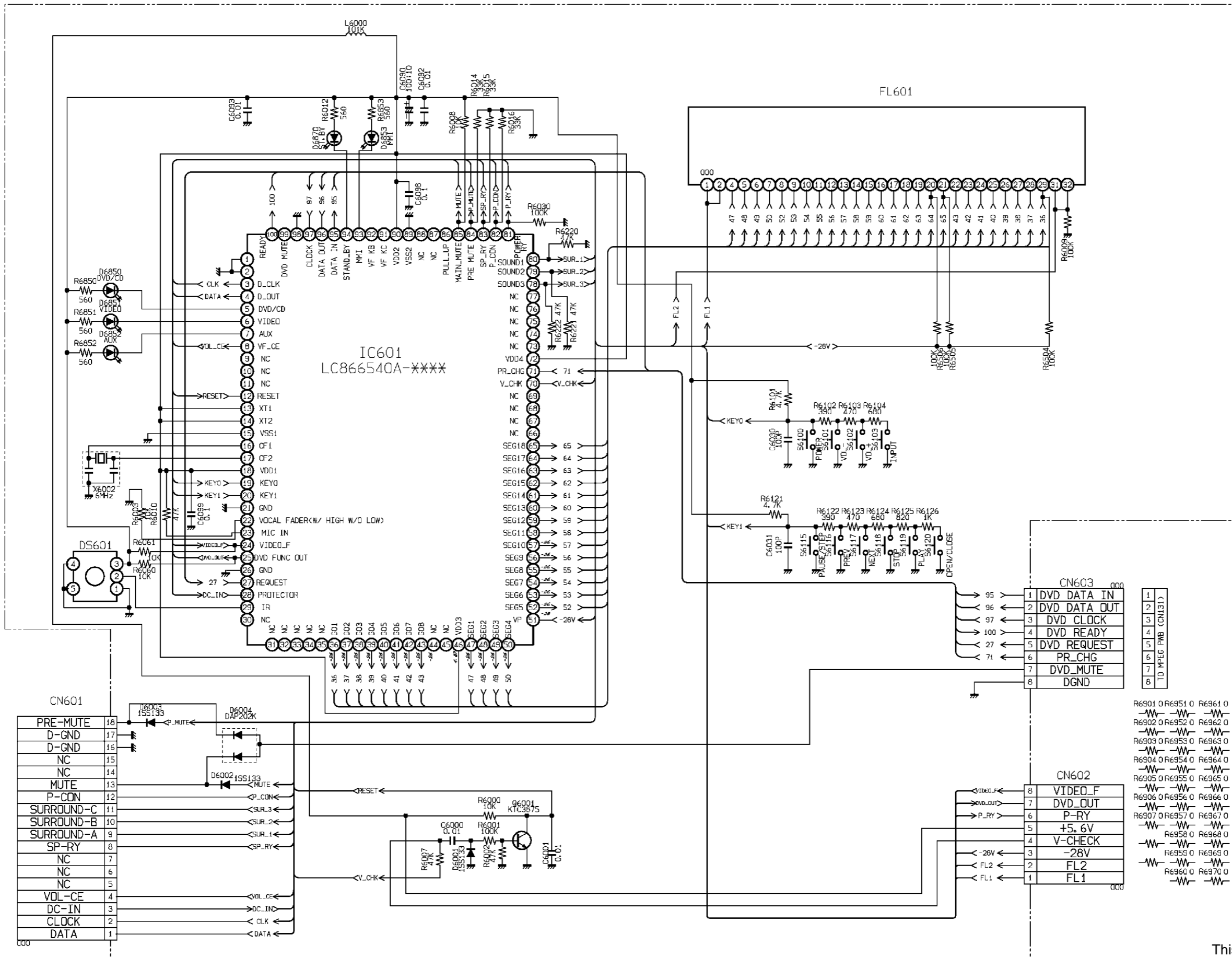

This is a basic schematic diagram.

SCHEMATIC DIAGRAM (FRONT for SS, KR)

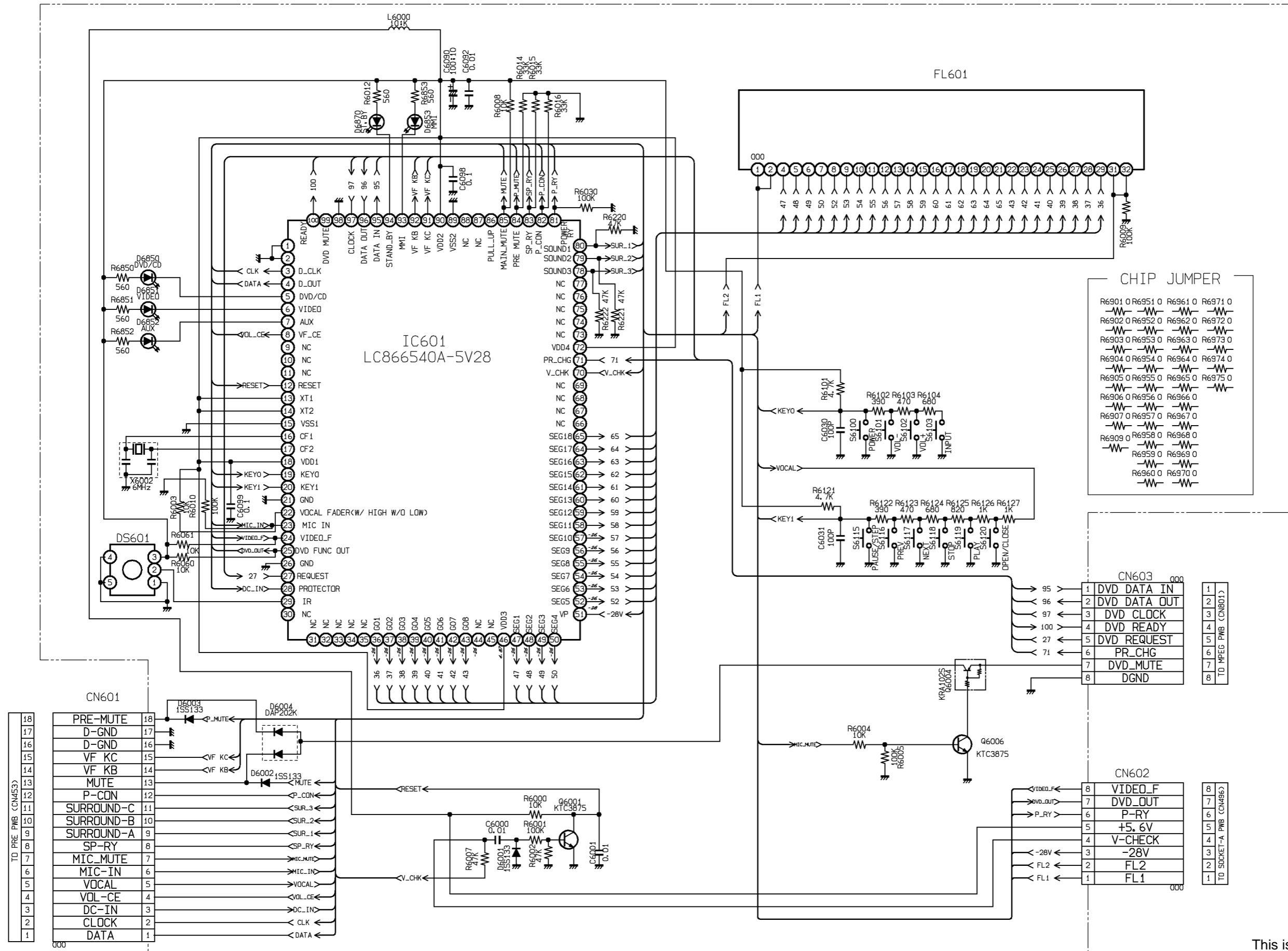

This is a basic schematic diagram.

WIRING DIAGRAM (FRONT for SS,KR)

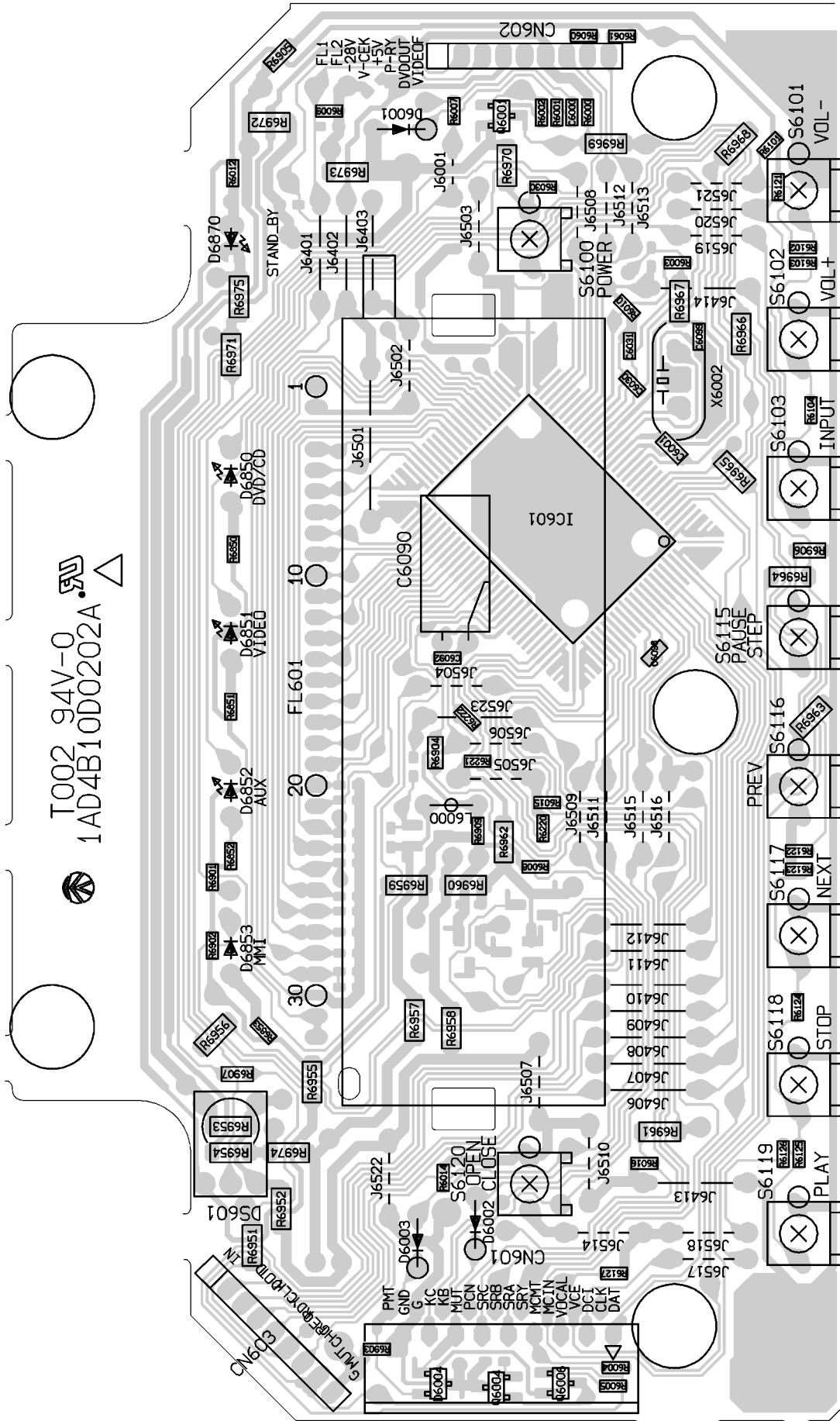

SCHEMATIC DIAGRAM (DVD)

Top left zoon, There is the drawing which zoomed to 120,121 pages.

Top right zoon, There is the drawing which zoomed to 124,125 pages.

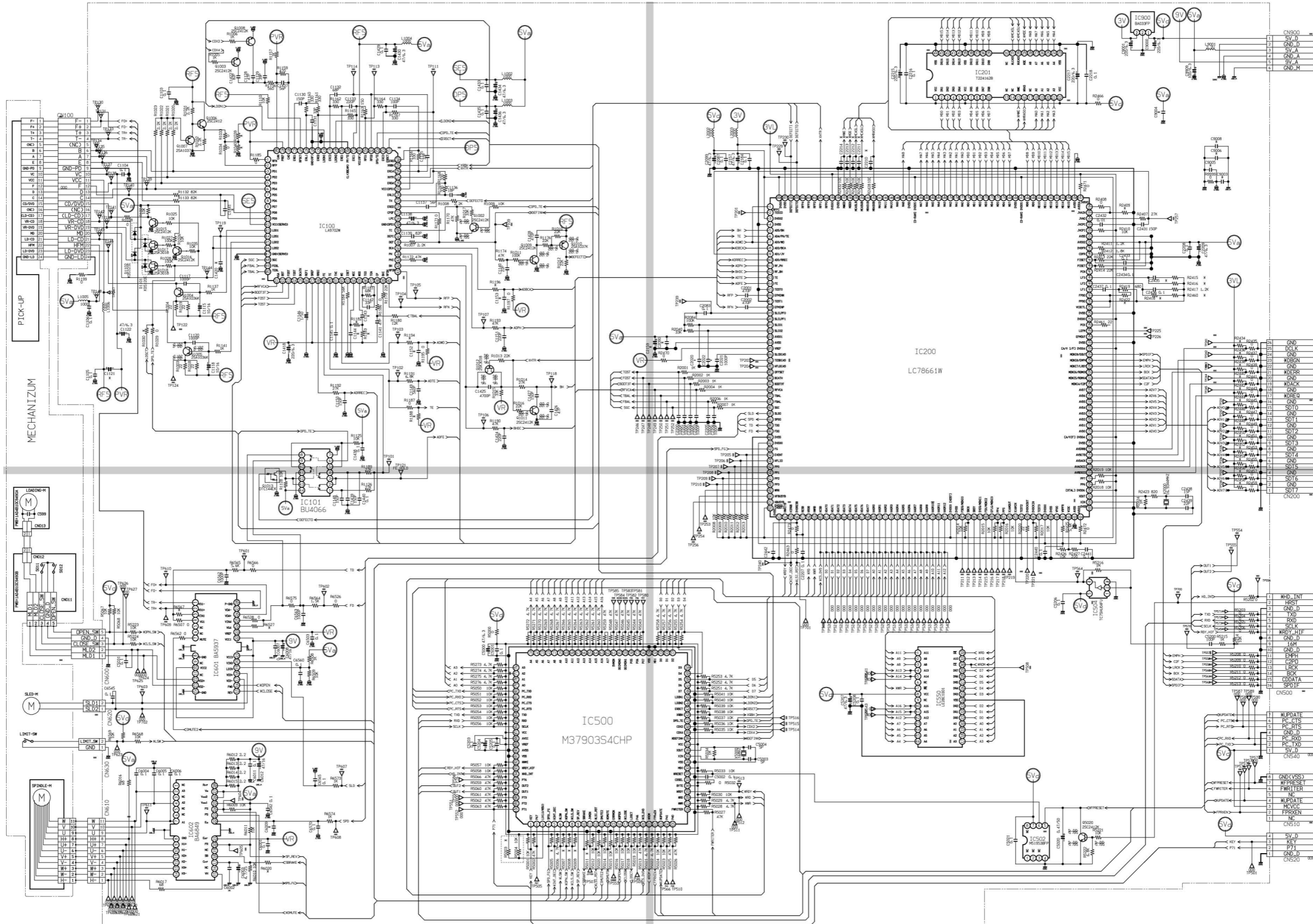

Bottom left zoon, There is the drawing which zoomed to 122,123 pages.

Bottom right zoon, There is the drawing which zoomed to 126,127 pages.

This is a basic schematic diagram.