

SERVICE MANUAL

FISHER

MT-6310

**DC Servo
Stereo Turntable
(EUROPE)**



The first name in high fidelity

Nominal Specifications for Information only.

TURNTABLE	MT-6310
Motor	DC Servo
Drive	Belt
Wow and Flutter (WRMS)	0.04%
Rumble (DIN 45539B)	-68 dB
Speed Variation	±0.8%
Speed Control Range	±3%
Tracking Force Range	0.6-3.5 grams
Platter Diameter	314 mm
Platter Weight	1.0 kg
Strobe Light	Yes
Record Speed Selector	33/45 rpm
Auto Function	
Stop	Yes
Reject	Yes
Manual Function	
Start	Yes
Stop	Yes
Tone Arm Data	
Resonance	<10 Hz
Balance Adjustment	Counter-Weight
Effective Length	222 mm
Shape	S-Form
Bearing-Type	
Horizontal	Thrust
Friction Sensitivity	0.2 gram
Vertical	Pivot
Friction Sensitivity	0.25 gram
Max. Tracking Error	±2.0°
Anti Skate Control	Adjustable
Cueing	Viscous Damped
Overhang Indicator	Yes
GENERAL	
Power Requirements	AC: 110/220V 50/60 Hz
Dimensions (W x D x H)	440x380x138 mm
Weight (approx.)	4.6 kg

Because Fisher products are subject to continuous improvement, Fisher reserves the right to modify, change, or alter any design or specifications without notice and without incurring any obligation. Fisher reserves the right to make changes and improvements upon its products without any obligation to install such changes upon any of its products previously manufactured.

MOUNTING THE CARTRIDGE

1. Carefully mount cartridge according to instructions given by the cartridge manufacturer. Do not tighten mounting screws as yet.
2. Connect the four colored wires found in the cartridge shell to the cartridge terminals. It is important that connections are made correctly. That is, colors of wires and cartridge terminals must be matched.
 Red = Right output
 Green = Right ground
 White = Left output
 Blue = Left ground
3. Plug cartridge shell into tone arm and tighten cartridge shell ring by turning it counterclockwise (as seen from shell side).
4. Move the tone arm over the overhang indicator and adjust cartridge until the stylus point is located exactly above the overhang indicator. Fix cartridge in this location by tightening mounting screws.

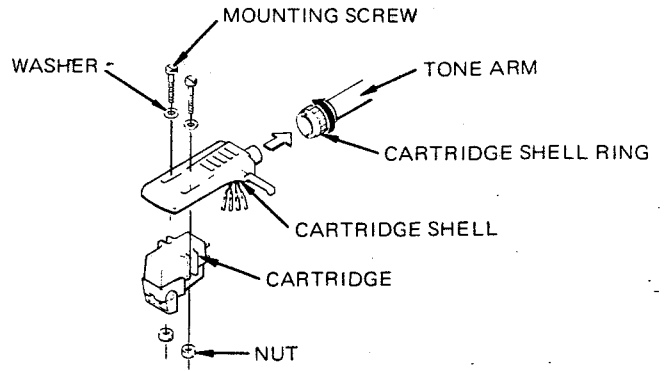

Fig. 1

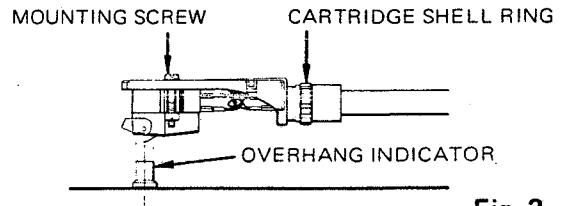

Fig. 2

PICK-UP ARM HEIGHT ADJUSTMENT

When using the cueing lever or the auto-return, perform the pick-up arm height adjustments by turning each adjusting screw as illustrated in Fig. 3. Turn the adjusting screw clockwise to raise the Pick-up Arm, and counter-clockwise to lower it.

PICK-UP RISING POSITION ADJUSTMENT (Return Point)

Change the return point either to inward or outward by turning the return adjusting cum (37).

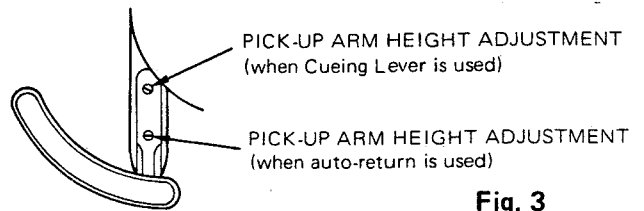
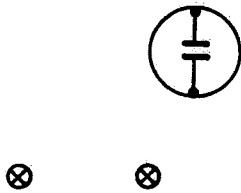
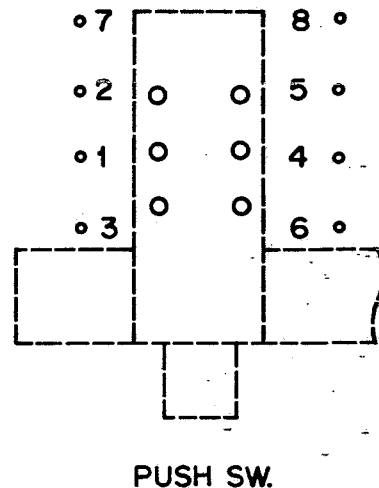

Fig. 3

NEON LAMP P.C.BOARD



SPEED SELECT P.C.BOARD



SPEED CONTROL P.C.BOARD

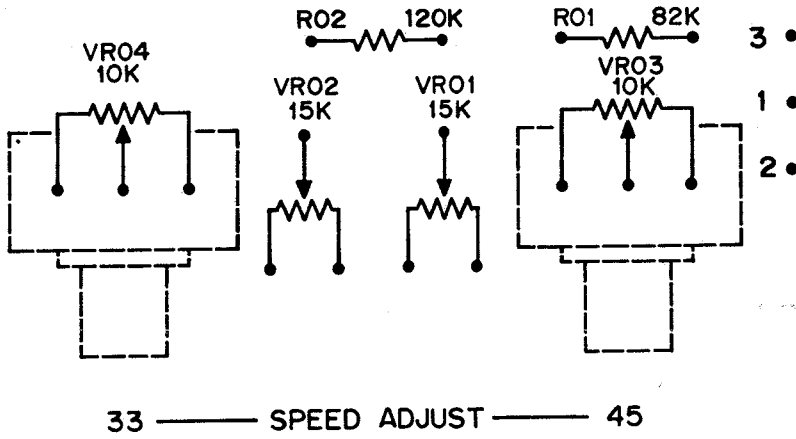

POWER SUPPLY P.C.BOARD

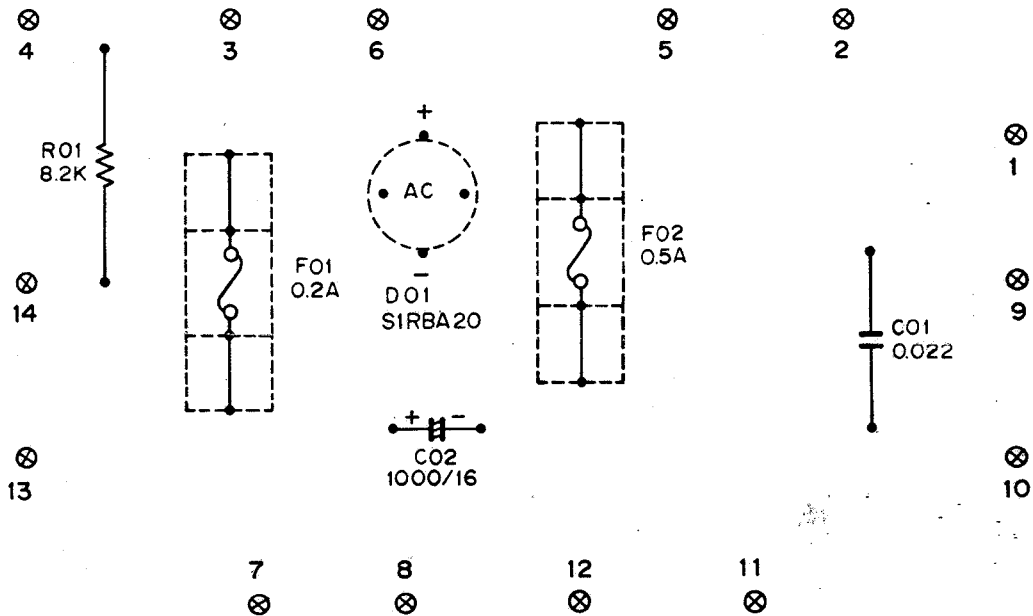

SCHEMATIC DIAGRAM

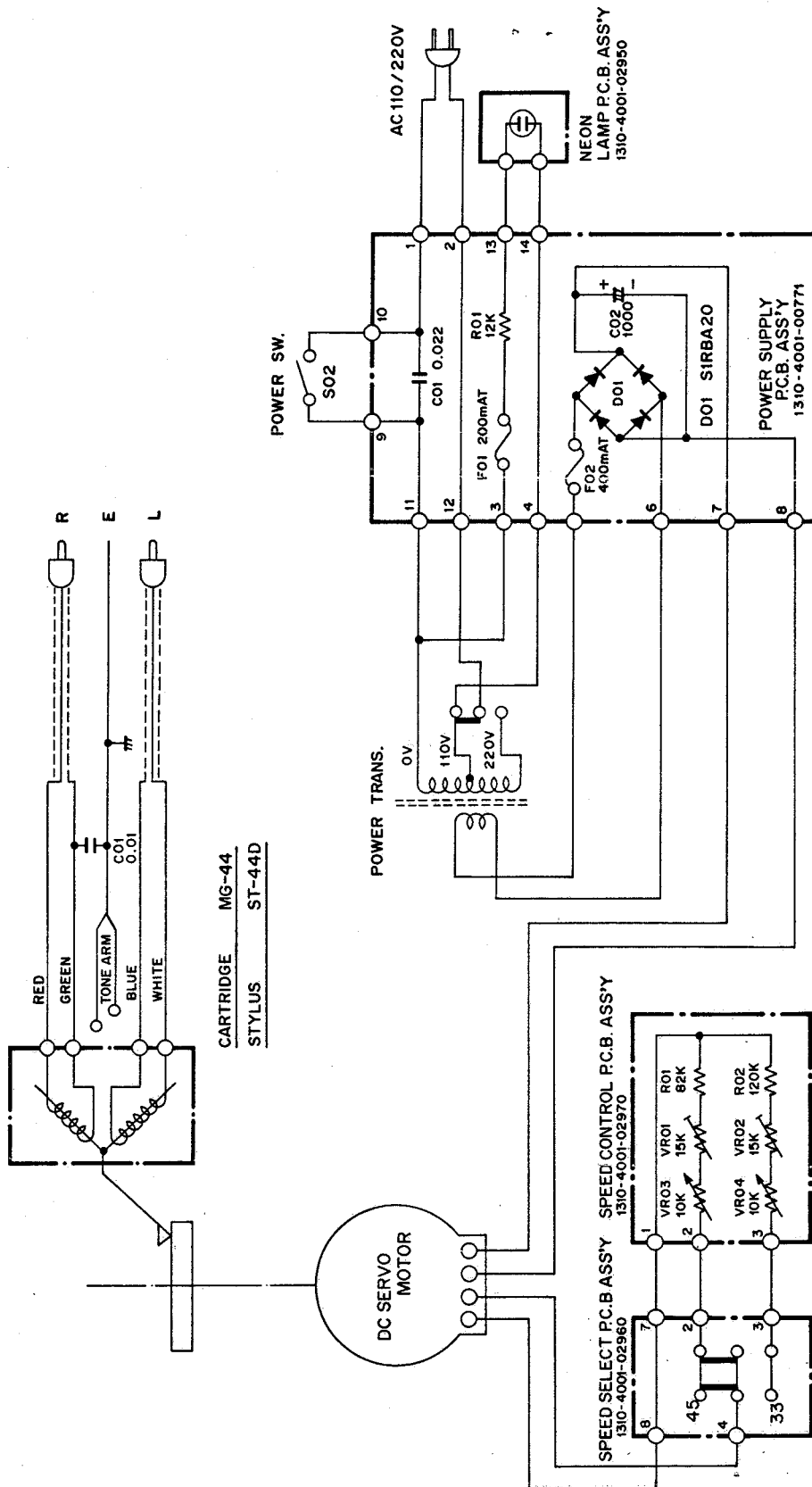

POINT TO POINT WIRING DIAGRAM

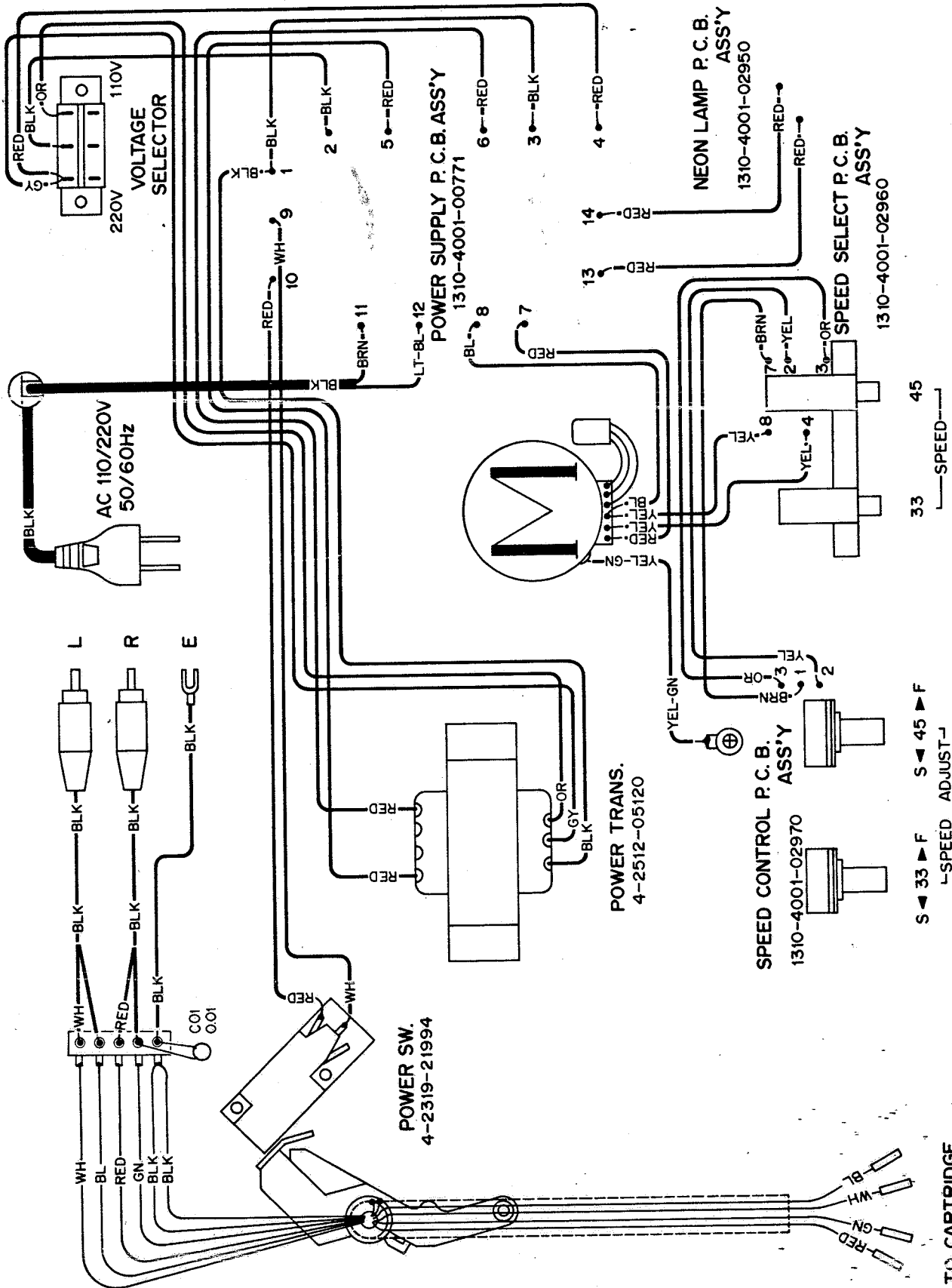

PARTS LIST

PARTS LIST

PACKING PARTS LIST

Ref. No.	Parts Number	Description
	131 6 1139 79400	Box Corrugate-EXP
	131 6 2119 01362	Bag Polyethylene-EXP (Cabinet)
	131 6 2119 01690	Bag Polyethylene-EXP (Lid)
	131 6 2519 01300	Bag Polyethylene-EXP Ind.
	131 6 3009 27520	Pad (Lid Top)
	131 6 3009 29180	Pad (Right)
	131 6 3009 29190	Pad (Left)

ACCESSORIES PARTS LIST

Ref. No.	Parts Number	Description
	131 6 2279 10801	Bag Fan
	131 6 4119 77700	Explanatory Booklet
	131 6 4519 15700	Guarantee Certificate
	134 2 2301 10700	Adapter EP

CABINET PARTS LIST

Ref. No.	Parts Number	Description
1	131 0 2022 90220	Lid Assy
2	131 2 2904 13000	Pad Lid
3	131 0 2002 15000	Hinge Assy (Lid)
4	131 2 1101 41800	Cabinet
5	131 2 1105 24600	Plate Bottom
6	131 0 1003 13500	Leg (Plate Bottom)
7	131 2 1310 30217	Name Plate (Cabinet Rear)
8	131 2 1601 68800	Knob (Speed Select)
9	131 2 1601 68900	Knob (Speed Adjust)
10	131 2 1601 68000	Knob (Reject)
11	131 2 6111 21300	Bushing (SR-4P/1AC Cord)
12	131 2 6308 18101	Filter (Stroke Filter)
13	134 2 5102 13900	Spring Mounting (Leg, Left-Rear)
14	134 2 5102 13901	Spring Mounting (Leg, Right-Front)
15	134 2 5102 13902	Spring Mounting (Leg, Right-Front)
16	131 2 3608 11000	Cramp Wire (Phono Cord)
17*	131 2 4202 12900	Flange Nut

TURNTABLE PARTS LIST

Ref. No.	Parts Number	Description
	131 2 4201 19502	Screw (Screw, Button Head Tapping B-TITE 3) 21-9
22	131 2 3610 10401	Lug Egg Like (Unit Plate)
23	131 2 4220 10600	Ring Snap (Spindle Turntable)
24	134 2 6101 12501	Turntable
25	134 2 6101 11400	Spindle Turntable (Unit Plate)
26	134 2 6302 10800	Belt (Turntable)
27	134 0 6022 12200	Plate PU Fix Assy
28-1	134 0 6030 11301	Gear Cycling Assy
28-2	134 2 4112 11800	Trip
28-3	134 2 4122 12000	Trip
29	134 0 6033 11600	Return Plate Assy
30	134 2 4203 21800	Angle Mount (Reject Angle)
31	134 2 4108 21000	Plate (Switch Plate)
32	134 2 4108 24500	Plate (Reject Angle)
33	134 2 4112 01200	Red (Reject Rod)
34	134 2 4120 18200	Lever (Reject Level)
35	134 2 4120 18300	Lever (Pick-up)
36	134 2 4123 19100	Arm (Return Arm)
37	134 2 4124 12200	Cum (Return Adjust)
38	134 2 5101 20500	Spring (Pick-up)
39	134 2 5101 28000	Spring (Return Plate)
40	134 2 5101 30700	Spring (Reject)
41	134 2 5101 30800	Spring (Switch Plate)
	131 2 4220 10201	Ring Snap
	101 3 1103 00603	Screw, Pan Head 3.0x6
	131 2 4201 21100	Screw
	131 2 4201 21100	Screw
	131 2 4201 19501	Screw (Screw, Button Head Tapping B-TITE 3) 32-2
	131 2 4201 19502	Screw (Screw, Button Head Tapping B-TITE 3) 33-2
	131 2 4201 13511	Screw (TAP/TITE) 3x14
	131 2 4203 17501	Wave Washer
	134 0 6031 11601	Armrest Assy
	134 2 3301 12701	Armrest
	134 2 3308 10800	Holder Pick-up
	134 0 6042 10700	Plate Lifting Assy
	134 2 1601 18200	Knob (Cueing)
	134 2 3301 13500	Armrest
	134 2 4108 24400	Plate (Cueing Plate)
	134 2 4116 11800	Spindle Lifting
	134 2 4120 18400	Lever (Cueing)
	134 2 4121 12000	Guide (Cueing Lever)
	134 2 4201 13200	Screw M3x16 (Support Arm Adj.)
	134 2 5101 24700	Spring (Spindle Lifting)
	134 2 5103 10900	Spring Plate (Cueing Spring)
	104 3 1102 60000	Nut, Hex Head 1.2x6
	108 3 1102 00000	Ring E 2.0
	131 2 4201 20703	Screw (Screw, Button Head Tapping B-TITE 3) 45-1

TURNTABLE PARTS LIST

Ref. No.	Parts Number	Description
	131 2 4201 19501	Screw (Screw, Button Head Tapping B-TITE 3) 52-1
	105 3 1202 60003	Washer, Spring 2.6
	4 1579 21261	Pick-up Assy
	4 1579 26910	Cartridge (M6x44)
	4 1579 29340	Pick-up Stylus (ST-44D)
	134 0 4001 07701	Tone Arm Assy
	134 0 4001 12200	Arm Head Assy
	134 0 4003 01900	PU Weight Assy
	134 0 4004 02701	Arm Assy
	134 2 4201 11314	Screw 2.5x13
	134 2 4202 11301	Nut
	134 2 4203 01800	Washer
	131 0 4004 14402	Wire Shield Assy (Phono P.C.B.)
	131 2 6103 14700	Cover Shield
	134 2 1401 00200	Ring Decorate (PU Base)
	134 2 1404 12800	Housing (Tone Arm Mousing)
	134 2 1601 18100	Knob (IFC Knob)
	134 2 2106 11500	Housing (Tone Arm Housing)
	134 2 2403 21900	Angle Mount (Pick-up Thrust)
	134 2 4117 10600	Support Shaft (PU Shaft Thrust)
	134 2 4124 12100	Cam (IFC Cam)
	134 2 5101 30700	Spring (IFC Spring)
	104 3 1203 00002	Nut, Hex Head 2.3x0
	131 2 4220 10700	Ring Snap 4.9x0.6
	131 2 4201 20800	Screw 2.6x6
	131 2 4201 20802	Screw (Screw, Button Head Tapping B-TITE) 59-2
	131 2 4201 24405	Cap Screw
	102 3 2203 00601	Screw, Button Head Tapping 3.0x6
	102 3 2203 01001	Screw, Button Head Tapping 3x10
	4 2312 01020	Switch Slide (Cabinet Rear)
	4 2319 21994	Switch Micro (Power Switch)
	4 2432 00070	Power Cord
	131 2 7104 00101	Plate Pad Switch (Side Switch)
	134 0 5011 01300	Motor Assy
	134 2 2403 22000	Angle Mount (Front Panel)
	104 3 1203 00002	Nut, Hex Head 2.3x0
	131 2 4201 24203	Screw (SEMS) M2.6x10
	101 3 1103 00603	Screw, Pan Head 3.0x6
	101 3 1103 00808	Screw, Pan Head 3.0x8
	131 2 4201 24307	Screw (SEMS) 3x20
	131 2 4201 19502	Screw (Screw, Button Head Tapping B-TITE 3) 77-1
	131 2 4201 19505	Screw (Screw, Button Head Tapping B-TITE 3) 65-2

Ref. No.	Parts Number	Description
70	131 2 4201 19503	Screw (Screw, Button Head Tapping B-TITE 3) 69-2
71	4 2512 05120	Power Transformer
72	134 2 6103 15201	Mat Turntable
73	134 2 6103 11501	Plate Decorate T.T
74	4 2372 00260	Terminal Lug 1.4PL
	CIHYDZ103A	Ceramic 0.01µF 50V +80-20%
75*	131 0 4001 02950	Neon Lamp P.C.B. Assy
	4 6129 20795	Neon Lamp (100V 5mA)
76*	131 0 4001 02960	Speed Select P.C.B. Assy
	4 2312 01310	Switch Push 2key
77*	131 0 4001 02970	Speed Control P.C.B. Assy
	4 2222 00710	VR 15K-B
	VR01.02	4 2222 00710 VR 10K-Bx1
	VR03.04	4 2222 00710 VR 10K-Bx1
R01	R2EDP1B23A	Carbon 82K 1/4W ±5%
R02	R2EDP1J24A	Carbon 120K 1/4W ±5%
78*	131 0 4001 00771	Power Supply P.C.B. Assy
	4 2369 23060	Socket
	4 2372 00060	Receptacle
	4 2349 20960	Fuse 0.2A
	4 2349 20131	Fuse 0.4A
CAPACITORS		
	C2EHRM223A	Metallized Paper 0.022µF 250V ±20%
	C10RE-108A	Electrolytic 1000µF 16V
SEMICONDUCTORS		
	DDD-STRBA20	Diode Bridge 1A
RESISTORS		
	R3AXBJ123A	Oxide Metal Film 12k ohm 1W ±5%

Note: * Asterisk indicates not a service part.
The numbers for screws, nuts, and washers, shown in Description, correspond with Ref. Nos. of the parts using these screws, nuts and washers.

Example: 3 means Ref. No. 2 means Qty.

EXPLODED VIEW OF CABINET & TURNTABLE

