

SERVICE MANUAL



FISHER

MT-6330

MT-6330C

**Linear Motor
Direct Drive Turntable**



The first name in high fidelity

U.S.

SPECIFICATIONS

TURNTABLE	MT-6330
Motor	120 Pole Linear AC Servo
Drive	Direct
Wow and Flutter (WRMS)	0.035 %
Rumble (DIN 45539B)	-70 dB
Speed Variation	±0.5%
Speed Control Range	±3 %
Tracking Force Range	0.6 – 3.5 grams
Tracking Force Adjustment	Calibrated Counter Weight
Platter Diameter	12-3/8"
Platter Weight	2.2 lbs.
Strobo Light	Yes
Record Speed Selector	33/45 rpm
Auto Function	
Stop	Yes
Reject	Yes
Automatic	
Tone Arm Return at End of Record	Yes
Manual Function	
Start	Yes
Stop	Yes
Tone Arm Data	
Resonance	<10 Hz
Balance Adjustment	Counter-Weight
Effective Length	222 mm
Shape	S-Form
Bearing-Type	
Horizontal	Thrust
Friction Sensitivity	0.18 gram
Vertical	Pivot
Friction Sensitivity	0.22 gram
Max. Tracking Error	±1.8°
Anti Skate Control	Calibrated Adjustable
Cueing	Viscous Damped
Overhang Indicator	Yes
GENERAL	
Power Requirements	120V AC ±10% 50/60 Hz 3.5 W
Dimensions (W x D x H)	17-5/16" x 14-15/16" x 5-7/16"
Weight (approx.)	13.7 lbs.

Because Fisher products are subject to continuous improvement, Fisher reserves the right to modify, change, or alter any design or specifications without notice and without incurring any obligation. Fisher reserves the right to make changes and improvements upon its products without any obligation to install such changes upon any of its products previously manufactured.

NEON LAMP P.C.BOARD

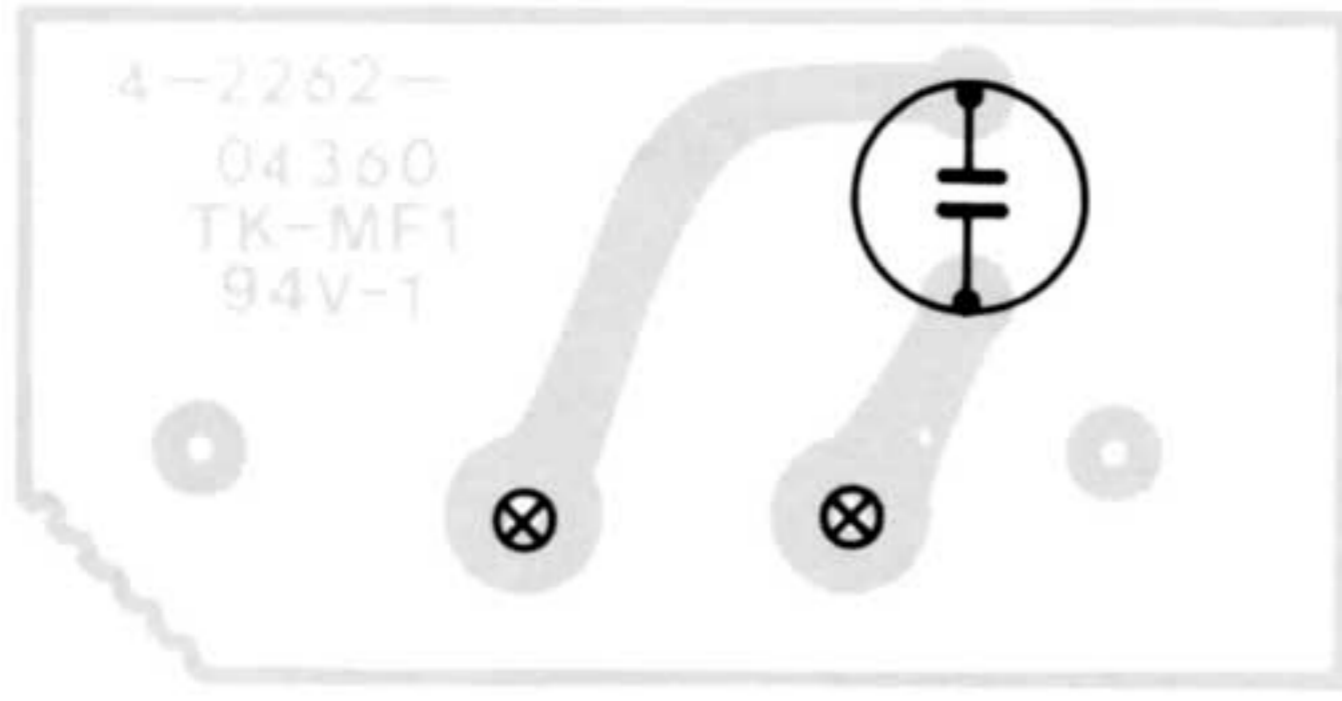

PHONO P.C.BOARD

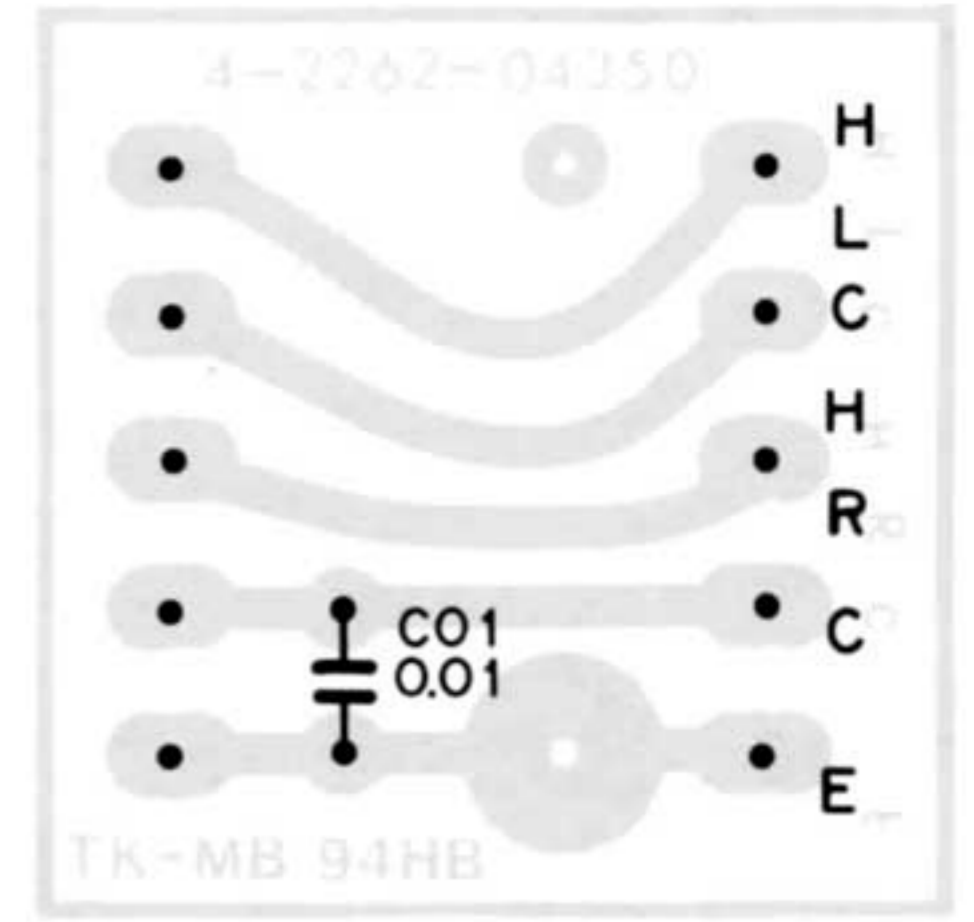

SPEED SELECT P.C.BOARD

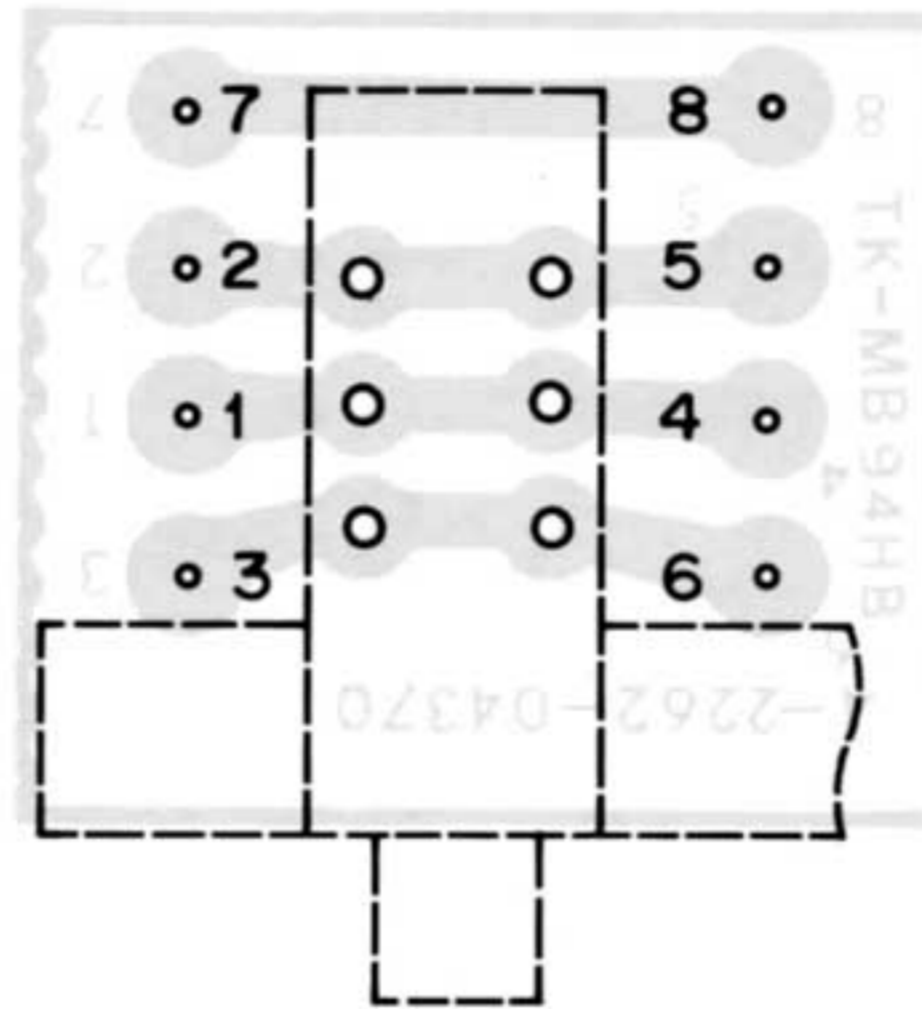

PUSH SW.

SPEED CONTROL P.C.BOARD

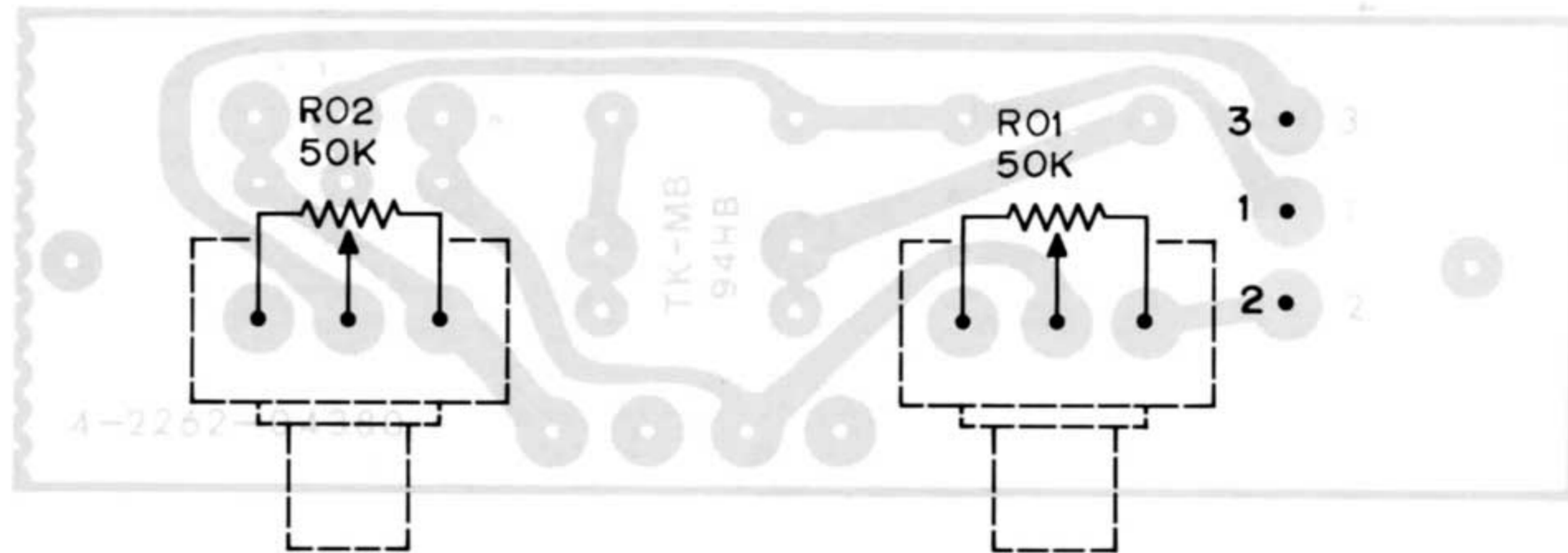

33 ——— SPEED ADJUST ——— 45

PARTS LIST

PHONO P.C.B. Assy
131 0 4001 02940

Ref. No.	Parts Number	Description
CAPACITORS		
C01	C1HYDZ103A	Ceramic 0.01 μ F 50V +80,-20%

NEON LAMP P.C.B. ASSY
131 0 4001 02950

Ref. No.	Parts Number	Description
	4 6129 20795	Neon Lamp

SPEED SELECT P.C.B. Assy
131 0 4001 02961

Ref. No.	Parts Number	Description
	4 2312 01310	Switch Push 2key

SPEED CONTROL P.C.B. Assy
131 0 4001 02972

Ref. No.	Parts Number	Description
VR01,02	4 2222 01170	VR 50k-Bx1

PARTS LIST

MOTOR CONTROL P.C.B. Assy 131 0 4001 00470

Ref. No.	Parts Number	Description
	4 2589 20900	OSC Coil
VR01	4 2229 26150	VR 200k-B
VR02,03	4 2229 26070	VR 200

CAPACITORS

C01	C1HFYK102APA	Mylar	0.001 μ F	50V	\pm 10%
C02	C1ARY-336APA	Electrolytic	33 μ F	10V	
C03	C1HFAK154A	Mylar	0.15 μ F	50V	\pm 10%
C04	C1HFAM473A	Mylar	0.047 μ F	50V	\pm 20%
C05	C1CRY-106APA	Electrolytic	10 μ F	16V	
C06	C1HRY-105APA	Electrolytic	1 μ F	50V	
C07	C1ERY-475APA	Electrolytic	4.7 μ F	25V	
C08,09	C1HFYK333APA	Mylar	0.033 μ F	50V	\pm 10%
C10	C1HFYK222APA	Mylar	0.0022 μ F	50V	\pm 10%
C11	C1HFYK223APA	Mylar	0.022 μ F	50V	\pm 10%
C12,13 14	C1HFAM473A	Mylar	0.047 μ F	50V	\pm 20%
C15,16 17	C1HFYK333APA	Mylar	0.033 μ F	50V	\pm 10%
C18	C1CRE-227A	Electrolytic	220 μ F	16V	
C19	C1CRE-107A	Electrolytic	100 μ F	16V	
C20	C1CRY-106APA	Electrolytic	10 μ F	16V	

SEMICONDUCTORS

D01,02 03	202 5 9110 18824	Diode, 1S188FM1
IC01	IUU-LM324	IC, LM324 (4Ch OP Amp.)
IC02	IVV-CX-065A	IC, CX-065A (Servo Control)
Q01,02	203 5 5000 53650	TR 2SC536 E, F
Q3,05 07	203 5 7340 86350	TR 2SD863 E, F
Q04,06 08	203 5 7350 76450	TR 2SB764 E, F

POWER SUPPLY P.C.B. Assy 131 0 4001 03090

Ref. No.	Parts Number	Description
	4 2349 21280	Fuse 250 mA
	4 2359 22930	Socket
	4 2372 00060	Receptacle

CAPACITORS

C01	C2JNRM473C	Polypropylene	0.047 μ F	125V	\pm 20%
C02	C1ERE-477A	Electrolytic	470 μ F	25V	
C03,04 05,06	C2HYDP103A	Ceramic	0.01 μ F	500V	+100,-0%

Ref. No.	Parts Number	Description
----------	--------------	-------------

RESISTORS

R01	R2EDZJ152APA	Carbon	1.5k	1/4W	\pm 5%
R02	R2EDZJ332APA	Carbon	3.3k	1/4W	\pm 5%
R03	R2EDZJ152APA	Carbon	1.5k	1/4W	\pm 5%
R04	R2EDZJ104APA	Carbon	100k	1/4W	\pm 5%
R05	R2EDZJ224APA	Carbon	220k	1/4W	\pm 5%
R06	R2EDZJ272APA	Carbon	2.7k	1/4W	\pm 5%
R07	R2EDZJ562APA	Carbon	5.6k	1/4W	\pm 5%
R08	R2EDZJ391APA	Carbon	390	1/4W	\pm 5%
R09,10	R2EDZJ154APA	Carbon	150k	1/4W	\pm 5%
R11	R2EDZJ823APA	Carbon	82k	1/4W	\pm 5%
R12	R2EDZJ104APA	Carbon	100k	1/4W	\pm 5%
R13	R2EDZJ101APA	Carbon	100	1/4W	\pm 5%
R14,15 16	R2EDZJ181APA	Carbon	180	1/4W	\pm 5%
R17,18 19	R2EDZJ104APA	Carbon	100k	1/4W	\pm 5%
R20,21 22	R2EDZJ4R7APA	Carbon	4.7	1/4W	\pm 5%
R23	R2EDZJ333APA	Carbon	33k	1/4W	\pm 5%

Ref. No.	Parts Number	Description
----------	--------------	-------------

SEMICONDUCTORS

D01	DDD-S1RBA20	Bridge Diode, S1RBA20
-----	-------------	-----------------------

RESISTORS

R01	R3AXB123A	Oxide Metal Film	12k	1W	\pm 5%
-----	-----------	------------------	-----	----	----------

MOTOR CONTROL P.C.BOARD

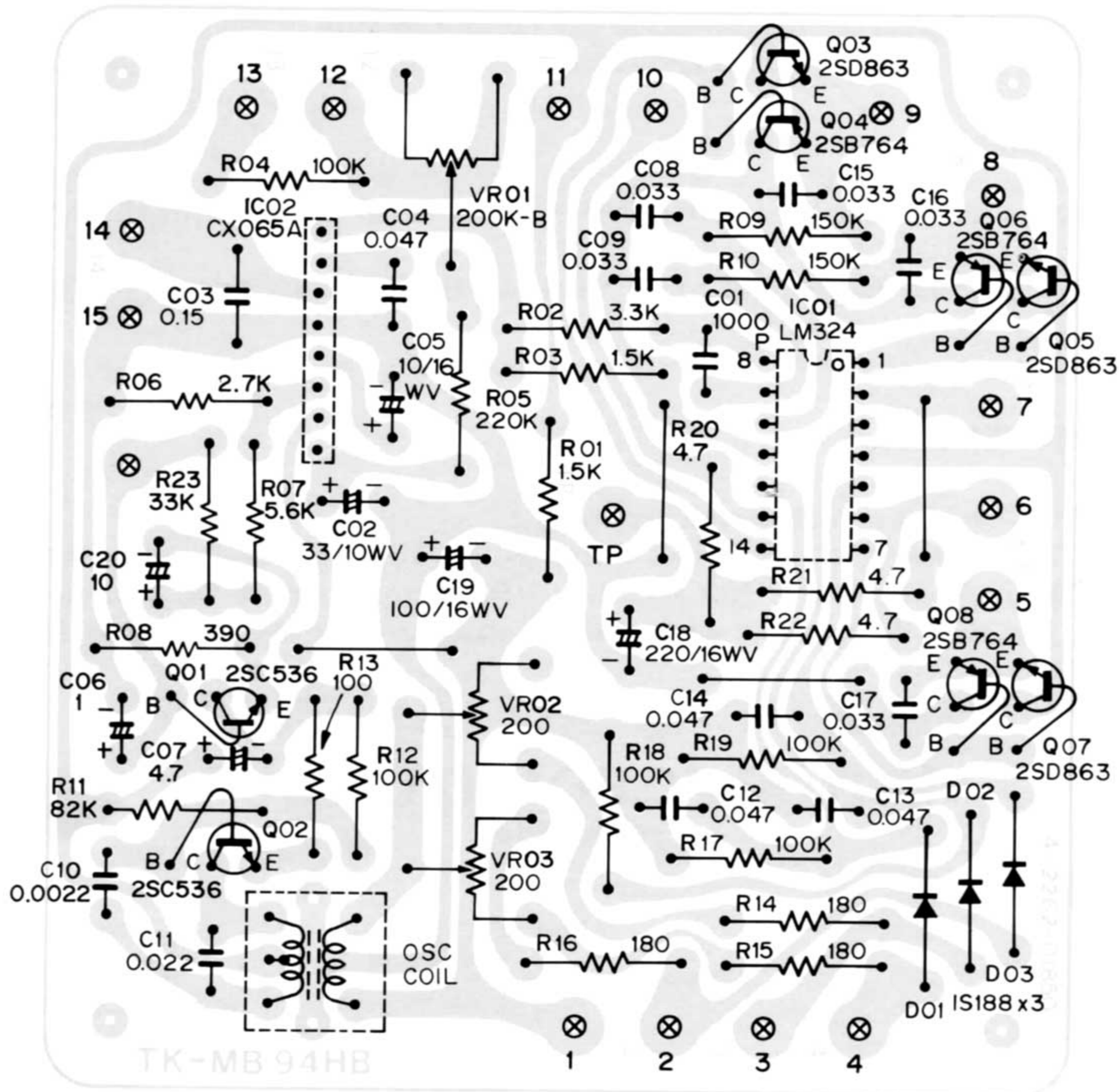

POWER SUPPLY P.C.BOARD

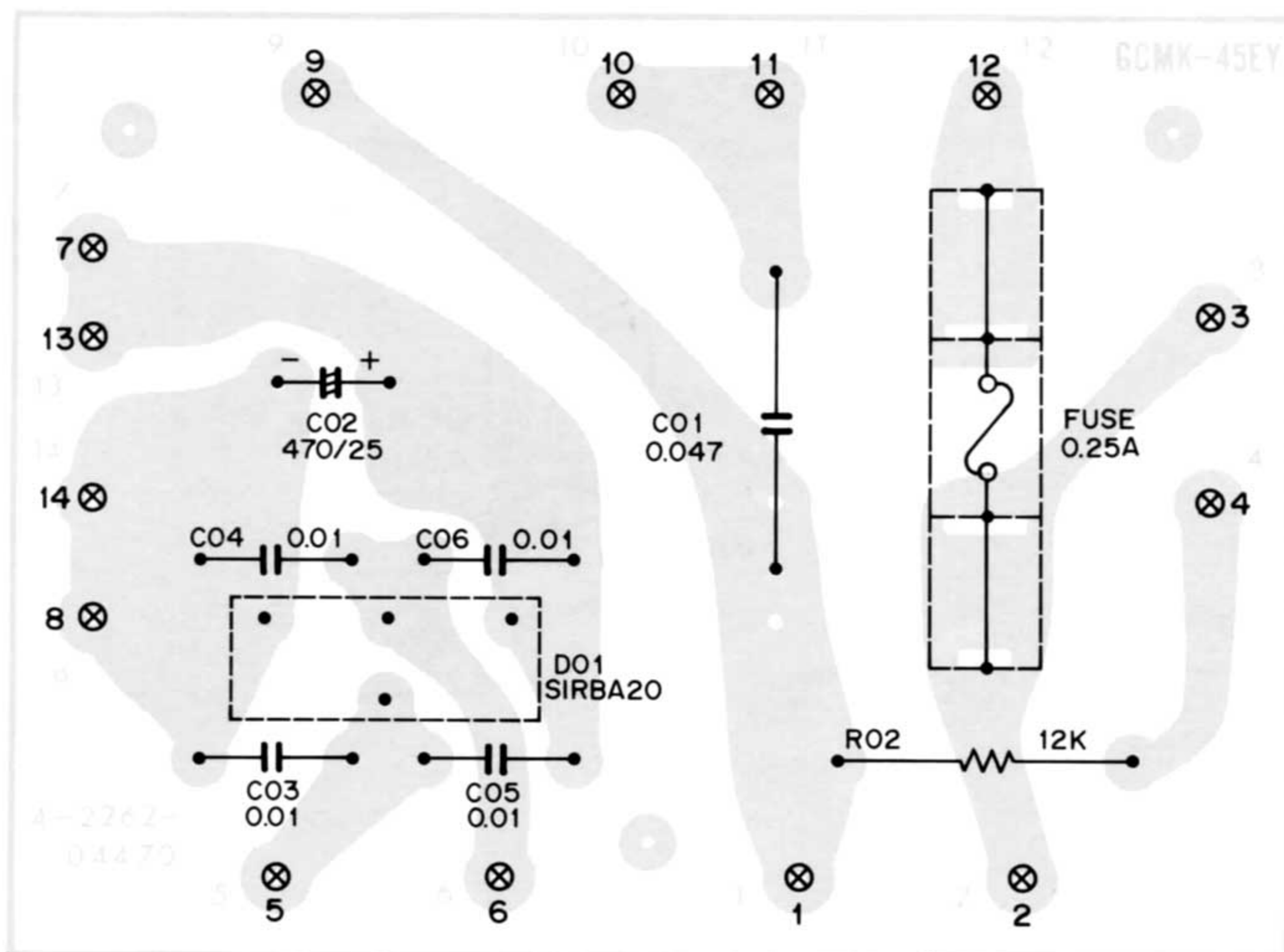

ELECTRICAL ADJUSTMENT

Although the two adjustments below are performed at the factory be sure to recheck each adjustment whenever the printed circuit boards are removed and repaired.

1. ROTATION ADJUSTMENT

- A. Place the unit horizontally and set the pitch control knobs (VR01,02 50k) to their mechanical center positions.
- B. Set the speed selector to 33 or 45 rpm and adjust VR01 (100K-B) for zero deviation by observing the stroboscope.

2. DC BALANCE ADJUSTMENT

- A. Remove the turntable. (The unit can be placed vertically.)
- B. Connect a DC VTVM between test points and terminal No. 10, and subsequently between test point and terminal No. 7. Adjust first VR03 and then VR02 for minimum DC voltage, the value measured should be less than 10 mV DC when simultaneously measured with two DC VTVM. (Fig. 1)

MOTOR P.C.BOARD LAYOUT (TOP VIEW)

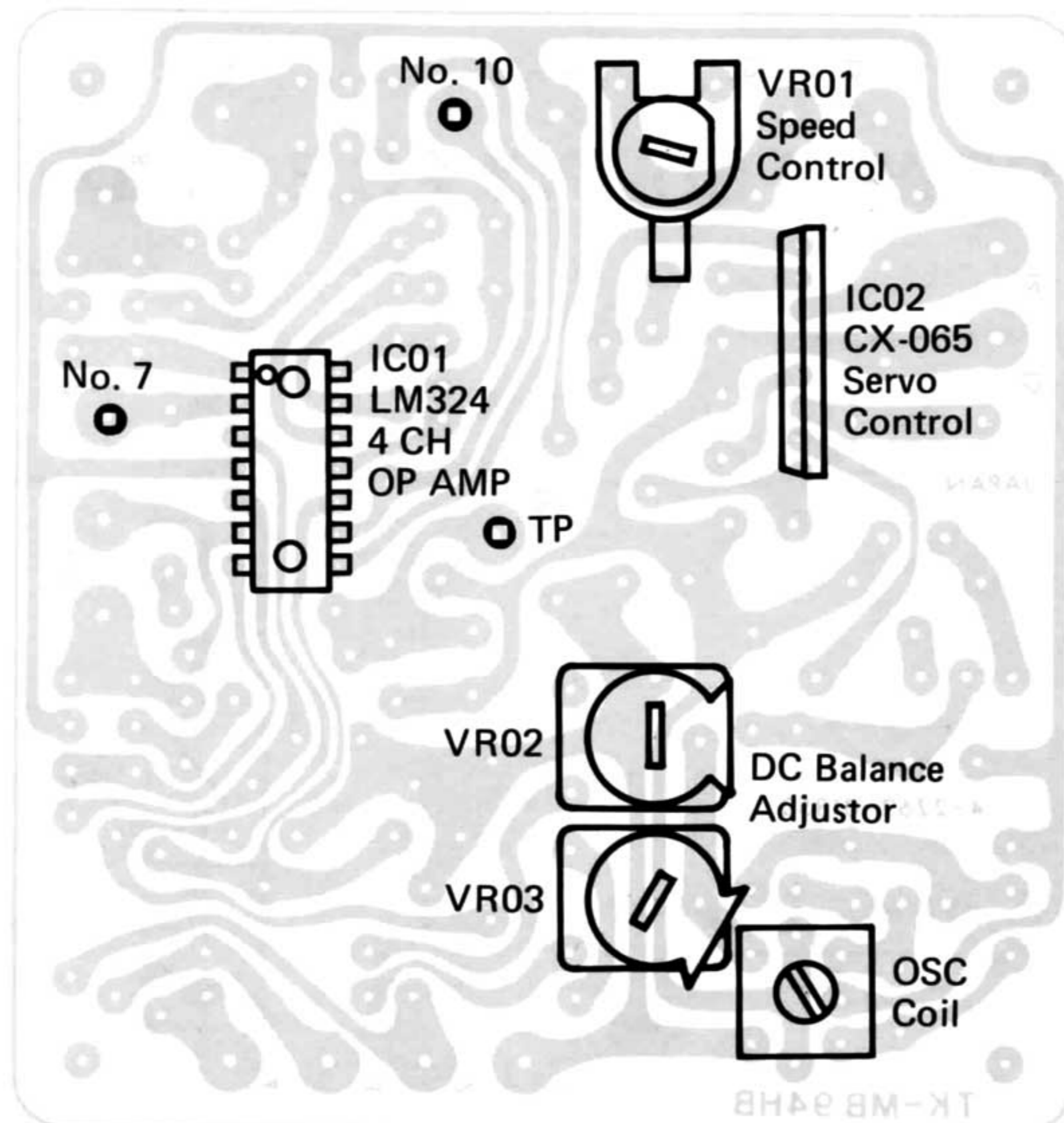

Fig. 1

MECHANICAL ADJUSTMENTS

PICK-UP ARM HEIGHT ADJUSTMENT

When using the cueing lever or the auto-return, perform the pick-up arm height adjustments by turning each adjusting screw as illustrated in Fig. 2.

Turn the adjusting screw clockwise to raise the Pick-up Arm, and counter-clockwise to lower it.

PICK-UP ARM RISING POSITION ADJUSTMENT (Return Point)

Change the return point either to inward or outward by turning the return adjusting cum (38).

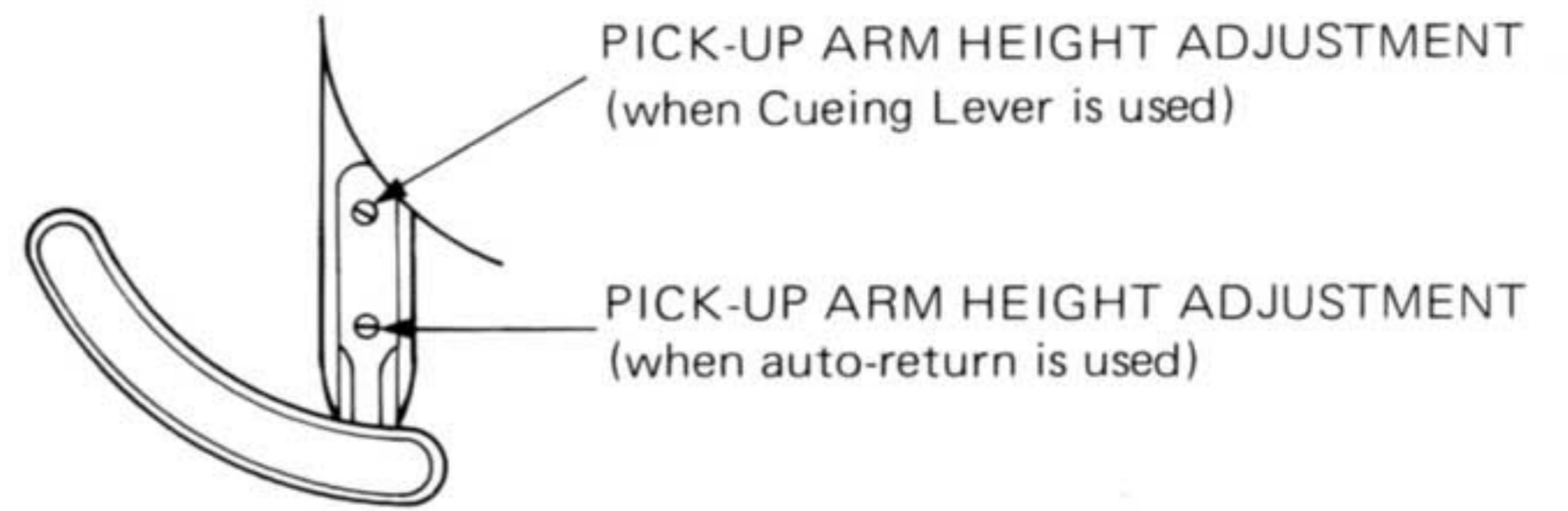

Fig. 2

MOUNTING THE CARTRIDGE

1. Carefully mount cartridge according to instructions given by the cartridge manufacturer. Do not tighten mounting screws as yet.

2. Connect the four colored wires found in the cartridge shell to the cartridge terminals. It is important that connections are made correctly. That is, colors of wires and cartridge terminals must be matched.

- Red = Right output
- Green = Right ground
- White = Left output
- Blue = Left ground

3. Plug cartridge shell into tone arm and tighten cartridge shell ring by turning it counterclockwise (as seen from shell side).

4. Move the tone arm over the overhang indicator and adjust cartridge until the stylus point is located exactly above the overhang indicator. Fix cartridge in this location by tightening mounting screws.

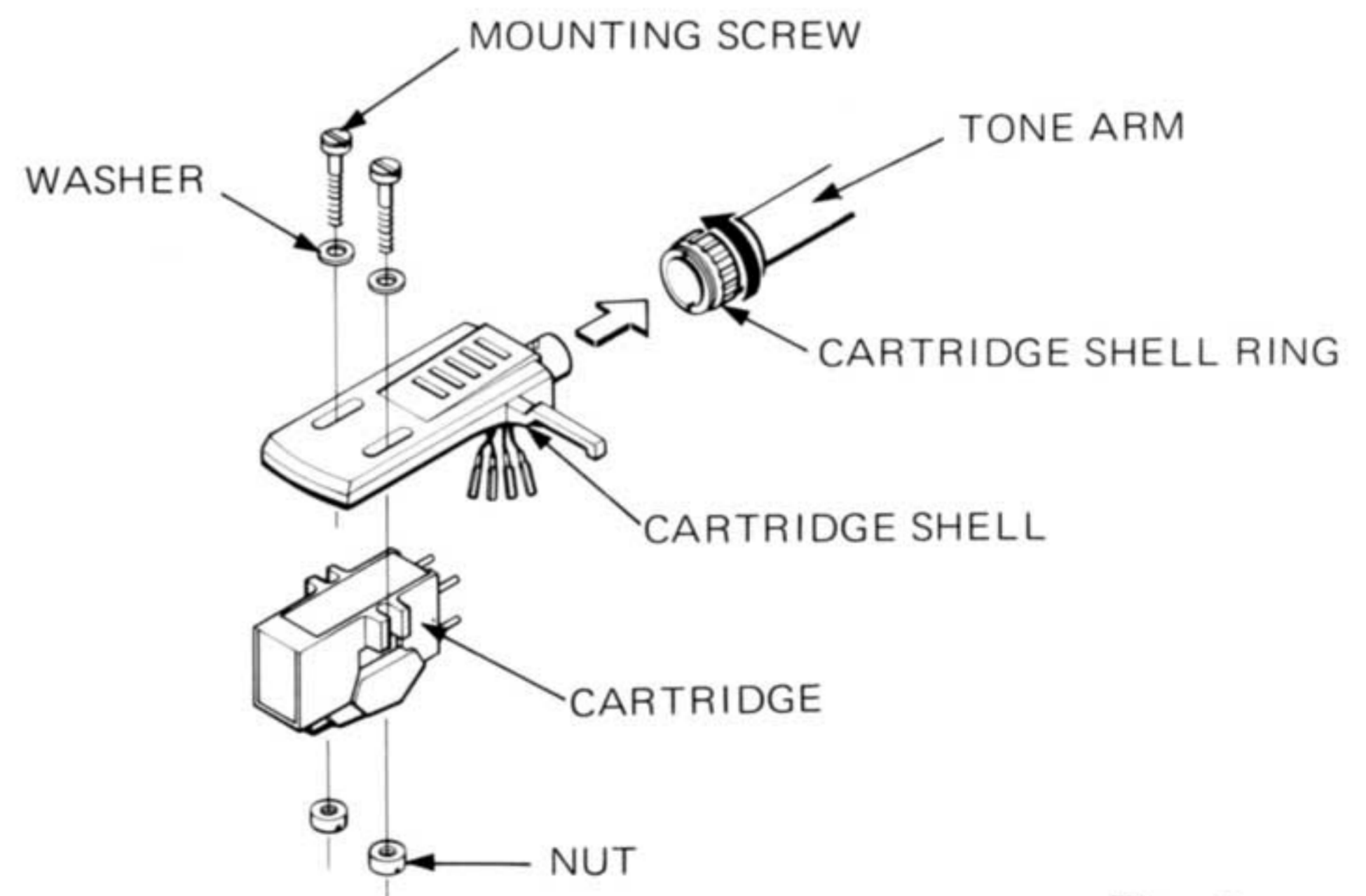

Fig. 3

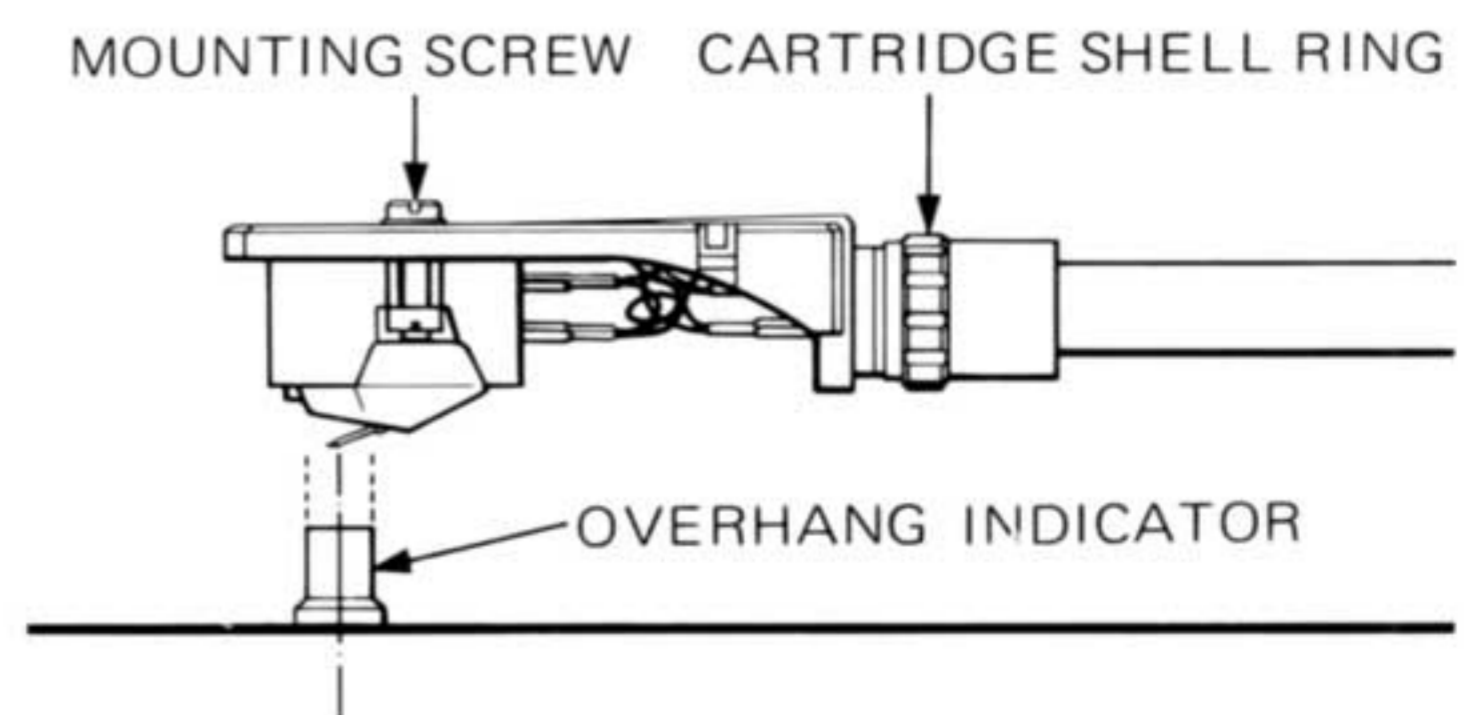
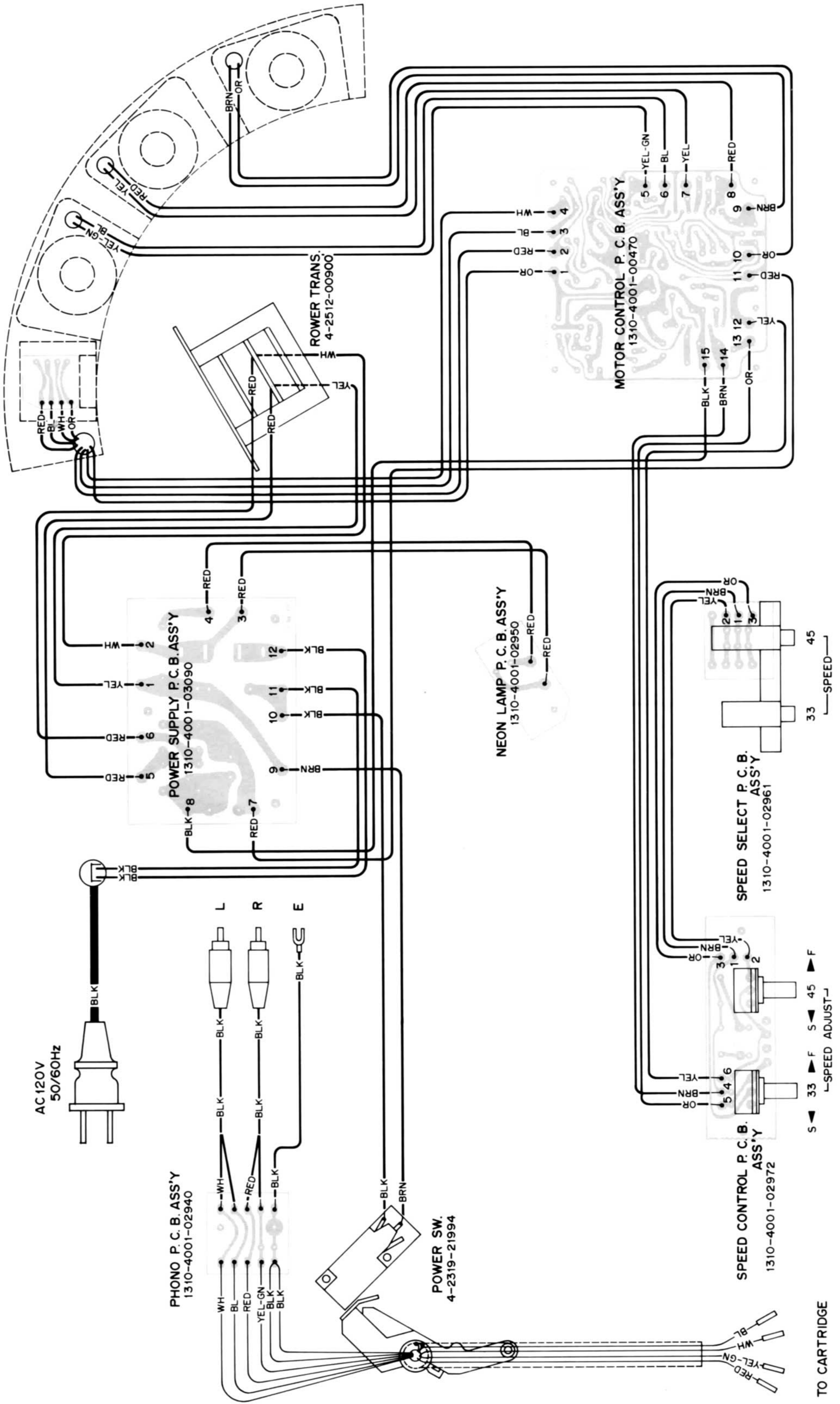
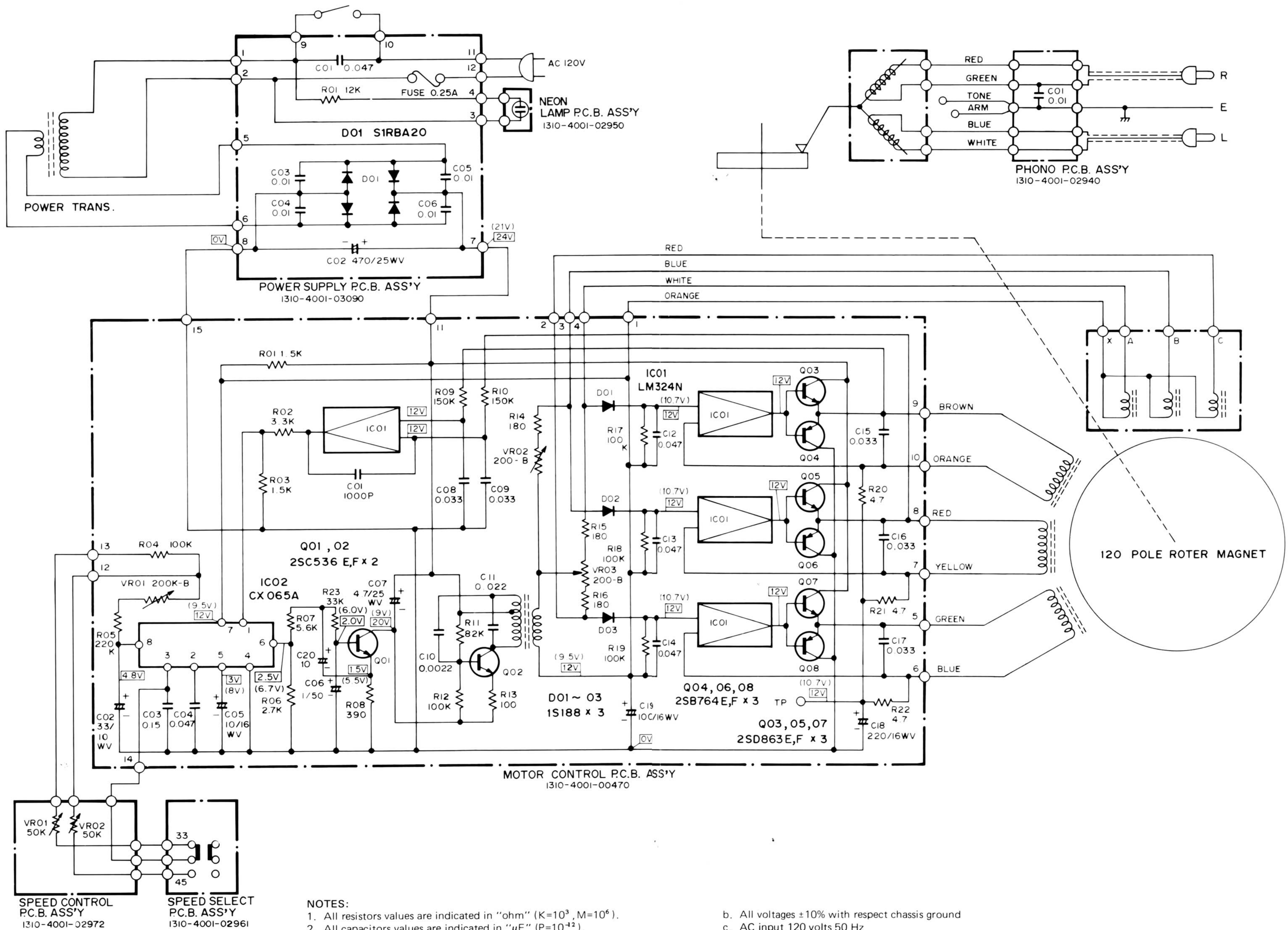

Fig. 4

POINT TO POINT WIRING DIAGRAM



SCHEMATIC DIAGRAM



NOTES:

1. All resistors values are indicated in "ohm" (K=10³, M=10⁶).
2. All capacitors values are indicated in "μF" (P=10⁻¹²).
3. All voltages indicated on the schematics are measured under the following conditions.
 - a. Use a V.T.V.M.

- b. All voltages ±10% with respect chassis ground
- c. AC input 120 volts 50 Hz
4. This is a fundamental schematics diagram. Some products may be modified without notice.

EXPLODED VIEW OF TURNTABLE

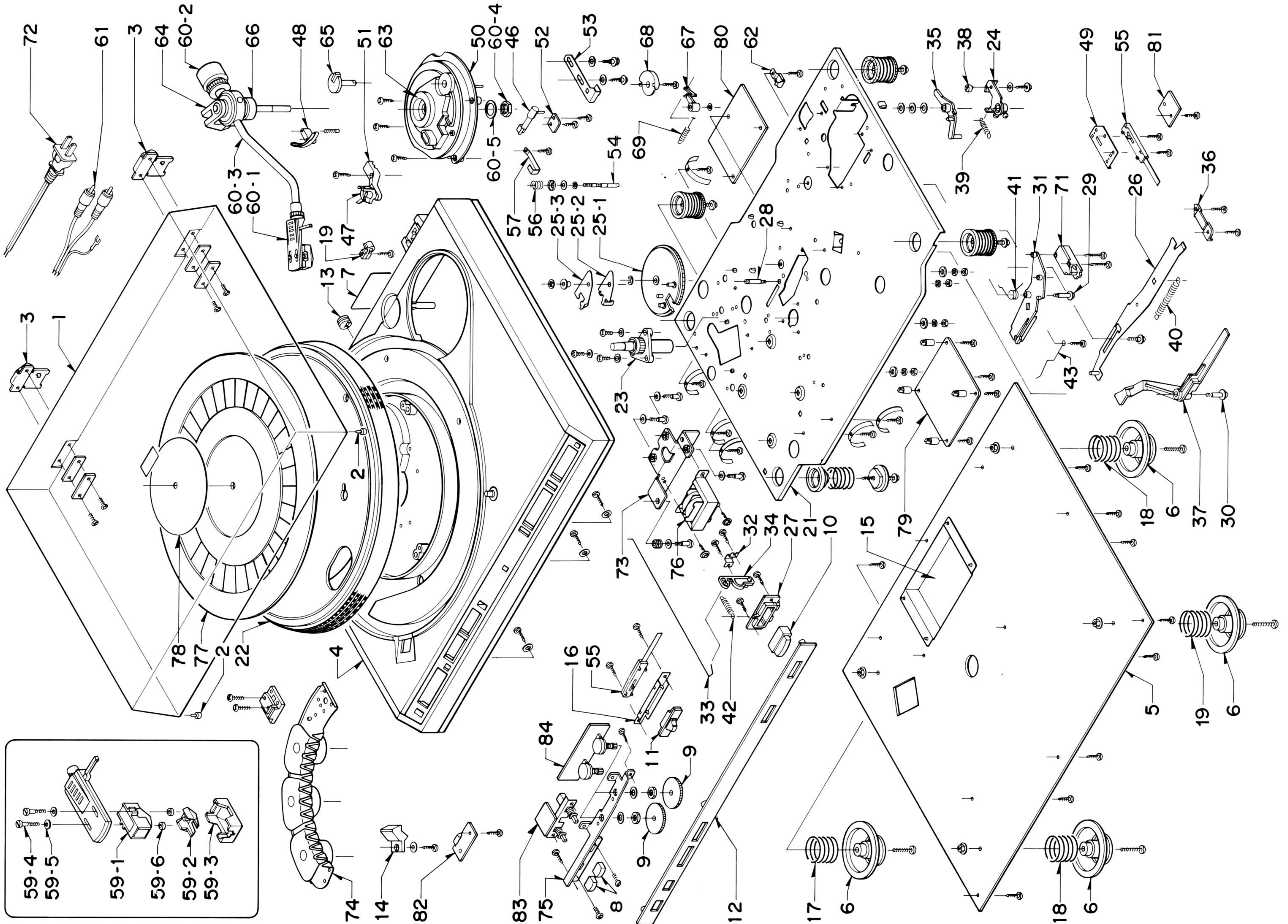

PARTS LIST (Continued)

TURNTABLE PARTS LIST

Ref. No.	Parts Number	Description	Ref. No.	Parts Number	Description
46	134 0 6019 10100	Cum Assy (Cueing Cum)	*	131 2 4201 20800	Screw 2.6x6
47	134 0 6031 11601	Arm Rest Assy			65 - 1
48	134 0 6042 10700	Plate Lifting Assy	*	131 2 4201 24405	Cap Screw
49	134 2 2403 22200	Angle Mount			64 - 1
50	134 2 3201 12700	Base Pick-up (Unit Plate)	*	102 3 2203 00601	Screw, Button Head Tapping
51	134 2 3301 13500	Arm Rest (Base Pick-up)			3.0x6 62 - 1, 81 - 1
52	134 2 4108 24600	Plate	71	4 2319 21994	Switch Micro (Power Switch)
53	134 2 4108 24700	Plate (Cueing Plate)	72	4 2439 20720	Power Cord
54	134 2 4116 13200	Spindle Lifting	73	131 2 3617 17500	Metal Mount Transformer
55	134 2 4129 10400	Joint (Angle Mount)	74	134 0 5011 00702	Motor Assy (Linear)
*	134 2 4213 10800	Washer Bowl	75	134 2 2403 22000	Angle Mount (Front Panel)
		51 - 1	*	104 3 1104 00003	Net, Hex Head 4.0
56	134 2 5101 27300	Spring (Lifter Spring)			74 - 3
57	134 2 5103 11000	Spring Plate (Cueing Spring)	*	101 3 1103 00603	Screw, Pan Head 3.0x6
*	104 3 1102 60000	Nut, Hex Head 2.6			71 - 2
		47 - 1	*	131 2 4201 18000	Screw
*	108 3 1102 00003	Ring E 2.0			73 - 2
		54 - 1	*	131 2 4201 19503	Screw (Screw, Button Head Tapping
*	131 2 4201 20703	Screw (Screw, Binding Head Tapping			B-TITE 3) 75 - 2
		B-TYTE 3) 47 - 1	*	131 2 4201 19505	Screw (Screw, Button Head Tapping
*	102 3 2203 00601	Screw, Button Head Tapping			B-TITE 3) 71 - 2
		3.0x6 49 - 2	*	131 2 4203 83201	Washer, Plain 3.2x10x0.5
*	102 3 1203 01007	Screw, Pan Head Tapping			73 - 4
		3.0x10 50 - 4	*	131 2 4203 84500	Washer, Plain 4.5x10x0.8
*	131 2 4201 19500	Screw (Screw, Button Head Tapping			74 - 3
		B-TITE 3) 57 - 1	*	105 3 1204 00001	Washer, Spring 4.0
*	131 2 4201 19501	Screw (Screw, Button Head Tapping			74 - 3
		B-TITE 3) 52 - 2	76	4 2512 00900	Power Transformer
*	131 2 4201 21000	Screw	77	134 2 6102 15200	Mat Turntable
		53 - 2	78	134 2 6103 11503	Plate Decorate T.T.
*	105 3 1202 60003	Washer, Spring 2.6	79	* 131 0 4001 00470	Motor Control P.C.B. Assy
		47 - 1	80	* 131 0 4001 03090	Power Supply P.C.B. Assy
*	131 2 4203 13702	Washer (Polyethylene)	81	* 131 0 4001 02940	Phono P.C.B. Assy
		53 - 2	82	* 131 0 4001 02950	Neon Lamp P.C.B. Assy
*	131 2 4203 83201	Washer, Plain 3.2x10x0.5	83	* 131 0 4001 02961	Speed Select P.C.B. Assy
		54 - 1	84	* 131 0 4001 02972	Speed Control P.C.B. Assy
59	→ 4 1579 21271	Pick-up Assy			
60	→ 134 0 4001 07800	Tone Arm Assy			
60-1	→ 134 0 4002 12200	Arm Head Assy			
60-2	→ 134 0 4003 01900	PU Weight Assy			
60-3	→ 134 0 4004 02800	Arm Assy			
60-4	→ 134 2 4202 11501	Nut			
60-5	→ 134 2 4203 02301	Washer			
59-1	→ 4 1579 26690	Cartridge (MG-35V)			
59-2	→ 4 1579 29210	Pick-up Stylus (ST-35VD)			
59-3	→ 134 2 1402 12100	Retainer Needle			
59-4	→ 134 2 4201 11310	Screw (-) 2.6x9			
59-5	→ 134 2 4203 01800	Washer			
59-6	→ 134 2 4202 11301	Nut			
61	131 0 4004 14402	Wire Shield Assy			
62	131 2 3608 14300	Cramp Wire (Phono Cord)			
63	134 2 1401 00200	Ring Decorate (PU Base)			
64	134 2 1404 12800	Housing (Tone Arm Housing)			
65	134 2 1601 18100	Knob (IFC Knob)			
66	134 2 2106 11500	Holder (Tone Arm Holder)			
67	134 2 4123 18700	Arm (IFC Arm)			
68	134 2 4124 11700	Cum (IFC Cam)			
69	134 2 5101 30700	Spring (IFC Spring)			
*	131 2 4220 10502	Ring Snap			
		67 - 1			

Note: * Asterisk indicates not a service part. The numbers for screws, nuts, and washers, shown in Description, correspond with Ref. Nos. of the parts using these screws, nuts and washers.

Example: 3 - 2

3 means	Ref. No.
2 means	Q'ty.

PARTS LIST

PACKING PARTS LIST

Ref. No.	Parts Number	Description
	131 6 1139 79405	Box Corrugate-EXP
	131 6 2119 01362	Bag Polyethylene-EXP (Cabinet)
	131 6 2119 01690	Bag Polyethylene-EXP (Lid)
	131 6 2519 00203	Bag Polyethylene-IND (T.T. Mat)
	131 6 2519 01300	Bag Polyethylene-IND
	131 6 3009 27520	Pad (Lid Top)
	131 6 3009 29180	Pad (Right)
	131 6 3009 29190	Pad (Left)

ACCESSORIES PARTS LIST

Ref. No.	Parts Number	Description
	131 6 2719 10801	Bag Fan
	131 6 4119 77901	Explanatory Booklet
	131 6 4519 14400	Guarantee Card
	134 2 2901 10700	Adapter EP

CABINET PARTS LIST

Ref. No.	Parts Number	Description
1	131 0 2022 90221	Lid Assy
2	131 2 2904 13000	Pad Lid
3	131 0 2002 15000	Hinge Assy (Lid)
4	131 2 1101 41801	Cabinet
5	131 2 1105 24502	Plate Bottom
6	131 0 1003 13500	Leg (Plate Bottom)
7	131 2 1310 30222	Name Plate (MT-6330)
	131 2 1310 30234	Name Plate (MT-6330C)
8	131 2 1601 58800	Knob (Speed Select)
9	131 2 1601 58900	Knob (Speed Adjust)
10	131 2 1601 59000	Knob (Reject)
11	131 2 1601 59100	Knob (Cueing)
12	131 2 3305 26803	Front Panel
13	131 2 6111 21300	Bushing (SR-4P-4)
14	131 2 6308 18101	Filter (Strobo Filter)
15	134 2 1102 00400	Cover
16	134 2 2403 22100	Angle Mount (Cueing Angle)
17	134 2 5102 13900	Spring Mounting (Leg Assy, Left-Rear)
18	134 2 5102 13901	Spring Mounting (Leg Assy)
19	134 2 5102 13902	Spring Mounting (Leg Assy, Right-Front)
20*	131 2 3608 11000	Cramp Wire (Phono Cord)
*	131 2 4202 12900	Flange Nut 6 - 4
*	101 3 1103 01402	Screw, Pan Head 3.0x14 6 - 4
*	101 3 1504 01002	Screw, Truss Head 4.0x10 3 - 4
*	131 2 4201 19500	Screw (Screw, Button Head Tapping B-TITE 3) 14 - 1
*	131 2 4201 19502	Screw (Screw, Button Head Tapping B-TIPE 3) 12 - 2
*	131 2 4201 19504	Screw (Screw, Button Head Tapping B-TITE 3) 19 - 1
*	131 2 4201 19505	Screw (Screw, Button Head Tapping B-TITE 3) 5 - 10
*	131 2 4201 19502	Screw (Screw, Button Head Tapping B-TIPE 3) 16 - 2

Ref. No.	Parts Number	Description
*	134 2 4203 02700	Washer 6 - 4
*	131 2 4203 83202	Washer, Plain 3.2x10x1.0 14 - 1, 12 - 2

TURNTABLE PARTS LIST

Ref. No.	Parts Number	Description
*	131 2 4201 21800	Screw 21 - 4
21	134 2 2101 13900	Unit Plate
22	134 0 5001 12901	Turntable
23	134 0 9902 11401	Assembly Plan
	131 2 4201 13502	Screw (TAPTITE) 3x8
24	134 0 6022 12202	Plate PU Fix Assy
25	134 0 6030 11301	Gear Cycling Assy
25-1	134 2 4110 11100	Gear Cycling
25-2	134 2 4122 11800	Trip
25-3	134 2 4122 12000	Trip
26	134 0 6035 11600	Return Plate Assy
27	134 2 2403 21800	Angle Mount (Reject Angle)
28	134 2 4106 19900	Shaft (Gear Shaft)
29	134 2 4106 22200	Shaft (Switch Plate)
30	134 2 4106 22201	Shaft (Return Arm)
31	134 2 4108 21000	Plate (Switch Plate)
32	134 2 4108 24500	Plate (Reject Angle)
33	134 2 4112 01200	Rod (Reject Rod)
34	134 2 4120 18200	Lever (Reject Lever)
35	134 2 4120 18300	Lever (Pick-up)
36	134 2 4121 11800	Guide (Return Plate)
37	134 2 4123 19100	Arm (Return Arm)
38	134 2 4124 12200	Cum (Return Adjust)
39	134 2 5101 20500	Spring (Pick-up)
40	134 2 5101 24600	Spring (Return Plate)
41	134 2 5101 26400	Spring (Switch Plate)
42	134 2 5101 28000	Spring (Reject)
43	134 2 5101 28600	Spring (Trip Return)
*	104 3 1203 00002	Nut, Hex Head 3.0 28 - 1
*	108 3 1104 00000	Ring E 4.0 28 - 1
*	101 3 1103 00603	Screw, Pan Head 3.0x6 24 - 2
*	131 2 4201 21100	Screw 38 - 1
*	131 2 4201 19501	Screw (Screw, Button Head Tapping B-TITE 3) 32 - 2
*	131 2 4201 19502	Screw (Screw, Button Head Tapping B-TIPE 3) 32 - 2
*	131 2 4201 13511	Screw (TAPTITE) 3x14 31 - 1
*	102 3 2203 00601	Screw, Button Head Tapping 3.0x6 36 - 2, 44 - 1
*	105 3 1203 00002	Washer, Spring 3.0 28 - 1
*	131 2 4203 17501	Wave Washer 38 - 1