

2245

MT-730

SERVICE MANUAL



FISHER®

MT-730

Stereo Turntable



- 134 080 20
(Lid Supplied, Black)
- 134 080 21
(Without Lid, Black)
- 134 080 22
(Lid Supplied, Silver)

U.S.

CONTENTS

Arm Feed Cord Stringing	2
Specifications	3
Cabinet & Chassis Exploded View	4,5,6
Cabinet & Chassis Parts List	7,8
Turntable Adjustments	9,10
Printed Circuit Board (Bottom View)	11,12,13,14
P.C.Board Parts List	15,16
IC Signal Flow & Equivalent Circuit	17
Semiconductor Lead Identification	18
Schematic Diagram	19,20
Point to Point Wiring Diagram	21,22
Caution of Usage for Motor	23
Caution of Usage for IC03	23

ARM FEED CORD STRINGING

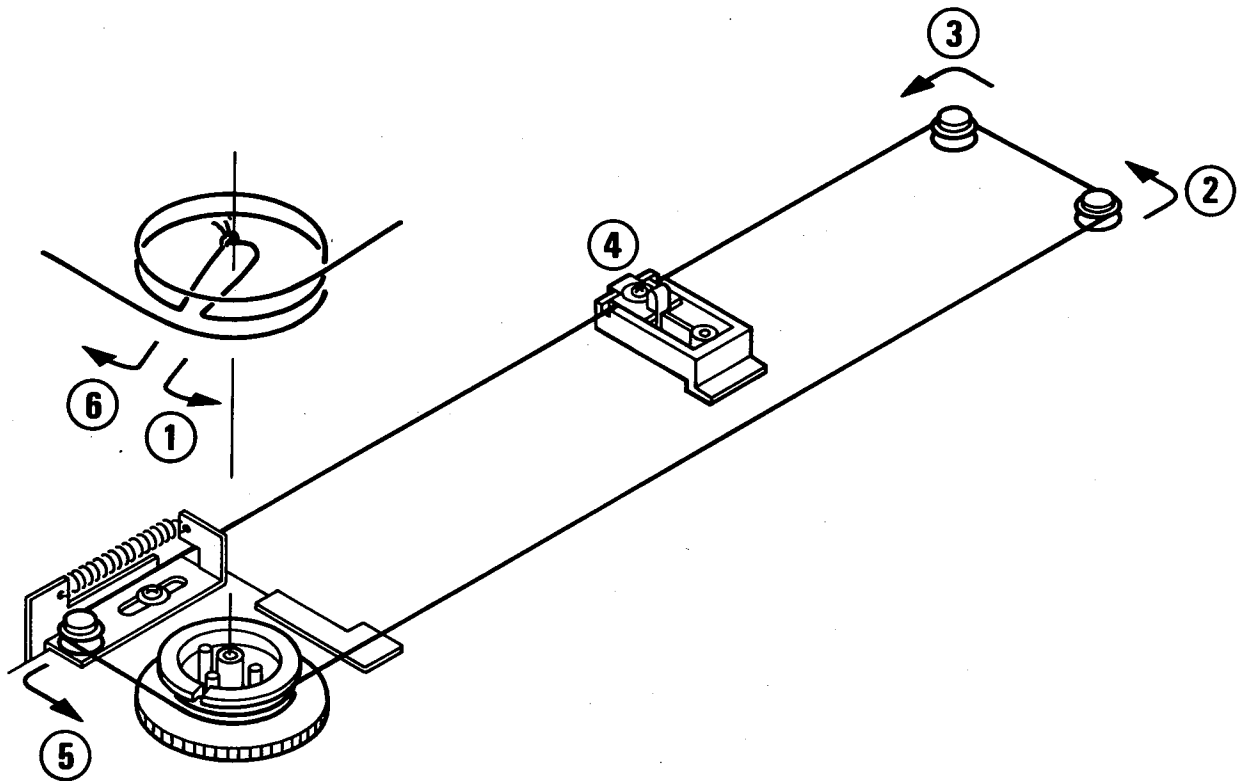

SPECIFICATIONS

TURNTABLE	MT-730
Motor	FG Servo
Drive System	Belt
Wow and Flutter (WRMS)	0.035 %
Rumble (DIN 45539B)	-70 dB
Speed Variation	±1.5 %
Tracking Force	2 g
Platter Diameter	310 mm
Platter Weight	0.6 kg
Record Speed Selector	33-1/3 rpm/ 45 rpm
Automatic Functions	
Start	Yes
Repeat	Yes
Reject	Yes
Automatic Tonearm Return at End of Record	Yes
Manual Function	
Start	Yes
Stop	Yes
Tonearm Data	
Resonance	<18 Hz
Effective Length	130 mm
Shape	Straight
Bearing Type	
Horizontal Friction Sensitivity	Pivot 0.15 g
Vertical Friction Sensitivity	Pivot 0.2 g
Max. Tracking Error	±0.2°
GENERAL	
Power Requirements	120 V AC ±10 % 50/60 Hz
Power Consumption	10 Watts
Dimensions (W x H x D)	17.33" x 4.5" x 14.5"
Weight (approx.)	10.5 lbs.

Because its products are subject to continuous improvement, Fisher Corporation reserves the right to modify product designs and specifications without notice and without incurring any obligation.

CABINET & CHASSIS EXPLODED VIEW

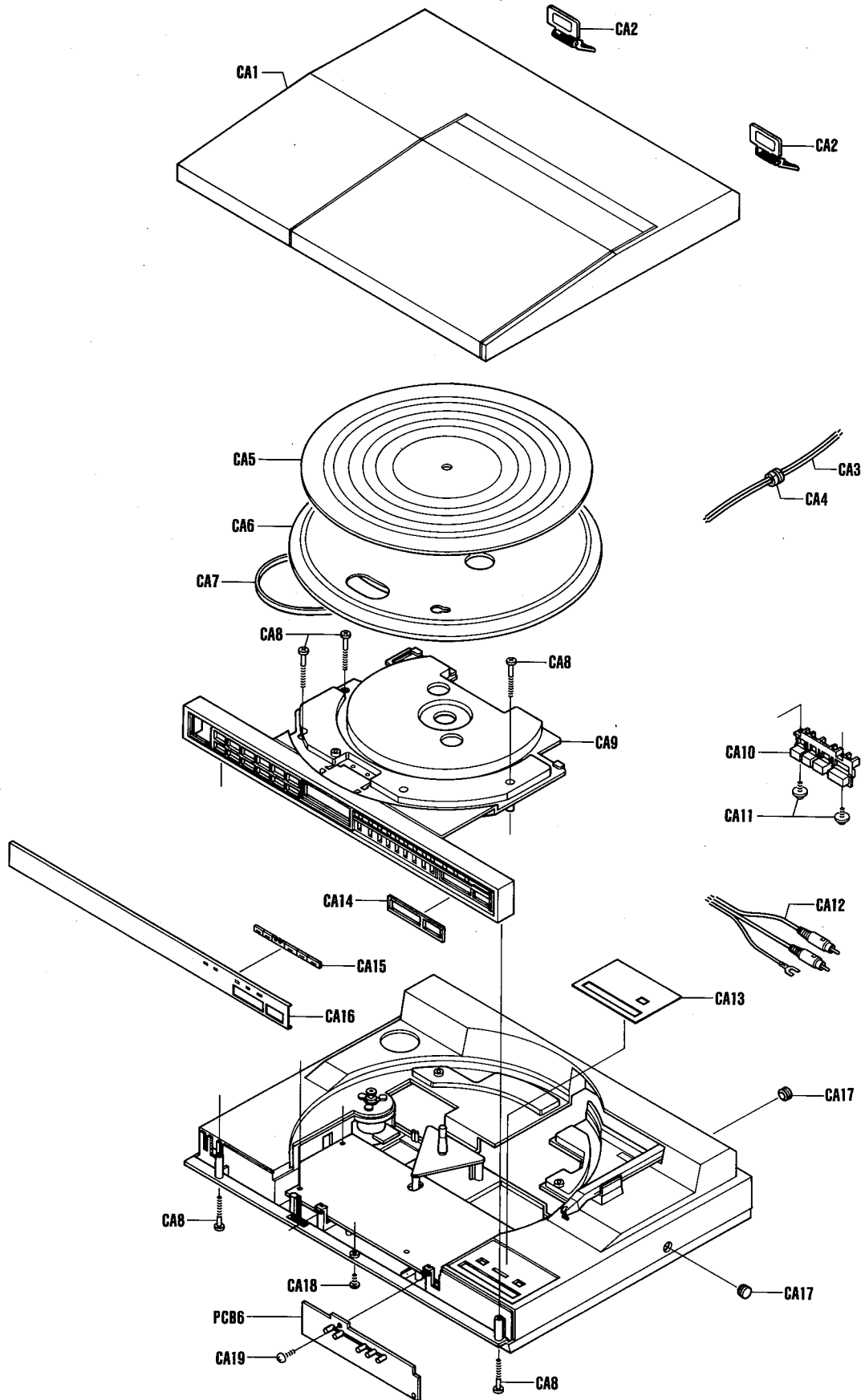

CABINET & CHASSIS EXPLODED VIEW (Continued)

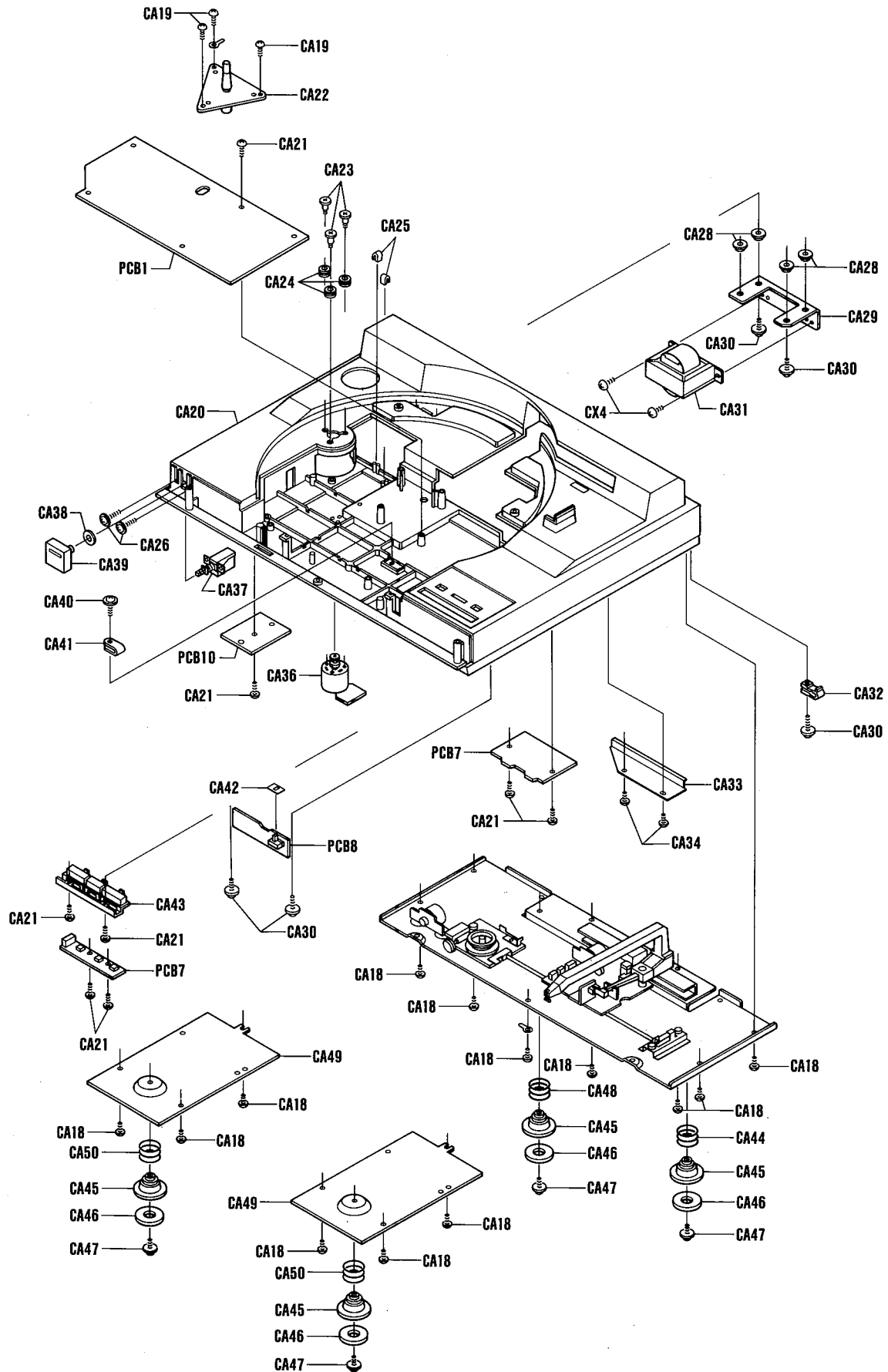

CABINET & CHASSIS EXPLODED VIEW (Continued)

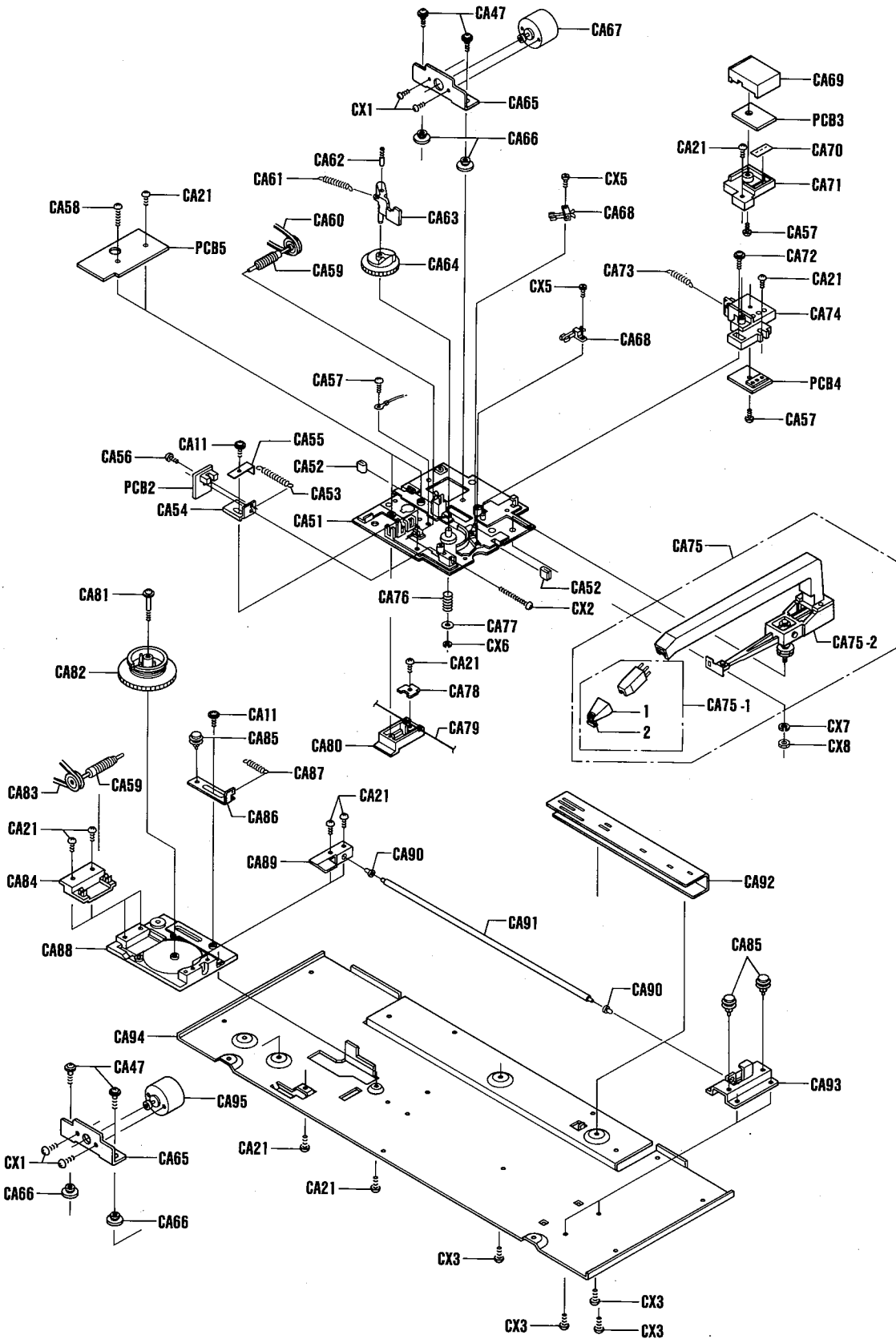

CABINET & CHASSIS PARTS LIST

Ref. No.	Part No.	Description	Q'ty	Ref. No.	Part No.	Description	Q'ty
PACKAGE				CA19	131 2 4201 23703	Screw	4
131 6	2519 00201	Bag Polyethylene Ind	1	CA20	141 2 1129 08800	Cabinet (Black)	1
131 6	3069 17050	Patching Sheet	1	CA20	141 2 1129 08802	Cabinet (Silver)	1
131 6	4159 10106	Notes	1	CA21	131 2 4201 19501	Screw, Button Hd. Tapping	17
134 2	2104 12300	Screw Transit(+,-)	3	CA22	141 0 7519 03900	Shaft Turntabl Compl.	1
134 2	4208 15100	Spacer	3	CA23	134 2 4201 13600	Screw	3
141 2	4219 32700	Screw Transit	1	CA24	134 2 5202 11800	Rubber Cushion	3
141 6	1139 98300	Box Corrugate-exp (lid supplied, Black)	1	CA25	134 2 5205 12000	Cushion	2
141 6	1139 98301	Box Corrugate-exp (without lid, Black)	1	CA26	131 2 4201 20300	Screw TP	2
141 6	1139 98304	Box Corrugate-exp (lid Supplied, Silver)	1	CA28	141 2 4459 31800	Cushion	4
141 6	2519 19490	Bag Polyethylene-exp	1	CA29	141 2 3719 06200	Metal Mount Trans	1
141 6	3119 23401	Pad	1	CA30	131 2 4201 25205	Screw	6
141 6	3119 24900	Pad Front	1	CA31	△ 4 2512 30500	Power Trans [T1]	1
141 6	3119 25000	Pad Rear	1	CA32	131 2 3608 12405	Cramp Wire	1
141 6	3119 25100	Pad (lid supplied, Black/Silver)	1	CA33	141 2 1149 39400	Cover	1
141 6	3119 25200	Pad PU (without lid, Black)	1	CA34	131 2 4201 20801	Screw, +M2.6x8	2
141 6	4559 03300	Serial No. Sheet	2	CA36	134 0 5011 02803	Motor Assy [M1]	1
ACCESSORIES				CA37	△ 4 2312 06051	Switch Push Power [S4]	1
131 6	2719 10801	Bag Fan	1	CA38	131 2 4203 84507	Washer Plain, M4.5x10x0.5	1
131 6	4159 34100	Notes	1	CA39	131 2 1601 85202	Knob Power (Black)	1
131 6	4319 10802	Service Station List	1	CA39	131 2 1601 85200	Knob Power (Silver)	1
131 6	4519 14400	Warranty Card	1	CA40	131 2 4201 25203	Screw, Brazier Hd. Tapping, +M3.0x16	1
131 6	4939 00200	Customer Card	1	CA41	131 2 3608 11000	Cramp Wire	1
134 2	2901 11601	Adapter EP	1	CA42	141 2 4419 21100	Cloth	1
142 6	4119 32082	Explanatory Booklet	1	CA43	141 2 1659 35700	Knob	1
CABINET				CA44	141 2 8559 06501	Spring Mounting	1
	4 2359 75220	Connector 12P Assy [CN1]	1	CA45	141 2 4459 31700	Cushion(Leg)	4
	4 2359 76794	Connector 3P Assy [CN9]	1	CA46	131 2 5203 23603	Felt	4
	4 2359 77145	Connector 1P Assy (Terminal PCB)	1	CA47	134 2 4201 13400	Screw	8
	4 2359 77345	Connector 4P Assy [CN2]	1	CA48	141 2 8559 06506	Spring Mounting	1
	4 2359 77572	Connector 1P Assy (Control PCB)	1	CA49	141 2 1259 07300	Plate Bottom	2
131 2	1310 34625	Name Plate	1	CA50	141 2 8559 06505	Spring Mounting	2
131 2	7103 48800	Label	1	CA51	141 0 3129 01900	Unit Plate Assy	1
131 2	7103 26100	Label	1	CA52	141 2 4459 33800	Cushion	2
131 2	3608 14100	Cramp Wire	6	CA53	141 2 8519 31900	Spring, Slide Base	1
134 6	4739 13403	Stylus Label	1	CA54	141 2 3519 67400	Angle Mount(Photo C)	1
141 6	4559 03300	Serial No. Sheet	1	CA55	141 2 8539 53800	Spring Plate	1
CA1	141 0 1249 30600	Lid Assy (lid supplied, Black)	1	CA56	131 2 4201 20800	Screw, +M2.6x6	1
CA1	141 0 1249 30601	Lid Assy (lid supplied, Silver)	1	CA57	131 2 4201 19500	Screw, Button Hd. Tapping	3
CA2	131 0 2002 16800	Hinge Assy (lid supplied, Black)	2	CA58	131 2 4201 19504	Screw, Button Hd. Tapping	1
CA2	131 0 2002 16803	Hinge Assy (lid supplied, Silver)	2	CA59	141 0 5519 10300	Worm Assy	2
CA3	△ 4 2432 00040	Power Cord	1	CA60	141 2 5649 22600	Belt	1
CA4	131 2 6111 21300	Bushing	1	CA61	141 2 8519 60000	Spring Plate	1
CA5	134 2 6102 15701	Mat Turntable	1	CA62	134 2 4201 12800	Screw	1
CA6	141 2 5229 00402	Turntable	1	CA63	141 2 7519 64000	Spindle Lifting	1
CA7	134 2 6302 11500	Belt	1	CA64	141 2 5519 52100	Worm Wheel(A)	1
CA8	131 2 4201 20702	Screw, +M3.0x35	5	CA65	141 2 3519 67100	Angle Mount(Motor)	2
CA9	141 2 1219 29500	Panel Front (Black)	1	CA66	141 2 4459 31800	Cushion	4
CA9	141 2 1219 29501	Panel Front (Silver)	1	CA67	4 5272 00181	Comutate MTR Magnet (Arm) [M3]	1
CA10	141 2 1659 35800	Knob	1	CA68	4 2319 76680	Leaf Switch (Lift Down) [S2]	1
CA11	131 2 4201 21100	Screw	4	CA68	4 2319 76680	Leaf Switch (Lift Up) [S3]	1
CA12	131 0 4004 14403	Wire Shield Assy	1	CA69	141 2 3519 66900	Cover(Holder)	1
CA13	141 2 1439 14000	Panel Control (Black)	1	CA70	141 2 3519 67500	Plate(Filter)	1
CA13	141 2 1439 14001	Panel Control (Silver)	1	CA71	141 2 3519 66800	LED Holder	1
CA14	131 2 6113 51000	Shelter	1	CA72	141 2 4219 06300	Screw	1
CA15	141 2 1329 14400	Filter	1	CA73	134 2 5101 32400	Spring	1
CA16	141 2 1439 14101	Panel Control	1	CA74	141 2 3519 67000	LED Holder Base	1
CA17	131 2 2904 11000	Pad Lid (Black)	2	CA75	141 0 6419 01000	Pick-up Assy (Black)	1
CA17	131 2 2904 11001	Pad Lid (Silver)	2	CA75	141 0 6419 01001	Pick-up Assy (Silver)	1
CA18	131 2 4201 20705	Screw, Bdg Hd. Tapping	14	CA75-1	4 1579 27031	Cartridge(MG-37L)	1
				1	4 1579 29451	Stylus(ST-37LD)	1
				2	134 2 1402 12700	Retainer Needle	1
				CA75-2	141 0 6419 01100	Tone Arm Assy (Black)	1
				CA75-2	141 0 6419 01101	Tone Arm Assy (Silver)	1

CABINET & CHASSIS PARTS LIST (Continued)

Ref. No.	Part No.	Description	Q'ty
CA76	134 2 5101 26500	Spring	1
CA77	141 2 4579 05000	Washer, M3.2x10x0.2	1
CA78	141 2 3519 70300	Angle Mount	1
CA79	131 2 4112 10200	Rope	
CA80	141 2 7319 58000	Holder Slide	1
CA81	134 2 4106 27000	Shaft	1
CA82	141 2 5519 52200	Worm Whell(B)	1
CA83	141 2 5649 24700	Belt	1
CA84	141 2 5739 07000	Support Shaft	1
CA85	131 0 3020 11800	Pully Assy	3
CA86	141 2 3519 69000	Angle Mount	1
CA87	141 2 8519 33300	Spring Lock Caset Case	1
CA88	141 2 3169 23200	Frame	1
CA89	141 2 3519 69100	Angle Mount	1
CA90	141 2 4459 33200	Cushion	2
CA91	141 2 5289 01600	Rail	1
CA92	141 2 3169 22201	Guide Angle	1
CA93	141 2 3519 72200	Angle Mount	1
CA94	141 2 1259 07400	Plate Bottom	1
CA95	4 5272 00180	Comutate MTR Magnet (Lifter) [M2]	1
CX1	101 3 1302 00311	Screw, Pan Hd., +M2.0x3	4
CX2	101 3 1303 03011	Screw, Pan Hd., +M3.0x30	1
CX3	103 3 1303 00511	Screw, Pan Hd. Tapping-2, +M3.0x5	4
CX4	103 3 1904 00611	Screw, Brazier Hd. Tapping-2, +M4.0x6	2
CX5	143 3 1702 00818	Screw, Bind Hd. Tapping-B, +M2.0x8	2
CX6	112 3 1302 00011	E Ring, M2.0	1
CX7	110 3 2104 00011	Spring Washer-2, M4.0	1
CX8	106 3 1204 00311	Hex. Nut-2, M4.0	1
PCB1	141 0 1939 05390	Control P.C.B. Assy	1
PCB2	141 0 1939 02710	PCR P.C.B. Assy	1
PCB3	141 0 1939 02721	PTR P.C.B. Assy	1
PCB4	141 0 1939 02731	LED P.C.B. Assy	1
PCB5	141 0 1939 05470	Terminal P.C.B. Assy	1
PCB6	141 0 1939 05400	Switch LED P.C.B. Assy	1
PCB7	141 0 1939 05410	Switch P.C.B. Assy	1
PCB8	141 0 1939 05420	Speed Switch P.C.B. Assy	1
PCB9	141 0 1939 05430	Volume P.C.B. Assy	1
PCB10	141 0 1939 05450	Fuse P.C.B. Assy	1

NOTES:

1. Parts order must contain Model Number, Part Number and Description.
2. Ordering quantity of screws and resistors must be multiple of 10 pcs.

PRODUCT SAFETY NOTICE

Each precaution in this manual should be followed during servicing. Components identified with the IEC symbol Δ in the parts list and the schematic diagram designate components in which safety can be of special significance. When replacing a component identified with Δ , use only the replacement parts designated, or parts with the same ratings of resistance, wattage or voltage that are designated in the parts list in this manual. Leakage-current or resistance measurements must be made to determine that exposed parts are acceptably insulated from the supply circuit before returning the product to the customer.

TURNTABLE ADJUSTMENTS

Stylus Pressure Adjustment

1. Place the unit on a horizontal plane and remove the lid.
2. Turn on the Power switch of the unit.
3. Press \triangleleft button on the control panel to shift the tonearm to the place as indicated in Fig. 1.
4. Turn the stylus pressure adjustment screw as shown in Fig. 2 through the stylus pressure adjustment hole, so that the stylus pressure meter indicates $1.8 \sim 2.2$ g.

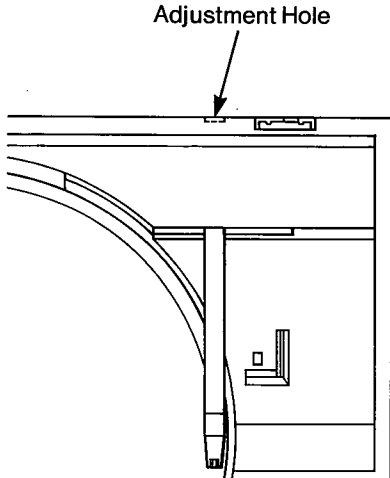

Fig. 1

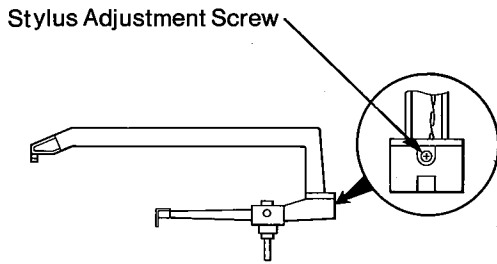

Fig. 2

Tonearm Position Adjustment

1. Turn on the power switch of the unit.
2. Remove the lid and the turntable.
3. Press \triangleleft button on the control panel to shift the arm to the place where the tonearm position adjustment cam can be observed. (Fig. 3)
4. Adjust the cam, so that the tonearm becomes perpendicular to the rear wall of the cabinet. (Fig. 3)

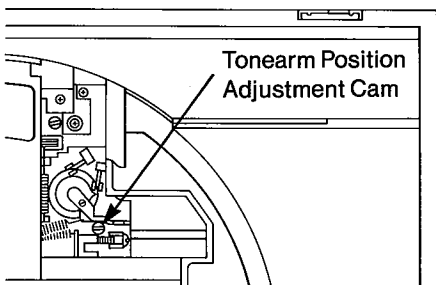

Fig. 3

Stylus Height Adjustment

1. Turn on the power switch of the unit.
2. Remove the lid and the turntable.
3. Press \triangleleft button on the control panel to shift the arm to the place where the stylus height adjustment screw can be observed. (Fig. 4)
4. Adjust the stylus height to $6\text{mm} \pm 0.5\text{mm}$ above the turntable.

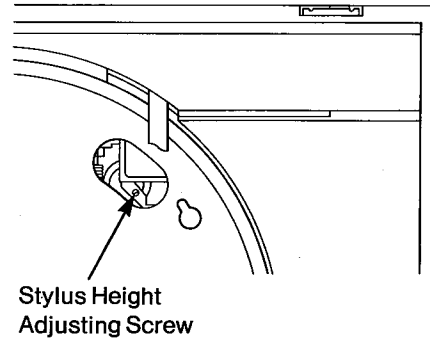

Fig. 4

Rotation Adjustment

1. Turn on the power switch of the unit.
 2. Use the stroboscope sheet and adjust each volume to obtain proper rotations per minute. (Fig. 5)
- Note: In the first instance, perform the adjustment for $33\text{-}1/3$ r.p.m.

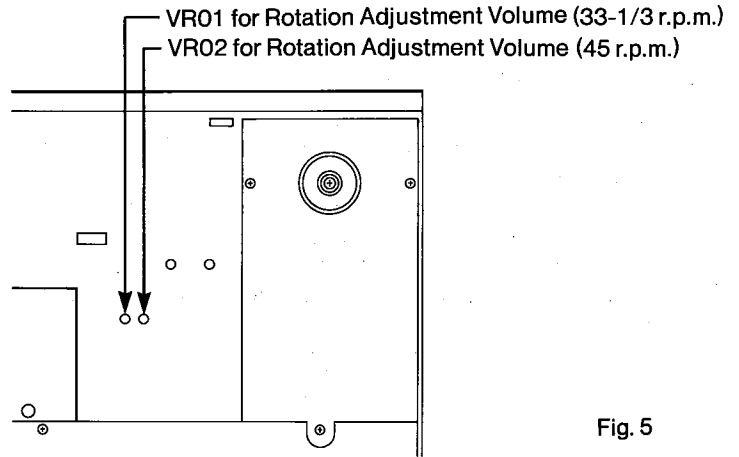

Fig. 5

Arm Trace Adjustment

1. Turn on the power switch of the unit.
2. Place a record on the turntable and trace the silent groove on the last portion of the record.
3. If the groove is not traced correctly, cut off R31 ($3.3\text{k}\Omega$) on the Control P.C.Board and re-check the tracing. (Fig. 6)

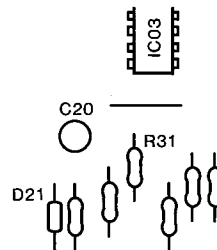

Fig. 6

TURNTABLE ADJUSTMENTS (Continued)

Photointerrupter Position Adjustment for Arm Feed

1. Turn on the power switch of the unit.
2. Place a record with less eccentricity on the turntable and play it.
3. After the record has rotated three or four times, raise the arm by pressing the CUEING button.
4. Turn the arm feed adjustment screw with a screwdriver through the hole on the right side of the cabinet, so that the arm rises straight up. (Fig. 7)

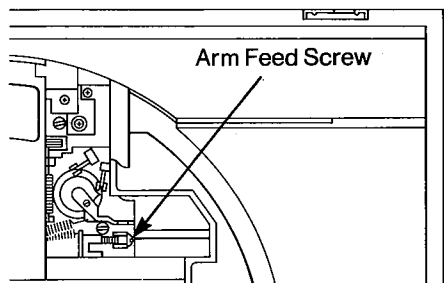

Fig. 7

End Return Sensitivity Adjustment

1. Turn on the power switch of the unit.
2. Connect the oscilloscope to TP . (Fig. 9)
3. Play a record and adjust VR01 (100 K-B), so that the peak value of the DC element becomes 2.6 ~ 2.8V. (Fig. 10)
4. Confirm that the END Return is smoothly exercised.

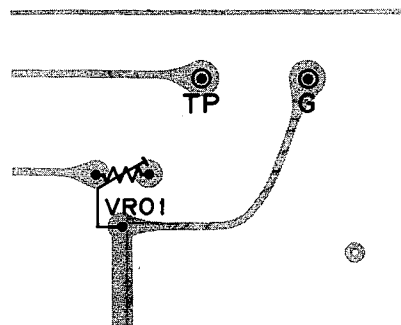

Fig. 9

Lead-in Position Adjustment

1. Turn on the power switch of the unit.
2. Place a record on the turntable and perform the lead-in operation.
3. Adjust the lead-in position adjustment cam, so that the record is led into the correct position.

Note: If the cam is turned clockwise, the tonearm moves inward. It moves outward if the cam is turned counter-clockwise. (Fig. 8)

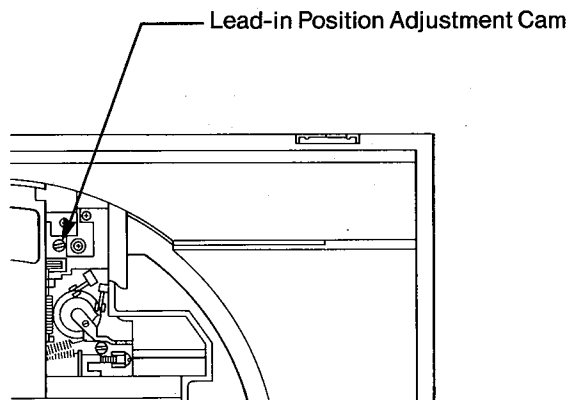

Fig. 8

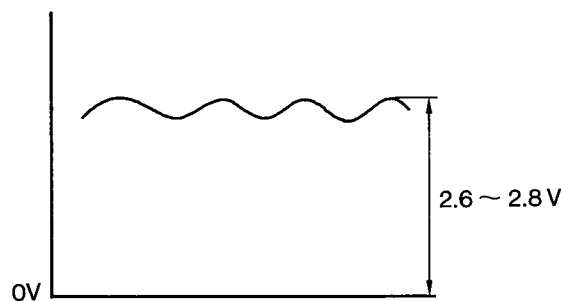
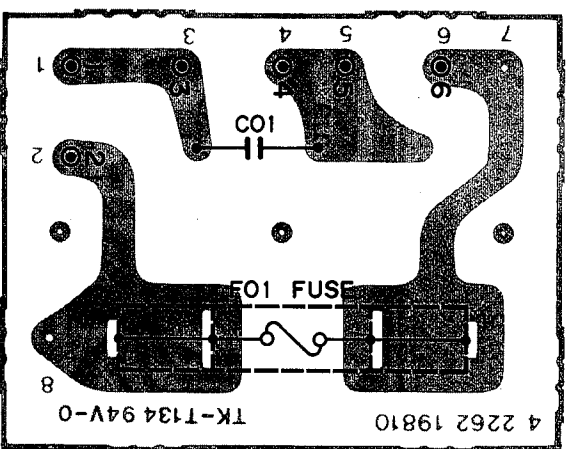
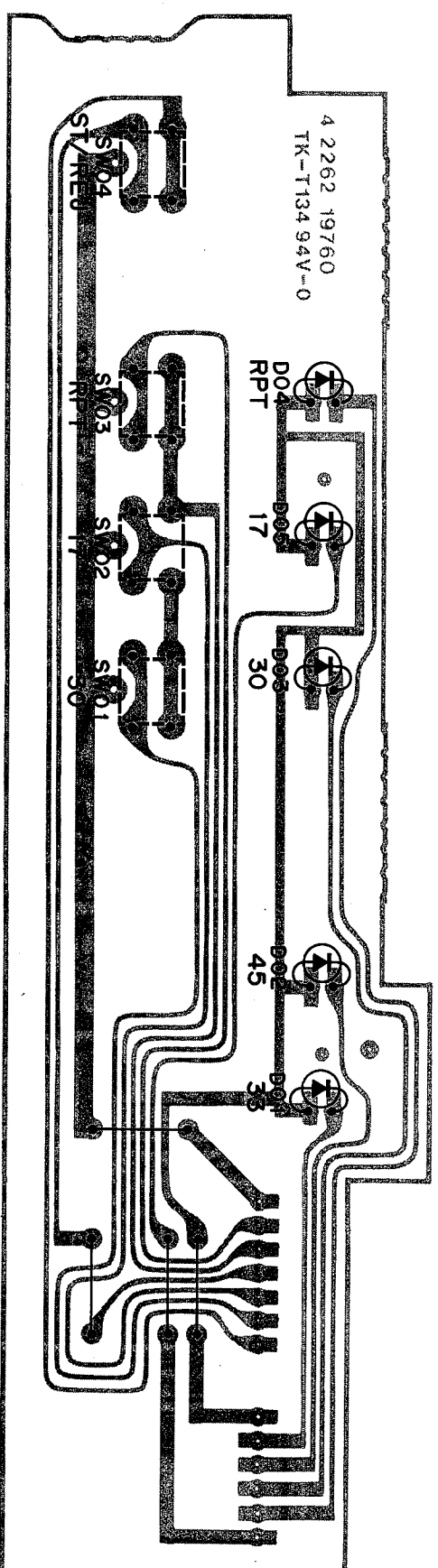

Fig. 10

FUSE P.C. BOARD
(BOTTOM VIEW)



SWITCH LED P.C. BOARD
(BOTTOM VIEW)



SWITCH P.C. BOARD
(BOTTOM VIEW)

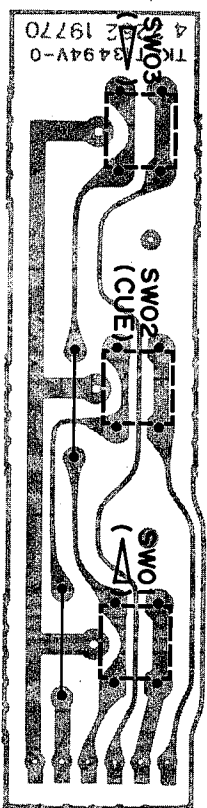

PCR P.C. BOARD
(BOTTOM VIEW)

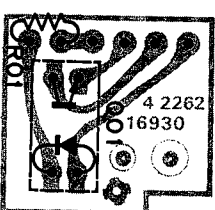

SPEED SWITCH P.C. BOARD
(BOTTOM VIEW)

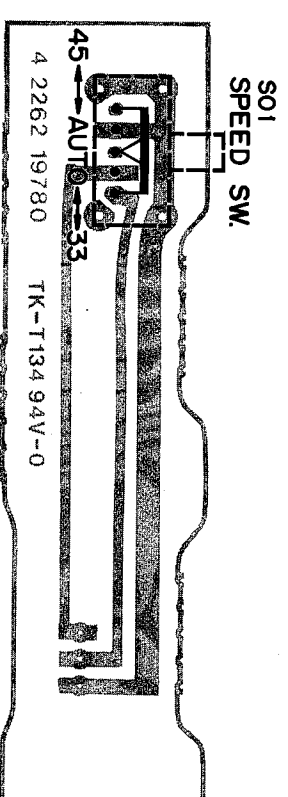

TERMINAL P.C. BOARD
(BOTTOM VIEW)

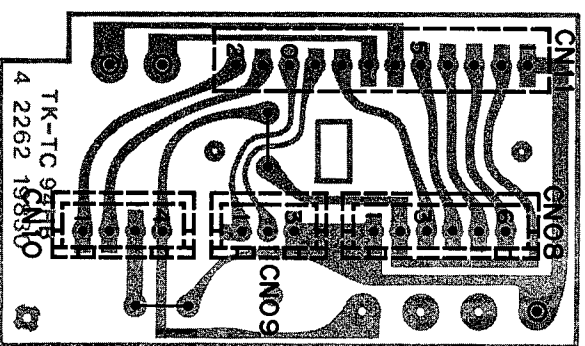

PTR P.C. BOARD
(BOTTOM VIEW)

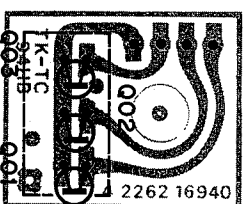

LED P.C. BOARD
(BOTTOM VIEW)

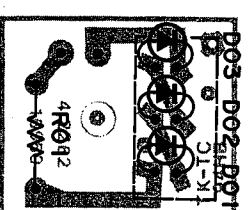

VOLUME P.C. BOARD
(BOTTOM VIEW)

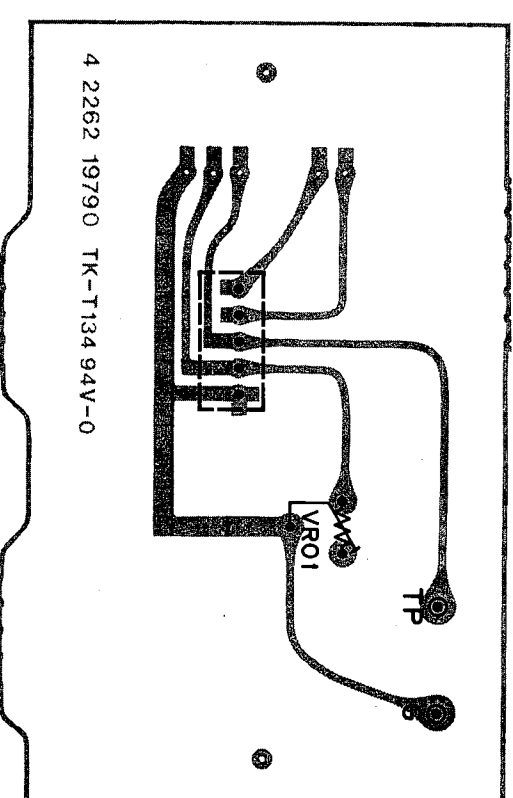

CONTROL P.C. BOARD (BOTTOM VIEW)

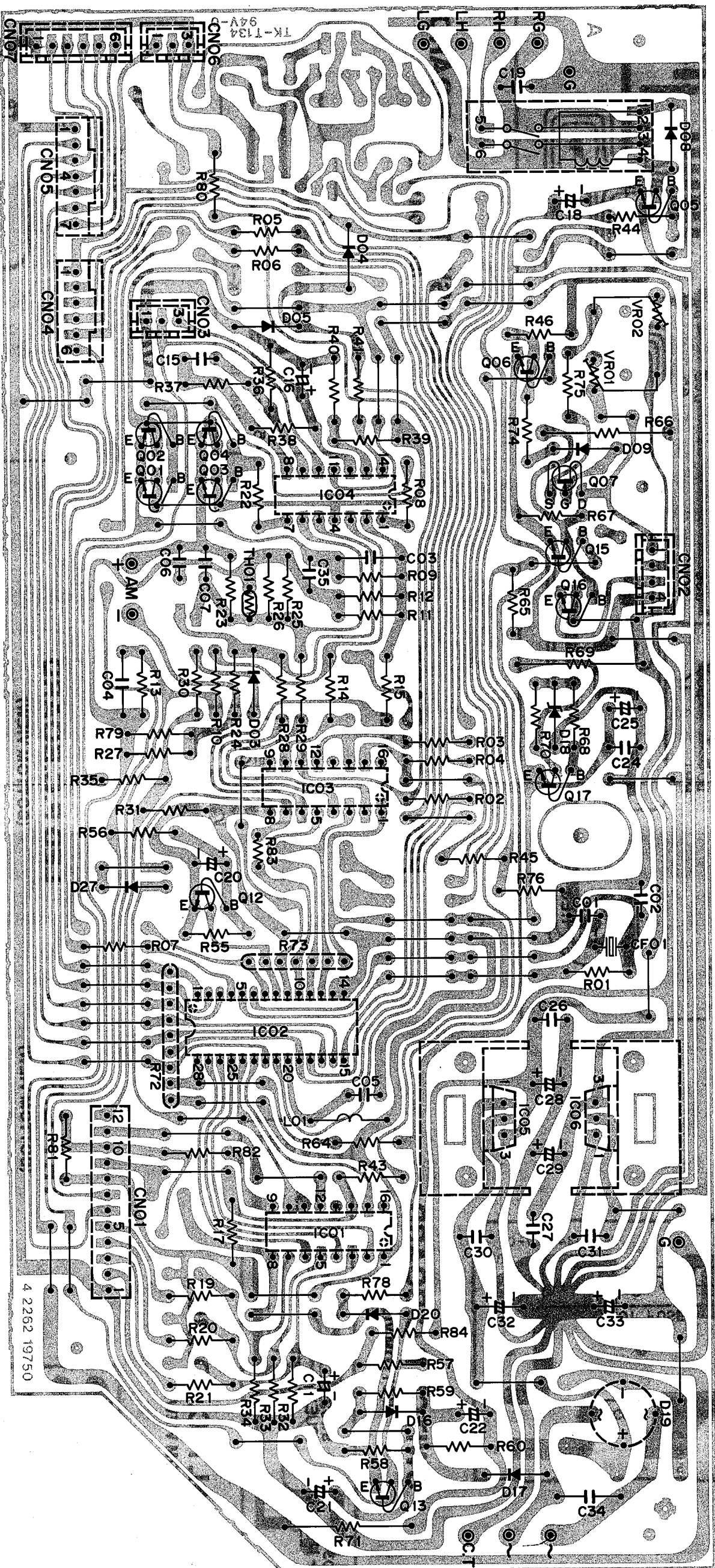

IC PIN NUMBERS DC VOLTAGES

SYMBOL No.	DEVICE	1	2	3	4	5	6	7	8	9	10	11	12	13	14	15	16	17	18	19	20	
IC01	MSM4049S	5.3V	0V	4.7V	5.3V	0V	5.3V	0V	0V	5.3V	5.3V	0V	0V	-	3.7V	0V	-					
IC03	MSM4049S	5.3V	0V	5.3V	0V	5.3V	0V	5.2V	0V	5.3V	0V	5.2V	0.6V	-	0.6V	5.2V	-					
IC04	LA6324	0.6V	0V	0V	12.4V	0V	0V	-0.9V	0V	0V	-12.1V	0V	3.4V	-11.4V								
IC05	NJM7812	19.0V	0V	12.4V																		
IC06	NJM7912	0V	-20.0V	-12.1V																		
IC02	LM6416E	5.3V	5.3V	5.3V	4.0V	2.5V	2.1V	5.3V	5.3V	5.3V	5.3V	5.3V	5.3V	0V	3.4V	5.0V	4.9V	4.9V	5.3V	5.2V		
		21	22	23	24	25	26	27	28													
		-6.0V	5.2V	0V	5.3V	0V	5.3V	5.3V	3.8V													

TRANSISTOR DC VOLTAGES

SYMBOL No.	DEVICE	B	C	E	SYMBOL No.	DEVICE	B	C	E
001	2SD863	0.6V	12.4V	0V	013	2SC536	0.7V	0V	0V
002	2SB764	0.6V	-12.1V	0V	015	2SC536	0.7V	0.3V	0V
003	2SD863	-0.8V	12.4V	-0.2V	016	2SD863	0.3V	12.4V	0V
004	2SB764	-0.8V	-12.1V	-0.2V	017	2SD863	5.9V	9.6V	5.3V
005	2SC536	0.7V	0.7V	0V					
006	2SC536	0.7V	0V	0V					
012	2SC536	0V	5.3V	0V	007	2SK304	-0.6V	0V	0V

P.C.BOARD PARTS LIST

Ref. No.	Part No.	Description	Q'ty	Ref. No.	Part No.	Description	Q'ty	
CONTROL P.C.B. ASSY								
PCB1	141 0 1939 05390	Control P.C.B. Assy	1	C25	CD4 7 6100 0001V	Electrolytic	47μF 10V	
	103 3 1903 00611	Screw, Brazier Hd. Tapping-2, +M3.0x6	2	C26	CM1 0 4500 J00TV	Mylar	0.1μF 50V ±5%	
	111 2 6220 11100	Wire Wrap Terminal	11	C27	CM1 0 4500 J00TV	Mylar	0.1μF 50V ±5%	
	131 2 6201 35500	Plate Heat Sink	2	C28	CD1 0 7160 0001V	Electrolytic	100μF 16V	
	141 2 4729 05000	Staple 5	1	C29	CD1 0 7160 0001V	Electrolytic	100μF 16V	
CN1	4 2369 71901	Connector 12P Top	1	C30	CC1 0 3500 ZG00C	Ceramic	0.01μF 50V +80,-20%	
CN2	4 2369 73140	Connector 4P	1	C31	CC1 0 3500 ZG00C	Ceramic	0.01μF 50V +80,-20%	
CN3	4 2369 73130	Connector 3P	1	C32	4 2239 71360	Electrolytic	1000μF 25V	
CN4	4 2362 00370	6P Plug	1	C33	CD4 7 7250 0000V	Electrolytic	470μF 25V	
CN5	4 2362 00400	Plug 7P	1	C34	CC1 0 3501 YEY0C	Ceramic	0.01μF 500V +100,-0%	
CN6	4 2369 73970	Plug 3P	1	C35	CM1 0 3500 K00SV	Mylar	0.01μF 50V ±10%	
CN7	4 2369 73160	Connector 6P	1	R1	RD1 0 5251 JM000	Carbon	1MΩ 1/4W ±5%	
L1	4 2532 00540	Choke Coil 47μH	1	R2	RD1 0 3251 JM000	Carbon	10kΩ 1/4W ±5%	
VR1	4 2222 01010	Semi-fixed (B-50kΩ)	1	R3	RD3 3 1251 JM000	Carbon	330Ω 1/4W ±5%	
VR2	4 2222 01040	Semi Fixed (B-20kΩ)	1	R4	RD3 3 1251 JM000	Carbon	330Ω 1/4W ±5%	
CF1	4 2252 00090	CSB400P	1	R5	RD3 3 1251 JM000	Carbon	330Ω 1/4W ±5%	
RE1	4 2329 70310	Reed Relay	1	R6	RD1 5 1251 JM000	Carbon	150Ω 1/4W ±5%	
IC1	4 2069 72530	IC, MSM 4049 RS	1	R7	RD3 3 1251 JM000	Carbon	330Ω 1/4W ±5%	
IC2	208 5 3806 41635	IC, LM6416E-352	1	R8	RD2 2 2251 JM000	Carbon	2.2kΩ 1/4W ±5%	
IC3	4 2069 72530	IC, MSM 4049 RS	1	R9	RD1 0 2251 JM000	Carbon	1kΩ 1/4W ±5%	
IC4	206 5 1296 32410	IC, LA 6324	1	R10	RD4 7 1251 JM000	Carbon	470Ω 1/4W ±5%	
IC5	4 2069 72560	IC, NJM 7812	1	R11	RD4 7 1251 JM000	Carbon	470Ω 1/4W ±5%	
IC6	4 2069 72570	IC, NJM 7912	1	R12	RD4 7 1251 JM000	Carbon	470Ω 1/4W ±5%	
Q1	203 5 7340 86350	Transistor, 2SD 863	1	R13	RD3 9 A251 JS000	Carbon	3.9Ω 1/4W ±5%	
Q2	203 5 7350 76450	Transistor, 2SB 764	1	R14	RD2 7 2251 JM000	Carbon	2.7kΩ 1/4W ±5%	
Q3	203 5 7340 86350	Transistor, 2SD 863	1	R15	RD8 2 1251 JM000	Carbon	820Ω 1/4W ±5%	
Q4	203 5 7350 76450	Transistor, 2SB 764	1	R17	RD1 0 3251 JM000	Carbon	10kΩ 1/4W ±5%	
Q5	203 5 5000 53670	Transistor, 2SC 536	1	R19	RD1 0 3251 JM000	Carbon	10kΩ 1/4W ±5%	
Q6	203 5 5000 53650	Transistor, 2SC 536	1	R20	RD1 0 3251 JM000	Carbon	10kΩ 1/4W ±5%	
Q7	203 5 4370 30460	FET, 2SK 304	1	R21	RD1 0 3251 JM000	Carbon	10kΩ 1/4W ±5%	
Q12	203 5 5000 53650	Transistor, 2SC 536	1	R22	RD2 2 2251 JM000	Carbon	2.2kΩ 1/4W ±5%	
Q13	203 5 5000 53650	Transistor, 2SC 536	1	R23	RD1 0 2251 JM000	Carbon	1kΩ 1/4W ±5%	
Q15	203 5 5000 53670	Transistor, 2SC 536	1	R24	RD4 7 1251 JM000	Carbon	470Ω 1/4W ±5%	
Q16	203 5 7340 86350	Transistor, 2SD 863	1	R25	RD4 7 1251 JM000	Carbon	470Ω 1/4W ±5%	
Q17	203 5 7340 86350	Transistor, 2SD 863	1	R26	RD4 7 1251 JM000	Carbon	470Ω 1/4W ±5%	
D3	202 5 2810 44210	Diode, DS 442	1	R27	RD4 7 A251 JS000	Carbon	4.7Ω 1/4W ±5%	
D4	202 5 2810 44210	Diode, DS 442	1	R28	RD3 9 2251 JM000	Carbon	3.9kΩ 1/4W ±5%	
D5	202 5 2810 44210	Diode, DS 442	1	R29	RD1 2 2251 JM000	Carbon	1.2kΩ 1/4W ±5%	
D8	202 5 2810 44210	Diode, DS 442	1	R30	RD3 3 2251 JM000	Carbon	3.3kΩ 1/4W ±5%	
D9	202 5 2810 44210	Diode, DS 442	1	R31	RD3 3 2251 JM000	Carbon	3.3kΩ 1/4W ±5%	
D16	202 5 2810 44210	Diode, DS 442	1	R32	RD1 0 4251 JM000	Carbon	100kΩ 1/4W ±5%	
D17	202 5 2470 13540	Diode, DS 135	1	R33	RD1 0 4251 JM000	Carbon	100kΩ 1/4W ±5%	
D18	202 5 3210 05613	Zener Diode, GZA5.6Z	1	R34	RD1 0 4251 JM000	Carbon	100kΩ 1/4W ±5%	
D19	DGG - W02 - - - - -	Diode, W 02	1	R35	RD4 7 3251 JM000	Carbon	47kΩ 1/4W ±5%	
D20	202 5 2810 44210	Diode, DS 442	1	R36	RD2 7 3251 JM000	Carbon	27kΩ 1/4W ±5%	
D22	202 5 2810 44210	Diode, DS 442	1	R37	RD1 2 4251 JM000	Carbon	120kΩ 1/4W ±5%	
TH1	204 5 9000 05000	Thermistor, SDT 500	1	R38	RD4 7 3251 JM000	Carbon	47kΩ 1/4W ±5%	
C1	CP2 2 1101 J003V	Polypropylen	220pF 100V ±5%	1	R39	RD2 2 3251 JM000	Carbon	22kΩ 1/4W ±5%
C2	CP2 2 1101 J003V	Polypropylen	220pF 100V ±5%	1	R40	RD8 2 2251 JM000	Carbon	8.2kΩ 1/4W ±5%
C3	CC3 3 1250 KE00R	Ceramic	330pF 25V ±10%	1	R41	RD1 0 3251 JM000	Carbon	10kΩ 1/4W ±5%
C4	CH1 0 3250 NF00R	Boundary	0.01μF 25V ±30%	1	R43	RD1 0 3251 JM000	Carbon	10kΩ 1/4W ±5%
C5	CM1 0 4500 J00TV	Mylar	0.1μF 50V ±5%	1	R44	RD1 0 3251 JM000	Carbon	10kΩ 1/4W ±5%
C6	CM1 0 3500 K00SV	Mylar	0.01μF 50V ±10%	1	R45	RD2 2 3251 JM000	Carbon	22kΩ 1/4W ±5%
C7	CC3 3 1500 KD00C	Ceramic	330pF 50V ±10%	1	R46	RD1 0 3251 JM000	Carbon	10kΩ 1/4W ±5%
C11	CD2 2 5500 0001V	Electrolytic	2.2μF 50V	1	R55	RD1 0 3251 JM000	Carbon	10kΩ 1/4W ±5%
C15	CM1 0 3500 K00SV	Mylar	0.01μF 50V ±10%	1	R56	RD4 7 3251 JM000	Carbon	47kΩ 1/4W ±5%
C16	CD4 7 5250 0001V	Electrolytic	4.7μF 25V	1	R57	RD1 0 3251 JM000	Carbon	10kΩ 1/4W ±5%
C18	CD1 0 6160 0001V	Electrolytic	10μF 16V	1	R58	RD1 0 3251 JM000	Carbon	10kΩ 1/4W ±5%
C19	CC1 0 3500 ZG00C	Ceramic	0.01μF 50V +80,-20%	1	R59	RD6 8 3251 JM000	Carbon	68kΩ 1/4W ±5%
C20	CD1 0 4500 0001V	Electrolytic	0.1μF 50V	1	R60	RD6 8 2251 JM000	Carbon	6.8kΩ 1/4W ±5%
C21	CD4 7 6250 0001V	Electrolytic	47μF 25V	1	R64	RD2 2 3251 JM000	Carbon	22kΩ 1/4W ±5%
C22	CD4 7 5500 0001V	Electrolytic	4.7μF 50V	1	R65	RD2 2 3251 JM000	Carbon	22kΩ 1/4W ±5%
C24	CM1 0 4500 J00TV	Mylar	0.1μF 50V ±5%	1	R66	RH4 7 1102 JZ000	Metal	470Ω 1W ±5%
				1	R67	RD1 0 3251 JM000	Carbon	10kΩ 1/4W ±5%

P.C.BOARD PARTS LIST (Continued)

Ref. No.	Part No.	Description	Q'ty
R68	RD2 2 1251 JM000	Carbon 220Ω 1/4W ±5%	1
R69	RH3 9 0102 JZ000	Metal 39Ω 1W ±5%	1
R70	RD6 8 1251 JM000	Carbon 680Ω 1/4W ±5%	1
R71	RH4 7 1102 JZ000	Metal 470Ω 1W ±5%	1
R72	4 2219 70460	Resistor 10k x 8 J	1
R73	4 2219 70450	Resistor 10k x 6 J	1
R74	RD4 7 3251 JM000	Carbon 47kΩ 1/4W ±5%	1
R75	RD1 0 2251 JM000	Carbon 1kΩ 1/4W ±5%	1
R76	RD2 2 3251 JM000	Carbon 22kΩ 1/4W ±5%	1
R78	RD2 2 3251 JM000	Carbon 22kΩ 1/4W ±5%	1
R79	RD1 0 1251 JM000	Carbon 100Ω 1/4W ±5%	1
R80	RD1 0 2251 JM000	Carbon 1kΩ 1/4W ±5%	1
R81	RD1 0 3251 JM000	Carbon 10kΩ 1/4W ±5%	1
R82	RD1 0 3251 JM000	Carbon 10kΩ 1/4W ±5%	1
R83	RD1 0 3161 JH000	Carbon 10kΩ 1/6W ±5%	1
R84	RD1 0 0251 JS000	Carbon 10Ω 1/4W ±5%	1
PCR P.C.B. ASSY			
PCB2	141 0 1939 02710	PCR P.C.B. Assy	1
CN10	4 2359 76742	Connector 4P Assy	1
Q1	4 2039 71430	Photo Interrupter	1
R1	RD5 6 1251 JN000	Carbon 560Ω 1/4W ±5%	1
PTR P.C.B. ASSY			
PCB3	141 0 1939 02721	PTR P.C.B. Assy	1
	141 2 3529 38900	LED Spacer	1
CN8	4 2359 76606	Connector 6P Assy	1
Q1	4 2039 71500	Photo TR SPS-103-01	1
Q2	4 2039 71500	Photo TR SPS-103-01	1
Q3	4 2039 71500	Photo TR SPS-103-01	1
LED P.C.B. ASSY			
PCB4	141 0 1939 02731	LED P.C.B. Assy	1
	141 2 3529 38900	LED Spacer	1
D1	4 2029 73160	Photo D. SLR-902A-01	1
D2	4 2029 73160	Photo D. SLR-902A-01	1
D3	4 2029 73160	Photo D. SLR-902A-01	1
R1	RD5 6 1251 JM000	Carbon 560Ω 1/4W ±5%	1
TERMINAL P.C.B. ASSY			
PCB5	141 0 1939 05470	Terminal P.C.B. Assy	1
	111 2 6220 11100	Wire Wrap Terminal	3
	141 2 4729 05000	Staple 5	2
CN8	4 2369 73160	Connector 6P	1
CN9	4 2369 73130	Connector 3P	1
CN10	4 2369 73140	Connector 4P	1
CN11	4 2369 71901	Connector 12P Top	1
SWITCH LED P.C.B. ASSY			
PCB6	141 0 1939 05400	Switch LED P.C.B. Assy	1
	141 2 3529 44500	Spacer	1
	131 0 4006 22293	Cord Assy	1
	131 0 4006 22291	Cord Assy	1
SW1	4 2312 05801	Key Board SW (30)	1
SW2	4 2312 05801	Key Board SW (17)	1
SW3	4 2312 05801	Key Board SW (Repeat)	1
SW4	4 2312 05801	Key Board SW (ST/REJ)	1
D1	DYY - SLR- 54VT-	LED, SLR 54 VT 3 (33rpm)	1
D2	DYY - SLR- 54VT-	LED, SLR 54 VT 3 (45rpm)	1

Ref. No.	Part No.	Description	Q'ty
D3	DYY - SLR- 54VT-	LED, SLR 54 VT 3 (30cm)	1
D4	DYY - SLR- 54PT-	LED, SLR 54 PT 3 (Repeat)	1
D5	DYY - SLR- 54VT-	LED, SLR 54 VT 3 (17cm)	1
SWITCH P.C.B. ASSY			
PCB7	141 0 1939 05410	Switch P.C.B. Assy	1
CN7	4 2359 77620	Connector 6P Assy	1
SW1	4 2312 05801	Key Board Switch (<)	1
SW2	4 2312 05801	Key Board Switch (CUE)	1
SW3	4 2312 05801	Key Board Switch (>)	1
SPEED SWITCH P.C.B. ASSY			
PCB8	141 0 1939 05420	Speed Switch P.C.B. Assy	1
CN6	4 2359 77622	Connector 3P Assy	1
S1	4 2319 76670	Slide Switch (Speed)	1
VOLUME P.C.B. ASSY			
PCB9	141 0 1939 05430	Volume P.C.B. Assy	1
	4 2362 00100	Plug 5P	1
	111 2 6220 11100	Wire Wrap Terminal	2
CN3	4 2359 77621	Connector 3P Assy	1
VR1	4 2222 02680	Semi Fixed (B-100kΩ)	1
FUSE P.C.B. ASSY			
PCB10	141 0 1939 05450	Fuse P.C.B. Assy	1
	△ 4 2359 23000	Fuse Holder	2
	4 2372 00830	EC Terminal 1P	2
	111 2 6220 11100	Wire Wrap Terminal	4
	131 2 6114 01500	Cover Safety	1
F1	△ 4 2342 00130	Fuse (250mA)	1
C1 △	CK2 2 3631 M000V	Mylar 0.022μF 630V	1

NOTES:

1. Parts order must contain Model Number, Part Number and Description.
2. Ordering quantity of screws and resistors must be multiple of 10 pcs.

PRODUCT SAFETY NOTICE

Each precaution in this manual should be followed during servicing. Components identified with the IEC symbol Δ in the parts list and the schematic diagram designate components in which safety can be of special significance. When replacing a component identified with Δ , use only the replacement parts designated, or parts with the same ratings of resistance, wattage or voltage that are designated in the parts list in this manual. Leakage-current or resistance measurements must be made to determine that exposed parts are acceptably insulated from the supply circuit before returning the product to the customer.

IC SIGNAL FLOW & EQUIVALENT CIRCUIT

CONTROL IC LM 6416 E

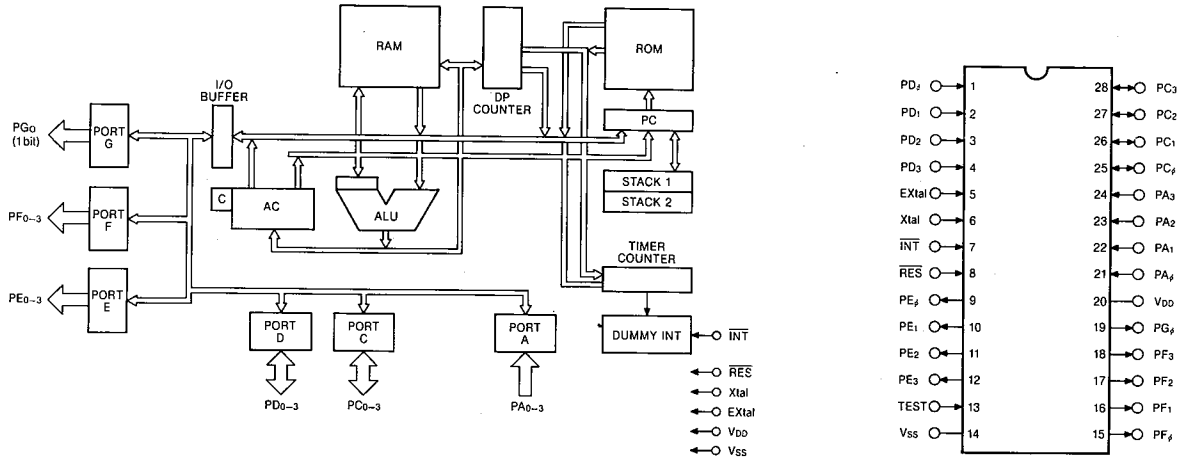

VOLTAGE REGULATOR IC NJM 7812

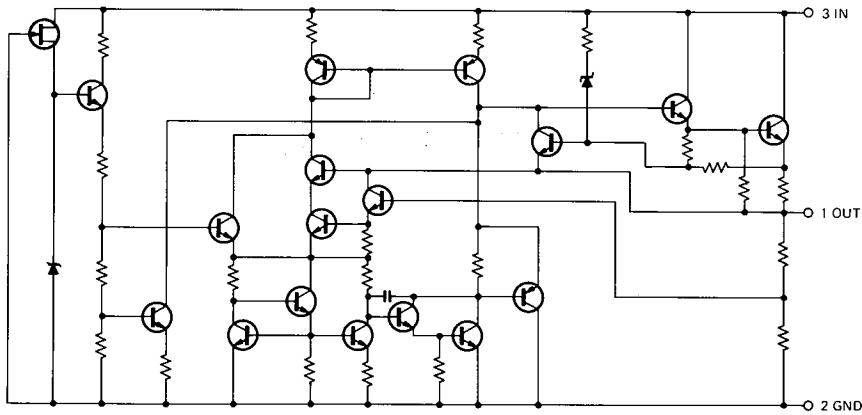

VOLTAGE REGULATOR IC NJM 7912

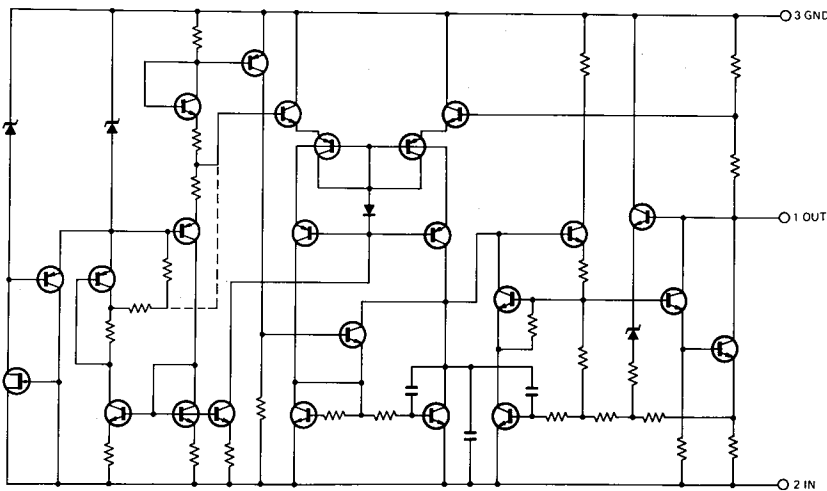

SEMICONDUCTOR LEAD IDENTIFICATION

INTEGRATED CIRCUITS

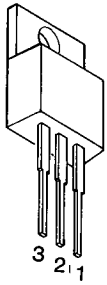

- NJM 7812
- NJM 7912

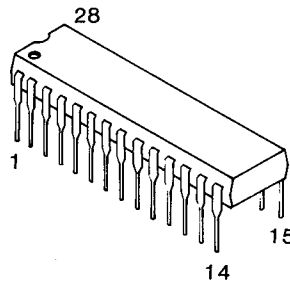

- LM 6416 E-352

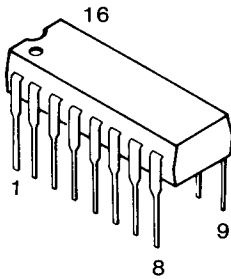

- MSM 4049 RS

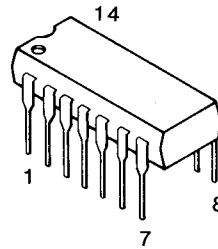

- LA 6324

BI-POLAR TRANSISTORS



- 2SC 536

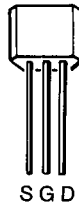

- 2SK 304



- 2SB 764
- 2SD 863

DIODES

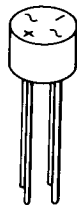

- W 02

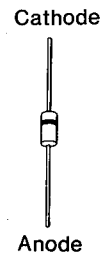

- DS 442
- GZA 5.6 Z

SCHEMATIC DIAGRAM

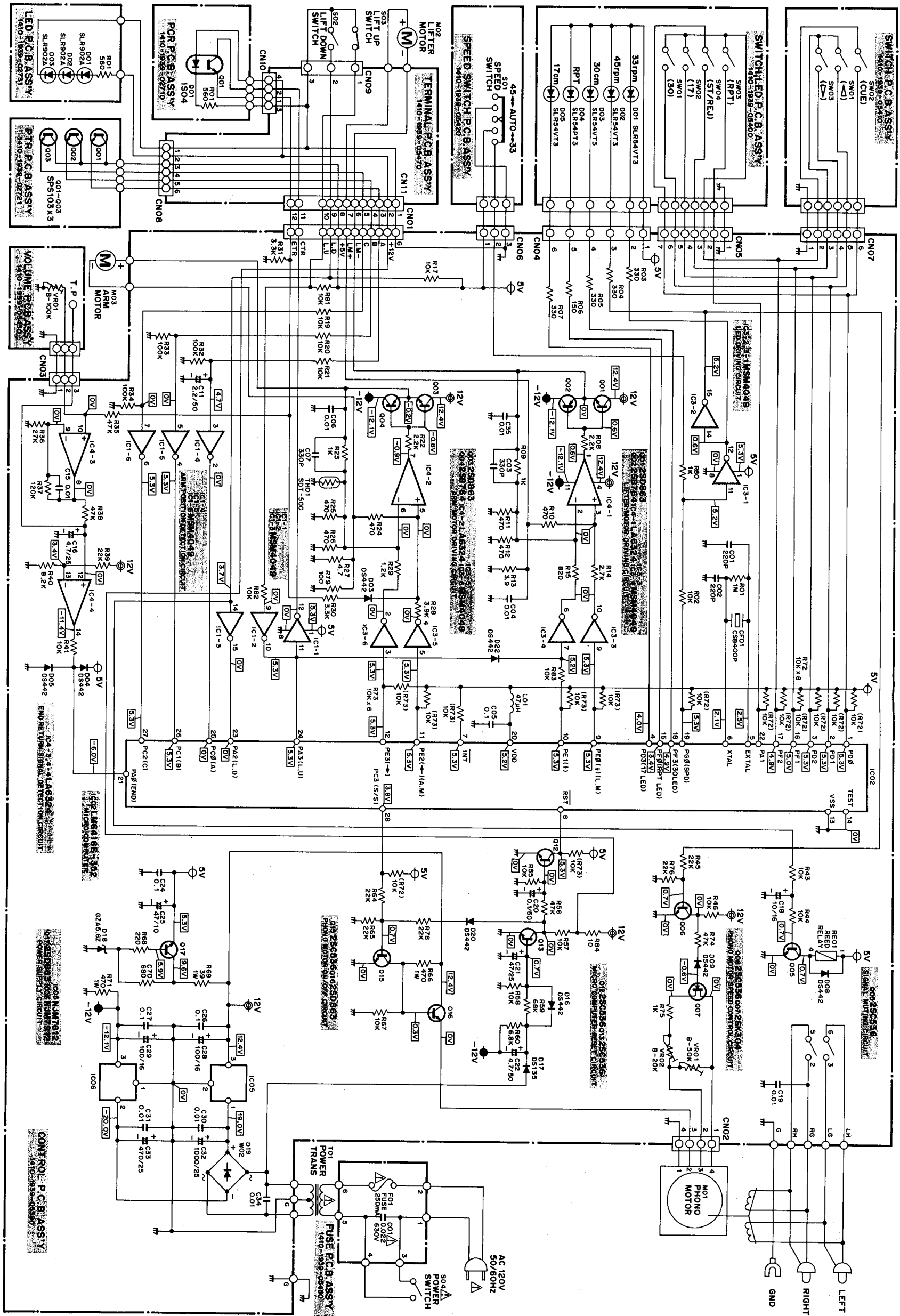

No.	Name	Position	No.	Name	Position	No.	Name	Position
S1	SPEED SWITCH	AUTO	SW1	SWITCH P.C.B. Assy	OFF	SW1	SWITCH LED P.C.B. Assy	OFF
S2	LIFT DOWN SWITCH	ON	SW2	() Switch	OFF	SW2	(30) Switch	OFF
S3	LIFT UP SWITCH	ON	SW3	() Switch	OFF	SW3	REPEAT SWITCH	OFF
S4	POWER SWITCH	OFF	SW4	() Switch	OFF	SW4	START/REJECT SWITCH	OFF

PRODUCT SAFETY NOTICE

Each precaution in this manual should be followed during servicing. Components identified with the IFC symbol (A) in the parts list and the schematic diagram designate components in which safety can be of special significance. When replacing a component identified with A, use only the replacement parts designated, or parts with the same ratings of resistance, wattage or voltage that are designated in the parts list in this manual. Leakage current or resistance measurements must be made to determine that exposed parts are acceptably insulated from the supply circuit before returning the product to the customer.

NOTES:

1. All resistor values are indicated in "ohm" ($K=10^3$, $M=10^6$).
2. All capacitor values are indicated in " μF " ($P=10^{-9}$).
3. All voltages indicated on the schematics are measured under the following conditions:
 - a. Use a V.T.V.M.
4. This is a basic schematic diagram.

Because Fisher products are subject to continuous improvement, Fisher Corporation reserves the right to make any changes or modifications without notice.

POINT TO POINT WIRING DIAGRAM

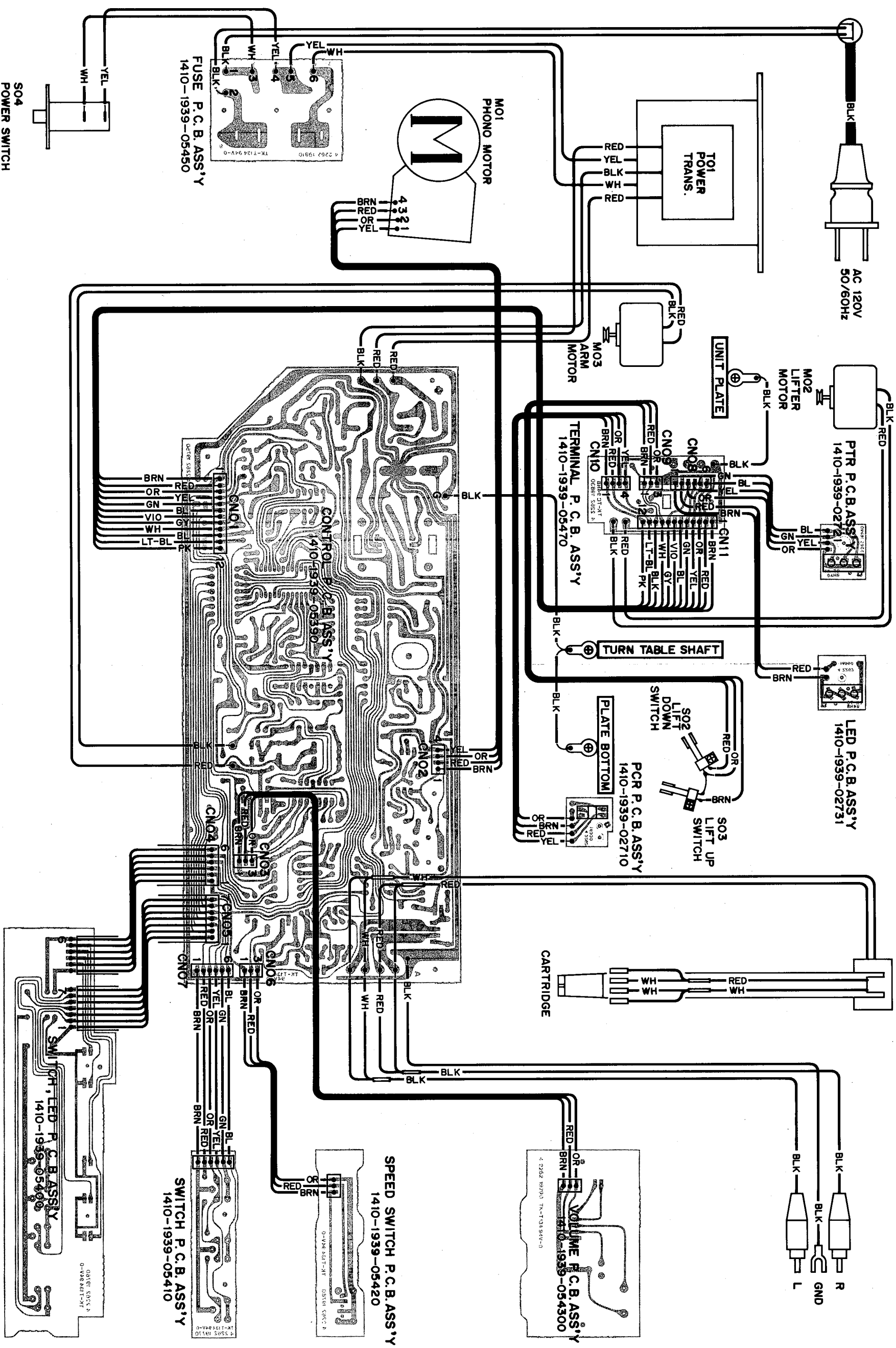

CAUTION OF USAGE FOR MOTOR

As the motors mounted on the MT-730 are used manufactured FUJIYA and MATSUSHITA, the resistance varies with each motor as follows:

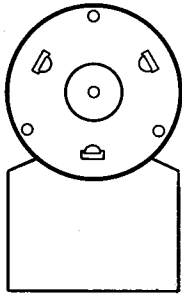

FUJIYA MOTOR

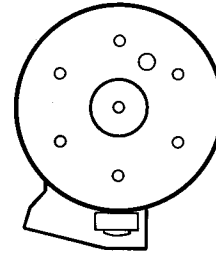

MATSUSHITA MOTOR

- 1340 5011 02803 Motor Assy
- 4 5272 00130 Motor
- 1342 6401 00130 Pulley

- 4 5272 00080 Motor
- 1342 6401 14500 Pulley

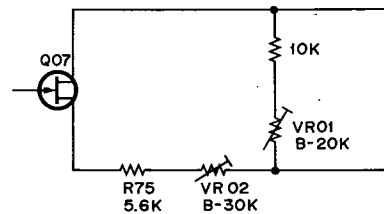
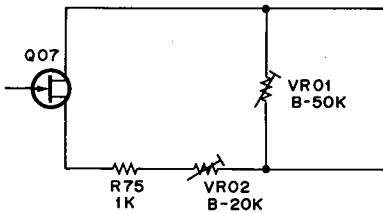

Ref. No.	FUJIYA MOTOR			MATSUSHITA MOTOR		
R75	Carbon	1kΩ	1/4W	Carbon	5.6kΩ	1/4W
VR01	Semi Fixed	(B-50kΩ)		Semi Fixed	(B-20kΩ)	
VR02	Semi Fixed	(B-20kΩ)		Semi Fixed	(B-30kΩ)	
	Not Used			Carbon	10kΩ	1/6W

CAUTION OF USAGE FOR IC03

As the IC03 mounted on the MT-730 are used both MSM4049RS (4 2069 72530) and TC4049BP (ITT-TC4049BP), the resistance varies with each IC as follows:

Ref. No.	MSM4049RS (4 2069 72530)			TC4049BP (ITT-TC4049BP)		
R14	Carbon	2.7kΩ	1/4W	Carbon	3.3kΩ	1/4W
R15	Carbon	820Ω	1/4W	Carbon	560Ω	1/4W
R27	Carbon	4.7Ω	1/4W	Carbon	3.9Ω	1/4W
R29	Carbon	1.2kΩ	1/4W	Carbon	820Ω	1/4W
R30	Carbon	3.3kΩ	1/4W	Carbon	5.6kΩ	1/4W
R79	Carbon	100Ω	1/4W	Not Used		

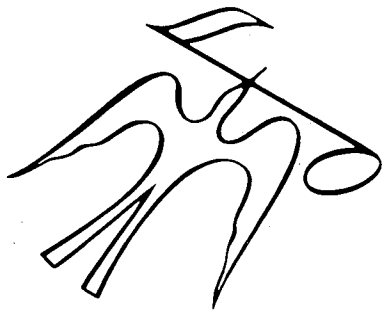

 **FISHER[®]**

Studio-Standard

FISHER CORPORATION, 21314 LASSEN STREET • CHATSWORTH • CALIFORNIA 91311

PRINTED IN JAPAN '84/July **WM-11789**