

SERVICE MANUAL



FISHER

MT-750

**Random Access
Linear Tracking Turntable
(EUROPE)**



134 080 50

CONTENTS

Arm Feed Cord Stringing	2
Specifications	3
Semiconductor Lead Identification	4
IC Signal Flow & Equivalent Circuit	5,6
Cabinet & Turntable Exploded View	7,8,9
Cabinet & Turntable Parts List	10,11
Functional Description	12,13,14
Adjustment Procedures	15,16,17
P.C.Board Parts List	18,19,20
Printed Circuit Board (Bottom View)	21,22,23,24,25,26
Schematic Diagram	27,28
Point to Point Wiring Diagram	29,30
Motor Assy Schematic Diagram	31
Motor Assy P.C.Board (Bottom View)	31

ARM FEED CORD STRINGING

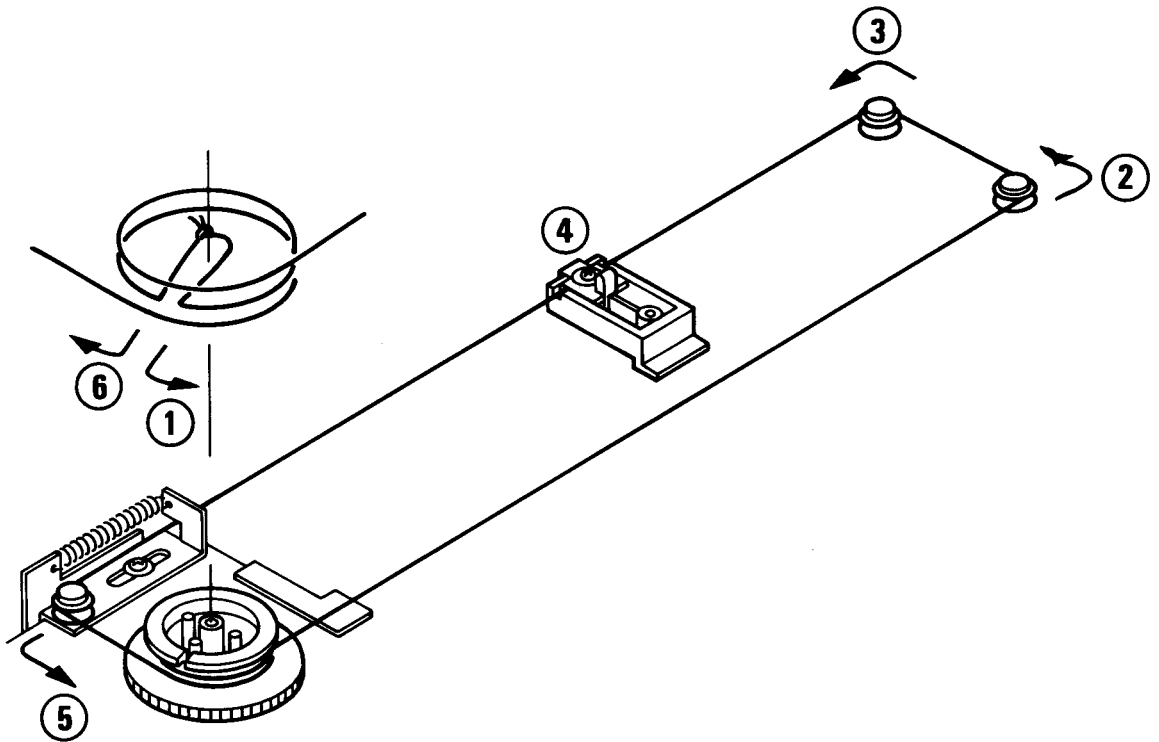

SPECIFICATIONS

TURNTABLE	MT-750
Motor	Quartz Locked FG Servo
Drive System	Direct
Wow and Flutter (WRMS)	0.035 %
Rumble (DIN 45539B)	-70 dB
Speed Variation	±1.5 %
Tracking Force	2 g
Platter Diameter	12-1/8"
Platter Weight	1.4 lbs.
Record Speed Selector	33-1/3 rpm/ 45 rpm
Auto Function	
Start	Yes
Repeat	Yes
Reject	Yes
Automatic Tonearm Return at End of Record	Yes
Manual Function	
Start	Yes
Stop	Yes
Tonearm Data	
Resonance	<18 Hz
Effective Length	130 mm
Shape	Straight
Bearing Type	
Horizontal Friction Sensitivity	Pivot 0.15 g
Vertical Friction Sensitivity	Pivot 0.2 g
Max. Tracking Error	±0.2°
Cueing	Motor Drive
GENERAL	
Power Requirements (50 Hz)	AC 110/220V
Power Consumption	15 W
Dimensions (W x H x D)	440 x 98 x 355 mm
Weight (approx.)	5 kg

Because its products are subject to continuous improvement, Fisher Corporation reserves the right to modify product designs and specifications without notice and without incurring any obligation.

SEMICONDUCTOR LEAD IDENTIFICATION

INTEGRATED CIRCUITS

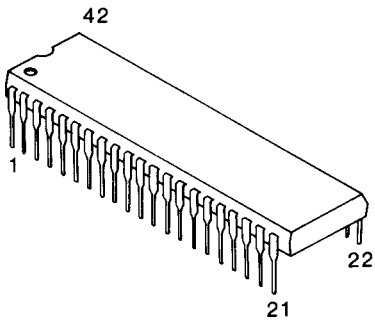

- LM 6402 A

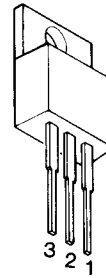

- NJM 7812
- NJM 7912
- L 78 M05

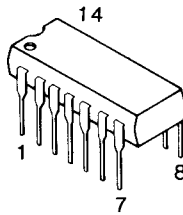

- MSM 4049 RS

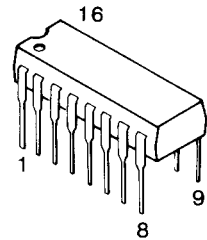

- LA 6324

TRANSISTORS



- 2SA 608
- 2SC 536



- 2SB 764
- 2SD 863

DIODES

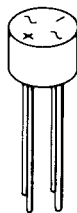

- W 02

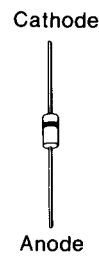

- DS 135 D
- DS 442
- GMA 01
- GZA 10 Y

IC SIGNAL FLOW & EQUIVALENT CIRCUIT

LM 6402 A

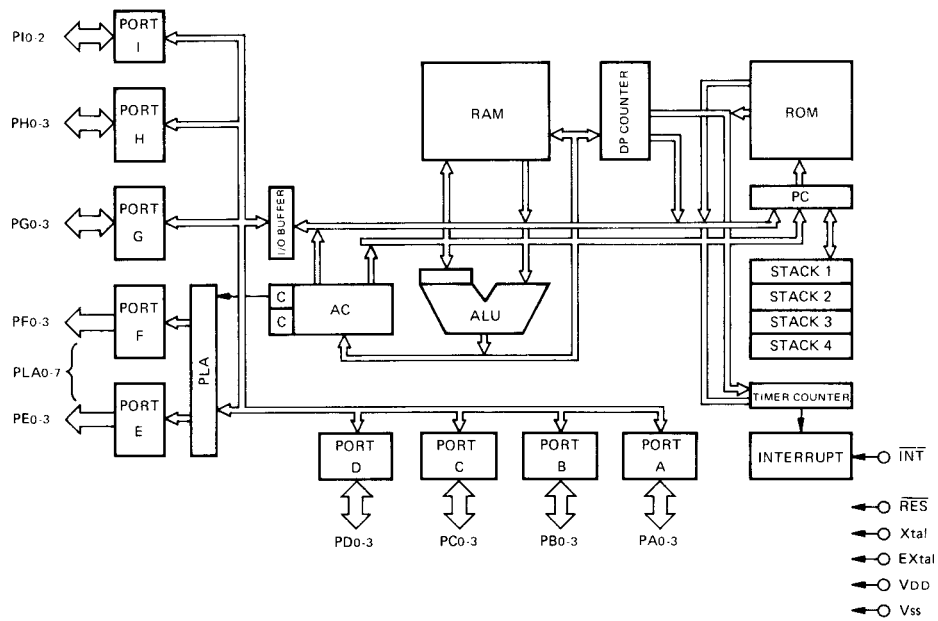

NJM 7812, L 78 M05

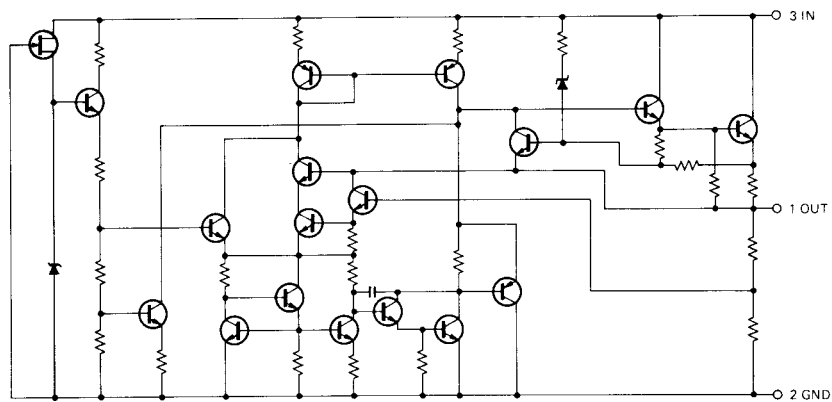

NJM 7912

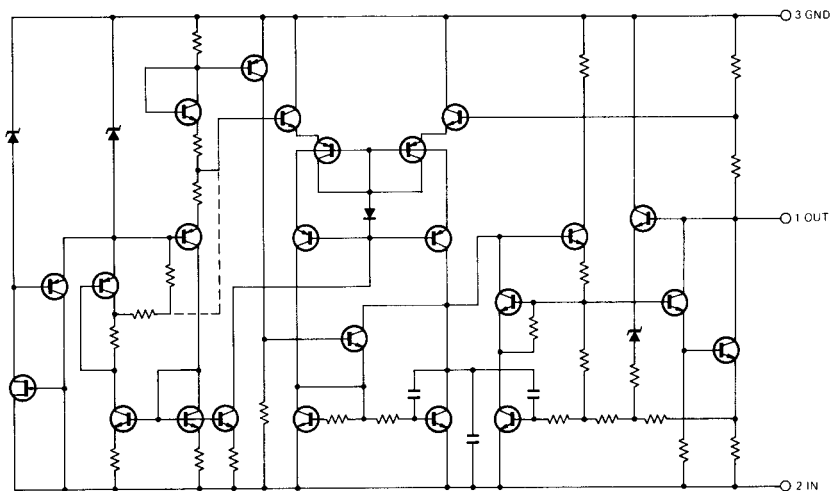

IC SIGNAL FLOW & EQUIVALENT CIRCUIT (Continued)

LA 6324

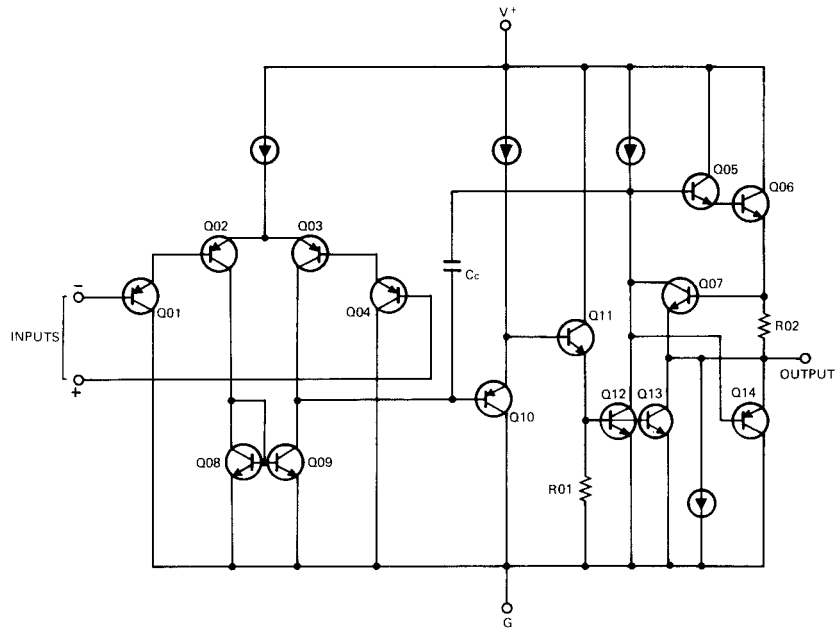

TOP VIEW

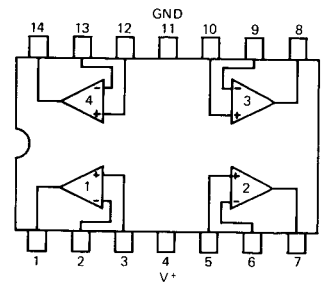

MSM 4049 RS

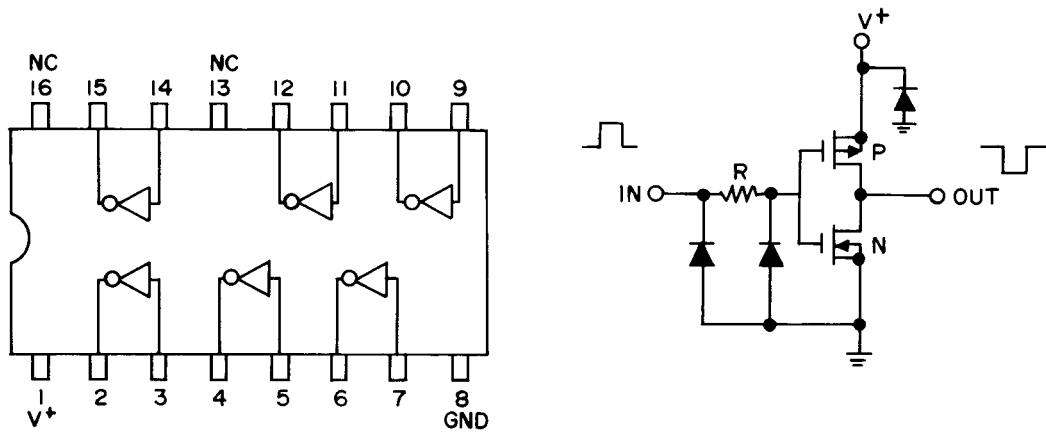

CABINET & TURNTABLE EXPLODED VIEW (3)

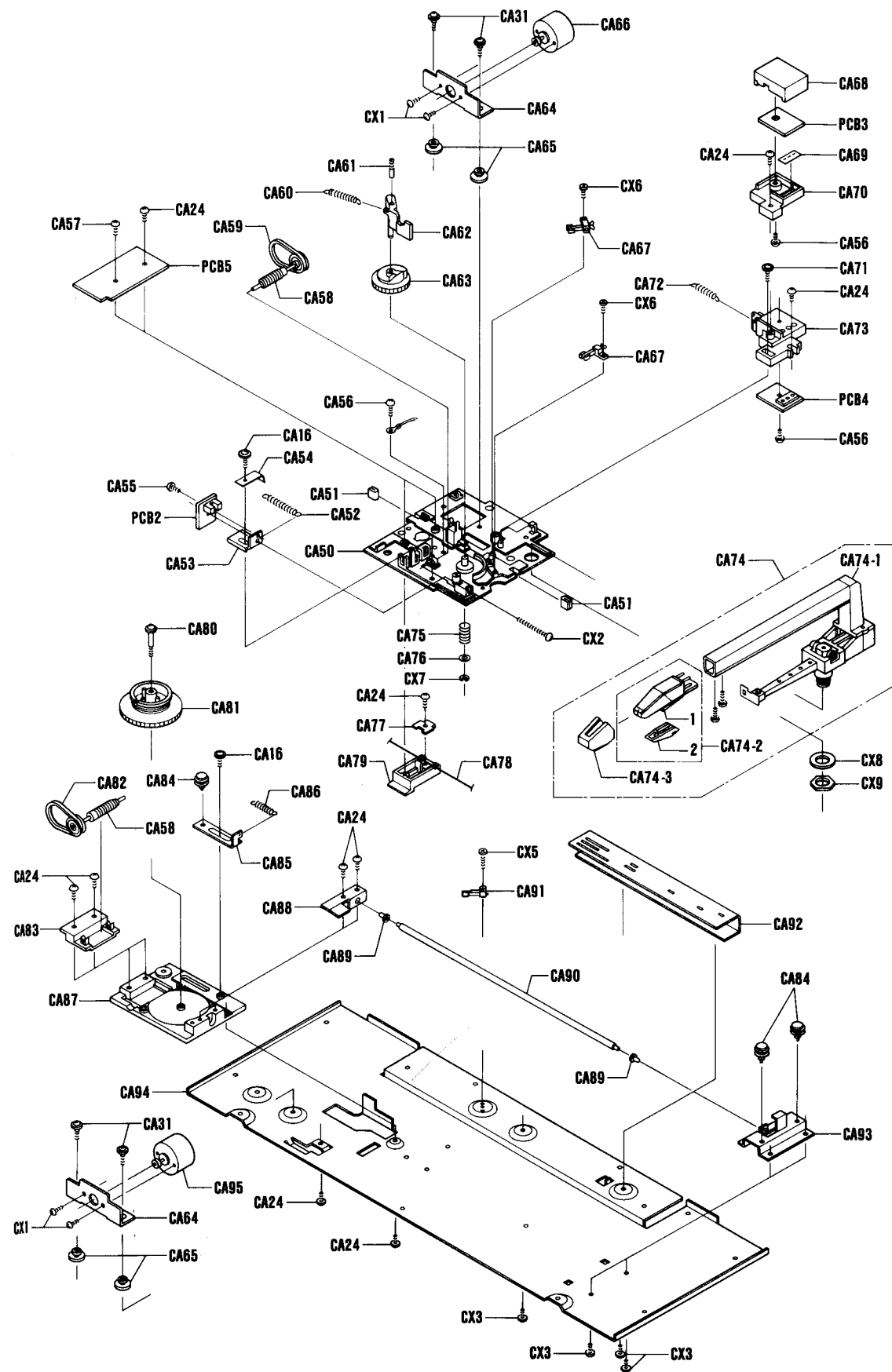

CABINET & TURNTABLE PARTS LIST

Ref. No.	Part No.	Description	Q'ty	Ref. No.	Part No.	Description	Q'ty
PACKAGE							
131	2 3901 10300	Staple SS19MM	8	CA27	141 2 3719 06200	Metal Mount Trans	1
131	6 2519 00201	Bag Polyethylene Ind	1	CA28	131 2 4201 25205	Screw	5
131	6 3069 17500	Patching Sheet	1	CA29	△ 4 2512 30420	Power Trans [T1]	1
131	6 4159 10106	Notes	3	CA30	131 2 3608 12405	Cramp Wire	1
131	6 4559 10900	Manufacturing No.	2	CA31	134 2 4201 13400	Screw	8
134	2 2104 12300	Screw Transit(+,-)	3	CA32	141 2 1149 39400	Cover	1
134	2 4208 15100	Spacer	3	CA33	131 2 4201 20801	Screw, +M2.6x8	2
141	2 4219 32700	Screw Transit	1	CA34	△ 4 2312 06051	Switch Push Power [S4]	1
141	6 1139 98402	Box Corrugate-exp	1	CA35	131 2 4201 20300	Screw TP	2
141	6 2519 19490	Bag Polyethylene-exp	1	CA36	131 2 4203 84507	Washer Plain, M4.5x10x0.5	1
141	6 3119 23401	Pad	1	CA37	131 2 1601 85202	Knob Power	1
141	6 3119 24900	Pad Front	1	CA38	131 2 3608 11000	Cramp Wire	1
141	6 3119 25000	Pad Rear	1	CA39	141 2 4419 21100	Cloth	2
141	6 3119 25100	Pad	1	CA40	134 2 5205 12000	Cushion	2
ACCESSORIES							
4	2369 74031	Plug Cord	1	CA41	131 2 1601 59501	Knob	1
131	2 3901 10400	Staple No.10	1	CA42	131 2 4201 24600	Screw	1
131	6 2719 10801	Bag Fan	1	CA43	141 2 1659 35700	Knob	1
131	6 4519 15700	Guarantee Cert	1	CA44	141 2 1259 07300	Plate Bottom	2
131	6 4559 10900	Manufacturing No	1	CA45	141 2 8559 06505	Spring Mounting	2
134	2 2901 11601	Adapter Ep	1	CA46	141 2 4459 31700	Cushion(Leg)	4
142	6 4119 32156	Explanatory Booklet	1	CA47	131 2 5203 23603	Felt	4
CABINET							
4	2359 75222	Connector 12P Assy [CN9]	1	CA48	141 2 8559 06506	Spring Mounting	1
4	2359 76794	Connector 3P Assy [CN13]	1	CA49	141 2 8559 06501	Spring Mounting	1
4	2359 77145	Connector 1P Assy	1	CA50	141 0 3129 01900	Unit Plate Assy	1
4	2359 77631	Connector 1P Assy	1	CA51	141 2 4459 33800	Cushion	2
131	2 1310 34634	Name Plate	1	CA52	141 2 8519 31900	Spring, Slide Base	1
131	2 3608 14100	Cramp Wire	4	CA53	141 2 3519 67400	Angle Mount(Photo C)	1
131	2 7103 46800	Label	1	CA54	141 2 8539 53800	Spring Plate	1
131	2 7103 47900	Label	1	CA55	131 2 4201 20800	Screw, +M2.6x6	1
131	6 4559 10900	Manufacturing No	1	CA56	131 2 4201 19500	Screw, Button Hd. Tapping	3
141	6 4729 37447	Stylus Label	1	CA57	131 2 4201 19504	Screw, Button Hd. Tapping	1
CA1	141 0 1249 30600	Lid Assy	1	CA58	141 0 5519 10300	Worm Assy	2
CA2	131 0 2002 16800	Hinge Assy	1	CA59	141 2 5649 22600	Belt	1
CA3	141 2 4429 00201	Mat Turntable	1	CA60	141 2 8519 60000	Spring Plate	1
CA4	141 2 5229 00401	Turntable	1	CA61	134 2 4201 12800	Screw	1
CA5	131 2 4201 20702	Screw, +M3.0x35	5	CA62	141 2 7519 64000	Spindle Lifting	1
CA6	141 2 1219 29500	Panel Front	1	CA63	141 2 5519 52100	Worm Wheel(A)	1
CA7	141 2 1329 14200	Filter	1	CA64	141 2 3519 67100	Angle Mount(Motor)	2
CA8	131 2 6113 51000	Shelter	1	CA65	141 2 4459 31800	Cushion	4
CA9	131 2 6113 51100	Shelter	1	CA66	4 5272 00181	Comutate MTR Magnet (Arml [M3])	1
CA10	141 2 1329 14300	Filter	1	CA67	4 2319 76680	Leaf Switch (Lift Up) [S1]	1
CA11	141 2 1439 14100	Panel Control	1	CA67	4 2319 76680	Leaf Switch (Lift Down) [S2]	1
CA12	△ 4 2432 00071	Power Cord	1	CA68	141 2 3519 66900	Cover(Holder)	1
CA13	131 2 6111 21300	Bushing	1	CA69	141 2 3519 67500	Plate(Filter)	1
CA14	141 2 1659 35600	Knob	1	CA70	141 2 3519 66800	LED Holder	1
CA15	141 2 1659 35800	Knob	1	CA71	141 2 4219 06300	Screw	1
CA16	131 2 4201 21100	Screw	7	CA72	134 2 5101 32400	Spring	1
CA17	131 0 4004 16101	Wire Shield Assy	1	CA73	141 2 3519 67000	LED Holder Base	1
CA18	141 2 1439 13900	Panel Control	1	CA74	141 0 6419 01200	Pick-up Assy	1
CA19	131 2 2904 11000	Pad Lid	2	CA74-1	141 0 6419 01300	Tone Arm Assy	1
CA20	131 2 4201 20705	Screw, Bdg Hd. Tapping	14	CA74-2	4 1579 70030	Cartridge Assy	1
CA21	131 2 4201 23703	Screw	6	1	4 1579 70040	Cartridge (MG-102S)	1
CA22	141 2 1129 08801	Cabinet	1	2	4 1579 70050	Stylus (ST-102SD)	1
CA23	141 2 1149 37400	Cover PCB	1	CA74-3	141 2 6459 00300	Retainer Needle	1
CA24	131 2 4201 19501	Screw, Button Hd. Tapping	19	CA75	134 2 5101 26500	Spring	1
CA25	134 0 5011 03600	Motor Assy (Phono) [M1]	1	CA76	141 2 4579 05000	Washer, M3.2x10x0.2	1
CA26	141 2 4459 31800	Cushion	4	CA77	141 2 3519 70300	Angle Mount	1
				CA78	131 2 4112 10200	Rope	1
				CA79	141 2 7319 58000	Holder Slide	1
				CA80	134 2 4106 27000	Shaft	1
				CA81	141 2 5519 52200	Worm Whell(B)	1
				CA82	141 2 5649 24700	Belt	1
				CA83	141 2 5739 07000	Support Shaft	1
				CA84	131 0 3020 11800	Pully Assy	3



CABINET & TURNTABLE PARTS LIST (Continued)

Ref. No.	Part No.	Description	Q'ty
CA85	141 2 3519 69000	Angle Mount	1
CA86	141 2 8519 33300	Spring, Lock Caset Case	1
CA87	141 2 3169 23200	Frame	1
CA88	141 2 3519 69100	Angle Mount	1
CA89	141 2 4459 33200	Cushion	2
CA90	141 2 5289 01600	Rail	1
CA91	4 2319 77560	Leaf Switch (Return) [S3]	1
CA92	141 2 3169 22200	Guide Angle	1
CA93	141 2 3519 72200	Angle Mount	1
CA94	141 2 1259 07401	Plate Bottom	1
CA95	4 5272 00180	Comutate MTR Magnet (Lifter) [M2]	1
CA96	131 2 4201 20300	Screw	1
CA97	131 2 7104 00101	Plate Pad Switch	1
CA98	△ 4 2312 02650	Switch Slide (Voltage Select) [S5]	1
CX1	101 3 1302 00311	Screw, Pan Hd., +M2.0x3	4
CX2	101 3 1303 03011	Screw, Pan Hd., +M3.0x30	1
CX3	103 3 1303 00511	Screw, Pan Hd. Tapping-2, +M3.0x5	4
CX4	103 3 1904 00611	Screw, Brazier Hd. Tapping-2, +M4.0x6	2
CX5	143 3 1702 00618	Screw, Bind Hd. Tapping-B, +M2.0x6	1
CX6	143 3 1702 00818	Screw, Bind Hd. Tapping-B, +M2.0x8	2
CX7	112 3 1302 00011	E Ring, M2.0	1
CX8	110 3 2104 00011	Spring Washer-2, M4.0	1
CX9	106 3 1204 00311	Hex. Nut-2, M4.0	1
PCB1	141 0 1939 05800	Control P.C.B. Assy	1
PCB2	141 0 1939 02710	PCR P.C.B. Assy	1
PCB3	141 0 1939 02721	PTR P.C.B. Assy	1
PCB4	141 0 1939 02731	LED P.C.B. Assy	1
PCB5	141 0 1939 05471	Terminal P.C.B. Assy	1
PCB6	141 0 1939 05900	Sub Control P.C.B. Assy	1
PCB7	141 0 1939 06000	Touch Switch P.C.B. Assy	1
PCB8	141 0 1939 06100	Manual Switch P.C.B. Assy	1
PCB9	141 0 1939 06200	Slide Switch P.C.B. Assy	1
PCB10	141 0 1939 06300	Auto Function Jack P.C.B. Assy	1
PCB11	141 0 1939 06500	Power Supply P.C.B. Assy	1

NOTE:

1. Parts order must contain Model Number, Part Number and Description.
2. Ordering quantity of screws and resistors must be multiple of 10 pcs.

PRODUCT SAFETY NOTICE

Each precaution in this manual should be followed during servicing. Components identified with the IEC symbol  in the parts list and the schematic diagram designate components in which safety can be of special significance. When replacing a component identified with , use only the replacement parts designated, or parts with the same ratings of resistance, wattage or voltage that are designated in the parts list in this manual. Leakage-current or resistance measurements must be made to determine that exposed parts are acceptably insulated from the supply circuit before returning the product to the customer.

FUNCTIONAL DESCRIPTION

MICROCOMPUTER PORTS AND FUNCTIONS

Port No.	Functions	Actions	Port No.	Functions	Actions
PA0	INTRO LED	"L"...ON	PF2	TR-7 LED	"L"...ON
PA1	TR-9 LED	"L"...ON	PF3	TR-8 LED	"L"...ON
PA2	Lift Down SW.	"H"...ON	PG0	Phono Motor	"L"...ON
PA3	Lift Up SW.	"H"...ON	PG1	Speed	"L"...45rpm "H"...33rpm
PB0~PB2	Arm Position		PG2	Arm Motor (left)	"L"...ON
PC0~PC3	Key Scan		PG3	Arm Motor (right)	"L"...ON
PD0~PD3	Key Scan		PH0	Lifter Motor (down)	"L"...ON
PE0	TR-1 LED	"L"...ON	PH1	Lifter Motor (up)	"L"...ON
PE1	TR-2 LED	"L"...ON	PH2	Muting Relay	"H"...ON
PE2	TR-3 LED	"L"...ON	PH3	Repeat	"L"...ON
PE3	TR-4 LED	"L"...ON	PI0	Reflector	"L"...reflected
PF0	TR-5 LED	"L"...ON	PI1	Back Pulse for lead in	"H"...OFF
PF1	TR-6 LED	"L"...ON	PI2	Signal (sound)	"L"...signaled

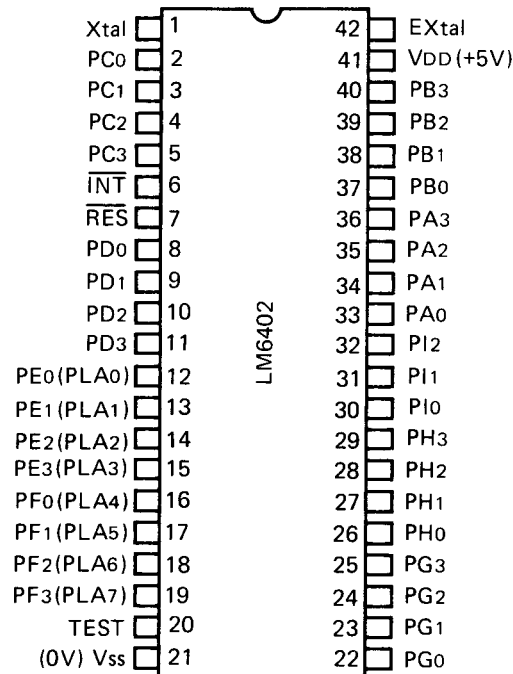

FUNCTIONAL DESCRIPTION (Continued)

Key Scan

The microcomputer analyzes the combinations of the four output and input ports (4 x 4 = 16 ports in total) and detects which one of the sixteen buttons (START/REJECT, REPEAT, INTRO SCAN, etc.,) on the control panel was pressed.

The output ports are PC0 ~ PC3 and the input ports PD0 ~ PD3 in the chart below.

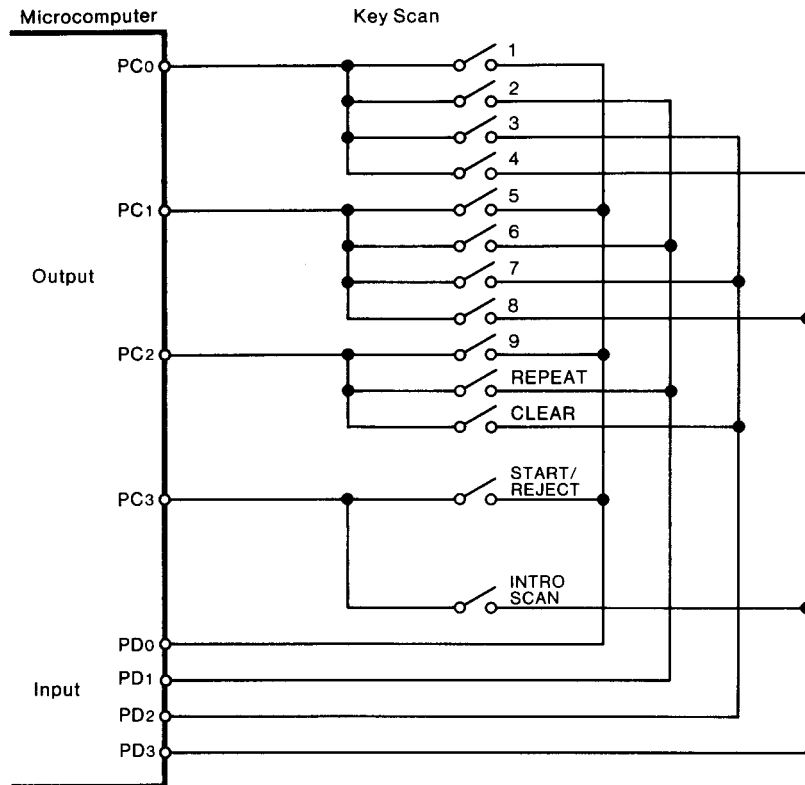

Input Ports PD0 ~ PD3 are normally kept in "H" (high) level and Output Ports PC0 ~ PC3 output the signals of "L" (low) level in the cycles as illustrated. When a port is in "L" level, the other ports are kept in "H" level.

If Button 1 is pressed and Output Port PC0 is set in "L" level, Input Port PD0 becomes "L" level. If Button 5 is pressed and Output Port PC1 is set in "L" level, Input Port PD0 becomes "L" level. Thus, the microcomputer analyzes how the input and output ports are combined and detects which button was pressed according to the combination.

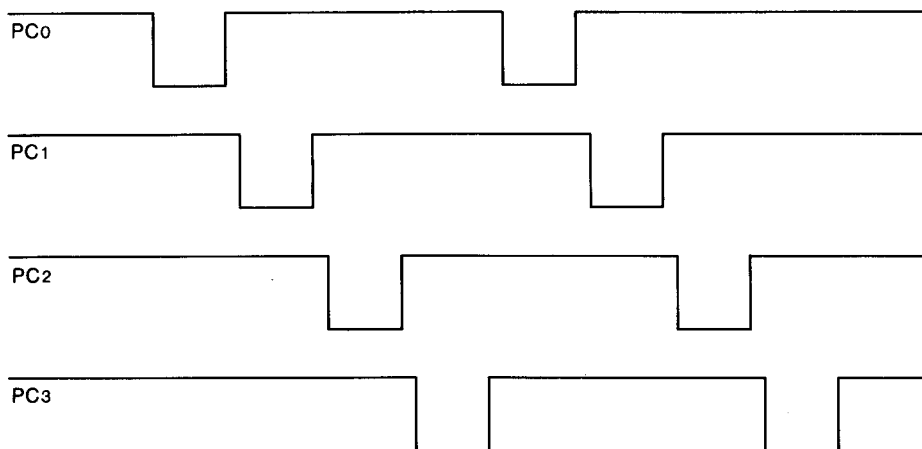

FUNCTIONAL DESCRIPTION (Continued)

Arm Position and Microcomputer Ports

The arm position is detected by the three pairs of LED's and phototransistors which run across the guide angle, and a pair of LED and a phototransistor mounted on the pickup. Illustrated below is the hole arrangement of the three pairs of sensors which run across the guide angle and the guide angle. See the chart for the relation between each port.

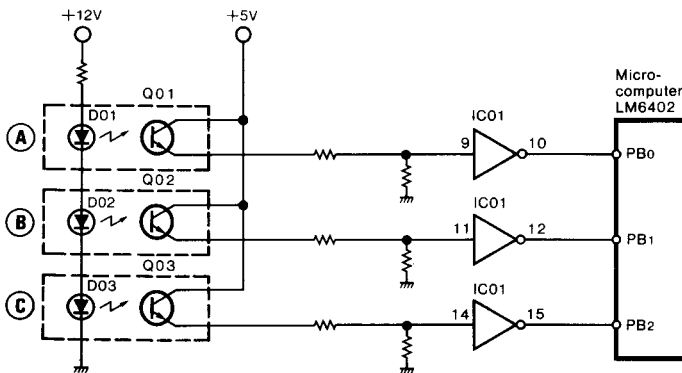
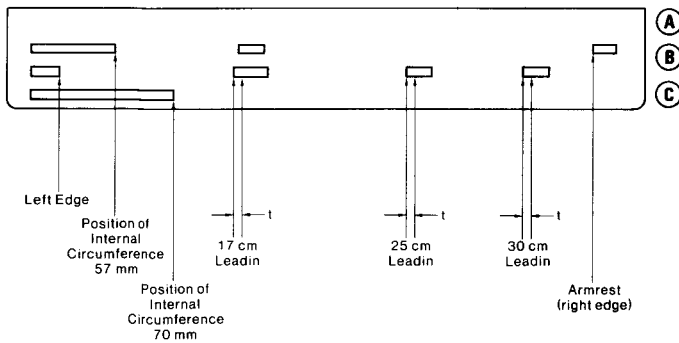

	Left Edge	Internal Circumference 57mm	Internal Circumference 70mm	Armrest (Right Edge)
PB0	"L"(Low Level)	"L"(Low Level)	"H"(High Level)	"L"(Low Level)
PB1	"L"(Low Level)	"H"(High Level)	"H"(High Level)	"H"(High Level)
PB2	"L"(Low Level)	"L"(Low Level)	"L"(Low Level)	"H"(High Level)

30 cm Leadin

The arm is shifted until PB1 is set in "H" level (at the end of the square hole) if PLo is set in "L" level by the signals emitted from the sensor on the pickup when PB0 is in "H", PB1 in "L", and PB2 in "H" levels.

When PB1 is set in "H" level, the arm stops once (Port PG2: "H") and returns (Port PG3: "L") for a period of time determined by C22 (4.7μF/25) and VRO1 (100K-B).

If the arm returns for a certain period of time, it stops (Port PG3: "H") and lowers on the disc (Port PHo: "L").

Note:

If the sensor on the pickup is located over the disc, the light is reflected and Port PLo is set in "L" level. If a disc is not placed on the turntable, the light is not reflected and Port PLo is set in "H" level.

25 cm Leadin

As PLo is set in "H" level at the square hole for 30 cm, the arm advances inwards until it reaches the square hole for 25 cm. Then, the arm exercises the same action as those in 30 cm leadin and lowers on the disc.

17 cm Leadin

When PB0 is in "L", PB1 in "L", and PB2 in "H" levels, the arm is shifted until PB1 is set in "H" level if Port PLo is set in "L" level by the signals emitted from the sensor on the pickup. Then, the arm exercises the same actions as those in 30 cm leadin.

Return Conditions

The return action is taken place when the following conditions are met.

- (1) when the stylus tip reaches the area of 57 mm or more away from the internal circumference of the disc. (PB0: "L", PB1: "H", PB2: "L")
- (2) when there is no music signal. (PI2: "H")
- (3) The light is reflected to the sensor with the pickup in "DOWN" mode. (Plo: "L")

When the unit is operated without any programming and the above described three conditions are met at the same time, the return action is taken place.

When the reproduction of the last program is finished by the programmed action, the return action is taken place if the above described conditions (2) and (3) are met at the same time.

Conditions of Direct Music Selection

Direct music selection is taken place when the following conditions are met at the same time. In other cases, select a program after the tonearm has rested on the armrest once.

- (1) when a program is finished at the area of more than 70 mm away from the internal circumference of the disc.
- (2) when the program to be selected next is not the first one.
- (3) when music signals exist for more than 10 sec.

ADJUSTMENT PROCEDURES

Measuring Instruments Required

- DC VTVM (DC Voltmeter with high input impedance)
- Standard Reflector
- Stylus pressure Meter
- Record Disc (Disc with many programs is desirable.)
- Plus Screwdriver, Minus Screwdriver

• Stylus Pressure Adjustment

1. Place the unit on a level surface and remove the lid.
2. Turn on the power switch of the unit.
3. Push \triangleleft button on the control panel and move the arm to the place as illustrated in Fig. 1.
4. Adjust the stylus pressure adjustment screw (Fig. 2) through the adjustment hole, so that the stylus pressure becomes 1.8 ~ 2.2 g.

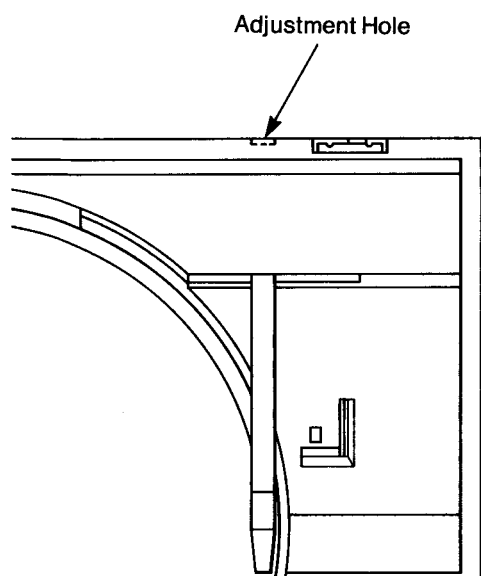

Fig. 1

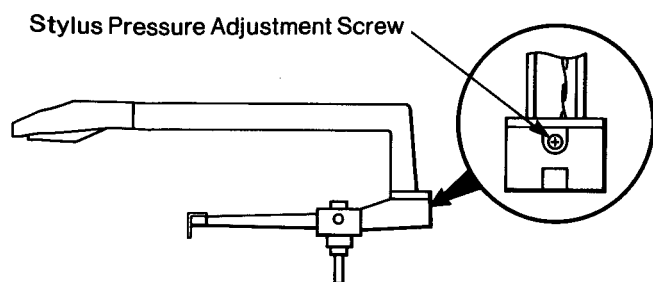

Fig. 2

• Tonearm Position Adjustment

1. Remove the lid and the turntable.
2. Turn on the power switch of the unit.
3. Push the \triangleleft button on the control panel and move the tonearm to the place where the tonearm position adjustment cam can be observed. (Fig. 3)
4. Adjust the tonearm position adjustment cam, so that the tonearm faces perpendicular to the back wall of the cabinet. (Fig. 3)

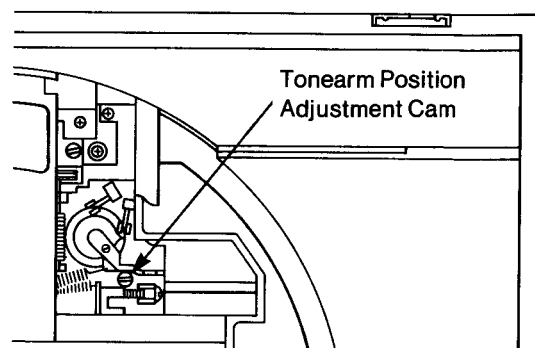

Fig. 3

• Stylus Height Adjustment

1. Remove the lid and the turntable mat.
2. Turn on the power switch of the unit.
3. Push the \triangleleft button on the control panel and move the tonearm to the place where the stylus height adjustment screw can be observed. (Fig. 4)
4. Adjust the stylus height to the place 6 ± 0.5 mm above the turntable.

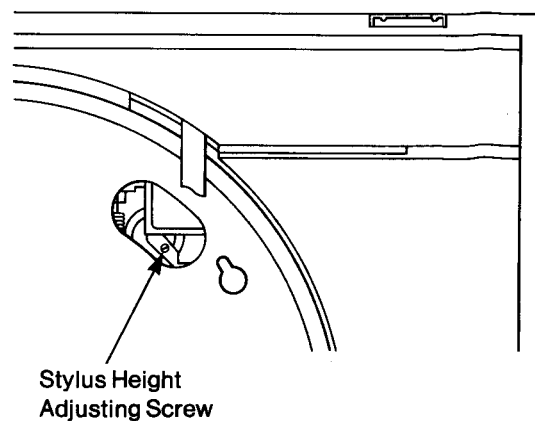

Fig. 4

ADJUSTMENT PROCEDURES (Continued)

• Arm Trace Confirmation

1. Turn on the power switch of the unit.
2. Place a disc on the turntable and set the number of rotations to 45 r.p.m.
3. Confirm that the tonearm correctly traces from the beginning to the final silent groove.
4. If not, cut off R93 (3.3k Ω) on the Control P.C.Board and perform the re-confirmation. (Fig. 8)

• Arm Feed Photointerrupter Position Adjustment

1. Turn on the power switch of the unit.
2. Place a disc with little eccentricity on the turntable and play it back.
3. After the disc has been rotated 3 or 4 times, push the CUEING button to elevate the tonearm.
4. At this time, adjust the arm feed screw through the right hole on the cabinet with a screwdriver, so that the tonearm is elevated straight up. (Fig. 5)

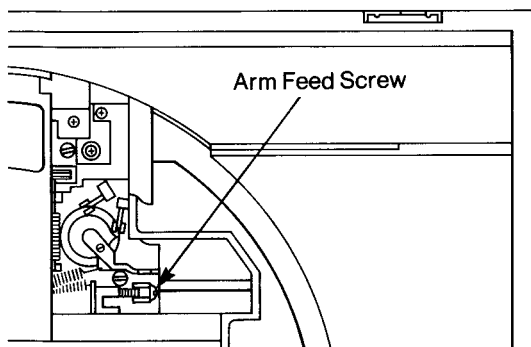

Fig. 5

• Track Sensor Sensitivity Adjustment

1. Short-circuit between TP1 (GND) and TP4. (When the tonearm is placed on the turntable, the turntable does not rotate.)
2. Connect the DC VTVM's between TP2 and GND and between TP3 and GND. (Fig. 7)
3. Place the standard reflective plate on the center between the turntable shaft and turntable edges.
4. Turn on the power switch of the unit.
5. Move the tonearm to the place above the standard reflective plate. Lower the tonearm on the plate with the CUEING button.
6. Adjust VR11, so that the voltage of TP3 becomes 3.5V.
7. Elevate the tonearm with the CUEING button. At this time, adjust VR12, so that the voltage of TP2 becomes 3.8V.

Note:

If the proper sensitivity is not obtained, cut off R105 and perform the re-adjustment.

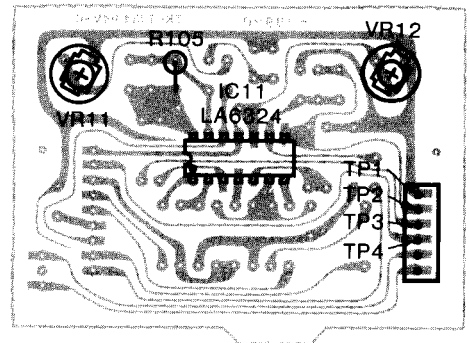

Fig. 6

• Leadin Adjustment

1. Turn on the power switch of the unit.
2. Place a disc on the turntable and push the START button.
3. Adjust VR01 through the hole on the cabinet bottom, so that the tonearm is correctly led into the disc. (Fig. 7)

• Approach Adjustment

1. Turn on the power switch of the unit.
2. Keep the approach knob in the center click position.
3. Select the 2nd ~ 6th programs and adjust VR02, so that the last portion of the previous program is not reproduced or music is not reproduced on its way. (Fig. 7)

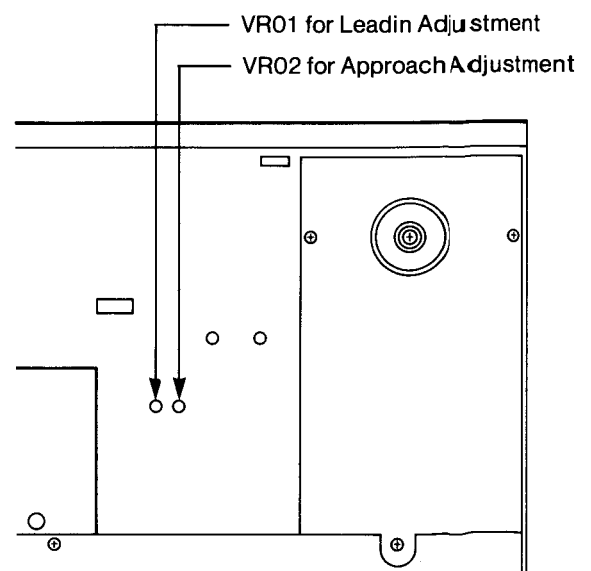

Fig. 7

ADJUSTMENT PROCEDURES (Continued)

P.C.BOARD PARTS LIST

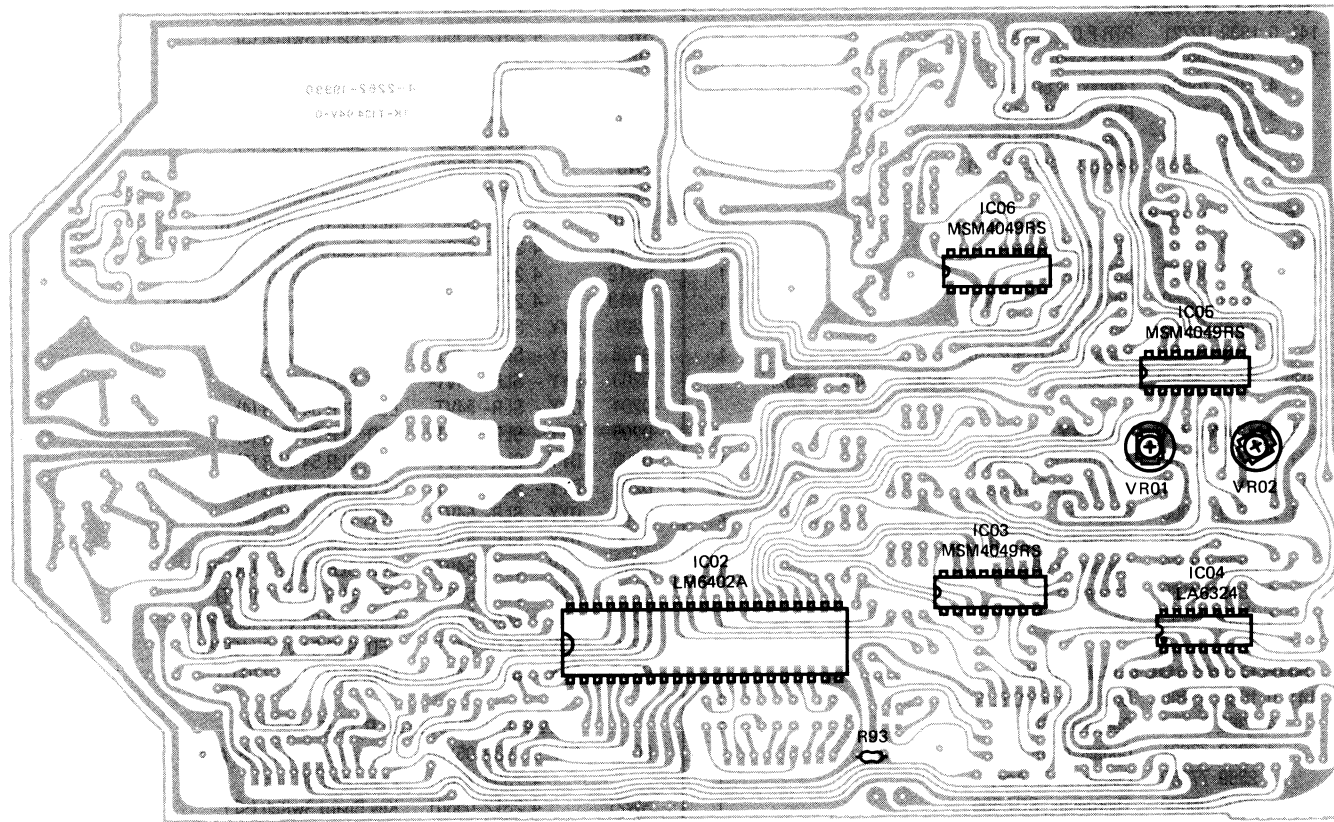

Fig. 8

Ref. No.	Part No.	Description	Q'ty	Ref. No.	Part No.	Description	Q'ty
CONTROL P.C.B. ASSY							
PCB1	141 0 1939 05800	Control P.C.B. Assy	1	D8	202 5 3160 00110	Diode, GMA 01	1
	4 2252 00090	CSB400P	1	D9	202 5 3160 00110	Diode, GMA 01	1
	101 3 1303 00611	Screw, Pan Hd., +M3.0x6	2	D11	205 5 9040 44210	Diode, DS 442	1
	103 3 1903 00611	Screw, Brazier Hd. Tapping-2, +M3.0x6	1	D12	205 5 9040 44210	Diode, DS 442	1
	111 2 6220 11100	Wire Wrap Terminal	13	D13	205 5 9040 44210	Diode, DS 442	1
	131 2 6201 21500	Plate Heat Sink (for IC7)	1	D14	205 5 9040 44210	Diode, DS 442	1
	131 2 6201 35400	Plate Heat Sink (for IC8)	1	D15	202 5 3160 00110	Diode, GMA 01	1
	131 2 6201 35500	Plate Heat Sink (for IC9)	1	D16	202 5 3160 00110	Diode, GMA 01	1
CN1	4 2369 73130	Connector 3P	1	D17	205 5 9040 44210	Diode, DS 442	1
CN3	4 2369 73160	Connector 6P	1	D18	205 5 9040 44210	Diode, DS 442	1
CN4	4 2369 73130	Connector 3P	1	D19	DGG - W02 - - - - -	Diode, W 02	1
CN5	4 2362 00400	Plug 7P	1	D20	202 5 2470 13540	Diode, DS 135	1
CN6	4 2369 73690	Plug 9P	2	D21	205 5 9040 44210	Diode, DS 442	1
CN7	4 2362 00410	Plug 8P	1	D22	205 5 9040 44210	Diode, DS 442	1
CN8	4 2369 73160	Connector 6P	1	D23	205 5 9040 44210	Diode, DS 442	1
CN9	4 2369 71901	Connector 12P Top	1	D24	205 5 9040 44210	Diode, DS 442	1
CN10	4 2359 77660	Connector 5P Assy	1	D25	202 5 3160 00110	Diode, GMA 01	1
VR1	4 2222 02680	Semi Fixed (B-100kΩ)	1	D51	205 5 9040 44210	Diode, DS 442	1
VR2	4 2222 02670	Semi Fixed (B-47kΩ)	1	D52	205 5 9040 44210	Diode, DS 442	1
RE1	4 2329 70310	Reed Relay	1	D53	205 5 9040 44210	Diode, DS 442	1
L1	4 2532 00540	Choke Coil (47μH)	1	D54	205 5 9040 44210	Diode, DS 442	1
TH1	204 5 9000 05000	Thermistor, SDT 500	1	D55	202 5 3210 10012	Zener Diode, GZA 10Y	1
IC1	4 2069 72530	IC, MSM 4049 RS	1	C4	CD3 3 4500 0001V	Electrolytic	0.33μF 50V
IC2	208 5 4016 40229	IC, LM6402A-292	1	C5	CD1 0 4500 0001V	Electrolytic	0.1μF 50V
IC3	4 2069 72530	IC, MSM 4049 RS	1	C8	CM1 0 4500 J00TV	Mylar	0.1μF 50V ±5%
IC4	206 5 1296 32410	IC, LA 6324	1	C9	CD4 7 6100 0001V	Electrolytic	47μF 10V
IC5	4 2069 72530	IC, MSM 4049 RS	1	C10	CC1 0 3501 YEYOC	Ceramic	0.01μF 500V +100,-0%
IC6	4 2069 72530	IC, MSM 4049 RS	1	C11	4 2239 71360	Electrolytic	1000μF 25V
IC7	206 5 2040 07805	IC, L78M05	1	C12	CD4 7 7250 0006V	Electrolytic	470μF 25V
IC8	4 2069 72560	IC, NJM 7812	1	C13	CC1 0 3500 ZG00C	Ceramic	0.01μF 50V +80,-20%
IC9	4 2069 72570	IC, NJM 7912	1	C14	CC1 0 3500 ZG00C	Ceramic	0.01μF 50V +80,-20%
Q1	203 5 5000 53650	Transistor, 2SC 536	1	C15	CD1 0 7160 0001V	Electrolytic	100μF 16V
Q2	203 5 5000 53650	Transistor, 2SC 536	1	C16	CD1 0 7160 0001V	Electrolytic	100μF 16V
Q3	203 5 7340 86350	Transistor, 2SD 863	1	C17	CM1 0 4500 J00TV	Mylar	0.1μF 50V ±5%
Q4	203 5 7350 76450	Transistor, 2SB 764	1	C18	CM1 0 4500 J00TV	Mylar	0.1μF 50V ±5%
Q5	203 5 7340 86350	Transistor, 2SD 863	1	C19	CC3 3 1500 KD00C	Ceramic	330pF 50V ±10%
Q6	203 5 7350 76450	Transistor, 2SB 764	1	C20	CM1 0 3500 K00SV	Mylar	0.01μF 50V ±10%
Q7	203 5 5000 53650	Transistor, 2SC 536	1	C21	CI1 0 3250 NF00R	Boundary	0.01μF 25V ±30%
Q8	203 5 5000 53650	Transistor, 2SC 536	1	C22	CD1 0 6250 0001V	Electrolytic	10μF 25V
Q9	203 5 5000 53650	Transistor, 2SC 536	1	C23	CD3 3 5500 KHS1V	Electrolytic	3.3μF 50V ±10%
Q10	203 5 5000 53650	Transistor, 2SC 536	1	C24	CM1 0 3500 K00SV	Mylar	0.01μF 50V ±10%
Q11	203 5 5000 53650	Transistor, 2SC 536	1	C25	CC3 3 1500 KD00C	Ceramic	330pF 50V ±10%
Q12	203 5 7230 60850	Transistor, 2SA 608	1	C26	CI1 0 3250 NF00R	Boundary	0.01μF 25V ±30%
Q13	203 5 7230 60850	Transistor, 2SA 608	1	C27	CI1 0 3250 NF00R	Boundary	0.01μF 25V ±30%
Q14	203 5 7230 60850	Transistor, 2SA 608	1	C28	CD2 2 5500 0001V	Electrolytic	2.2μF 50V
Q15	203 5 7230 60850	Transistor, 2SA 608	1	C29	CD2 2 5500 0001V	Electrolytic	2.2μF 50V
Q16	203 5 7230 60850	Transistor, 2SA 608	1	C30	CC1 0 1500 KD00C	Ceramic	100pF 50V ±10%
Q17	203 5 5000 53650	Transistor, 2SC 536	1	C31	CM1 0 3500 K00SV	Mylar	0.01μF 50V ±10%
Q18	203 5 5000 53650	Transistor, 2SC 536	1	C32	CD1 0 6160 0001V	Electrolytic	10μF 16V
Q19	203 5 5000 53650	Transistor, 2SC 536	1	C33	CD1 0 5500 0001V	Electrolytic	1μF 50V
Q20	203 5 5000 53650	Transistor, 2SC 536	1	C34	CD2 2 6160 0001V	Electrolytic	22μF 16V
Q51	203 5 5000 53650	Transistor, 2SC 536	1	C35	CD4 7 6100 0001V	Electrolytic	47μF 10V
Q52	203 5 5000 53650	Transistor, 2SC 536	1	C36	CD1 0 6160 0001V	Electrolytic	10μF 16V
Q53	203 5 5000 53650	Transistor, 2SC 536	1	C37	CM2 7 3500 K00SV	Mylar	0.027μF 50V ±10%
Q54	203 5 5000 53650	Transistor, 2SC 536	1	C38	CD4 7 5250 0001V	Electrolytic	4.7μF 25V
Q55	203 5 5000 53650	Transistor, 2SC 536	1	C39	CM1 0 4500 J00TV	Mylar	0.1μF 50V ±5%
D1	205 5 9040 44210	Diode, DS 442	1	C40	CP2 2 1101 J003V	Polypropylen	220pF 100V ±5%
D2	205 5 9040 44210	Diode, DS 442	1	C41	CP2 2 1101 J003V	Polypropylen	220pF 100V ±5%
D3	202 5 3160 00110	Diode, GMA 01	1	C42	CD4 7 6250 0001V	Electrolytic	47μF 25V
D4	205 5 9040 44210	Diode, DS 442	1	C43	CD4 7 5500 0001V	Electrolytic	4.7μF 50V
D5	205 5 9040 44210	Diode, DS 442	1	C44	CC4 7 3500 ZG00C	Ceramic	0.047μF 50V +80,-20%
D6	205 5 9040 44210	Diode, DS 442	1	C45	CI2 2 3160 NG00R	Boundary	0.022μF 16V ±30%
D7	202 5 3160 00110	Diode, GMA 01	1	C46	CI2 2 3160 NG00R	Boundary	0.022μF 16V ±30%
				C47	CI2 2 3160 NG00R	Boundary	0.022μF 16V ±30%

P.C.BOARD PARTS LIST (Continued)

Ref. No.	Part No.	Description	Q'ty	Ref. No.	Part No.	Description	Q'ty	
C48	CI2 2 3160	NG00R Boundary	0.022μF 16V ±30%	1	R62	RD3 9 1161 JH000	Carbon 390Ω 1/6W ±5%	1
C51	CD2 2 5500	0001V Electrolytic	2.2μF 50V	1	R63	RD3 9 1161 JH000	Carbon 390Ω 1/6W ±5%	1
C52	CD1 0 5500	0001V Electrolytic	1μF 50V	1	R64	RD3 9 1161 JH000	Carbon 390Ω 1/6W ±5%	1
C53	CD1 0 5500	0001V Electrolytic	1μF 50V	1	R65	RD3 9 1161 JH000	Carbon 390Ω 1/6W ±5%	1
R1	RH4 7 1102	JZ000 Metal	470Ω 1W ±5%	1	R66	RD3 9 1161 JH000	Carbon 390Ω 1/6W ±5%	1
R2	RD1 0 3161	JH000 Carbon	10kΩ 1/6W ±5%	1	R67	RD3 9 1161 JH000	Carbon 390Ω 1/6W ±5%	1
R3	RD1 0 3161	JH000 Carbon	10kΩ 1/6W ±5%	1	R68	RD3 9 1161 JH000	Carbon 390Ω 1/6W ±5%	1
R4	RD1 0 3161	JH000 Carbon	10kΩ 1/6W ±5%	1	R69	RD1 0 3251 JM000	Carbon 10kΩ 1/4W ±5%	1
R5	RD1 0 4161	JH000 Carbon	100kΩ 1/6W ±5%	1	R70	RD1 0 3251 JM000	Carbon 10kΩ 1/4W ±5%	1
R6	RD1 0 4161	JH000 Carbon	100kΩ 1/6W ±5%	1	R71	RD2 2 3251 JM000	Carbon 22kΩ 1/4W ±5%	1
R7	RD1 0 4161	JH000 Carbon	100kΩ 1/6W ±5%	1	R72	RD2 2 3251 JM000	Carbon 22kΩ 1/4W ±5%	1
R8	RD3 3 2251	JM000 Carbon	3.3kΩ 1/4W ±5%	1	R73	RD3 9 1251 JM000	Carbon 390Ω 1/4W ±5%	1
R9	RD1 0 4161	JH000 Carbon	100kΩ 1/6W ±5%	1	R74	RD3 9 1251 JM000	Carbon 390Ω 1/4W ±5%	1
R10	RD2 2 2251	JM000 Carbon	2.2kΩ 1/4W ±5%	1	R75	RD2 2 3251 JM000	Carbon 22kΩ 1/4W ±5%	1
R11	RD1 0 3251	JM000 Carbon	10kΩ 1/4W ±5%	1	R76	RD2 2 3251 JM000	Carbon 22kΩ 1/4W ±5%	1
R12	RD1 0 3161	JH000 Carbon	10kΩ 1/6W ±5%	1	R77	RD2 2 1251 JM000	Carbon 220Ω 1/4W ±5%	1
R13	RD1 0 3161	JH000 Carbon	10kΩ 1/6W ±5%	1	R78	RD3 9 1251 JM000	Carbon 390Ω 1/4W ±5%	1
R14	RD4 7 3161	JH000 Carbon	47kΩ 1/6W ±5%	1	R79	RD3 9 1251 JM000	Carbon 390Ω 1/4W ±5%	1
R15	RD4 7 2161	JH000 Carbon	4.7kΩ 1/6W ±5%	1	R80	RD2 2 3251 JM000	Carbon 22kΩ 1/4W ±5%	1
R16	RD4 7 2161	JH000 Carbon	4.7kΩ 1/6W ±5%	1	R81	RD2 2 3161 JH000	Carbon 22kΩ 1/6W ±5%	1
R17	RD2 7 2251	JM000 Carbon	2.7kΩ 1/4W ±5%	1	R82	RD1 8 3161 JH000	Carbon 18kΩ 1/6W ±5%	1
R18	RD8 2 1251	JM000 Carbon	820Ω 1/4W ±5%	1	R83	RD2 2 3251 JM000	Carbon 22kΩ 1/4W ±5%	1
R19	RD2 2 2161	JH000 Carbon	2.2kΩ 1/6W ±5%	1	R84	RD2 2 3251 JM000	Carbon 22kΩ 1/4W ±5%	1
R20	RD4 7 1161	JH000 Carbon	470Ω 1/6W ±5%	1	R85	RD1 8 3161 JH000	Carbon 18kΩ 1/6W ±5%	1
R21	RD3 9 A251	JM000 Carbon	3.9Ω 1/4W ±5%	1	R86	RD2 2 3161 JH000	Carbon 22kΩ 1/6W ±5%	1
R22	RD4 7 1161	JH000 Carbon	470Ω 1/6W ±5%	1	R87	RD1 0 3251 JM000	Carbon 10kΩ 1/4W ±5%	1
R23	RD4 7 1161	JH000 Carbon	470Ω 1/6W ±5%	1	R88	RD1 0 3161 JH000	Carbon 10kΩ 1/6W ±5%	1
R24	RD1 0 2161	JH000 Carbon	1kΩ 1/6W ±5%	1	R89	RD1 0 4251 JM000	Carbon 100kΩ 1/4W ±5%	1
R25	RD3 3 2161	JH000 Carbon	3.3kΩ 1/6W ±5%	1	R90	RD6 8 2251 JM000	Carbon 6.8kΩ 1/4W ±5%	1
R26	RH2 7 0202	JZ000 Metal	27Ω 2W ±5%	1	R91	RD1 0 4251 JM000	Carbon 100kΩ 1/4W ±5%	1
R27	RH4 7 1102	JZ000 Metal	470Ω 1W ±5%	1	R92	RD1 0 3251 JM000	Carbon 10kΩ 1/4W ±5%	1
R28	RD1 0 2161	JH000 Carbon	1kΩ 1/6W ±5%	1	R93	RD3 3 2161 JH000	Carbon 3.3kΩ 1/6W ±5%	1
R29	RD1 0 2161	JH000 Carbon	1kΩ 1/6W ±5%	1	R94	RD1 2 2251 JM000	Carbon 1.2kΩ 1/4W ±5%	1
R30	RD3 3 2251	JM000 Carbon	3.3kΩ 1/4W ±5%	1	R95	RD1 0 3161 JH000	Carbon 10kΩ 1/6W ±5%	1
R31	RD1 0 2251	JM000 Carbon	1kΩ 1/4W ±5%	1	R96	RD1 0 3161 JH000	Carbon 10kΩ 1/6W ±5%	1
R32	RD4 7 1161	JH000 Carbon	470Ω 1/6W ±5%	1	R97	RD1 0 4251 JM000	Carbon 100kΩ 1/4W ±5%	1
R33	RD2 2 2161	JH000 Carbon	2.2kΩ 1/6W ±5%	1	R98	RD1 0 3161 JH000	Carbon 10kΩ 1/6W ±5%	1
R34	RD3 9 A251	JM000 Carbon	3.9Ω 1/4W ±5%	1	R99	RD1 0 0251 JS000	Carbon 10Ω 1/4W ±5%	1
R35	RD4 7 1161	JH000 Carbon	470Ω 1/6W ±5%	1	R201	RD2 2 2161 JH000	Carbon 2.2kΩ 1/6W ±5%	1
R36	RD4 7 1161	JH000 Carbon	470Ω 1/6W ±5%	1	R202	RD2 2 3161 JH000	Carbon 22kΩ 1/6W ±5%	1
R37	RD1 0 2161	JH000 Carbon	1kΩ 1/6W ±5%	1	R203	RD1 8 3251 JM000	Carbon 18kΩ 1/4W ±5%	1
R38	RD1 0 4251	JM000 Carbon	100kΩ 1/4W ±5%	1	R205	RD4 7 3161 JH000	Carbon 47kΩ 1/6W ±5%	1
R39	RD1 0 2161	JH000 Carbon	1kΩ 1/6W ±5%	1	R206	RD4 7 3161 JH000	Carbon 47kΩ 1/6W ±5%	1
R40	RD1 0 4251	JM000 Carbon	100kΩ 1/4W ±5%	1	R207	RD1 0 4161 JH000	Carbon 100kΩ 1/6W ±5%	1
R41	RD6 8 2251	JM000 Carbon	6.8kΩ 1/4W ±5%	1	R208	RD1 0 2251 JM000	Carbon 1kΩ 1/4W ±5%	1
R42	RD1 0 2251	JM000 Carbon	1kΩ 1/4W ±5%	1	R209	RD1 0 4161 JH000	Carbon 100kΩ 1/6W ±5%	1
R43	RD3 3 4161	JH000 Carbon	330kΩ 1/6W ±5%	1	R210	RD2 2 2161 JH000	Carbon 2.2kΩ 1/6W ±5%	1
R44	RD1 2 3161	JH000 Carbon	12kΩ 1/6W ±5%	1	R211	RD2 2 3161 JH000	Carbon 22kΩ 1/6W ±5%	1
R45	RD1 0 4251	JM000 Carbon	100kΩ 1/4W ±5%	1	R212	RD2 2 3161 JH000	Carbon 22kΩ 1/6W ±5%	1
R46	RD1 2 2161	JH000 Carbon	1.2kΩ 1/6W ±5%	1	R213	RD2 2 3161 JH000	Carbon 22kΩ 1/6W ±5%	1
R47	RD2 7 4161	JH000 Carbon	270kΩ 1/6W ±5%	1	R214	RD1 2 4161 JH000	Carbon 220kΩ 1/6W ±5%	1
R48	RD1 2 2161	JH000 Carbon	1.2kΩ 1/6W ±5%	1	R215	RD1 2 4161 JH000	Carbon 120kΩ 1/6W ±5%	1
R49	RD1 0 4161	JH000 Carbon	100kΩ 1/6W ±5%	1	R216	RD2 2 2161 JH000	Carbon 2.2kΩ 1/6W ±5%	1
R50	RD4 7 3251	JM000 Carbon	47kΩ 1/4W ±5%	1	R217	RD2 2 2161 JH000	Carbon 2.2kΩ 1/6W ±5%	1
R51	RD4 7 3161	JH000 Carbon	47kΩ 1/6W ±5%	1	R401	RD1 0 3161 JH000	Carbon 10kΩ 1/6W ±5%	1
R52	RD1 0 3251	JM000 Carbon	10kΩ 1/4W ±5%	1	R402	RD1 0 3251 JM000	Carbon 10kΩ 1/4W ±5%	1
R53	RD4 7 2251	JM000 Carbon	4.7kΩ 1/4W ±5%	1				
R55	RD6 8 2251	JM000 Carbon	6.8kΩ 1/4W ±5%	1				
R56	RD1 5 4161	JH000 Carbon	150kΩ 1/6W ±5%	1				
R57	RD1 2 2161	JH000 Carbon	1.2kΩ 1/6W ±5%	1				
R58	RD1 0 3251	JM000 Carbon	10kΩ 1/4W ±5%	1				
R59	RD1 0 5161	JH000 Carbon	1MΩ 1/6W ±5%	1				
R60	RD1 0 2251	JM000 Carbon	1kΩ 1/4W ±5%	1				
R61	RD3 9 1161	JH000 Carbon	390Ω 1/6W ±5%	1				

P.C.BOARD PARTS LIST (Continued)

Ref. No.	Part No.	Description	Q'ty	Ref. No.	Part No.	Description	Q'ty
		PTR P.C.B. ASSY					
PCB3	141 0 1939	02721 PTR P.C.B. Assy	1				
	141 2 3529	38900 LED Spacer	1				
CN12	4 2359	76606 Connector 6P Assy	1				
Q1	4 2039	71500 Photo TR SPS-103-01	1				
Q2	4 2039	71500 Photo TR SPS-103-01	1				
Q3	4 2039	71500 Photo TR SPS-103-01	1				
		LED P.C.B. ASSY					
PCB4	141 0 1939	02731 LED P.C.B. Assy	1				
	141 2 3529	38900 LED Spacer	1				
D1	4 2029	73160 Photo D. SLR-902A-01	1				
D2	4 2029	73160 Photo D. SLR-902A-01	1				
D3	4 2029	73160 Photo D. SLR-902A-01	1				
R1	RD5 6 1251	JM000 Carbon 560Ω 1/4W ±5%	1				
		TERMINAL P.C.B. ASSY					
PCB5	141 0 1939	05471 Terminal P.C.B. Assy	1				
	111 2 6220	11100 Wire Wrap Terminal	6				
	141 2 4729	05000 Staple 5	2				
CN11	4 2369	71901 Connector 12P Top	1				
CN12	4 2369	73160 Connector 6P	1				
CN13	4 2369	73130 Connector 3P	1				
CN14	4 2369	73140 Connector 4P	1				
		SUB CONTROL P.C.B. ASSY					
PCB6	141 0 1939	05900 Sub Control P.C.B. Assy	1				
	4 2369	71452 Connector 6P	1				
CN2	4 2359	77681 Connector 9P Assy	1				
CN4	4 2359	77369 Connector 3P Assy	1				
TH11	204 5 9000	05000 Thermistor, SDT 500	1				
VR11	4 2222	02690 Semi Fixed (B-220kΩ)	1				
VR12	4 2222	02670 Semi Fixed (B-47kΩ)	1				
C101	CM1 0 2500	K00SV Mylar 0.001μF 50V ±10%	1				
C102	CM1 0 2500	K00SV Mylar 0.001μF 50V ±10%	1				
C103	CD4 7 6100	0001V Electrolytic 47μF 10V	1				
IC11	206 5 1296	32410 IC, LA 6324	1				
D101	205 5 9040	44210 Diode, DS 442	1				
D102	205 5 9040	44210 Diode, DS 442	1				
R101	RD2 7 3161	JH000 Carbon 27kΩ 1/6W ±5%	1				
R102	RD2 7 3161	JH000 Carbon 27kΩ 1/6W ±5%	1				
R103	RD1 0 2161	JH000 Carbon 1kΩ 1/6W ±5%	1				
R104	RD1 2 4161	JH000 Carbon 120kΩ 1/6W ±5%	1				
R105	RD2 7 3251	JM000 Carbon 27kΩ 1/4W ±5%	1				
R106	RD4 7 3251	JM000 Carbon 47kΩ 1/4W ±5%	1				
R107	RD2 7 3161	JH000 Carbon 27kΩ 1/6W ±5%	1				
R108	RD3 3 4161	JH000 Carbon 330kΩ 1/6W ±5%	1				
R109	RD4 7 3251	JM000 Carbon 47kΩ 1/4W ±5%	1				
R110	RD1 0 3251	JM000 Carbon 10kΩ 1/4W ±5%	1				
R111	RD6 8 2251	JM000 Carbon 6.8kΩ 1/4W ±5%	1				
R112	RD2 2 3251	JM000 Carbon 22kΩ 1/4W ±5%	1				
R113	RD1 2 3251	JM000 Carbon 12kΩ 1/4W ±5%	1				
R114	RD4 7 3251	JM000 Carbon 47kΩ 1/4W ±5%	1				
R115	RD3 3 3251	JM000 Carbon 33kΩ 1/4W ±5%	1				
R116	RD5 6 2251	JM000 Carbon 5.6kΩ 1/4W ±5%	1				
R117	RD2 2 3251	JM000 Carbon 22kΩ 1/4W ±5%	1				
		TOUCH SWITCH P.C.B. ASSY					
PCB7	141 0 1939	06000 Touch Switch P.C.B. Assy	1				
	141 2 3529	44400 Spacer	1				
CN5	131 0 4006	22227 Cord Assy	1				
CN6	4 2359	77680 Connector 9P Assy	1				
CN7	131 0 4006	22215 Cord Assy	1				
SW1	4 2312	05801 Key Board Switch (1)	1				
SW2	4 2312	05801 Key Board Switch (2)	1				
SW3	4 2312	05801 Key Board Switch (3)	1				
SW4	4 2312	05801 Key Board Switch (4)	1				
SW5	4 2312	05801 Key Board Switch (5)	1				
SW6	4 2312	05801 Key Board Switch (6)	1				
SW7	4 2312	05801 Key Board Switch (7)	1				
SW8	4 2312	05801 Key Board Switch (8)	1				
SW9	4 2312	05801 Key Board Switch (9)	1				
SW10	4 2312	05801 Key Board Switch (CLR)	1				
SW11	4 2312	05801 Key Board Switch (INTRO)	1				
SW12	4 2312	05801 Key Board Switch (RPT)	1				
SW13	4 2312	05801 Key Board Switch (PLAY/REJ)	1				
D201	DYY - SLR-	54VT- LED, SLR 54 VT 3 (1)	1				
D202	DYY - SLR-	54VT- LED, SLR 54 VT 3 (2)	1				
D203	DYY - SLR-	54VT- LED, SLR 54 VT 3 (3)	1				
D204	DYY - SLR-	54VT- LED, SLR 54 VT 3 (4)	1				
D205	DYY - SLR-	54VT- LED, SLR 54 VT 3 (5)	1				
D206	DYY - SLR-	54VT- LED, SLR 54 VT 3 (6)	1				
D207	DYY - SLR-	54VT- LED, SLR 54 VT 3 (7)	1				
D208	DYY - SLR-	54VT- LED, SLR 54 VT 3 (8)	1				
D209	DYY - SLR-	54VT- LED, SLR 54 VT 3 (9)	1				
D210	DYY - SLR-	54VT- LED, SLR 54 VT 3 (INTRO)	1				
D211	DYY - SLR-	54PT- LED, SLR 54 PT 3 (RPT)	1				

LED P.C.BOARD (BOTTOM VIEW)

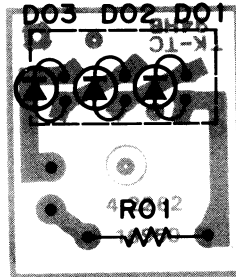

POWER SUPPLY P.C.BOARD (BOTTOM VIEW)

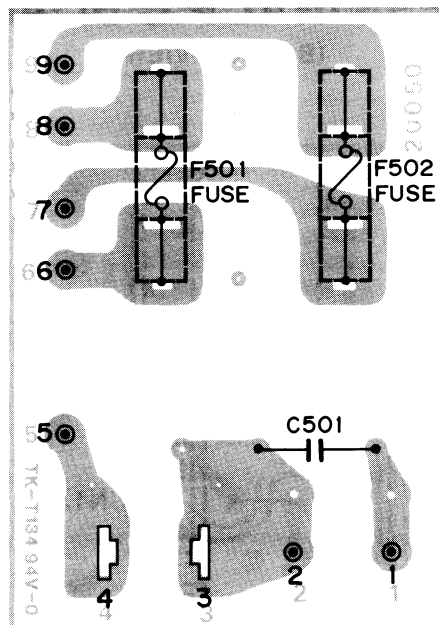

PTR P.C.BOARD
(BOTTOM VIEW)

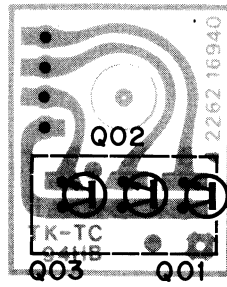

PCR P.C.BOARD
(BOTTOM VIEW)

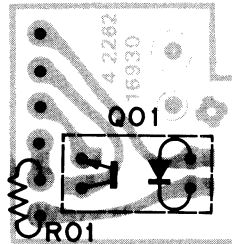

TERMINAL P.C.BOARD
(BOTTOM VIEW)

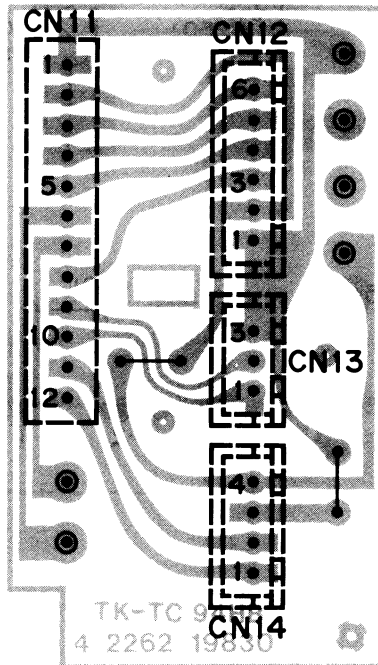

CONTROL P.C. BOARD (BOTTOM VIEW)

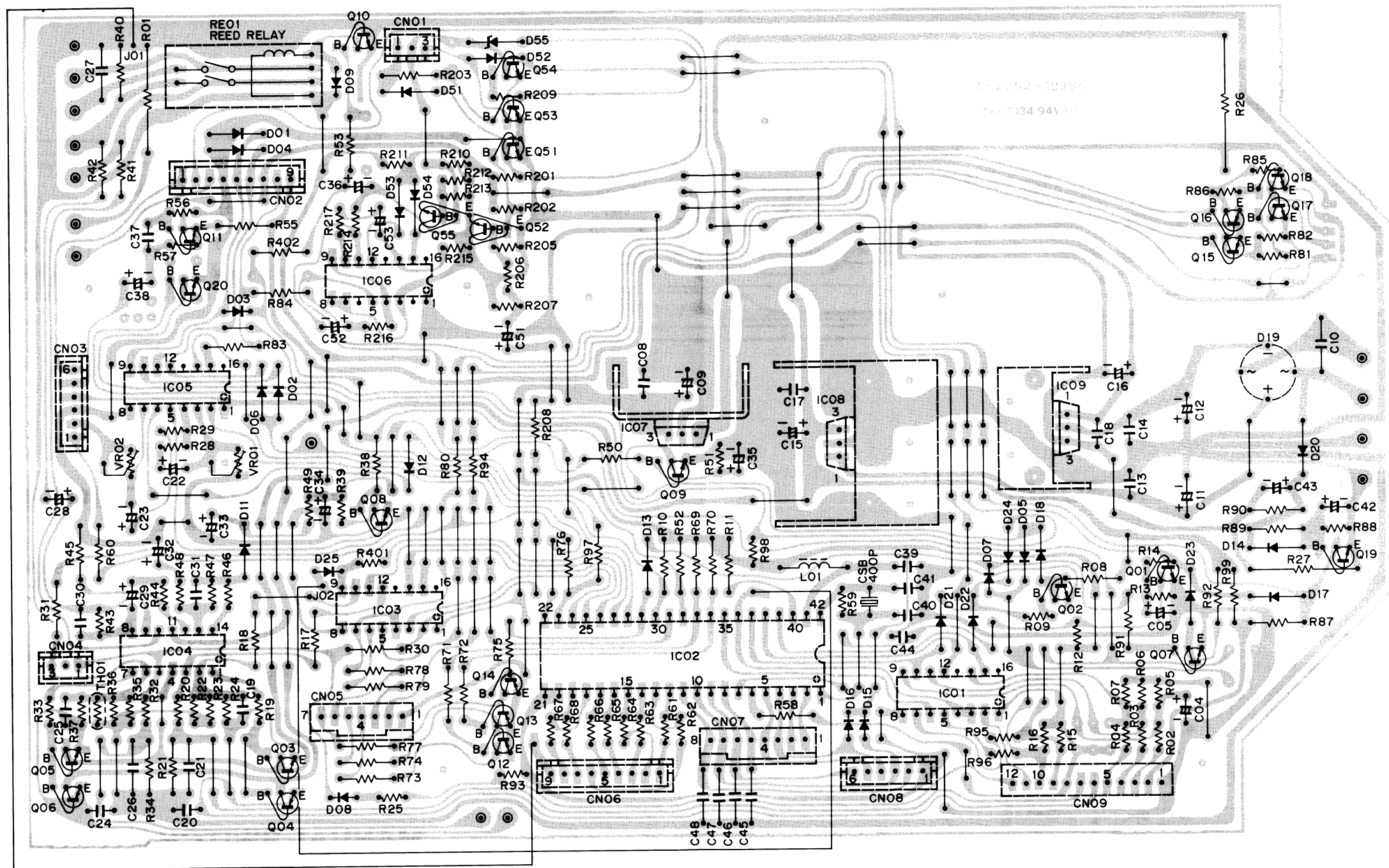

IC PIN NUMBERS DC VOLTAGES

SYMBOL No.	DEVICE	1	2	3	4	5	6	7	8	9	10	11	12	13	14	15	16	17	18	19	20
IC01	MSM4049	5.0V	0V	5.0V	5.0V	0V	0V	3.8V	0V	4.4V	0V	0V	5.0V	-	0V	5.0V	-				
IC03	MSM4049	5.0V	0V	5.0V	0V	4.7V	5.0V	0V	0V	5.0V	0V	5.0V	0V	-	5.0V	0V	-				
IC04	LA6324	0.6V	0V	0V	12.1V	0V	0V	-0.6V	0V	10V	-12.3V	0V	0V	0V	0V	0V	-				
IC05	MSM4049	5.0V	5.0V	0V	0V	5.0V	5.0V	0V	0V	-0.6V	5.0V	5.0V	0V	-	5.0V	0V	-				
IC06	MSM4049	5.0V	-	-	0V	5.0V	-	-	0V	0V	5.0V	0V	5.0V	-	0V	5.0V	-				
IC07	L78M05	10.2V	0V	5.0V																	
IC08	NJM7812	19.2V	0V	12.1V																	
IC09	NJM7912	0V	-19.8V	-12.3V																	
IC02	LM6402A	1.6V	4.2V	4.1V	4.1V	4.2V	5.0V	5.0V	5.0V	5.0V	4.9V	5.0V	3.7V	3.7V	3.7V	3.7V	3.7V	3.7V	3.7V	3.7V	0V
		21	22	23	24	25	26	27	28	29	30	31	32	33	34	35	36	37	38	39	40
		0V	5.0V	4.7V	5.0V	5.0V	5.0V	5.0V	5.0V	4.9V	5.0V	5.0V	5.0V	5.0V	5.0V	0V	5.0V	0V	5.0V	5.0V	5.0V
		41	42																		
		5.0V	2.2V																		

TRANSISTOR DC VOLTAGES

SYMBOL No.	DEVICE	B	C	E	SYMBOL No.	DEVICE	B	C	E	SYMBOL No.	DEVICE	B	C	E
Q01	2SC536	0V	5.0V	0V	Q08	2SC536	0.6V	0V	0V	Q17,18	2SC536	-11.6V	-12.3V	-12.3V
Q02	2SC536	0.7V	0.1V	0V	Q09	2SC536	0V	5.0V	0V	Q19	2SC536	0.6V	0V	0V
Q03	2SD863	0.6V	12.1V	0V	Q10	2SC536	0.8V	0.2V	0V	Q51	2SC536	0.7V	0V	0V
Q04	2SB764	0.6V	-12.3V	0V	Q11	2SC536	-0.9V	12.1V	-1.5V	Q52	2SC536	0V	0.7V	0V
Q05	2SD863	-0.6V	12.1V	0.1V	Q12,13	2SA608	5.0V	0V	5.0V	Q53	2SC536	0.1V	-0.1V	0V
Q06	2SB764	-0.6V	-12.3V	0.1V	Q14	2SA608	4.9V	0V	5.0V	Q54	2SC536	0V	0.1V	0V
Q07	2SC536	0.7V	0V	0V	Q15,16	2SA608	4.3V	5.0V	5.0V	Q55	2SC536	0.7V	0.1V	0V

TOUCH SWITCH P.C.BOARD (BOTTOM VIEW)

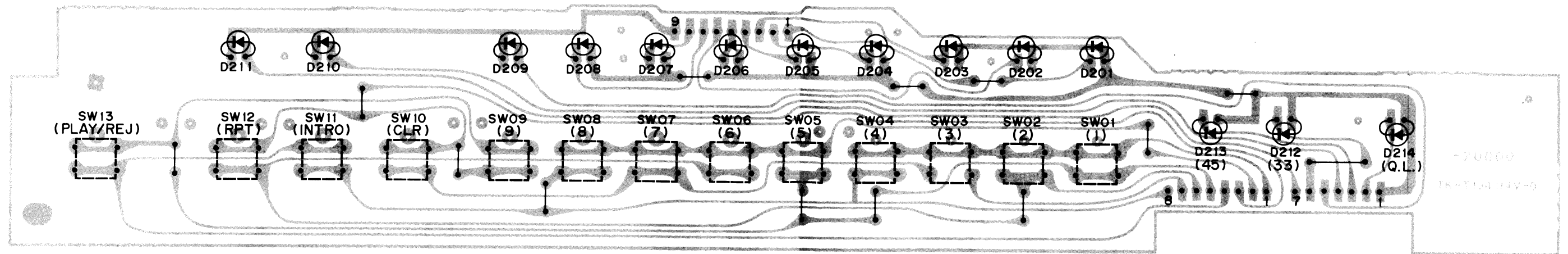

SUB CONTROL P.C.BOARD (BOTTOM VIEW)

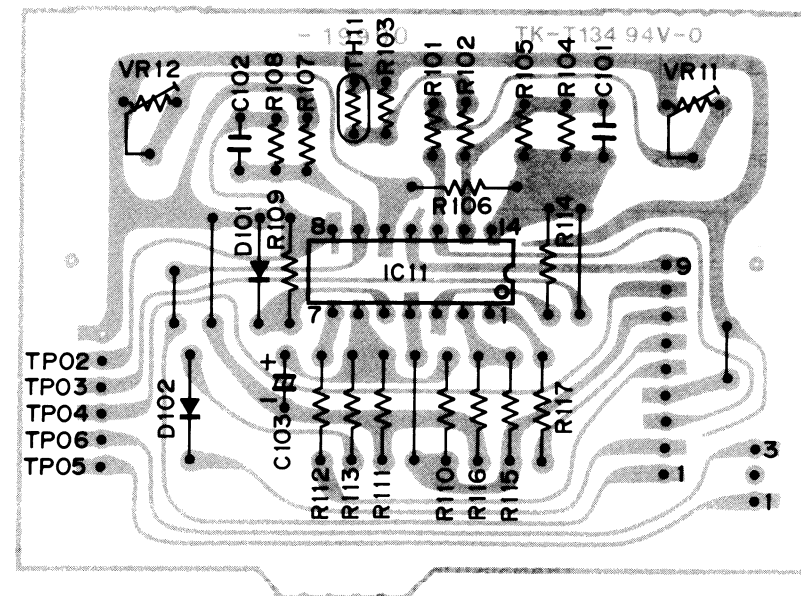

SLIDE SWITCH P.C.BOARD (BOTTOM VIEW)

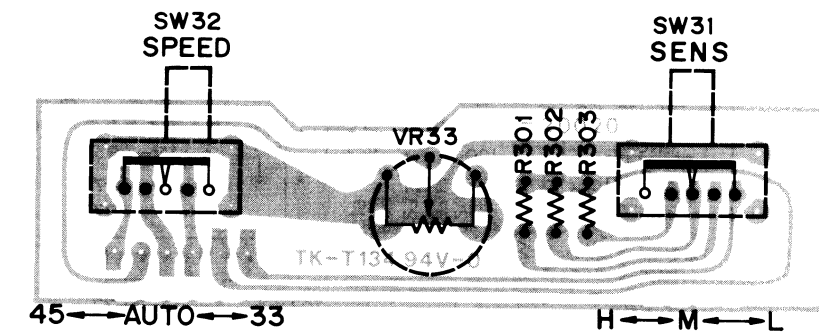

MANUAL SWITCH P.C.BOARD (BOTTOM VIEW)

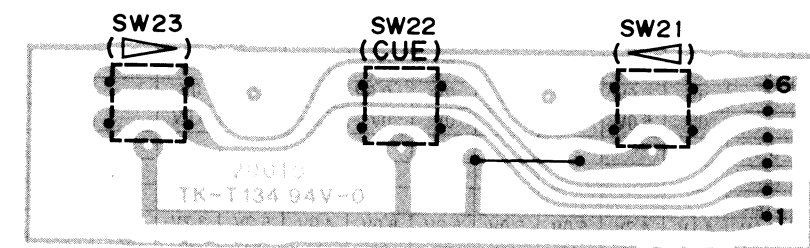

		IC PIN NUMBERS DC VOLTAGES													
SYMBOL No.	DEVICE	1	2	3	4	5	6	7	8	9	10	11	12	13	14
IC11	LA6324	-11.7V	1.7V	0V	12.1V	0.1V	4.9V	0.1V	0.1V	0V	0V	-12.3V	0V	0V	0V

SCHEMATIC DIAGRAM

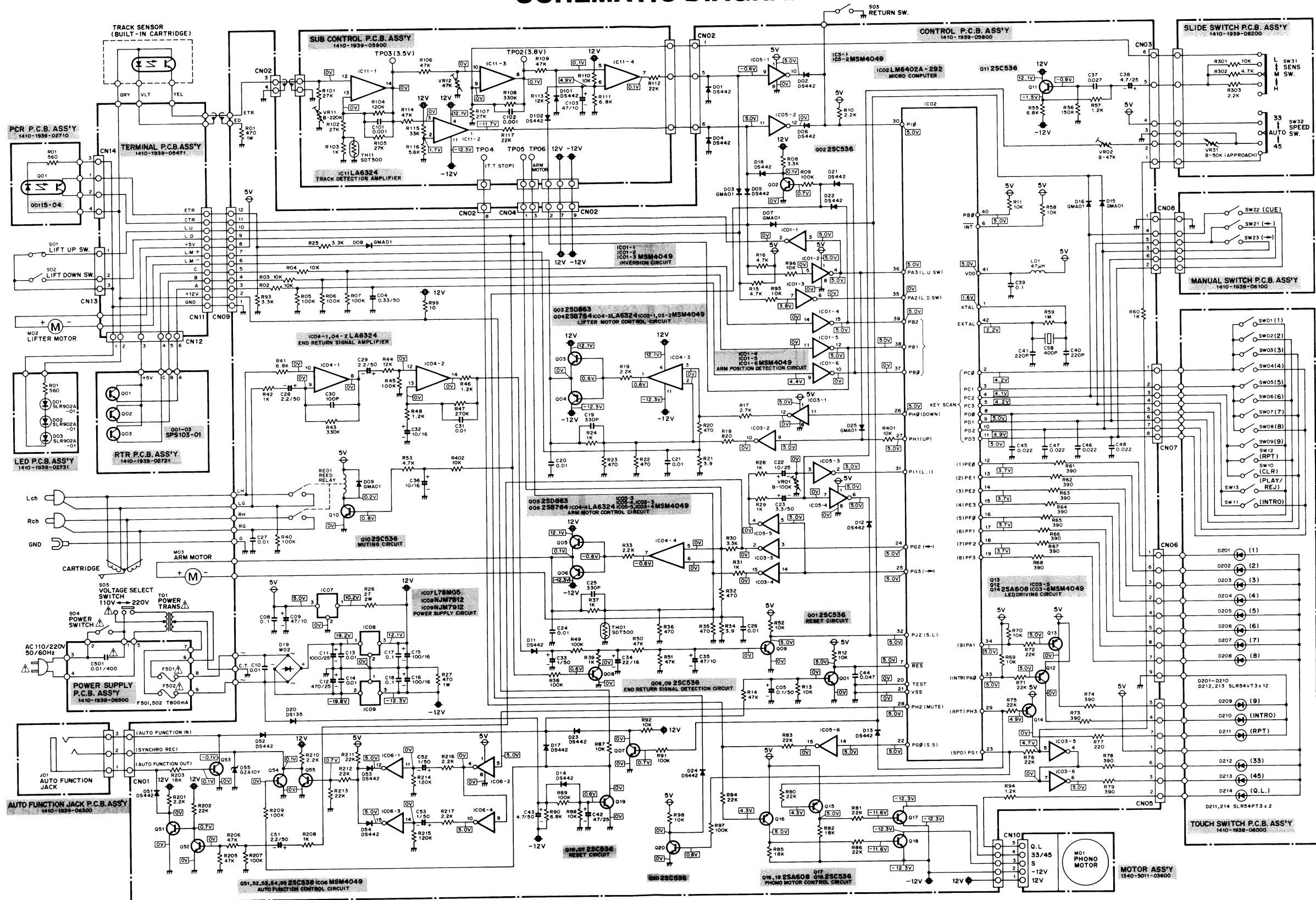

PRODUCT SAFETY NOTICE

Each precaution in this manual should be followed during servicing. Components identified with the IEC symbol in the parts list and the schematic diagram designate components in which safety can be of special significance. When replacing a component identified with , use only the replacement parts designated, or parts with the same ratings of resistance, wattage or voltage that are designated in the parts list in this manual. Leakage-current or resistance measurements must be made to determine that exposed parts are acceptably insulated from the supply circuit before returning the product to the customer.

No.	Name	Position	No.	Name	Position
SW1	(1) Switch	OFF	SW13	PLAY/REJ Switch	OFF
SW2	(2) Switch	OFF	SW21	(<) Switch	OFF
SW3	(3) Switch	OFF	SW22	CUE Switch	OFF
SW4	(4) Switch	OFF	SW23	(>) Switch	OFF
SW5	(5) Switch	OFF	SW31	SENS Switch	M
SW6	(6) Switch	OFF	SW32	SPEED Switch	AUTO
SW7	(7) Switch	OFF			
SW8	(8) Switch	OFF	S1	LIFT UP Switch	ON
SW9	(9) Switch	OFF	S2	LIFT DOWN Switch	OFF
SW10	CLEAR Switch	OFF	S3	RETURN Switch	M
SW11	INTRO Switch	OFF	S4	POWER Switch	OFF
SW12	REPEAT Switch	OFF	S5	VOLTAGE SELECT Switch	220V

NOTES:

- All resistors values are indicated in "ohm" (K=10³, M=10⁶).
 - All capacitors values are indicated in "μF" (P=10⁻¹²).
 - All voltages indicated on the schematics are measured under the following conditions.
 - Use a V.T.V.M.
 - This is a basic schematic diagram.
- Because Fisher products are subject to continuous improvement, Fisher Corporation reserves the right to make any changes or modifications without notice.

POINT TO POINT WIRING DIAGRAM

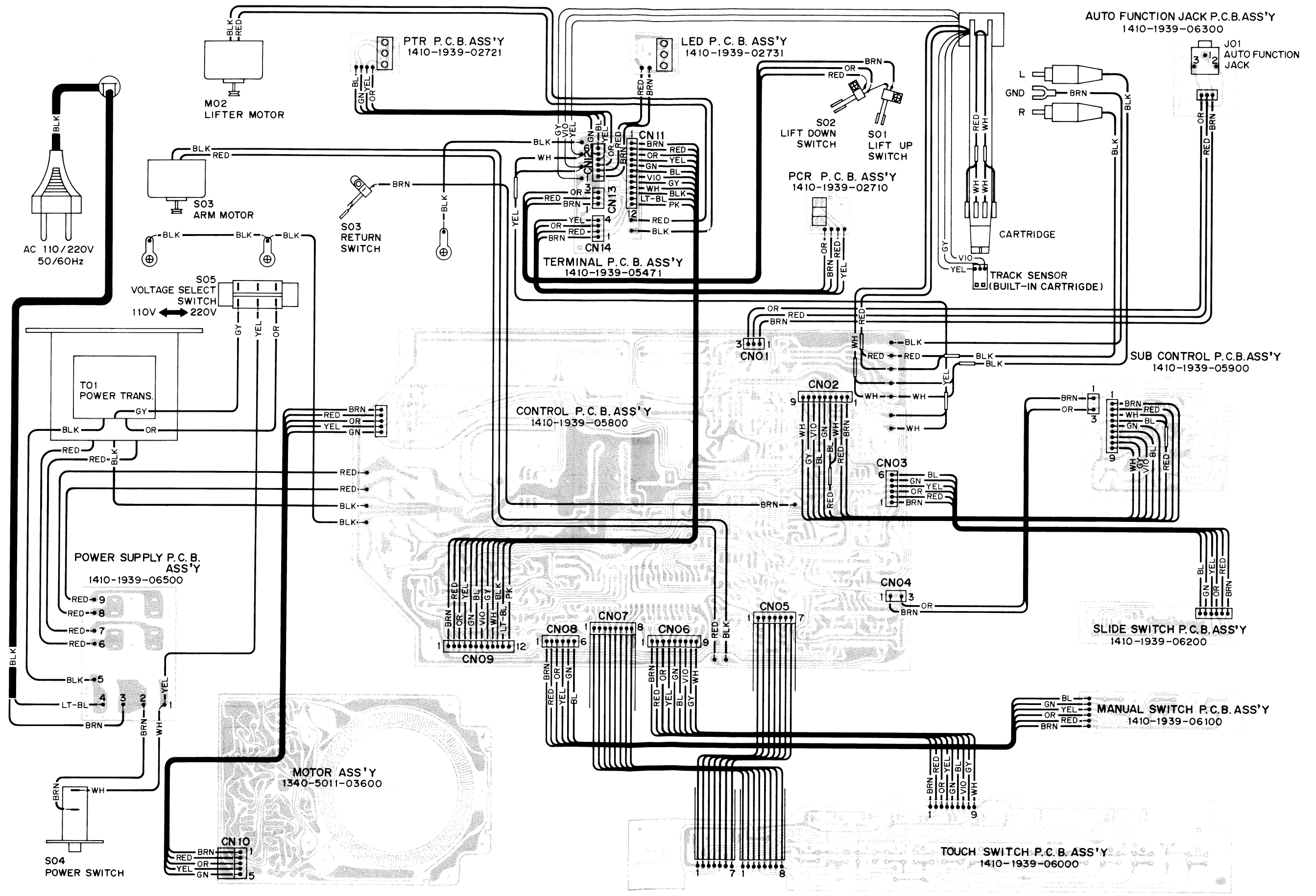

MOTOR ASSY SCHEMATIC DIAGRAM

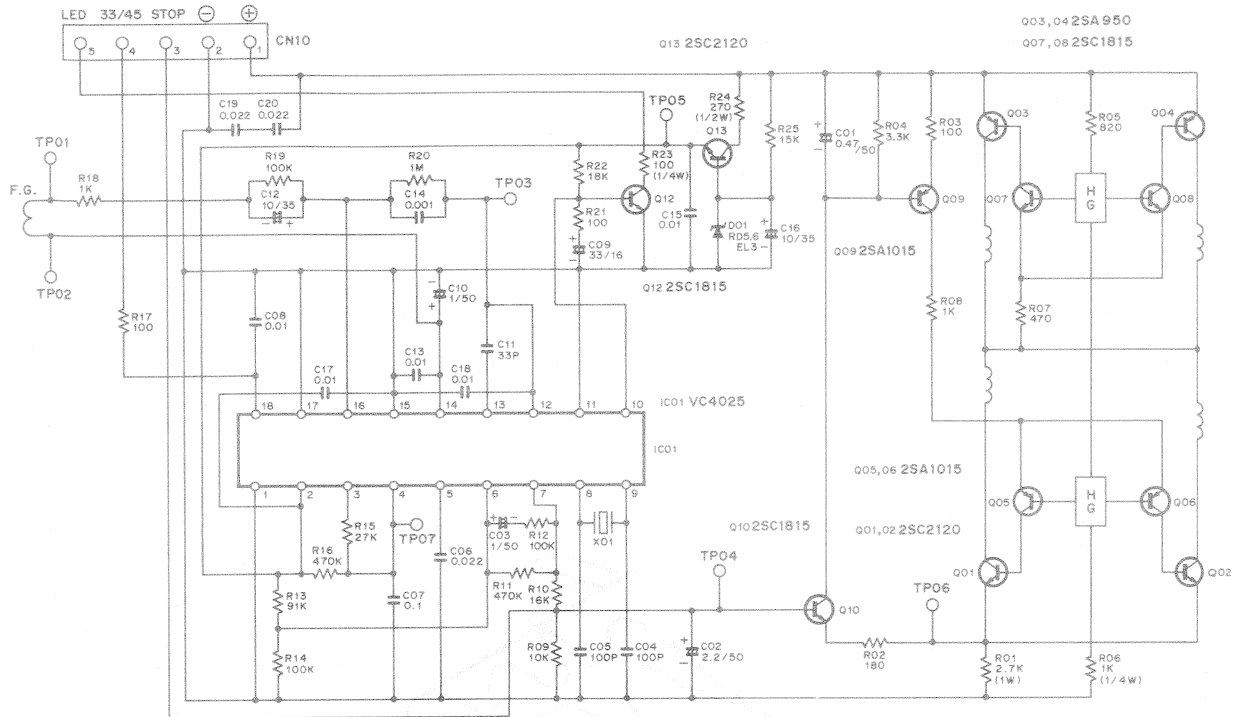

MOTOR ASSY P.C.BOARD (BOTTOM VIEW)

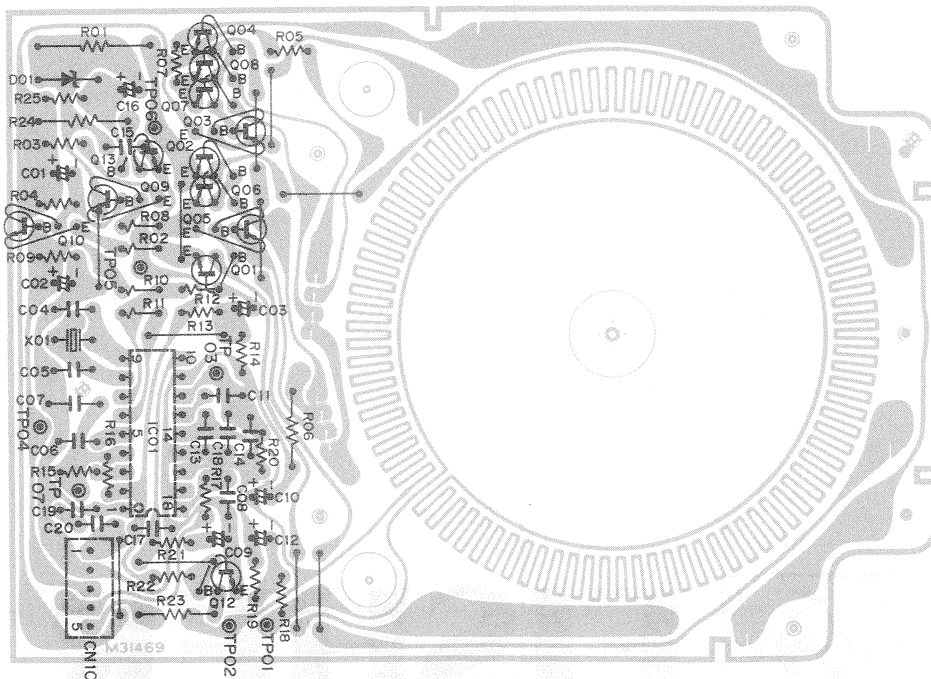

CAUTION

Should the Servo motor, control P.C.B. assembly or any of the transistors, diodes, volume controls, resistors, capacitors, etc. installed on the control P.C.B. assembly develop trouble, do not replace only the faulty parts but the motor and the control P.C.B. assembly as well.

This is necessary because the control P.C.B. assembly is finely adjusted to match the performance characteristics of the motor. If only the faulty parts have been replaced, we shall not be held responsible for deterioration in the performance of the unit.