



FISH -00849

SERVICE MANUAL



FISHER

MT-M22

**Stereo Turntable
(EUROPE)**



134 082 40
(Silver)
134 082 41
(Red)
134 082 42
(Black)

WM-14441

CONTENTS

Arm Feed Cord Stringing	2
Specifications	3
Cabinet & Chassis Exploded View	4,5
Cabinet & Chassis Parts List	6,7
IC Signal Flow & Equivalent Circuit	8
Turntable Adjustments	9,10
Printed Circuit Board (Bottom View)	11,12,13,14
P.C.Board Parts List	15,16
Schematic Diagram	17,18
Point to Point Wiring Diagram	19,20
Semiconductor Lead Identification	21

ARM FEED CORD STRINGING

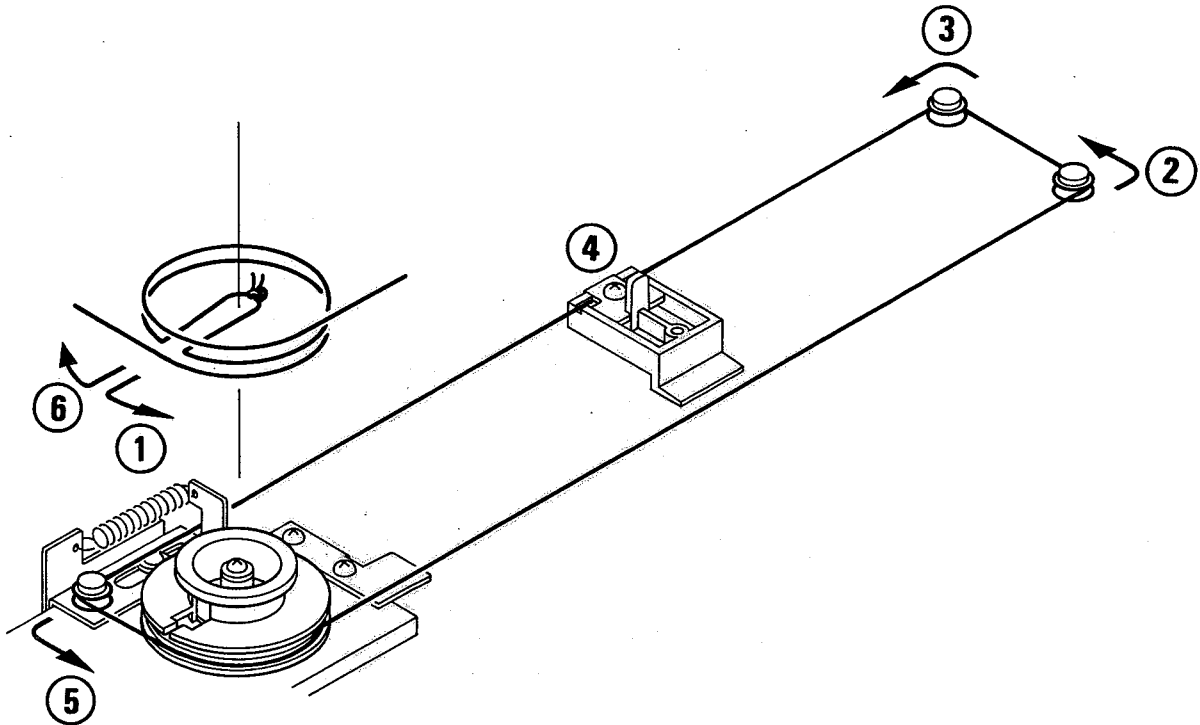

SPECIFICATIONS

TURNTABLE	MT-M22
Motor	DC Servo
Drive System	Belt
Wow and Flutter (WRMS)	0.08 %
Rumble (DIN B)	-65 dB
Speed Variation	±1.5 %
Tracking Force	2 g
Platter Diameter	300 mm
Platter Weight	0.4 kg
Record Speed Selector	33-1/3 rpm/ 45 rpm
Operation	Full Auto Linear Tracking
GENERAL	
Dimensions (W x H x D)	335 x 93 x 335 mm
Weight (approx.)	3 kg

Because its products are subject to continuous improvement, Fisher Corporation reserves the right to modify product designs and specifications without notice and without incurring any obligation.

CABINET & CHASSIS EXPLODED VIEW

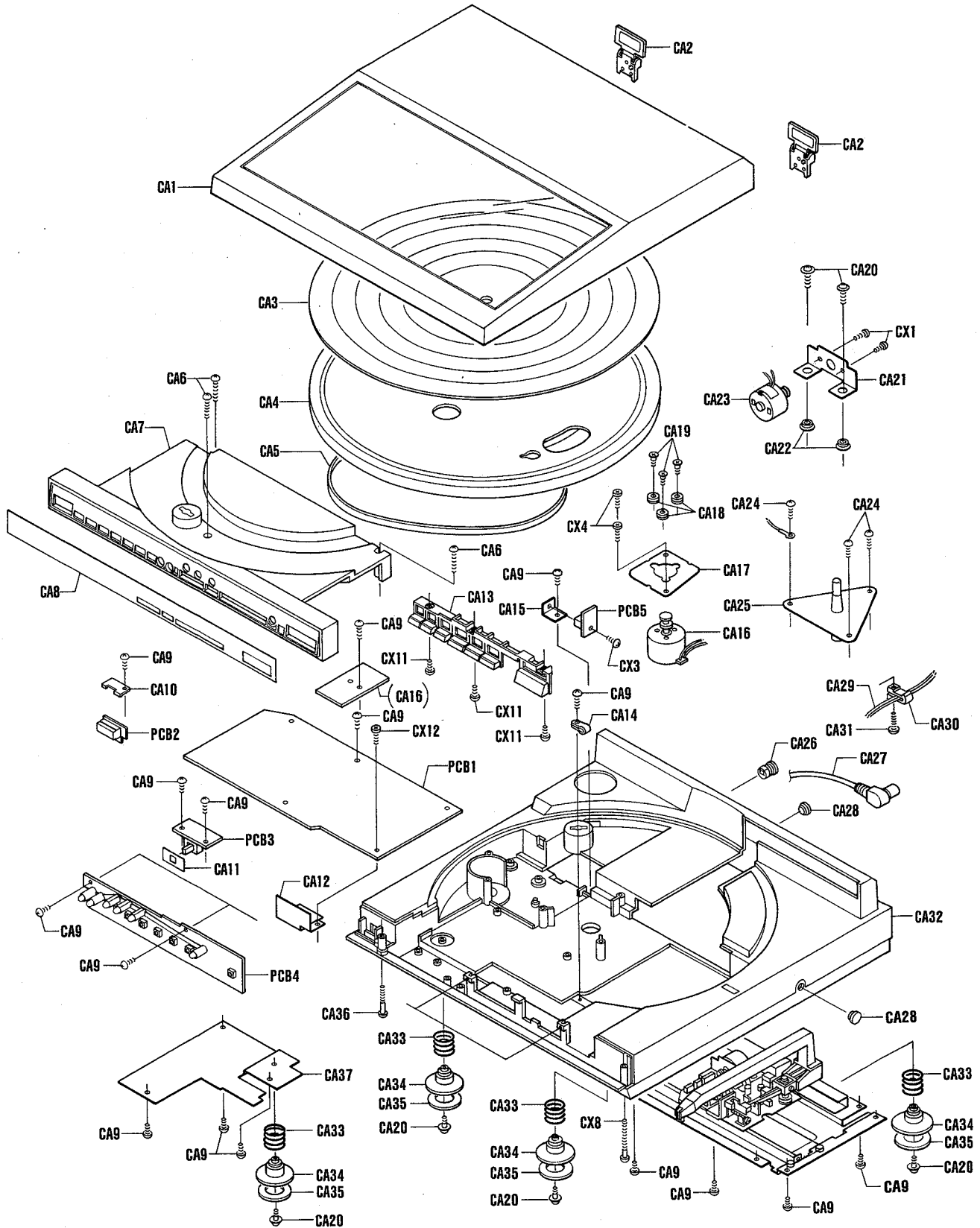

CABINET & CHASSIS EXPLODED VIEW (Continued)

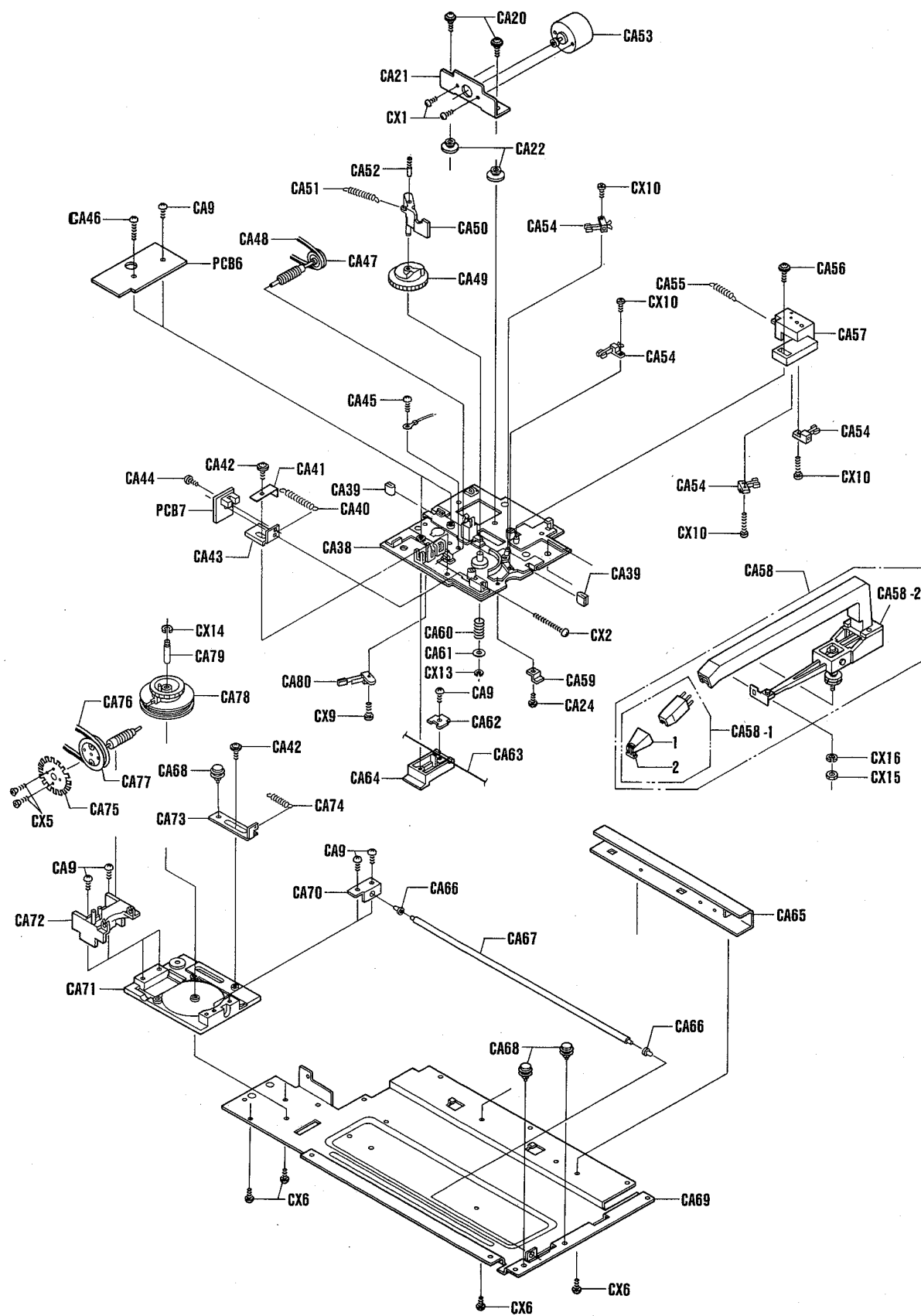

CABINET & CHASSIS PARTS LIST

Ref. No.	Part No.	Description	Q'ty	Ref. No.	Part No.	Description	Q'ty
PACKAGE							
	131-6-2119-02081	Bag Polyethylene-exp	1	CA21	141-2-3519-67100	Angle Mount(Motor)	2
	131-6-3069-17050	Patching Sheet	1	CA22	141-2-4459-31800	Cushion	4
	131-6-9439-00400	Ribbon	2	CA23	4-5272-00181	Comutate Motor Magnet (Arm) [M3]	1
	141-2-4219-32700	Screw Transit	1	CA24	131-2-4201-19502	Screw, Button Hd. Tapping-3	4
	141-6-2519-20990	Bag Polyethylene-exp	1	CA25	141-0-7519-03900	Shaft Turntable Complet	1
	141-6-3119-23100	Pad Front	1	CA26	131-2-6111-14700	Bushing	1
	141-6-3119-23200	Pad Rear	1	CA27	4-2369-74240	Plug Cord Din8p L	1
	141-6-3119-23401	Pad	1	CA28	131-2-2904-11001	Pad Lid (Silver)	2
	141-6-3119-23500	Pad	1	CA28	131-2-2904-11000	Pad Lid (Red/Black)	2
	141-6-3119-25600	Pad	1	CA29	4-2369-74062	Plug Cord	1
	141-6-3319-13200	Spacer	3	CA30	131-2-3608-11000	Cramp Wire	1
	141-6-1139-95014	Box Corrugate-exp (Silver)	1	CA31	131-2-4201-25203	Screw, Brazier Hd. Tapping, +M3.0x16	1
	141-6-1139-95015	Box Corrugate-exp (Red)	1	CA32	141-2-1119-99700	Cabinet (Silver)	1
	141-6-1139-95016	Box Corrugate-exp (Black)	1	CA32	141-2-1119-99701	Cabinet (Red)	1
	141-6-4559-03300	Serial No. Sheet	2	CA32	141-2-1119-99704	Cabinet (Black)	1
ACCESSORIES							
	131-6-2719-10401	Bag Fan	1	CA33	141-2-8559-06500	Spring Mounting	4
	131-6-4519-15700	Guarantee Cert	1	CA34	141-2-4459-31700	Cushion(Leg)	4
	131-6-4559-10900	Manufacturing No.	1	CA35	131-2-5203-23603	Felt	4
	134-2-2901-11601	Adapter EP	1	CA36	141-2-4219-09601	Screw	1
	142-6-4119-32412	Explanatory Booklet	1	CA37	141-2-1149-35000	Cover	1
CABINET							
	4-2359-76479	Connector 5P Assy [CN2]	1	CA38	141-0-3129-01900	Unit Plate Assy	1
	4-2359-76794	Connector 3P Assy [CN4]	1	CA39	141-2-4459-33800	Cushion	2
	4-2359-77145	Connector 1P Assy (TML P.C.B)	1	CA40	141-2-8519-31900	Spring Slide Base	1
	4-2359-78077	Connector 1P Assy (CONT P.C.B.)	1	CA41	141-2-8539-53800	Spring Plate	1
	4-2359-78400	Connector 4P Assy [CN3]	1	CA42	131-2-4201-21100	Screw	2
	131-2-1310-30750	Name Plate	1	CA43	141-2-3519-67400	Angle Mount(Photo C)	1
	131-2-3608-14100	Cramp Wire	3	CA44	131-2-4201-20800	Screw, M2.6x6	1
	141-2-1449-62900	Label	1	CA45	131-2-4201-19500	Screw, Button Hd. Tapping-3	1
	134-6-4739-13403	Stylus Label	1	CA46	131-2-4201-19504	Screw, Button Hd. Tapping-3	1
	141-6-4559-03300	Serial No. Sheet	1	CA47	141-0-5519-10300	Worm Assy	1
	141-6-4729-37623	Caution Label	1	CA48	141-2-5649-25900	Belt	1
CA1	141-0-1249-30505	Lid Assy (Silver)	1	CA49	141-2-5519-52100	Worm Wheel(A)	1
CA1	141-0-1249-30506	Lid Assy (Red)	1	CA50	141-2-7519-64000	Spindle Lifting	1
CA1	141-0-1249-30509	Lid Assy (Black)	1	CA51	141-2-8519-60000	Spring Plate	1
CA2	131-0-2002-16801	Hinge Assy	2	CA52	134-2-4201-12800	Screw	1
CA3	134-2-6102-15702	Mat Turntable	1	CA53	4-5272-00180	Comutate Motor Magnet (Lifter) [M2]	1
CA4	141-2-5229-00200	Turntable	1	CA54	4-2319-76680	Leaf Switch (Lift Down) [SW9]	1
CA5	134-2-6302-11501	Belt	1	CA54	4-2319-76680	Leaf Switch (Lift Up) [SW10]	1
CA6	131-2-4201-19507	Screw, Button Hd. Tapping-3	3	CA54	4-2319-76680	Leaf Switch (T58) [SW12]	1
CA7	141-2-1219-31300	Panel Front (Silver)	1	CA54	4-2319-76680	Leaf Switch (Right End) [SW13]	1
CA7	141-2-1219-31301	Panel Front (Red)	1	CA55	134-2-5101-32400	Spring	1
CA7	141-2-1219-31303	Panel Front (Black)	1	CA56	141-2-4219-06300	Screw	1
CA8	141-2-1439-14903	Panel Control (Silver)	1	CA57	141-2-3519-73000	Holder	1
CA8	141-2-1439-14906	Panel Control (Red)	1	CA58	141-0-6419-00503	Pick-up Assy (Silver)	1
CA8	141-2-1439-14902	Panel Control (Black)	1	CA58-1	4-1579-27031	Cartridge(MG-37L)	1
CA9	131-2-4201-19501	Screw, Button Hd. Tapping-3	26	1	4-1579-29451	Stylus(ST-37LD)	1
CA10	141-2-3519-72800	Angle Mount	1	2	134-2-1402-12700	Retainer Needle	1
CA11	141-2-4419-21100	Cloth	1	CA58-2	141-0-6419-00803	Tone Arm Assy	1
CA12	141-2-3229-52600	Cover Shield	1	CA58	141-0-6419-00502	Pick-up Assy (Red/Black)	1
CA13	141-2-1659-40700	Knob	1	CA58-1	4-1579-27031	Cartridge(MG-37L)	1
CA14	131-2-3608-12405	Cramp Wire	1	1	4-1579-29451	Stylus(ST-37LD)	1
CA15	141-2-3519-73400	Angle Mount	1	2	134-2-1402-12700	Retainer Needle	1
CA16	134-0-5011-03502	Motor Assy [M1]	1	CA58-2	141-0-6419-00803	Tone Arm Assy	1
CA17	141-2-3169-23300	Metal Mount Motor	1	CA59	134-2-4108-27801	Plate	1
CA18	134-2-5202-11800	Rubber Cushion	3	CA60	134-2-5101-26500	Spring	1
CA19	134-2-4201-13600	Screw	3	CA61	141-2-4579-05000	Washer, M3.2x10x0.2	1
CA20	134-2-4201-13400	Screw	8	CA62	141-2-3519-70300	Angle Mount	1
				CA63	131-2-4112-10200	Rope	1
				CA64	141-2-7319-58000	Holder Slide	1
				CA65	141-2-3169-25400	Guide Angle	1
				CA66	141-2-4459-33200	Cushion	2
				CA67	141-2-5289-01300	Rail	1
				CA68	131-0-3020-11800	Pulley Assy	3
				CA69	141-2-1259-06201	Plate Bottom	1

CABINET & CHASSIS PARTS LIST (Continued)

Ref. No.	Part No.	Description	Q'ty
CA70	141-2-3519-69100	Angle Mount(Rail)	1
CA71	141-2-3169-23200	Frame	1
CA72	141-2-5739-07300	Support Shaft	1
CA73	141-2-3519-69000	Angle Mount	1
CA74	141-2-8519-35300	Spring Base Slide	1
CA75	141-2-3519-73300	Plate	1
CA76	141-2-5649-25800	Belt	1
CA77	141-0-5519-10301	Worm Assy	1
CA78	141-2-5519-60100	Worm Wheel(C)	1
CA79	141-2-5529-18900	Shaft	1
CA80	4-2319-77560	Leaf Switch (Left End) [SW11]	1
CX1	101-3-1302-00311	Screw, Pan Hd., +M2.0x3	4
CX2	101-3-1303-03011	Screw, Pan Hd., +M3.0x30	1
CX3	101-3-1702-60411	Screw, Bind Hd., +M2.6x4	1
CX4	102-3-1703-00811	Screw, Bind Hd. Tapping-1, +M3.0x8	2
CX5	103-3-1202-00518	Screw, Flat Hd. Tapping-2, +M2.0x5	2
CX6	103-3-1303-00511	Screw, Pan Hd. Tapping-2, +M3.0x5	2
CX7	131-3-1302-31011	Screw, Pan Hd. C SW, +M2.3x10	1
CX8	143-3-1303-02511	Screw, Pan Hd. Tapping-B, +M3.0x25	1
CX9	143-3-1702-00618	Screw, Bind Hd. Tapping-B, +M2.0x6	1
CX10	143-3-1702-00818	Screw, Bind Hd. Tapping-B, +M2.0x8	4
CX11	143-3-1902-60611	Screw, Brazier Hd. Tapping-B, +M2.6x6	3
CX12	143-3-1903-00811	Screw, Brazier Hd. Tapping-B, +M3.0x8	1
CX13	112-3-1302-00011	E Ring, M2.0	1
CX14	112-3-1303-00011	E Ring, M3.0	1
CX15	106-3-1204-00311	Hex. Nut-2, M4.0	1
CX16	110-3-2104-00011	Spring Washer-2, M4.0	1
PCB1	141-0-1939-10031	Control P.C.B. Assy	1
PCB2	141-0-1939-10040	Power Indicator P.C.B. Assy	1
PCB3	141-0-1939-10050	Speed P.C.B. Assy	1
PCB4	141-0-1939-10060	Switch P.C.B. Assy	1
PCB5	141-0-1939-10070	PIR P.C.B. Assy	1
PCB6	141-0-1939-10080	Terminal P.C.B. Assy	1
PCB7	141-0-1939-10090	PCR P.C.B. Assy	1

NOTES:

1. Parts order must contain Model Number, Part Number and Description.
2. Ordering quantity of screws and resistors must be multiple of 10 pcs.

IC SIGNAL FLOW & EQUIVALENT CIRCUIT

CONTROL IC LM 6416 E

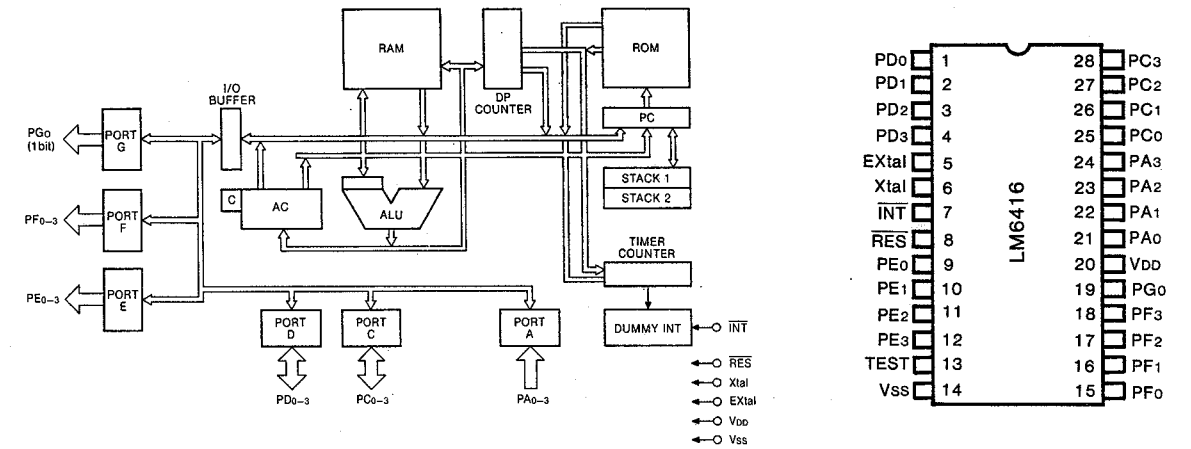

VOLTAGE REGULATOR IC NJM 7812

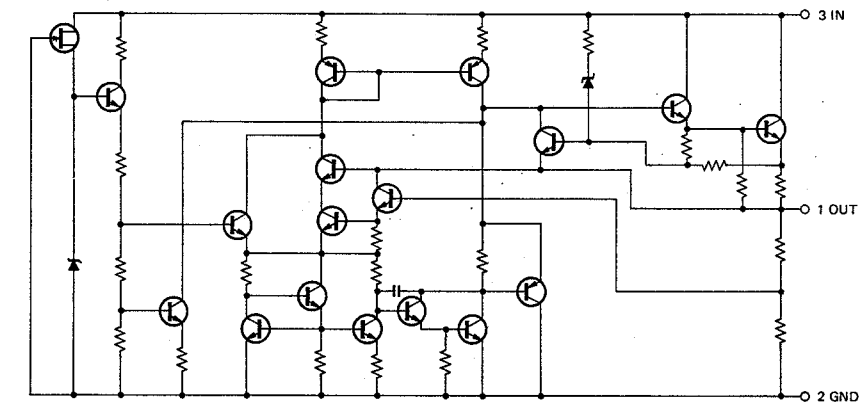

VOLTAGE REGULATOR IC NJM 7912

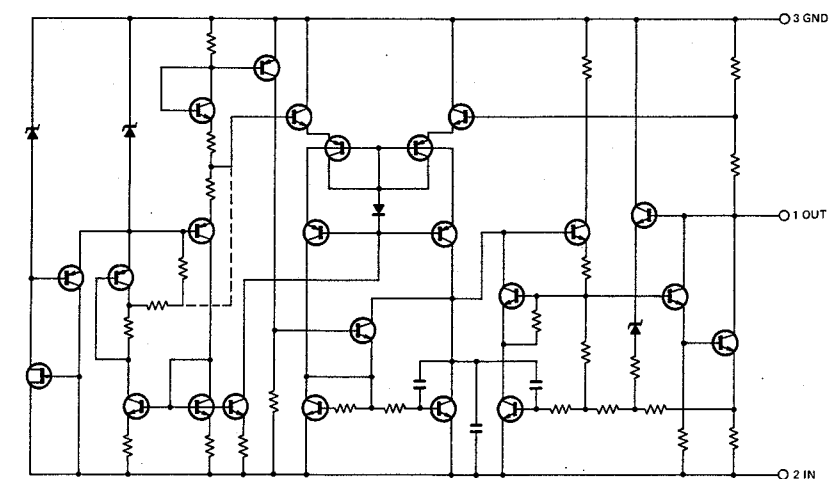

TURNTABLE ADJUSTMENTS

Stylus Pressure Adjustment

1. Place the unit on a horizontal plane and remove the lid.
2. Turn on the Power switch of the unit.
3. Press ◀ button on the control panel to shift the tonearm to the place as indicated in Fig. 1.
4. Turn the stylus pressure adjustment screw as shown in Fig. 2 through the stylus pressure adjustment hole, so that the stylus pressure meter indicates 1.8 ~ 2.2 g.

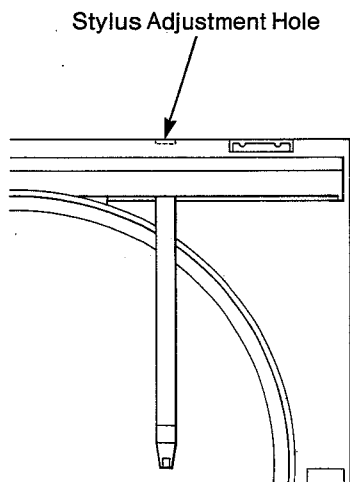

Fig. 1

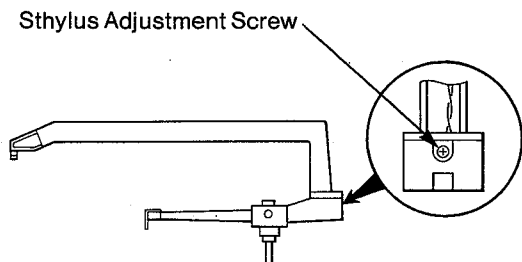

Fig. 2

Tonearm Position Adjustment

1. Turn on the power switch of the unit.
2. Remove the lid and the turntable.
3. Press ◀ button on the control panel to shift the arm to the place where the tonearm position adjustment cam can be observed. (Fig. 3)
4. Adjust the cam, so that the tonearm becomes perpendicular to the rear wall of the cabinet. (Fig. 3)

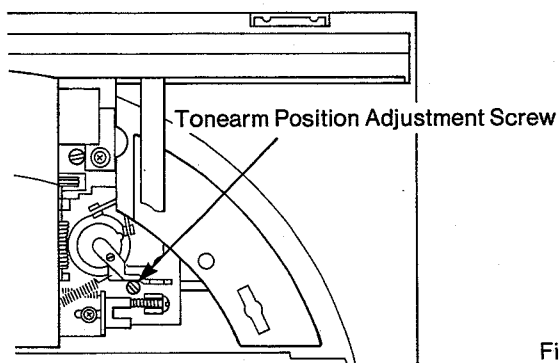

Fig. 3

Stylus Height Adjustment

1. Turn on the power switch of the unit.
2. Remove the lid and the turntable.
3. Press ◀ button on the control panel to shift the arm to the place where the stylus height adjustment screw can be observed. (Fig. 4)
4. Adjust the stylus height to 6mm±0.5mm above the turntable.

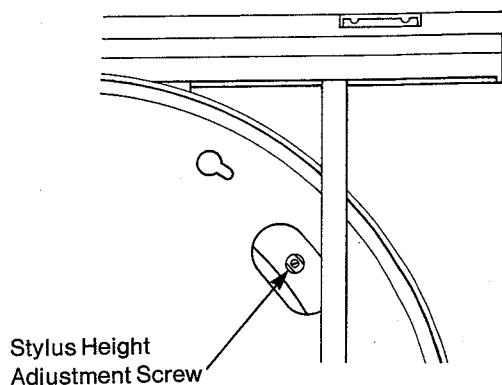

Fig. 4

Rotation Adjustment

1. Turn on the power switch of the unit.
 2. Use the stroboscope sheet and adjust each volume to obtain proper rotations per minute. (Fig. 5)
- Note: In the first instance, perform the adjustment for 45 r.p.m.

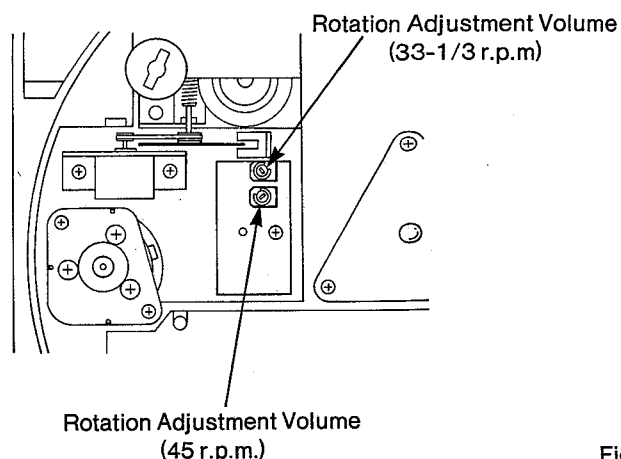

Fig. 5

TURNTABLE ADJUSTMENTS (Continued)

Photointerrupter Position Adjustment for Arm Feed

1. Turn on the power switch of the unit.
2. Place a record with less eccentricity on the turntable and play it.
3. After the record has rotated three or four times, raise the arm by pressing the CUEING button.
4. Turn the arm feed adjustment screw with a screwdriver through the hole on the right side of the cabinet, so that the arm rises straight up. (Fig. 6)

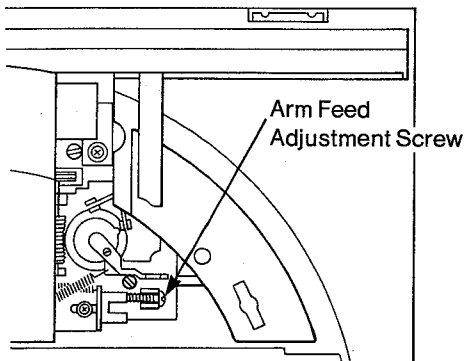

Fig. 6

Lead-in Position Adjustment

1. Turn on the power switch of the unit.
2. Place a record on the turntable and perform the lead-in operation.
3. Adjust the lead-in position adjustment cam, so that the record is led into the correct position.

Note: If the cam is turned clockwise, the tonearm moves inward. It moves outward if the cam is turned counter-clockwise. (Fig. 7)

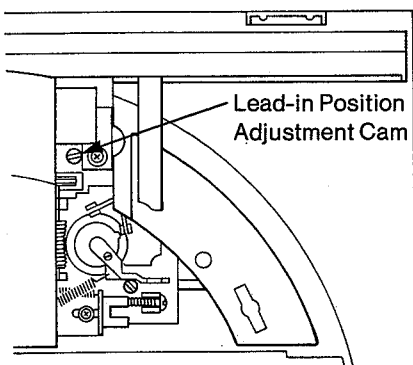
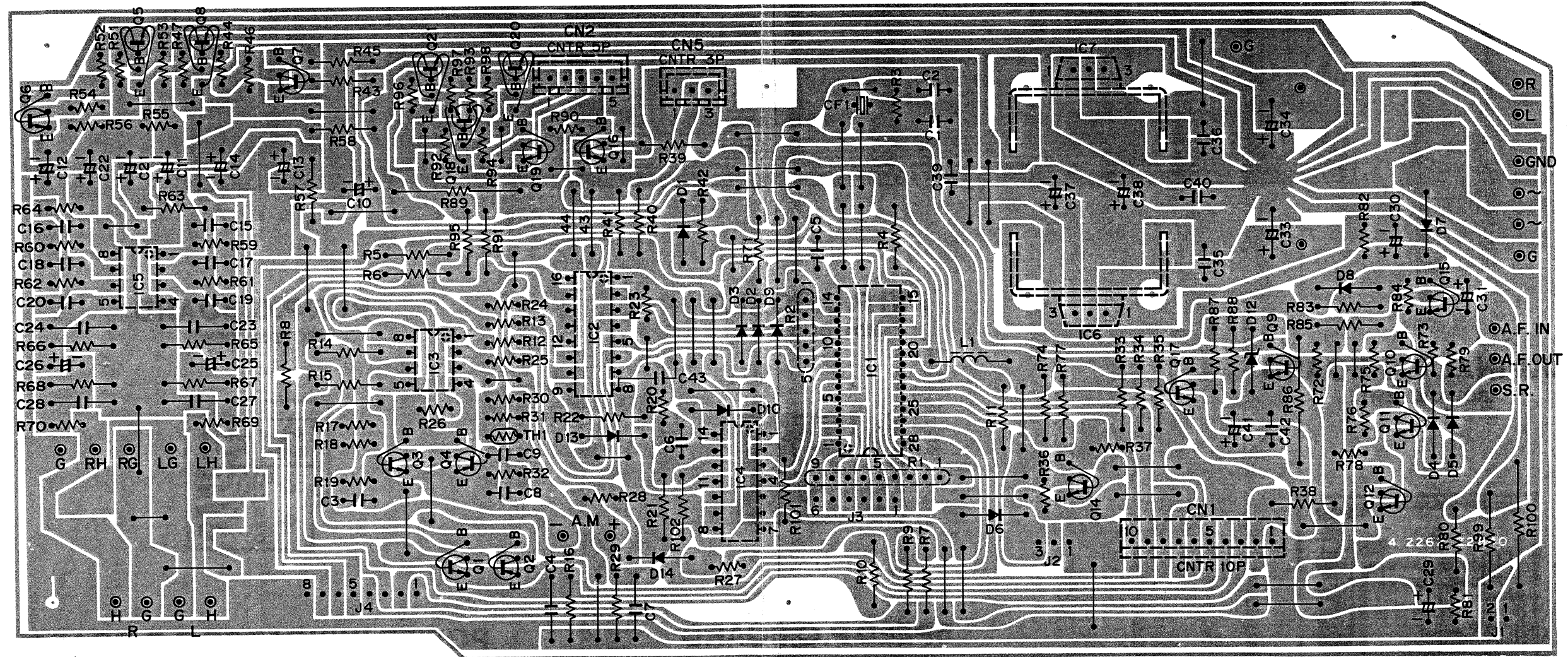

Fig. 7

CONTROL P.C. BOARD

(BOTTOM VIEW)



IC PIN NUMBERS DC VOLTAGES																					
SYMBOL No.	DEVICE	1	2	3	4	5	6	7	8	9	10	11	12	13	14	15	16	17	18	19	20
IC2	MSM4049RS	5.2V	0V	5.2V	0V	5V	0V	5V	0V	5.2V	0V	5.2V	0.5V	-	0.5V	5.1V	-				
IC3	M5218P	-0.5V	0V	0V	-12V	0V	0V	-0.6V	11.9V												
IC4	LC4011B	5.2V	0V	5.2V	5.2V	0V	0V	0V	5.2V	5.2V	0V	5.2V	4.6V	0V	5.2V						
IC5	M5218P	0V	0V	0V	-8.5V	0V	0V	0V	8.2V												
IC1	LM6416E	5.2V	5.2V	5.2V	5.2V	2.5V	2V	5.2V	5.2V	5V	5V	5.2V	5.2V	0V	0V	4.7V	4.2V	4.2V	3.2V	5.2V	5.2V
		21	22	23	24	25	26	27	28												
		0V	0V	5.2V	0V	3.8V	4.5V	5.1V	5.2V												

TRANSISTOR DC VOLTAGES									
SYMBOL No.	DEVICE	B	C	E	SYMBOL No.	DEVICE	B	C	E
Q1	2SC2274	-0.6V	11.9V	0V	Q12	2SC536	0.7V	0V	0V
Q2	2SA984	-0.6V	-12.3V	0V	Q14	2SC536	0V	5.2V	0V
Q3	2SD863	-0.5V	11.9V	0V	Q15	2SC536	0.6V	0V	0V
Q4	2SB764	-0.5V	-12.3V	0V	Q16	2SC2274	0V	11.9V	1.1V
Q5,6	2SD1012	0.7V	0V	0V	Q17	2SC2274	5.9V	9.8V	5.2V
Q7	2SC536	0.7V	0V	0V	Q18	2SC536	0.2V	11.1V	0V
Q8	2SA608	11.2V	11.9V	11.9V	Q19	2SC536	2.2V	1.6V	1.6V
Q9	2SC536	0.6V	0.1V	0V	Q20	2SC536	0V	1.6V	1.1V
Q10	2SC536	0V	0.1V	0V	Q21	2SC536	0.7V	0V	0V
Q11	2SC536	0V	0V	0V					

SWITCH P.C. BOARD
(BOTTOM VIEW)

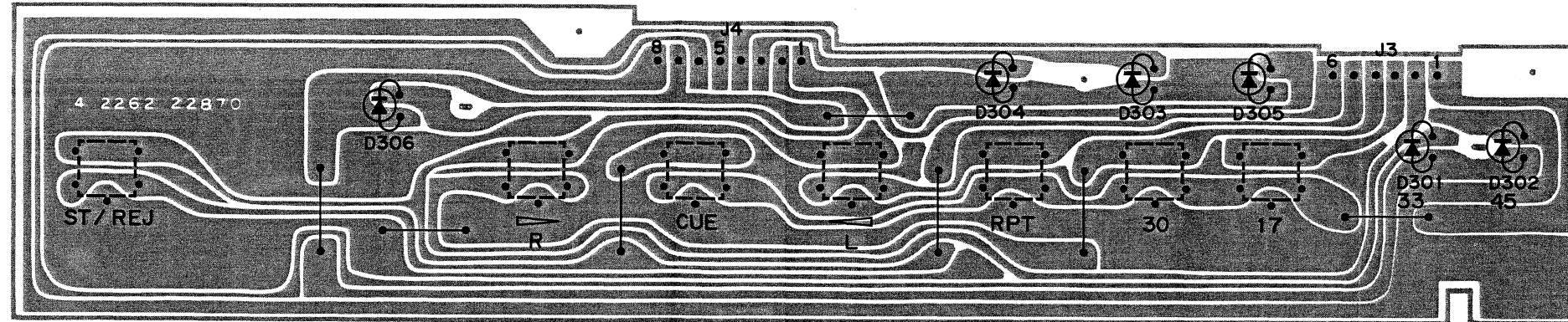

TERMINAL P.C. BOARD
(BOTTOM VIEW)

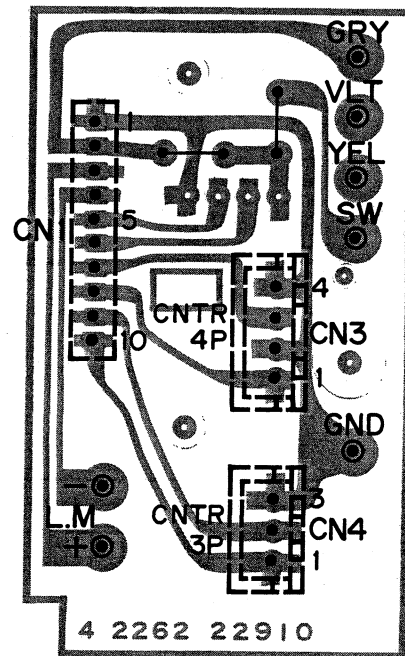

PIR P.C. BOARD
(BOTTOM VIEW)

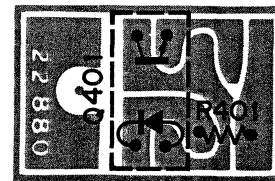

PCR P.C. BOARD
(BOTTOM VIEW)

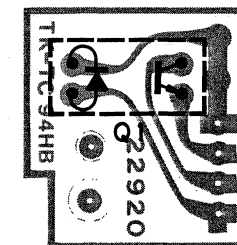

SPEED P.C. BOARD
(BOTTOM VIEW)

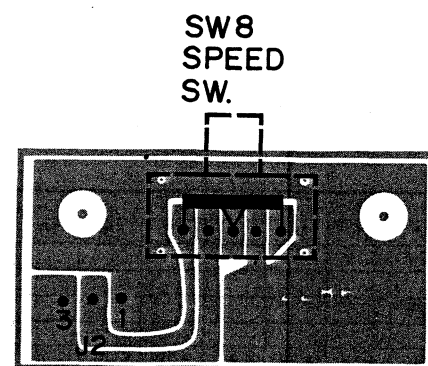

POWER INDICATOR P.C. BOARD
(BOTTOM VIEW)

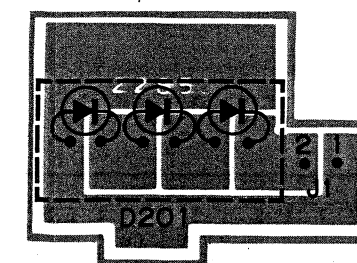

P.C.BOARD PARTS LIST

Ref. No.	Part No.	Description	Q'ty	Ref. No.	Part No.	Description	Q'ty	
CONTROL P.C.B. ASSY				C9	CC6-8-1500-KD00C	Ceramic	680pF 50V ±10%	
PCB1	141-0-1939-10031	Control P.C.B. Assy	1	C10	CD3-3-5500-0001V	Electrolytic	3.3μF 50V	
	4-2369-73780	RT Pin 1P	1	C11	CD1-0-4500-0001V	Electrolytic	0.1μF 50V	
	103-3-1903-00611	Screw, Brazier Hd. Tapping-2, +M3.0x6	2	C12	CD1-0-4500-0001V	Electrolytic	0.1μF 50V	
	111-2-6220-11100	Wire Wrap Terminal	15	C13	CD1-0-7160-0001V	Electrolytic	100μF 16V	
	131-2-6201-21500	Plate Heat Sink	2	C14	CD1-0-7160-0001V	Electrolytic	100μF 16V	
CN1	4-2362-00140	Plug 10P	1	C15	CM1-8-3500-K00SV	Mylar	0.018μF 50V ±10%	
CN2	4-2369-73150	Connector 5P	1	C16	CM1-8-3500-K00SV	Mylar	0.018μF 50V ±10%	
CN5	4-2369-73130	Connector 3P	1	C17	CM4-7-2500-K00SV	Mylar	0.0047μF 50V ±10%	
J1	131-2-9800-01040	Jumper	1	C18	CM4-7-2500-K00SV	Mylar	0.0047μF 50V ±10%	
J2	131-2-9800-01041	Jumper	1	C19	CC1-0-1500-KD00C	Ceramic	100pF 50V ±10%	
J3	131-2-9800-01058	Jumper	1	C20	CC1-0-1500-KD00C	Ceramic	100pF 50V ±10%	
J4	131-2-9800-01099	Jumper	1	C21	CD4-7-6100-0001V	Electrolytic	47μF 10V	
L1	4-2532-00540	Choke Coil (47μH)	1	C22	CD4-7-6100-0001V	Electrolytic	47μF 10V	
CF1	4-2259-70780	CSB 800K	1	C23	CC1-0-1500-JD00R	Ceramic	100pF 50V ±5%	
TH1	204-5-9000-05000	Thermistor, SDT 500	1	C24	CC1-0-1500-JD00R	Ceramic	100pF 50V ±5%	
D1	202-5-2810-44210	Diode, DS 442	1	C25	CD4-7-5250-0001V	Electrolytic	4.7μF 25V	
D2	202-5-2810-44210	Diode, DS 442	1	C26	CD4-7-5250-0001V	Electrolytic	4.7μF 25V	
D3	202-5-2810-44210	Diode, DS 442	1	C27	CC1-0-1500-JD00R	Ceramic	100pF 50V ±5%	
D4	202-5-2810-44210	Diode, DS 442	1	C28	CC1-0-1500-JD00R	Ceramic	100pF 50V ±5%	
D5	202-5-2810-44210	Diode, DS 442	1	C29	CD1-0-5500-0001V	Electrolytic	1μF 50V	
D6	202-5-2810-44210	Diode, DS 442	1	C30	CD4-7-5500-0001V	Electrolytic	4.7μF 50V	
D7	202-5-2470-13540	Diode, DS 135	1	C31	CD1-0-6250-0001V	Electrolytic	10μF 25V	
D8	202-5-2810-44210	Diode, DS 442	1	C33	CD2-2-6250-0001V	Electrolytic	22μF 25V	
D9	202-5-2810-44210	Diode, DS 442	1	C34	CD2-2-6250-0001V	Electrolytic	22μF 25V	
D10	202-5-2810-44210	Diode, DS 442	1	C35	CC1-0-3500-ZG00C	Ceramic	0.01μF 50V +80,-20%	
D12	202-5-3210-05613	Zener Diode, GZA5.6Z	1	C36	CC1-0-3500-ZG00C	Ceramic	0.01μF 50V +80,-20%	
D13	202-5-2810-44210	Diode, DS 442	1	C37	CD1-0-7160-0001V	Electrolytic	100μF 16V	
D14	202-5-2810-44210	Diode, DS 442	1	C38	CD1-0-7160-0001V	Electrolytic	100μF 16V	
IC1	208-5-8036-41648	IC, LM6416E-489	1	C39	CM1-0-4500-J00TV	Mylar	0.1μF 50V ±5%	
IC2	4-2069-72530	IC, MSM 4049 RS	1	C40	CM1-0-4500-J00TV	Mylar	0.1μF 50V ±5%	
IC3	4-2069-73890	IC, M5218 P	1	C41	CD4-7-6100-0001V	Electrolytic	47μF 10V	
IC4	206-5-9504-01110	IC, LC 4011 B	1	C42	CM1-0-4500-J00TV	Mylar	0.1μF 50V ±5%	
IC5	4-2069-73890	IC, M5218 P	1	C43	CC5-6-2500-KE00C	Ceramic	0.0056μF 50V ±10%	
IC6	4-2069-72560	IC, NJM 7812	1	R1	4-2219-70460	Resistor (10kΩ x 8)	1	
IC7	4-2069-72570	IC, NJM 7912	1	R2	4-2219-71270	Resistor (10kΩ x 4)	1	
Q1	203-5-7252-27460	Transistor, 2SC 2274	1	R3	RD1-0-5161-JH000	Carbon	1MΩ 1/6W ±5%	
Q2	203-5-6820-98460	Transistor, 2SA 984	1	R4	RD1-0-3251-JM000	Carbon	10kΩ 1/4W ±5%	
Q3	203-5-7340-86360	Transistor, 2SD 863	1	R5	RD3-9-1251-JM000	Carbon	390Ω 1/4W ±5%	
Q4	203-5-7350-76460	Transistor, 2SB 764	1	R6	RD3-9-1251-JM000	Carbon	390Ω 1/4W ±5%	
Q5	203-5-4921-01260	Transistor, 2SD 1012	1	R7	RD3-9-1251-JM000	Carbon	390Ω 1/4W ±5%	
Q6	203-5-4921-01260	Transistor, 2SD 1012	1	R8	RD1-8-1251-JM000	Carbon	180Ω 1/4W ±5%	
Q7	203-5-5000-53660	Transistor, 2SC 536	1	R9	RD3-9-1251-JM000	Carbon	390Ω 1/4W ±5%	
Q8	203-5-7230-60860	Transistor, 2SA 608	1	R10	RD1-8-1251-JM000	Carbon	180Ω 1/4W ±5%	
Q9	203-5-5000-53660	Transistor, 2SC 536	1	R11	RD1-0-2251-JM000	Carbon	1kΩ 1/4W ±5%	
Q10	203-5-5000-53660	Transistor, 2SC 536	1	R12	RD2-7-2161-JH000	Carbon	2.7kΩ 1/6W ±5%	
Q11	203-5-5000-53660	Transistor, 2SC 536	1	R13	RD8-2-1161-JH000	Carbon	820Ω 1/6W ±5%	
Q12	203-5-5000-53660	Transistor, 2SC 536	1	R14	RD2-2-2251-JM000	Carbon	2.2kΩ 1/4W ±5%	
Q14	203-5-5000-53660	Transistor, 2SC 536	1	R15	RD4-7-1251-JM000	Carbon	470Ω 1/4W ±5%	
Q15	203-5-5000-53660	Transistor, 2SC 536	1	R16	RD3-9-A251-JM000	Carbon	3.9Ω 1/4W ±5%	
Q16	203-5-7252-27460	Transistor, 2SC 2274	1	R17	RD4-7-1161-JH000	Carbon	470Ω 1/6W ±5%	
Q17	203-5-7252-27460	Transistor, 2SC 2274	1	R18	RD4-7-1161-JH000	Carbon	470Ω 1/6W ±5%	
Q18	203-5-5000-53660	Transistor, 2SC 536	1	R19	RD1-0-2161-JH000	Carbon	1kΩ 1/6W ±5%	
Q19	203-5-5000-53660	Transistor, 2SC 536	1	R20	RD2-7-1161-JH000	Carbon	270Ω 1/6W ±5%	
Q20	203-5-5000-53660	Transistor, 2SC 536	1	R21	RD2-2-4251-JM000	Carbon	220kΩ 1/4W ±5%	
Q21	203-5-5000-53660	Transistor, 2SC 536	1	R22	RD1-0-3251-JM000	Carbon	10kΩ 1/4W ±5%	
C1	CC2-2-1500-KD00C	Ceramic	220pF 50V ±10%	1	R23	RD2-7-1161-JH000	Carbon	270Ω 1/6W ±5%
C2	CC2-2-1500-KD00C	Ceramic	220pF 50V ±10%	1	R24	RD3-9-2161-JH000	Carbon	3.9kΩ 1/6W ±5%
C3	CC3-3-1500-KD00C	Ceramic	330pF 50V ±10%	1	R25	RD1-2-2161-JH000	Carbon	1.2kΩ 1/6W ±5%
C4	CI1-0-3250-MF00R	Boundary	0.01μF 25V ±20%	1	R26	RD2-2-2161-JH000	Carbon	2.2kΩ 1/6W ±5%
C5	CM1-0-4500-J00TV	Mylar	0.1μF 50V ±5%	1	R27	RD4-7-2161-JH000	Carbon	4.7kΩ 1/6W ±5%
C6	CM1-5-4500-J00TV	Mylar	0.15μF 50V ±5%	1	R28	RD4-7-1161-JH000	Carbon	470Ω 1/6W ±5%
C7	CI1-0-3250-MF00R	Boundary	0.01μF 25V ±20%	1	R29	RD3-9-A251-JM000	Carbon	3.9Ω 1/4W ±5%
C8	CC3-3-1500-KD00C	Ceramic	330pF 50V ±10%	1	R30	RD4-7-1161-JH000	Carbon	470Ω 1/6W ±5%

P.C.BOARD PARTS LIST (Continued)

Ref. No.	Part No.	Description	Q'ty	Ref. No.	Part No.	Description	Q'ty	
R31	RD4-7-1161-JH000	Carbon	470Ω 1/6W ±5%	1	R98	RD5-6-3161-JH000	Carbon 56kΩ 1/6W ±5%	1
R32	RD1-0-2161-JH000	Carbon	1kΩ 1/6W ±5%	1	R99	RH4-7-1501-JZ000	Metal 470Ω 1/2W ±5%	1
R33	RD1-0-2251-JM000	Carbon	1kΩ 1/4W ±5%	1	R100	RH3-3-1102-JZ000	Metal 330Ω 1W ±5%	1
R34	RD1-0-2251-JM000	Carbon	1kΩ 1/4W ±5%	1	R101	RD1-0-2251-JM000	Carbon 1kΩ 1/4W ±5%	1
R35	RD1-0-2251-JM000	Carbon	1kΩ 1/4W ±5%	1	R102	RD1-0-2251-JM000	Carbon 1kΩ 1/4W ±5%	1
R36	RD1-0-2161-JH000	Carbon	1kΩ 1/6W ±5%	1				
R37	RD4-7-2161-JH000	Carbon	4.7kΩ 1/6W ±5%	1				
R38	RD5-6-1251-JM000	Carbon	560Ω 1/4W ±5%	1				
R39	RD1-0-0251-JS000	Carbon	10Ω 1/4W ±5%	1				
R40	RD1-5-3251-JM000	Carbon	15kΩ 1/4W ±5%	1				
R41	RD1-0-3251-JM000	Carbon	10kΩ 1/4W ±5%	1				
R42	RD1-0-3251-JM000	Carbon	10kΩ 1/4W ±5%	1				
R43	RD1-0-3251-JM000	Carbon	10kΩ 1/4W ±5%	1				
R44	RD2-2-3161-JH000	Carbon	22kΩ 1/6W ±5%	1				
R45	RD1-0-3251-JM000	Carbon	10kΩ 1/4W ±5%	1				
R46	RD1-0-3161-JH000	Carbon	10kΩ 1/6W ±5%	1				
R47	RD1-0-3161-JH000	Carbon	10kΩ 1/6W ±5%	1				
R51	RD1-0-3161-JH000	Carbon	10kΩ 1/6W ±5%	1				
R52	RD1-0-3161-JH000	Carbon	10kΩ 1/6W ±5%	1				
R53	RD1-0-2161-JH000	Carbon	1kΩ 1/6W ±5%	1				
R54	RD1-0-2161-JH000	Carbon	1kΩ 1/6W ±5%	1				
R55	RD1-0-4161-JH000	Carbon	100kΩ 1/6W ±5%	1				
R56	RD1-0-4161-JH000	Carbon	100kΩ 1/6W ±5%	1				
R57	RD1-0-2251-JM000	Carbon	1kΩ 1/4W ±5%	1				
R58	RD1-0-2251-JM000	Carbon	1kΩ 1/4W ±5%	1				
R59	RD2-2-4161-JH000	Carbon	220kΩ 1/6W ±5%	1				
R60	RD2-2-4161-JH000	Carbon	220kΩ 1/6W ±5%	1				
R61	RD1-5-3161-JH000	Carbon	15kΩ 1/6W ±5%	1				
R62	RD1-5-3161-JH000	Carbon	15kΩ 1/6W ±5%	1				
R63	RD3-3-1251-JM000	Carbon	330Ω 1/4W ±5%	1				
R64	RD3-3-1161-JH000	Carbon	330Ω 1/6W ±5%	1				
R65	RD1-0-4251-JM000	Carbon	100kΩ 1/4W ±5%	1				
R66	RD1-0-4251-JM000	Carbon	100kΩ 1/4W ±5%	1				
R67	RD1-0-4251-JM000	Carbon	100kΩ 1/4W ±5%	1				
R68	RD1-0-4251-JM000	Carbon	100kΩ 1/4W ±5%	1				
R69	RD1-0-2161-JH000	Carbon	1kΩ 1/6W ±5%	1				
R70	RD1-0-2161-JH000	Carbon	1kΩ 1/6W ±5%	1				
R71	RD1-0-4251-JM000	Carbon	100kΩ 1/4W ±5%	1				
R72	RD3-3-2161-JH000	Carbon	3.3kΩ 1/6W ±5%	1				
R73	RD4-7-3161-JH000	Carbon	47kΩ 1/6W ±5%	1				
R74	RD1-0-3251-JM000	Carbon	10kΩ 1/4W ±5%	1				
R75	RD1-0-4161-JH000	Carbon	100kΩ 1/6W ±5%	1				
R76	RD1-0-4161-JH000	Carbon	100kΩ 1/6W ±5%	1				
R77	RD2-2-3251-JM000	Carbon	22kΩ 1/4W ±5%	1				
R78	RD3-3-2161-JH000	Carbon	3.3kΩ 1/6W ±5%	1				
R79	RD4-7-3161-JH000	Carbon	47kΩ 1/6W ±5%	1				
R80	RD2-2-2251-JM000	Carbon	2.2kΩ 1/4W ±5%	1				
R81	RD4-7-3161-JH000	Carbon	47kΩ 1/6W ±5%	1				
R82	RD6-8-2161-JH000	Carbon	6.8kΩ 1/6W ±5%	1				
R83	RD6-8-3251-JM000	Carbon	68kΩ 1/4W ±5%	1				
R84	RD1-0-3161-JH000	Carbon	10kΩ 1/6W ±5%	1				
R85	RD1-0-3251-JM000	Carbon	10kΩ 1/4W ±5%	1				
R86	RH4-7-0102-JZ000	Metal	47Ω 1W ±5%	1				
R87	RD6-8-1251-JM000	Carbon	680Ω 1/4W ±5%	1				
R88	RD2-2-1251-JM000	Carbon	220Ω 1/4W ±5%	1				
R89	RH4-7-1102-JZ000	Metal	470Ω 1W ±5%	1				
R90	RD1-0-3161-JH000	Carbon	10kΩ 1/6W ±5%	1				
R91	RD1-0-3251-JM000	Carbon	10kΩ 1/4W ±5%	1				
R92	RD1-0-3161-JH000	Carbon	10kΩ 1/6W ±5%	1				
R93	RD4-7-2161-JH000	Carbon	4.7kΩ 1/6W ±5%	1				
R94	RD5-6-3161-JH000	Carbon	56kΩ 1/6W ±5%	1				
R95	RD1-0-3251-JM000	Carbon	10kΩ 1/4W ±5%	1				
R96	RD1-0-3161-JH000	Carbon	10kΩ 1/6W ±5%	1				
R97	RD4-7-2161-JH000	Carbon	4.7kΩ 1/6W ±5%	1				
						POWER INDICATOR P.C.B. ASSY		
					PCB2	141-0-1939-10040	Power Indicator P.C.B. Assy	1
					D201	4-2029-73010	LED, SLF 206 B	1
						SPEED P.C.B. ASSY		
					PCB3	141-0-1939-10050	Speed P.C.B. Assy	1
						141-2-3529-43500	Spacer	1
					SW8	4-2319-76670	Slide Switch (Speed)	1
						SWITCH P.C.B. ASSY		
					PCB4	141-0-1939-10060	Switch P.C.B. Assy	1
						141-2-3519-72900	Spacer	1
					SW1	4-2312-05802	Keyboard Switch	1
					SW2	4-2312-05802	Keyboard Switch	1
					SW3	4-2312-05802	Keyboard Switch	1
					SW4	4-2312-05802	Keyboard Switch	1
					SW5	4-2312-05802	Keyboard Switch	1
					SW6	4-2312-05802	Keyboard Switch	1
					SW7	4-2312-05802	Keyboard Switch	1
					D301	DYY---SLR--54VT-	LED, SLR 54 VT 3	1
					D302	DYY---SLR--54VT-	LED, SLR 54 VT 3	1
					D303	DYY---SLR--54VT-	LED, SLR 54 VT 3	1
					D304	DYY---SLR--54PT-	LED, SLR 54 PT 3	1
					D305	DYY---SLR--54VT-	LED, SLR 54 VT 3	1
					D306	DYY---SLR--54PT-	LED, SLR 54 PT 3	1
						PIR P.C.B. ASSY		
					PCB5	141-0-1939-10070	PIR P.C.B. Assy	1
					CN5	4-2359-78183	Connector 3P Assy	1
					Q401	4-2039-71430	Photo Interrupter	1
					R401	RD5-6-1251-JN000	Carbon 560Ω 1/4W ±5%	1
						TERMINAL P.C.B. ASSY		
					PCB6	141-0-1939-10080	Terminal P.C.B. Assy	1
					CN1	4-2359-78350	Connector 10P Assy	1
					CN3	4-2369-73140	Connector 4P	1
					CN4	4-2369-73130	Connector 3P	1
						111-2-6220-11100	Wire Wrap Terminal	4
						PCR P.C.B. ASSY		
					PCB7	141-0-1939-10090	PCR P.C.B. Assy	1
					Q1	4-2039-71430	Photo Interrupter	1
						NOTES:		
						1. Parts order must contain Model Number, Part Number and Description.		
						2. Ordering quantity of screws and resistors must be multiple of 10 pcs.		

SCHEMATIC DIAGRAM

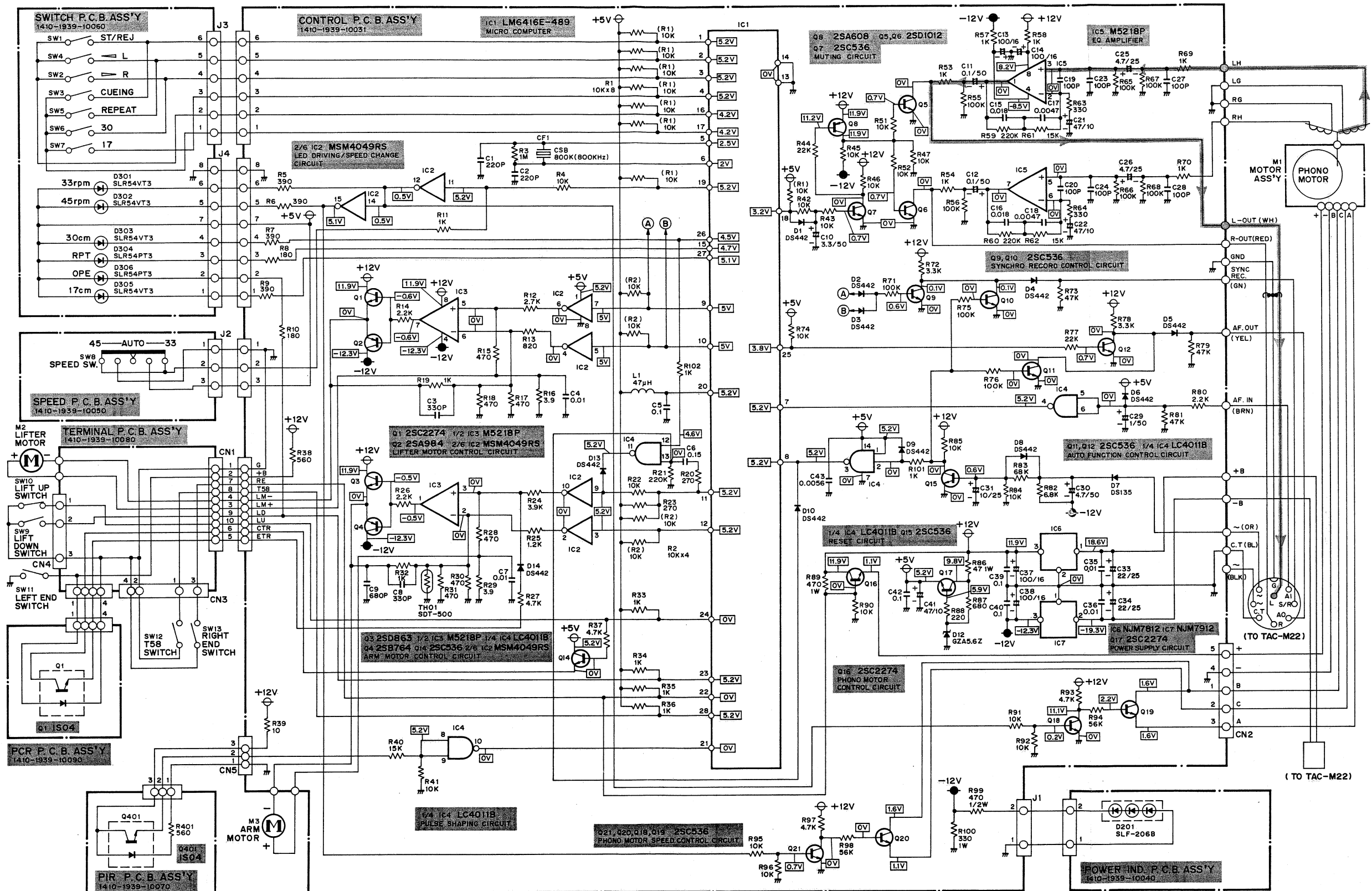

No.	Name	Position	No.	Name	Position
SW1	START / REJECT Switch	OFF	SW8	SPEED SELECT Switch	AUTO
SW2	REVERSE Switch (▶)	OFF	SW9	LIFT DOWN Switch	OFF
SW3	CUEING Switch	OFF	SW10	LIFT UP Switch	ON
SW4	FORWARD Switch (◀)	OFF	SW11	LEFT END Switch	OFF
SW5	REPEAT Switch	OFF	SW12	T58 Switch	OFF
SW6	DISC SIZE Switch (30)	OFF	SW13	RIGHT END Switch	OFF
SW7	DISC SIZE Switch (17)	OFF			

NOTES:

1. All resistors values are indicated in "ohm" (K=10³, M=10⁶).
 2. All capacitors values are indicated in "μF" (P=10⁻¹²).
 3. All voltages indicated on the schematics are measured under the following conditions.
 - a. Use a V.T.V.M.
 - b. All voltages ±10% with respect to chassis ground.
 - c. No signals at input terminals.
 4. This is a basic schematic diagram.
- Because Fisher products are subject to continuous improvement, Fisher Corporation reserves the right to make any changes or modifications without notice.

POINT TO POINT WIRING DIAGRAM

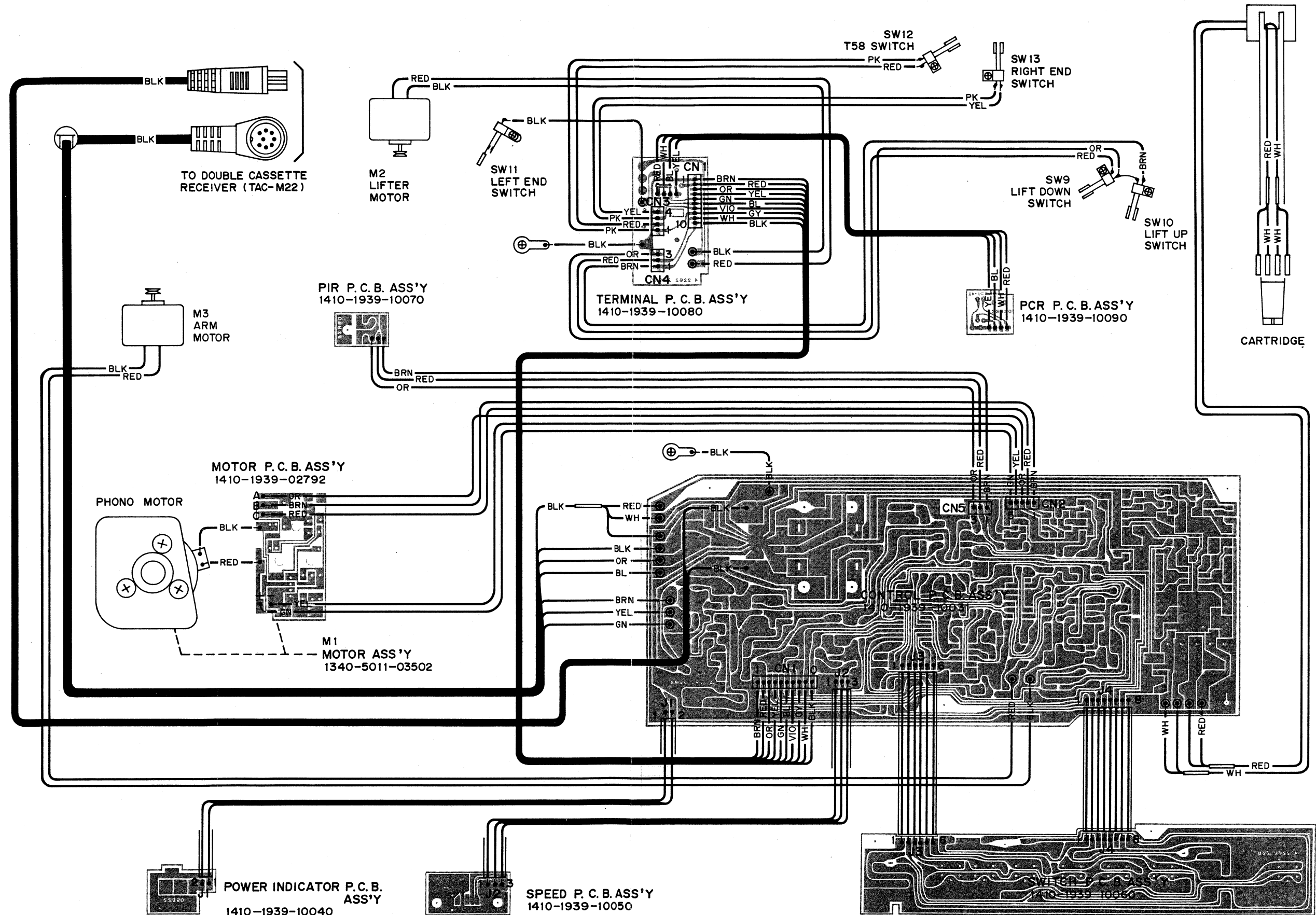

SEMICONDUCTOR LEAD IDENTIFICATION

INTEGRATED CIRCUITS

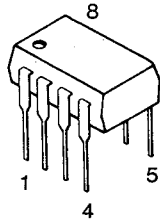

• M5128P

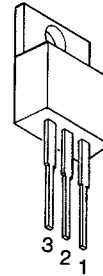

- NJM 7812
- NJM 7912

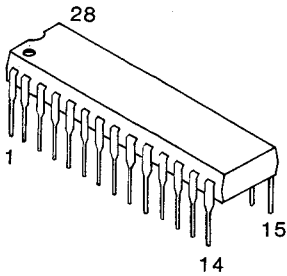

• LM 6416 E-489

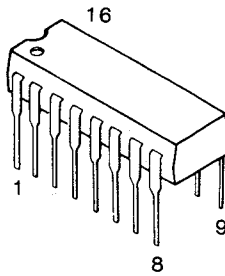

• MSM 4049 RS

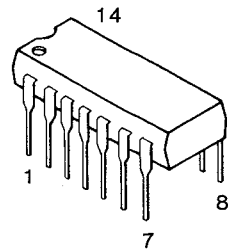

• LC 4011 B

BI-POLAR TRANSISTORS

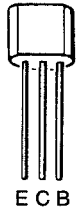

- 2SA 608
- 2SA 984
- 2SC 2274
- 2SC 536



ECB

• 2SD 1012



BCE

- 2SB 764
- 2SD 863

DIODES

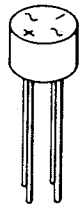

• W02

Cathode



Anode

- DS 442
- GZA 5.6 Z



FISHER

FISHER Hi-Fi Europa Vertriebs GmbH

Stahlgruberring 4 8000 München 82	Tel: 089/420 45-0 Tlx: 524033
Technisches Labor/ Qualitätskontrolle	Durchwahl -120/121
Funkstörmeßlabor	-127/128
Service-Zentrale	
Color TV	-166
Hi-Fi/Audio	-168
Video	-172
Autoradio	-170
Ersatzteillager	-155/156
Techn. Schulung	-174

Weitere Service-Zentralen in BRD (keine Ersatzteilbestellungen)

Offenbach/ Frankfurt	Frankfurter Straße 121 6050 Offenbach	Tel: 069/88 80 45/48 Tlx: 4 12 558	Hamburg	Spaldingstraße 1 2000 Hamburg	Tel: 040/23 12 23/24 Tlx: 2 173 839
Military	Frankfurter Straße 121 6050 Offenbach	Tel: 069/88 80 45/48 Tlx: 4 12 558	Ditzingen	Max-Eyth-Straße 11 7257 Ditzingen	Tel: 07156/50 88 Tlx: 7 245 278
Düsseldorf-Erkrath	Albert-Einstein-Straße 8 4006 Erkrath 1	Tel: 0211/200 05-0 Tlx: 8 588 563	Berlin (Fisher Vertragswerkstatt)	Drewitz & Kaulbach Eisenacher Straße 53 1000 Berlin 62	Tel: 030/781 20 01 Tlx: 186 460

Unser FISHER-Team steht Ihnen jederzeit gerne zur Verfügung. Ersatzteilbestellungen wickeln Sie bitte ausschließlich mit unserer Service-Zentrale München ab.

Senden Sie uns im Garantiefall die ausgefüllte Garantiekarte ein. Bei unverkauften Lagergeräten des Fachhandels gilt als Garantienachweis eine eidesstattliche Versicherung mit eingetragener Modellbezeichnung und Geräte-Nummer oder ein Liefernachweis. Die gleiche Regelung besteht auch für Reparaturaufträge.

Bitte geben Sie unbedingt die Ersatzteil-Nummer und die Modellbezeichnung an.

Sie sparen so wertvolle Zeit. Vielen Dank.

March/'85/2,000 **Printed in Japan**