

SERVICE MANUAL



FISHER

PH 10

Mini Stereo Cassette Player (EUROPE)



SPECIFICATIONS

Power Source		Fast Forward Time	160sec. (with C-60)
DC	3V	Rewind Time	160sec. (with C-60)
	(UM-3, HP 7, AA Cell, Mignonzellen, R 6 x 2)	Frequency Response	
Output Power	18mW x 2 (max.)	Fe ₂ O ₃ :	63Hz ~ 10kHz
Current Consumption (at Vol. min.)		Metal:	63Hz ~ 10kHz
Playback mode	130mA	Signal to Noise Ratio	
Fast Forward mode	230mA	Fe ₂ O ₃ :	43dB
Rewind mode	230mA	Crosstalk (with Fe ₂ O ₃)	
Tape Speed	1-7/8ips. ±3%	Track to Track	55dB
Pitch Control -6:	-6%	Channel Separation (with Fe ₂ O ₃)	35dB
Pitch Control +6:	+6%	Terminal Impedance	
Wow & Flutter	0.5% (WRMS)	Headphone	32Ω

—Specifications subject to change without notice.—

CABINET EXPLODED VIEW

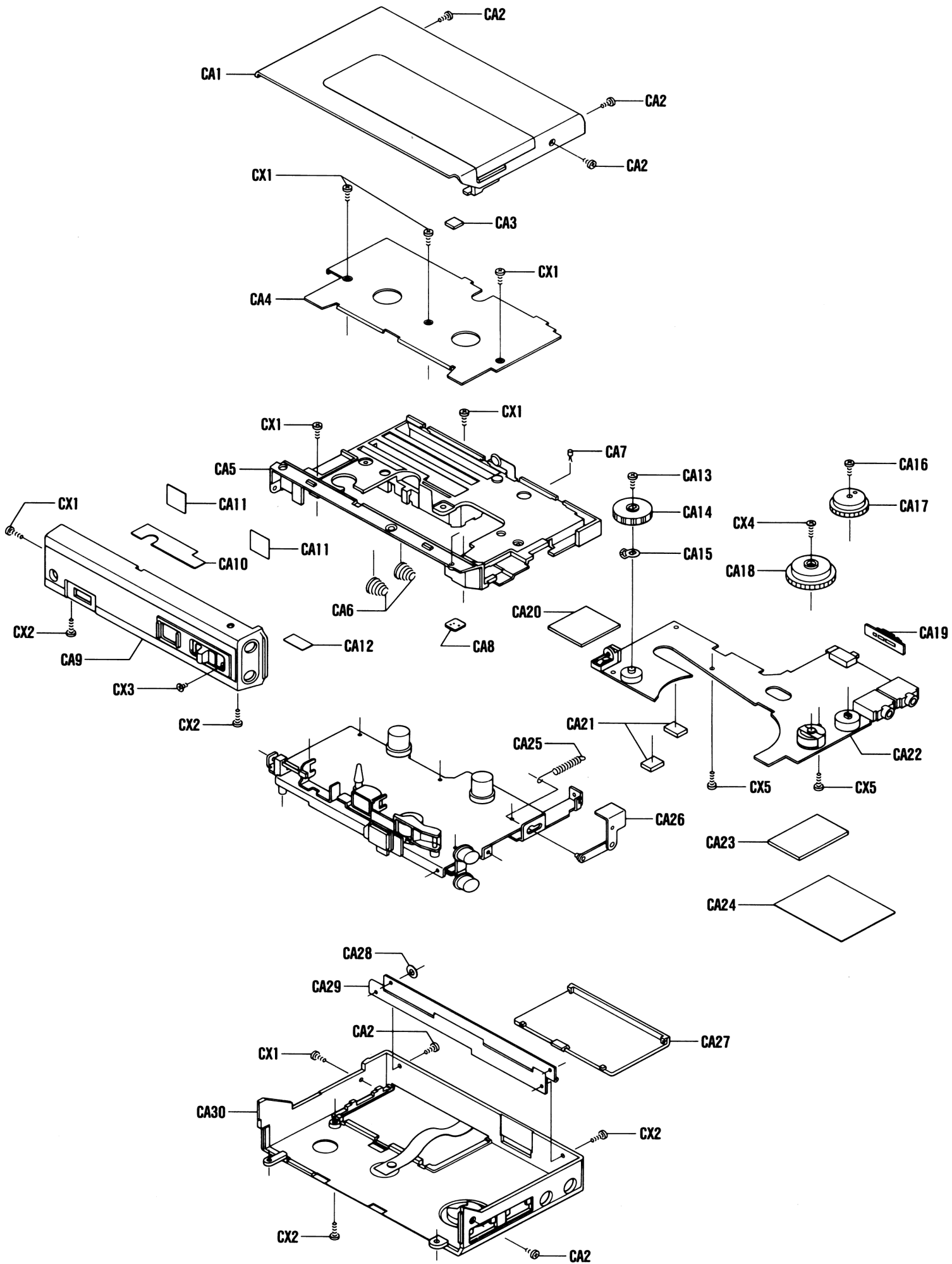

MECHANISM EXPLODED VIEW

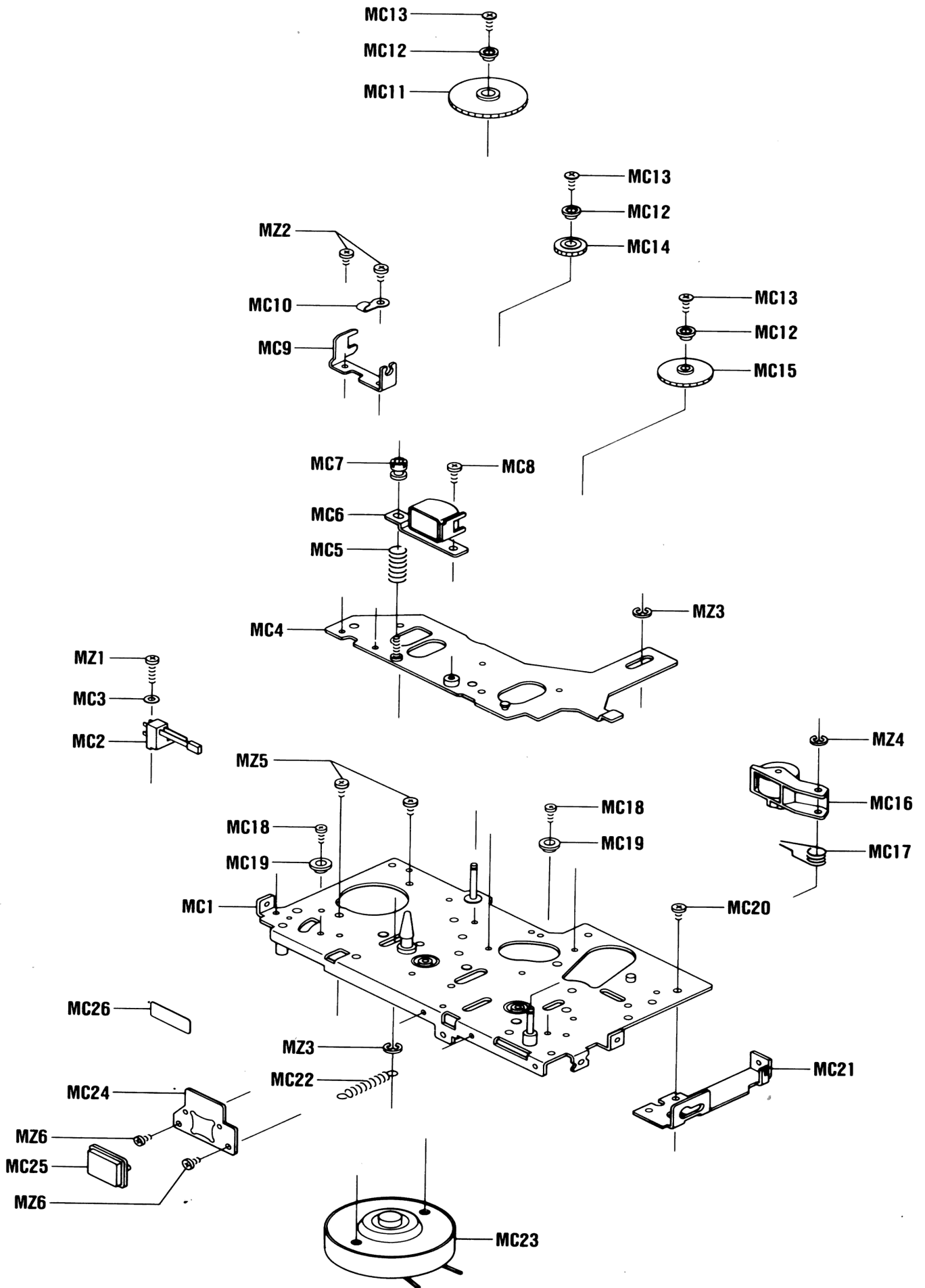

MECHANISM EXPLODED VIEW (Continued)

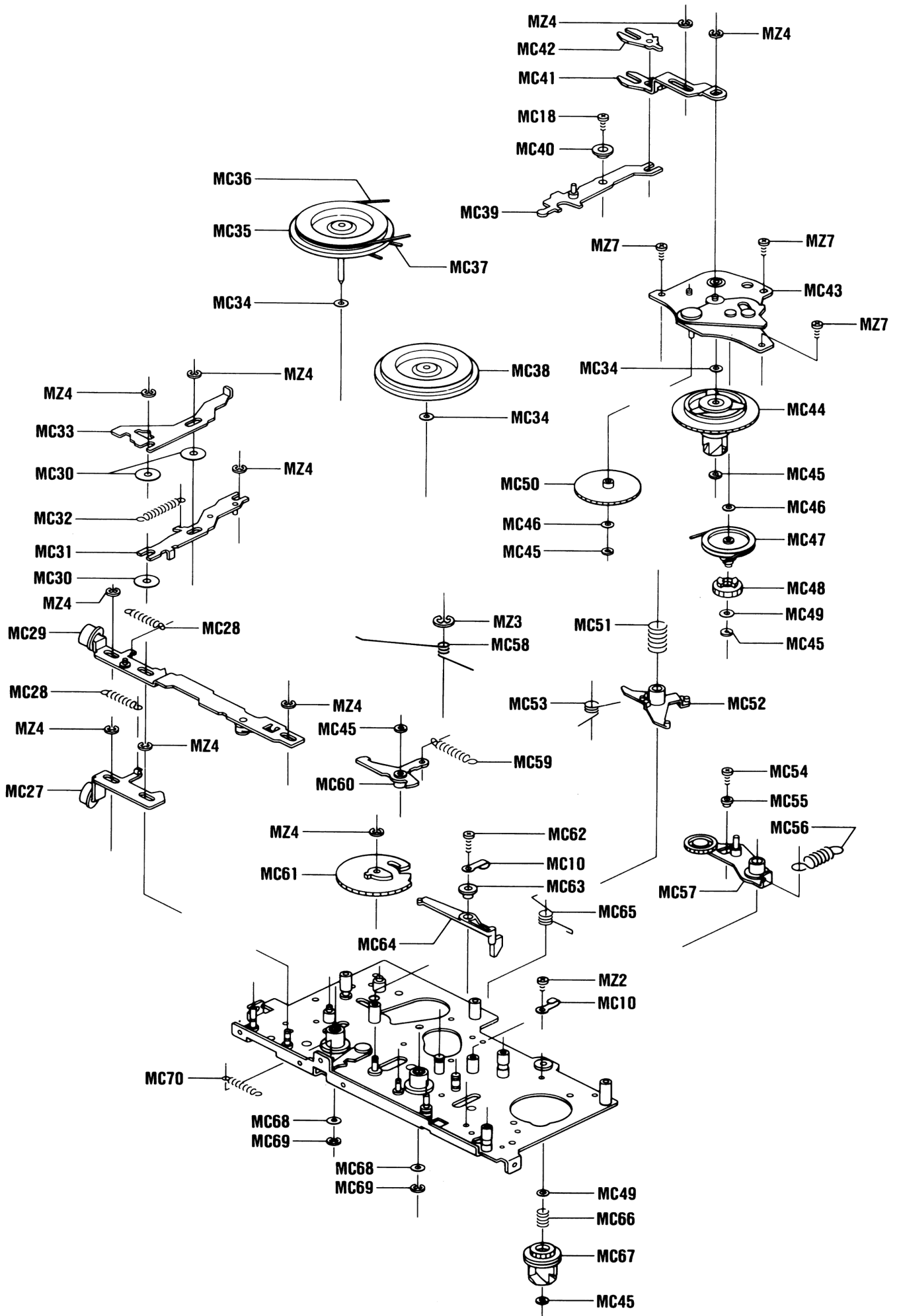

IAGRAM

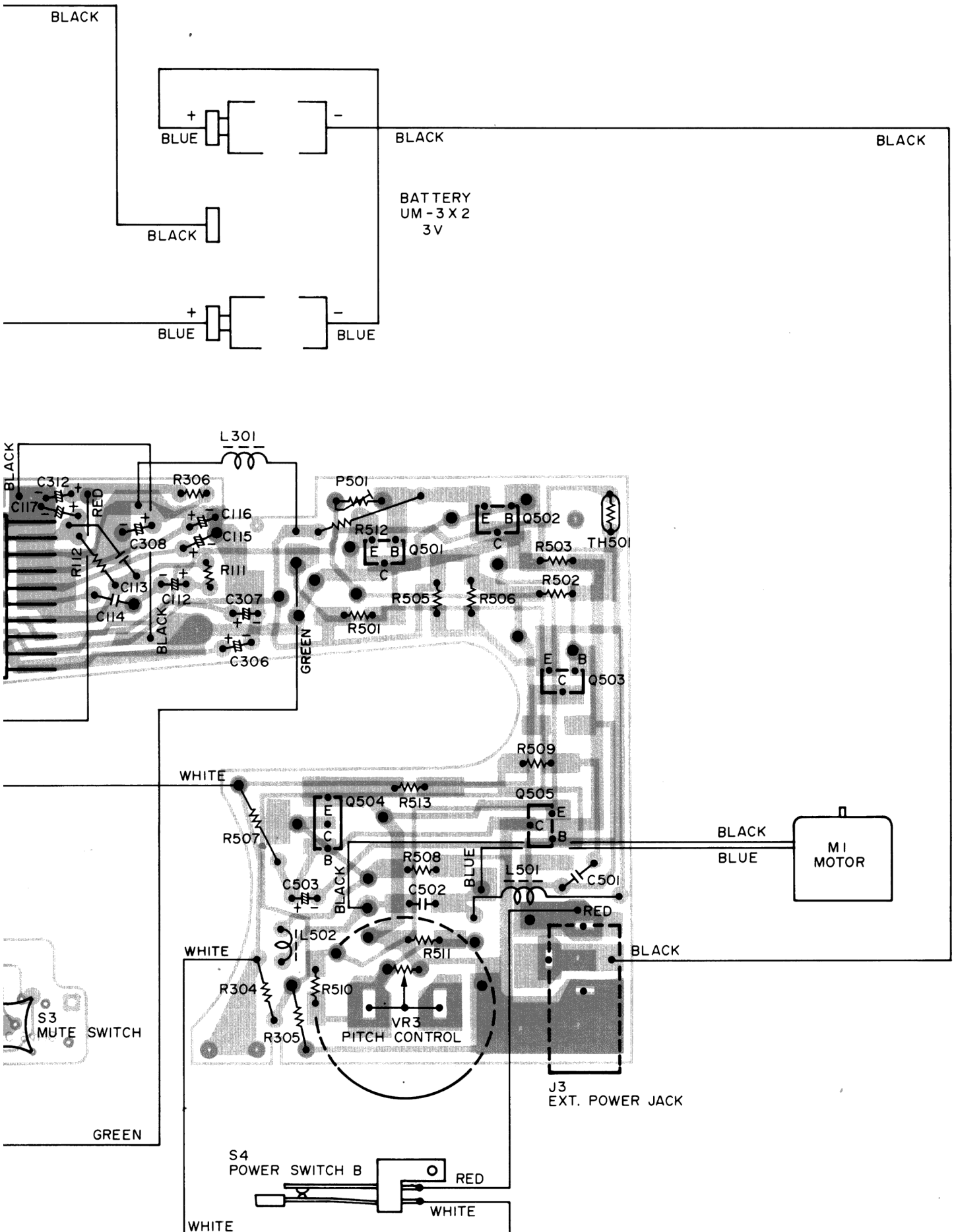

DISASSEMBLY INSTRUCTIONS (Continued)

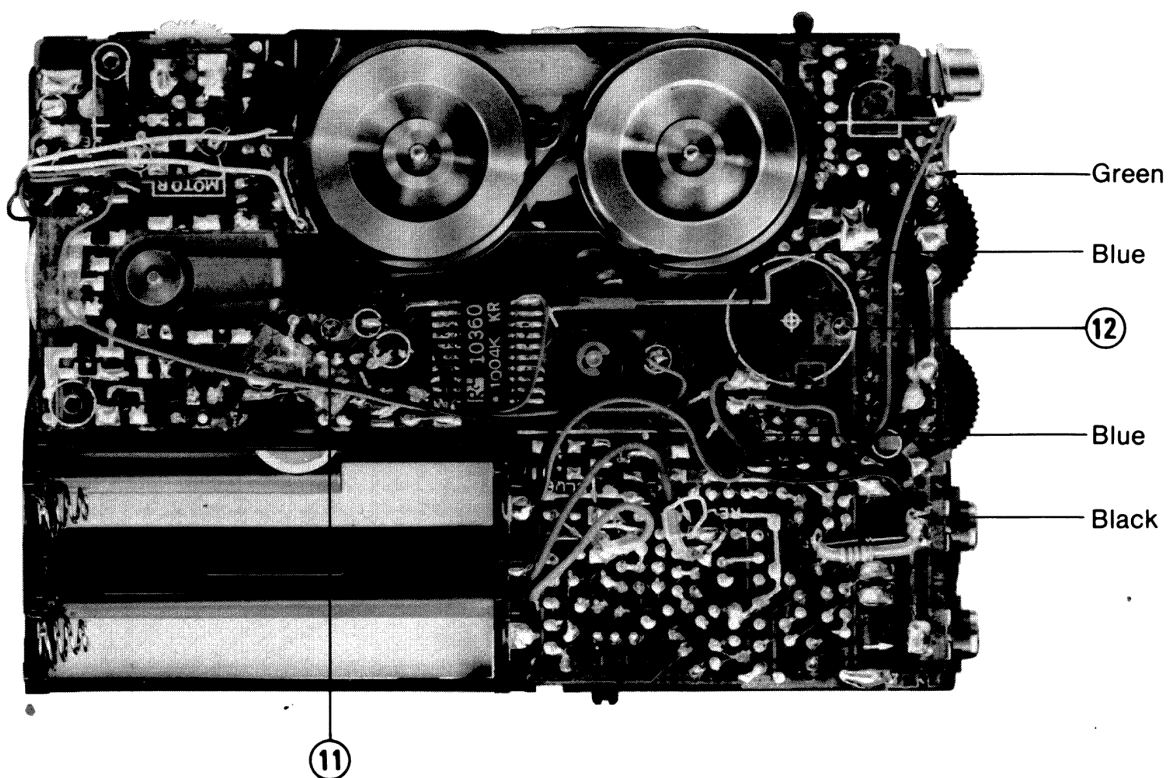
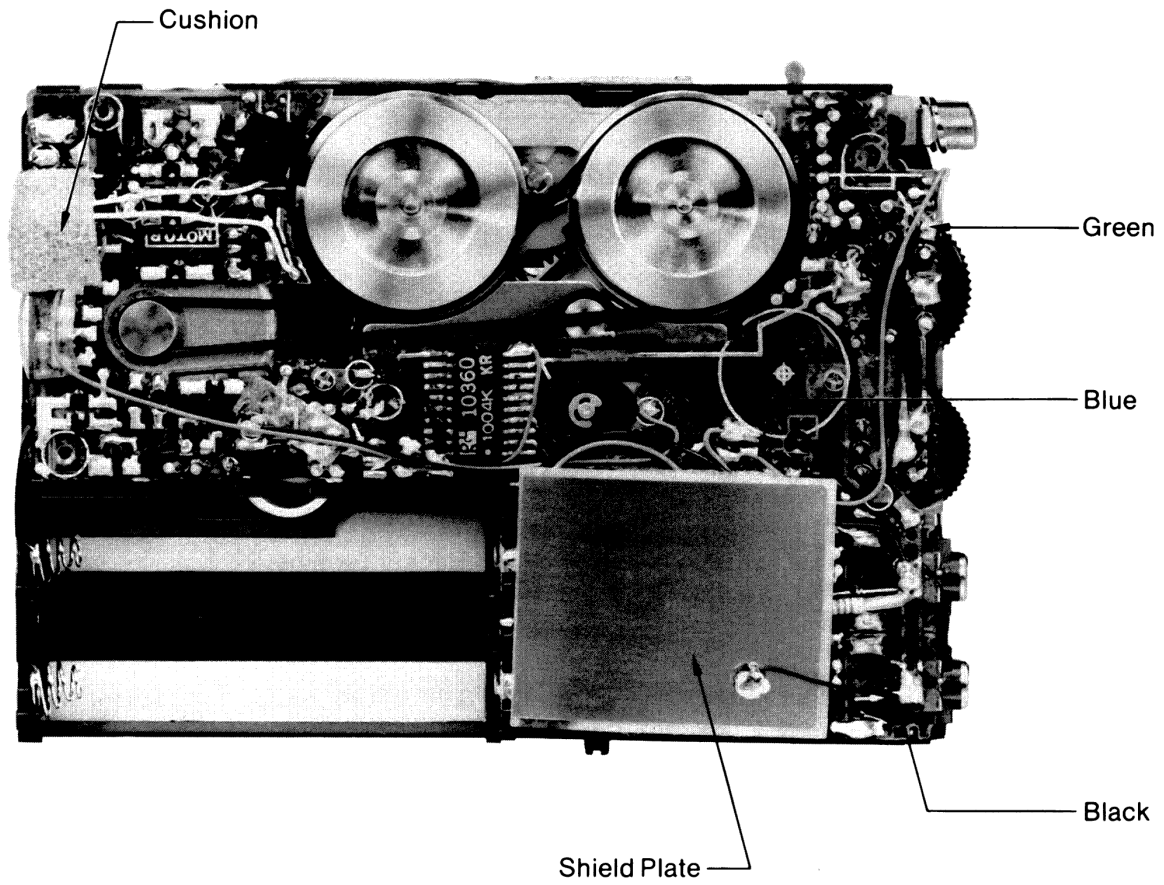

SCHEMATIC

LEFT CH.

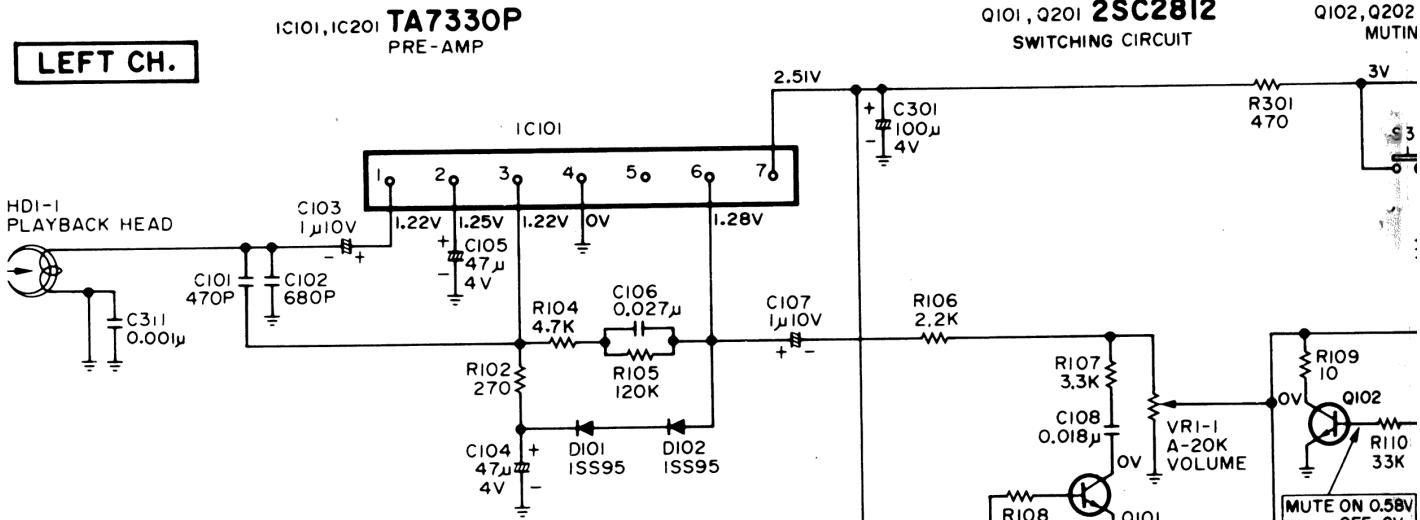

RIGHT CH.

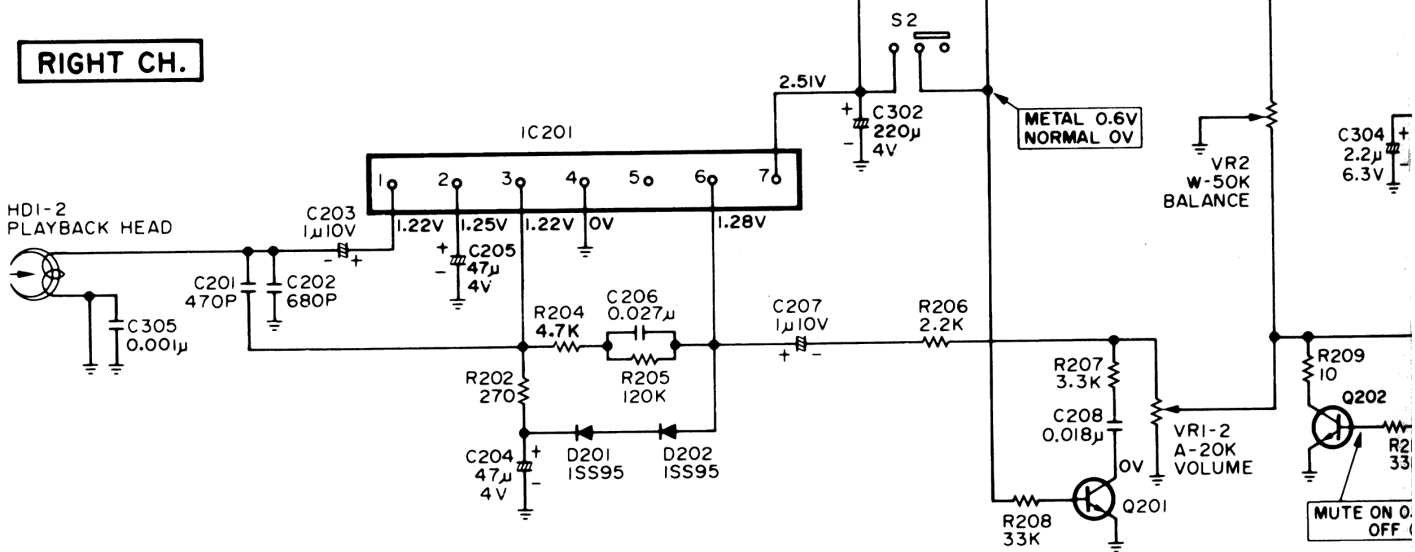

Q501, Q502 **2SC2812** Q503 **2SA1179** Q504 **2SD874** Q505 **2SC2812**
MOTOR GOVERNOR CIRCUIT

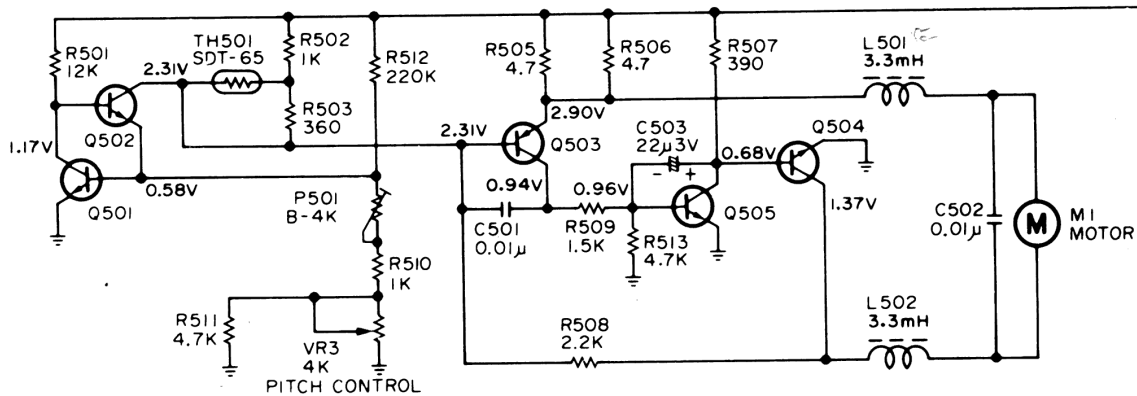

CHEMATIC DIAGRAM

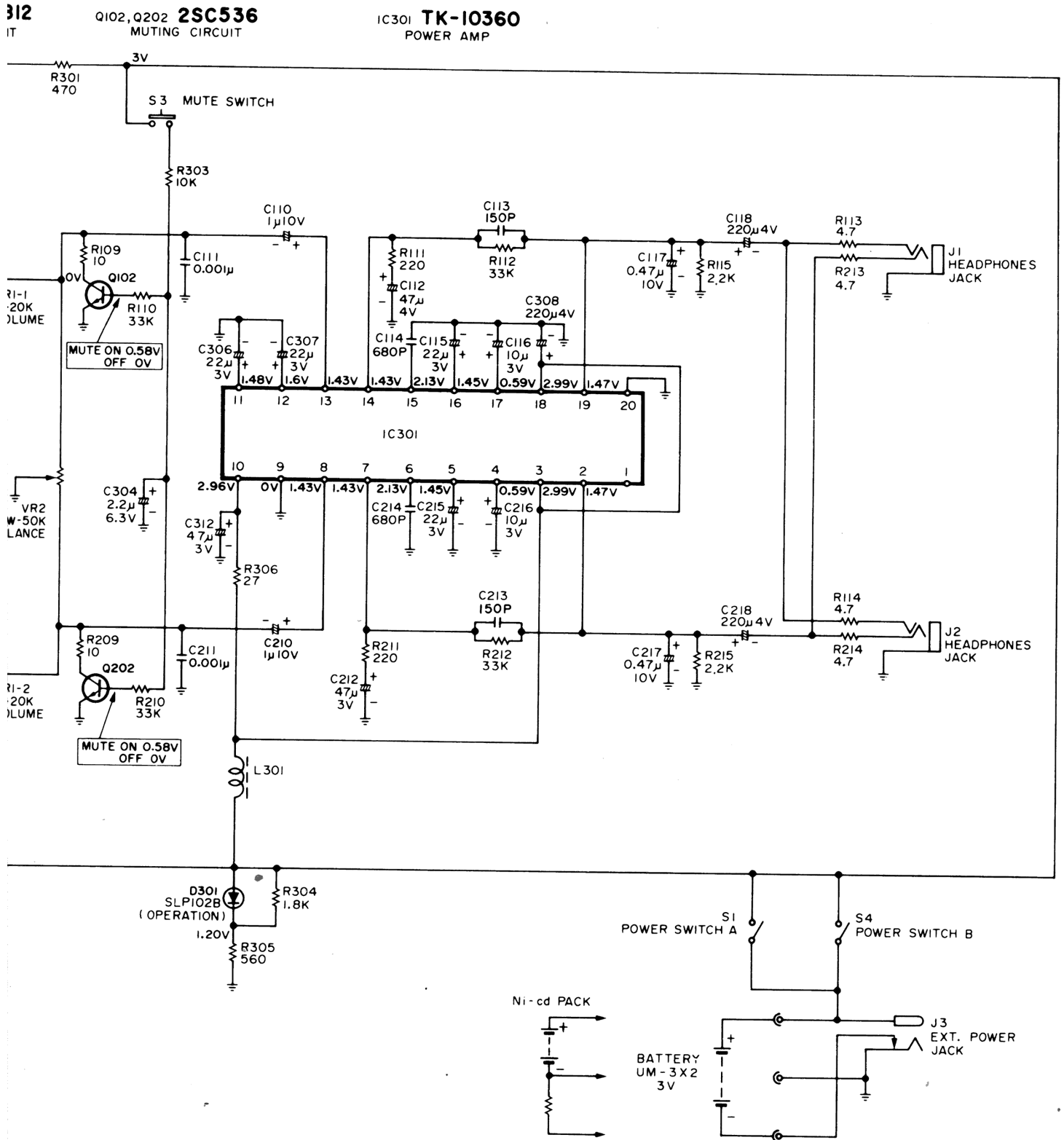

No.	Name	Position
S1	Power Switch A Switch	OFF
S2	Tape Select Switch	NORMAL
S3	Mute Switch	OFF
S4	Power Switch B Switch	OFF