

Stereophonic

**THE FISHER
PHILHARMONIC IV
SERVICE
MANUAL**

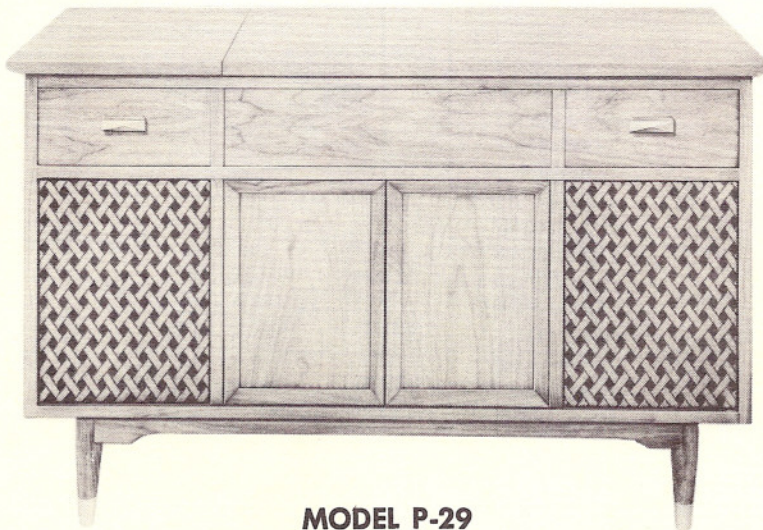

MODEL P-29

PRICE: \$1.00

FISHER RADIO CORPORATION • NEW YORK



THE FISHER P-29



PARTS DESCRIPTION LIST

MAIN CHASSIS

Symbol	Description	Part No.
C5	Capacitor, AM FM Variable	C953-115
C17	Capacitor, Ceramic Trimmer	C662-123
C19, 20	Capacitor, Electrolytic, 50uf, 3V	C50283-1
C28	Capacitor, Ceramic Trimmer	C662-123
C39	Capacitor, Ceramic, 5pF, ± 0.5 pF, N150, 500V	CC20PJ050D5
C42	Capacitor, Ceramic, 10pF, ± 0.5 pF, NPO, 500V	CC20CJ100D5
C62	Capacitor, Electrolytic, 4-Section: A — 20 uf, 350V B — 20uf, 350V C — 40uf, 350V D — 40uf, 350V	C50180-45
C75	Capacitor, Electrolytic, 100uf, 250V	C836-122
C77	Capacitor, Electrolytic, 8uf, 50V	C629-138
C78	Capacitor, Molded, .01uf, 20%, 600V	C2747
C79	Capacitor, Electrolytic, 8uf, 50V	C629-138
C80	Capacitor, Molded, .01uf, 20%, 600V	C2747
C81	Capacitor, Electrolytic, 100uf, 250V	C836-122
CR1	Diode, Silicon, Type 1112	V1112
CR4, 5	Rectifier, Silicon Power	SR50472
F1	Fusè, 2 Amp., Slo-Blo	F643-154
I1, 2, 3, 4	Lamp, #47	I50009-1
L1	Antenna, AM Loop	L50210-36
L2	Coil, FM Antenna	L818-113
L3	Choke, RF, 1.5 Microhenry	L50066-4
L4	Transformer, AM RF	L50210-35
L5	Choke, RF	L629-180
L6	Coil, FM RF	L953-119
L7	Choke, RF, .68 Microhenry	L50066-1
L8	Coil Assembly, FM Oscillator	A5953-116
L9	Coil, AM Oscillator	L50210-28
L10	Choke, RF, .2 Microhenry	L50066-21
L11	Choke, RF, 3.3 Microhenry	L50066-8
PC1, 2	Printed Circuit, Tone Control	PC50187-9
R41, 42	Potentiometer, 500K, Dual Volume	R50160-133
R46	Potentiometer, 500K, Balance	R50160-132
R48, 50	Potentiometer, 500K, Dual Treble	R50160-131
R54, 55	Potentiometer, 500K, Dual Bass	R50160-131
R84	Resistor, Glass, 3.9K, 10%, 7W	RPG7W392K
R85	Resistor, Composition, 330, 10%, 1W	RC30BF331K
R87	Potentiometer, Wirewound, 500, Hum Adj.	R50353-1
R94, 95	Resistor, Variable, 500K	R50150-6
S1	Switch, Selector	S1023-116
S2	Switch, Power	part of R41, 42
T1, 2	Transformer, Output	T992-116-1
T3	Transformer, Power	T1023-115
Z1	Transformer, FM IF	ZZ662-117
Z2	Transformer, AM IF	ZZ2984
Z3	Transformer, FM IF	ZZ2987
Z4	Transformer, AM IF	ZZ2984
Z5	Coil, FM Limiter	ZZ50210-6
Z6	Trcnformer, FM, Ratio Detector	ZZ50210-9
—	Dial Glass	N1023-107
—	Dipole Assembly	A550227-3
—	Brass Escutcheon	A537-118
—	45 RPM Spindle	A50412-6
—	Knob	E50324
—	Jewel, Green	I50162-4
—	Phono Cartridge	G50429
—	Automatic Turntable, Garrard Model AT-6	RC956-105

MULTIPLEX SECTION CAPACITORS

10% tolerance for all fixed capacitors, unless otherwise noted or marked GMV (guaranteed minimum value). All capacitors not marked uf are pF (uf).

Symbol	Description	Part No.
C200	Ceramic, .01uf, +80 — 20%, 500V	C50089-7
C201	Ceramic, 680, 1000V	C50072-2
C203	Ceramic, 220, 1000V	C50183-3
C204	Polystyrene, 470, 5%, 500V	C50394-1
C205	Ceramic, 82, 1000V	C50070-7
C206	Ceramic, 1000, GMV, 500V	C50089-2
C208, 209	Mica, 4700, 5%, 500V	C50332-5
C210	Electrolytic, 1uf, 350V	C50283-3
C211	Ceramic, 1000, GMV, 500V	C50089-2
C214	Mylar, 4700, 400V	C50197-25
C215	Mica, 3900, 5%, 500V	C50332-6
C216, 217	Ceramic, 1000, GMV, 500V	C50089-2
C218	Ceramic, .02uf, 20%, 500V	C50089-5
C219	Ceramic, 330, 1000V	C50183-5
C220	Ceramic, .02uf, 20%, 500V	C50089-5
C221, 222	Mylar, .047uf, 250V	C50197-52
C223, 224	Ceramic, 1000, 1000V	C50072-3
C225, 226	Ceramic, 2200, 1000V	C50072-5

RESISTORS

Symbol	Description	Part No.
In ohms, 5% tolerance, 1/8 W unless otherwise noted. K=Kilohms, M=Megohms.		
R200	Composition, 22M, 10%, 1/2 W	RC20BF226K
R201	Composition, 4.7K, 1/2 W	RC20BF472J
R202	Composition, 15K, 1/2 W	RC20BF153J
R203	Composition, 10M, 10%, 1/2 W	RC20BF106K
R205	Dep. Carbon, 220K, 1/2 W	R33DC224J
R206	Dep. Carbon, 1M	R12DC105J
R208	Dep. Carbon, 22K	R12DC223J
R209, 210,		
211, 212	Dep. Carbon, 33K	R12DC333J
R213, 214	Dep. Carbon, 100K	R12DC104J
R215	Potentiometer, 50K, MPX Separation	R50150-4
R216	Composition, 22M, 10%, 1/2 W	RC20BF226K
R217, 218	Dep. Carbon, 18K, 1/2 W	R33DC183J
R219, 220	Dep. Carbon, 15K, 1/2 W	R33DC153J
R221	Composition, 22M, 10%, 1/2 W	RC20BF226K
R222, 223	Dep. Carbon, 27K	R12DC273J
R224, 225	Dep. Carbon, 22K	R12DC223J
R226, 227,		
228, 229,		
230	Dep. Carbon, 1M	R12DC105J

MISCELLANEOUS

Symbol	Description	Part No.
CR102, 103	Diode, Type 1112	V-1112
L100	Coil, Low Pass	L50210-30
L102, 103	Coil, 20 MH	L50334-2
Z100	Transformer, 19Kc	ZZ50210-34
Z101	Coil, 38Kc	ZZ50210-33



ALIGNMENT INSTRUCTIONS • MULTIPLEX SECTION

STEPS	GENERATOR			INDICATOR	ALIGNMENT		
	CONNECTION	AUDIO FREQUENCY	RF MODULATION	TYPE & CONNECTION	ADJUST	INDICATION	NOTES
1	Audio oscillator connected to lug 1	80 KC—1 volt	None	AC VTVM to junction of C210 and R228	L100 (Use hex alignment tool)	Minimum voltage	
2	Multiplex generator audio output to lug 1 (See Note 1)	19 KC (± 5 cps) pilot tone, 100 mv	None	DC VTVM to T.S.P. 101	Z100 top and bottom (Use hex alignment tool)	Maximum voltage	1
3	Same as Step 2	19 KC pilot tone, 50 mv	None	Scope horiz. input to 19 KC output of gen.; vert. input to junction of C216 and R209. External sweep	Z101 (Use K-tran alignment tool)	Stable 2:1 Lissajous pattern. Disregard phase of pattern	1
4	Same as Step 2	19 KC	None	Same as Step 3	Vary generator 19 KC output from 50 to 200 mv	Lissajous pattern should remain stationary over the entire 150 mv range	1, 2
5	Same as Step 2	1000 cps on left (A) channel only, 1 volt rms (2.8 P-P)	None	AC VTVM and scope vert. input to channel A output lug. Internal sweep. DC VTVM to T.S.P. 101	Z100 top (Use hex tool)	Maximum indication on AC VTVM. Clean 1000 cps waveform on scope	1, 3
6	Same as Step 2	1000 cps on right (B) channel only, 1 volt rms (2.8 P-P)	None	Same as Step 5	MPX separation R215	Minimum reading on AC VTVM should be at least 33 db below reading obtained in Step 5	1
7	Same as Step 2	Same as Step 6	None	Move scope input and AC VTVM to channel B output lug	-----	Note and record voltage reading on AC VTVM	1
8	Same as Step 2	1000 cps on left (A) channel only, 1 volt rms (2.8 P-P)	None	Same as Step 7	-----	AC VTVM reading should be at least 33 db below reading observed in Step 7	1
9	Same as Step 2	8000 cps on right (B) channel only, 1 volt rms (2.8 P-P)	None	Same as Step 7	-----	AC VTVM reading should be the same as observed in Step 7	1
10	Same as Step 2	8000 cps on left (A) channel only, 1 volt rms (2.8 P-P)	None	Same as Step 7	-----	AC VTVM reading should be at least 18 db below reading observed in Step 9	1
11	Repeat Steps 9 and 10 with scope and AC VTVM connected to channel A output lug, but start with 8000 cps applied to left channel for first reading, then switch to right channel for second reading.						
12	Multiplex generator RF output to 300-ohm antenna terminals	1000 cps on left (A) channel only	100% (75 KC Dev.) No pre-emphasis	Move scope input and AC VTVM to channel A output lug	-----	Note and record voltage reading on AC VTVM	4
13	Same as Step 12	1000 cps on right (B) channel only	Same as Step 12	Same as Step 12	R215	Minimum reading on AC VTVM should be at least 33 db below reading observed in Step 12	4
14	Same as Step 12	8000 cps on left (A) channel only	Same as Step 12	Same as Step 12	-----	AC VTVM reading should be 10 db below reading observed in Step 12	4
15	Same as Step 12	8000 cps on right (B) channel only	Same as Step 12	Same as Step 12	-----	AC VTVM reading should be 28 db below reading observed in Step 12	4

NOTE: The above procedure is based on the use of the FISHER Model 300 Multiplex Generator.

1 — In steps 2 through 11, the audio output of the Multiplex Generator should be connected to lug 1 of the multiplex sub-chassis through a 12,000 ohm, 1/2-watt, carbon resistor, and a 180 uuf capacitor should be connected between lug 1 and ground. The wiring from the MPX TEST jack on the main chassis to lug 1 must be disconnected during Steps 2 through 11.

2 — The vertical amplitude of the Lissajous pattern will increase slightly

as the generator output is increased. This is a normal occurrence.

3 — If DC VTVM reading falls below -9 volts when maximum reading is obtained on the AC VTVM, readjust bottom of Z100, then repeat Step 5. Repeat this procedure until maximum AC VTVM reading is obtained with DC VTVM reading greater than -9 volts.

4 — Tune the FISHER to the RF output frequency of the Multiplex Generator.

ALIGNMENT INSTRUCTIONS

Read These Instructions With Extreme Care Before Attempting Alignment.

CHASSIS: Turn the station selector completely counterclockwise, without forcing. Dial pointer should be at zero index mark on logging scale. If not, reset the dial pointer. Disconnect the external antennas and the antenna link. When using an oscilloscope for alignment, set the output level controls for no overload, as shown by the proper waveform shape. Connect loads to main output and turn volume control to minimum.

SIGNAL GENERATORS: The signal generator equipment must be able to supply the following:

FM RF modulated 30% (± 22.5 KC deviation) at 400 cps; AM RF modulated 30% at 400 cps.

INDICATOR: DC VTVM, AC VTVM, and scope for alignment.

ALIGNMENT: Allow the chassis and test instruments to warm up for at least fifteen minutes. Adjust the line voltage for 117 volts AC, 50-60 cycles. Use fully insulated tools: a small screwdriver for all trimming capacitors; a K-Tran tool for Z1, Z2, Z3, Z4; a hex tool for L2, L4, L6, L8, L9, Z5 and Z6. For AM alignment, short AVC to ground.

NOTE: For calibrating both the AM and FM, use as low an output voltage as possible from your signal generator.

STEPS	CHASSIS		SIGNAL GENERATOR			INDICATOR		ALIGNMENT	
	SELECTOR	STATION SELECTOR	COUPLING	FREQ.	MOD.	TYPE	CONNECTION	ADJUST	INDICATION
1	AM	Point of no signal and no interference	AM Gen. to ungrounded tube shield over V3	455 KC	30% AM at 400 cps	AC VTVM	to Left Rec. Output	Z2, Z4 top and bottom	Maximum voltage
2	AM	600 KC	AM Gen. connected thru 220-uuf to the AM antenna terminal. Disconnect link between terminals.	600 KC	30% AM at 400 cps	AC VTVM	to Left Rec. Output	L9, L4, L1	Maximum voltage
3	AM	1400 KC	AM Gen. connected thru 220-uuf to the AM antenna terminal. Disconnect link between terminals.	1400 KC	30% AM at 400 cps	AC VTVM	to Left Rec. Output	C5H, C5E, CSC	Maximum voltage
4	Repeat steps 2 and 3 for proper dial calibration and maximum output, using lowest possible generator output.								
1	FM	Point of no signal and no interference	FM Gen. connected to ungrounded tube shield of V1	10.7 MC	None	DC VTVM	to test point 3	Z1, Z3, Z6 top & bottom, Z5 top	Maximum negative voltage
2	FM	Point of no signal and no interference	FM Gen. connected to ungrounded tube shield of V1	10.7 MC	None	Connect hot lead of DC VTVM to MPX output, ground to junction of resistors (47K) connected in series from TSP3 to GND.		Z6, top	Zero reading on zero center scale
3	FM	90 MC	FM Gen. connected thru two 120-ohm carbon resistors in series with lead to antenna terminals DISTANCE.	90 MC	30% FM (22.5 KC Dev.) at 400 cps	DC VTVM	to TSP3 and scope to Ch. A. Rec. output	L8, L6 and L2	Check for sine waveform and adjust for maximum negative voltage
4	FM	106 MC	FM Gen. connected thru two 120-ohm carbon resistors in series with lead to antenna terminals DISTANCE.	106 MC	30% FM (22.5 KC Dev.) at 400 cps	DC VTVM	to TSP3 and scope to Ch. A. Rec. output	C28, C17	Check for sine waveform and adjust for maximum negative voltage
5	Repeat steps 3 and 4 for proper dial calibration and maximum output.								

AM ALIGNMENT

FM ALIGNMENT

SCHEMATIC DIAGRAM

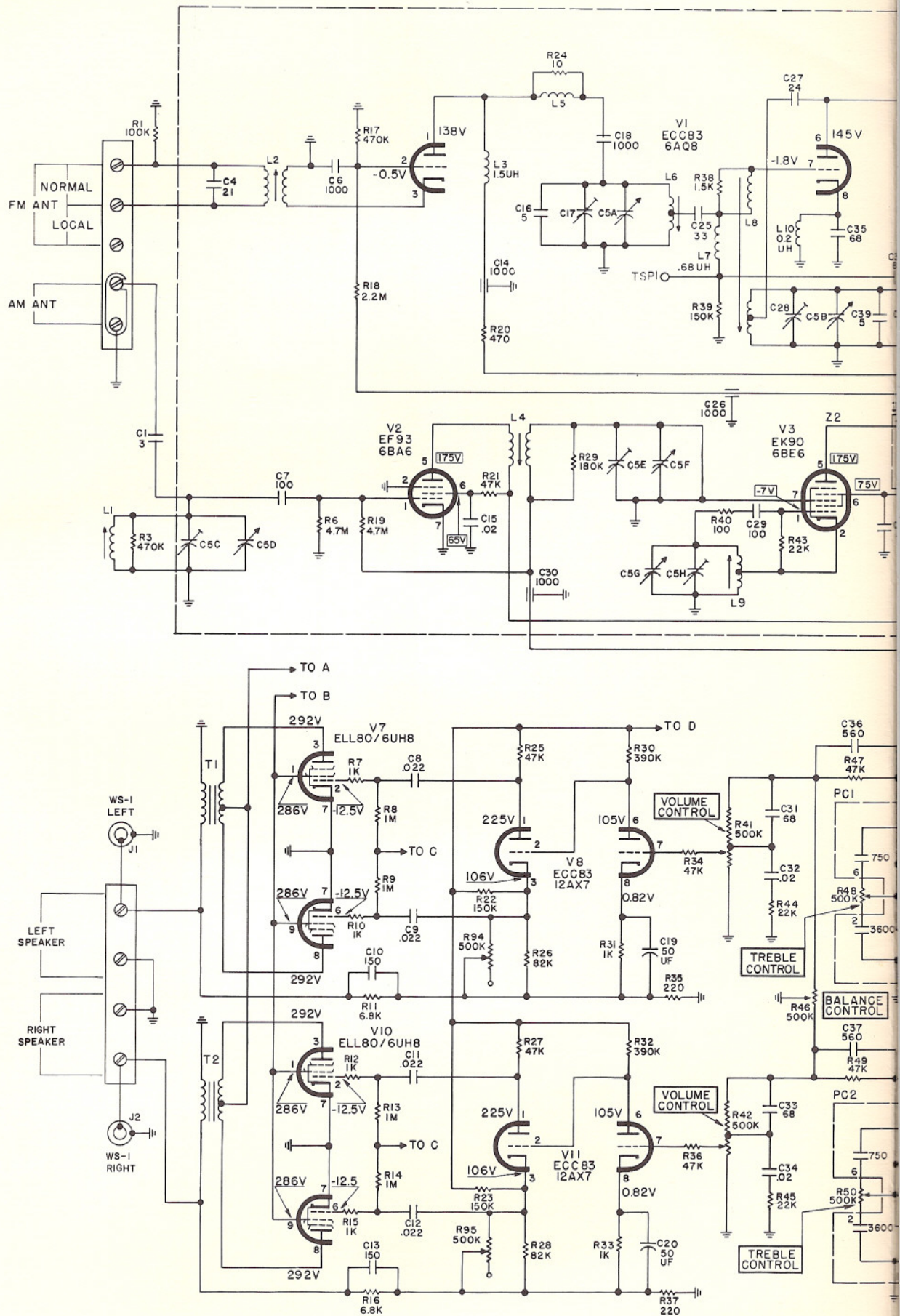

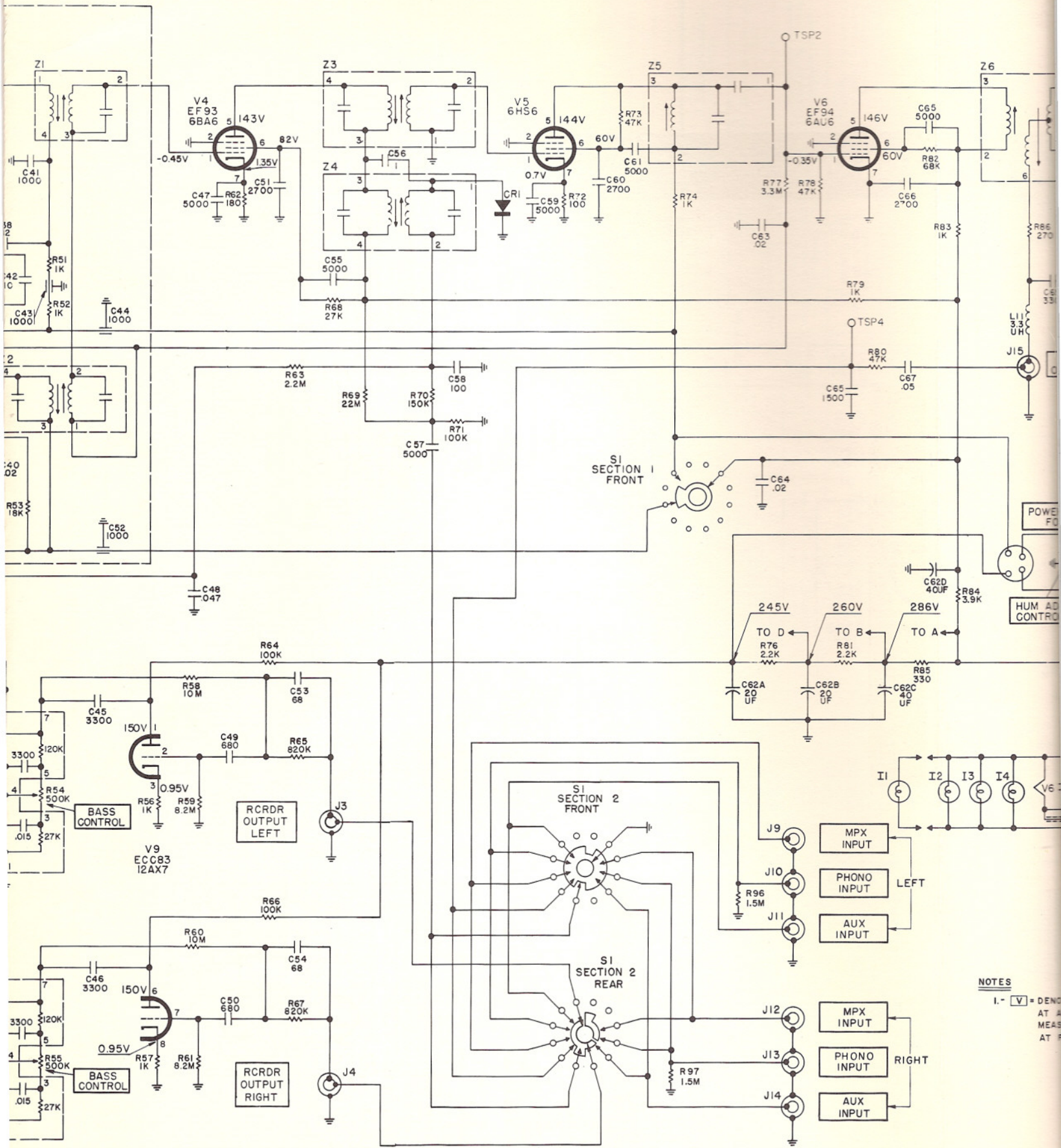

NOTES

1. [V] = DENC AT MEAS AT F

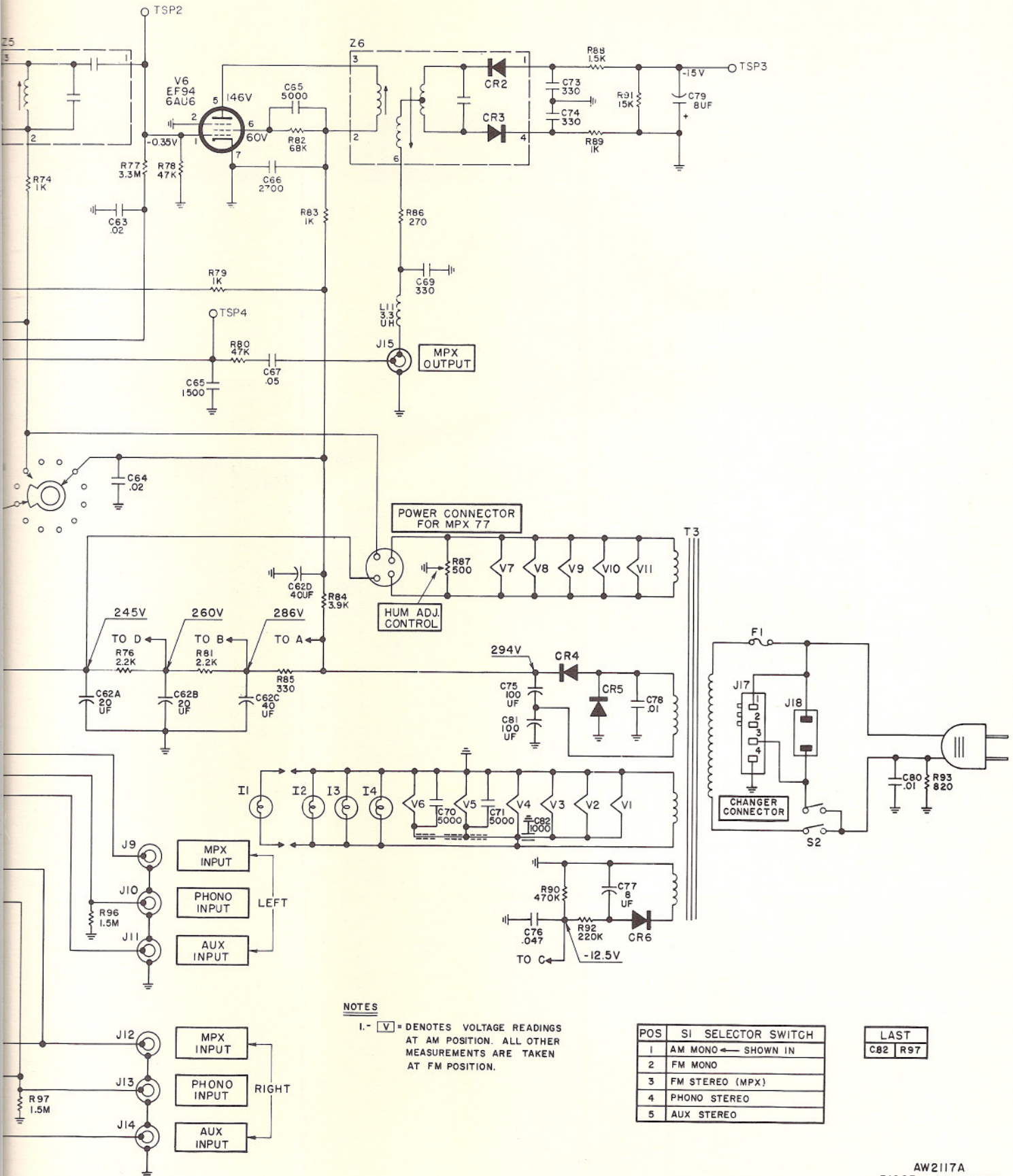

NOTES

I. - [V] = DENOTES VOLTAGE READINGS AT AM POSITION. ALL OTHER MEASUREMENTS ARE TAKEN AT FM POSITION.

POS	SI SELECTOR SWITCH
1	AM MONO ← SHOWN IN
2	FM MONO
3	FM STEREO (MPX)
4	PHONO STEREO
5	AUX STEREO

LAST	
C82	R97

SCHEMATIC DIAGRAM • MULTIPLEX

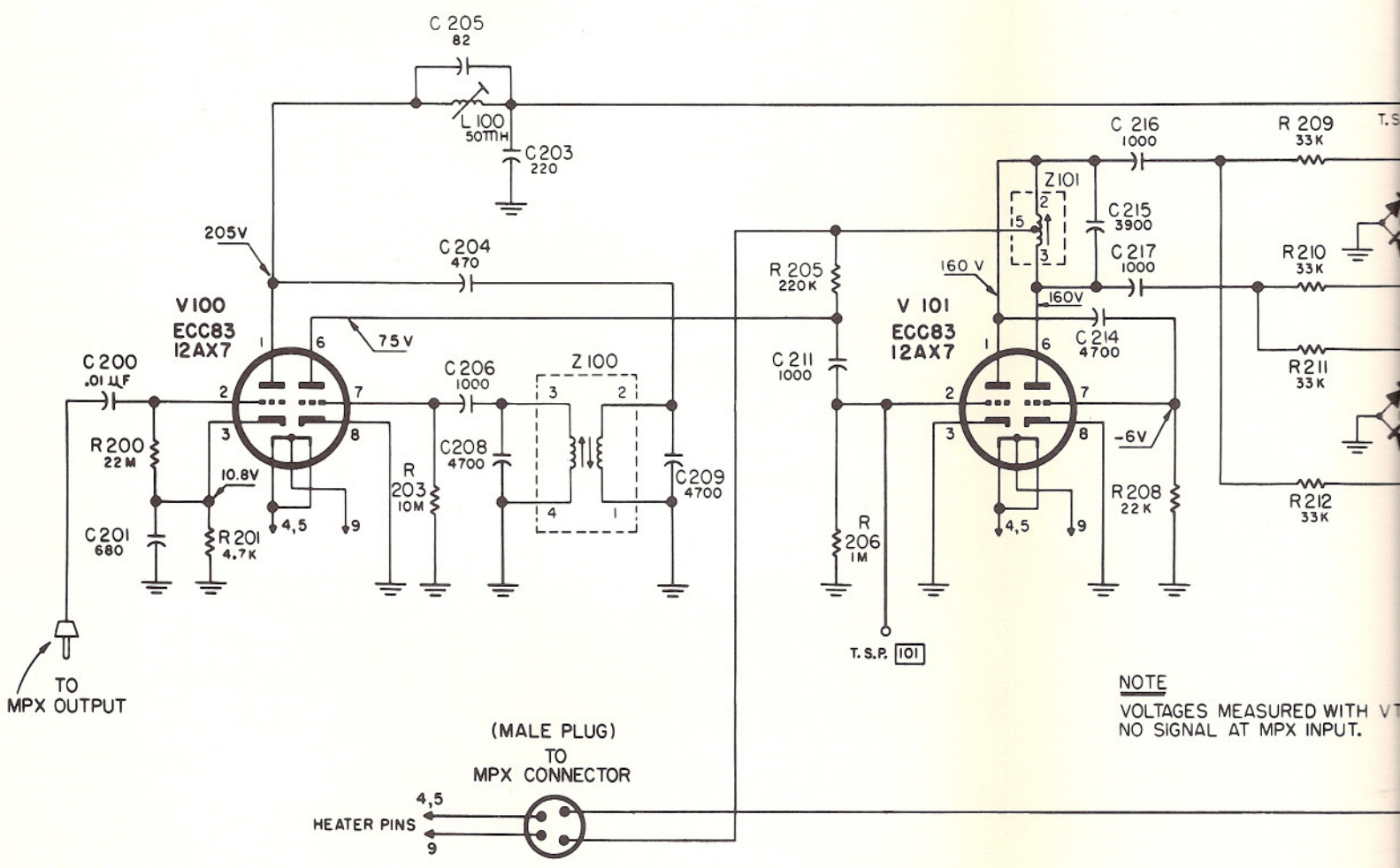

NOTE
VOLTAGES MEASURED WITH VT
NO SIGNAL AT MPX INPUT.

MATIC DIAGRAM • MULTIPLEX SECTION

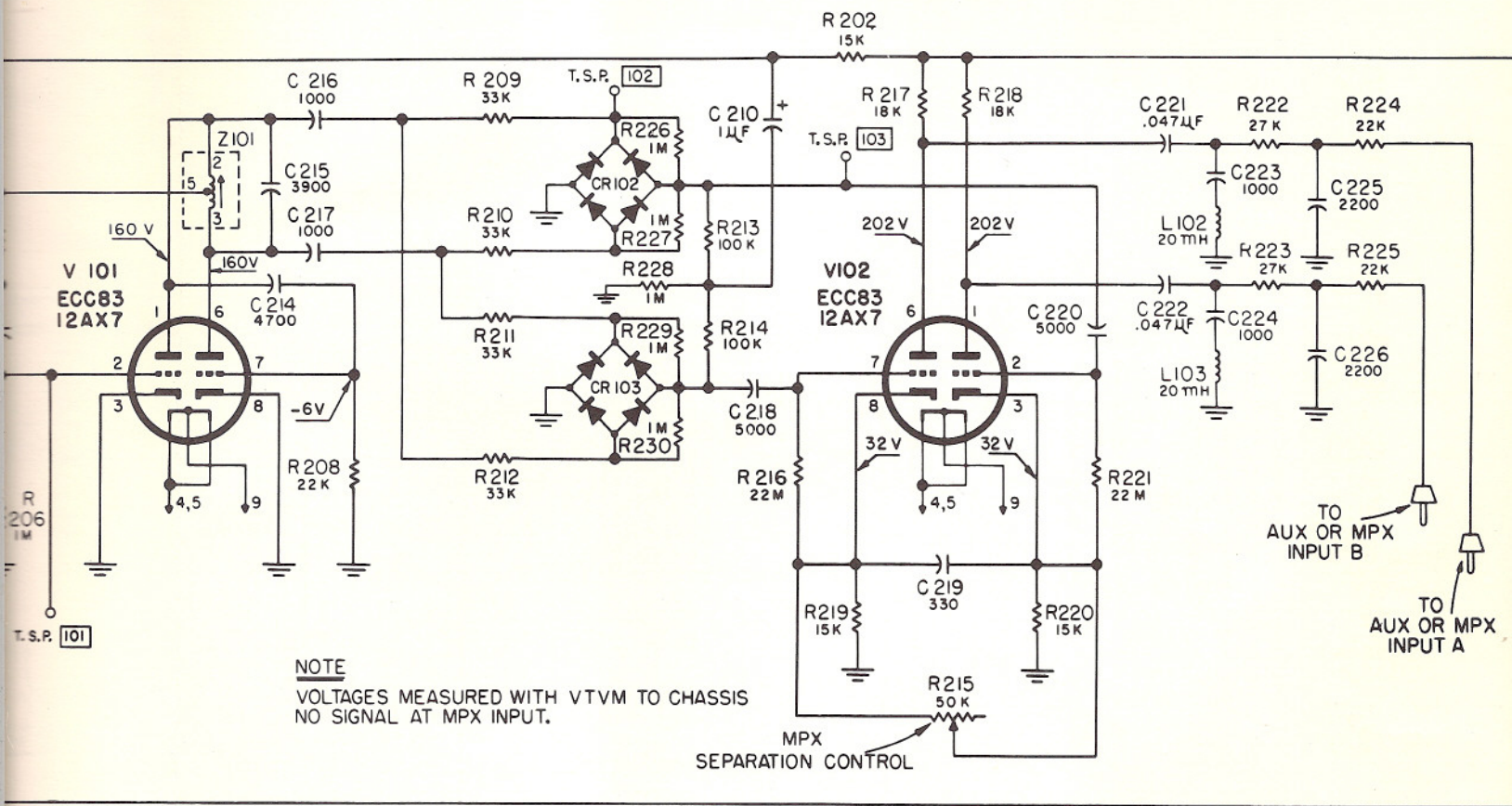

SCHEMATIC DIAGRAM • SPEAKER SYSTEMS

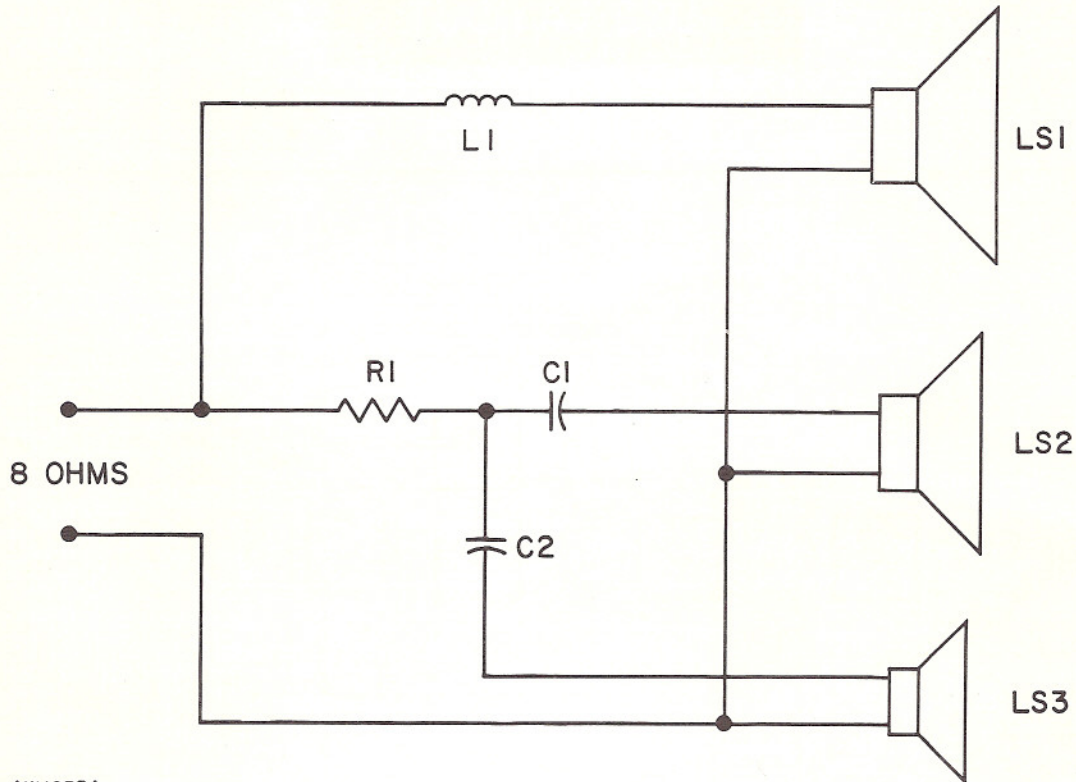

AW 1833A

PARTS DESCRIPTION LIST • SPEAKER SYSTEMS

Symbol	Description	Part No.
C1	Electrolytic, Non-polarized, 20uf, 250V	C547-119
C2	Paper, 2uf, 50V	C547-118
LS1	Woofer, 8", 8 ohms	LS839-102
LS2	Midrange, 4 x 6", 8 ohms	LS839-103
LS3	Tweeter, 3", 8 ohms	LS834-104
R1	Wirewound, 6.8, 5W	R671-113
L1	Coil, 1.5-mh	L832-108

TUBE LAYOUT

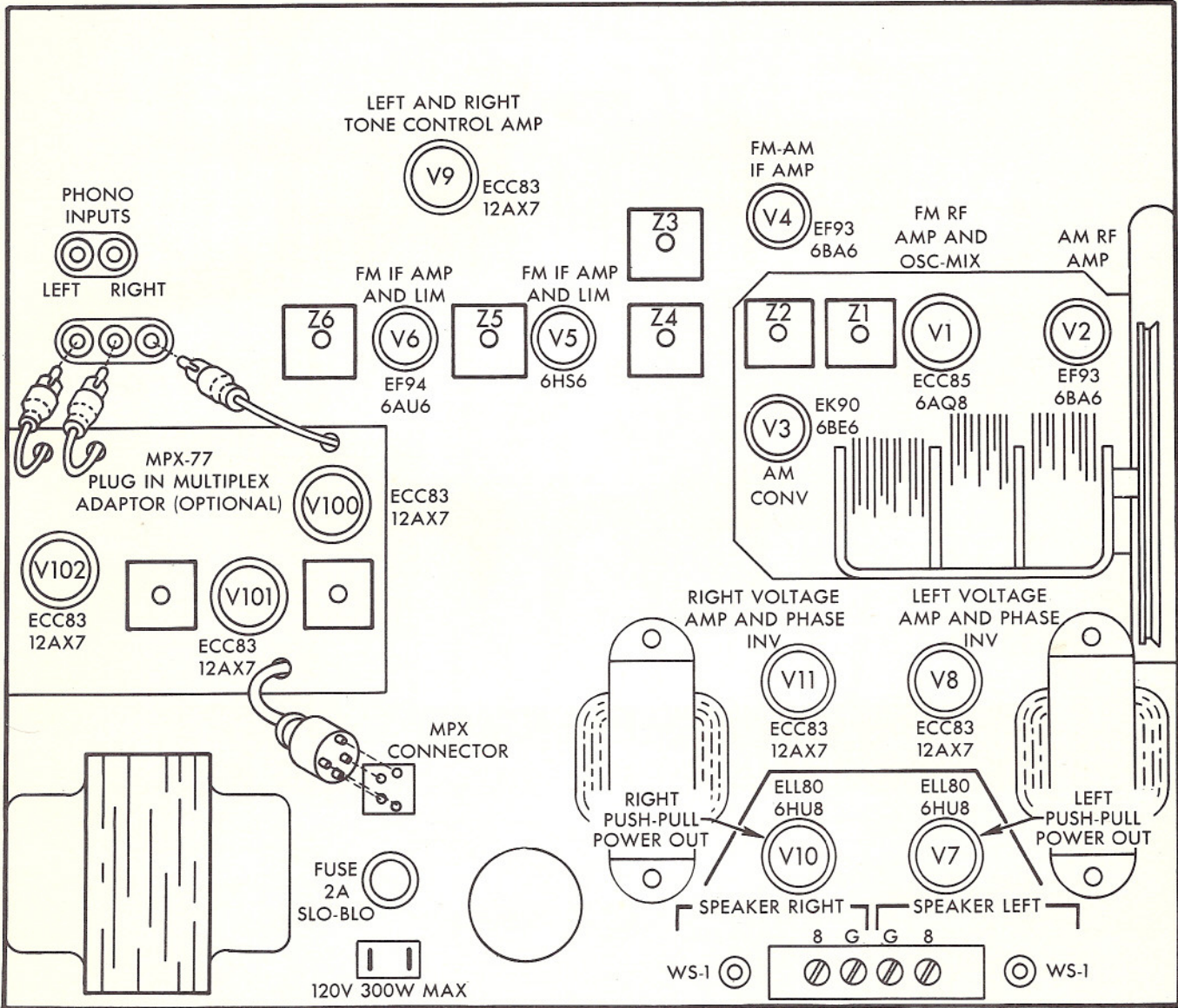

SERVICE NOTES



FISHER RADIO CORPORATION • NEW YORK

N 1059-103

© 1963 FISHER RADIO CORPORATION

PRINTED IN U S A

670-W22C-53