

*Stereophonic*

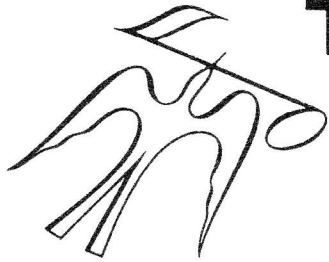

# THE FISHER

# PREMIERE SCHEMATIC and PARTS LIST

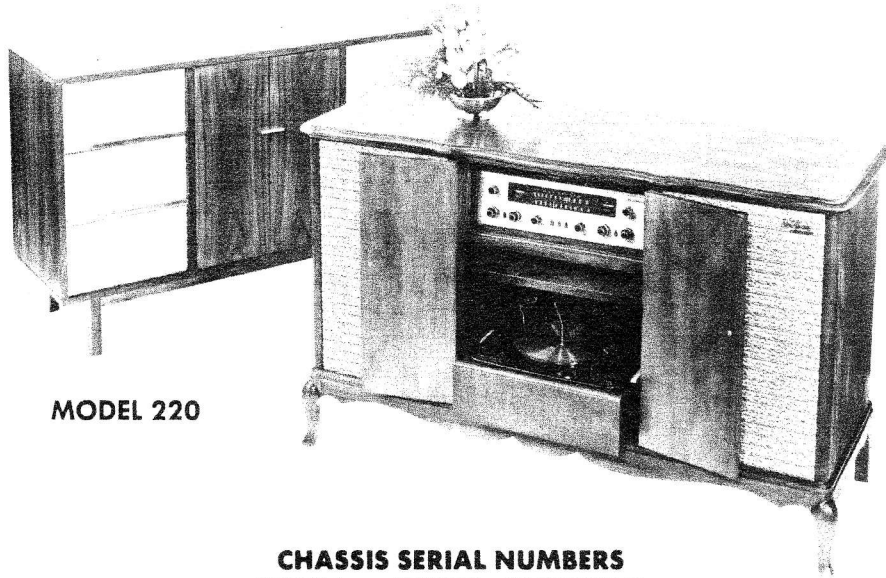

MODEL 220

CHASSIS SERIAL NUMBERS  
20001 — 29999 INCLUSIVE

PRICE: \$1.00

FISHER RADIO CORPORATION • NEW YORK



CHASSIS SERIAL NUMBERS  
20001 — 29999 INCLUSIVE

THE FISHER 220



# PARTS DESCRIPTION LIST • RECEIVER CHASSIS

## CAPACITORS

10% tolerance for all fixed capacitors, unless otherwise noted or marked GMV (guaranteed minimum value.)

Symbol	Description	Part No.
C1	Ceramic, 24uuf 5% N150, 1000V	C50070-8
C2	Ceramic, 100uuf N1500, 1000V	C50070-6
C3, 4	Ceramic, 8uuf ±.5uuf NPO, 500V	CC20CJ080D5
C5	Ceramic, Trimmer	C662-123
C6	AM Variable	Part of C9
C7	Ceramic, 100uuf N1500, 1000V	C50070-6
C8	FM Variable	C726-116
C9	AM Variable	C684-127
C10	Ceramic, Feedthru, .001uf GMV	C592-187
C11	Ceramic, 100uuf N1500, 1000V	C50070-6
C12	Molded, .047uf, 250V	C50074-27
C13	Ceramic, .001uf, 1000V	C50072-3
C14	Ceramic, Feedthru, .001uf GMV	C592-187
C15	Ceramic, 5uuf ±.5uuf NPO, 500V	CC20CJ050D5
C16	Ceramic, Trimmer	C662-123
C17	Ceramic, .02uf +80—20%, 500V	C50089-4
C18	Molded, .01uf 20%, 600V	C2747
C19	Ceramic, 100uuf N1500, 1000V	C50070-6
C20	Ceramic, .02uf +80—20%, 500V	C50089-4
C21	Ceramic, 68uuf N750, 500V	CC20UJ680K5
C22	Ceramic, 100uuf N1500, 1000V	C50070-6
C23	Ceramic, 18uuf N470, 1000V	C50070-13
C24	Ceramic, .005uf 20%, 500V	C50089-1
C25	Ceramic, 5uuf ±.5uuf N220, 500V	CC20RH050D5
C26	Ceramic, Trimmer	C662-123
C27	Ceramic, .68uuf 20%, 500V	C50077-6N
C28	Ceramic, Feedthru, .001uf GMV	C592-187
C29	Ceramic, 24uuf 5% N150, 1000V	C50070-8
C30	Ceramic, 100uuf, N1500, 1000V	C50070-19
C31	Ceramic, 10uuf ±.5uuf NPO, 500V	CC20CH100D5
C32	Ceramic, .001uf, 1000V	C50072-3
C33	AM Variable	Part of C9
C34	Ceramic, 100uuf N1500, 1000V	C50070-6
C35	Ceramic, .005uf 20%, 500V	C50089-1
C36	Ceramic, 2.2uuf, 500V	C3039
C37	Electrolytic, four section: A: 40uf, 400V B: 40uf, 350V C: 20uf, 300V D: 20uf, 300V	C50180-2
C38	Ceramic, Feedthru, .001 GMV	C592-187
C39	Electrolytic, three section: A: 40uf, 300V B: 40uf, 250V C: 40uf, 250V	C670-125
C40	Ceramic, Feedthru, .001uf GMV	C592-187
C41	Ceramic, .02uf +80—20%, 500V	C50089-4
C42	Ceramic, 100uuf N1500, 1000V	C50070-6
C43	Ceramic, .02uf +80—20%, 500V	C50089-4
C44	Ceramic, .001uf, 1000V	C50072-3
C45	Ceramic, .005uf 20%, 500V	C50089-1
C46	Ceramic, .0027uf, 1000V	C50072-17
C47	Ceramic, .02uf +80—20%, 500V	C50089-4
C48	Ceramic, Feedthru, .001uf GMV	C592-187
C49	Ceramic, .005uf 20%, 500V	C50089-1
C50	Ceramic, 10uuf NPO, 1000V	C50070-11
C51	AM Variable	Part of C9
C52	Ceramic, .02uf +80—20%, 500V	C50089-4
C53	Ceramic, Feedthru, .001uf GMV	C592-187
C54	Ceramic, .02uf +80—20%, 500V	C50089-4
C55, 56	Ceramic, .005uf 20%, 500V	C50089-1
C57	Ceramic, .0027uf, 1000V	C50072-17
C58	Ceramic, .02uf +80—20%, 500V	C50089-4
C59	Ceramic, 10uuf NPO, 1000V	C50070-11
C60	Ceramic, .005uf 20%, 500V	C50089-1
C61	Ceramic, .0027uf, 1000V	C50072-17
C62, 63	Ceramic, .005uf 20%, 500V	C50089-1
C64, 65	Ceramic, 330uuf, 1000V	C50072-1
C66	Electrolytic, 8uf, 50V	C629-138
C67	Ceramic, .055uf 20%, 500V	C50089-1
C68	Ceramic, 330uuf, 1000V	C50072-1
C69	Ceramic, .01uf 20%, 500V	C50089-3
C70	Ceramic, .001uf, 1000V	C50072-3
C71	Molded, .022uf, 250V	C50074-26
C72	Ceramic, 820uuf 5%, 500V	CC21GP821J5
C73	Ceramic, 220uuf, 1000V	C50072-20
C74	Molded, .047uf, 250V	C50074-27
C75	Ceramic, .01uf 20%, 500V	C50089-3
C76, 77	Ceramic, .02uf +80—20%, 500V	C50089-4
C78	Ceramic, .01uf 20%, 500V	C50089-3
C79	Ceramic, 16uuf N75, 1000V	C50070-21

## C80

Electrolytic, four section:

Symbol	Description	Part No.
	A: 10uf, 200V	
	B: 10uf, 200V	
	C: 30uf, 300V	
	D: 30uf, 300V	
C81, 82	Ceramic, .01uf 20%, 500V	C50089-3
C83	Ceramic, 16uuf N75, 1000V	C50070-21
C84, 85	Ceramic, .01uf 20%, 500V	C50089-3
C86, 87	Electrolytic, 25uf, 6V	C639-114
C88	Ceramic, .001uf, 1000V	C50072-3
C89	Molded, .01uf, 250V	C50074-25
C90, 91	Ceramic, 390uuf, 1000V	C50072-6
C92	Ceramic, .001uf, 1000V	C50072-3
C93	Molded, .01uf, 250V	C50074-25
C94	Ceramic, 220uuf, 1000V	C50072-20
C95, 96	Ceramic, 560uuf, 1000V	C50072-14
C97	Ceramic, 220uuf, 1000V	C50072-20
C98	Ceramic, .0033uf, 1000V	C50072-11
C99, 100	Ceramic, .0018uf, 1000V	C50072-8
C101	Ceramic, .0033uf, 1000V	C50072-11
C102, 103	Molded, .022uf, 250V	C50074-26
C104, 105	Ceramic, 47uuf N750, 1000V	C50070-4
C106, 107	Ceramic, 220uuf, 1000V	C50072-20
C108	Molded, .01uf, 250V	C50074-25
C109	Ceramic, 100uuf N1500, 1000V	C50070-6
C110	Molded, .01uf, 250V	C50074-25
C111, 112, 113	Ceramic, 100uuf N1500, 1000V	C50070-6
C114	Molded, .002uf, 200V	C68P202K2
C115	Ceramic, .001uf, 1000V	C50072-3
C116	Molded, .002uf, 200V	C68P202K2
C117	Ceramic, .001uf, 1000V	C50072-3
C118, 119	Electrolytic, 25uf, 6V	C639-114
C120, 121	Ceramic, 100uuf N1500, 1000V	C50070-6
C122	Molded, .1uf, 500V	C50074-38
C123, 124	Ceramic, 68uuf N2200, 1000V	C50070-12
C125	Molded, .1uf, 500V	C50074-38
C126	Ceramic, 47uuf N750, 1000V	C50070-4
C127	Ceramic, 15uuf N75, 1000V	C50070-18
C128	Electrolytic, 25uf, 6V	C639-114
C129	Ceramic, 470uuf, 1000V	C50072-13
C130, 131	Molded, .022uf, 250V	C50074-26
C132	Ceramic, 47uuf N750, 1000V	C50070-4
C133	Ceramic, 15uuf N75, 1000V	C50070-18
C134	Electrolytic, 25uf, 6V	C639-114
C135	Ceramic, 470uuf, 1000V	C50072-13
C136, 137, 138, 139	Molded, .1uf, 20%, 500V	C50074-38
C140, 141, 142, 143	Ceramic, 390uuf, 1000V	C50072-6
C144	Electrolytic, 100uf, 100V	C663-143
C145	Ceramic, 5uuf ±.5uuf N150, 500V	CC20PJ050D5
C146	Ceramic, 47uuf N750, 1000V	C50070-6
C147	Ceramic, 82uuf N1500, 1000V	C50070-7
C148	Ceramic, 68uuf N2200, 1000V	C50070-12
C149	Ceramic, .005uuf 20% 500V	C50089-1

## RESISTORS AND POTENTIOMETERS

In ohms, 10% tolerance, 1/2 watt, unless otherwise noted. K = kilohm, M = megohm.

Symbol	Description	Part No.
R1	Composition, 270	RC20BF271K
R2	Composition, 1K	RC20BF102K
R3	Composition, 4.7	RC20BF4R7K
R4, 5	Composition, 330K	RC20BF334K
R6	Composition, 100K	RC20BF104K
R7, 8	Composition, 2.2M	RC20BF225K
R9	Composition, 100	RC20BF101K
R10	Composition, 22	RC20BF220K
R11	Composition, 2.2K	RC20BF222K
R12	Composition, 47K	RC20BF473K
R13	Composition, 1K	RC20BF102K
R14	Not Used	Not Used
R15	Composition, 470K	RC20BF474K
R16	Composition, 1K	RC20BF102K
R17	Composition, 4.7	RC20BF4R7K
R18	Composition, 820K	RC20BF824K
R19	Wirewound, 140, 10W	R720-177
R20	Potentiometer, Wirewound, 500	R516-128
R21	Wirewound, 50, 5W	R556-142
R22	Potentiometer, Wirewound, 500	R516-128
R23	Composition, 100	RC20BF101K
R24	Composition, 150	RC20BF151K
R25	Wirewound, 220, 5W	R551-137
R26	Wirewound, 2200, 7W	R563-148
R27	Composition, 47K	RC20BF473K

# PARTS DESCRIPTION LIST • RECEIVER CHASSIS

**R28** Wirewound, 220, 5W  
**R29** Composition, 68K  
**R30** Composition, 1M  
**R31** Composition, 33K, 1W  
**R32** Composition, 1K  
**R33** Composition, 1K, 1W  
**R34** Composition, 3.3M  
**R35** Composition, 22K, 1W  
**R36** Composition, 100  
**R37** Composition, 1K  
**R38** Composition, 270  
**R39** Composition, 47K  
**R40** Composition, 270  
**R41** Composition, 1K  
**R42** Composition, 33K  
**R43** Composition, 180  
**R44, 45** Composition, 2.2M  
**R46** Composition, 82K  
**R47** Composition, 470K  
**R48** Composition, 1K  
**R49** Composition, 47K, 1W  
**R50** Composition, 47K  
**R51** Composition, 1K  
**R52** Composition, 270  
**R53** Composition, 10M  
**R54** Composition, 390K  
**R55** Composition, 330K  
**R56** Composition, 470K  
**R57** Composition, 1K  
**R58** Composition, 68K  
**R59** Composition, 100K  
**R60** Composition, 3.3M  
**R61** Potentiometer, 250K  
**R62** Composition, 15K  
**R63** Composition, 1.5K  
**R64, 65**  
**66, 67** Potentiometer, 250K  
**R68, 69** Composition, 220K  
**R70, 71** Composition, 10M  
**R72** Composition, 47K  
**R73** Composition, 15M  
**R74** Composition, 2.2M  
**R75** Composition, 3.3M  
**R76** Composition, 330K, 1W  
**R77** Composition, 2.7K, 1W  
**R78** Composition, 10  
**R79** Composition, 330K, 1W  
**R80** Composition, 2.7K, 1W  
**R81** Composition, 10  
**R82** Composition, 47K  
**R83** Composition, 15M  
**R84** Composition, 2.2M  
**R85** Composition, 3.3M  
**R86** Composition, 100K  
**R87** Composition, 1.2K  
**R88** Composition, 10K  
**R89** Composition, 100K  
**R90** Composition, 10K  
**R91, 92** Composition, 100K  
**R93** Composition, 1.2K  
**R94** Potentiometer, Dual Bass, 1M  
**R95** Composition, 220K  
**R96** Composition, 39K  
**R97** Composition, 18K  
**R98** Composition, 270K  
**R99** Composition, 2.2M  
**R100** Composition, 270K  
**R101** Composition, 2.2M  
**R102** Composition, 220K  
**R103** Composition, 39K  
**R104** Composition, 18K  
**R105** Potentiometer, Dual Treble, 1M  
**R106, 107** Composition, 120K  
**R108, 109** Composition, 470K  
**R110** Composition, 10M  
**R111** Composition, 4.7M  
**R112** Composition, 100K  
**R113** Composition, 10M  
**R114** Composition, 4.7M  
**R115, 116** Composition, 100K  
**R117** Composition, 10M  
**R118** Composition, 100K  
**R119** Composition, 10M  
**R120, 121** Composition, 2.2M  
**R122, 123** Composition, 220K  
**R124** Composition, 2.2K

**R551-137**  
**RC20BF683K**  
**RC20BF105K**  
**RC30BF333K**  
**RC20BF102K**  
**RC30BF102K**  
**RC20BF335K**  
**RC30BF223K**  
**RC20BF101K**  
**RC20BF102K**  
**RC20BF271K**  
**RC20BF473K**  
**RC20BF271K**  
**RC20BF102K**  
**RC20BF333K**  
**RC20BF181K**  
**RC20BF225K**  
**RC20BF823K**  
**RC20BF474K**  
**RC20BF102K**  
**RC30BF473K**  
**RC20BF473K**  
**RC20BF102K**  
**RC20BF271K**  
**RC20BF106K**  
**RC20BF394K**  
**RC20BF334K**  
**RC20BF474K**  
**RC20BF102K**  
**RC20BF683K**  
**RC20BF104K**  
**RC20BF335K**  
**R50160-3**  
**RC20BF153K**  
**RC20BF152K**

**R50160-3**  
**RC20BF224K**  
**RC20BF106K**  
**RC20BF473K**  
**RC20BF156K**  
**RC20BF225K**  
**RC20BF335K**  
**RC30BF334K**  
**RC30BF272K**  
**RC20BF100K**  
**RC30BF334K**  
**RC30BF272K**  
**RC20BF100K**  
**RC20BF473K**  
**RC20BF156K**  
**RC20BF225K**  
**RC20BF335K**  
**RC20BF104K**  
**RC20BF122K**  
**RC20BF103K**  
**RC20BF104K**  
**RC20BF103K**  
**RC20BF104K**  
**RC20BF122K**  
**R50160-19**  
**RC20BF224K**  
**RC20BF393K**  
**RC20BF183K**  
**RC20BF274K**  
**RC20BF225K**  
**RC20BF274K**  
**RC20BF225K**  
**RC20BF224K**  
**RC20BF393K**  
**RC20BF183K**  
**R50160-19**  
**RC20BF124K**  
**RC20BF474K**  
**RC20BF106K**  
**RC20BF475K**  
**RC20BF104K**  
**RC20BF106K**  
**RC20BF475K**  
**RC20BF104K**  
**RC20BF106K**  
**RC20BF104K**  
**RC20BF106K**  
**RC20BF104K**  
**RC20BF106K**  
**RC20BF225K**  
**RC20BF224K**  
**RC20BF393K**  
**RC20BF183K**  
**R50160-19**  
**RC20BF124K**  
**RC20BF474K**  
**RC20BF106K**  
**RC20BF475K**  
**RC20BF104K**  
**RC20BF106K**  
**RC20BF475K**  
**RC20BF104K**  
**RC20BF106K**  
**RC20BF104K**  
**RC20BF106K**  
**RC20BF225K**  
**RC20BF224K**  
**RC20BF222K**

**R125, 126** Composition, 100K  
**R127** Composition, 2.2K  
**R128** Potentiometer, Dual Balance, 250K  
**R129, 130** Composition, 47K  
**R131** Composition, 4.7K  
**R132** Potentiometer, Dual Volume, 500K  
**R133** Composition, 4.7K  
**R134, 135** Composition, 820K  
**R136** Composition, 220K  
**R137** Composition, 1.5K  
**R138** Composition, 100  
**R139** Composition, 6.8K  
**R140** Composition, 220K  
**R141** Composition, 1.5K  
**R142** Composition, 100  
**R143** Composition, 6.8K  
**R144, 145** Composition, 33K, 1W  
**R146, 147** Composition, 22K  
**R148, 149** Composition, 33K, 1W  
**R150, 151** Composition, 680K  
**R152** Composition, 10K  
**R153, 154** Composition, 680K  
**R155** Composition, 10K  
**R156** Composition, 4.7K, 1W  
**R157** Composition, 1K  
**R158, 159** Composition, 15K  
**R160** Composition, 1K  
**R161** Composition, 4.7K, 1W  
**R162, 163** Composition, 1K  
**RC20BF104K**  
**RC20BF222K**  
**R50160-18**  
**RC20BF473K**  
**RC20BF472K**  
**R50160-17**  
**RC20BF472K**  
**RC20BF824K**  
**RC20BF224K**  
**RC20BF152K**  
**RC20BF101K**  
**RC20BF682K**  
**RC20BF224K**  
**RC20BF152K**  
**RC20BF101K**  
**RC20BF682K**  
**RC30BF333K**  
**RC20BF223K**  
**RC30BF333K**  
**RC20BF684K**  
**RC20BF103K**  
**RC20BF684K**  
**RC20BF103K**  
**RC30BF472K**  
**RC20BF102K**  
**RC20BF153K**  
**RC20BF102K**  
**RC30BF472K**  
**RC20BF102K**

## COILS, CHOKES AND TRANSFORMERS

Symbol	Description	Part No.
L1	Choke, 3.3 Micro Henries	L50066-8
L2	Coil, FM Antenna	L726-124
L3	Coil, AM Antenna	L721-139
L4	AM Ferrite Loop	L721-136
L5	Choke, 1 Micro Henry	L50066-2
L6, 7	Choke, .56 Micro Henries	L50066-19
L8	Choke, RF	L629-180
L9	Coil, FM RF	L726-126
L10	Coil, FM Oscillator	L726-125
L11, 13	Choke, 1 Micro Henry	L50066-2
L12	Choke, .56 Micro Henries	L50066-19
L14	Choke, 1.2 Micro Henries	L50066-3
L15, 16, 17, 18	Choke, Filament Ferrite Bead	L592-189
L19	Coil, AM Oscillator	L50210-21
L20	Choke, 1.2 Micro Henries	L50066-3
L21	Coil, 10kc Filter	L644-120
T1	Transformer, Power	T720-115
T2, 3	Transformer, Output	T720-116
Z1	Transformer, FM IF	ZZ662-117
Z2	Transformer, FM IF	ZZ2987
Z3	Limiter Coil Assembly	L670-145
Z4	Transformer, FM Detector	ZZ592-170
Z5	Transformer, AM RF	L556-125
Z6	Transformer, AM IF	ZZ50210-1
Z7	Transformer, AM IF	ZZ2984

## MISCELLANEOUS

Symbol	Description	Part No.
F1	Fuse, 3.2 Ampere, Slo-Blo	F3319
I1, 2	Lamp, Dial Panel	I-50082-3
S1	Switch, Selector	S720-154
S2	Switch, Mono-Stereo	S720-151
S3	Switch, Slide	S50200-2
S4	Switch, Power	Part of R132
S5, 6, 7, 8, 9	Switch, Slide	S50200-2

## MECHANICAL PARTS

Symbol	Description	Part No.
—	FM Dial Pointer	A720-158
—	AM Dial Pointer	A720-159
—	Knob, Tuning	E50133-1
—	Knob, Selector and Mono-Stereo	E50133-2
—	Knob, Bass and Treble, Rear	E50153-1
—	Knob, Bass and Treble, Front	E50152
—	Knob, Volume and Balance	E50154-1
—	9-Pin Tube Shield	E3287
—	7-Pin Tube Shield	E3330
—	Speaker Terminal Strip	E50170-10
—	Plastic Leg	H657-145
—	Dial Glass	N720-113
—	Fuse Holder	X1036

# SCHEMATIC DIAGRAM • AMPLIFIER SECTION OF RECEIVER CHASSIS

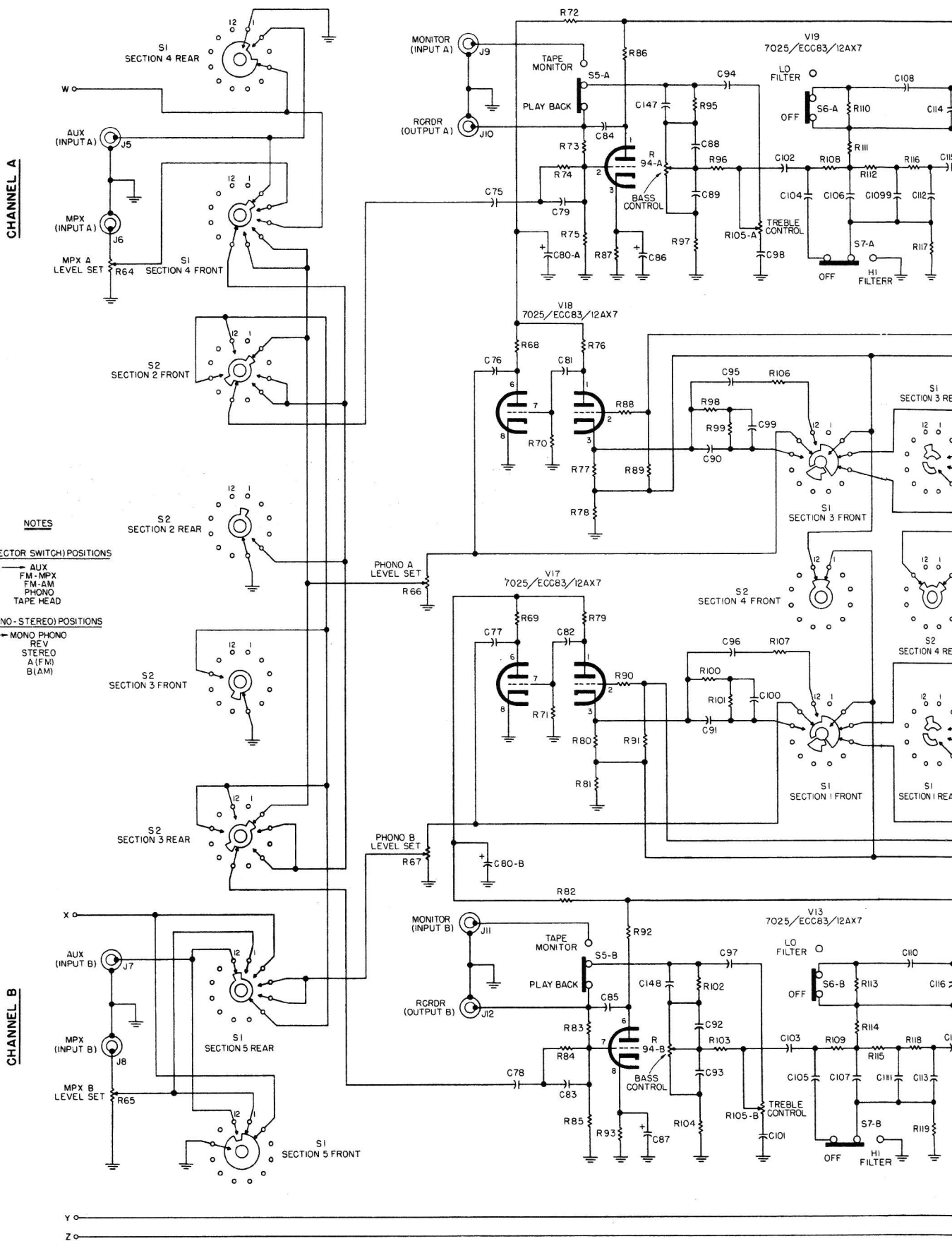

**NOTES**

**S1 (SELECTOR SWITCH) POSITIONS**  
 SHOWN IN → AUX  
 FM-MPX  
 FM-AM  
 PHONO  
 TAPE HEAD

**S2 (MONO-STEREO) POSITIONS**  
 SHOWN IN → MONO PHONO  
 REV  
 STEREO  
 A (FM)  
 B (AM)

# CHASSIS

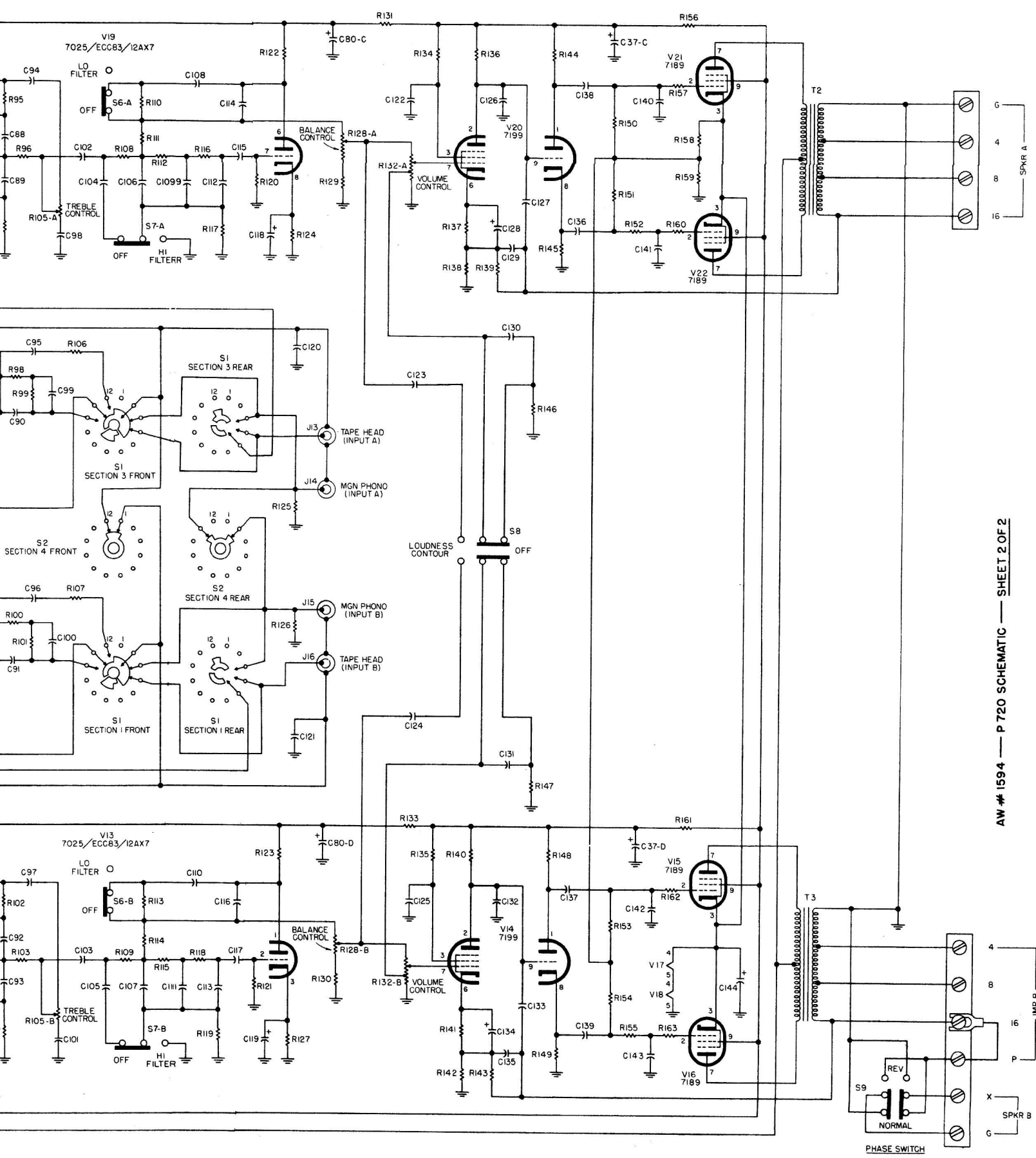

# SCHEMATIC DIAGRAM • TUNER SECTION OF RECEIVER CHASSIS

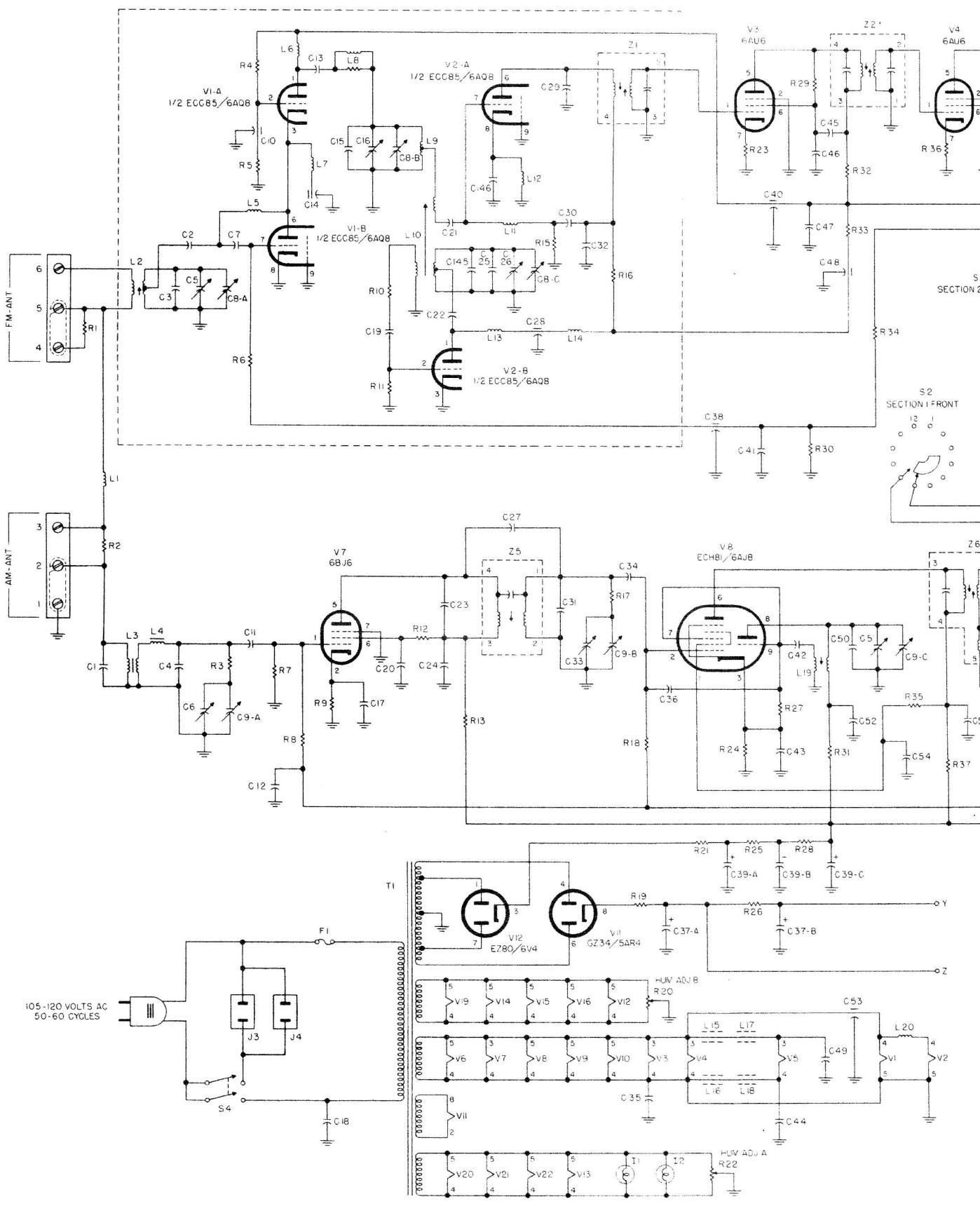

# RECEIVER CHASSIS

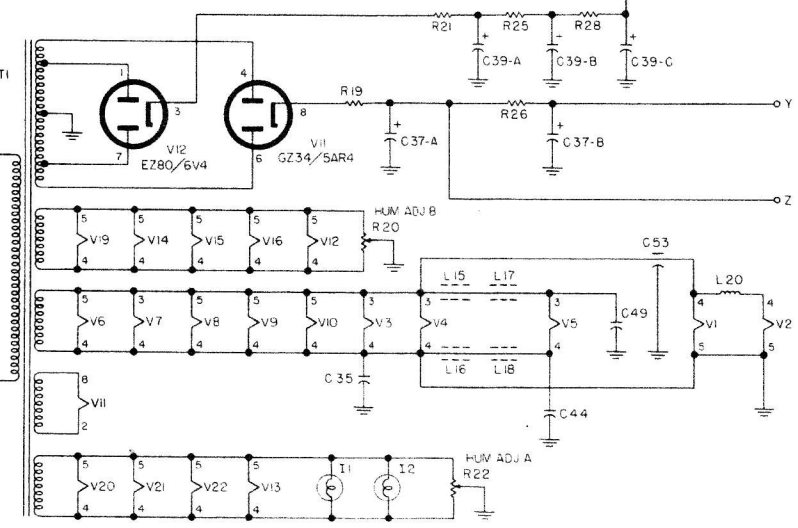
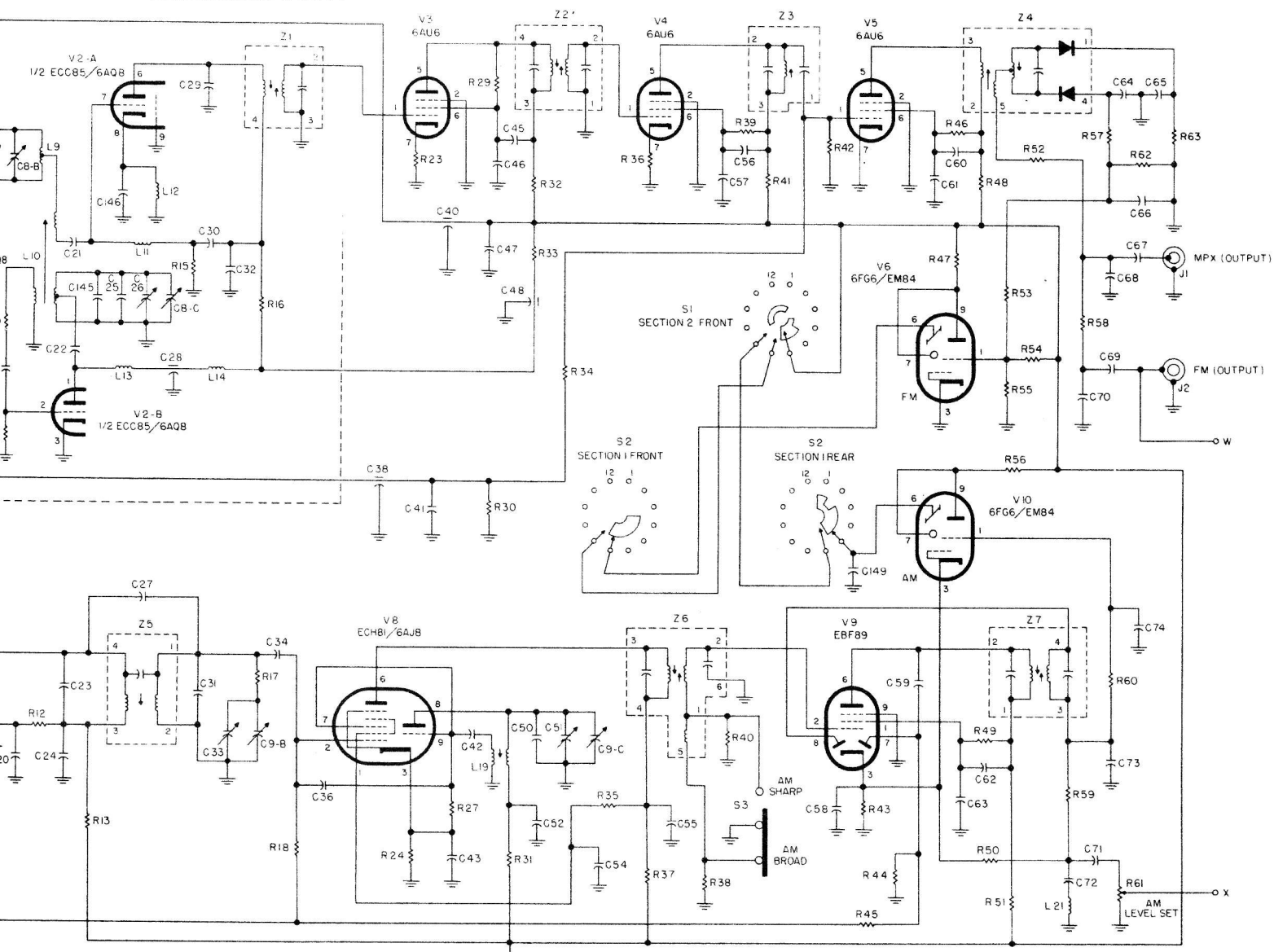

### NOTES

- S1 (SELECTOR SWITCH) POSITIONS**  
 SHOWN IN → AUX  
 FM-MPX  
 FM-AM  
 PHONO  
 TAPE HEAD
- S2 (MONO-STEREO) POSITIONS**  
 SHOWN IN → MONO PHONO  
 RE V  
 STEREO  
 A (FM)  
 B (AM)

## SCHEMATIC DIAGRAM • SPEAKER SYSTEMS

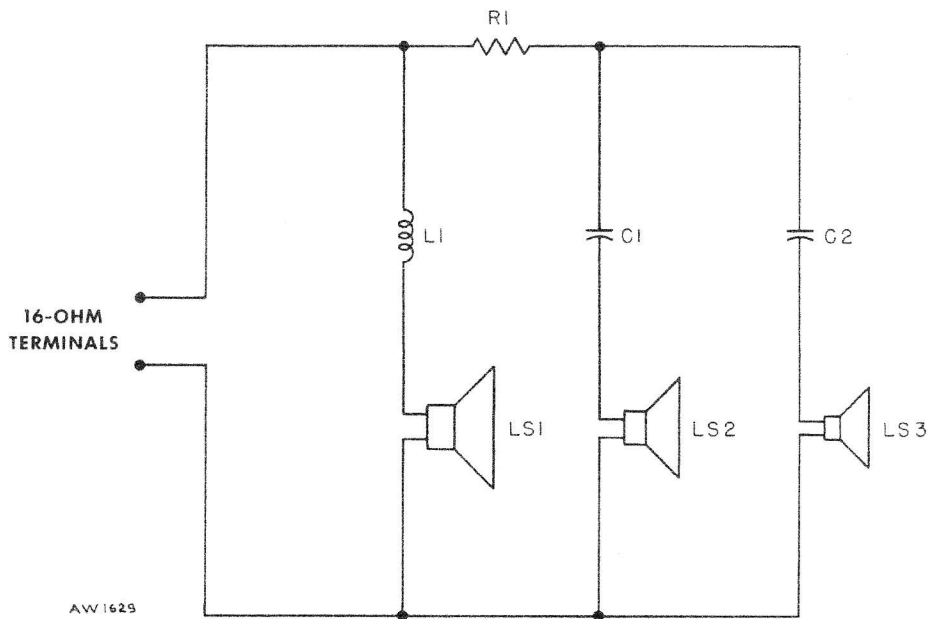

## PARTS LIST • SPEAKER SYSTEMS

Symbol	Description	Part No.
C1	Capacitor, electrolytic, 16uf, 50V	C765-107
C2	Capacitor, tubular, 2uf, 50V	C547-118
L1	Coil, 3 milhenries	L547-120
LS1	Loudspeaker, woofer, 16-ohm	LS765-106
LS2	Loudspeaker, midrange, 16-ohm	LS50123
LS3	Loudspeaker, tweeter, 16-ohm	LS547-124
R1	Resistor, wirewound, 6.8 ohms, 10% 5 W	R671-113

**NOTE:** Schematic diagram and parts list apply to both speaker systems, which contain the same components and are wired identically.

## PARTS LIST • RECORD CHANGER

Symbol	Description	Part No.
—	Record changer	RC547-121
—	Cartridge, magnetic, stereo	G50184



**FISHER RADIO CORPORATION • NEW YORK**