

Service Manual

THE FISHER®



President

MODEL 9011

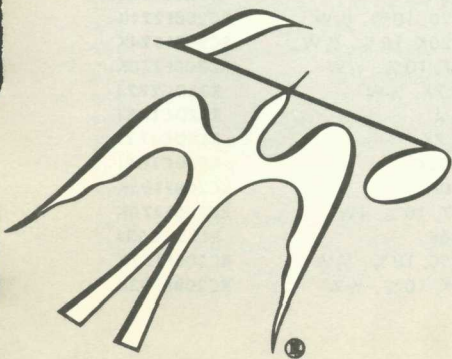

PARTS DESCRIPTION LIST • TUNER

CAPACITORS

10% tolerance for all fixed capacitors, unless otherwise noted or marked GMV (guaranteed minimum value). All capacitors not marked uf are pF (uuf).

Symbol	Description	Part No.
C1, 2	Ceramic, 100, N1500, 1000V	C50070-6
C3	Ceramic Trimmer	C662-123
C4	Variable	C857-115-1
C5	Ceramic, 10, ±.5, NPO, 500V	CC20CJ100D5
C6, 7, 8	Ceramic Feedthru, 1000, GMV	C592-187
C9	Molded, .01uf, 20%, 600V	C2747
C10	Ceramic Feedthru, 1000, GMV	C592-187
C11	Ceramic, 1000, GMV, 500V	C50089-2
C12	Ceramic Trimmer	C662-123
C13	Ceramic, 10, ±.5, NPO, 500V	CC20CJ100D5
C14	Ceramic, 3, NPO, 1000V	C50070-28
C15	Ceramic Trimmer	C662-123
C16, 17, 18	Ceramic Feedthru, 1000, GMV	C592-187
C19	Electrolytic, 25uf, 6V	C639-114
C20	Mylar, .1uf, 125V	C50435-7
C21	Electrolytic, 50uf, 70V	C50283-2
C22	Electrolytic, 40uf, 250V	C581-133
C23	Electrolytic, 2 Section: A — 1000uf, 35V B — 1000uf, 35V	C50180-29
C25	Electrolytic, 50uf, 70V	C50283-2
C26	Ceramic Feedthru, 1000, GMV	C592-187
C27	Ceramic, 5000, 20%, 500V	C50089-1
C28	Ceramic, 8, ±.5, NPO, 500V	CC20CJ080D5
C29	Ceramic Trimmer	C662-123
C30	Composition, 47K, 10%, 1/2 W	RC20BF473K
C32	Ceramic, 100, N1500, 1000V	C50070-6
C33	Ceramic, 6, ±.5, N470, 500V	CC20TJ060D5
C34	Ceramic, 100, N1500, 1000V	C50070-6
C35	Ceramic, .05uf, +80 —20%, 100V	C50073-2
C36	Mylar, .1uf, 250V	C50197-54
C37	Capacitor, Electrolytic, Non-polarized, 14uf, 15%, 50V	C882-252
C38	Electrolytic, 50uf, 70V	C50283-2
C39	Ceramic, 24, 5%, N150, 1000V	C50070-8
C40	Ceramic, 82, 5%, N1500, 1000V	C50070-33
C41	Ceramic Feedthru, 1000, GMV	C592-187
C42	Ceramic, 820, 1000V	C50072-7
C43, 44	Ceramic Feedthru, 1000, GMV	C592-187
C45	Ceramic, .02uf, +80 —20%, 500V	C50089-4
C46	Ceramic, 5000, 20%, 500V	C50089-1
C47, 48	Electrolytic, 1uf, 50V	C746-144
C49, 50	Ceramic, .05uf, +80 —20%, 100V	C50073-2
C51, 52, 53, 54, 55, 56,	Ceramic, 5000, +80 —20%, 500V	C50089-6
C57	Ceramic, .02uf, GMV, 1000V	C50071-6
C58	Ceramic, 2700, 1000V	C50072-17
C59	Ceramic, 5000, +80 —20%, 500V	C50089-6
C60	Ceramic, 5000, 20%, 500V	C50089-1
C61	Ceramic, 1, 20%, P-100, 1000V	C50070-1
C62, 63	Mylar, .1uf, 125V	C50435-7
C64	Ceramic, .05uf, +80 —20%, 100V	C50073-2
C65	Electrolytic, 4 Section: A — 40uf, 300V B — 40uf, 300V C — 40uf, 250V D — 40uf, 250V	C670-125B
C71	Ceramic, 5000, +80 —20%, 500V	C50089-6
C72	Ceramic, 2700, 1000V	C50072-17
C73	Ceramic, 24, 5%, N150, 1000V	C50070-8
C74	Ceramic, .02uf, GMV, 1000V	C50071-6

C75	Ceramic, 5000, +80 —20%, 500V	C50089-6
C76	Ceramic, 100, N1500, 1000V	C50070-6
C77	Ceramic, 5000, +80 —20%, 500V	C50089-6
C78	Ceramic, 5000, 20%, 500V	C50089-1
C79	Ceramic, 56, N1500, 1000V	C50070-22
C80	Ceramic, 39, N1500, 1000V	C50070-17
C81	Ceramic, 5000, 20%, 500V	C50089-1
C82	Ceramic, 390, 1000V	C50072-6
C83	Mylar, .1uf, 125V	C50435-7
C84	Ceramic, 56, N1500, 1000V	C50070-22
C85	Ceramic, 5000, 20%, 500V	C50089-1
C86	Ceramic, 390, 1000V	C50072-6
C87	Ceramic, 39, N1500, 1000V	C50070-17
C88	Mylar, .1uf, 125V	C50035-7
C89	Ceramic, 12, NPO, 1000V	C50070-2
C90	Electrolytic, 4uf, 50V	C50283-5
C91	Ceramic, 5000, +80 —20%, 500V	C50089-6
C92	Ceramic, 2700, 1000V	C50072-17
C93	Ceramic, .02uf, GMV, 1000V	C50071-6
C94	Ceramic, 5000, +80 —20%, 500V	C50089-6
C95	Ceramic, 39, N1500, 1000V	C50070-17
C96	Ceramic, 2700, 1000V	C50072-17
C97	Ceramic, .01uf, +80 —20%, 500V	C50089-7
C98	Electrolytic, 4uf, 50V	C50283-5
C100	Ceramic, 5000, +80 —20%, 500V	C50089-6
C101, 102, 103	Ceramic, 330, 1000V	C50072-1
C104, 105	Electrolytic, 8uf, 50V	C629-138
C106	Ceramic, .02uf, GMV, 1000V	C50071-6
C107	Mylar, .1uf, 125V	C50435-7
C108	Polystyrene, 2500, 5%, 125V	CP50394-9
C109	Mylar, .1uf, 125V	C50435-7
C110	Electrolytic, 2uf, 70V	C721-142
C111	Electrolytic, .5uf, 350V	C50283-7
C112	Mylar, .1uf, 125V	C50435-7
C113	Ceramic, 5000, +80 —20%, 500V	C50089-6
C114	Ceramic, 560, 1000V	C50072-14
C115	Ceramic, 5000, +80 —20%, 500V	C50089-6

RESISTORS & POTENTIOMETERS

In ohms, 5% tolerance, 1/8 watt unless otherwise noted. K=Kilohms, M=Megohms.

Symbol	Description	Part No.
R1	Composition, 100K, 10%, 1/2 W	RC20BF104K
R2	Dep. Carbon, 2.7K	R12DC272J
R3, 4	Dep. Carbon, 270	R12DC271J
R5	Composition, 120, 10%, 1/2 W	RC20BF121K
R6	Composition, 100K, 10%, 1/2 W	RC20BF104K
R7	Dep. Carbon, 820K	R12DC824J
R8	Dep. Carbon, 1M	R12DC105J
R9, 10	Dep. Carbon, 330K, 1/3 W	R33DC334J
R11	Dep. Carbon, 2.7K	R12DC272J
R12	Dep. Carbon, 470K	R12DC474J
R13	Dep. Carbon, 470	R12DC471J
R14	Composition, 4.7K, 10%, 2W	RC40BF472K
R15	Composition, 10, 10%, 2W	RC40BF100K
R16	Dep. Carbon, 10K	R12DC103J
R17, 18	Composition, 220, 10%, 1/2 W	RC20BF221K
R19	Composition, 820K, 10%, 1/2 W	RC20BF824K
R20	Composition, 27, 10%, 1/2 W	RC20BF270K
R21	Dep. Carbon, 2.7K, 1/3 W	R33DC272J
R22	Dep. Carbon, 1M	R12DC105J
R23	Dep. Carbon, 4.7K	R12DC472J
R24	Dep. Carbon, 100K	R12DC104J
R25	Composition, 10K, 10%, 1/2 W	RC20BF103K
R26	Composition, 47, 10%, 1W	RC30BF470K
R27	Dep. Carbon, 56K	R12DC563J
R28	Composition, 150, 10%, 1/2 W	RC20BF151K
R29	Composition, 1K, 10%, 1/2 W	RC20BF102K

PARTS DESCRIPTION LIST • TUNER

R30 Composition, 22K, 10%, 1/2 W
R31 Composition, 330K, 1/2 W
R32 Composition, 10K, 10%, 2W
R33 Dep. Carbon, 100K
R34, 35 Dep. Carbon, 1K, 1/3 W
R36 Dep. Carbon, 150K
R37 Composition, 39K, 10%, 1/2 W
R38, 39 Composition, 1K, 10%, 1/2 W
R40 Dep. Carbon, 220K
R41, 42 Glass, 270, 10%, 3W
R43 Composition, 3.3K, 10%, 1W
R44 Dep. Carbon, 39K
R45 Composition, 100K, 10%, 1/2 W
R46 Composition, 150, 10%, 1/2 W
R47 Composition, 1K, 10%, 1/2 W
R48 Dep. Carbon, 1M
R49 Dep. Carbon, 10K
R50 Dep. Carbon, 82K
R51 Dep. Carbon, 1.8M, 1/3 W
R52 Dep. Carbon, 4.7K
R53, 54 Dep. Carbon, 100K
R55 Composition, 1K, 10%, 1/2 W
R56 Dep. Carbon, 22K
R57 Composition, 68K, 10%, 1/2 W
R58, 59 Composition, 1K, 10%, 1/2 W
R60 Dep. Carbon, 100K, 1/3 W
R61 Dep. Carbon, 150K, 1/3 W
R62 Dep. Carbon, 680, 1/3 W
R63 Dep. Carbon, 100K, 1/3 W
R64 Dep. Carbon, 150K, 1/3 W
R65 Dep. Carbon, 680, 1/3 W
R66 Dep. Carbon, 22K
R67 Dep. Carbon, 47K
R68 Potentiometer, 50K, Tune-O-Matic Sensitivity
R69 Dep. Carbon, 22K
R70 Dep. Carbon, 4.7K
R71 Composition, 22M, 10%, 1/2 W
R72 Dep. Carbon, 100K, 1/3 W
R73 Composition, 22M, 10%, 1/2 W
R74 Dep. Carbon, 100K, 1/3 W
R75 Composition, 56K, 10%, 1/2 W
R76 Dep. Carbon, 15K
R77, 78 Composition, 1K, 10%, 1/2 W
R79 Dep. Carbon, 100K
R80 Composition, 68, 10%, 1/2 W
R81 Dep. Carbon, 150K, 1/3 W
R82 Dep. Carbon, 470K
R83 Potentiometer, 500K, Left Output Level
R84 Dep. Carbon, 1.8M, 1/3 W
R85 Dep. Carbon, 1M
R86 Dep. Carbon, 470K
R87 Potentiometer, 500K, Right Output Level
R88 Dep. Carbon, 1.8M, 1/3 W
R89 Dep. Carbon, 1M
R90 Dep. Carbon, 100K
R91 Composition, 6.8M, 10%, 1/2 W
R92 Composition, 2.7M, 10%, 1/2 W
R93 Dep. Carbon, 56K
R94 Dep. Carbon, 100K, 1/3 W
R95 Composition, 18K, 10%, 1W
R96 Composition, 47K, 10%, 1/2 W
R97 Composition, 270, 1/2 W
R98 Composition, 1K, 10%, 1/2 W
R99 Dep. Carbon, 47K
R100 Dep. Carbon, 470K
R101 Dep. Carbon, 150K
R102 Composition, 15, 10%, 1/2 W
R103 Dep. Carbon, 470K

RC20BF223K
RC20BF334J
RC40BF103K
R12DC104J
R33DC102J
R12DC154J
RC20BF393K
RC20BF102K
R12DC224J
RPG3W271K
RC30BF332K
R12DC393J
RC20BF104K
RC20BF151K
RC20BF102K
R12DC105J
R12DC103J
R12DC823J
R33DC185J
R12DC472J
R12DC104J
RC20BF102K
R12DC223J
RC20BF683K
RC20BF102K
R33DC104J
R33DC154J
R33DC681J
R33DC104J
R33DC154J
R33DC681J
R12DC223J
R12DC473J

R50103-3
R12DC223J
R12DC472J
RC20BF226K
R33DC104J
RC20BF226K
R33DC104J
RC20BF563K
R12DC153J
RC20BF102K
R12DC104J
RC20BF680K
R33DC154J
R12DC474J
R50103-6
R33DC185J
R12DC105J
R12DC474J
R50103-6
R33DC185J
R12DC105J
R12DC104J
RC20BF685K
RC20BF275K
R12DC563J
R33DC104J
RC30BF183K
RC20BF473K
RC20BF271J
RC20BF102K
R12DC473J
R12DC474J
R12DC154J
RC20BF150K
R12DC474J

R104 Dep. Carbon, 56K
R105 Dep. Carbon, 100K
R106 Composition, 1.5K, 1/2 W
R107 Composition, 1K, 1/2 W
R108, 109 Composition, 4.7K, 1/2 W
R110, 111,
112, 113 Dep. Carbon, 820K
R114 Dep. Carbon, 1K, 1/2 W
R115 Dep. Carbon, 100
R116, 117 Dep. Carbon, 39K
R117 Dep. Carbon, 1.8M, 1/3W
R118 Potentiometer, Bias Adjust

R12DC563J
R12DC104J
RC20BF152J
RC20BF102J
RC20BF472K

R12DC824J
R33DC102J
R12DC101J
R12DC393J
R33DC185J
R998-136

COILS, CHOKES AND TRANSFORMERS

Symbol	Description	Part No.
L1	FM Antenna Coil	L726-124
L2	Choke, 1 Microhenry	L50066-2
L3	Choke, .68 Microhenry	L50066-1
L4	Choke, 1.2 Microhenries	L50066-3
L5	Choke, RF	L629-180
L6	Coil, FM RF	L857-122
L7	FM Oscillator Coil Assembly	AS857-125
L8	Choke, .68 Microhenry	L50066-1
L9, 10,		
11, 12	Choke, 1.2 Microhenries	L50066-3
L13	Choke, 3.3 Microhenries	L50066-8
L14	Coil, FM Mixer	L857-123
T1	Transformer, Power	T998-115
Z1	FM IF Transformer	ZZ662-117
Z2	FM IF Transformer	ZZ2987
Z3	FM IF Transformer	ZZ50210-2
Z4	FM Limiter Coil	ZZ50210-6
Z5	FM Limiter Coil Assembly	L935-122
Z6	FM Ratio Detector Assembly	ZZ50210-9
Z7	FM IF Transformer	ZZ50210-19

MISCELLANEOUS

Symbol	Description	Part No.
CR1	Diode, Varicap	V726-130
CR2, 3	Diode, Silicon, Type 1112	V-1112
CR4, 12	Diode, Silicon, 200 PIV, 750MA	SR851-122
CR5	Diode, Silicon, Type 1112	V-1112
CR6	Diode, Type 1N541	V-IN541
CR7, 8, 9,		
10, 11	Diode, Silicon, Type 1112	V-1112
F1	Fuse, 1.5 Amp., Slo-Blo	F684-143
I1, 2	Lamp, Dial	I50441-3
I3	Dial Pointer Assembly, incl. 2.5V bulb	AS50451-1
I4, 5	Lamp #47, Sta. Indicator, Stereo Beacon	I50009-1
K1, 2	Part of Motor & Gear Assembly	P-882
K3	Relay	K50446
K4	Relay	K50314
M1	Motor, part of Motor & Gear Assembly	P-882
S1	Switch, Antenna	S998-120
S2	Switch, Right Return	S882-244-1
S3	Switch, Left Return	S882-244-2
S4	Switch, AFC	S998-122
S5	Switch, Muting	S998-121
S6	Switch, Selector	S998-123
S7	Switch, Stereo Filter	S998-124
S8	Switch, Pushbutton	S998-114
SR1	Selenium Rectifier Bridge	SR50279-1
—	Dipole Assembly	AS50227-1
—	Dress Panel	AS998-108
—	Knob, Tuning	E50325-2
—	Knob	E50325-1
—	Knob, Pushbutton	E851-116
—	Dial Glass	N998-107
—	Fuse Holder	X563-151

ALIGNMENT INSTRUCTIONS • TUNER

Read These Instructions With Extreme Care Before Attempting Alignment.

CHASSIS: Disconnect the external antenna. When using an oscilloscope for alignment, set the AUDIO LEVEL control for no overload, as shown by the proper waveform shape. Set remaining controls as follows: Selector, MONO; Muting, OFF; AFC, OFF; Antenna, NORMAL; Stereo Filter, OFF; TUNE-O-MATIC Sensitivity, 0.

SIGNAL GENERATOR: The signal generator equipment must be able to supply RF ± 22.5 KC deviation at 400 cps.

INDICATOR: DC VTVM, and scope for alignment.

ALIGNMENT: Allow the chassis and test instruments to warm up for at least 15 minutes. Adjust the line voltage for 117 volts AC, 50-60 cps. Use fully insulated tools: a small screwdriver for all trimming capacitors; a K-tran tool for Z1, Z2, Z3; a hex tool for Z4, Z5, Z6, Z7, L1, L6, L14 and L7.

NOTES: 1—For accurate alignment, signal generator output voltage must be adjusted to produce meter readings within the range specified in the INDICATION column for each step.

2—Signal generator frequency should be held constant for IF, limiter, center of channel detector and ratio detector alignment (Z1 through Z7).

FM ALIGNMENT (tuner only)

STEPS	CHASSIS	SIGNAL GENERATOR			INDICATOR	ALIGNMENT	
	TUNING	COUPLING	FREQ.	MOD.	TYPE CONNECTION	ADJUST	INDICATION
1	Point of no signal and no interference	FM generator connected to pin 1 of V6	10.7 MC	None	Connect DC VTVM to test point 3	Z4, Z5 top, Z6 bottom and top for max. indication	Between +5 and +9 volts
2	Point of no signal and no interference	FM generator connected to pin 1 of V6	10.7 MC	None	Connect DC VTVM to test point 4	Z6 top for min. indication	Zero reading on zero center scale
3	Point of no signal and no interference	FM generator connected to pin 1 of V5	10.7 MC	None	Connect DC VTVM to test point 2	Z3 top and bottom for max. indication	Between -0.5 and -1.0 volt
4	Point of no signal and no interference	FM generator connected to test point 1 through wire "gimmick" (less than 0.5 uuf)	10.7 MC	None	Connect DC VTVM to test point 2	Z1 and Z2 top and bottom for max. indication	Between -0.5 and -1.0 volt
5	Point of no signal and no interference	FM generator connected to test point 1 through wire "gimmick" (less than 0.5 uuf)	10.7 MC	None	Connect DC VTVM to test point 5	Z7 top and bottom	Between +10 and +15 volts
6	90 MC	FM generator connected to 300 ohm terminals through 120 ohm carbon resistors	90 MC	30% FM (22.5 KC Dev.) at 400 cps.	DC VTVM to test point 2 and scope to RIGHT or LEFT OUTPUT jack	L7, L14, L6 and L1 for sine waveform and max. neg. voltage	Less than -3 volts
7	106 MC	FM generator connected to 300 ohm terminals through 120 ohm carbon resistors	106 MC	30% FM (22.5 KC Dev.) at 400 cps.	DC VTVM to test point 2 and scope to RIGHT or LEFT OUTPUT jack	C15, C29, C12 and C3 for sine waveform and max. neg. voltage	Less than -3 volts
8	Repeat steps 6 and 7 for proper dial calibration and maximum output.						
9	98 MC	FM generator connected to antenna term. through 120-ohm carbon resistors	98 MC	30% FM (22.5 KC Dev.) at 400 cps, 8uV output	Connect DC VTVM to test point 5	TUNE-O-MATIC control to position where Station Indicator starts to light	More than +8 volts

ALIGNMENT INSTRUCTIONS • MULTIPLEX SECTION

STEPS	GENERATOR			INDICATOR	ALIGNMENT		
	CONNECTION	AUDIO FREQUENCY	RF MODULATION	TYPE & CONNECTION	ADJUST	INDICATION	NOTES
1	Audio oscillator connected to lug 1	80 KC—1 volt	None	AC VTVM to junction of C210 and R228	L100 (Use hex alignment tool)	Minimum voltage	
2	Multiplex generator audio output to lug 1 (See Note 1)	19 KC (± 5 cps) pilot tone, 100 mv	None	DC VTVM to T.S.P. 101	Z100 top and bottom (Use hex alignment tool)	Maximum voltage	1
3	Same as Step 2	19 KC pilot tone, 50 mv	None	Scope horiz. input to 19 KC output of gen.; vert. input to junction of C216 and R209. External sweep	Z101 (Use K-tran alignment tool)	Stable 2:1 Lissajous pattern. Disregard phase of pattern	1
4	Same as Step 2	19 KC	None	Same as Step 3	Vary generator 19 KC output from 50 to 200 mv	Lissajous pattern should remain stationary over the entire 150 mv range	1, 2
5	Same as Step 2	1000 cps on left (A) channel only, 1 volt rms (2.8 P-P)	None	AC VTVM and scope vert. input to channel A output lug. Internal sweep. DC VTVM to T.S.P. 101	Z100 top (Use hex tool)	Maximum indication on AC VTVM. Clean 1000 cps waveform on scope	1, 3
6	Same as Step 2	1000 cps on right (B) channel only, 1 volt rms (2.8 P-P)	None	Same as Step 5	MPX separation R215	Minimum reading on AC VTVM should be at least 33 db below reading obtained in Step 5	1
7	Same as Step 2	Same as Step 6	None	Move scope input and AC VTVM to channel B output lug	-----	Note and record voltage reading on AC VTVM	1
8	Same as Step 2	1000 cps on left (A) channel only, 1 volt rms (2.8 P-P)	None	Same as Step 7	-----	AC VTVM reading should be at least 33 db below reading observed in Step 7	1
9	Same as Step 2	8000 cps on right (B) channel only, 1 volt rms (2.8 P-P)	None	Same as Step 7	-----	AC VTVM reading should be the same as observed in Step 7	1
10	Same as Step 2	8000 cps on left (A) channel only, 1 volt rms (2.8 P-P)	None	Same as Step 7	-----	AC VTVM reading should be at least 18 db below reading observed in Step 9	1
11	Repeat Steps 9 and 10 with scope and AC VTVM connected to channel A output lug, but start with 8000 cps applied to left channel for first reading, then switch to right channel for second reading.						
12	Multiplex generator RF output to 300-ohm antenna terminals	1000 cps on left (A) channel only	100% (75 KC Dev.) No pre-emphasis	Move scope input and AC VTVM to channel A output lug	-----	Note and record voltage reading on AC VTVM	4
13	Same as Step 12	1000 cps on right (B) channel only	Same as Step 12	Same as Step 12	R215	Minimum reading on AC VTVM should be at least 33 db below reading observed in Step 12	4
14	Same as Step 12	8000 cps on left (A) channel only	Same as Step 12	Same as Step 12	-----	AC VTVM reading should be 10 db below reading observed in Step 12	4
15	Same as Step 12	8000 cps on right (B) channel only	Same as Step 12	Same as Step 12	-----	AC VTVM reading should be 28 db below reading observed in Step 12	4

NOTE: The above procedure is based on the use of the FISHER Model 300 Multiplex Generator.

1 — In steps 2 through 11, the audio output of the Multiplex Generator should be connected to lug 1 of the multiplex sub-chassis through a 12,000 ohm, ½-watt, carbon resistor, and a 180 uuf capacitor should be connected between lug 1 and ground. The wiring from the MPX TEST jack on the main chassis to lug 1 must be disconnected during Steps 2 through 11.

2 — The vertical amplitude of the Lissajous pattern will increase slightly

as the generator output is increased. This is a normal occurrence.

3 — If DC VTVM reading falls below -9 volts when maximum reading is obtained on the AC VTVM, readjust bottom of Z100, then repeat Step 5. Repeat this procedure until maximum AC VTVM reading is obtained with DC VTVM reading greater than -9 volts.

4 — Tune the FISHER to the RF output frequency of the Multiplex Generator.

PARTS DESCRIPTION LIST • PREAMPLIFIER

CAPACITORS

10% tolerance for all fixed capacitors, unless otherwise noted or marked GMV (guaranteed minimum value).

Symbol	Description	Part No.
C1, 2	Ceramic, 100uf, N1500, 100V	C50070-6
C3, 4	Mylar, .022uf, 250V	C50197-49
C13, 14	Mylar, .047uf, 250V	C50197-52
C30, 31	Ceramic, 100uf, N1500, 1000V	C50070-6
C32	Electrolytic, 2 section A — 1000uf, 35V B — 1000uf, 35V	C50180-29
C33	Electrolytic, 4 section A — 40uf, 450V B — 10uf, 450V C — 10uf, 450V D — 40uf, 450V	C50180-10
C34	Electrolytic, 4 section A — 30uf, 350V B — 10uf, 250V C — 30uf, 350V D — 10uf, 300V	C50180-30
C35, 36	Ceramic, .005uf, 20%, 500V	C50089-1
C37, 38	Ceramic, .0039uf, 1000V	C50072-34
C41, 42	Mylar, .1uf, 250V	C50197-54
C43, 44, 45, 46	Electrolytic, 50uf, 3V	C50283-1
C47, 48	Mylar, .1uf, 250V	C50197-54
C49, 50, 51, 52	Ceramic, 24uf, 5%, N150, 1000V	C50070-8
C53, 54	Mylar, .033uf, 250V	C50197-51
C55, 56	Ceramic, 2700uf, 1000V	C50072-17
C57, 58	Electrolytic, 50uf, 3V	C50283-1
C59, 60	Ceramic, 300uf, 1000V	C50072-39
C63, 64	Ceramic, 1000uf, 1000V	C50072-3
C65, 66	Ceramic, 220uf, 1000V	C50072-20
C67, 68	Mylar, .68uf, 250V	C50197-57
C69, 70	Ceramic, 220uf, 1000V	C50072-20
C71, 72	Mylar, .047uf, 250V	C50197-52
C73, 74	Mylar, .68uf, 250V	C50197-57
C75, 76, 77, 78	Electrolytic, 50uf, 3V	C50283-1
C79, 80	Mylar, .68uf, 250V	C50197-57

RESISTORS AND POTENTIOMETERS

In ohms, 10% tolerance, 1/2 watt, unless otherwise noted. K=Kilohm, M=Megohm.

Symbol	Description	Part No.
R3, 4, 5, 6	Dep. Carbon, 100K, 5%, 1/3 W	R33DC104J
R7, 8, 9, 10	Dep. Carbon, 120K, 5%, 1/3 W	R33DC124J
R11	Potentiometer, Dual, 250K, aux. 2 level	R50160-71
R12, 13	Dep. Carbon, 100K, 5%, 1/3 W	R33DC104J
R14, 15	Dep. Carbon, 10K, 5%, 1/3 W	R33DC103J
R16, 17	Glass, 2.7K, 5%, 1W	R30G272J
R18, 19	Glass, 330K, 5%, 1W	R30G334J
R20, 21	Dep. Carbon, 4.7M, 5%, 1/3 W	R33DC475J
R26, 27	Dep. Carbon, 220K, 5%, 1/3 W	R33DC224J
R28, 29	Composition, 560K	RC20BF564K
R30	Dep. Carbon, 100K, 5%, 1/3 W	R33DC104J
R32, 33	Potentiometer, Dual, 250K, Mag. 1 & Mag. 2 level	R50160-71
R39	Dep. Carbon, 100K, 5%, 1/3 W	R33DC104J
R50, 51	Dep. Carbon, 120K, 5%, 1/3 W	R33DC124J
R52	Glass, 330, 3W	RPG3W331K
R53	Wirewound, 10K, 7W	R851-128
R54	Glass, 1K, 3W	RPG3W102K
R55	Composition, 47K	RC20BF473K
R56	Glass, 1K, 3W	RPG3W102K
R57, 58	Composition, 1.5M	RC30BF155K
R59	Glass, 5.6K, 3W	RPG3W562K
R60	Glass, 1K, 3W	RPG3W102K
R61, 62	Dep. Carbon, 220K, 5%, 1/3 W	R33DC224J

R63	Glass, 4.7K, 3W
R64, 65	Composition, 300K, 5%
R66, 67	Dep. Carbon, 100K, 5%, 1/3 W
R68	Composition, 1.5K
R69, 70	Composition, 1.5K
R71, 72	Composition, 330K
R73	Dep. Carbon, 4.7M, 5%, 1/3 W
R75, 76	Dep. Carbon, 220K, 5%, 1/3 W
R77, 78	Dep. Carbon, 2.7K, 5%, 1/3 W
R79, 80	Dep. Carbon, 100K, 5%, 1/3 W
R81, 82	Dep. Carbon, 470K, 5%, 1/3 W
R83	Potentiometer, dual, 250K, balance
R84, 85, 86, 87	Dep. Carbon, 470K, 5%, 1/3 W
R88	Composition, 33
R89, 90	Composition, 2.7M, 5%
R91, 92	Composition, 2.2M, 5%
R93, 94	Dep. Carbon, 470K, 5%, 1/3 W
R95	Potentiometer, dual, 1M, dimension
R96	Dep. Carbon, 470K, 5%, 1/3 W
R97, 98	Dep. Carbon, 120K, 5%, 1/3 W
R99, 100	Composition, 1.8K
R101, 102, 103, 104, 105, 106	Dep. Carbon, 47K, 5%, 1/3 W
R107, 108	Composition, 68K, 10%, 1W
R109, 110	Dep. Carbon, 470K, 5%, 1/3 W
R111, 112	Dep. Carbon, 10K, 5%, 1/3 W
R113	Dep. Carbon, 220K, 5%, 1/3 W
R114, 115	Dep. Carbon, 220K, 5%, 1/3 W
R116, 117	Dep. Carbon, 2.7K, 5%, 1/3 W
R118, 119	Dep. Carbon, 22K, 5%, 1/3 W
R120	Potentiometer, dual, 100K, volume
R121	Dep. Carbon, 470K, 5%, 1/3 W
R122	Potentiometer, dual, 1M, bass
R123	Potentiometer, dual, 500K, treble
R124	Potentiometer, 500K, center volume
R125, 126	Dep. Carbon, 270K, 5%, 1/3 W
R127, 128	Composition, 1.5K
R129, 130	Composition, 180K
R131, 132	Composition, 68K, 1W
R133, 134	Dep. Carbon, 3.3M, 5%, 1/3 W

RPG3W472K
RC20BF304J
R33DC104J
RC20BF153K
RC20BF152K
RC20BF334K
R33DC475J
R33DC224J
R33DC272J
R33DC104J
R33DC474J
R50160-65
R33DC474J
RC20BF330K
RC20BF275J
RC20BF225J
R33DC474J
R50160-70
R33DC474J
R33DC124J
RC20BF182K

R33DC473K
R30BF683K
R33DC474J
R33DC103J
R33DC224J
R33DC224J
R33DC272J
R33DC223J
R50160-69
R33DC474J
R50160-66
R50160-67
R50160-68
R33DC274J
RC20BF152K
RC20BF184K
R30BF683K
R33DC335J

MISCELLANEOUS

Symbol	Description	Part No.
F1	Fuse, .5 amp., slo-blo	F795-136
I1, 2, 3, 4, 5	Lamp, #47	I50009-1
PC1, 2	Printed Circuit, 3 3/4", tape EQ.	PC50187-7
PC3, 4	Printed Circuit, COL, EQ	PC50187-6
PC5, 6	Printed Circuit, 78, EQ.	PC50187-8
PC7, 8	Printed Circuit, R1AA, 7 1/2", EQ.	PC50187-3
PC9, 10	Printed Circuit, tone control	PC657-140
P1	Plug, dummy	P50181
S1	Switch, low level	S851-126
S2	Switch, mono-stereo	S851-127
S3	Switch, push button	S851-119
S4	Switch, center ch., power	Part of R124
S5, 6, 7, 8, 9	Switch, slide	S50200-5
S10	Switch, power	Part of R120
SR1, 2	Diode, silicon, SD91	SR851-121
T1	Transformer, power	T851-115
—	Dress panel	AS851-106
—	Shielded cable	AS50004-1
—	Knob, push button	E851-116
—	Knob, dual, front	E50323
—	Knob, dual, rear	E50221
—	Knob	E50325-1
—	Jewel, red	I50162-1
—	Jewel, yellow	I50162-2
—	Jewel, green	I50162-4

PARTS DESCRIPTION LIST • MULTIPLEX SECTION

CAPACITORS

10% tolerance for all fixed capacitors, unless otherwise noted or marked GMV (guaranteed minimum value). All capacitors not marked uf are pF (uuf).

Symbol	Description	Part No.
C200	Ceramic, .01uf, +80 —20%, 500V	C50089-7
C201	Ceramic, 680, 1000V	C50072-2
C203	Ceramic, 220, 1000V	C50183-3
C204	Mica, 470, 5%, 300V	C50332-4
C205	Ceramic, 82, N1500, 1000V	C50070-7
C206	Ceramic, .001uf, GMV, 500V	C50089-2
C207	Ceramic, .005uf, +80 —20%, 500V	C50089-6
C208, 209	Mica, 4700, 5%, 500V	C50332-5
C210	Electrolytic, 1uf, 350V	C50283-3
C211, 212	Ceramic, .001uf, GMV, 500V	C50089-2

C214	Mylar, .0047uf, 400V
C215	Mica, 3900, 5%, 500V
C216, 217	Ceramic, .001uf, GMV, 500V
C218	Ceramic, .02uf, 20% 500V
C219	Ceramic, 330, 1000V
C220	Ceramic, .02uf, 20%, 500V
C221, 222	Mylar, .047uf, 10%, 250V
C223, 224	Ceramic, .001uf, 1000V
C225, 226	Ceramic, 2200, 1000V

RESISTORS AND POTENTIOMETERS

In ohms, 10% tolerance, 1/2 watt, unless otherwise noted. K=Kilohm, M=Megohm.

Symbol	Description	Part No.
R200	Composition, 22M	RC20BF226K

C50197-25	R201	Composition, 4.7K, 5%
C50332-6	R202	Composition, 15K, 5%
C50089-2	R203	Composition, 10M
C50089-5	R204	Dep. Carbon, 1M, 5%, 1/3 W
C50072-1	R205	Dep. Carbon, 330K, 5%, 1/3 W
C50089-5	R206	Dep. Carbon, 1M, 5%, 1/3 W
C50197-52	R207	Dep. Carbon, 1.5M, 5%, 1/3 W
C50072-3	R208	Dep. Carbon, 22K, 5%, 1/3 W
C50072-5	R209, 210,	211, 212 Composition, 33K, 5%
	R213, 214	Dep. Carbon, 100K, 5%, 1/3 W
	R215	Potentiometer, 50K, MPX-separation
	R216	Composition, 10M
	R217, 218	Dep. Carbon, 18K, 5%, 1/3 W
	R219, 220	Dep. Carbon, 15K, 5%, 1/3 W

RC20BF472J	R221	Composition, 10M
RC20BF153J	R222, 223,	224, 225 Dep. Carbon, 22K, 5%, 1/3 W
RC20BF106K	R226, 227,	228, 229,
R33DC105J	230	Dep. Carbon, 1M, 5%, 1/3 W
R33DC334J		
R33DC105J		
R33DC155J		
R33DC223J		
RC20BF333J		
R33DC104J		
R50150-4		
RC20BF106K		
R33DC183J		
R33DC153J		

MISCELLANEOUS

Symbol	Description	Part No.
CR100, 101,	102, 103 Diode, Type 1112	V-1112
L100	Coil, Low Pass	L50210-30
L101	Coil, 5.25 M.H., 5%	L50334-1
L102, 103	Coil, 20 M.H., 5%	L50334-2
Z100	Transformer, 19Kc	ZZ50210-34
Z101	Coil, 38Kc	ZZ50210-33

SCHEMATIC DIAGRAM • MULTIPLEX SECTION

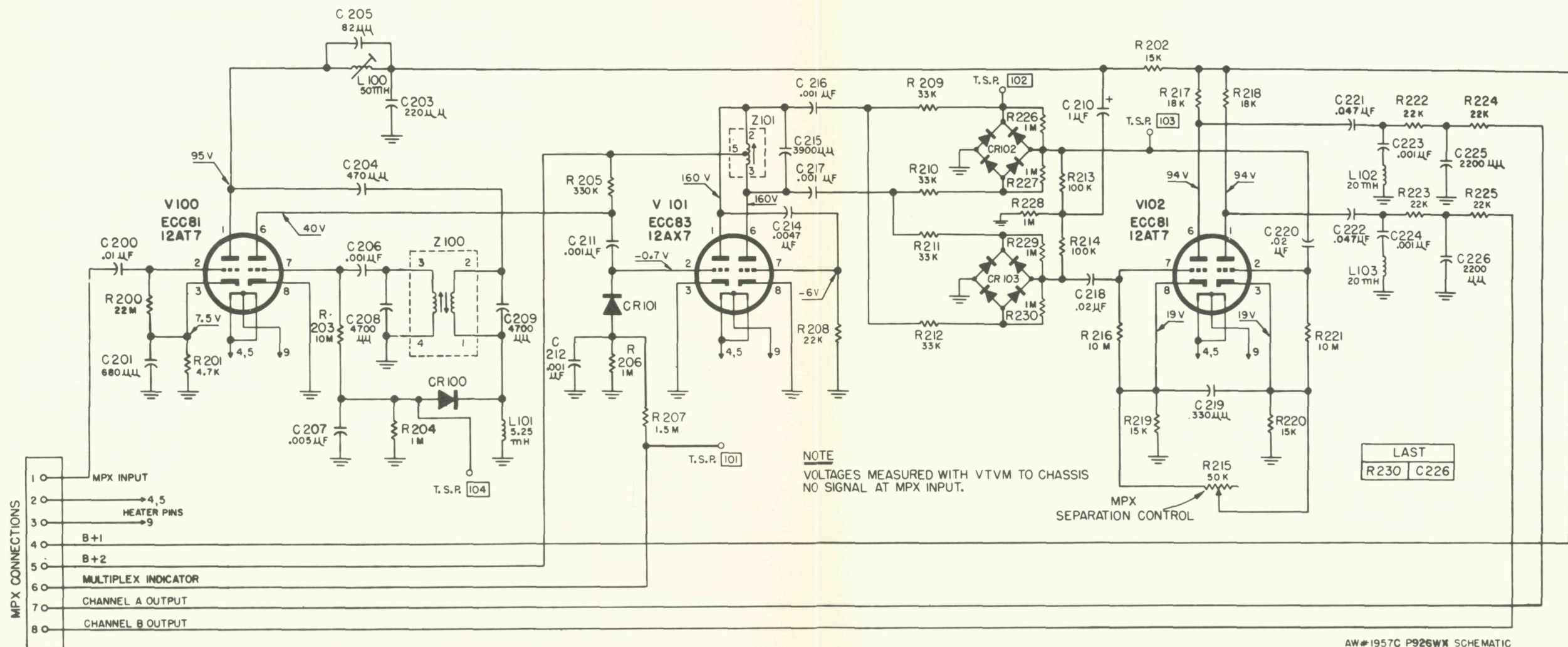

PARTS DESCRIPTION LIST • POWER AMPLIFIER

CAPACITORS

All capacitors not marked are pF (uuf).

Symbol	Description	Part No.
C1, 2	Ceramic, 39, 10%, 1000V	C50070-17
C3, 4	Electrolytic, .5uf, 35V	C50483-11
C5, 6	Electrolytic, 500uf, 10V	C50483-9
C7, 8	Ceramic, 300, 10%, 1000V	C50072-39
C9, 10	Ceramic, 330, 10%, 1000V	C50072-1
C11, 12	Electrolytic, 50uf, 10V	C50283-6
C13, 14	Electrolytic, 200uf, 35V	C50483-7
C15, 16, 17, 18	Electrolytic, 100uf, 25V	C50483-6
C19, 20	Ceramic, 330, 10%, 1000V	C50072-1
C21, 22	Electrolytic, 3000uf, 40V	C50180-60
C23, 24	Electrolytic, 200uf, 35V	C50483-7
C25	Electrolytic, 2 section: A—1500uf, 35V B—1500uf, 45V	C50180-62
C26	Molded, .01uf, 20%, 600V	C2747

RESISTORS AND POTENTIOMETERS

In ohms, 5% tolerance, 1/8 Watt unless otherwise noted. K=Kilohm, M=Megohm.

Symbol	Description	Part No.
P1, 2, 3, 4	Potentiometer, wirewound, 10, 20%, 2W	R50160-141-1
R1, 2	Dep. Carbon, 1M	R12DC105J
R3, 4	Dep. Carbon, 3.3K	R12DC332J
R5, 6	Dep. Carbon, 220K	R12DC224J
R7, 8	Dep. Carbon, 18K	R12DC183J
R9, 10	Dep. Carbon, 8.2K	R12DC822J
R11, 12	Dep. Carbon, 1K	R12DC102J
R13, 14	Dep. Carbon, 100	R12DC101J
R15, 16	Dep. Carbon, 3.9K	R12DC392J
R17, 18	Dep. Carbon, 5.6K	R12DC562J

R19, 20	Glass, 100, 10%, 3W	RPG3W101K
R21, 22	Dep. Carbon, 390	R12DC391J
R23, 24, 25, 26	Wirewound, 270, 2W	RW200W271J
R27, 28, 29, 30	Wirewound, 100, 2W	RW200W101J
R31, 32, 33, 34	Wirewound, 220, 2W	RW200W221J
R35, 36, 37, 38	Wirewound, 1, 3W	RL300W010J
R39, 40	Wirewound, Dual, 15 & 10, 10%, 10W	R50500-2
R41, 42	Composition, 1K, 10%, 1/2 W	RC20BF102K
R43	Wirewound, 15, 10%, 5W	R719-106
R44	Wirewound, 1, 3W	RL300W010J
R45	Composition, 820K, 10%, 1/2 W	RC20BF824K

MISCELLANEOUS

Symbol	Description	Part No.
CR1, 2	Silicon Rectifier	SR50411-1
F1, 2, 3, 4	Fuse, 2 Amp, Slo-Blo	F50512-1
F5	Fuse, 2.5 Amp, Slo-Blo	F1077-118
Q1, 2, 8, 9	Transistor	TR-2N2375
Q3, 4, 5, 6, 7, 10, 11, 12, 13, 14	Transistor	TR-35144*
SR1, 2, 3, 4	Silicon Rectifier	SR50517
T1, 2	Transformer, Driver	T1077-116
T3	Transformer, Power	T1077-115
—	Mica Insulator for Power Transistors	E50510
—	Headphone Jack	J1061-120
—	Switch, Speaker Selector	S1062-119

NOTE: *Transistor must be replaced with one from the same Beta group.

TUBE LAYOUT • POWER AMPLIFIER

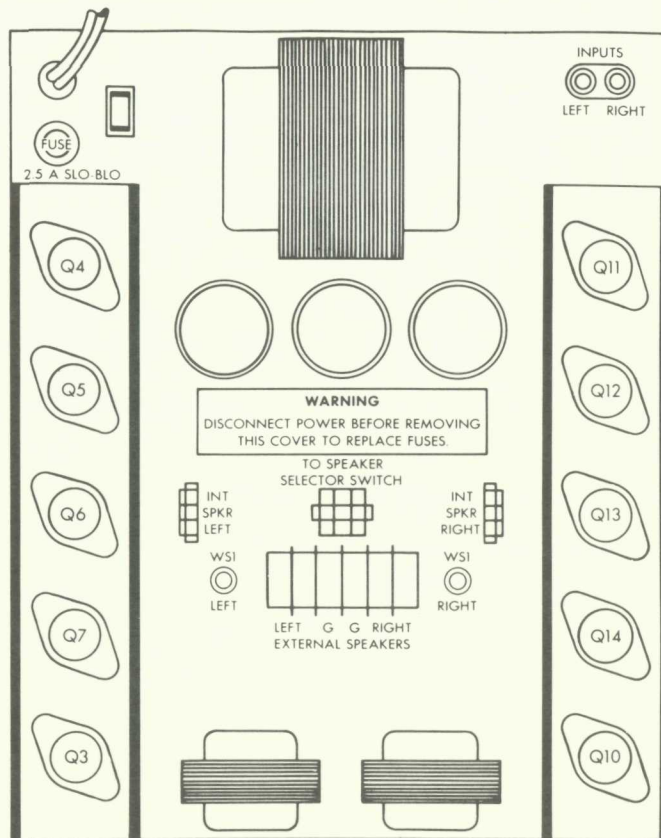

ADJUSTMENTS • TUNER MOTOR DRIVE

pointer and limit switch adjustment

1 — Turn the Tuning knob completely counterclockwise without forcing. The white line on the dial pointer should be at the zero index mark on the logging scale.

2 — If the dial pointer is not at the zero mark, reset the dial pointer by moving it along the dial string.

3 — Check for proper operation by turning the set on, disconnecting the antenna, turning the Sensitivity switch to LOC and the Muting switch to MAX. Press one of the pushbuttons. The dial pointer should traverse the entire band, and reverse direction when it reaches each end of the scale.

4 — If the dial pointer fails to reverse direction at one end of the scale, turn the set off and remove the brass front panel. The limit switch is located directly behind the dial panel. (See Figure 1.) The pointer should contact the arm of the switch, causing it to make a contact (with an audible click) which reverses the direction of the pointer travel. As the pointer starts back in the reverse direction, the switch lever should spring back, breaking the contact.

5 — If the limit switch fails to operate in this manner, loosen the screw (A) and reposition the switch by sliding it along the slots on the panel. After adjustment, check for proper operation by bringing the dial pointer to the end of the band (with the Tuning knob). As the pointer contacts the limit switch a click should be heard (with very light pressure on the Tuning knob), and another click should be heard as the dial pointer is moved toward the center of the band. Continue adjustment until this operation is observed, then repeat step 3.

6 — If correct operation is still not observed, see Mechanical Check-List section under TUNE-O-MATIC ADJUSTMENT.

electrical checklist

1 — Perform the normal alignment of the tuner, steps 1 through 9.

2 — With the test instruments connected and supplying voltages as in step 9 of the Alignment Instructions, reduce the output voltage of the signal generator to 0. The Station Indicator should go off.

3 — Increase the deviation of the FM signal generator to ± 75 KC. Make sure that the Muting Switch is OFF. Increase the generator output gradually until

the Station Indicator goes on. At this point, the generator output should be less than or equal to 20 μ V.

4 — Set the generator output to 0, the deviation to ± 22.5 KC, and the Muting Switch to NORMAL. Increase the generator output gradually until the Station Indicator goes ON. The generator output at this point should be 10-20 μ V.

5 — Repeat step 4 with the Muting Switch in the MAX position. The Station Indicator should go ON with the generator output between 200-2000 μ V.

6 — Set the generator output to 100 μ V. By using the Pushbuttons, approach the generator frequency (98 MC) from both directions. Observe the stopping point of the dial pointer in each case. The stopping points should be within one division of the logging scale. Follow the same procedure with several stations, after connecting the antenna. If proper operation is not observed, proceed with the MECHANICAL CHECK-LIST below.

mechanical checklist

1 — Turn the set OFF. Remove the center housing clip (see Figure 2) by pulling upward, and the two side brackets with two hex screws.

2 — The solenoid plungers (Figure 3) should both move inward easily under hand pressure. If they do not, remove the end clip (Figure 4) and switch lever (Figure 4). If the solenoid plunger now moves freely, the switch lever is not centered and should be rotated until it is centered on the plunger. Reposition the switch lever and end clip on the solenoid plunger.

3 — Press each solenoid plunger slowly and observe the operation of each stack switch (Figure 4). As the plunger is pressed inward, the contacts labeled 1 (in Figure 4) should make contact first, the contacts labeled 2 should make contact second, and the contacts labeled 3 should make contact third. If this is not the case, slight bending of the contact arms with a miniature set of long-nose pliers will restore the correct sequence.

4 — As shown in Figure 3 the take-off gear should be centered between the two sections of the clutch. If it is not, rotate the set screw (Figure 5) with an **allen wrench** until the gear is centered.

5 — If the two sets of gears do not mesh properly (if they either bind or slip) when engaged by pressing one of the solenoid plungers, the distance D (see Figure 3) must be adjusted by turning the brass hex post with a wrench. Rotate the hex post until the two gears turn together without slipping or binding.

ADJUSTMENTS • TUNER MOTOR DRIVE

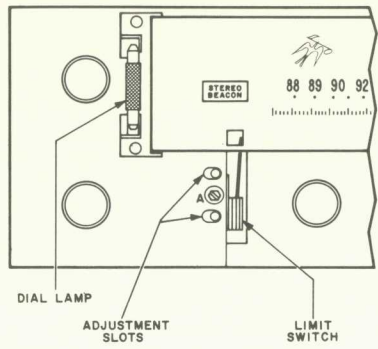
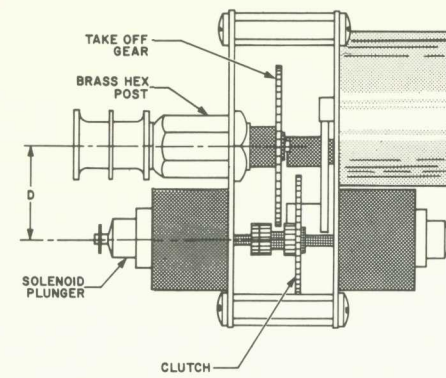

FIGURE 1 — Limit switch adjustment

FIGURE 3 — Motor drive assembly, top view



NOTE: The take-off gear should be centered between the two sections of the clutch, as shown.

FIGURE 4 — Solenoid stack switches, rear view

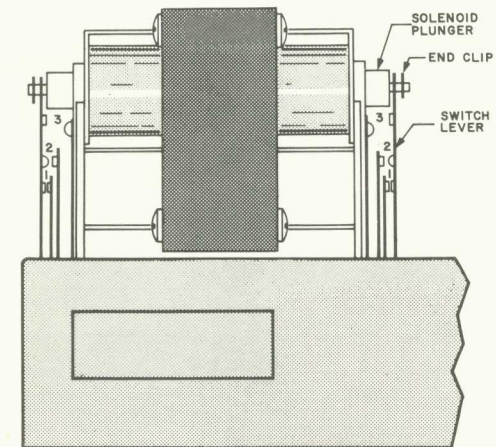

FIGURE 2 — Removing the center and side covers

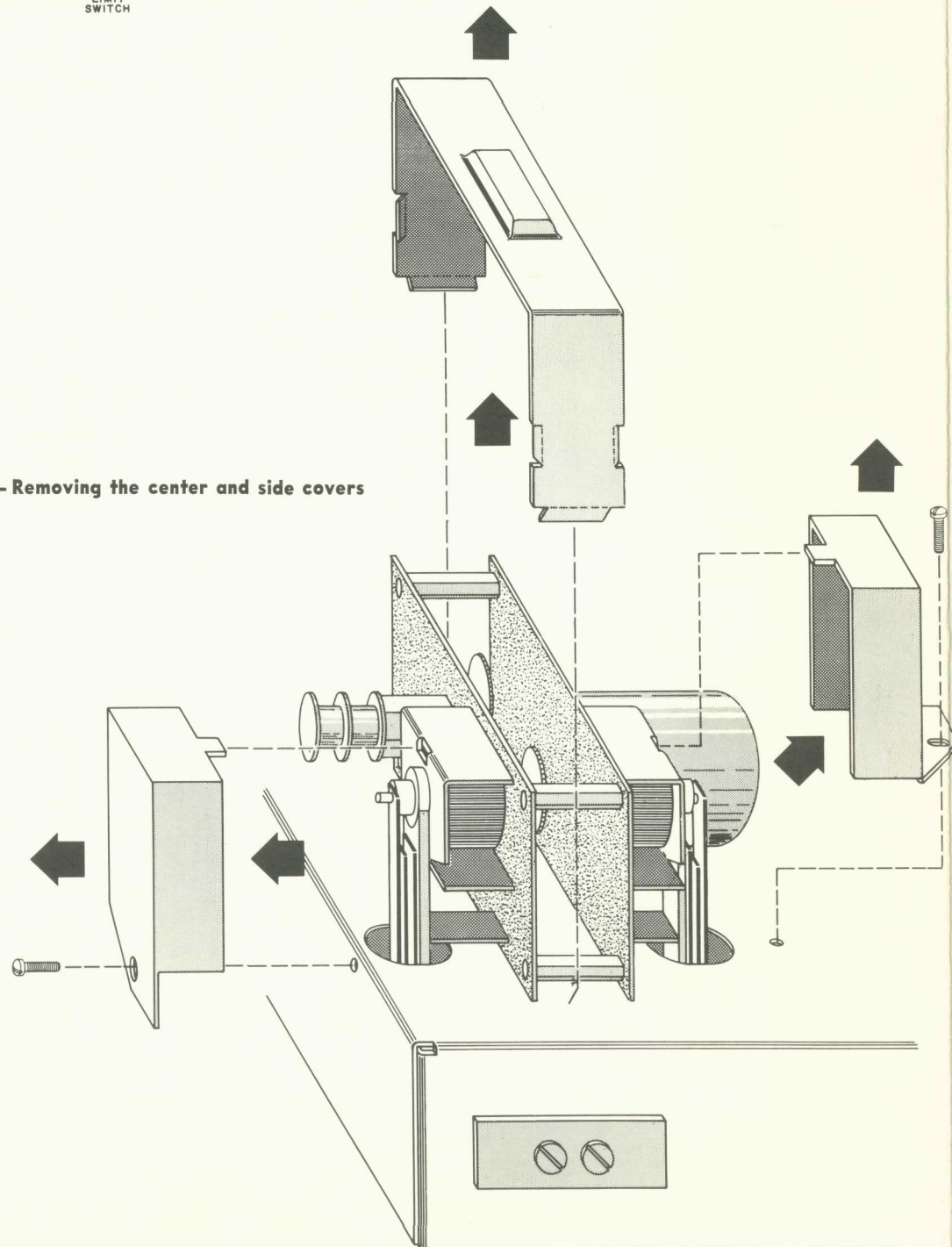
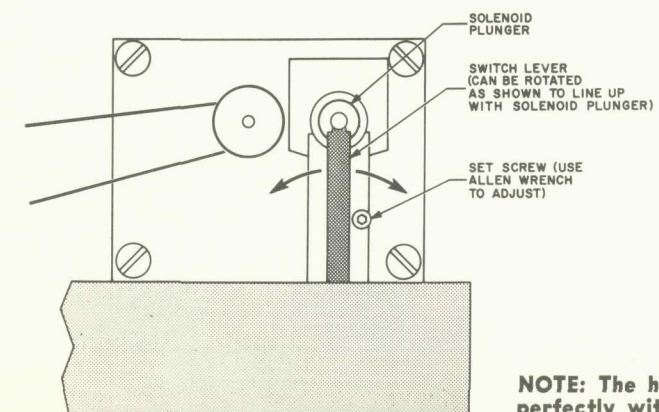
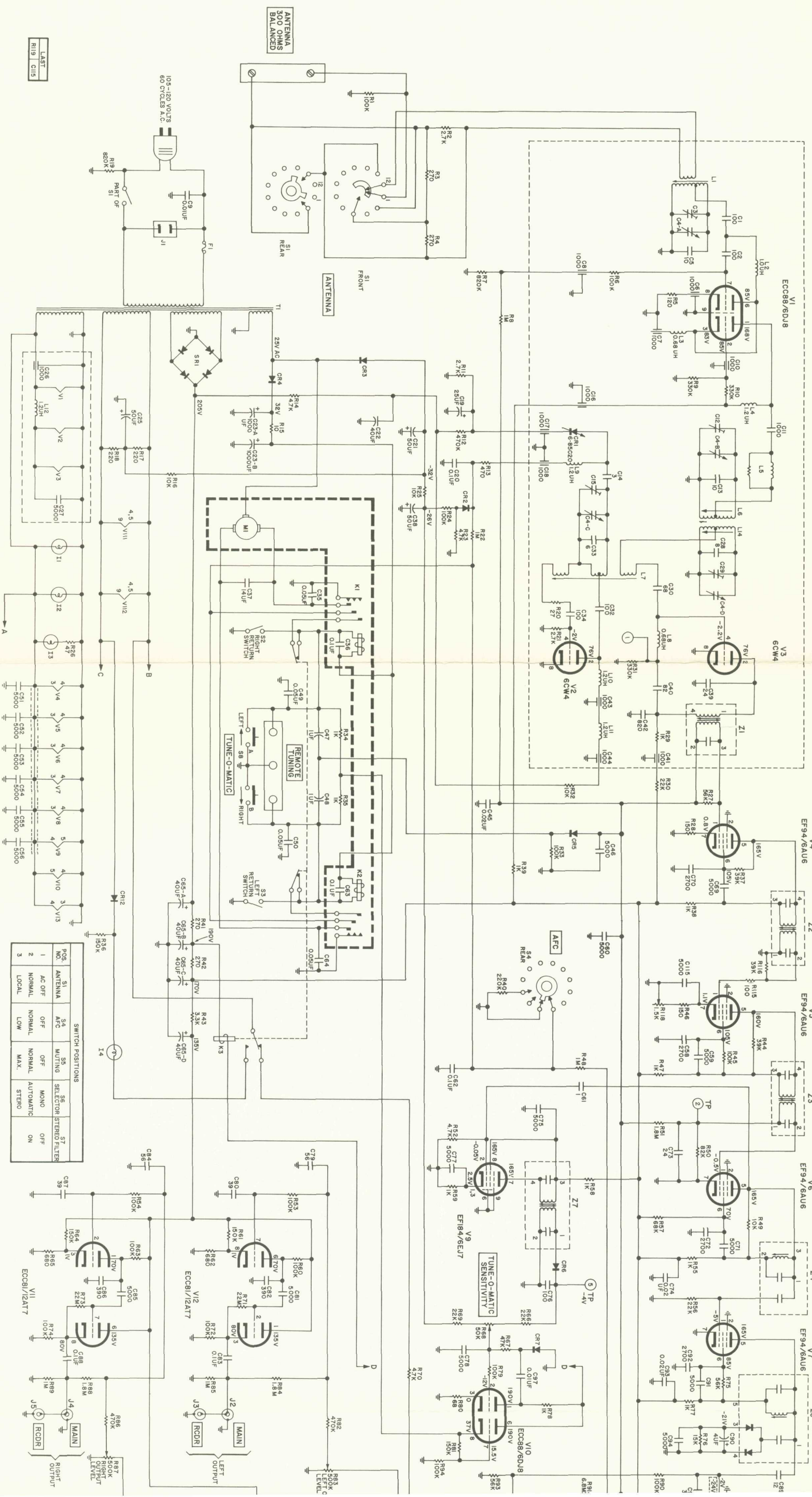

FIGURE 5 — Motor drive assembly, side view



NOTE: The hole in the switch lever must line up perfectly with the post on the solenoid plunger.

SCHEMATIC DIAGRAM • TUNER



SWITCH POSITIONS

POS. NO.	S1	S4	S5	S6	S7
1	AC OFF	OFF	MULTING	OFF	MONO
2	NORMAL	NORMAL	OFF	NORMAL	OFF
3	LOCAL	LOW	MAX.	STEREO	ON

LAST
R119 C115

SCHEMATIC DIAGRAM • PREAMPLIFIER

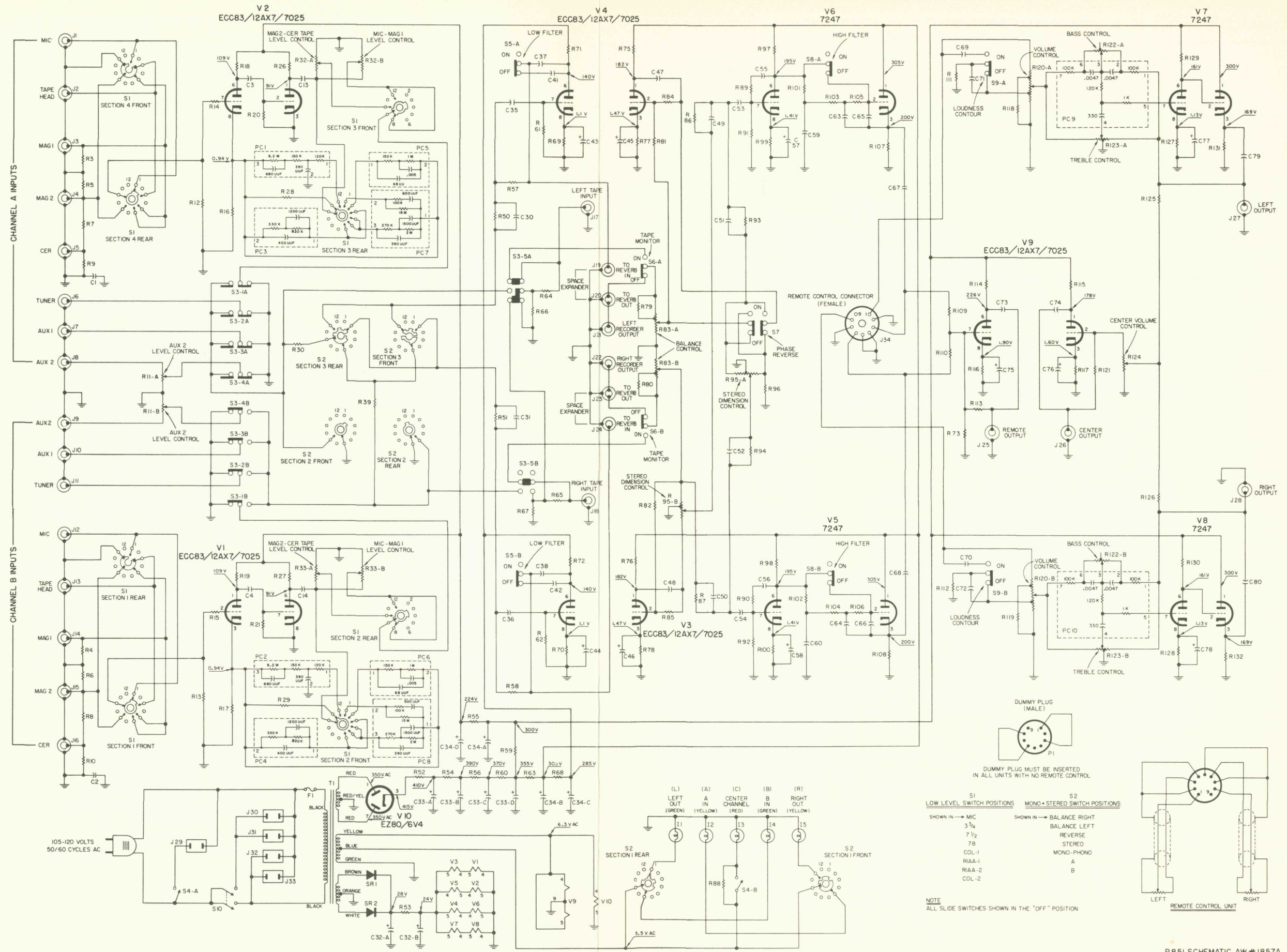

RESISTORS	R3 TO R10	R11	R12 TO R17	R18 TO R19	R20 TO R21	R26 TO R30	R32 TO R33	R39	R52 TO R53	R54	R55 TO R56	R50 R57 TO R60	R61 TO R63	R64 TO R70	R71	R75 TO R80	R81 TO R85	R86 TO R87	R88	R89 TO R95	R96 TO R100	R101 TO R102	R103 TO R104	R105 TO R106	R107 TO R108	R73 TO R113	R109 TO R116	R114 TO R118	R119	R120 TO R123	R124	R125 TO R126	R127 TO R130	R131 TO R132
CAPACITORS	C1 TO C2		C3 TO C4		C4	C13 TO C14			C32 TO C33	C34	C30 TO C31	C35 TO C36	C37 TO C38	C41 TO C44		C45 TO C46	C47 TO C48	C49 TO C50	C51 TO C54	C55 TO C56	C57 TO C58	C59 TO C60	C63 TO C64	C65 TO C66	C67 TO C68	C69 TO C72	C73 TO C75	C74	C76 TO C77	C78	C79 TO C80			

DUMMY PLUG (MALE)
P1

DUMMY PLUG MUST BE INSERTED IN ALL UNITS WITH NO REMOTE CONTROL

LOW LEVEL SWITCH POSITIONS
SHOWN IN → MIC

MONO-STEREO SWITCH POSITIONS
SHOWN IN → BALANCE RIGHT

NOTE
ALL SLIDE SWITCHES SHOWN IN THE "OFF" POSITION

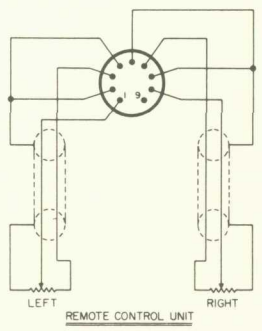

SCHEMATIC DIAGRAM • POWER AMPLIFIER

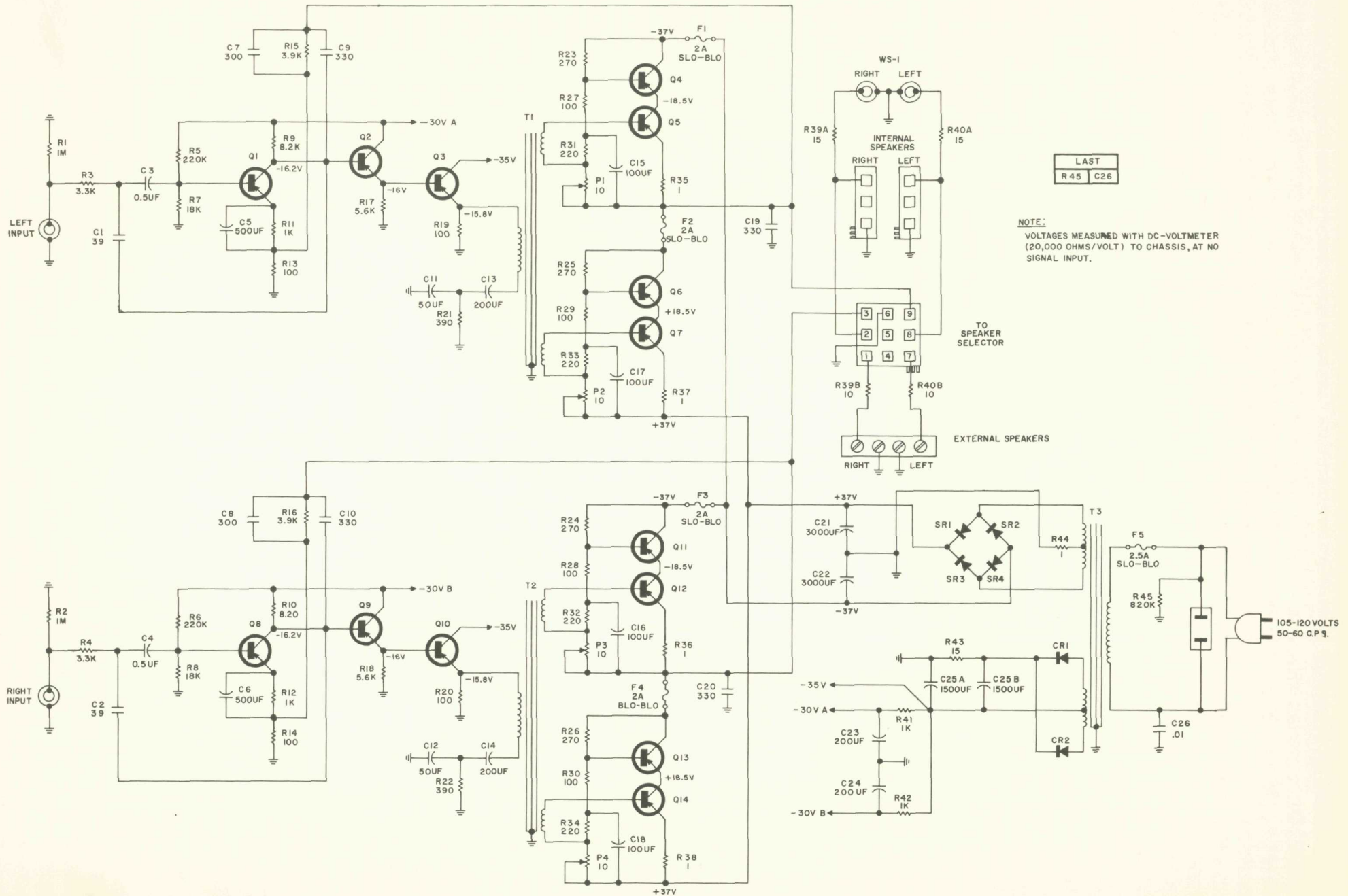

LAST
R 45 C 26

NOTE:
VOLTAGES MEASURED WITH DC-VOLTMETER
(20,000 OHMS/VOLT) TO CHASSIS, AT NO
SIGNAL INPUT.

TO
SPEAKER
SELECTOR

EXTERNAL
SPEAKERS

105-120 VOLTS
50-60 C.P.S.

PARTS DESCRIPTION LIST • REMOTE CONTROL

CAPACITORS

10% tolerance for all fixed capacitors, unless otherwise noted or marked GMV (guaranteed minimum value). All capacitors not marked uf are pF (uuf).

Symbol	Description	Part No.
C7	Electrolytic, 1000uf, 15V	C50283-10
C8	Electrolytic, 250uf, 25V	C50283-11
C14	Electrolytic, 100uf, 25V	C643-145
C15, 16	Electrolytic, 1uf, 50V	C746-144
C17	Ceramic, .05uf, +80 -20%, 100V	C50073-2
C18	Electrolytic, 4uf, 50V	C629-175
C19	Electrolytic, 100uf, 25V	C643-145
C20	Electrolytic, 2uf, 70V	C721-142
C21	Molded, .01uf, 20%, 600V	C2747
C22, 23	Ceramic, .02uf, GMV, 1000V	C50071-6

RESISTORS & POTENTIOMETERS

In ohms, 5% tolerance, 1/8 watt unless otherwise noted. K=Kilohms, M=Megohms.

Symbol	Description	Part No.
R12	Dep. Carbon, 47, 5%, 1/8 W	R12DC470J
R13	Dep. Carbon, 47K, 5%, 1/8 W	R12DC473J
R14	Dep. Carbon, 22K, 5%, 1/8 W	R12DC223J
R15	Potentiometer, Dual, 250K, R854-133	Part of Motor Pot. Assembly
R16	Dep. Carbon, 47K, 5%, 1/8 W	R12DC473J
R17	Dep. Carbon, 22K, 5%, 1/8 W	R12DC223J
R20	Dep. Carbon, 47, 5%, 1/8 W	R12DC470J

R21	Dep. Carbon, 100K, 5%, 1/8 W	R12DC104J
R22	Dep. Carbon, 4.7K, 5%, 1/8 W	R12DC472J
R23	Dep. Carbon, 33K, 5%, 1/8 W	R12DC333J
R24	Dep. Carbon, 2.2K, 5%, 1/8 W	R12DC222J
R25	Dep. Carbon, 3.3K, 5%, 1/8 W	R12DC332J
R26	Dep. Carbon, 10K, 5%, 1/8 W	R12DC103J
R27	Composition, 1K, 10%, 1/2 W	RC20BF102K
R28	Composition, 10, 10%, 1/2 W	RC20BF100K

MISCELLANEOUS

Symbol	Description	Part No.
CR1, 2	Diode, Silicon, Type 1112	V-1112
I1	Lamp, Volume Indicator	150461-1
K1	Relay, Tuning	K50437

K2	Relay, Reverse	K50436
K3	Relay, Volume	K50437
M	Motor Potentiometer Assembly	AS854-125
S1	Switch, Pushbutton	S854-130
S2	Switch, Power	Part of Motor Pot. Assembly
SR1	Selenium Rectifier Bridge	SR755-140
T1	Transformer, Power	T854-116
—	Assembled Printed Circuit Board	AS854-132
—	Dress Panel	AS854-108
—	Knob	E50325-1
—	Remote Control Transmitter	P-853
—	4V Battery	BA853-111
—	RK-15 Wire Remote Control	P-1086

SCHEMATIC DIAGRAM • REMOTE CONTROL

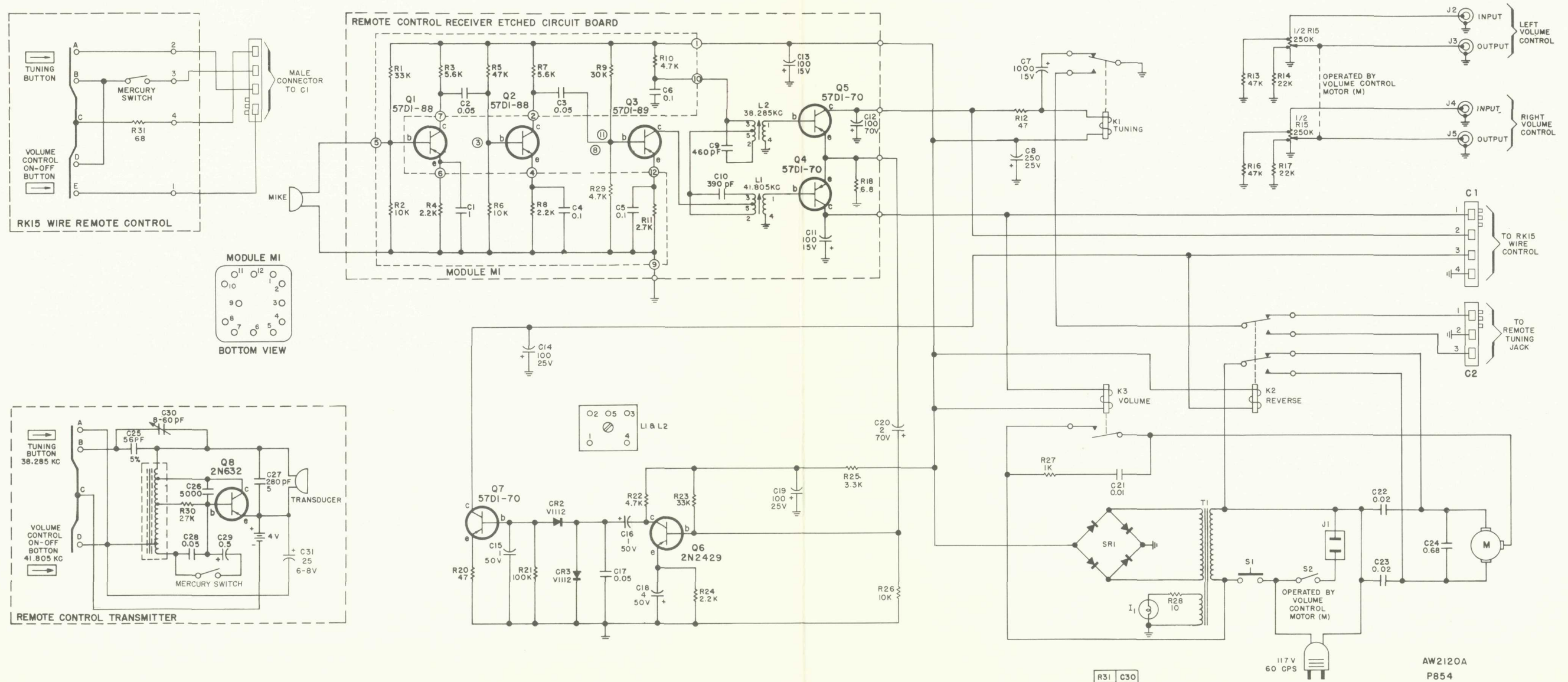

ALIGNMENT INSTRUCTIONS • REMOTE CONTROL

transmitter checkout

1 — Tilt the transmitter (hand-held unit) to the left and press the VOL pushbutton. Hold the metallic grille screen close to the ear and listen for a buzzing sound.

2 — While depressing the VOL button, tilt the transmitter to the right. The buzzing should stop.

3 — Repeat steps 1 and 2 while pressing the TUNE pushbutton.

4 — If the buzzing sound is not heard, replace the battery (Mallory TR-163 or equivalent). **DO NOT** attempt to align or adjust the transmitter if proper operation is not restored after replacement of the battery. Specially designed test equipment is needed for this alignment. Return the defective transmitter to SERVICE DEPARTMENT, FISHER RADIO CORPORATION, 21-21 44th Drive, L.I.C. 1, N. Y.

receiver checkout

EQUIPMENT NEEDED: Oscilloscope (use a low capacitance probe or a 47K ohm resistor in series with the "hot" lead), a transistor radio alignment tool (with square head).

1 — Connect the oscilloscope lead to the base (b) of transistor Q5. Connect the other lead to chassis ground.

2 — From a distance of about three feet, aim the remote control away from the metal grille on the receiver chassis. Tilt the remote control to the right and press the TUNE pushbutton. Leave the transmitter in a position which produces minimum signal and minimum flutter of the signal as observed on the oscilloscope.

3 — Using the alignment tool, adjust L2 for maximum average indication on the oscilloscope.

4 — Repeat steps 2 and 3 with the VOL button depressed and the oscilloscope connected to the

base (b) of Q4, aligning L1 for maximum signal indication on the oscilloscope.

5 — If the maximum indications on the oscilloscope for steps 3 and 4 differ by a factor of 2 or more, return the **transmitter only** to the factory for alignment.

6 — To check the operation of the relays, press the TUNE button, and tilt the transmitter to the right. Observe that the relay in the middle of the three relays (located on top of the receiver chassis) operates. Tilt the transmitter to the left, keeping the TUNE button depressed. The center and rear relay (as viewed from the front) should both operate. Press the VOL button, tilting the transmitter to the right and observe that the front relay operates. Then tilt to the left while depressing the VOL button and observe that the rear and front relays operate.

7 — As a final operating check, connect the receiver into the system, stand about 20 feet from the receiver and press the TUNE button of the transmitter while tilting the unit alternately to the left and right. Observe correct tuning action of the tuner. Then press the VOL pushbutton while tilting the transmitter to the left and then the right. Observe rotation of the receiver Volume control and alternate raising and lowering of the sound output of the amplifier to which the receiver is connected.

*If the tuner is not available for this tuning check, connect an ohmmeter across pins 1 and 2 (see schematic) of the jack marked TO REMOTE TUNING JACK. Zero resistance should be indicated when the TUNE button is depressed and the transmitter is tilted to the right. With the TUNE button depressed and the transmitter tilted to the left, a zero resistance should be indicated between pins 2 and 3. To check the operation of the VOL button, it is best to connect the receiver into the system (see the Operating Instructions) and observe proper operation with a musical or voice signal.

If replacement parts are out of stock, locally, they may be obtained directly from the Parts Department of FISHER Radio Corporation. They will be shipped "best way", either prepaid or C.O.D. unless otherwise specified.

For instrument-operation information and technical assistance write Richard Hamilton, Customer Service Department, FISHER Radio Corporation, Long Island City, New York 11101.

SCHEMATIC DIAGRAM • AUTOMATIC SHUT-OFF ASSEMBLY

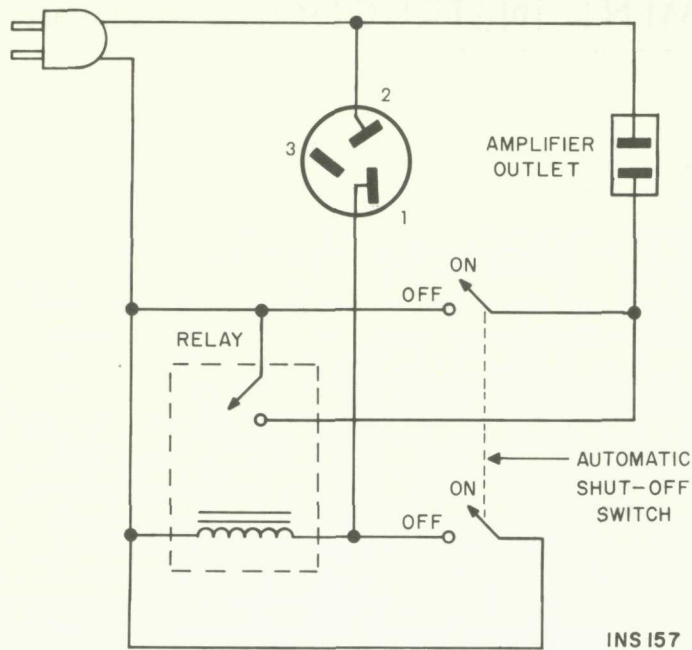

988-115-1

INS 157

SCHEMATIC DIAGRAM • SPEAKER SYSTEMS

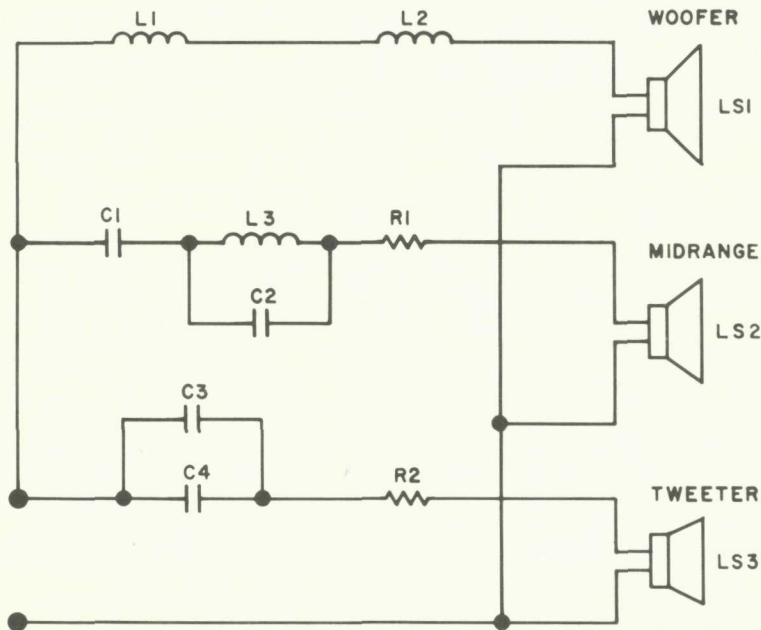

INS 304

PARTS DESCRIPTION LIST

C1	Capacitor, 50 μ F, nonpolarized	C350
C2, 3	Capacitor, 1 μ F, nonpolarized	C301
C4	Capacitor, 2 μ F, nonpolarized	C302
L1	Inductor	L214
L2, 3	Inductor	L220
LS1	Woofer, 15-inch	W123
LS2	Mid-range, 8-inch	M124X
LS3	Tweeter, Dome	G101C
R1, 2	Resistor, 9 \cdot ohms	R409

TUBE LAYOUT • TUNER

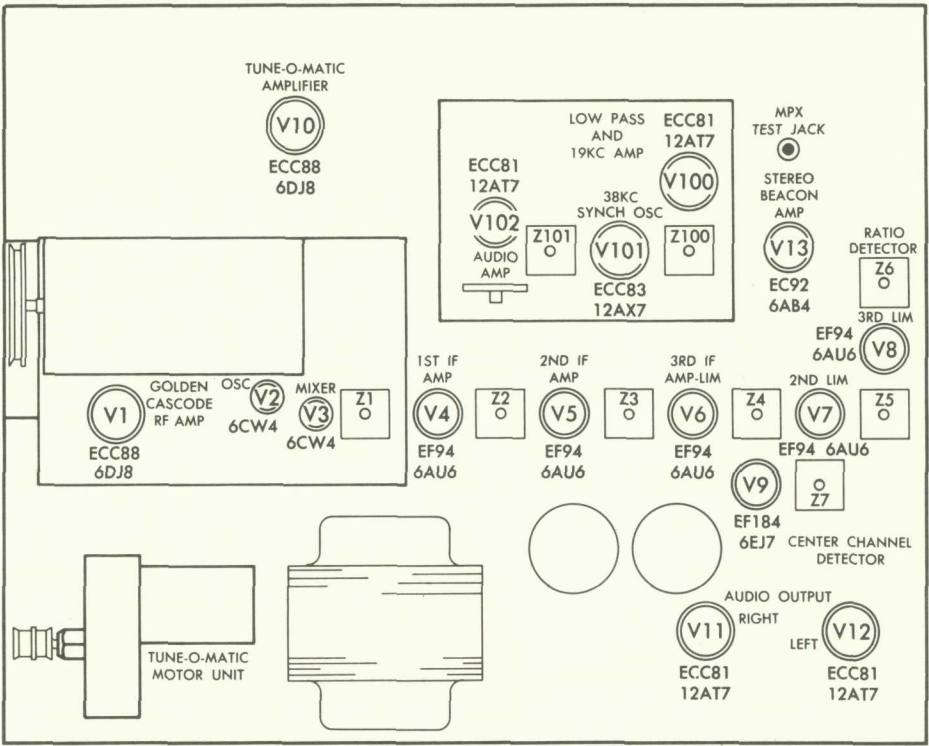

INS 156

TUBE LAYOUT • PREAMPLIFIER

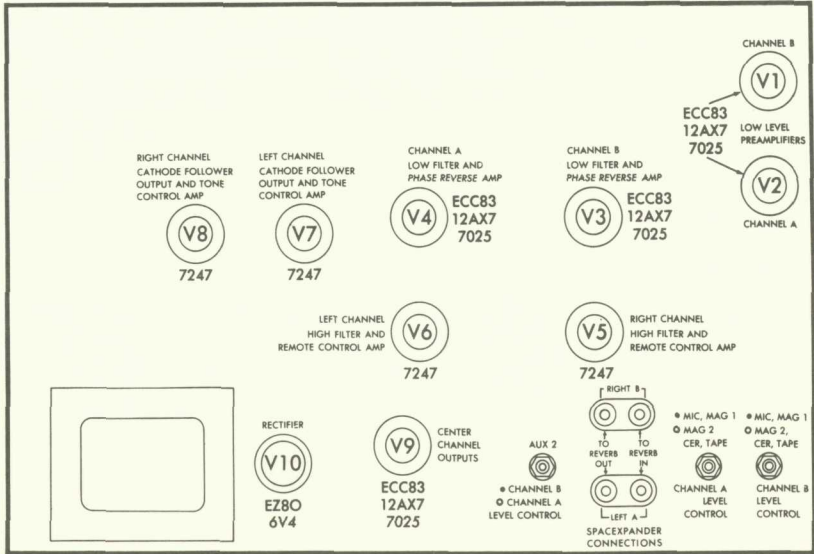

AW 1851A

SERVICE POINTS

General

One should always be careful when working with transistors, since they may be destroyed almost instantly. This is in marked contrast to tubes, which can usually bear moderate overloads for longer periods.

Special Precautions

Observe the following precautions when servicing transistor equipment:

- Never work on a transistor amplifier without first disconnecting it from its source of power.
 - Guard against shorts — one of even brief duration between the collector and base of any transistor will destroy that transistor, and often those associated with it (as in the case of Darlington-connected transistors, or those in the single-ended push-pull output stage of the power amplifier). Such shorts may be produced even in the short time it takes for a dropped screwdriver to glance off a pair of socket terminals, or between terminals and chassis.
 - Damage will occur to **any** transistor in the amplifier if its base is placed at or near the same potential as the collector. Such a condition might occur if transistor Q1 were open (blowing Q2), or resistor R7 were open (blowing Q1).
 - All of the output transistors in one channel will be destroyed if the base leg of the biasing circuit is open on the emitter side.
 - If one output transistor burns out, always remove **all** output transistors in that channel, and check the bias adjustment controls and the other parts involved in the biasing network with an ohmmeter before inserting a new transistor.
 - If transistor replacement is necessary, be sure the replacement is of the same type. For output and driver transistors (Q3 through Q6, and Q-10 through Q-14), replacements should also be from the same beta group. The group is indicated by a colored dot on the mounting flange. Be sure to specify this color when ordering replacements.
 - When mounting new power transistors, be sure that heat sinks and mica insulators are free from metal shavings, which might cause shorts, or prevent good heat transfer from transistor to heat sink.
 - Use silicon grease between heat sink and mica insulators, as well as between mica insulators and transistors, for better heat conduction.
- Use one of the following types of grease:
- Dow-Corning No. 3 compound
 - Dow-Corning No. C20194 compound
- Do **not** use an ohmmeter for testing transistors, since the voltage they apply during testing may exceed the transistor's base-emitter breakdown voltage.

Instructions For Balancing Transistor Output Stage

- 1 — Remove power from the unit.
- 2 — Connect an 8-ohm load, a DC VTVM and the input of an IM distortion analyzer across the hot and ground contacts of the left INT SPKR output. Check that you have not shorted the amplifier output.
- 3 — Connect the output of the IM distortion analyzer to the left input.

4 — Switch the amplifier on and adjust the output of the distortion analyzer until the output, as measured across the load, is 5 watts.

5 — Adjust P1 and P2 for minimum IM distortion and zero DC across the load. The use of two screwdrivers in this procedure will save time.

6 — Repeat steps (2) through (5), after attaching the test equipment to the corresponding points on the right channel, and adjust P3 and P4 for zero DC and minimum IM distortion, as described above.

Additional Equipment Required for Servicing Transistor Equipment

A word of caution is in order about testing transistors. While most test equipment used for repairing vacuum tubes may be used to test transistors and transistorized equipment, the serviceman should be sure there are no leakage paths for line voltage in the equipment, since line voltage applied across two terminals of a transistor could cause transistor breakdown. Let us emphasize that **ohmmeters should not be used to test transistors**, since their test voltage may exceed the transistor's breakdown voltage, and therefore destroy the transistor. Instead, we recommend that a high-quality transistor tester, such as the Hickok model 870, be used.

It is also advisable for the serviceman to purchase a low-wattage soldering iron and a soldering aid for use with transistorized equipment. Again, he should make sure there is no internal leakage path to the line in his soldering iron.

Quick Transistor Tester

If a transistor tester is not available, and a quick, but not comprehensive test is desired, the tester shown in figure 1 may be constructed and utilized to determine the transistor's DC beta.

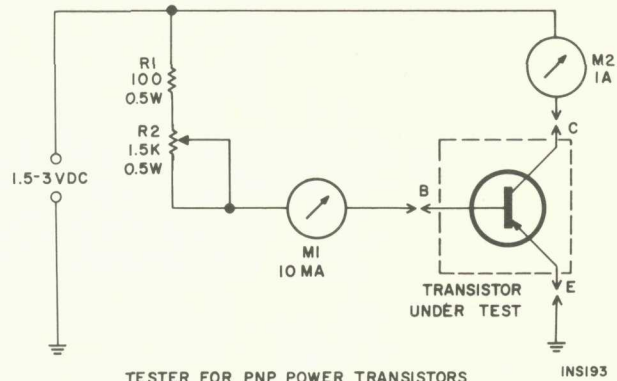

TESTER FOR PNP POWER TRANSISTORS

FIG. 1

Install the transistor in the tester and adjust resistor R2 for 0.5 amperes in the collector circuit, as indicated by M2. Calculate the beta as follows:

$$\text{Beta} = \frac{\text{reading of M2}}{\text{reading of M1}}$$

The beta should be between 50 and 250.



FISHER RADIO CORPORATION • NEW YORK