

THE FISHER R-30-S
SCHEMATIC and
PARTS LIST

USED IN:

Normandy II Series, Model N710
Contemporary II Series, Model C810
Provence II Series, Model P410

CHASSIS SERIAL NUMBERS
10001-39999 INCLUSIVE

PRICE: \$1.00

FISHER RADIO CORPORATION · NEW YORK

PARTS DESCRIPTION LIST

CAPACITORS

20% tolerance for all fixed capacitors, unless otherwise noted or marked GMV (guaranteed minimum value.) Cer = Ceramic

Symbol	Description	Part No.
C1	Ceramic, 2mmf NPO, 500V	CC20CH020D5
C2	Ceramic, 5mmf NPO, 500V	CC20CH050K5
C3	Variable, FM-AM tuning	C643-117
C4	Ceramic, 220mmf 10%, 500V	CC21GP221K5
C5	Ceramic, .02mf +80% -20%, 600V	C50071-3
C6, 7	Ceramic, 100mmf GMV, N1500, 1000V	C50070-5
C8	Ceramic, 8mmf ±.25mmf, N1400, 500V	CC20VK080K5
C9, 10	Ceramic, .005mf 20%, 500V	C50089-1
C11		
C12	Ceramic, 180mmf 10%, 500V	CC21GP181K5
C13	Ceramic, 24mmf N150, 500V	CC20PJ240K5
C14, 15	Ceramic, .005mf 20%, 500V	C50089-1
C16	Ceramic, 47mmf, N750, 500V	CC20UJ470K5
C17	Molded, .047mf 10%, 250V	C50074-27
C18, 19	Ceramic, .005mf 20%, 500V	C50089-1
C20	Ceramic, 220mmf 10%, 500V	CC21GP221K5
C21	Ceramic, 330mmf 10%, 1000V	C50072-1
C22	Ceramic, 1000mmf 10%, 1000V	C50072-3
C23, 24	Ceramic, 330mmf 10%, 1000V	C50072-1
C25	Electrolytic, 8mf, 50V	C629-138
C26, 27	Ceramic, 24mmf N150, 500V	CC20PJ240K5
C28	Molded, .022mf 10%, 500V	C50074-36
C29	Electrolytic, 100mf, 25V	C643-145
C30	Molded, .022mf 10%, 500V	C50074-36
C31	Ceramic, 24mmf N150, 500V	CC20PJ240K5
C32	Molded, .022mf 10%, 250V	C50074-26
C33	Molded, .1mf 10%, 250V	C50074-28
C34	Not Used	
C35	Ceramic, 24mmf N150, 500V	CC20PJ240K5
C36	Molded, .1mf 10%, 250V	C50074-28
C37	Electrolytic, 10mf, 350V	C644-146
C38	Ceramic, feedthru, 1000mmf GMV	C629-172
C39	Ceramic, 24mmf N150, 500V	CC20PJ240K5
C40	Ceramic, 47mmf N750, 500V	CC20UJ470K5
C41	Ceramic, .005mf, 500V	C50089-1
C42	Ceramic, 100mmf 10% N1500, 1000V	C50070-6
C43	Ceramic, 1000mmf 10%, 1000V	C50072-3
C44	Ceramic, feedthru, 1000mmf GMV	C629-172
C45	Ceramic, 68mmf N750, 500V	CC20UJ680K5
C46	Ceramic, 10mmf N330, 500V	CC20SH100D5
C47	Ceramic, Trimmer, 1.8mmf NPO	C643-153
C48, 49	Ceramic, 100mmf GMV N1500, 1000V	C50070-5
C50	Ceramic, feedthru, 1000mmf GMV	C629-172
C51	Ceramic, 18mmf NPO, 500V	CC20CH180K5
C52, 53	Ceramic, 100mmf GMV N1500, 1000V	C50070-5
C54	Ceramic, feedthru, 1000mmf GMV	C629-172
C55	Ceramic, 8mmf NPO, 500V	CC20CH080D5
C56	Ceramic Trimmer, 1.8mmf NPO	C643-153
C57	Ceramic, 1000mmf 10%, 1000V	C50072-3
C58	Molded, .0068mf 10%, 200V	C68P682K2
C59	Ceramic, .02mf +80% -20%, 600V	C50071-3
C60	Ceramic, 100mmf 10% N1500, 1000V	C50070-6
C61	Molded, .1mf 10%, 250V	C50074-28
C62	Molded, .0039mf 10%, 200V	C68P392K2
C63	Ceramic, 1000mmf 10%, 1000V	C50072-3
C64	Molded, .01mf 10%, 250V	C50074-25
C65	Electrolytic, 10mf, 350V	C644-146
C66	Ceramic, .02mf +80% -20%, 600V	C50071-3
C67	Molded, .0068mf 10%, 200V	C68P682K2
C68	Electrolytic; four section, 40mf, 450V 40mf, 350V 40mf, 350V 20mf, 300V	C643-138

C69	Ceramic, 100mmf 10% N1500, 1000V	C50070-6
C70	Molded, .1mf 10%, 250V	C50074-28
C71	Molded, .0039mf 10%, 200V	C68P392K2
C72	Ceramic, 1000mmf 10%, 1000V	C50072-3
C73	Molded, .01mf 10%, 250V	C50074-25
C74	Ceramic, feedthru, 1000mmf GMV	C629-172
C75	Ceramic, .005mf, 500V	C50089-1
C76	Molded, .01mf, 600V	C2747
C77	Ceramic, 820mmf 5%, 500V	CC21GP821J5

RESISTORS AND POTENTIOMETERS

In ohms, 10% tolerance, 1/2 watt, unless otherwise noted. K = kilohm, M = megohm.

Symbol	Description	Part No.
R1	Composition, 820K	RC20BF824K
R2	Composition, 33K	RC20BF333K
R3	Composition, 33K, 1W	RC30BF333K
R4	Composition, 82K, 1W	RC30BF823K
R5	Composition, 100	RC20BF101K
R6	Composition, 82K	RC20BF823K
R7	Composition, 1K	RC20BF102K
R8	Composition, 100	RC20BF101K
R9	Composition, 47K, 1W	RC30BF473K
R10	Composition, 1K	RC20BF102K
R11	Composition, 2.2M	RC20BF225K
R12	Composition, 180K	RC20BF184K
R13	Composition, 22K	RC20BF223K
R14	Composition, 1.5K	RC20BF152K
R15	Composition, 100K	RC20BF104K
R16	Composition, 82K	RC20BF823K
R17	Composition, 1K	RC20BF102K
R18	Composition, 270	RC20BF271K
R19	Composition, 68K	RC20BF683K
R20	Composition, 1K	RC20BF102K
R21	Composition, 680K	RC20BF684K
R22	Composition, 15K	RC20BF153K
R23	Potentiometer, 250K 20%	R50103-1
R24	Composition, 1.5K	RC20BF152K
R25	Composition, 27K	RC20BF273K
R26	Composition, 100K	RC20BF104K
R27	Composition, 2.2K	RC20BF222K
R28	Composition, 820K	RC20BF824K
R29	Wirewound, 130 5% 5W	R644-147
R30	Composition, 33K	RC20BF333K
R31	Composition, 100K	RC20BF104K
R32	Composition, 820K	RC20BF824K
R33	Not Used	
R34	Composition, 100K	RC20BF104K
R35	Composition, 470K	RC20BF474K
R36	Composition, 10M	RC20BF106K
R37	Composition, 220K	RC20BF224K
R38	Composition, 680K	RC20BF684K
R39	Composition, 15K	RC20BF153K
R40	Potentiometer Dual, 500K 20%	R644-140
R41	Composition, 1M	RC20BF105K
R42	Composition, 10M	RC20BF106K
R43	Composition, 47K	RC20BF473K
R44	Composition, 470	RC20BF471K
R45	Composition, 1M	RC20BF105K
R46	Composition, 3.3K, 2W	RC40BF332K
R47	Composition, 4.7K, 2W	RC40BF472K
R48	Composition, 470K	RC20BF474K
R49	Composition, 1K	RC20BF102K
R50	Composition, 10	RC20BF100K
R51	Composition, 1.5K	RC20BF152K
R52	Composition, 47K	RC20BF473K
R53, 54	Composition, 470K	RC20BF474K
R55	Composition, 470	RC20BF471K

R56	Composition, 10M	RC20BF106K
R57	Composition, 33K	RC20BF333K
R58	Composition, 68K	RC20BF683K
R59, 60	Composition, 390K	RC20BF394K
R61	Composition, 1K	RC20BF102K
R62	Composition, 4.7K	RC20BF472K
R63	Potentiometer Dual, 1M 20%	R644-139
R64	Composition, 47K	RC20BF473K
R65	Composition, 220K	RC20BF224K
R66	Potentiometer Dual, 1M 20%	R644-139
R67	Wirewound, 1.8K, 7W	R643-144
R68	Wirewound, 600 5W	R643-157
R69, 70	Wirewound, 140 5W	R643-143
R71	Composition, 22K	RC20BF223K
R72	Composition, 15K	RC20BF153K
R73	Composition, 100K	RC20BF104K
R74, 75	Composition, 390K	RC20BF394K
R76	Composition, 1K	RC20BF102K
R77	Composition, 4.7K	RC20BF472K
R78	Composition, 47K	RC20BF473K
R79	Composition, 220K	RC20BF224K
R80	Composition, 22K	RC20BF223K
R81, 82	Potentiometer Wirewound, 500	R516-128
R83	Composition, 270	RC20BF271K
R84, 85		
86	Composition, 470K	RC20BF474K

COILS, TRANSFORMERS, CHOKES

Symbol	Description	Part No.
L1	Loopstick, AM Antenna	L644-121
L2	Choke, RF, 3.3 Micro H	L50066-8
L3	Choke, RF, 1 Micro H	L50066-2
L4	Coil, Tuned AM Oscillator	L643-140
L5	Choke, RF, 1 Micro H	L50066-2
L6	Choke, RF, .68 Micro H	L50066-1
L7, L8	Choke, RF, 1 Micro H	L50066-2
L9	Choke, RF, .68 Micro H	L50066-1
L10	Coil, Tuned FM Antenna	AS643-148
L11, 12	Choke, RF, 1 Micro H	L50066-2
L13	Coil, Tuned FM Oscillator	L643-151
L14	Choke, Assembly FM-RF	L629-180
L15	Coil, Tuned FM-RF	L643-150
L16	Coil, AM 10-kc Filter	L644-120
L17	Choke, Filament	L520-156
L18, 19		
20, 21	Choke, Ferrite Bead, Filament	L592-189
T1	Transformer, Output	T643-116
T2	Transformer, Power	T644-124
Z1	Transformer, Assembly AM-IF	ZZ2984
Z2	Transformer, Assembly FM-IF	ZZ630-114
Z3	Transformer, Assembly FM-IF	ZZ2987
Z4	Transformer, Assembly AM-IF	ZZ2984
Z5	Coil Assembly FM-AM IF	ZZ643-149
Z6	Transformer, Assembly FM Detector	ZZ592-170

MISCELLANEOUS

Symbol	Description	Part No.
CR1, 2	Crystal Diodes Matched Pair, FM Detector	V-1N542
F1	Fuse 2 Ampere, Slo-Blo	F643-154
I1	Lamp, Phono Compartment	I50084
	Note: Not used on some Models.	
I2, 3	Lamp, Dial Edge Lighting	I50082
S1	Channel Selector	S644-144
S2	Switch in Phono Compartment Light Socket	X50085
	Note: Not used on some Models.	
S3	Switch, AC Power	Part of R40

SCHEMATIC DIAGRAM

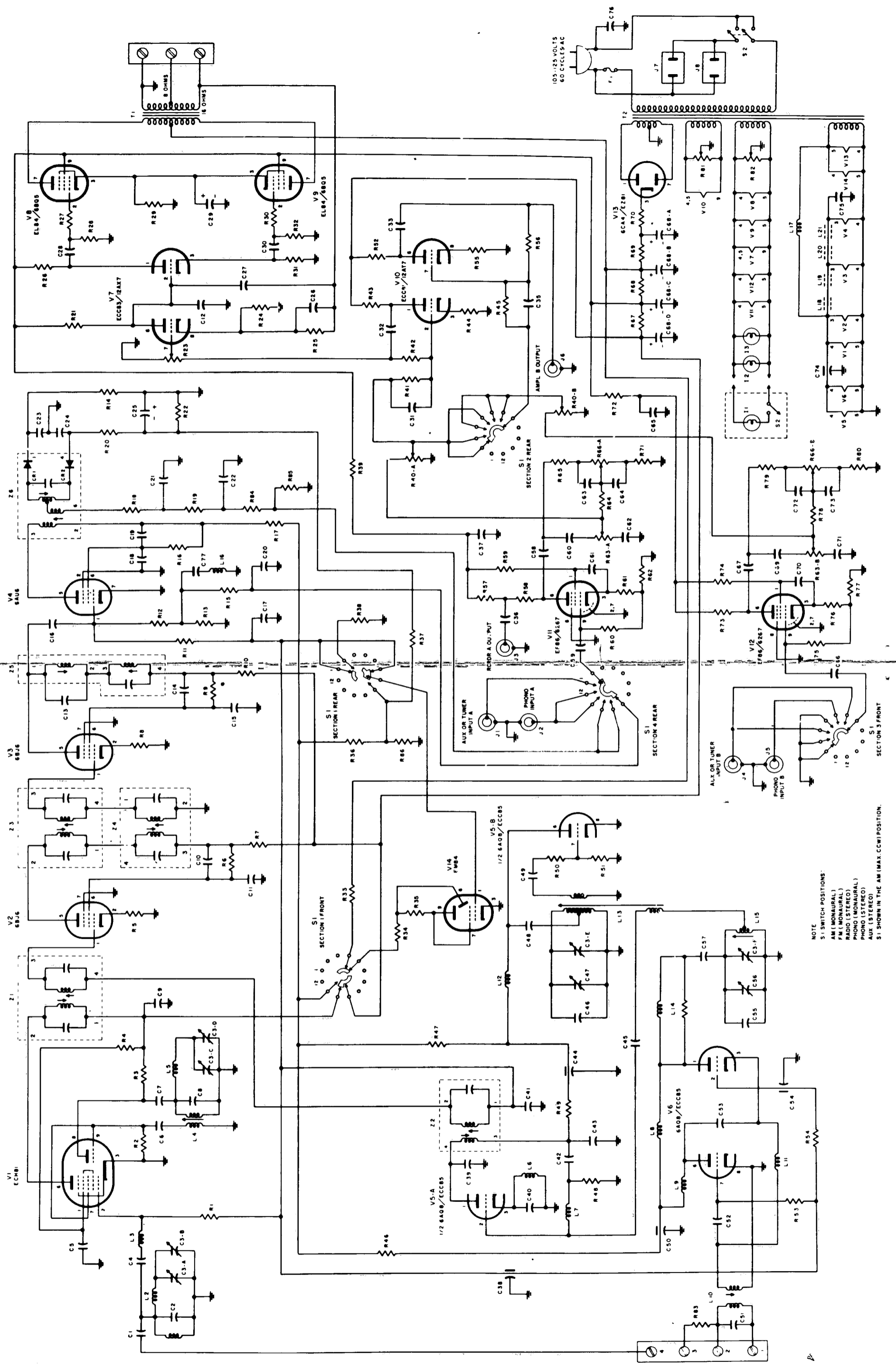

NOTE
 S1 SWITCH POSITIONS:
 AM (MONAURAL)
 FM (MONAURAL)
 RADIO (STEREO)
 PHONO (MONAURAL)
 PHONO (STEREO)
 AUX (STEREO)
 S1 SHOWN IN THE AM (MAX. CW) POSITION.



FISHER RADIO CORPORATION • NEW YORK

P644

Printed in U.S.A.

421W1C-30