

FISHER RC-80B TAPE CASSETTE DECK
SERVICE INFORMATION

The attached diagrams will provide information for servicing The Fisher RC-80B recorder until complete service manuals are available.

The RC-80B is an improved version of the 80 recorder. These diagrams supplement the service information provided in the RC-80 Service Manual, and should be used in conjunction with that manual.

To permit the high quality recording of which the RC-80B is capable various calibration and setup procedures must be performed. These are described on pages 3-7 of the RC-80 manual, and are supplemented by the Chromium Dioxide tape procedures detailed below.

ADJUSTMENT OF RECORDING BIAS FOR CHROMIUM DIOXIDE TAPE

1. Perform the Recording Bias Adjustment on page 6 of the RC-80 Service Manual.
2. In step (4) of that procedure use a blank chromium dioxide tape instead of standard iron oxide tape.
3. Perform steps (5) through (8), adjusting VR 10 and VR 9 (VR 207 and VR 107 in units below serial number 50,000) instead of VR 205 and VR 105.

ADJUSTMENT OF RECORD-PLAYBACK LEVEL ADJUSTMENT FOR CHROMIUM DIOXIDE TAPE

1. Perform the Record-Playback Level Adjustment for standard tape as detailed on page 6 of the RC-80 Service Manual.
2. In step (4) of that procedure use a blank chromium dioxide tape instead of iron oxide tape.
3. Perform steps (5) through (8), adjusting VR 8 and VR 7 (VR 208 and VR 108 in units below serial number 50,000) instead of VR 203 and VR 103.

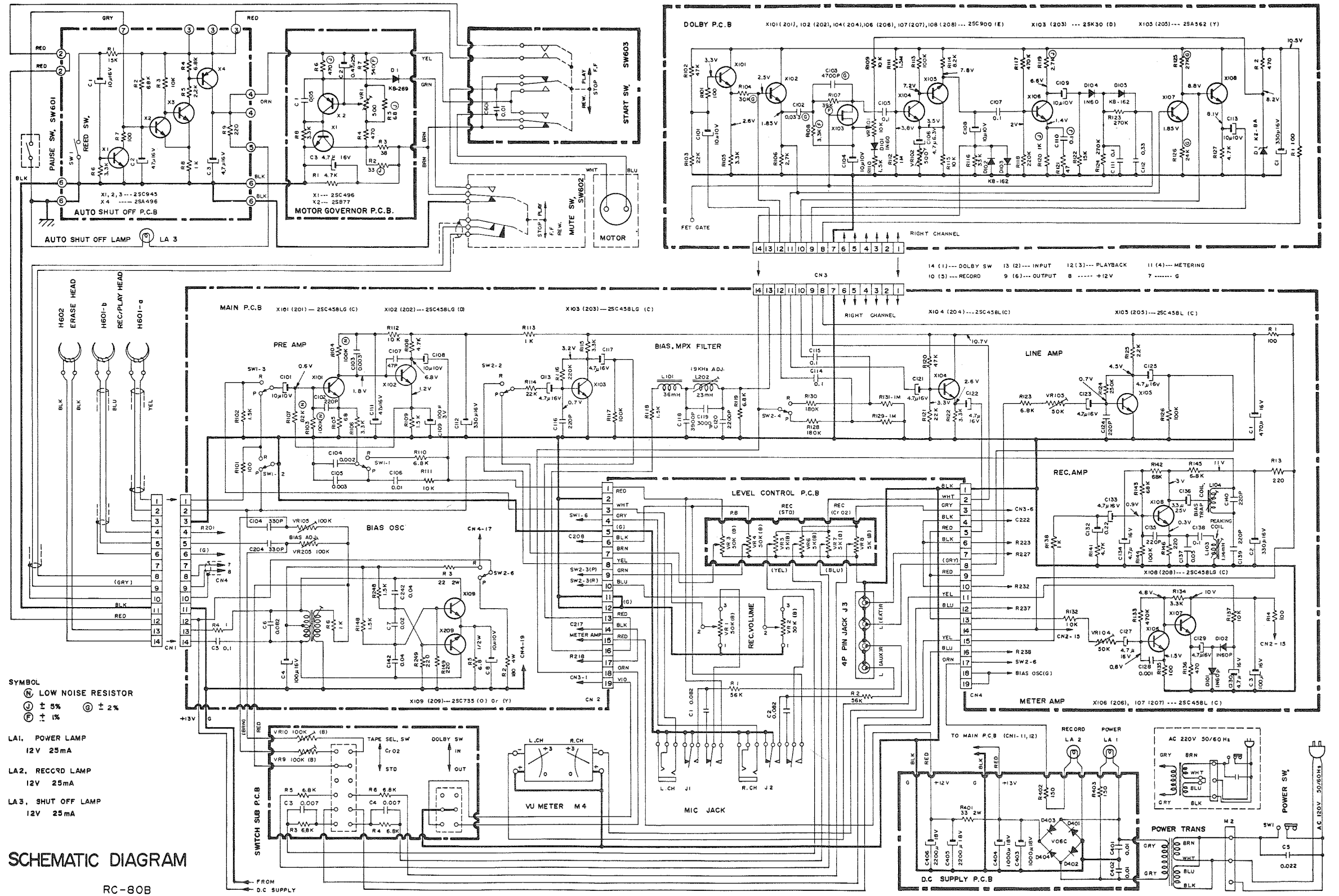

This diagram applies to recorders with serial numbers 50,000 and subsequent. Earlier serial numbers used slightly different values in place of those shown:

1. On the Power Supply Board the two 150 ohm resistors were previously 220 ohms.
2. The Record Volume Controls were 10 K instead of 50 K.
3. There were 220 ohm resistor across the Microphone Jacks.
4. The Aux Inputs had 100 K and 0.082 uF instead of 56 K and 0.056 uF.

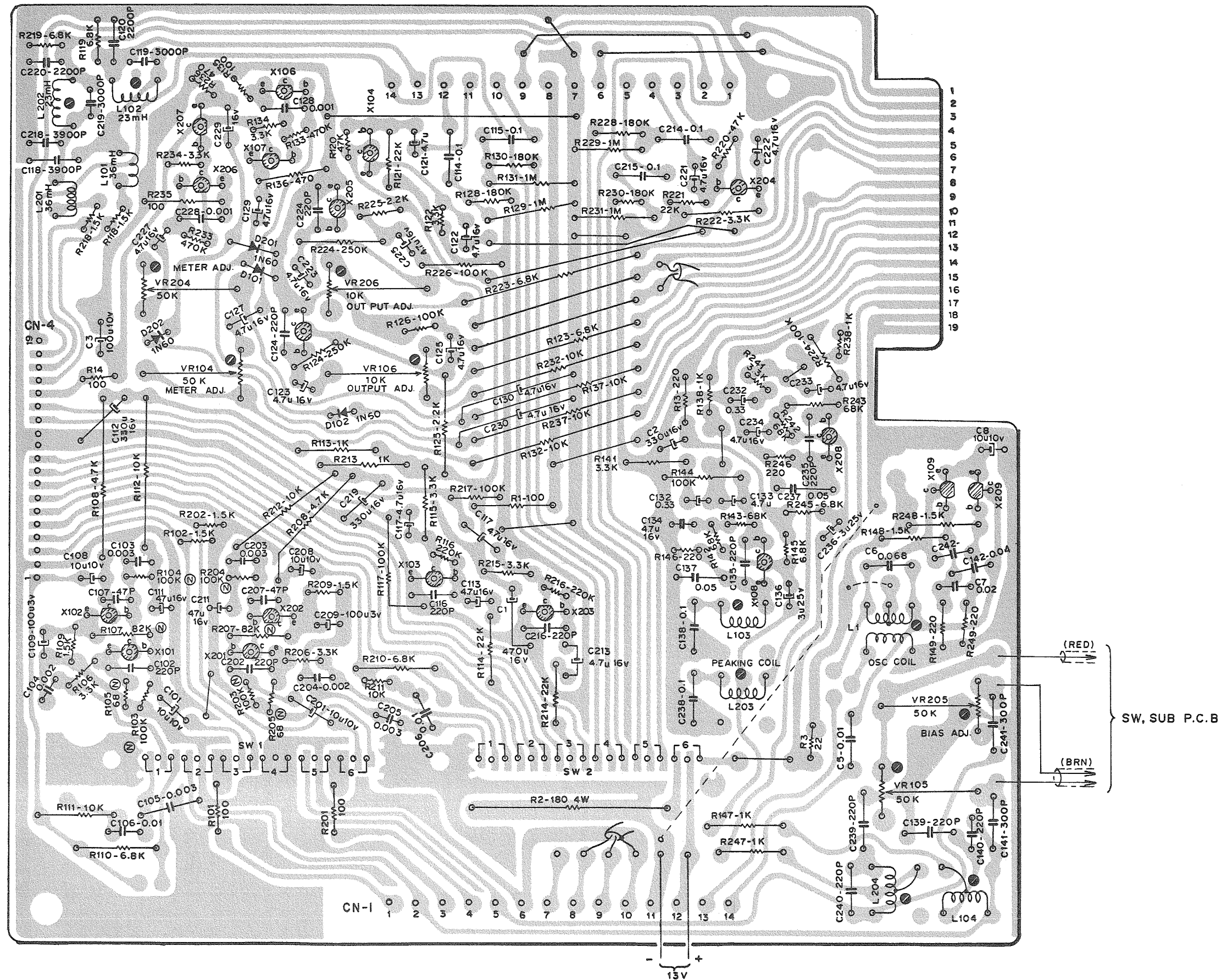

MAIN CIRCUIT BOARD

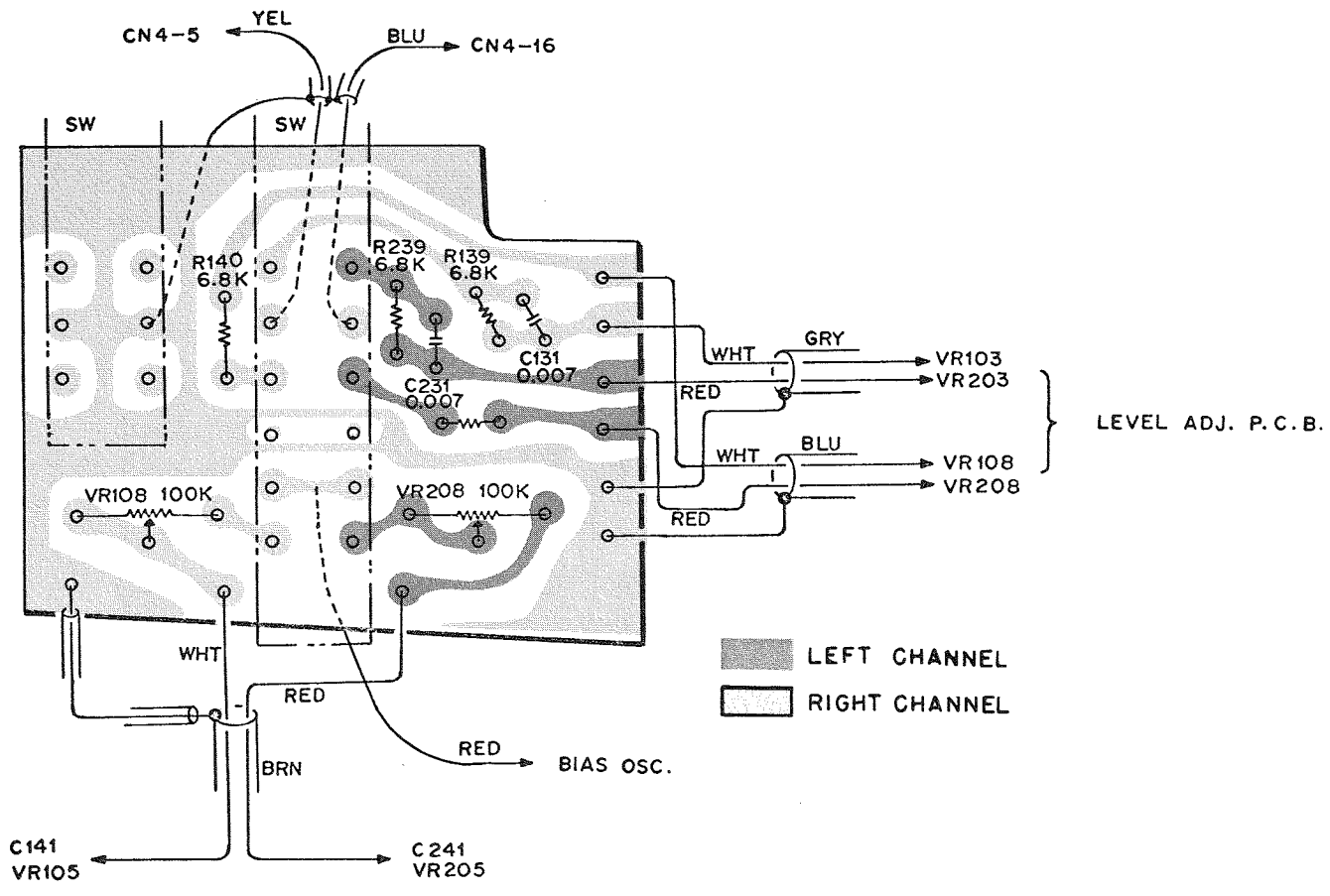

SWITCH SUB-BOARD

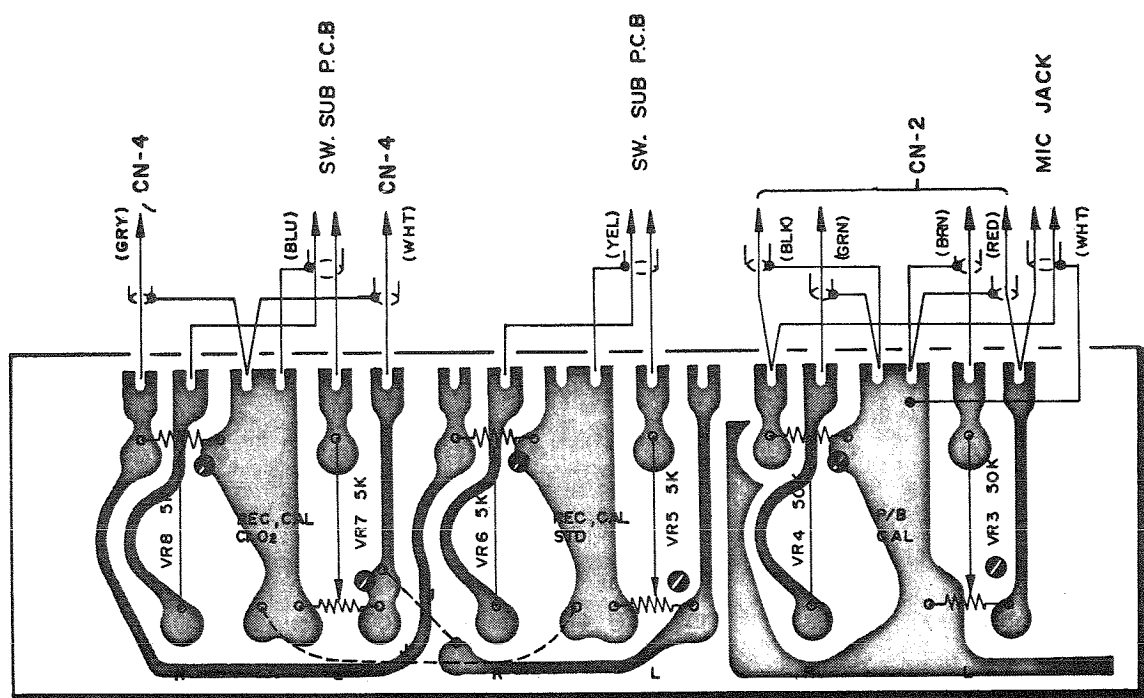

LEVEL ADJUST BOARD

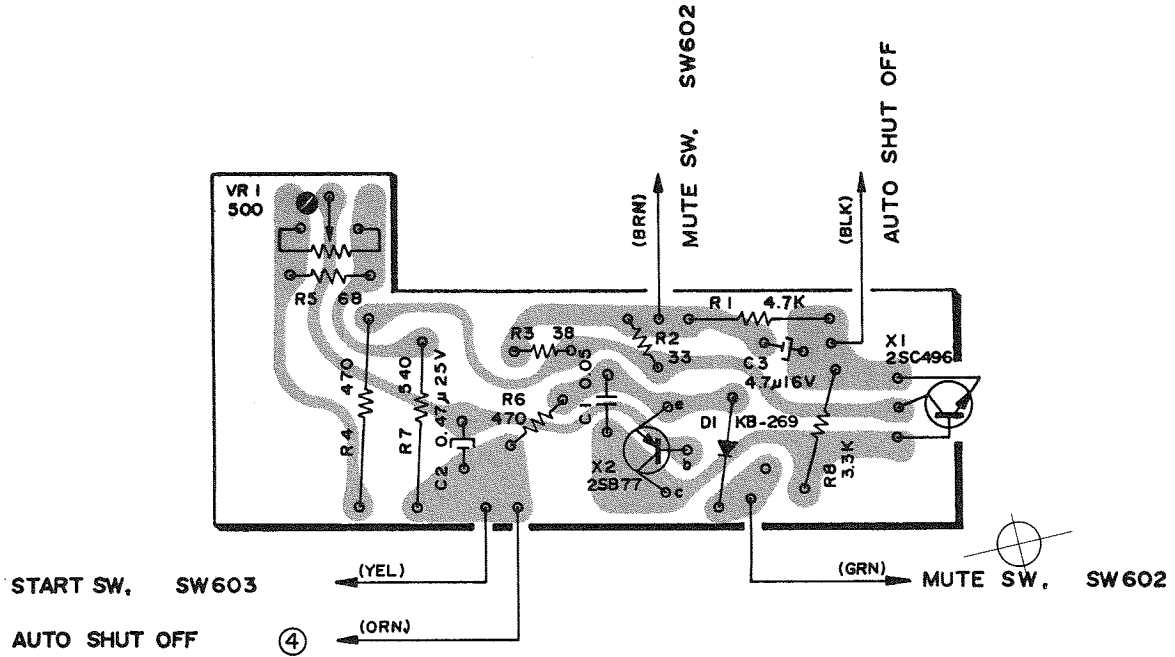

MOTOR GOVERNOR BOARD

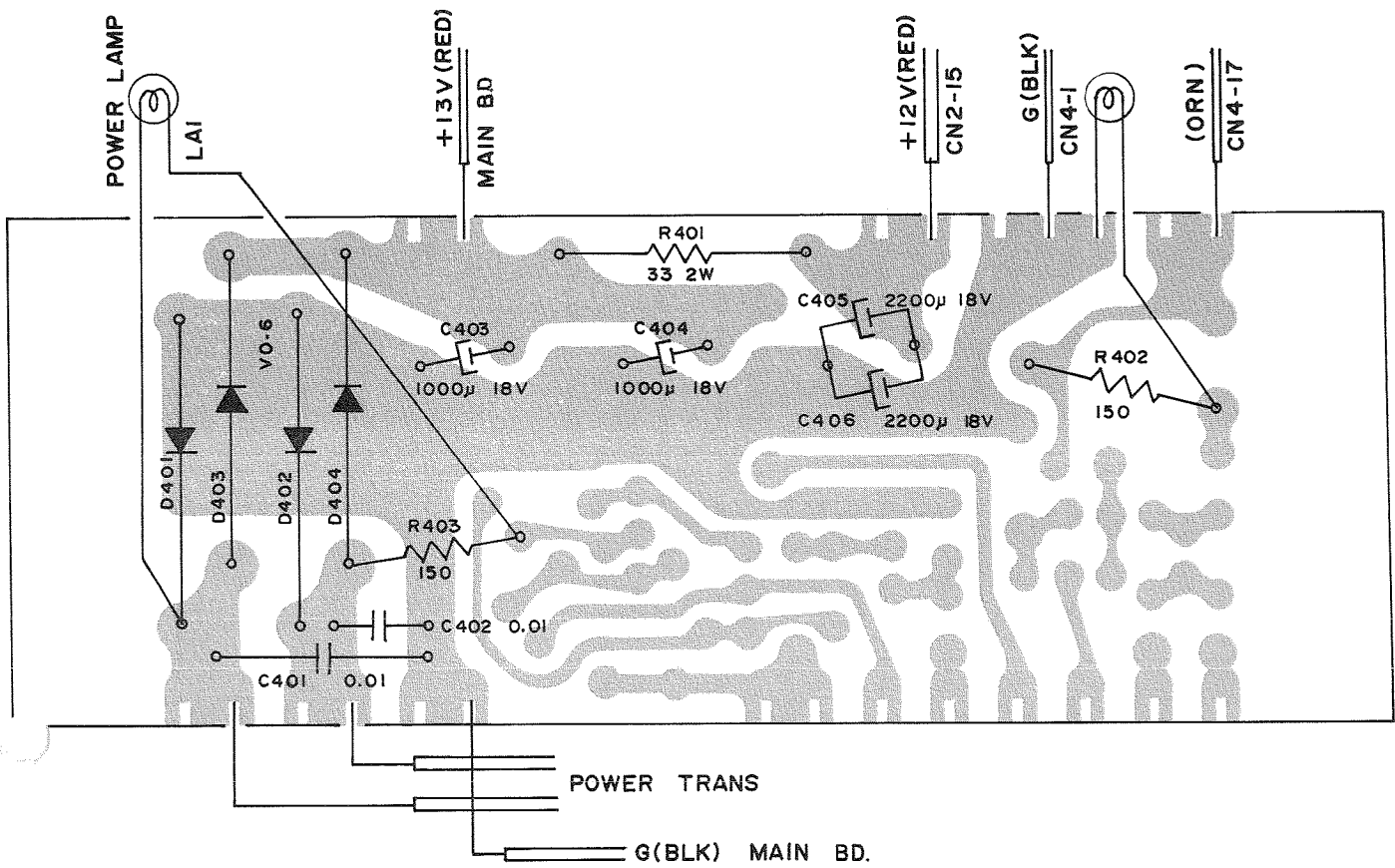

POWER SUPPLY BOARD

CN-1
 MOTOR SERVO P.C.B
 GROUND
 PAUSE SW
 SHUT OFF LAMP
 MOTOR SERVO P.C.B
 START SW
 CN-4

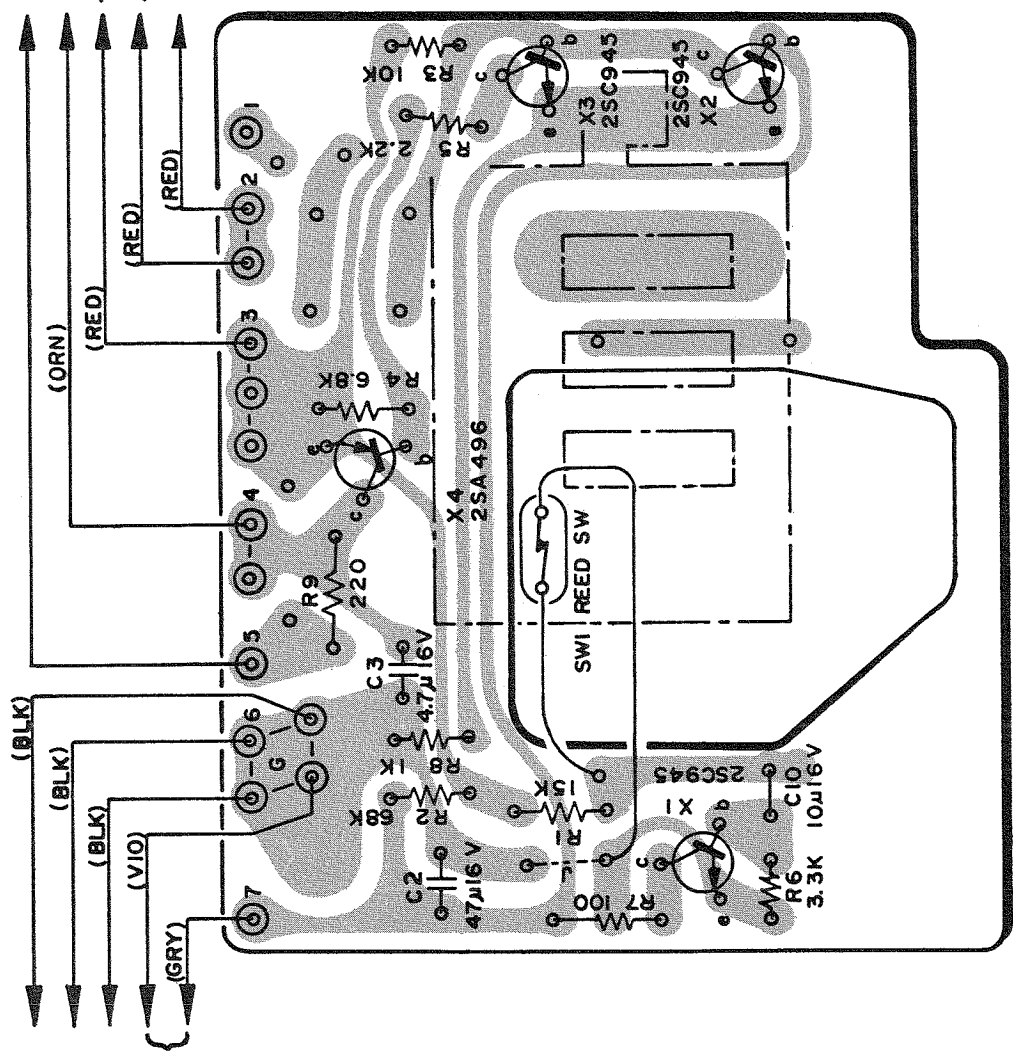

AUTO SHUTOFF BOARD

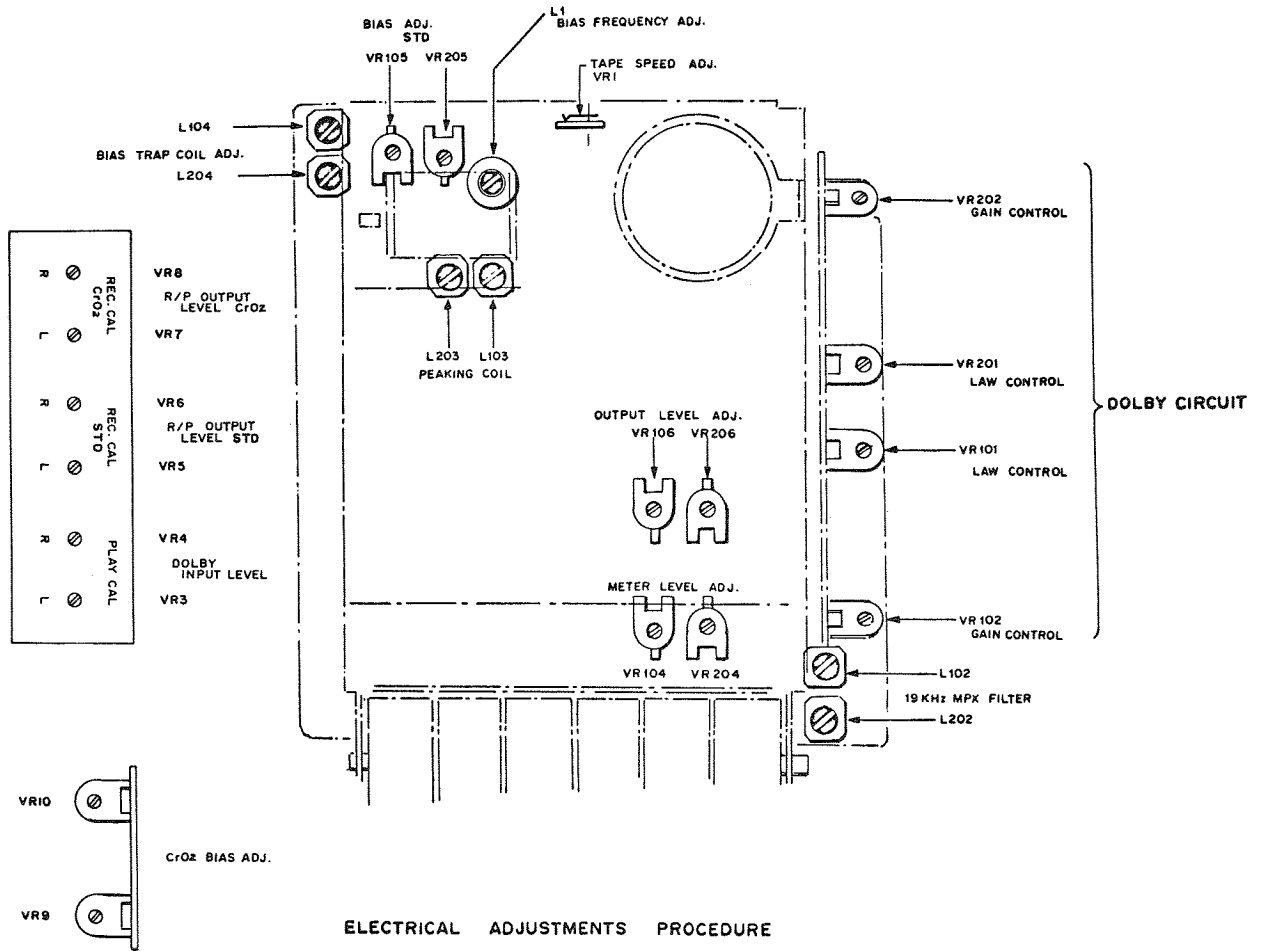

R	⊗	REC:CAL
L	⊗	CROZ
R	⊗	REC:CAL
L	⊗	STD
R	⊗	PLAY CAL
L	⊗	

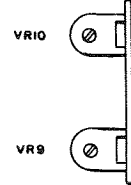

④ CA-3137 HEAD BASE ASSEMBLY

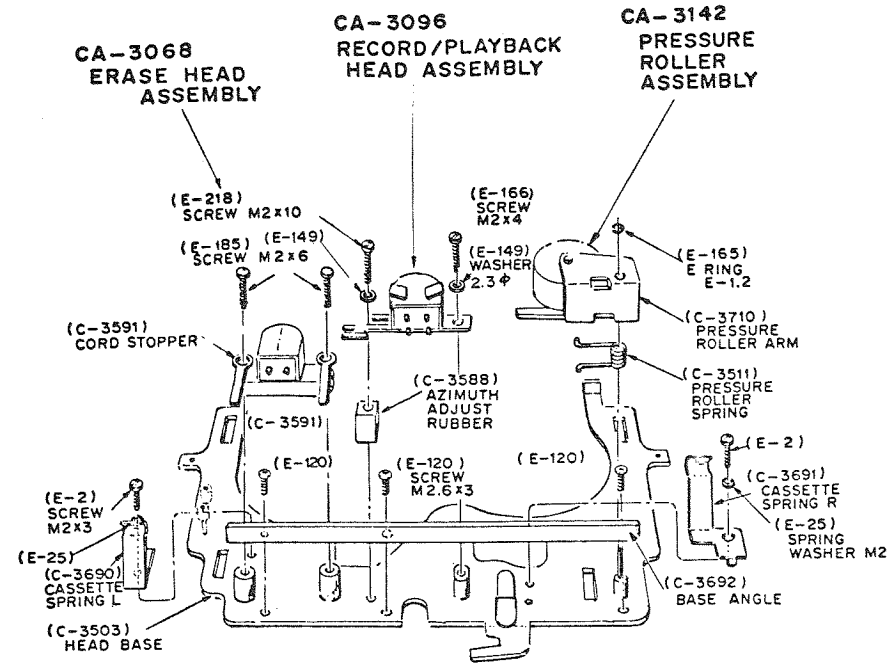

⑨ CA-3161 AUTO SHUT OFF ASS'Y

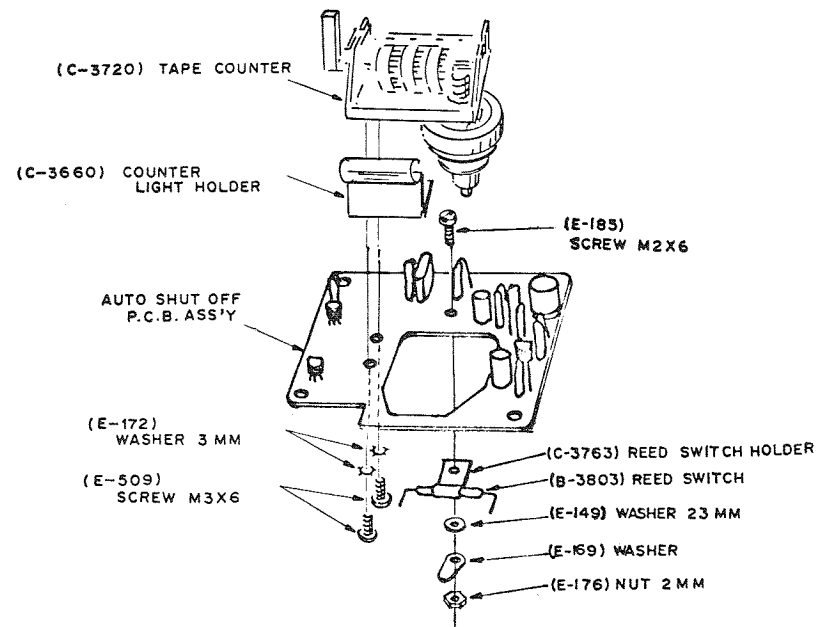

⑥ CA-3139 CASSETTE CASE HOLDER L. ASSEMBLY

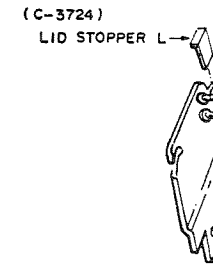

⑤ CA-3138 CASSETTE CASE HOLDER R. ASSEMBLY

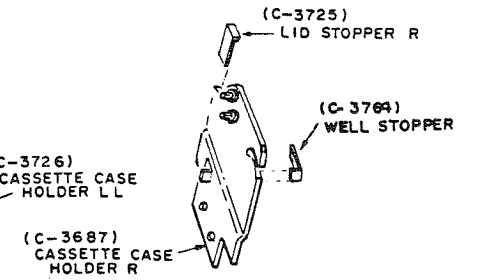

② CA-3140 BRAKE ASSEMBLY

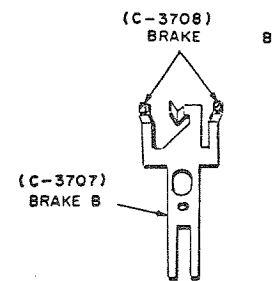

⑧ CA-3149 REEL HUB ASSEMBLY (TAKEUP)

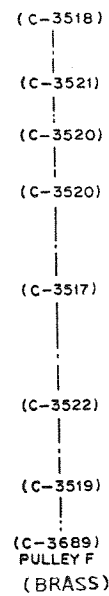

⑦ CA-3103 REEL HUB ASSEMBLY (SUPPLY)

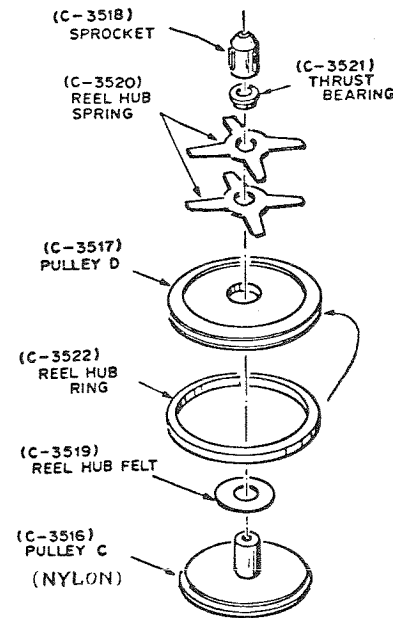

⑬ CA-3165 MOTOR ASSY

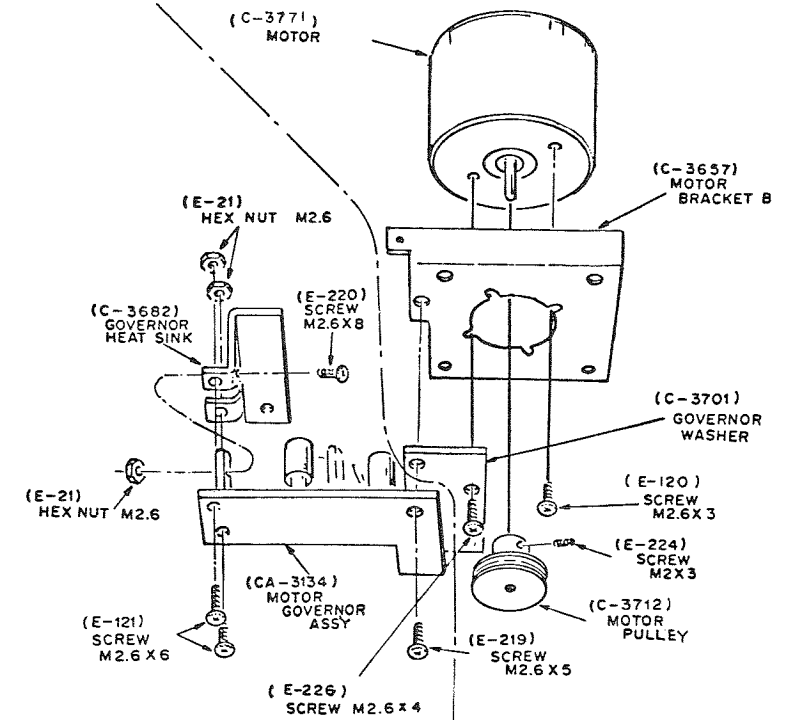

⑰ CA 3166 MOTOR GOVERNOR ASSY

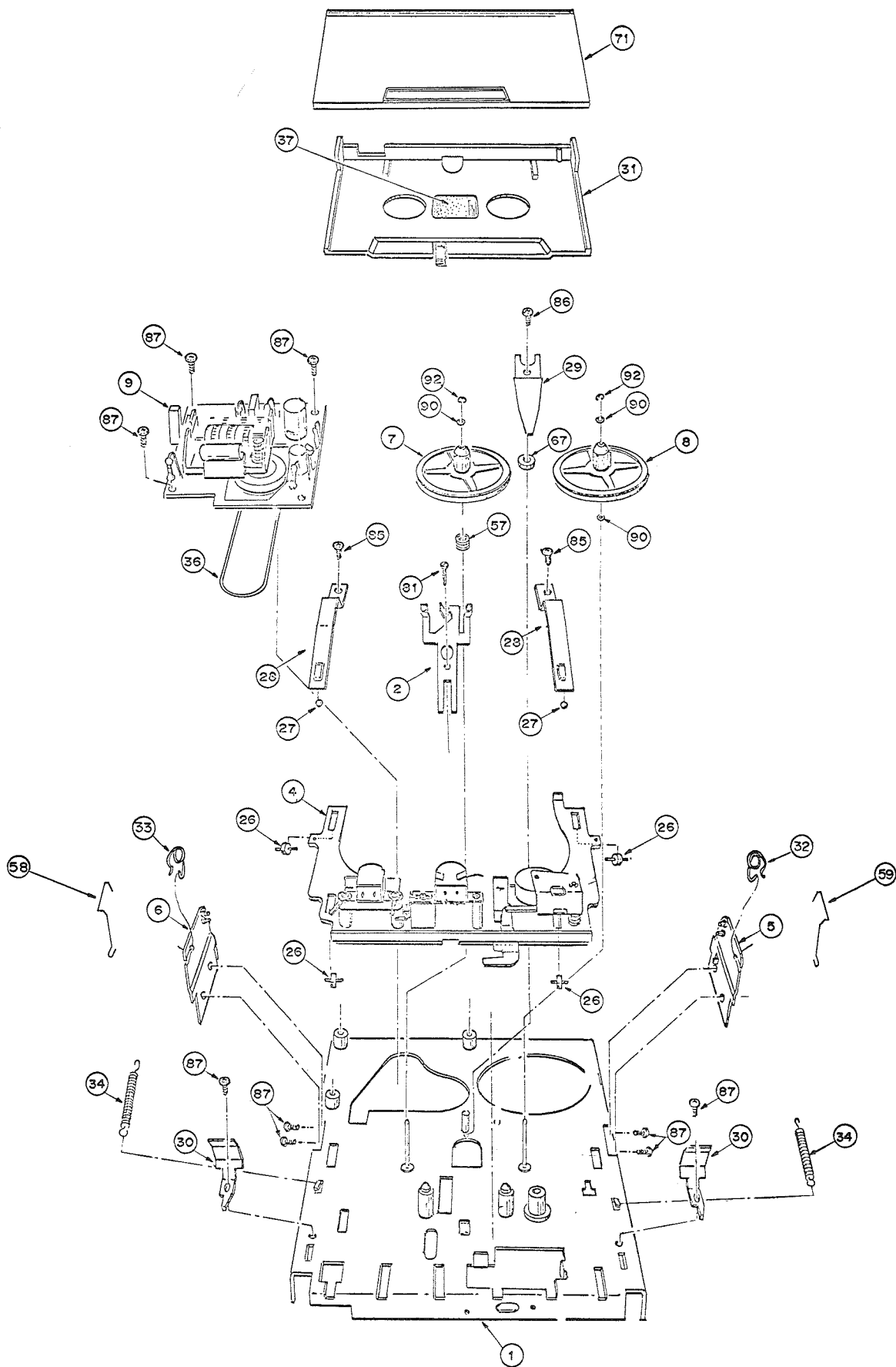

TRANSPORT EXPLODED VIEW, ABOVE DECK

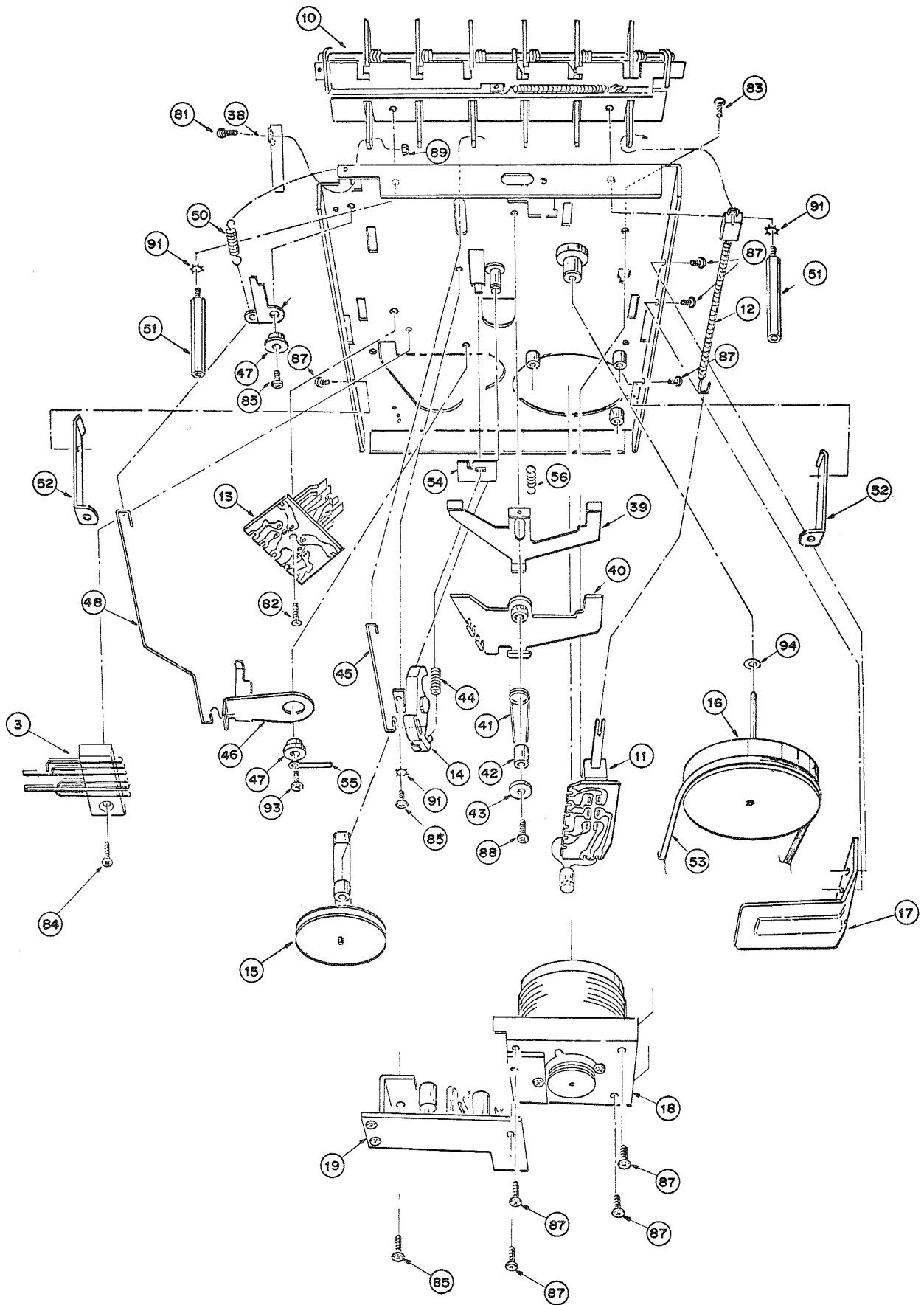

TRANSPORT EXPLODED VIEW, BELOW DECK