

**SERVICE MANUAL**

# FISHER

**RS-1015**

**RS-1020**

**RS-1030**

**Stereo Receivers**

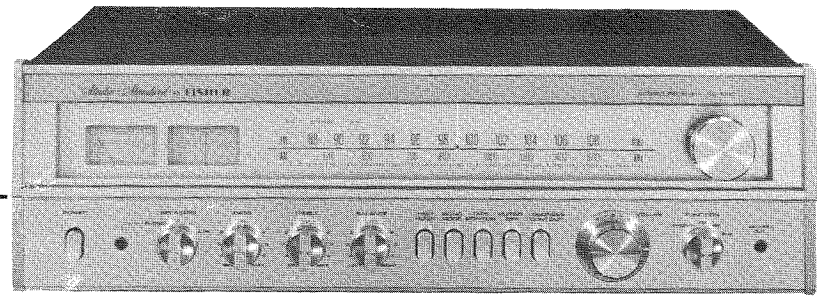

RS-1030

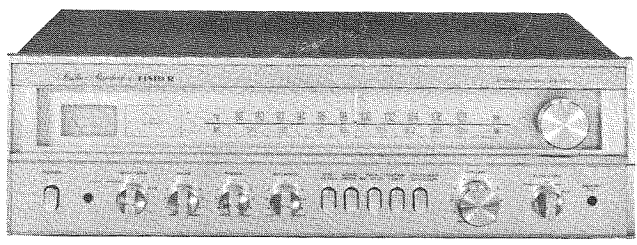

RS-1015

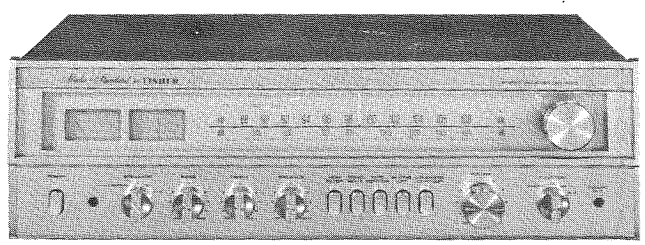

RS-1020

**WORLD LEADER IN HIGH QUALITY STEREO**

## TABLE OF CONTENTS

Disassembly Instructions . . . . .	3
Recommended Test Equipment . . . . .	4
Harmonic Distortion Test . . . . .	4
Specifications . . . . .	5
AM-FM Multiplex Alignment . . . . .	6
Alignment Wave Forms . . . . .	7
AM-FM RF/IF MPX Board Layout . . . . .	7
Dial Cord Stringing . . . . .	8
AM-FM RF/IF MPX P.C. Board . . . . .	9, 10
RF, IF, MPX P.C.B Assy Parts List . . . . .	11
FM IF IC LA1230 Signal Flow . . . . .	12
FM MPX IC LA3350 Signal Flow . . . . .	12
AM RF IF IC HA1151 Signal Flow . . . . .	12
Tone Control and Mode Selector P.C. Board . . . . .	13, 14
Tone P.C.B. Assy Parts List . . . . .	15
EQ P.C. Board . . . . .	16
EQ P.C.B Assy Parts List . . . . .	16
Power Amp P.C. Board . . . . .	17, 18
Power Amp IC Equivalent Circuit . . . . .	17
Power Amp P.C.B Assy Parts List . . . . .	18
Power Supply P.C. Board . . . . .	19
Dial Lamp P.C. Board . . . . .	19
Power Supply P.C.B Assy and Dial Lamp P.C.B Assy Parts List . . . . .	20
Exploded View of Cabinet and Chassis Front Mounted Assemblies (RS-1015) . . . . .	21
(RS-1020) . . . . .	25
(RS-1030) . . . . .	29
Exploded View of Chassis and Rear Mounted Assemblies (RS-1015) . . . . .	22
(RS-1020) . . . . .	26
(RS-1030) . . . . .	30
Schematic Diagram (RS-1015) . . . . .	23, 24
(RS-1020) . . . . .	27, 28
(RS-1030) . . . . .	31, 32
Parts List (RS-1015,RS-1020,RS-1030) . . . . .	33
Misc Parts List (RS-1015, RS-1020, RS-1030) . . . . .	34
Point to Point Wiring Diagram Top View (RS-1015) . . . . .	35, 36
(RS-1020, RS-1030) . . . . .	39, 40
Point to Point Wiring Diagram Bottom View (RS-1015) . . . . .	37, 38
(RS-1020, RS-1030) . . . . .	41, 42

## DISASSEMBLY INSTRUCTIONS

### Removal Of Chassis From Cabinet

1. Remove 4 screws from left and right sides of cabinet.
2. Separate cabinet from chassis.
3. Remove 6 screws from bottom of cabinet. (Do Not Remove Leg From Bottom Of Cabinet).
4. Separate bottom of cabinet from chassis.

### Removal Of Front Panel Assembly

1. Remove all Knobs with the exception of push buttons.
2. Remove 4 screws from top of panel.
3. Remove nut from "Function" and "Speaker" switches located on Front Panel Assembly.
4. Separate Front Panel Assembly from chassis.

### Removal Of Meters

1. Unsolder leads from meter terminals.
2. Remove One screw and Meter Cover.
3. Grasp Meter firmly and pull back separating Meter from panel.

### Removal Of Slide Rail Pointer

1. Remove Metal Slide Pointer from Slide Rail Pointer.
2. Remove 2 screws from top of Slide Rail Pointer.

### Removal Of AM-FM Stereo Function Indicator Lamps

1. Grasp base of lamp with long-nosed Pliers and Carefully extract from grommet holder.
2. Unsolder AM-FM Indicator Lamp from P. C. Board. (RS-1020, RS-1030)

### Removal And Replacement Of Dial Lamps

1. Remove Dial P. C. Board from Shelter Light with two flaps straight.
2. Grasp Dial Lamp and extract from lamp grommet holder.

Testing and troubleshooting any of the P.C. boards do not require removal since all component parts are top board mounted. For underneath board inspection purposes or when a defective component is to be unsoldered and replaced, the P.C. board can be sufficiently turned over by only removing the hold down hardware. Where it necessitates complete removal of any individual board then proceed as follows.

### Removal Of AM-FM RF/IF/MPX Amp P. C. Board

1. Unscrew 2 screws from Drum. (Do Not Remove Dial String From Drum).
2. Remove 6 screws from P. C. Board.
3. Slide P. C. Board from plastic clip.
4. Unsolder connections and remove P. C. Board.

### Removal Of EQ-Amp P. C. Board

1. Unsolder wire wraps from terminals.
2. Remove 4 hold down screws.

### Removal Of Power Supply P. C. Board

1. Unsolder wire wraps from terminals.
2. Remove 5 hold down screws.
3. Slide P. C. Board from plastic clip.

### Removal Of Main Amp P. C. Board

1. Unsolder wire wraps from terminals.
2. Remove 2 screws holding Power IC (PA 501X, RS-1030) (PA 401X, RS-1015, RS-1020)
3. Unscrew and remove plastic clip from P. C. Board.

### Removal Of Tone Control Amp P. C. Board

1. Unsolder wire wraps from terminals.
2. Remove 2 screws from left and right sides of 4 push button switch.
3. Remove 4 nuts from variable resistors.
4. Unscrew and remove 2 plastic clips from P. C. Board.

## RECOMMENDED TEST EQUIPMENT

The following test equipment is recommended to completely test and align the Receiver:

- Line Voltage Isolation Transformer.
- AC DC Multimeter.
- Accurately Calibrated AC Voltmeter.
- Oscilloscope (Flat to 100 kHz Minimum)
- Low-Distortion Audio Sine-Wave Generator
- Harmonic Distortion Analyzer
- Two (2) Load Resistors, 8-ohms, 250 Watts (Minimum Rating)
- Low-Distortion AM-FM Signal Generator
- 10.7 MHz Sweep Generator
- Multiplex Generator
- 455 kHz Sweep Generator

## HARMONIC DISTORTION TEST

CAUTION: Limit the following tests to no more than ten minutes each. Use 8-ohm resistors with a minimum power rating of 250 watts when connecting a load across the SPEAKERS terminals.

### CONTROL SETTINGS:

Unplug the AC power cord and set the front panel controls as follows:

BASS, TREBLE, and BALANCE controls to center positions

POWER push button out (not depressed)

SPEAKERS switch to PHONES

FUNCTION switch to AUX

HIGH FILTER, MONO MODE, TAPE MONITOR and LOUDNESS CONTOUR out (not depressed)

VOLUME control to MINIMUM position

LEFT CHANNEL DRIVEN

### ONE CHANNEL DRIVEN:

- 1) Connect a low distortion audio generator to LEFT AUX IN jack. Set generator frequency to 1 kHz and output to minimum.
- 2) Connect an 8-ohm load resistor between SPEAKERS MAIN LEFT and COM terminals. Connect a Harmonic Distortion analyzer and an AC VTVM in parallel across the 8-ohm load.
- 3) Connect the AC power cord and set SPEAKERS switch to MAIN. Turn VOLUME control to MAX.
- 4) Increase generator output for  
RS-1015 15W RMS (11.0V across the 8ohm load)  
RS-1020 20W RMS (12.6V across the 8ohm load)  
RS-1030 30W RMS (15.5V across the 8ohm load)  
Harmonic Distortion Analyzer should measure 0.8% (RS-1015), 0.5%(RS-1020, RS-1030) distortion or less.
- 5) Repeat steps 1 through 4 for RIGHT CHANNEL.

## BOTH CHANNELS DRIVEN

Connect 8-ohm load resistors across LEFT and RIGHT MAIN SPEAKERS terminals. Depress "MONO MODE" pushbutton. Adjust generator output and "BALANCE" control for RS-1015:15W/RS-1020:20W/RS-1030:30W at Left and Right Channels (RS-1015:11.0V/RS-1020:12.6V/RS-1030:15.5V) across the 8-ohm loads. Harmonic Distortion Analyzer should measure RS-1015:0.8%/RS-1020, RS-1030:0.5% distortion or less at each channel.

**Nominal Specifications For Information Only.  
Do Not Use For Servicing**

RECEIVERS		RS-1015	RS-1020	RS-1030
<b>POWER AMPLIFIER SECTION</b> Continuous RMS sine wave power per channel within stated bandwidth at no more than stated distortion and with an 8 ohm load.				
Power Bandwidth		20Hz/20kHz	20Hz/20kHz	20Hz/20kHz
Total Harmonic Distortion		0.8 %	0.5 %	0.5 %
<b>PREAMPLIFIER SECTION</b> Input Sensitivity and Impedance At rated output, 8-ohms at 1kHz Phono				
Phono (max input capability)		2mV/ 50k Ω	2mV/ 50k Ω	2mV/ 50k Ω
Auxiliary		150mV/100k Ω	150mV/100k Ω	150mV/100k Ω
Tape Monitor (1 and 2)		150mV/100k Ω	150mV/100k Ω	150mV/100k Ω
Hum & Noise (below rated output) Phono		60 dB	60 dB	60 dB
Auxiliary		70 dB	70 dB	70 dB
Tape Monitor (1 and 2)		70 dB	70 dB	70 dB
Frequency Response Phono (RIAA EQUALIZED ±2dB)		30Hz - 15kHz	30Hz - 15kHz	30Hz - 15kHz
Auxiliary input ±2 dB		20Hz - 20kHz	20Hz - 20kHz	20Hz - 20kHz
Tape Monitor input ±2 dB		20Hz - 20kHz	20Hz - 20kHz	20Hz - 20kHz
Bass Control Range (at 100Hz)		±10 dB	±10 dB	±10 dB
Treble Control Range (at 10kHz)		±10 dB	±10 dB	±10 dB
Loudness Contour (at 30dB volume attenuation)		+8dB at 100Hz +4dB at 10kHz	+8dB at 100Hz +4dB at 10kHz	+8dB at 100Hz +4dB at 10kHz
High Filter		-6dB (5kHz)	-6dB (5kHz)	-6dB (5kHz)
Separation (Stereo) @ 1kHz		40 dB	40 dB	40 dB
<b>POWER SECTION INPUT</b>		—	—	150mV/ 50k Ω
<b>FM TUNER SECTION</b>				
Usable Sensitivity		Mono 2 μV/11.2 dBf Stereo 4.8 μV/18.9 dBf	Mono 2 μV/11.2 dBf Stereo 4.8 μV/18.9 dBf	Mono 2 μV/11.2 dBf Stereo 4.8 μV/18.9 dBf
50dB Quieting Sensitivity		Mono 2.8 μV/14.2 dBf Stereo 38 μV/ 36.8 dBf	Mono 2.8 μV/14.2 dBf Stereo 38 μV/ 36.8 dBf	Mono 2.8 μV/14.2 dBf Stereo 38 μV/ 36.8 dBf
Capture Ratio		1.2 dB	1.2 dB	1.2 dB
Alt Channel Selectivity		65 dB	65 dB	65 dB
Image Response Rejection		56 dB	56 dB	56 dB
Spurious Response Rejection		85 dB	85 dB	85 dB
AM Rejection		55 dB	55 dB	55 dB
Signal-to-Noise Ratio (Mono & Stereo)		68.66 dB	68.66 dB	68.66 dB
Total Harm. Distortion (Mono & Stereo)		0.3/0.4%	0.3/0.4%	0.3/0.4%
50dB Quieting Sensitivity THD		Mono 0.4 % Stereo 0.5 %	Mono 0.4 % Stereo 0.5 %	Mono 0.4 % Stereo 0.5 %
Stereo Separation (1 kHz/10 kHz)		40/30 dB	40/30 dB	40/30 dB
Sub-Carrier Suppression (19/38kHz)		60/70 dB	60/70 dB	60/70 dB
<b>AM TUNER SECTION</b>				
Sensitivity		300 μV/m	300 μV/m	300 μV/m
Selectivity		40 dB	40 dB	40 dB
Signal-to-Noise Ratio		55 dB	55 dB	55 dB
Image Frequency Rejection		50 dB	50 dB	50 dB
IF Rejection		45 dB	45 dB	45 dB
<b>GENERAL</b>		120V AC ±10 %	120V AC ±10 %	120V AC ±10 %
Power Requirements (50/60 Hz)		160W/180VA	210W/240VA	300W/340VA
AC Outlets		2	2	2
Dimensions H x W x D		Inches 6-1/16"x19-1/8"x 13-1/8"	Inches 6-1/16"x19-1/8"x 13-1/8"	Inches 6-1/16"x19-1/8"x 13-1/8"
Weight (Lbs.)		21.6	23	24.3

# AM-FM MULTIPLEX ALIGNMENT

## AM ALIGNMENT

Step	Adjusting circuit	Connection		SG. frequency	Position of tuning dial	Adjustment	V.T.V.M. Oscilloscope
		Input	Output				
1	IF	Connect sweep generator to VC4.	Connect oscilloscope to test point TP 19	455 KHz	Near max. capacity of VC at position with no signal.	AM 1st 9-21310 AM DET 9-21291	 455 KHz
2	RF	Connect standard loop antenna to output terminal of SG. Place receiver 2 feet from loop antenna	Connect V.T.V.M. to TP 19	600 KHz (400Hz, 30 % modulation)	600 KHz	AM ANT 9-21172 AM OSC 9-20851	Max.
3				1400 KHz (400Hz, 30 % modulation)	1400 KHz	TC4 TC5	Max.
4	Repeat adjustments.						

- Variable capacitor completely closed.
- Set the dial pointer to very left line dial scale.
- Connect sweep generator, SG, V.T.V.M. and oscilloscope.
- Function switch to "AM."
- Use a screwdriver with plastic grip for all adjustments.

## FM ALIGNMENT

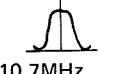
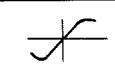
Step	Adjusting circuit	Connection		SG. frequency	Position of tuning dial	Adjustment	V.T.V.M. Oscilloscope
		Input	Output				
1	IF	Connect sweep generator to test point TP 5 through 0.01 μF.	Connect oscilloscope to test point TP 7	10.7 MHz (none modulation)	Near max. capacity of VC. at position with no signal.	IFT In FRONT END	 10.7MHz
2	Ratio Det.		Connect oscilloscope to test point TP 6			FM QUADRA TURE COIL. 9-21320	
3	RF	Connect FM SG. to FM ANT terminals.	Connect V.T.V.M. to speaker terminal.	90 MHz (400 Hz, 30 % modulation)	90 MHz	LA LR	Max.
4				106 MHz (400 Hz, 30 % modulation)	106 MHz	TCA TCR	Max.
5	Repeat adjustments.						

- Variable capacitor completely closed.
- Set the dial pointer to very left line of dial scale.
- Connect sweep generator, FM SG, V.T.V.M. and oscilloscope. FM ANT input impedance is 300 ohm.
- Function switch to "FM."
- Use a screwdriver with plastic grip for all adjustments.

## FM MPX ALIGNMENT

Step	Adjusting circuit	Connection		Position of tuning dial	Adjustment	
		Input	Output			
1	PLL IC FO (19 KHz) Adjustment	None	Connect Frequency counter or synchroscope to TP 8		Adjust VR 01 (5K-B) so that 19 KHz may be indicated on the frequency counter or synchroscope.	
2	FM STEREO Signal Separation	Connect FM stereo SG to FM ANT terminals. 19 KHz signal ON. Main channel, sub channel signal ON. Add 1000 Hz signal from L Ch.	Connect V.T.V.M. to output terminal (R channel).	Near max. capacity of VC. at position with no signal.	VR 02 (1K-B)	V.T.V.M. Min.
		Connect FM stereo SG to FM ANT terminals. 19 KHz signal ON. Main channel, sub channel signal ON. Add 1000 Hz signal from R Ch.	Connect V.T.V.M. to output terminal (L channel)			
3	Repeat steps 1, 2, Set at position with max. channel separation.					

- Variable capacitor completely closed.
- Connect FM stereo SG and V.T.V.M.
- Function switch to "FM"
- Use a screwdriver with plastic grip for all adjustments.

# ALIGNMENT WAVE FORMS

WITH OSCILLOSCOPE TIME BASE SETTINGS

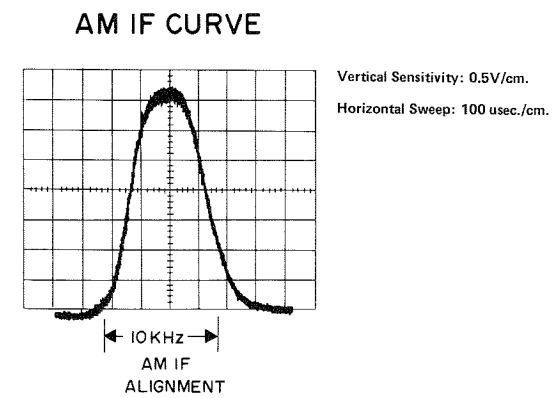
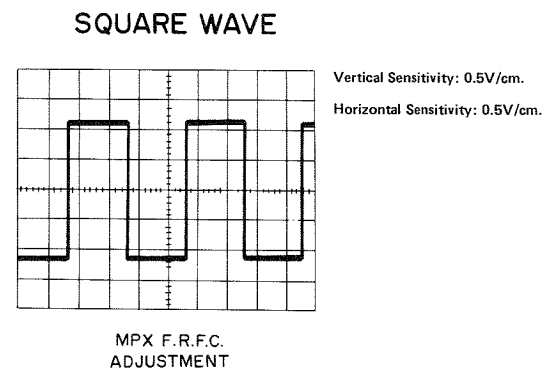
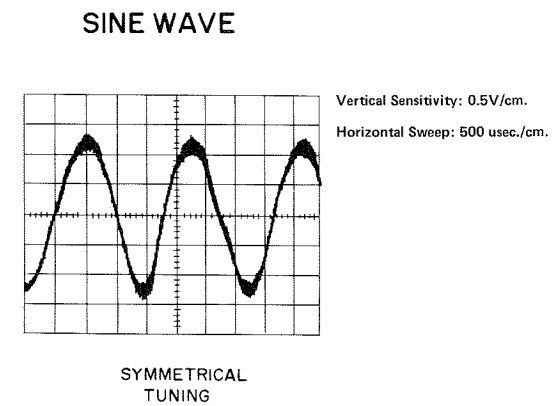
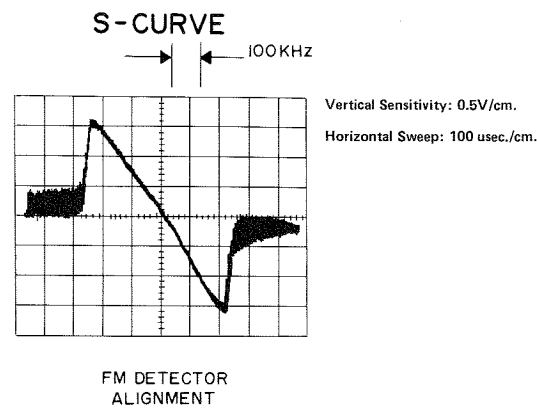
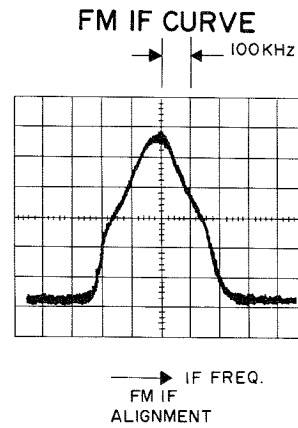

## AM-FM RF/IF MPX BOARD LAYOUT

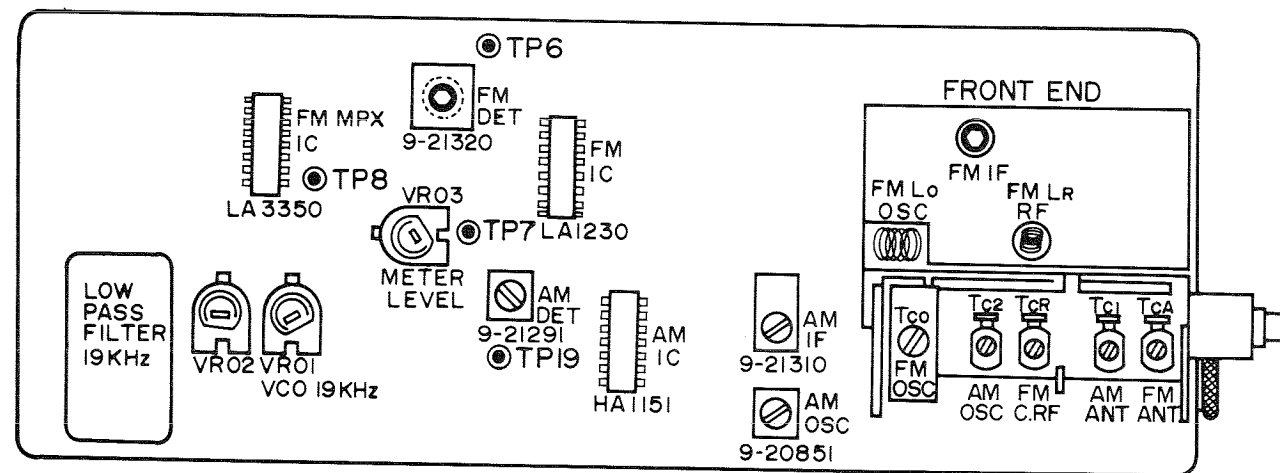
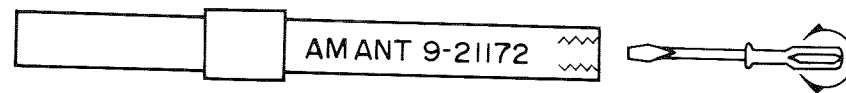

## DIAL CORD STRINGING

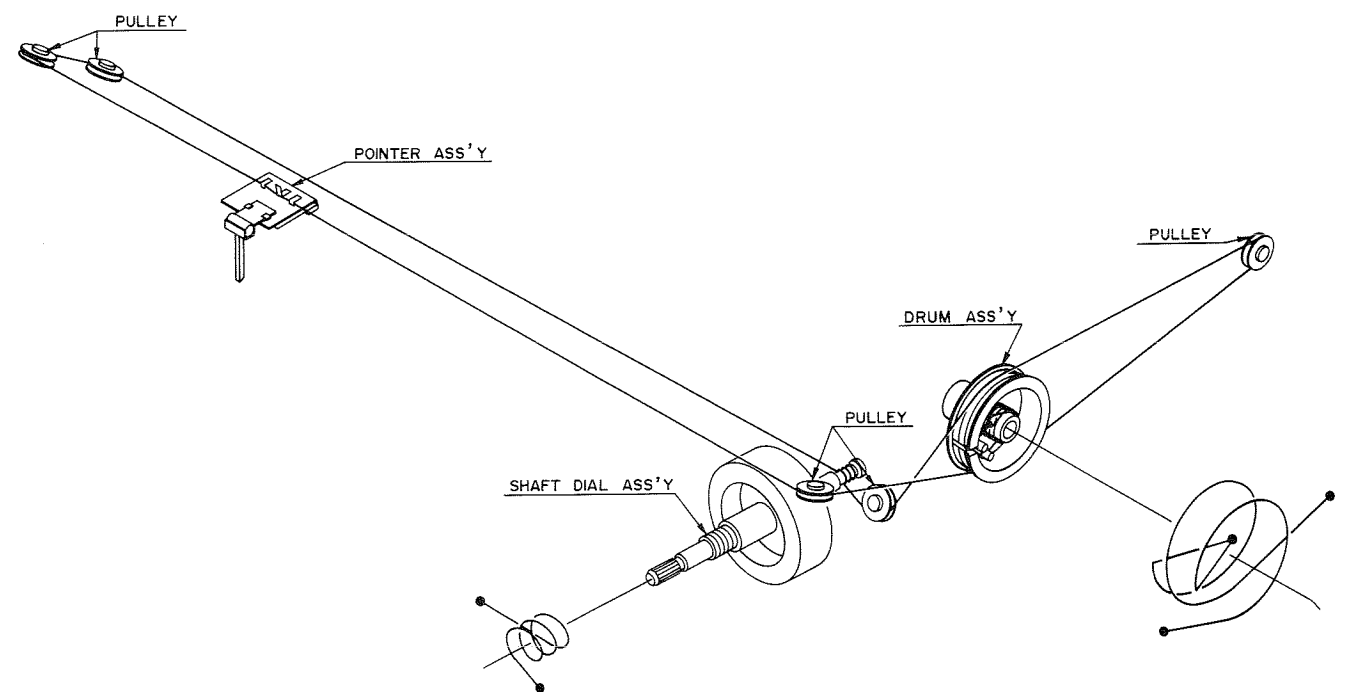

# AM-FM RF/IF MPX P.C.BOARD

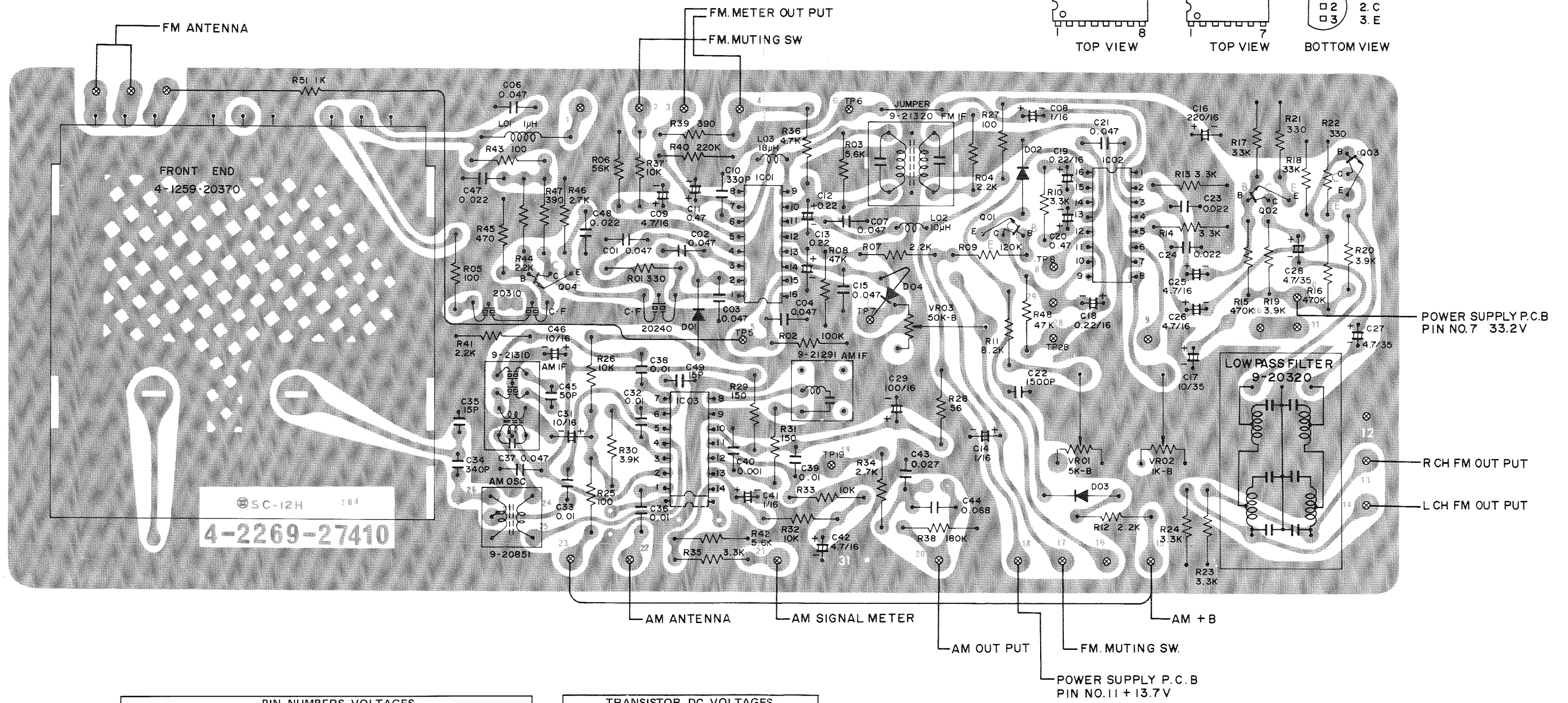
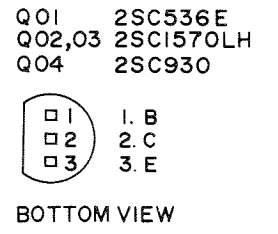
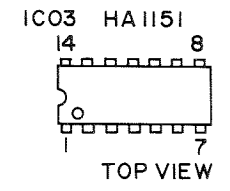
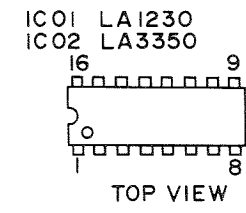

IC	PIN NUMBERS VOLTAGES															
	1	2	3	4	5	6	7	8	9	10	11	12	13	14	15	16
IC01 LA1230	2.9	2.9	2.9	0	1.9	5.5	5.5	5.5	5.5	5.5	13.8	3	0.01	0	5.1	0
IC02 LA3350	12.6	2.7	4.8	10.5	10.4	13.4	0	0.4		0.6	2	2.4	1.9	2	2	2.7
IC03 HA1151	0.97	12.7	10.9	12.7	3.5	1.24	2.1	8.5	0	13.3	1.6	0.7	1.4	0		

TRANSISTOR DC VOLTAGES				
SYMBOL No.	DEVICE	B	C	E
Q01	2SC536E	1.1	0.6	0.5
Q02	2SC1570LH	2	16.5	1.4
Q03	2SC1570LH	2	16.5	1.4
Q04	2SC930D	2.2	12.8	1.6

## BOTTOM VIEW

# PARTS LIST

RF. IF. MPX. PCB Assy  
1310 4001 72110

Symbol NO.	Part Number	Description
79-1	4 1259 20370	Front End
VR01	01 51283	VR 5K (19KHz)
VR02	01 51282	VR 1K (Separation)
VR03	4 2229 25400	VR 50K Meter Level
	4 2279 20240	Ceramic Filter
	4 2279 20310	Ceramic Filter
	4 2279 20320	Low Pass Filter 19KHz
	4 2569 21291	IF Trans AM
	4 2569 21310	IF Trans AM
	4 2569 21320	IF Trans FM

L01	4 2589 20851	OSC Coil AM
L02	4 2539 20120	IF Trap 1 $\mu$ H
L03	4 2539 20370	10 $\mu$ H $\pm$ 10%
	4 2539 20380	18 $\mu$ H $\pm$ 5%

## CAPACITORS

C01, 02	CK22348-1	Ceramic 0.047 $\mu$ F 50V
	03, 04	
	06, 07	
C08	CS22340-5	Sint. Alu. 1 $\mu$ F 16V
C09	CE1252515	Electrolytic 4.7 $\mu$ F 16V $\pm$ 10%
C10	CK22347-7	Ceramic 330pF 50V $\pm$ 10%
C11	CS22340-4	Sint. Alu. 0.47 $\mu$ F 16V +40% -20%
C12, 13	CS22340-2	Sint. Alu. 0.22 $\mu$ F 16V +40% -20%
C14	CE0252611	Electrolytic 1 $\mu$ F 16V
C15	CK22348-1	Ceramic 0.047 $\mu$ F 50V +80% -20%
C16	CE22342-15	Electrolytic 220 $\mu$ F 16V
C17	CE22342-28	Electrolytic 10 $\mu$ F 35V
C18, 19	CS22340-2	Sint. Alu. 0.22 $\mu$ F 16V +40% -20%
C20	CS22340-4	Sint. Alu. 0.47 $\mu$ F 16V +40% -20%
C21	CY22335-22	Mylar 0.047 $\mu$ F 50V $\pm$ 20%
C22	0217823	Styrol 1500pF 35V $\pm$ 5%
C23, 24	CIHFRK223A	Mylar 0.022 $\mu$ F 50V $\pm$ 10%
C25, 26	CS22340-6	Sint. Alu. 4.7 $\mu$ F 16V +40% -20%
C27, 28	CL22305-14	Tantal 4.7 $\mu$ F 35V $\pm$ 20%
C29	CE22342-11	Electrolytic 100 $\mu$ F 16V
C31	CE1252521	Electrolytic 10 $\mu$ F 16V
C32, 33	CY22335-1	Mylar 0.01 $\mu$ F 50V $\pm$ 20%
C34	CIHSEJ341A	Styrol 340pF 50V $\pm$ 5%
C35	CK22344-9	Ceramic 15pF 50V $\pm$ 5%
C36	CY22335-1	Mylar 0.01 $\mu$ F 50V $\pm$ 20%
C37	CK22348-1	Ceramic 0.047 $\mu$ F 50V +80% -20%
C38, 39	CY22335-1	Mylar 0.01 $\mu$ F 50V $\pm$ 20%
C40	CY22335-3	Mylar 0.001 $\mu$ F 50V $\pm$ 20%
C41	CS22340-5	Sint. Alu. 1 $\mu$ F 16V +40% -20%
C42	CE1252515	Electrolytic 4.7 $\mu$ F 16V
C43	CIHFRM273A	Mylar 0.027 $\mu$ F 50V $\pm$ 20%
C44	CY22335-16	Mylar 0.068 $\mu$ F 50V $\pm$ 20%
C45	CK0242011	Ceramic 50pF 50V $\pm$ 10%
C46	CE1252521	Electrolytic 10 $\mu$ F 16V
C47, 48	CK22347-15	Ceramic 0.022 $\mu$ F 50V +80% -20%
C49	CK22344-9	Ceramic 15pF 50V $\pm$ 5%

Symbol No.	Part Number	Description
<b>SEMICONDUCTORS</b>		
D01, 02	TRDS442	DS-442
	03, 04	
IC01	TRLA1230	LA1230
IC02	TRLA3350	LA3350
IC03	TRHA1151	HA1151
Q01	TR2SC536E	2SC536E
Q02, 03	TR2SC1570LG	2SC1570 LH
Q04	TR2SC930D	2SC930D

## RESISTORS

R01	RF25DC331J	Carbon	330	1/4W	$\pm$ 5%
R02	RF25DC104J	Carbon	100K	1/4W	$\pm$ 5%
R03	RF25DC562J	Carbon	5.6K	1/4W	$\pm$ 5%
R04	RF25DC222J	Carbon	2.2K	1/4W	$\pm$ 5%
R05	RF25DC101J	Carbon	100	1/4W	$\pm$ 5%
R06	RF25DC563J	Carbon	56K	1/4W	$\pm$ 5%
R07	RF25DC222J	Carbon	2.2K	1/4W	$\pm$ 5%
R08	RF25DC473J	Carbon	47K	1/4W	$\pm$ 5%
R09	RF25DC124J	Carbon	120K	1/4W	$\pm$ 5%
R10	RF25DC332J	Carbon	3.3K	1/4W	$\pm$ 5%
R11	RF25DC822J	Carbon	8.2K	1/4W	$\pm$ 5%
R12	RF25DC222J	Carbon	2.2K	1/4W	$\pm$ 5%
R13, 14	RF25DC332J	Carbon	3.3K	1/4W	$\pm$ 5%
R15, 16	RF25DC474J	Carbon	470K	1/4W	$\pm$ 5%
R17, 18	RF25DC333J	Carbon	33K	1/4W	$\pm$ 5%
R19, 20	RF25DC392J	Carbon	3.9K	1/4W	$\pm$ 5%
R21, 22	RF25DC331J	Carbon	330	1/4W	$\pm$ 5%
R23, 24	RF25DC332J	Carbon	3.3K	1/4W	$\pm$ 5%
R25	RF25DC101J	Carbon	100	1/4W	$\pm$ 5%
R26	RF25DC103J	Carbon	10K	1/4W	$\pm$ 5%
R27	RF25DC101J	Carbon	100	1/4W	$\pm$ 5%
R28	RF25DC560J	Carbon	56	1/4W	$\pm$ 5%
R29	RF25DC151J	Carbon	150	1/4W	$\pm$ 5%
R30	RF25DC392J	Carbon	3.9K	1/4W	$\pm$ 5%
R31	RF25DC151J	Carbon	150	1/4W	$\pm$ 5%
R32, 33	RF25DC103J	Carbon	10K	1/4W	$\pm$ 5%
R34	RF25DC272J	Carbon	2.7K	1/4W	$\pm$ 5%
R35	RF25DC332J	Carbon	3.3K	1/4W	$\pm$ 5%
R36	RF25DC472J	Carbon	4.7K	1/4W	$\pm$ 5%
R37	RF25DC103J	Carbon	10K	1/4W	$\pm$ 5%
R38	RF25DC184J	Carbon	180K	1/4W	$\pm$ 5%
R39	RF25DC391J	Carbon	390	1/4W	$\pm$ 5%
R40	RF25DC224J	Carbon	220K	1/4W	$\pm$ 5%
R41	RF25DC222J	Carbon	2.2K	1/4W	$\pm$ 5%
R42	RF25DC562J	Carbon	5.6K	1/4W	$\pm$ 5%
R43	RF25DC101J	Carbon	100	1/4W	$\pm$ 5%
R44	RF25DC222J	Carbon	2.2K	1/4W	$\pm$ 5%
R45	RF25DC471J	Carbon	470	1/4W	$\pm$ 5%
R46	RF25DC272J	Carbon	2.7K	1/4W	$\pm$ 5%
R47	RF25DC391J	Carbon	390	1/4W	$\pm$ 5%
R48	RF25DC473J	Carbon	47K	1/4W	$\pm$ 5%
R51	RF25DC102J	Carbon	1K	1/4W	$\pm$ 5%

## FM IF IC LA1230 SIGNAL FLOW

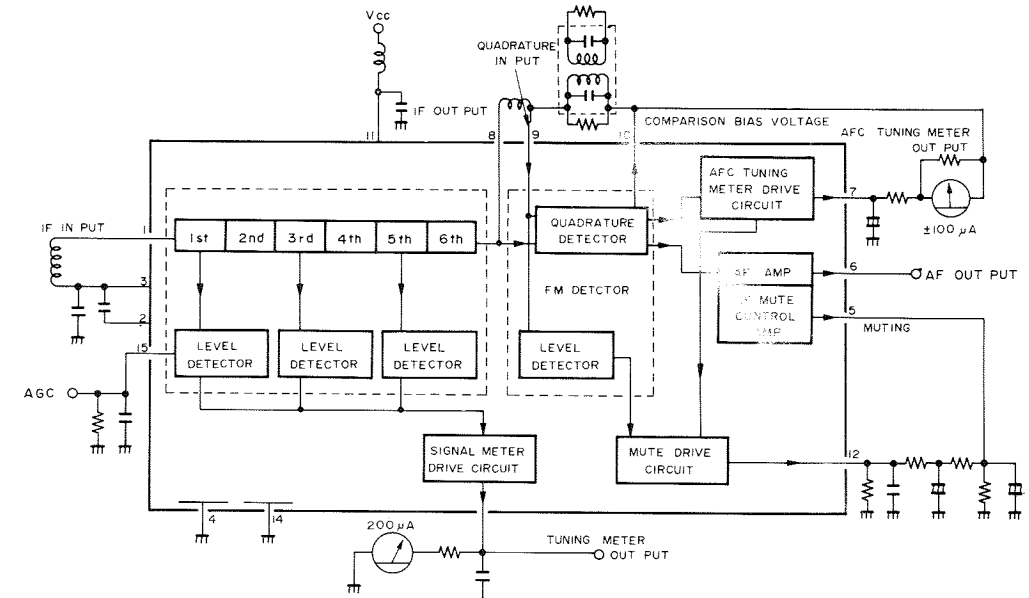

## FM MPX IC LA3350 SIGNAL FLOW

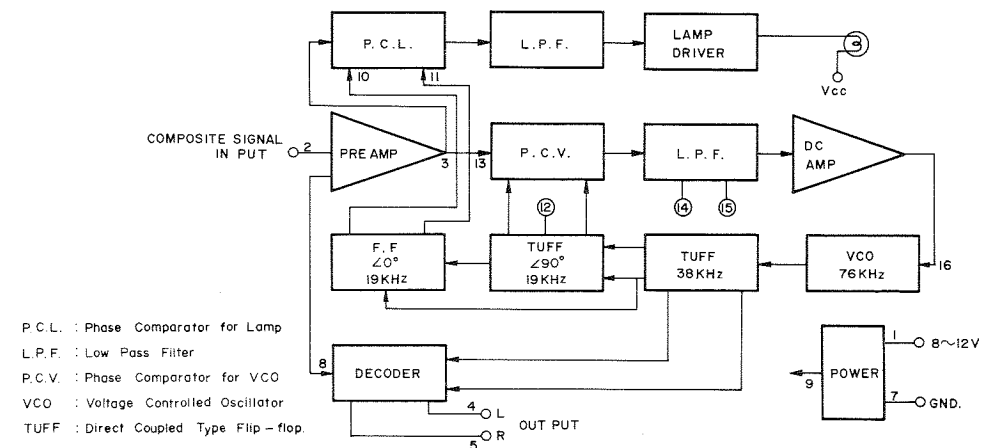

## AM RF IF IC HA1151 SIGNAL FLOW

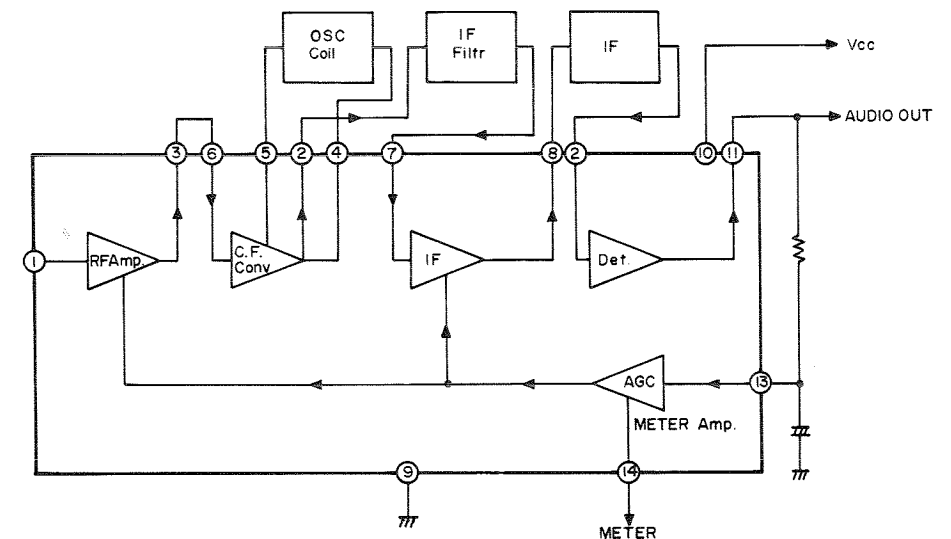

# TONE CONTROL AND MODE SELECTOR P.C.BOARD

RS-1015  
RS-1020

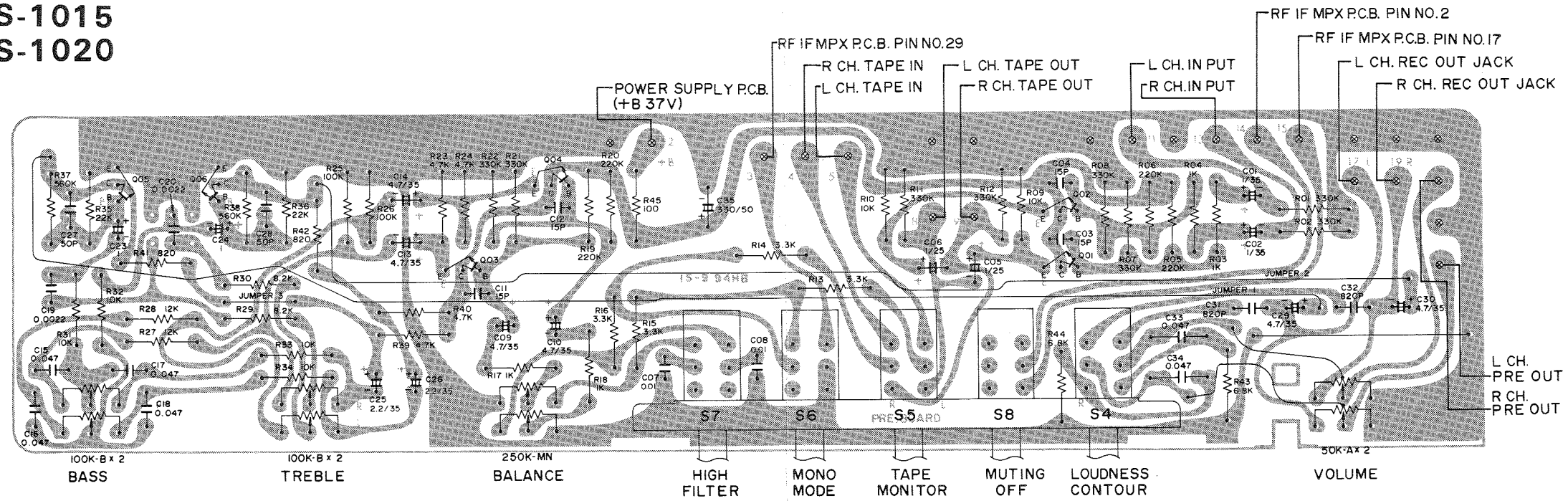

TRANSISTOR DC VOLTAGES				
SYMBOL No.	DEVICE	B	C	E
Q01, 02	2SC1570LH	20.3	35.1	20
Q03, 04	2SC1570LH	20	35.1	19.4
Q05, 06	2SC1570LH	0.6	18.8	0

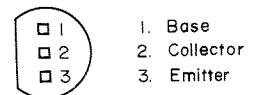

TRANSISTOR BOTTOM VIEW

RS-1030

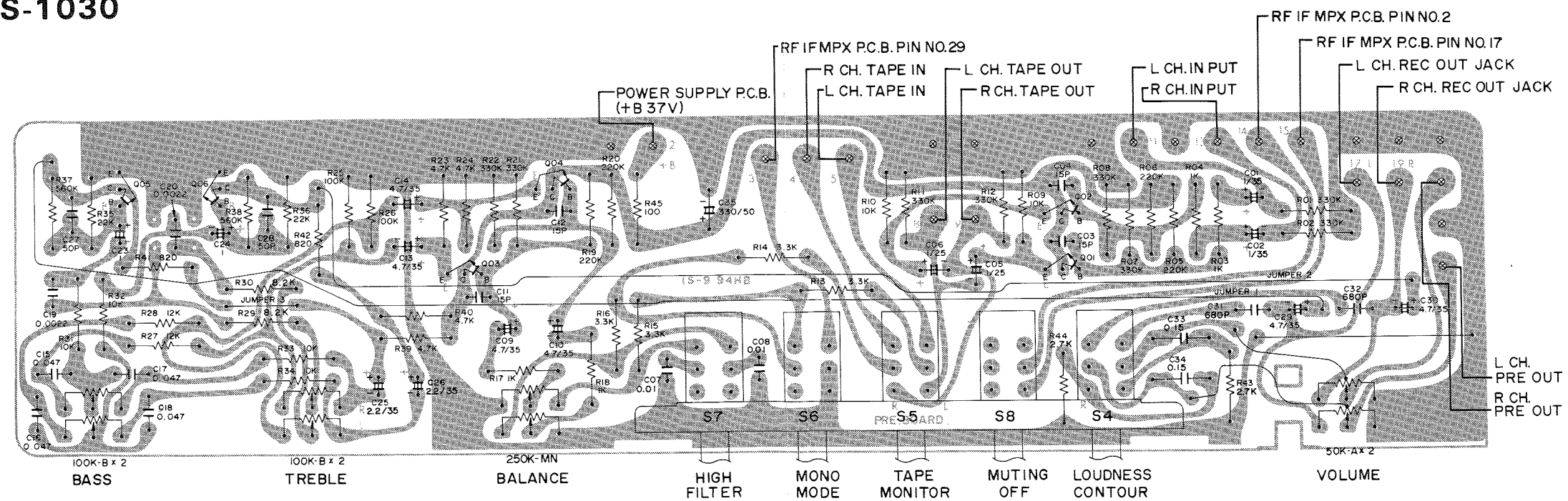

BOTTOM VIEW



# PARTS LIST

TONE PCB Assy

1310 4001 72130 (RS-1015, RS-1020)  
1310 4001 72131 (RS-1030)

Symbol No.	Part Number	Description
	4 2229 25380	VR-250K Balance
	4 2229 25390	VR-100K Bass/Treble
	4 2229 25370	VR-50K Volume (RS-1015) (RS-1020)
	4 2229 25410	VR-50K Volume (RS-1030)
S7	4 2319 34060	SW Push 5 Key High Filter, Mono Mode, Tape Monitor, Muting Off, Loudness Contour

### CAPACITORS

C01, 02	CL22305-3	Tantal 1 $\mu$ F 35V $\pm$ 20%
C03, 04	CK22344-9	Ceramic 15pF 50V $\pm$ 5%
C05, 06	CL22305-3	Tantal 1 $\mu$ F 35V $\pm$ 20%
C07, 08	CY22335-1	Mylar 0.01 $\mu$ F 50V $\pm$ 5%
C09, 10	CL22305-14	Tantal 4.7 $\mu$ F 35V $\pm$ 20%
C11, 12	CK22344-9	Ceramic 15pF 50V $\pm$ 5%
C13, 14	CL22305-14	Tantal 4.7 $\mu$ F 35V $\pm$ 20%
C15, 16	CY22335-22	Mylar 0.047 $\mu$ F 50V $\pm$ 5%
17, 18		
C19, 20	CY22335-21	Mylar 0.0022 $\mu$ F 50V $\pm$ 5%
C23, 24	CS22340-5	Sint, Alu, 1 $\mu$ F 25V $\pm$ 5%
C25, 26	CL22305-11	Tantal 2.2 $\mu$ F 35V $\pm$ 20%
C27, 28	CK0242011	Ceramic 50pF 50V $\pm$ 10%
C29, 30	CL22305-14	Tantal 4.7 $\mu$ F 35V $\pm$ 20%
C31, 32	CK22347-11	Ceramic 820pF 50V $\pm$ 10%
	(RS-1015, RS-1020)	
C31, 32	CK22347-10	Ceramic 680pF 50V $\pm$ 10%
	(RS-1030)	
C33, 34	CY22335-22	Mylar 0.047 $\mu$ F 50V $\pm$ 5%
	(RS-1015 RS-1020)	
C33, 34	CY22335-19	Mylar 0.15 $\mu$ F 50V $\pm$ 5%
	(RS-1030)	
C35	CE22342-27	Electrolytic 330 $\mu$ F 50V

Symbol No.	Part Number	Description
	<b>SEMICONDUCTORS</b>	
Q01, 02	TR2SC1570LH	2SC1570LH
03, 04		
05, 06		

### RESISTORS

R01, 02	RF25DC334J	Carbon 330K 1/4W $\pm$ 5%
R03, 04	RF25DC102J	Carbon 1K 1/4W $\pm$ 5%
R05, 06	RF25DC224J	Carbon 220K 1/4W $\pm$ 5%
R07, 08	RF25DC334J	Carbon 330K 1/4W $\pm$ 5%
R09, 10	RF25DC103J	Carbon 10K 1/4W $\pm$ 5%
R11, 12	RF25DC334J	Carbon 330K 1/4W $\pm$ 5%
R13, 14	RF25DC332J	Carbon 3.3K 1/4W $\pm$ 5%
R15, 16	RF25DC332J	Carbon 3.3K 1/4W $\pm$ 5%
R17, 18	RF25DC102J	Carbon 1K 1/4W $\pm$ 5%
R19, 20	RF25DC224J	Carbon 220K 1/4W $\pm$ 5%
R21, 22	RF25DC334J	Carbon 330K 1/4W $\pm$ 5%
R23, 24	RF25DC472J	Carbon 4.7K 1/4W $\pm$ 5%
R25, 26	RF25DC104J	Carbon 100K 1/4W $\pm$ 5%
R27, 28	RF25DC123J	Carbon 12K 1/4W $\pm$ 5%
R29, 30	RF25DC822J	Carbon 8.2K 1/4W $\pm$ 5%
R31, 32	RF25DC103J	Carbon 10K 1/4W $\pm$ 5%
	33, 34	
R35, 36	RF25DC223J	Carbon 22K 1/4W $\pm$ 5%
R37, 38	RF25DC564J	Carbon 560K 1/4W $\pm$ 5%
R39, 40	RF25DC472J	Carbon 4.7K 1/4W $\pm$ 5%
R41, 42	RF25DC821J	Carbon 820 1/4W $\pm$ 5%
R43, 44	RF25DC682J	Carbon 6.8k 1/4W $\pm$ 5%
	(RS-1015, RS1020)	
R43, 44	RF25DC272J	Carbon 2.7k 1/4W $\pm$ 5%
	(RS-1030)	
R45	RF25DC101J	Carbon 100 1/4W $\pm$ 5%

# EQ P.C. BOARD

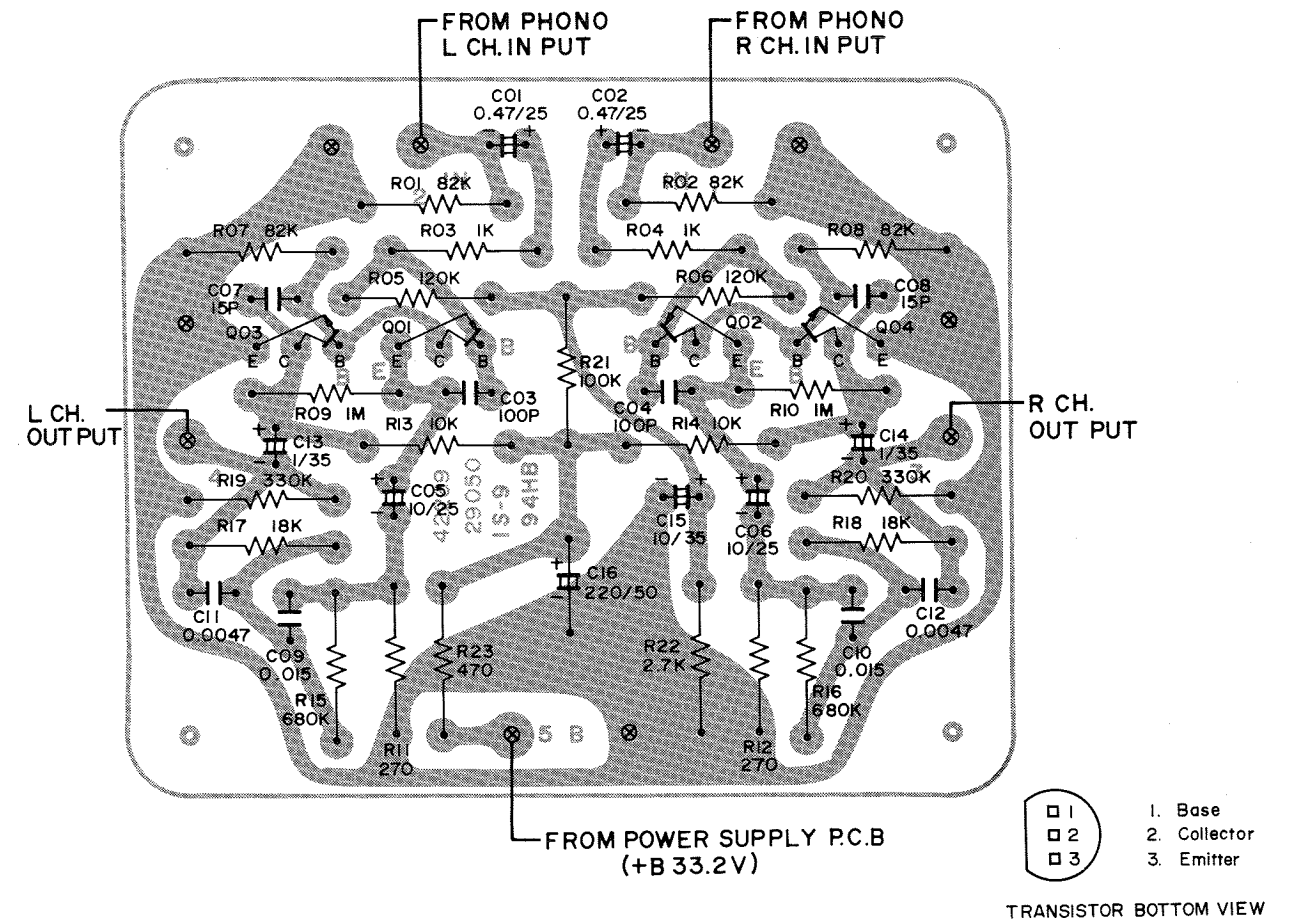

## BOTTOM VIEW

TRANSISTOR DC VOLTAGES				
SYMBOL No.	DEVICE	B	C	E
Q01, 02	2SA763E	0.74	0.58	1.3
Q03, 04	2SC1570LH	0.58	11	0

# PARTS LIST

EQ PCB Assy  
1310 4001 72120

Symbol No.	Part Number	Description	Symbol No.	Part Number	Description
<b>CAPACITORS</b>					
C01, 02	CS22340-5	Sint, Alu 0.47 $\mu$ F 25V $\pm$ 20%	R01, 02	RF25DC823J	Carbon 82K 1/4W $\pm$ 5%
C03, 04	CK222347-1	Ceramic 100pF 50V $\pm$ 20%	R03, 04	RF25DC102J	Carbon 1K 1/4W $\pm$ 5%
C05, 06	CE1252621	Electrolytic 10 $\mu$ F 25V	R05, 06	RF25DC124J	Carbon 120K 1/4W $\pm$ 5%
C07, 08	CK22344-9	Ceramic 15pF 50V $\pm$ 5%	R07, 08	RF25DC823J	Carbon 82K 1/4W $\pm$ 5%
C09, 10	CY22335-2	Mylar 0.015 $\mu$ F 50V $\pm$ 5%	R09, 10	RF25DC105J	Carbon 1M 1/4W $\pm$ 5%
C11, 12	CY22335-8	Mylar 0.0047 $\mu$ F 50V $\pm$ 5%	R11, 12	RF25DC271J	Carbon 270 1/4W $\pm$ 5%
C13, 14	CL22305-3	Tantal 1 $\mu$ F 35V $\pm$ 20%	R13, 14	RF25DC103J	Carbon 10K 1/4W $\pm$ 5%
C15	CIVTRM106A	Tantal 10 $\mu$ F 35V $\pm$ 20%	R15, 16	RF25DC684J	Carbon 680K 1/4W $\pm$ 5%
C16	CE22342-26	Electrolytic 220 $\mu$ F 50V	R17, 18	RF25DC183J	Carbon 18K 1/4W $\pm$ 5%
<b>SEMICONDUCTORS</b>					
Q01, 02	TR2SA763E	2SA763E	R19, 20	RF25DC334J	Carbon 330K 1/4W $\pm$ 5%
Q03, 04	TR2SC1570LH	2SC1570LH	R21	RF25DC104J	Carbon 100K 1/4W $\pm$ 5%
			R22	RF25DC272J	Carbon 2.7K 1/4W $\pm$ 5%
			R23	RF25DC471J	Carbon 470 1/4W $\pm$ 5%

# POWER AMP P.C.BOARD

RS-1015

RS-1020

RS-1030

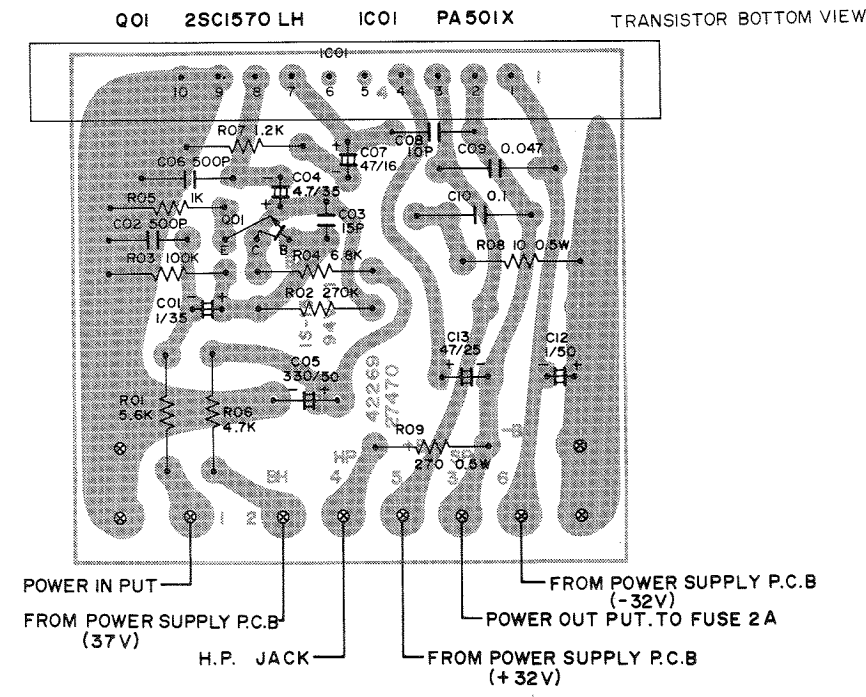
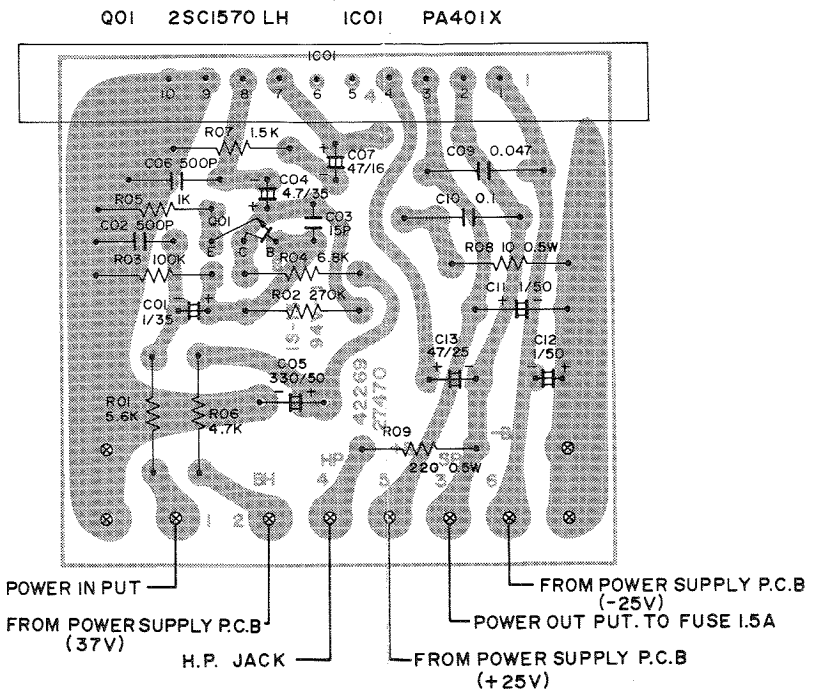
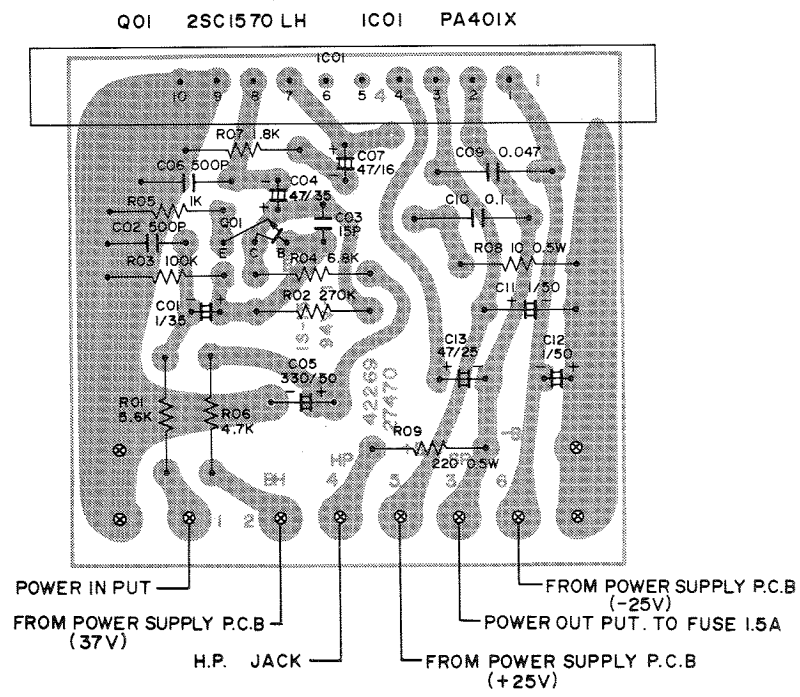
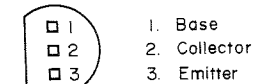

TRANSISTOR DC VOLTAGES				
SYMBOL No.	DEVICE	B	C	E
Q01	2SC1570LH	2.8	11.6	2.2

PIN NUMBERS & VOLTAGES											
IC01 PA401X		1	2	3	4	5	6	7	8	9	10
		-25	0	25	12.8			0.086	0.08	0	

PIN NUMBERS & VOLTAGES											
IC01 PA501X		1	2	3	4	5	6	7	8	9	10
		-32	0	32	16.6			0.086	0.08	0	

BOTTOM VIEW

## POWER AMP IC EQUIVALENT CIRCUIT

## PARTS LIST

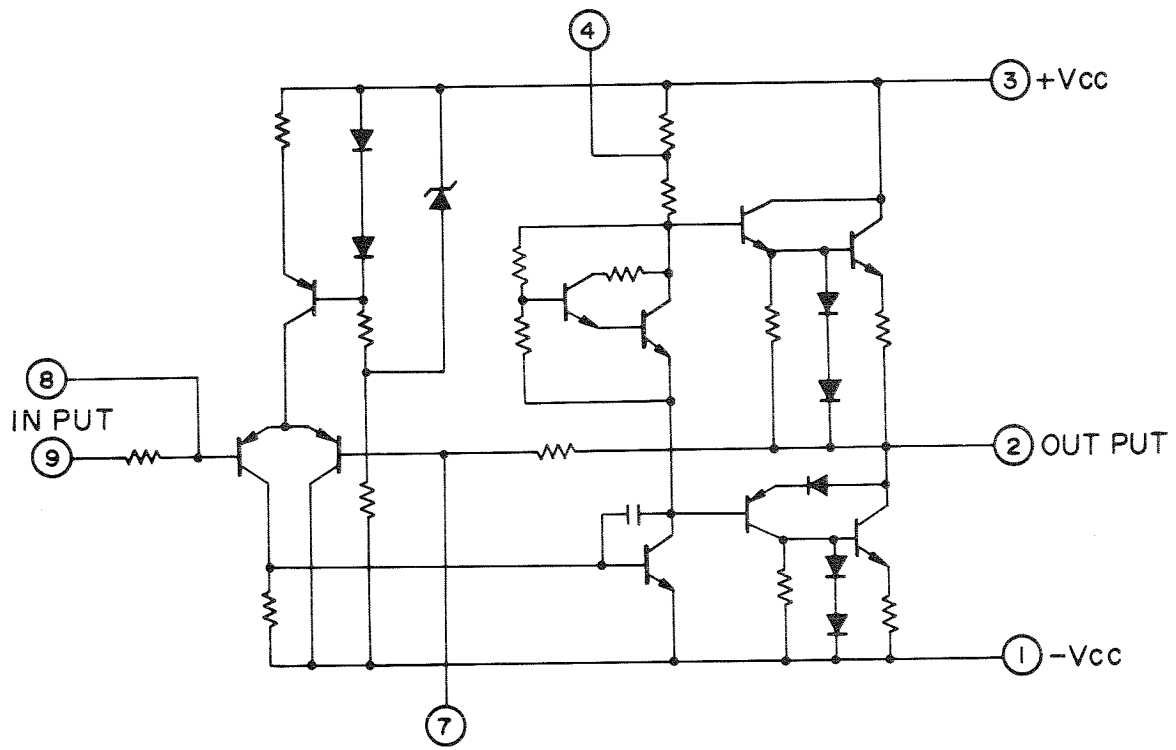

POWER AMP PCB Assy  
 1310 4001 72150 (RS-1015)  
 1310 4001 72151 (RS-1020)  
 1310 4001 72152 (RS-1030)

Symbol No.	Part Number	Description
<b>CAPACITORS</b>		
C01	CL22305-3	Tantal 1 $\mu$ F 35V $\pm$ 20%
C02	CK22351-3	Ceramic 500pF 50V $\pm$ 10%
C03	CK22344-9	Ceramic 15pF 50V $\pm$ 5%
C04	CL22305-14	Tantal 4.7 $\mu$ F 35V $\pm$ 20%
C05	CIHRB337A	Electrolytic 330 $\mu$ F 50V
C06	CK22351-3	Ceramic 500pF 50V $\pm$ 10%
C07	CE1252515	Electrolytic 47 $\mu$ F 16V
C08	CK22344-32	Ceramic 10pF 50V (RS-1030)
C09	C2YFRK473B	Mylar 0.047 $\mu$ F 150V $\pm$ 10%
C10	CY22335-18	Mylar 0.1 $\mu$ F 50V $\pm$ 20%
C11, 12	CE22342-2	Electrolytic 1 $\mu$ F 50V (RS-1015, RS-1020)
C12	CE22342-2	Electrolytic 1 $\mu$ F 50V (RS-1030)
C13	CE0252625 42349 21230	Electrolytic 47 $\mu$ F 25V Relay Thermal (RS-1030)

SEMICONDUCTORS		
Symbol No.	Part Number	Description
IC01	TR09023	PA401X (RS-1015, RS-1020)
IC01	TR09024	PA501X (RS-1030)
Q01	TR2SC1570LH	2SC1570 LH
<b>RESISTORS</b>		
R01	RF25DC562J	Carbon 5.6K 1/4W $\pm$ 5%
R02	RF25DC274J	Carbon 270K 1/4W $\pm$ 5%
R03	RF25DC104J	Carbon 100K 1/4W $\pm$ 5%
R04	RF25DC682J	Carbon 6.8K 1/4W $\pm$ 5%
R05	RF25DC102J	Carbon 1K 1/4W $\pm$ 5%
R06	RF25DC472J	Carbon 4.7K 1/4W $\pm$ 5%
R07	RF25DC182J	Carbon 1.8k 1/4W $\pm$ 5%
R07	RF25DC152J	Carbon 1.5k 1/4W $\pm$ 5%
R07	RF25DC122J	Carbon 1.2k 1/4W $\pm$ 5%
R08	RC20RF100J	Carbon 10 1/2W $\pm$ 10%
R09	R50DC221J	Metal Oxide Film 220 1/2W $\pm$ 10% (RS-1015, RS-1020)
R09	R50DC271J	Metal Oxide Film 270 1/2W $\pm$ 10% (RS-1030)

# POWER SUPPLY P.C.BOARD

DOI ~ O4 SR3AM D05 1N4002 D06 WZ130 Q01 2SD330 E

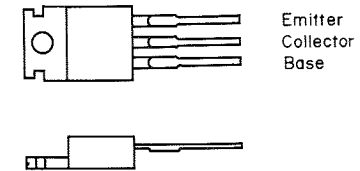
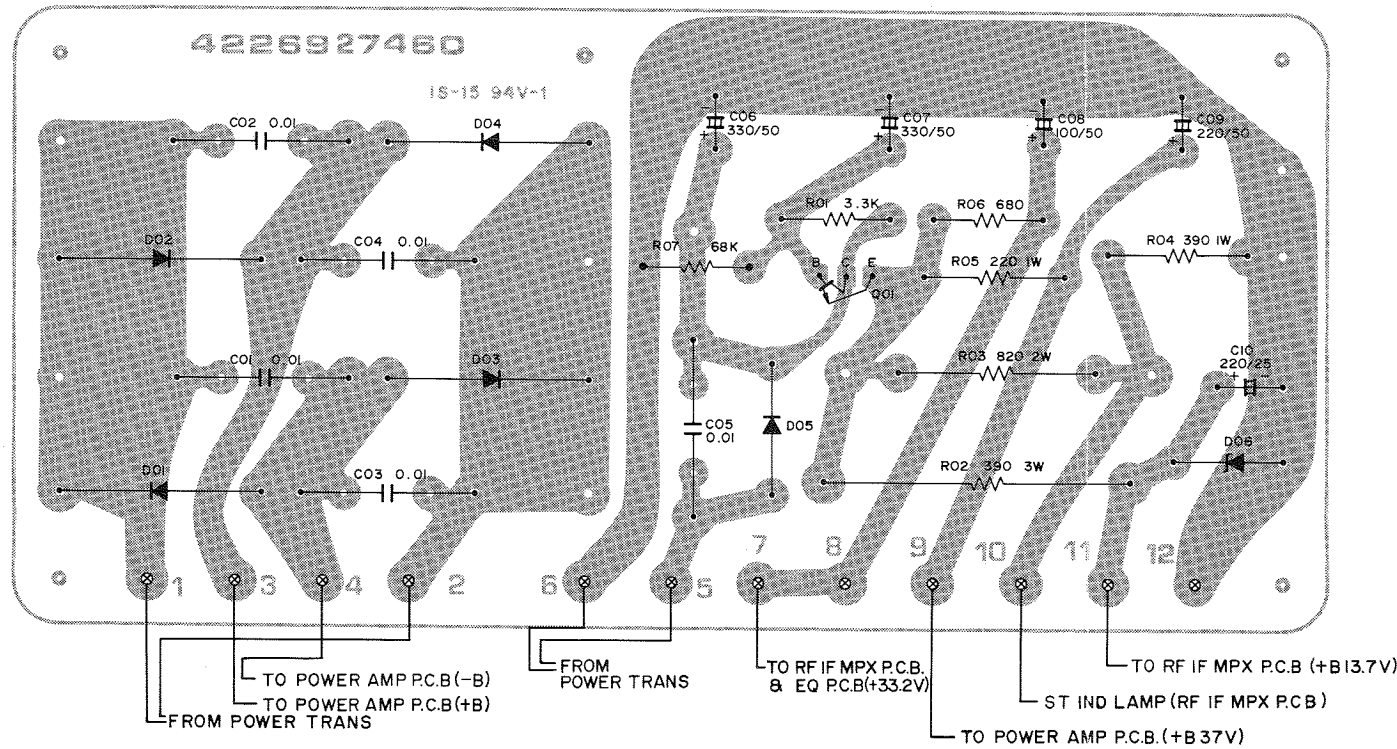

# PARTS LIST

POWER SUPPLY PCB Assy  
1310 4001 72140

Symbol No.	Part Number	Description
<b>CAPACITORS</b>		
C01, 02	CK22359-1	Ceramic 0.01 $\mu$ F 500V +100 -0%
03, 04		
05		
C06, 07	CE22342-27	Electrolytic 330 $\mu$ F 50V
C08	CE22342-9	Electrolytic 100 $\mu$ F 50V
C09	CE22342-26	Electrolytic 220 $\mu$ F 50V
C10	CE22342-14	Electrolytic 220 $\mu$ F 25V
<b>SEMICONDUCTORS</b>		
D01, 02	TRSR3AM	Diode SR3AM
03, 04		
D05	TR1N4002	Diode 1N4002
D06	TRWZ130	Diode WZ-130
Q01	TR2SD330E	2SD330E
<b>RESISTORS</b>		
R01	RF25DC332J	Carbon 3.3K 1/4W $\pm$ 5%
R02	RPG3W391K	Metal Oxide Film 390 3W $\pm$ 10%
R03	RW200W821J	Metal Oxide Film 820 2W $\pm$ 10%
R04	RW200W391J	Metal Oxide Film 390 1W $\pm$ 10%
R05	0111410	Metal Oxide Film 220 1W $\pm$ 10%
R06	RF25DC681J	Carbon 680 1/4W $\pm$ 5%
R07	RF25DC683J	Carbon 68K 1/4W $\pm$ 5%

SYMBOL No.	DEVICE	B	C	E
Q01	2SD330E	42.6	44.7	42

# DIAL LAMP P.C.BOARD

RS-1015

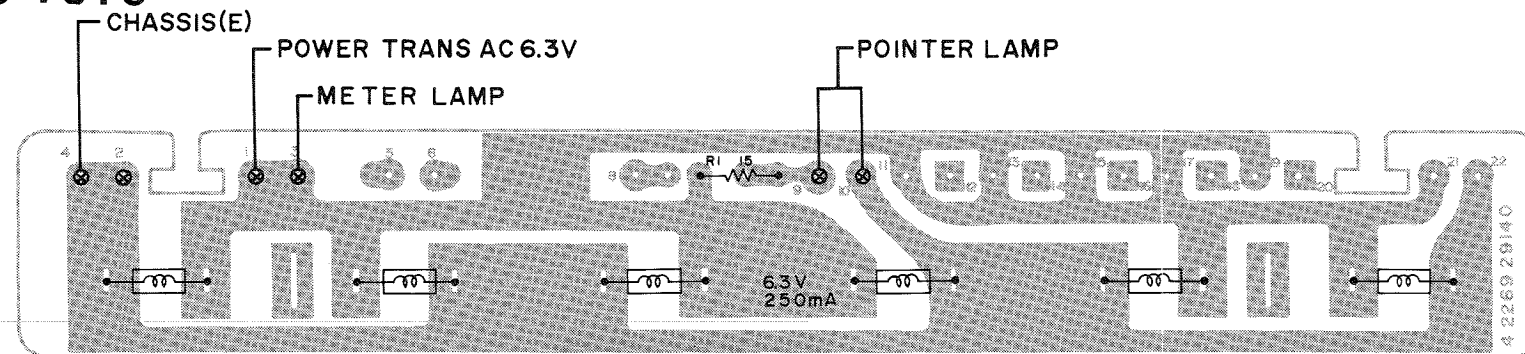

RS-1020 RS-1030

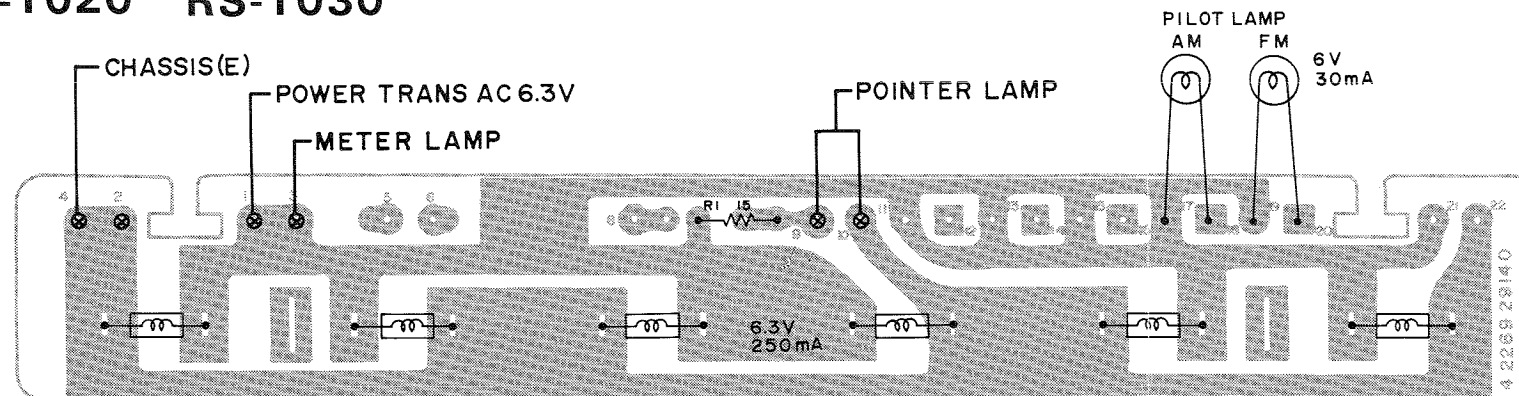

# BOTTOM VIEW

DIAL LAMP PCB Assy  
1310 4001 72160 (RS-1015)  
1310 4001 72161 (RS-1020, RS-1030)

Symbol No.	Part Number	Description
	4 2359 20930	Lamp Holder
	LM2767201	Pilot Lamp, Fuse type 6.3V 250mA
	LM4612920726	Pilot Lamp AM, FM ind 6V 30mA (RS-1020, RS-1030)
<b>RESISTORS</b>		
R01	RF25DC150J	Carbon 15 1/4W $\pm$ 5%

**EXPLODED VIEW OF CABINET  
AND CHASSIS FRONT MOUNTED ASSEMBLIES  
RS-1015**

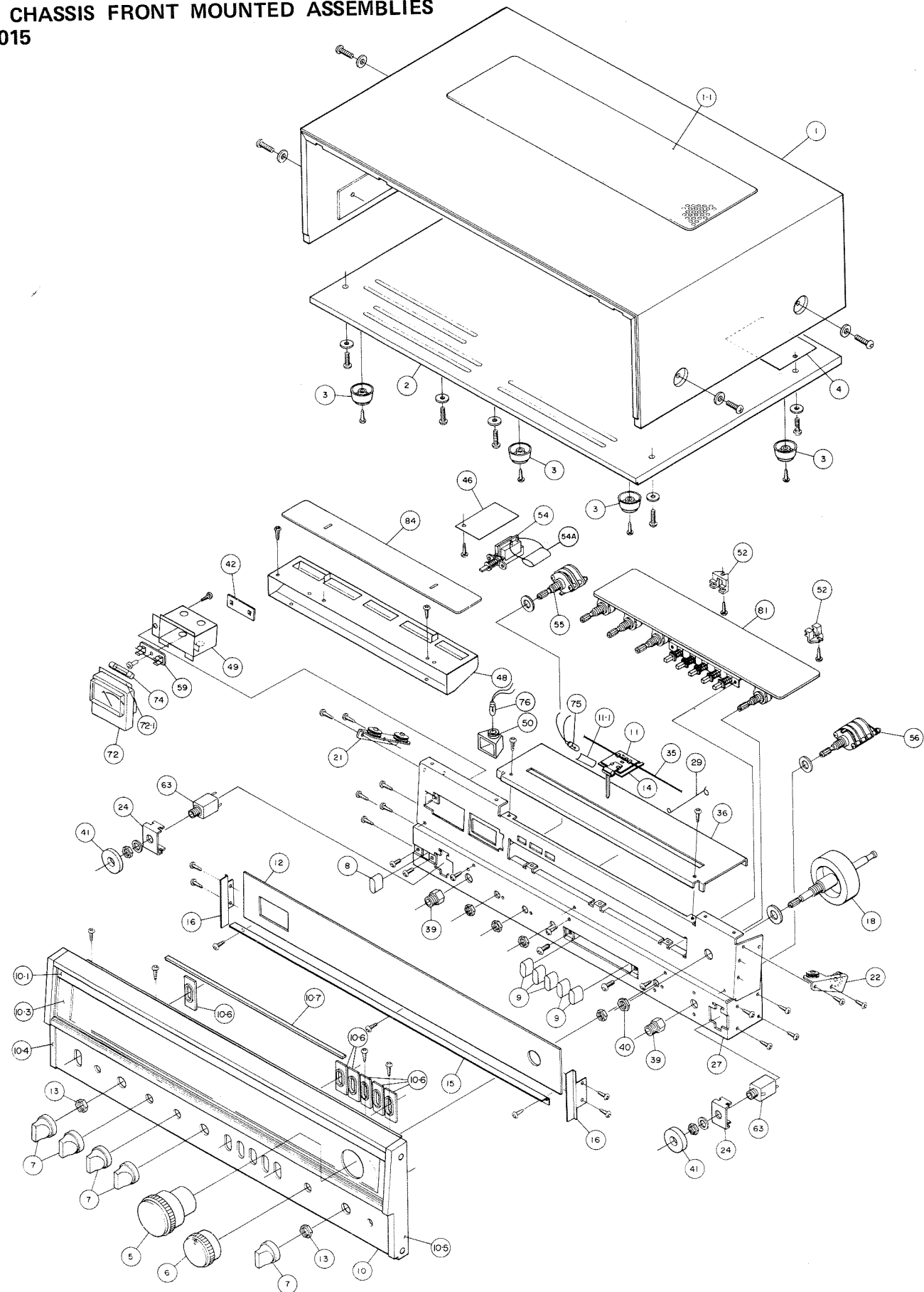

**EXPLODED VIEW OF CHASSIS  
AND REAR MOUNTED ASSEMBLIES  
RS-1015**

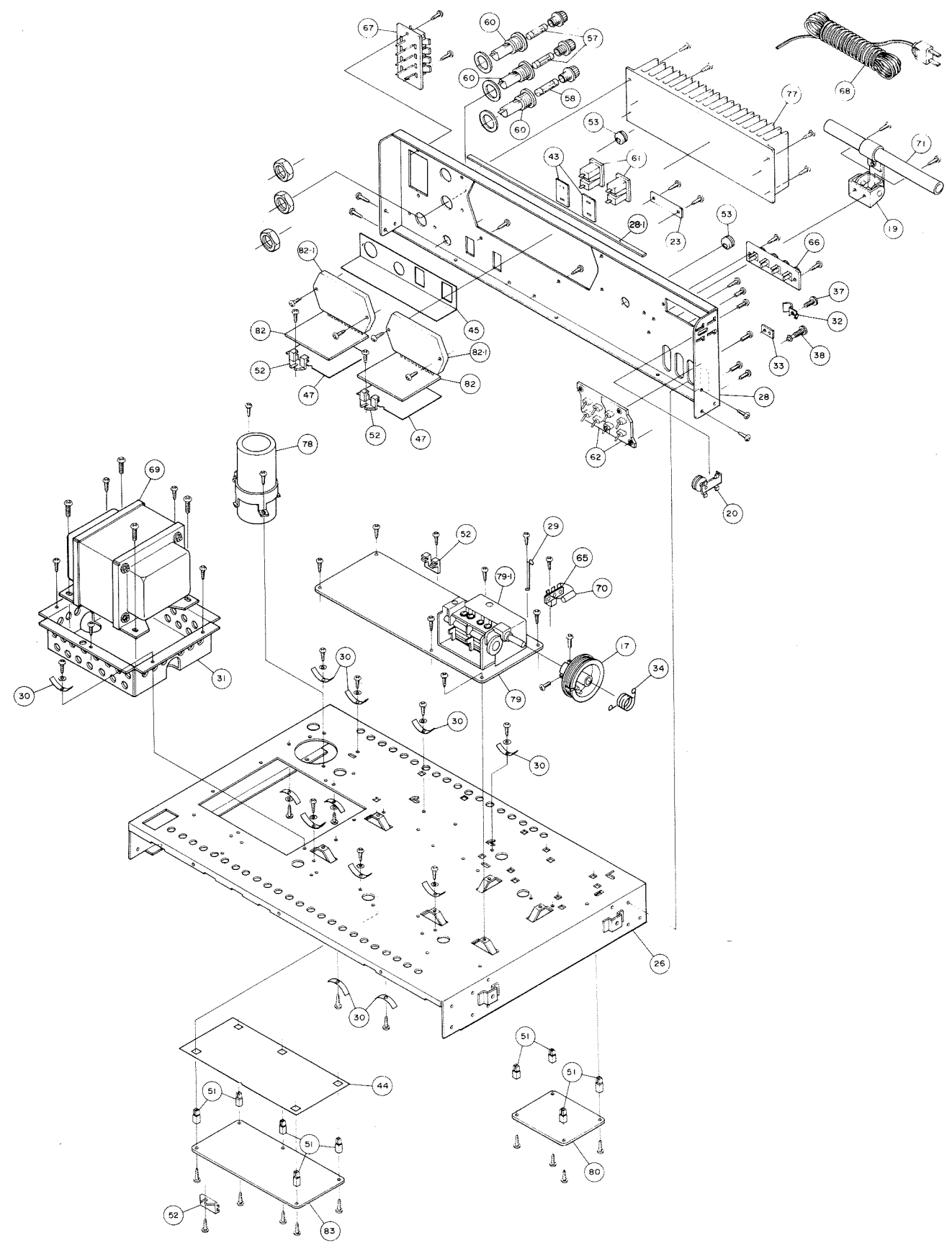

# SCHEMATIC DIAGRAM

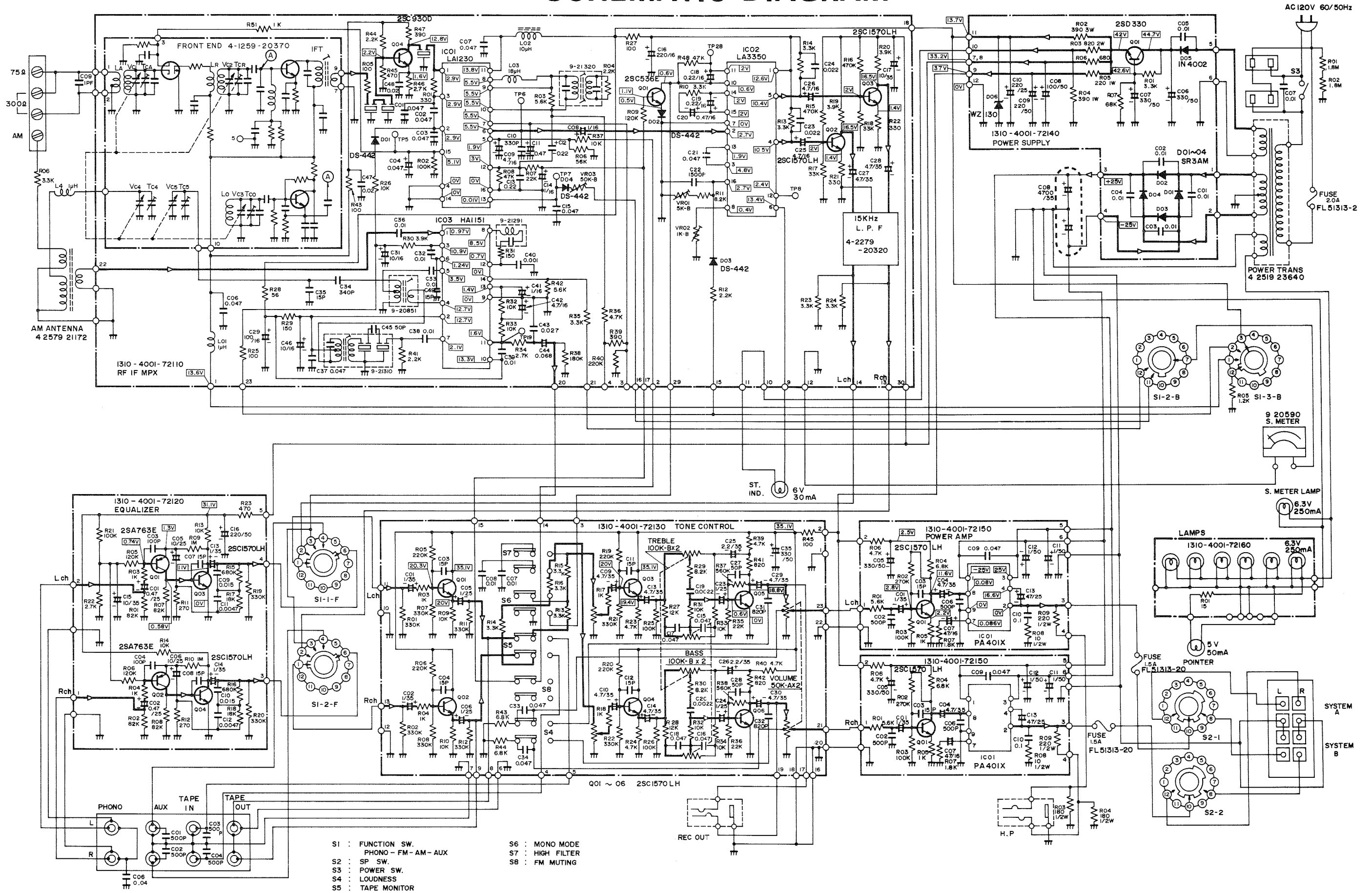

- S1 : FUNCTION SW.
- S2 : PHONO - FM - AM - AUX
- S3 : SP SW.
- S4 : POWER SW.
- S5 : LOUDNESS
- S6 : MONO MODE
- S7 : HIGH FILTER
- S8 : FM MUTING

EXPLODED VIEW OF CABINET  
AND CHASSIS FRONT MOUNTED ASSEMBLIES  
RS-1020

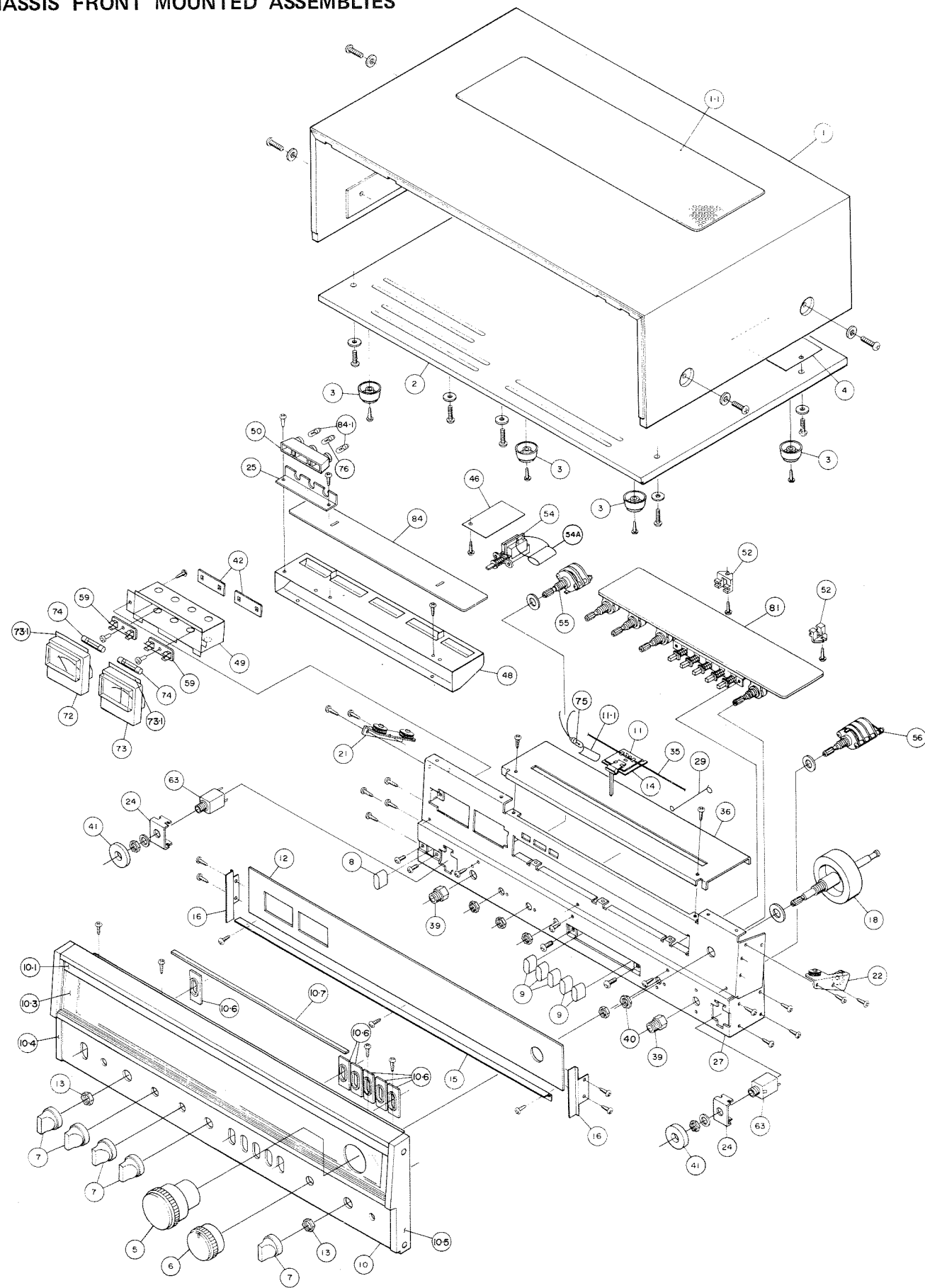

EXPLODED VIEW OF CHASSIS  
AND REAR MOUNTED ASSEMBLIES  
RS-1020

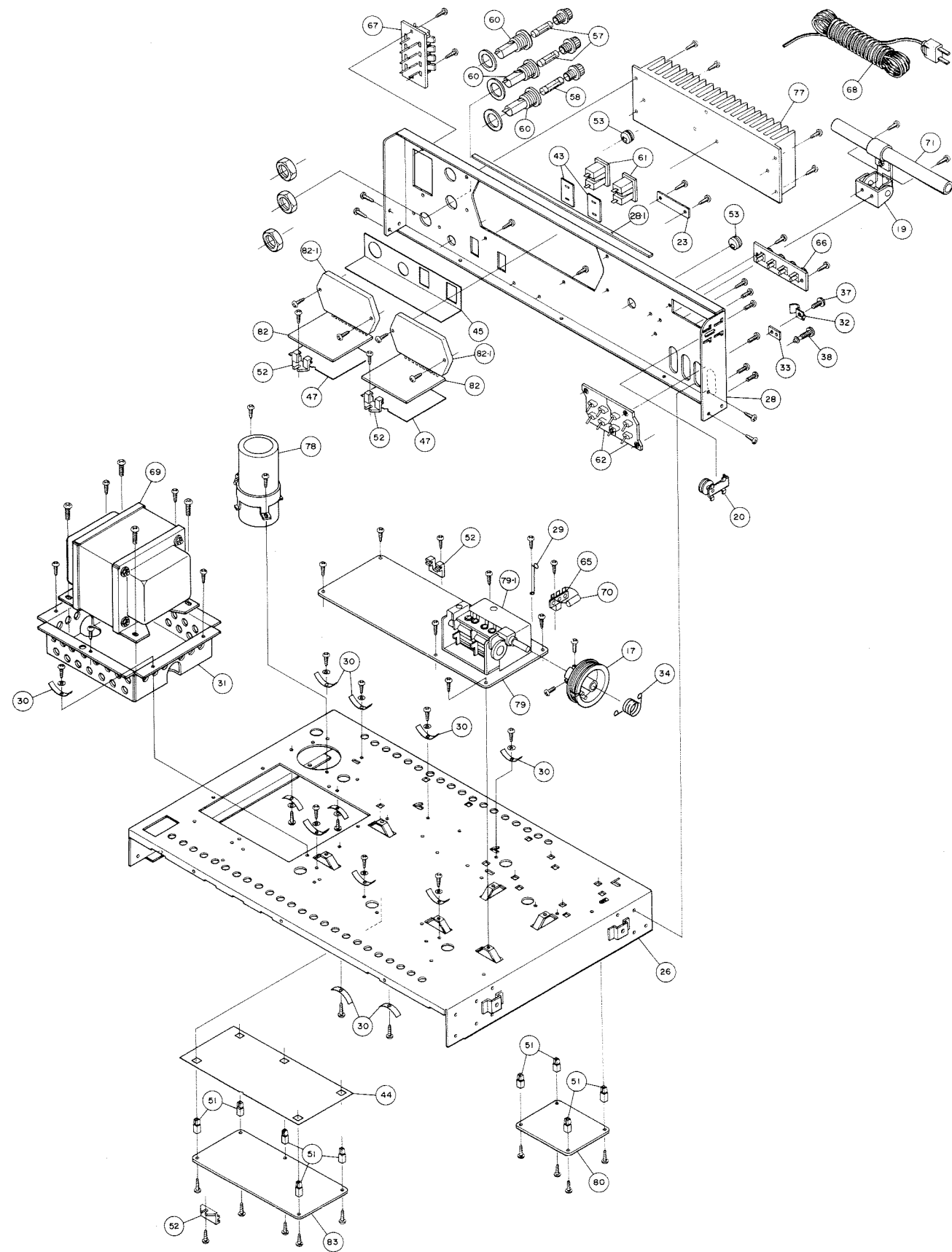

# SCHEMATIC DIAGRAM

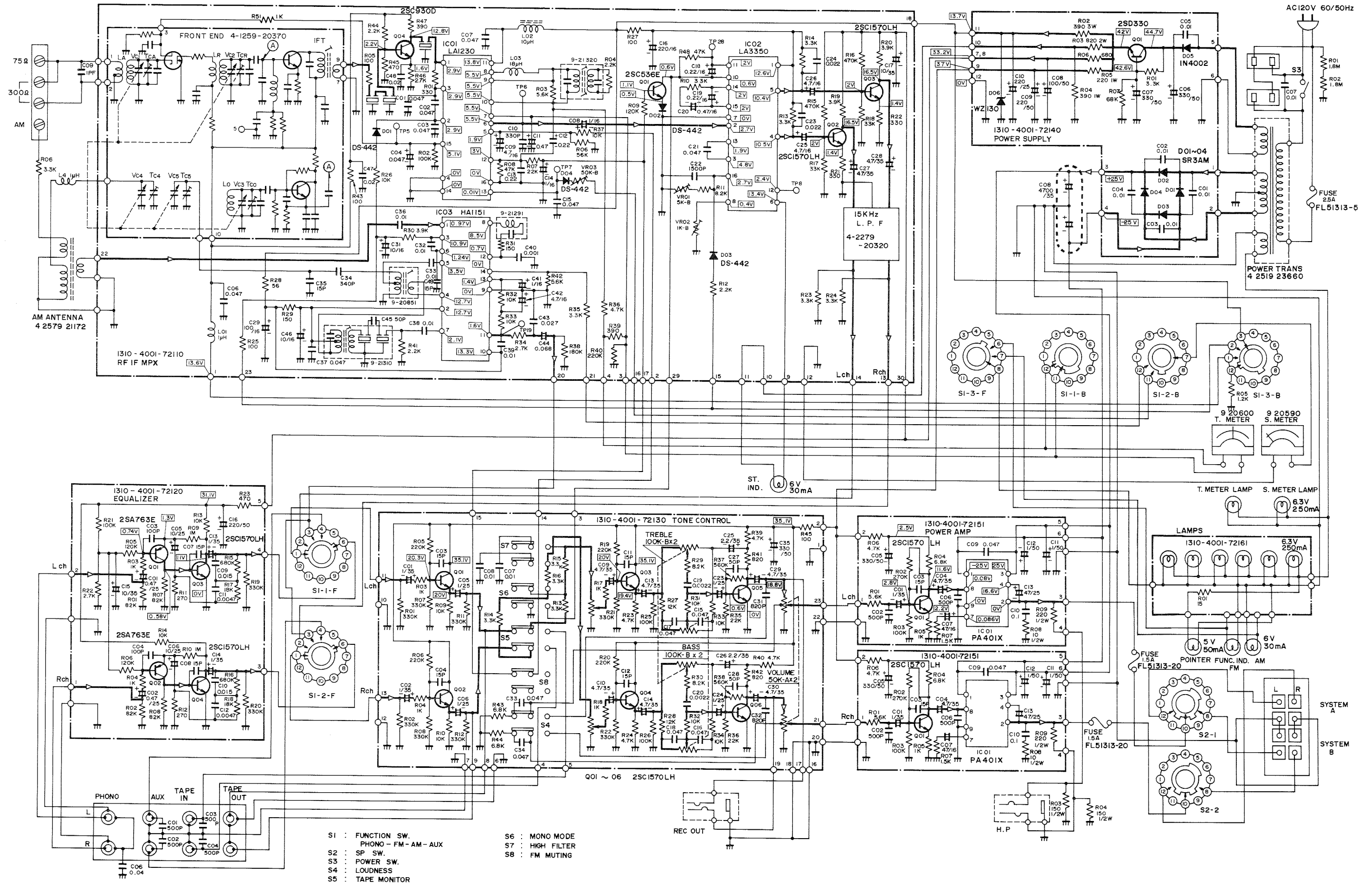

- S1 : FUNCTION SW.  
PHONO - FM - AM - AUX
- S2 : SP SW.
- S3 : POWER SW.
- S4 : LOUDNESS
- S5 : TAPE MONITOR
- S6 : MONO MODE
- S7 : HIGH FILTER
- S8 : FM MUTING

EXPLODED VIEW OF CABINET  
AND CHASSIS FRONT MOUNTED ASSEMBLIES  
RS-1030

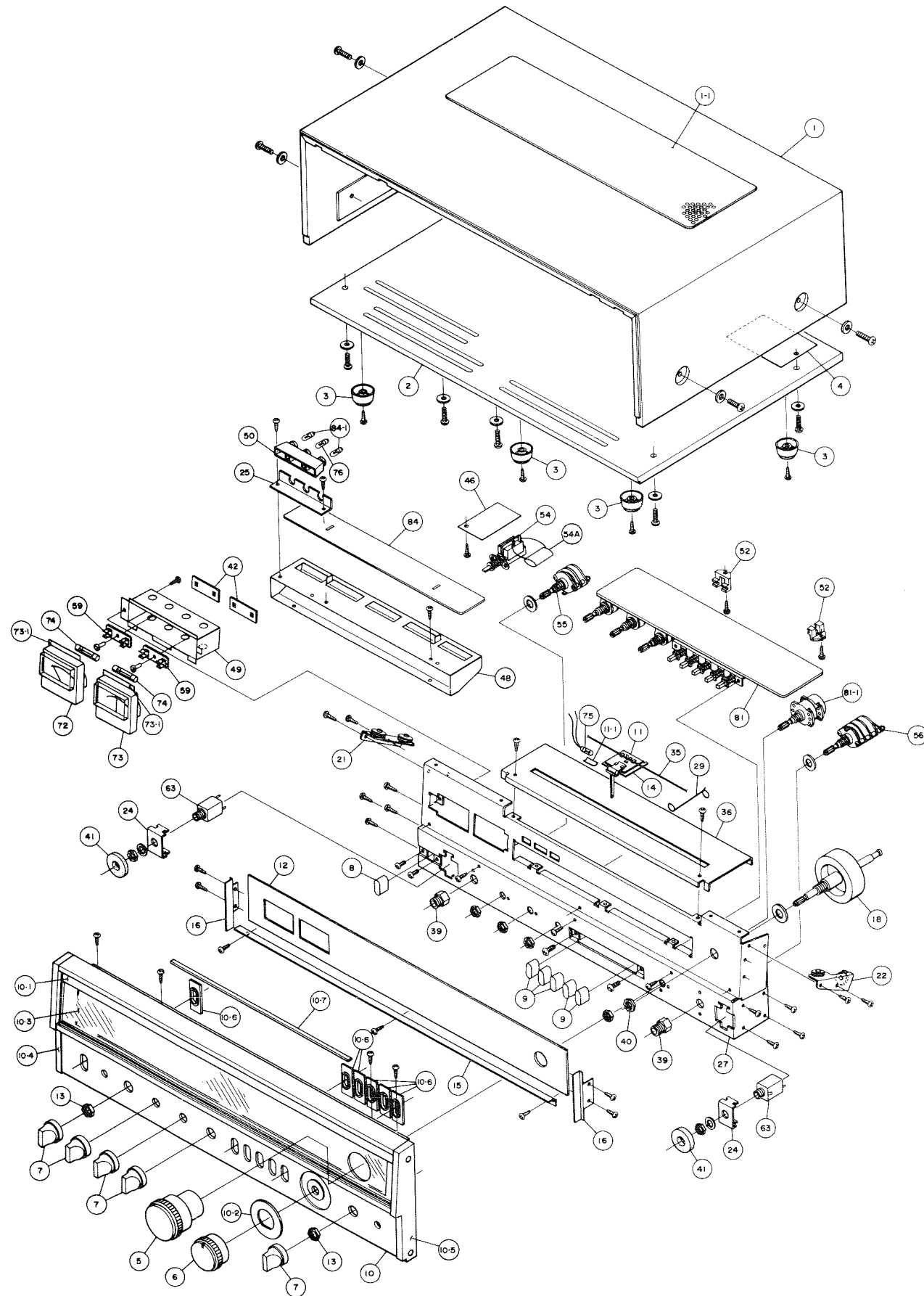

EXPLODED VIEW OF CHASSIS  
AND REAR MOUNTED ASSEMBLIES  
RS-1030

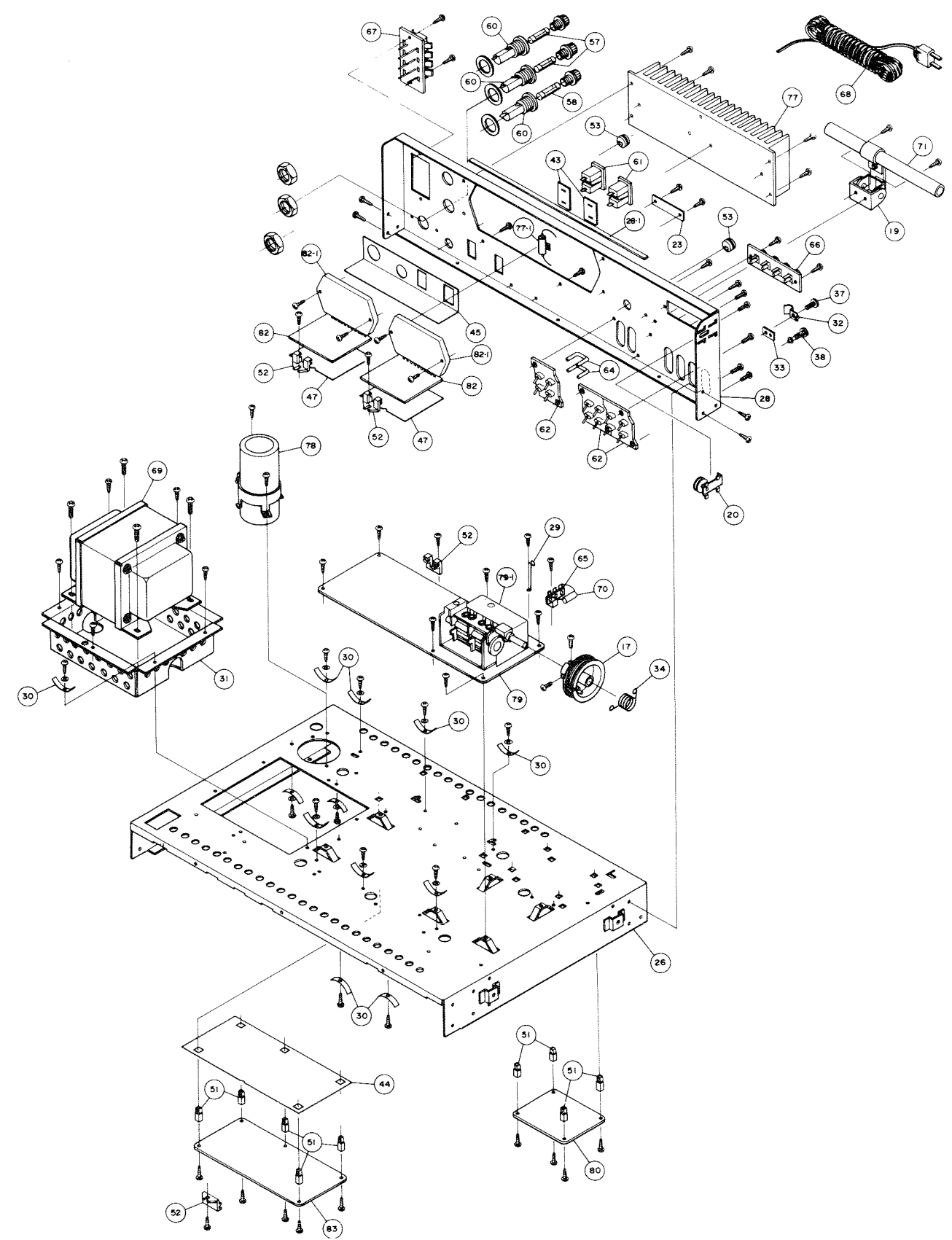



# SCHEMATIC DIAGRAM

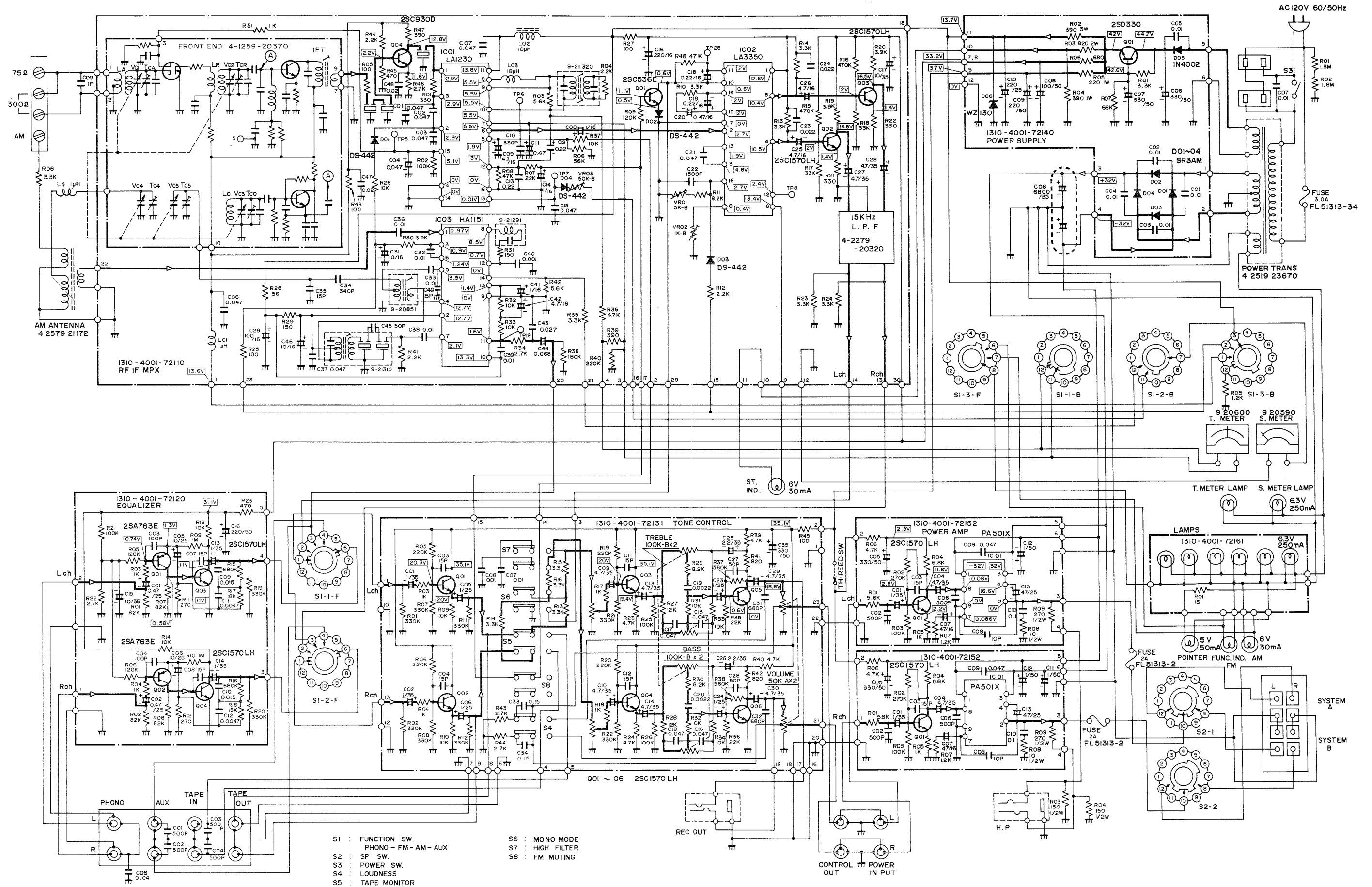

- SI : FUNCTION SW.  
    PHONO - FM - AM - AUX
- S2 : SP SW.
- S3 : POWER SW.
- S4 : LOUDNESS
- S5 : TAPE MONITOR
- S6 : MONO MODE
- S7 : HIGH FILTER
- S8 : FM MUTING

# PARTS LIST

## CABINET PARTS LIST

Symbol No.	Part Number	Description
1A	1310 1101 08400	Cabinet Assy
1 *	1312 1101 32000	Cabinet P/O 1A
1 - 1 *	1312 1312 11003	Grill P/O 1A
2 *	1312 1105 17100	Plate, Bottom
3 *	1312 1801 13200	Leg
4 *	1312 6101 21900	Shield

## APPEARANCE PARTS LIST

Symbol No.	Part Number	Description
5	1310 1001 35300	Knob, Tuning
6	1310 1001 35400	Knob, Volume
7	1310 1001 35500	Knob, Controls
8	1310 1001 35600	Knob, Push, Power Switch
9	1310 1001 35700	Knob, Push, Button
10	1310 1016 22600	Dress Panel Assy (RS-1015)
10	1310 1016 22601	Dress Panel Assy (RS-1020)
10	1310 1016 22602	Dress Panel Assy (RS-1030)
10 - 1 *	1312 1110 18400	Insert "RS-1015"
10 - 2 *	1312 1110 18500	Volume Level Plate, RS-1030, P/O 10
10 - 1 *	1312 1110 18401	Insert "RS-1020" P/O 10
10 - 1 *	1312 1110 18402	Insert "RS-1030" P/O 10
10 - 3 *	1312 1205 16300	Window P/O 10
10 - 4 *	1312 1311 35900	End Strip (Left) P/O 10
10 - 5 *	1312 1311 35901	End Strip (Right) P/O 10
10 - 6 *	1312 6113 23300	Bushing P/O 10
10 - 7 *	1312 5205 16700	Cushion P/O 10
11	1310 3011 16500	Dial Pointer Assy
11 - 1 *	1312 6308 16400	Filter, Dial Pointer
12	1312 1201 28100	Dial Plate (RS-1015)
12	1312 1201 28101	Dial Plate (RS-1020)
12	1312 1201 28102	Dial Plate (RS-1030)
14 *	1312 5205 16800	Cushion, Dial Pointer
15 *	1312 6113 23400	Shelter, Bottom, Dial Plate
16 *	1312 6113 23500	Shelter, Left/Right; Dial Plate

## CHASSIS PARTS LIST

Symbol No.	Part Number	Description
18	1310 3003 19100	Tuning Shaft Assy
19	1310 3008 11702	Support, Antenna Assy
20 *	1310 3020 05800	Pully Assy Rear
21 *	1310 3020 06900	Pully Assy Left Front
22 *	1310 3020 07000	Pully Assy Right Front
23 *	1312 1310 23200	Nameplate, Rear
24 *	1312 3101 38000	Mounting Bracket, (Head Phone Jack)
26 *	1312 3301 21800	Chassis
27 *	1312 3305 20000	Front Panel (RS-1015)
27 *	1312 3305 20001	Front Panel (RS-1020, RS-1030)
28 *	1312 3306 22200	Rear Panel (RS-1015)
28 *	1312 3306 22201	Rear Panel (RS-1020)
28 *	1312 3306 22202	Rear Panel (RS-1030)
28 - 1 *	1312 5205 16700	Cushion

Symbol No.	Part Number	Description
29 *	1312 3608 10800	Wire Clamp
30 *	1312 3608 12700	Wire Clamp
31 *	1312 3617 15100	Mounting Bracket, Power Transformer
32	1312 3621 00400	Clamp, 75 ohm Coax
33	1312 3621 00500	Base, Coax Clamp
36 *	1312 4120 11300	Slide Rail, Dial Pointer
37 *	1312 4201 12701	Screw, Coax Clamp
38 *	1312 4201 15400	Screw, Ground
39 *	1312 4202 14100	Nut, Function Switch Mounting
40 *	1312 4202 14200	Nut, Tuning Shaft Assy Mounting
53 *	1312 6111 14200	Bushing, line Cord
54(S3)	4 2319 23901	Switch, Power
55(S2)	4 2319 34020	Switch, Rotary, Speaker
56(S1)	4 2319 34030	Switch, Rotary, Function
60	4 2359 21110	Fuse Holder, Rear
61	4 2359 21960	AC Receptacle
62	4 2359 22710	Rear Accessory Jacks
63	4 2359 22730	Jack, Phones/Record Out
64	4 2369 21220	Shorting Plug
65 *	4 2379 20140	Terminal Strip
66	4 2379 21460	Terminal, Antenna Connector
67	4 2379 21560	Terminal, Speakers Connector
69(T1)	4 2519 23640	Power Transformer (RS-1015)
69(T1)	4 2519 23660	Power Transformer (RS-1020)
69(T1)	4 2519 23670	Power Transformer (RS-1030)
77 *	1312 6201 22800	Heat Sink (RS-1015)
77 *	1312 6201 21801	Heat Sink (RS-1020, RS-1030)
78(C08)	4 2239 20970	Cap Elect 4700MF 35V (RS-1015,RS-1020)
78(C08)	4 2239 20980	Cap Elect 6800MF 35V (RS-1030)

NOTE: \* Asterisk indicates not a service part

# PARTS LIST

## MISC. PARTS LIST

Symbol No.	Part Number	Description
17	1310 3002 11300	Drum Assy, Tuning Gang
34	1312 4111 00400	Tension Spring
35 *	1312 4112 10200	Dial Cord
41 *	1312 4208 16400	Spacer Cushion, Head Phone Jack
42 *	1312 6107 13900	Insulator, Meter Lamp
43 *	1312 6107 19300	Insulator, AC Recept
44 *	1312 6107 21400	Insulator P.C.B.
45 *	1312 6107 21500	Insulator, Rear Panel
46 *	1312 6107 21600	Insulator, P.C.B.
47 *	1312 6107 21700	Insulator, P.C.B.
48 *	1312 6110 23700	Housing, Dial Lamp P.C.B
49 *	1312 6110 25700	Housing, Meter Lamp
50 *	1312 6111 12100	Housing, Stereo Beacon Lamp
51 *	1312 3614 17101	P.C.B. Mounting Clip
52 *	1312 3614 18300	P.C.B. Mounting Clam
54A (C07)	CK22359-1	Capacitor, Ceramic, 0.01 $\mu$ F 500V
57	FL51313-20	Fuse, 1.5A 125V Slo-Blo Speaker(RS-1015, RS-1020)
57	FL51313-2	Fuse, 2A 125V Slo-Blo Speaker (RS-1015,1020,1030)
58	FL51313-2	Fuse, 2A 125V Slo-Blo Power (RS-1015)
58	FL51313-5	Fuse, 2.5A 125V Slo-Blo Power (RS-1020)
58	FL51313-34	Fuse, 3A 125V Slo-Blo Power (RS-1030)
59	4 2359 20160	Holder, Lamp
68 *	4 2439 20720	Line Cord
70(L04)	4 2539 20120	IF Trap Coil 1 $\mu$ F
71	4 2579 21172	AM Antenna
72(M-1)	4 5119 20590	Meter, Signal Strenth
72-1 *	1312 1406 12300	Plate Color (RS-1015)
73(M-2)	4 5119 20600	Meter, Center of Channel (RS-1020,RS-1030)
73-1 *	1312 1406 12300	Plate Color (RS-1020, RS-1030)
74	LM2767201	Lamp, Meter/Dial 6.3V 250MA
75	4 6129 20592	Lamp, Pointer 5V 50mA
76	4 6129 20726	Lamp, Stereo Indicator 6V 30mA
77-1	4 2349 21230	Thermal Relay (RS-1030)

Symbol No.	Part Number	Description
79 *	1310 4001 72110	RF IF MPX P.C.B. Assy
80 *	1310 4001 72120	Equaliser P.C.B. Assy
81 *	1310 4001 72130	Tone P.C.B. Assy (RS-1015, RS1020)
81 *	1310 4001 72131	Tone P.C.B. Assy (RS-1030)
82 *	1310 4001 72150	Power Amp P.C.B. Assy (RS-1015)
82-1	TR09023	IC PA401X (RS-1015,1020)
82 *	1310 4001 72151	Power Amp P.C.B. Assy (RS-1020)
82 *	1310 4001 72152	Power Amp P.C.B. Assy (RS-1030)
82-1	TR09024	IC PA501X (RS-1030)
83 *	1310 4001 72140	Power Supply P.C.B. Assy
84 *	1310 4001 72160	Dial Lamp P.C.B. Assy (RS-1015)
84 *	1310 4001 72161	Dial Lamp P.C.B. Assy (RS-1020, RS-1030)
C01,02	CK22351-3	Cap Ceramic 500pF 50V
C03,04		
C06	CK22362-14	Cap Ceramic 0.04 $\mu$ F 50V
C09	CK0248631	Cap Ceramic 1pF 50V
R01,02	RC20BF185J	Resistor 1.8Mohm 1/2W $\pm$ 5%
R03,04	RC20BF180J	Resistor 180ohm 1/2W $\pm$ 5% (RS-1015)
R03,04	RC20BF150J	Resistor 150ohm 1/2W $\pm$ 5% (RS-1020,RS-1030)
R05	RF25DC122J	Resistor 1.2kohm 1/4W $\pm$ 5%
R06	RF25DC332J	Resistor 3.3kohm 1/4W $\pm$ 5%

NOTE: \* Asterisk indicates not a service part

# POINT TO POINT WIRING DIAGRAM

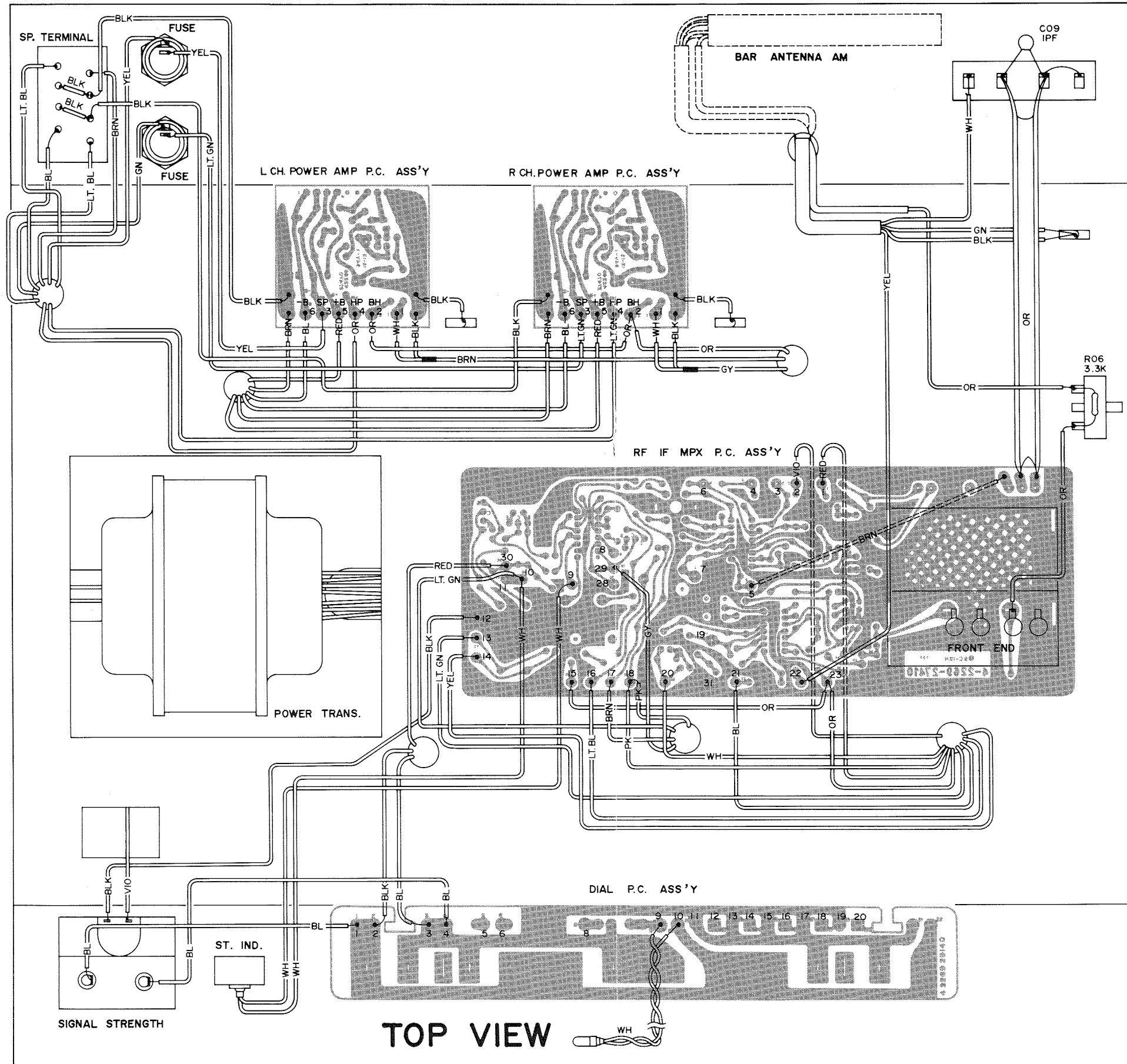

# POINT TO POINT WIRING DIAGRAM

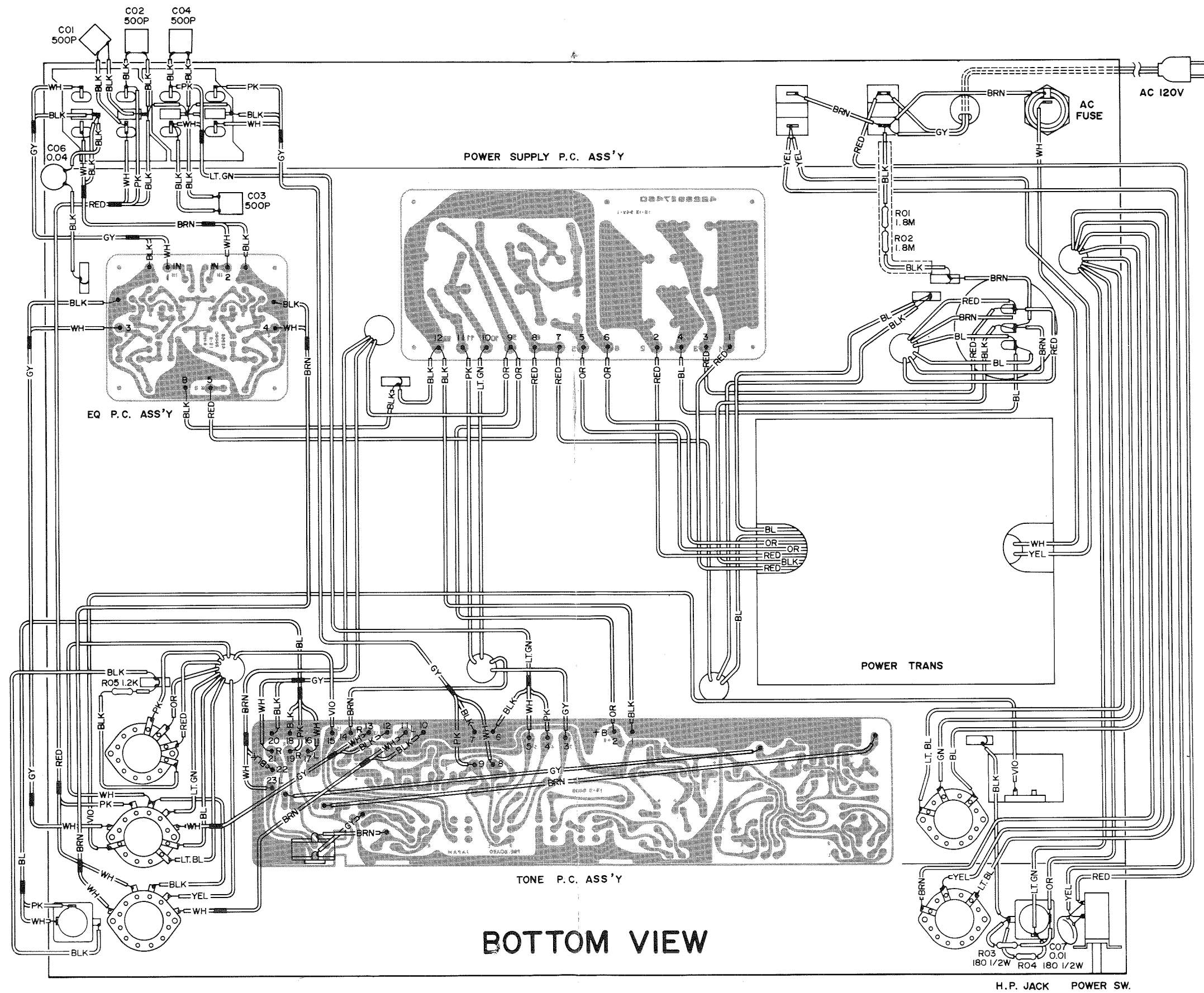

**BOTTOM VIEW**

# POINT TO POINT WIRING DIAGRAM

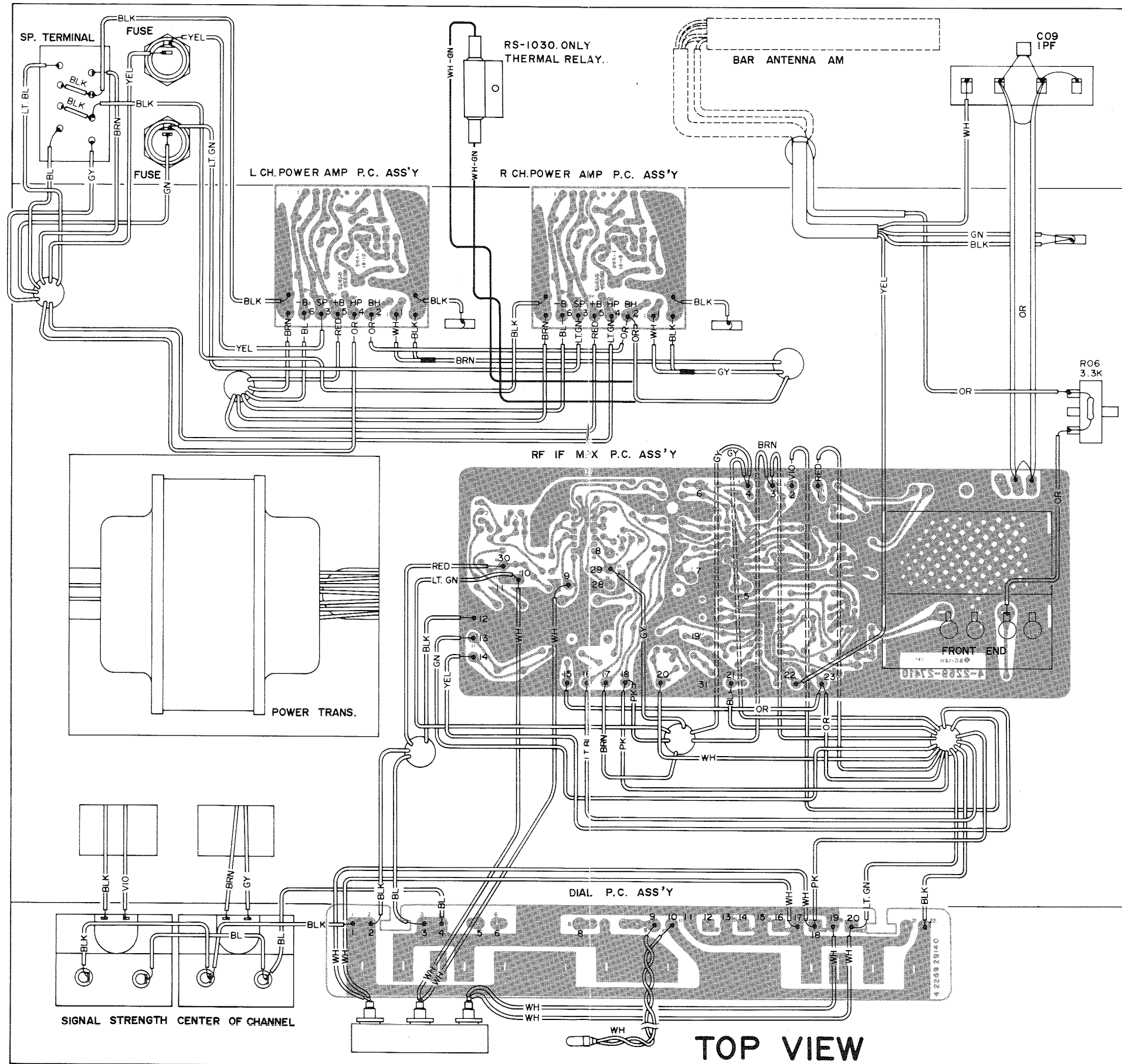

# POINT TO POINT WIRING DIAGRAM

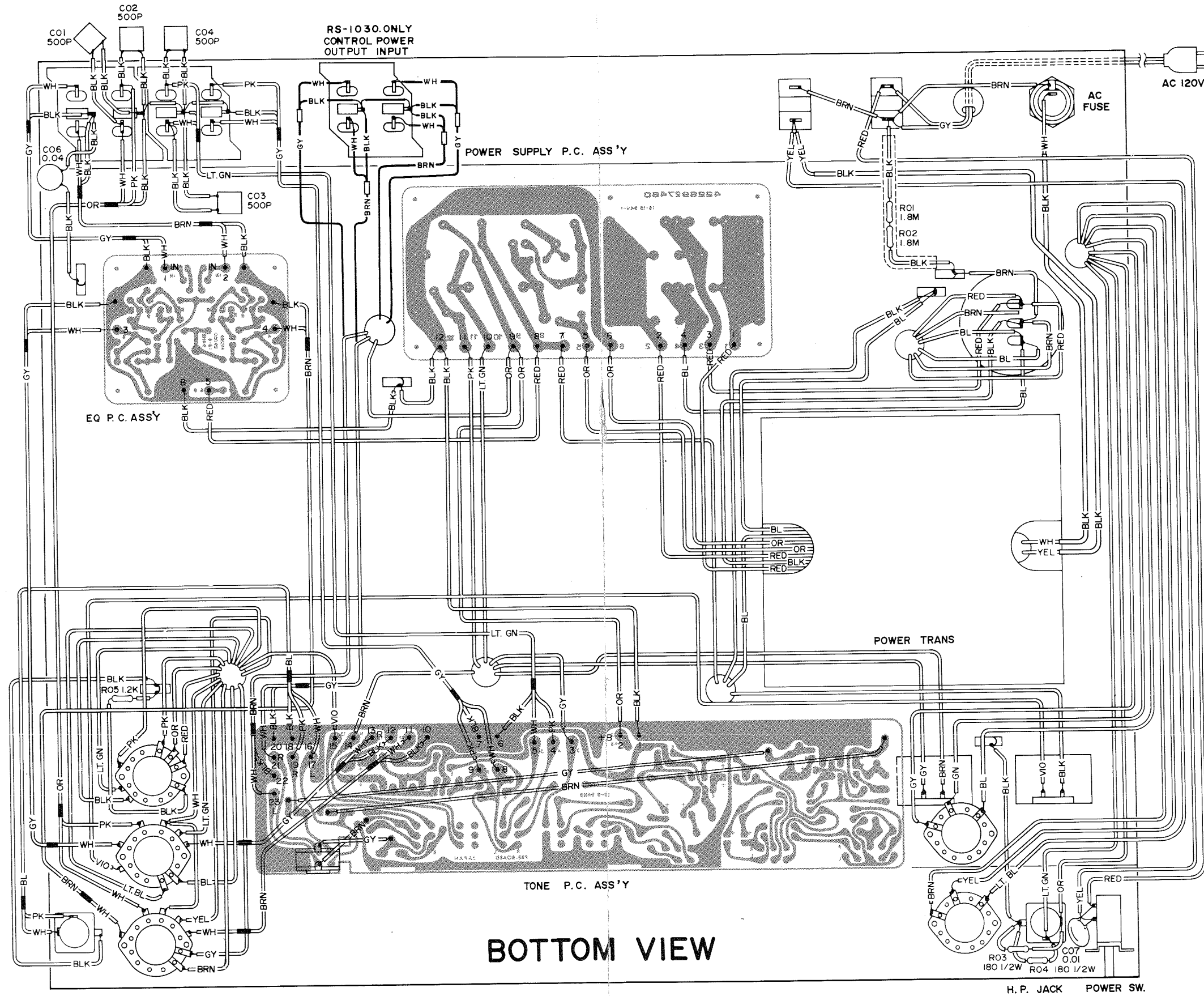

NOTES

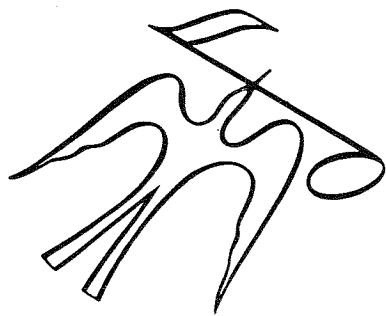

FISHER CORPORATION 11-40 45th ROAD • LONG ISLAND CITY • NEW YORK 11101