

**SERVICE MANUAL**



**FISHER**

**RS-1052L**

**Stereo Receiver**  
(EUROPE)



*The first name in high fidelity*

## TABLE OF CONTENTS

Specifications . . . . .	3
Recommended Test Equipment . . . . .	4
Disassembly Instructions. . . . .	5
Exploded View of Cabinet and Chassis Front Mounted Assemblies . . . . .	6
Exploded View of Chassis and Rear Mounted Assemblies . . . . .	7
Parts List . . . . .	8
Functional Block Diagram. . . . .	9
Dial Cord Stringing . . . . .	9
AM-FM Multiplex Alignment. . . . .	10
Alignment Wave Forms. . . . .	11
AM-FM RF/IF MPX Board Layout . . . . .	11
RF, IF MPX, P.C.B. Assy Parts List. . . . .	12
AM-FM RF/IF MPX P.C. Board . . . . .	13, 14
FM IF IC LA1230 Signal Flow. . . . .	13
FM MPX IC LA3350 Signal Flow . . . . .	13, 14
AM RF IF IC HA1151 Signal Flow. . . . .	14
LW/MW Converter P.C. Board . . . . .	15
EQ P.C. Board . . . . .	15
Booster P.C. Board . . . . .	16
Tone Control and Mode Selector P.C. Board. . . . .	15, 16
Power Amp P.C. Board. . . . .	17, 18
Power Supply P.C. Board . . . . .	17
Dial Lamp P.C. Board. . . . .	18
EQ, Tone, Booster, P.C.B. Assy Parts List . . . . .	19
Power Amp, Power Supply, Dial Lamp, P.C.B. Assy Parts List . . . . .	20
LW/MW Conv. P.C.B. Assy Parts List. . . . .	20
Power Amp IC STK-084 Schematic. . . . .	20
Point to Point Wiring Diagram Top View . . . . .	21, 22
Point to Point Wiring Diagram Bottom View. . . . .	23, 24
Schematic Diagram . . . . .	25, 26

## EXPLANATION OF PROTECTIVE CIRCUITS

\* For about two seconds after the power switch is turned on, the speakers remain silent because the power muting circuit operates during this time.

If this unit is operated with speakers of 4 ohm or less, or by being operated to drive two pairs of speakers of 8 ohm or less simultaneously, its power limiter will start to operate. If under these conditions the volume is raised to a high level the sound from the speakers may be distorted.

\* If the speaker terminals are short-circuited or the ventilation holes at the cabinet top are blocked during long periods of operation, the internal temperature may rise abnormally. At about 90°C, the thermal sensor (temperature detection) circuit becomes activated and will interrupt the signal. If the cause is removed and the internal temperature is back to normal, the unit automatically resets itself to restore normal operation.

**Nominal Specifications For Information Only.**

<b>RECEIVER</b>		<b>RS-1052L</b>	
<b>POWER AMPLIFIER SECTION</b>			
Continuous RMS sine wave power per channel within stated bandwidth at no more than stated distortion and with an 8 ohm load.		52W x 2	
Power Bandwidth		20Hz/20kHz	
Total Harmonic Distortion		0.2 %	
<b>PREAMPLIFIER SECTION</b>			
Input Sensitivity and Impedance At rated output, 8-ohms at 1kHz			
Phono		2mV/50k ohm	
Phono (max input capability)		110mV	
Auxiliary		150mV/100k ohm	
Tape Monitor		150mV/100k ohm	
Hum & Noise (below rated output)			
Phono		75 dB	
Auxiliary		90 dB	
Tape Monitor		90 dB	
Frequency Response			
Phono (RIAA EQUALIZED $\pm 2$ dB)		30Hz - 15kHz	
Auxiliary input $\pm 2$ dB		20Hz - 20kHz	
Tape Monitor input $\pm 2$ dB		20Hz - 20kHz	
Bass Control Range (at 100Hz)		$\pm 10$ dB	
Treble Control Range (at 10kHz)		$\pm 10$ dB	
Loudness Contour (at 30 dB volume attenuation)		+8 dB at 100Hz	
		+4 dB at 10kHz	
High Filter		-6 dB (4.5kHz)	
Separation (stereo) @ 1kHz		40 dB	
<b>FM TUNER SECTION</b>			
Usable Sensitivity	Mono	1.8 $\mu$ V/10.3 dBf	
	Stereo	4.6 $\mu$ V/18.5 dBf	
50 dB Quieting Sensitivity	Mono	2.8 $\mu$ V/14.2 dBf	
	Stereo	38 $\mu$ V/36.8 dBf	
Capture Ratio		1.0 dB	
Alt Channel Selectivity		68 dB	
Image Response Rejection		56 dB	
Spurious Response Rejection		85 dB	
AM Suppression		58 dB	
Signal-to-Noise Ratio (Mono & Stereo)		70/66 dB	
Total Harm. Distortion (Mono & Stereo) 1 kHz		0.15/0.20 %	
50 dB Quieting Sensitivity THD		0.4 %	
1 kHz Stereo		0.5 %	
Stereo Separation (1kHz/10kHz)		40/30 dB	
Sub-Carrier Suppression (19/38kHz)		60/70 dB	
<b>AM TUNER SECTION</b>			
Sensitivity	MW	300 $\mu$ V/m	
	LW	500 $\mu$ V/m	
Selectivity		43 dB	
Signal-to-Noise Ratio		48 dB	
Image Frequency Rejection		48 dB	
IF Rejection		45 dB	
<b>GENERAL SECTION</b>			
Power Requirements (50/60Hz)		AC 110V/220 V	
Power Consumption		500 VA	
Dimensions W x H x D		46.8 x 15.4 x 33.3 cm	
Weight		14 Kg	

*Because Fisher products are subject to continuous improvement, Fisher reserves the right to modify, change, or alter any design or specifications without notice and without incurring any obligation. Fisher reserves the right to make changes and improvements upon its products without any obligation to install such changes upon any of its products previously manufactured.*

## RECOMMENDED TEST EQUIPMENT

The following test equipment is recommended to completely test and align the Receiver:

- Line Voltage Isolation Transformer.
- AC DC Multimeter.
- Accurately Calibrated AC Voltmeter.
- Oscilloscope (Flat to 100 kHz Minimum)
- Low-Distortion Audio Sine-Wave Generator
- Harmonic Distortion Analyzer
- Two (2) Load Resistors, 8-ohms, 250 Watts (Minimum Rating)
- Low-Distortion AM-FM Signal Generator
- 10.7 MHz Sweep Generator
- Multiplex Generator
- 455 kHz Sweep Generator

## HARMONIC DISTORTION TEST

CAUTION: Limit the following tests to no more than ten minutes each. Use 8-ohm resistors with a minimum power rating of 250 watts when connecting a load across the SPEAKERS terminals.

### CONTROL SETTINGS:

Unplug the AC power cord and set the front panel controls as follows:

BASS, TREBLE, and BALANCE controls to center positions

POWER push button out (not depressed)

SPEAKERS switch to PHONES

FUNCTION switch to AUX

HIGH FILTER, MONO MODE, TAPE MONITOR and LOUDNESS CONTOUR out (not depressed)

VOLUME control to MINIMUM position

LEFT CHANNEL DRIVEN

### ONE CHANNEL DRIVEN:

- 1) Connect a low distortion audio generator to LEFT AUX IN jack. Set generator frequency to 1 kHz and output to minimum.
- 2) Connect an 8-ohm load resistor between SPEAKERS MAIN LEFT and COM terminals. Connect a Harmonic Distortion analyzer and an AC VTVM in parallel across the 8-ohm load.
- 3) Connect the AC power cord and set SPEAKERS switch to MAIN. Turn VOLUME control to MAX.
- 4) Increase generator output for RS-1052 52W RMS (20.3V across the 8-ohm load). Harmonic Distortion Analyzer should measure 0.2% distortion or less.
- 5) Repeat steps 1 through 4 for RIGHT CHANNEL.

### BOTH CHANNELS DRIVEN

Connect 8-ohm load resistors across LEFT and RIGHT MAIN SPEAKERS terminals. Depress "MONO MODE" pushbutton. Adjust generator output and "BALANCE" control for RS-1052: 52W at Left and Right Channels (RS-1052: 20.3V) across the 8-ohm loads.

Harmonic Distortion Analyzer should measure RS-1052: 0.2% distortion or less at each channel.

## DISASSEMBLY INSTRUCTIONS

### Removal Of Chassis From Cabinet

1. Remove 4 screws from left and right sides of cabinet.
2. Separate cabinet from chassis.
3. Remove 6 screws from bottom of cabinet. (Do Not Remove Leg From Bottom Of Cabinet).
4. Separate bottom of cabinet from chassis.

### Removal Of Front Panel Assembly

1. Remove all Knobs with the exception of push buttons.
2. Remove 4 screws from top of panel.
3. Remove nut from "Function" and "Speaker" switches located on Front Panel Assembly.
4. Separate Front Panel Assembly from chassis.

### Removal Of Meters

1. Unsolder leads from meter terminals.
2. Remove One screw and Meter Cover.
3. Grasp Meter firmly and pull back separating Meter from panel.

### Removal Of Slide Rail Pointer

1. Remove Metal Slide Pointer from Slide Rail Pointer.
2. Remove 2 screws from top of Slide Rail Pointer.

### Removal Of AM-FM Stereo Function Indicator Lamps

1. Grasp base of lamp with long-nosed Pliers and Carefully extract from grommet holder.
2. Unsolder AM-FM Indicator Lamp from P.C. Board.

### Removal And Replacement Of Dial Lamps

1. Remove Dial P.C. Board from Shelter Light with two flaps straight.
2. Grasp Dial Lamp and extract from lamp grommet holder.

Testing and troubleshooting any of the P.C. boards do not require removal since all component parts are top board mounted. For underneath board inspection purposes or when a defective component is to be unsoldered and replaced, the P.C. Board can be sufficiently turned over by only removing the hold down hardware. Where it necessitates complete removal of any individual board then proceed as follows.

### Removal Of AM-FM RF/IF/MPX Amp P.C. Board

1. Unscrew 2 screws from Drum. (Do Not Remove Dial String From Drum).
2. Remove 6 screws from P.C. Board.
3. Slide P.C. Board from plastic clip.
4. Unsolder connections and remove P.C. Board.

### Removal Of EQ-Amp P.C. Board

1. Unsolder wire wraps from terminals.
2. Remove 4 hold down screws.

### Removal Of Power Supply P.C. Board

1. Unsolder wire wraps from terminals.
2. Remove 5 hold down screws.
3. Slide P.C. Board from plastic clip.

### Removal Of Power Amp P.C. Board

1. Unsolder wire wraps from terminals.
2. Remove 4 screws holding Power IC (STK-084).
3. Remove screw holding posistor
4. Unscrew and remove plastic clip from P.C. Board.

### Removal Of Booster P.C. Board

1. Unsolder wire wraps from terminals.
2. Remove 2 hold down screws.

### Removal Of Tone Control Amp P.C. Board

1. Unsolder wire wraps from terminals.
2. Remove 2 screws from left and right sides of 4 push button switch.
3. Remove 4 nuts variable resistors.
4. Unscrew and remove 2 plastic clips from P.C. Board.

# EXPLODED VIEW OF CABINET AND CHASSIS FRONT MOUNTED ASSEMBLIES

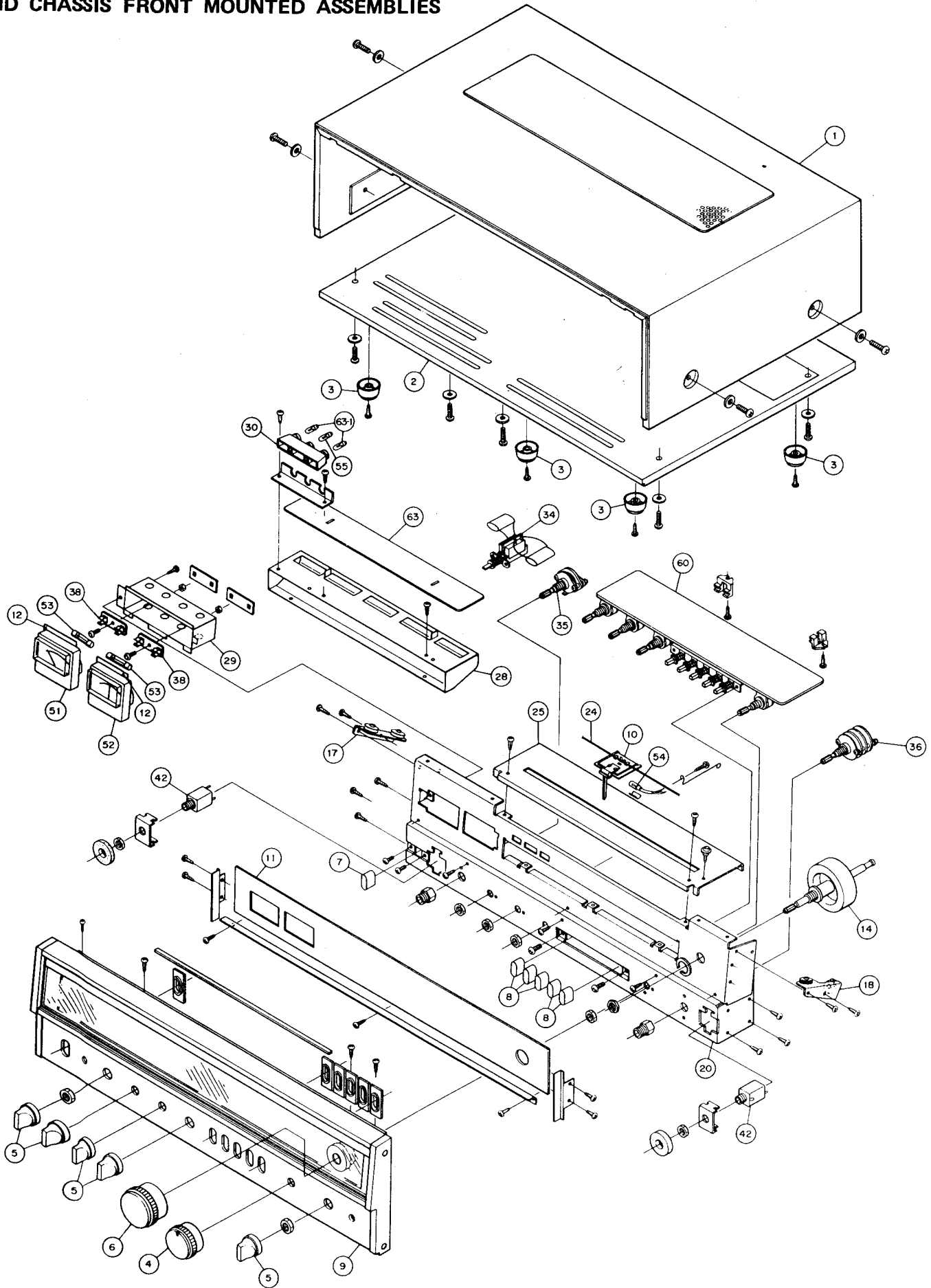

# EXPLODED VIEW OF CHASSIS AND REAR MOUNTED ASSEMBLIES

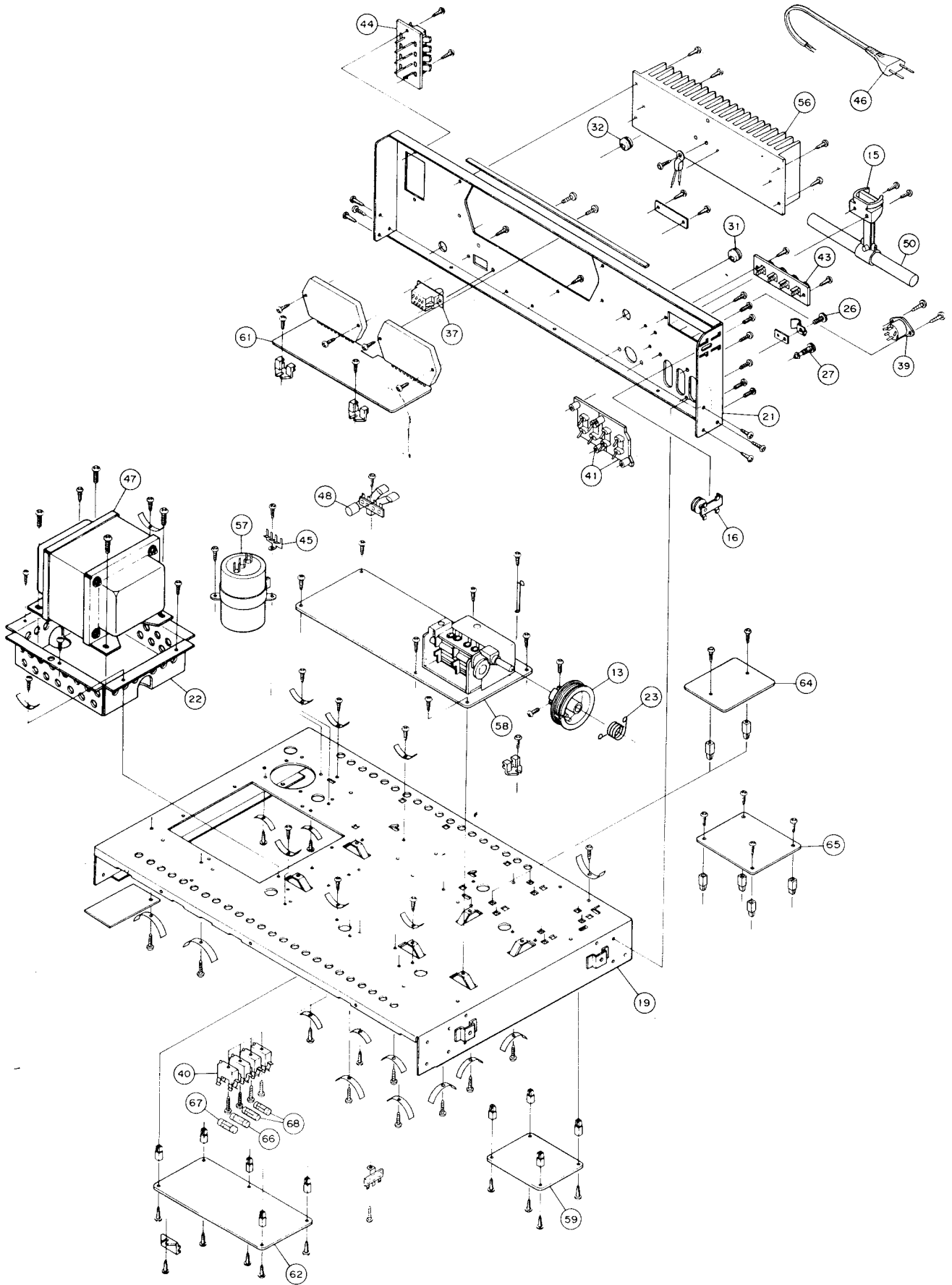

# PARTS LIST

## PACKING PARTS LIST

Ref. No.	Part Number	Description
	1316 1139 59211	Box Corrugate-EXP
	1316 2119 01362	Bag Polyethylene-EXP (Set)
	1316 2119 01470	Bag Polyethylene-EXP
	1316 3009 21510	Pad (Right)
	1316 3009 21520	Pad (Left)

## ACCESSORIES PARTS LIST

Ref. No.	Part Number	Description
	4 2449 20230	Antenna FM
	1316 2719 10801	Bag Fan
	1316 4119 59016	Explanatory Booklet (English & German)
	1316 4519 14700	Guarantee Certificate

## CABINET PARTS LIST

Ref. No.	Part Number	Description
1	1310 1101 08400	Cabinet Assy
2	1312 1105 17100	Plate Bottom
3	1312 1801 13200	Leg

## APPEARANCE PARTS LIST

Ref. No.	Part Number	Description
4	1310 1001 35400	Knob, Volume
5	1310 1001 35500	Knob, Controls
6	1310 1001 41400	Knob, Tuning
7	1312 1001 35600	Knob Power SW
8	1312 1001 35700	Knob Push SW
9	1310 1016 22610	Dress Panel Assy
10	1310 3011 16500	Dial Pointer Assy
11	1312 1201 28106	Dial Plate
12	1312 1406 12300	Plate Color

## CHASSIS PARTS LIST

Ref. No.	Part Number	Description
13	1310 3002 11300	Drum Assy Tuning Gang
14	1310 3003 19100	Tuning Shaft Assy
15	1310 3008 11901	Support, Antenna Assy
16	* 1310 3020 05800	Pulley Assy Rear
17	* 1310 3020 06900	Pulley Assy Left Front
18	* 1310 3020 07000	Pulley Assy Right Front
19	* 1312 3301 21800	Chassis
20	* 1312 3305 20001	Front Panel
21	* 1312 3306 22231	Rear Panel
22	* 1312 3617 15100	Metal Mount Trans
23	1312 4111 00400	Tension Spring
24	1312 4112 10200	Dial Cord
25	1312 4120 11700	Slide Rail Dial Pointer
26	1312 4201 12701	Screw, Coax Clamp
27	1312 4201 15400	Screw, Ground
28	* 1312 6110 23701	Housing, Dial Lamp P.C.B.
29	* 1312 6110 25800	Housing, Meter Lamp
30	1312 6111 19600	Housing, Stereo Beacon Lamp
31	1312 6111 14200	Bushing, AM ANT Lead
32	1312 6111 14200	Bushing, Line Cord

## ELECTRICAL PARTS LIST

Ref. No.	Part Number	Description
34	4 2319 23912	Switch, Power
35	4 2319 34021	Switch, Rotary, Speaker
36	4 2312 00790	Switch, Rotary, Function
37	4 2319 21531	Switch, Slide, Volt Select
38	4 2359 20160	Holder, Lamp
39	4 2359 20190	Socket DIN (TAPE)
40	4 2359 21021	Fuse Holder
41	4 2359 22710	Rear Accessory Jacks
42	4 2359 22730	Jack, Phones/Record Out
43	4 2379 21460	Terminal, Antenna Connector
44	4 2379 21560	Terminal, Speakers Connector
45	4 2379 21840	Terminal
46 *	4 2439 20521	Line Cord
47	4 2519 24051	Power Transformer (110 - 220V)
48	4 2659 20190	Choke Coil (AM Out)
50	4 2579 25110	AM Antenna (LW/MW)
51	4 5119 20592	Meter, Signal Strength
52	4 5119 20602	Meter, Center of Channel
53	4 6129 20280	Pilot Lamp (Meter Lamp)
54	4 6129 20592	Small Lamp Indicator (Pointer)
55	4 6129 20726	Pilot Lamp (Stereo Indicator)
56	1312 6201 21801	Heat Sink
C01,02	C1HCDK471SL	Cap. Ceramic 470pF 50V ±10%
C03,04	C2EHRM103A	Cap. Poly Paper 0.01 μF 250V ±20%
C05	C1HFRM683A	Cap. Mylar 0.068 μF 50V ±20%
C06	C1HYDZ473A	Cap. Ceramic 0.047 μF 50V +80,-20%
C07	C1HFRK273A	Cap. Mylar 0.027 μF 50V ±10%
57(C08)	4 2239 21150	Cap. Electrolytic 6800 μF x2 50V
C09	C1HCDC010SL	Cap. Ceramic 1pF 50V ±0.25%
R01,02	R2EDPJ274A	Resistor Carbon 270k 1/4W ±5%
R03,04	R3AXPK121A	Resistor Oxide Metal Film 120 1W ±10%
R05	R2EDPJ122A	Resistor Carbon 1.2k 1/4W ±5%
R06	R2HCPK332A	Resistor Solid 3.3k 1/2W ±10%
R07	R2EDPJ272A	Resistor Carbon 2.7k 1/4W ±5%
58 *	1310 4001 93100	RF IF MPX PCB Assy
59 *	1310 4001 72120	EQ PCB Assy
60 *	1310 4001 72133	Tone PCB Assy
61 *	1310 4001 79305	Power Amp PCB Assy
62 *	1310 4001 93201	Power Supply PCB Assy
63 *	1310 4001 72161	Dial Lamp PCB Assy
64 *	1310 4001 79500	Booster PCB Assy
65 *	1310 4001 75303	LW/MW Conv. PCB Assy
66	4 2349 20380	Fuse 1A Slow Blow
67	4 2349 20590	Fuse 4A Slow Blow
68	4 2349 21570	Fuse 6.3A 250V Time Lag

NOTE: \* Asterisk indicates not service part.



# FUNCTIONAL BLOCK DIAGRAM

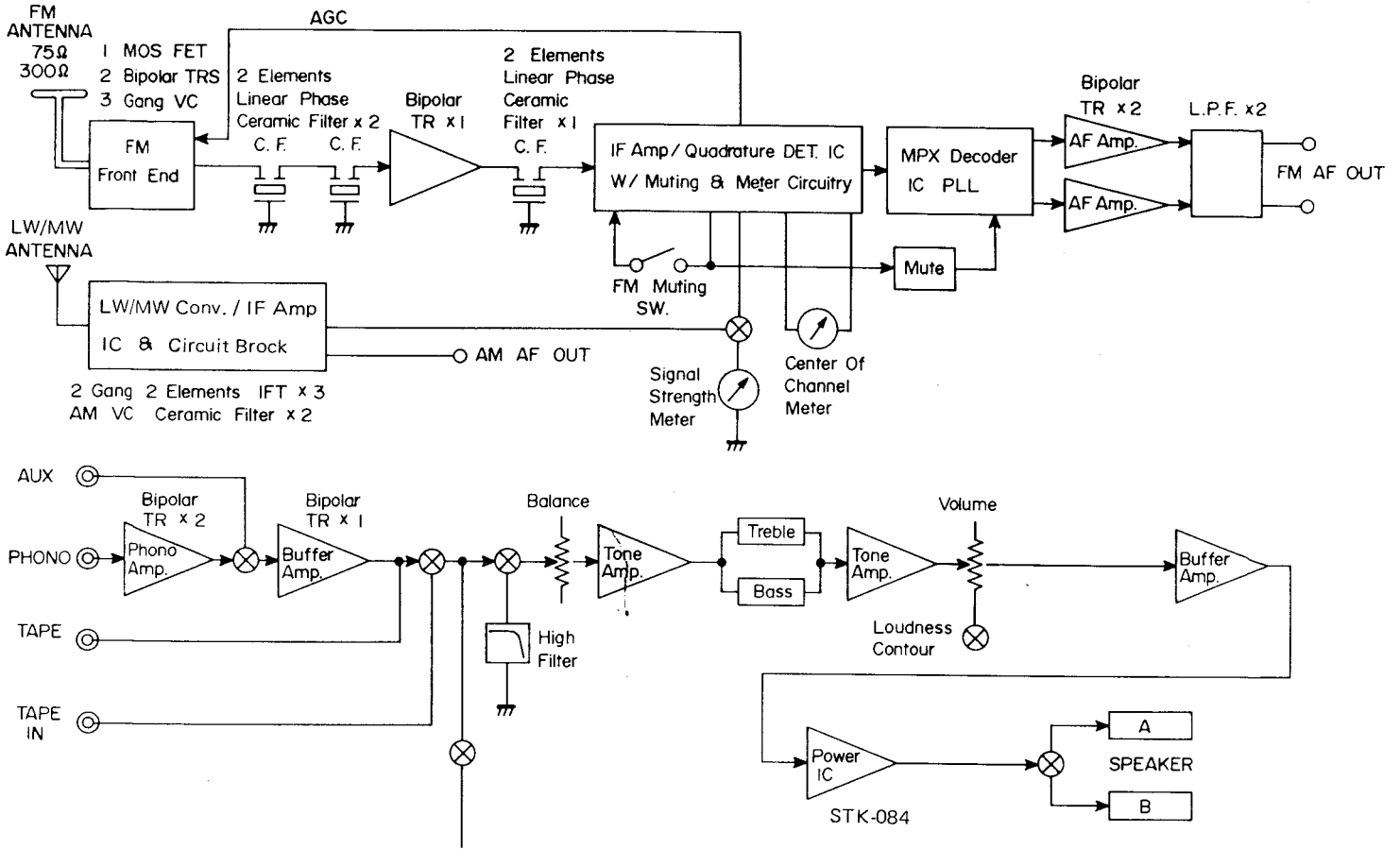

# DIAL CORD STRINGING

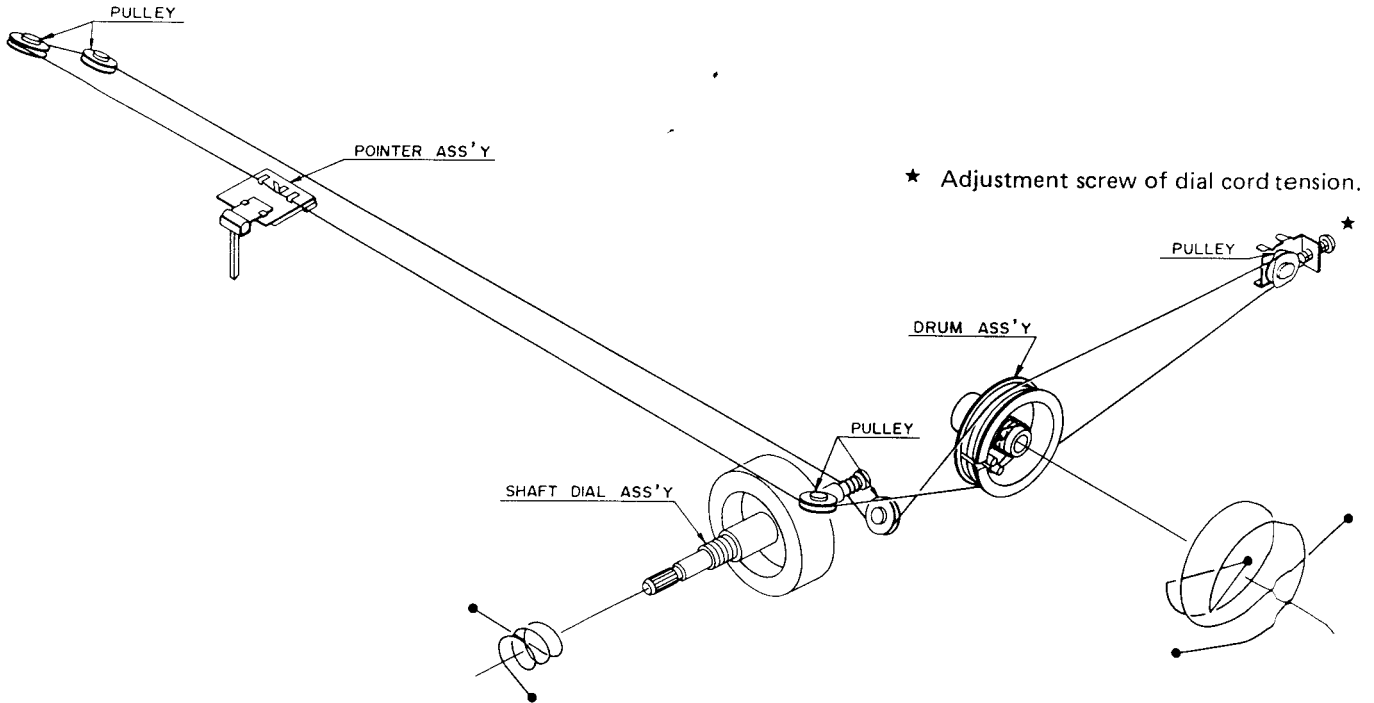

# AM-FM MULTIPLEX ALIGNMENT

## AM ALIGNMENT

For Alignment: Maintain generator output as low as possible for suitable indication.

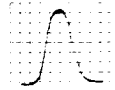
Step	Adjusting circuit	Connection		Position of Tuning dial	Adjustment	V.T.V.M. Oscilloscope
		Input	Output			
1	IF	Connect 455 kHz sweep generator to VC4.	Connect Oscilloscope to Test Point TP 19.	Near max. capacity of VC at position of on interference	AM 1st 9-21310 AM DET 9-21291	
2	MW(RF)	Connect AM generator to EXT AM antenna and GND terminals. Set to 600 kHz. Modulate with 30%, 400 Hz.	Connect Oscilloscope and AC. V.T.V.M. to speaker terminal.	600 kHz	AM BAR ANT 9-25110 MW OSC 9-20851	Max.
3		Change frequency to 1400 kHz.		1400 kHz	TC 01, 03	
4	LW(RF)	Change frequency to 160 kHz.		160 kHz	LW OSC 9-20860	Max.
5		Change frequency to 350 kHz.	350 kHz	TC 02, 04		
6	Repeat adjustments.					

- Variable capacitor completely closed
- Set the dial pointer to very left line dial scale.
- Connect sweep generator, SG, V.T.V.M. and oscilloscope.
- Function switch to "MW" or "LW"
- Use a screwdriver with plastic grip for all adjustments.

## FM ALIGNMENT

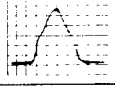
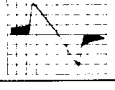
Step	Adjusting circuit	Connection		Position of Tuning dial	Adjustment	V.T.V.M. Oscilloscope
		Input	Output			
1	IF	Connect sweep 10.7 MHz generator to test point VC 2 through 0.01 $\mu$ F.	Connect Oscilloscope to Test Point TP 7.	Near max. capacity of VC. at position of on interference	IFT in FRONT END	
2	Quadrature Detector		Connect Oscilloscope to Test Point TP 6.		FM DET 9-21320	
3	RF	Connect FM RF generator through two 120-ohm resistors to FM antenna screw terminals. Set generator to 90 MHz, modulate with 400 Hz to provide $\pm 75$ kHz deviation. Set generator output attenuator as low as possible.	Connect V.T.V.M. to Speaker terminal.	90 MHz	LA LR	Max.
4		Change generator setting to 106 MHz.		106 MHz	TCA, TCR	Max.
5	Repeat adjustments.					

- Variable capacitor completely closed
- Set the dial pointer to very left line of dial scale.
- Connect sweep generator, FM, SG, V.T.V.M. and oscilloscope. FM ANT input impedance is 75 ohm.
- Function switch to "FM"
- Use a screwdriver with plastic grip for all adjustments.

## FM MPX ALIGNMENT

Step	Adjusting circuit	Connection		Position of Tuning dial	Adjustment	
		Input	Output			
1	PLL IC FO (19 kHz) Adjustment	None	Connect Frequency counter or synchroscope to TP 8.	Near max. capacity of VC. at position of on interference	Adjust VR01 (5k-B) so that frequency counter or synchroscope indicate 19 kHz.	
2	FM STEREO Signal Separation	As above Steps 3,4 except modulation Modulate LEFT Channel $\pm 67.5$ kHz -400 Hz audio and $\pm 7.5$ kHz -19 kHz pilot carrier. As above except modulate RIGHT Channel.	Connect V.T.V.M. to output terminal (R Channel)		VR02, (1k-B)	V.T.V.M. Min.
			Connect V.T.V.M. to output terminal (L Channel).			
3	Repeat steps 1,2. Set at position with max. channel separation.					

- Variable capacitor completely closed
- Connect FM stereo SG and V.T.V.M.
- Function switch to "FM"
- Use a screwdriver with plastic grip for all adjustments.

# ALIGNMENT WAVE FORMS

WITH OSCILLOSCOPE TIME BASE SETTINGS

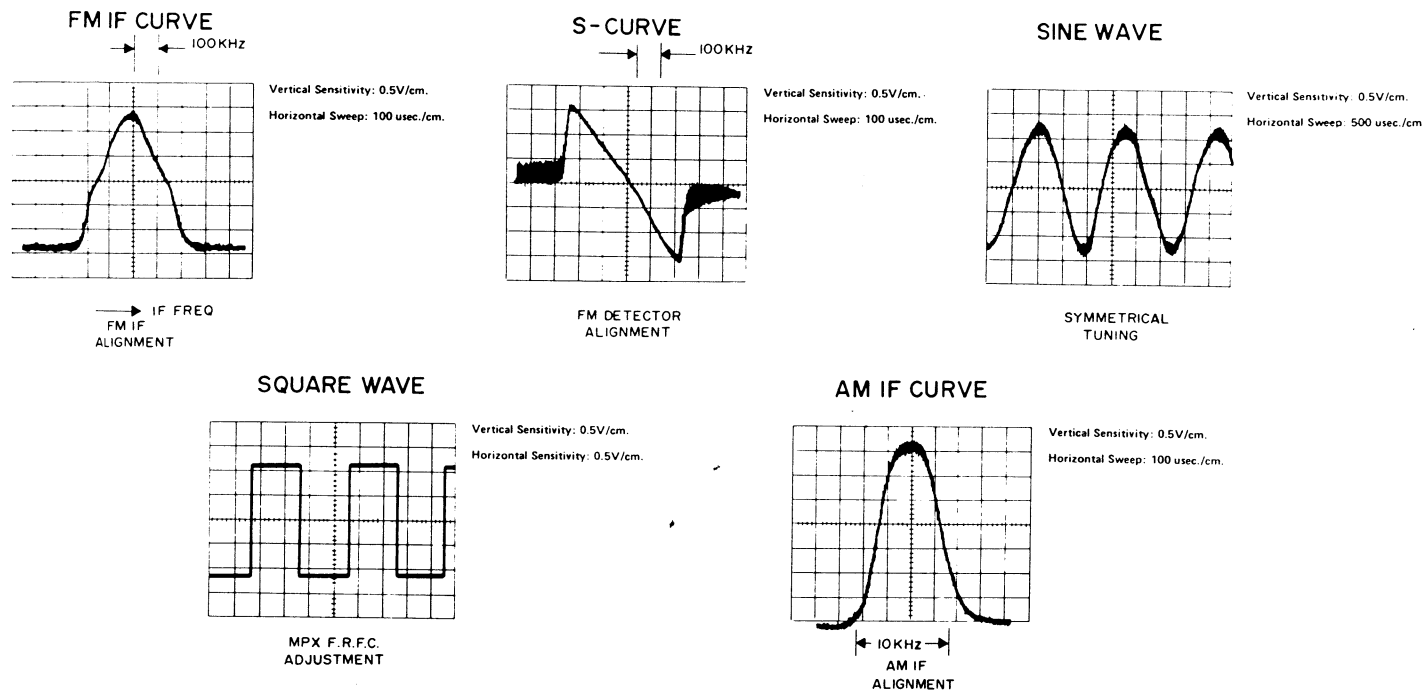

## AM-FM RF/IF MPX BOARD LAYOUT

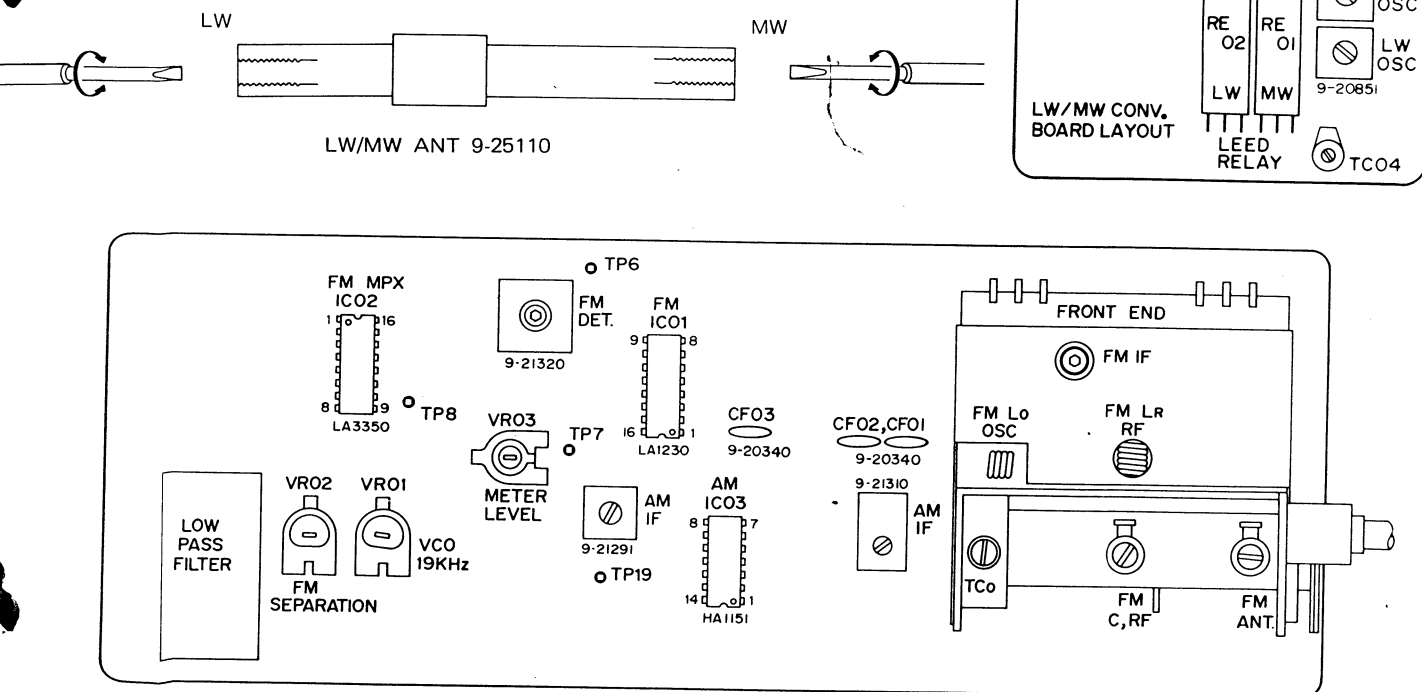

# PARTS LIST

### RF. IF. MPX PCB Assy 1310 4001 93100

Ref. No.	Part Number	Description
	4 1259 20370	Front End
VR01	4 2229 22842	VR 5k (19kHz)
VR02	4 2229 24210	VR 1k (Separation)
VR03	4 2229 25400	VR 50k Meter Level
	4 2279 20340	Ceramic Filter
	4 2279 20320	Low Pass Filter 19kHz
	4 2569 21291	IF Trans AM (Black)
	4 2569 21310	IF Trans AM (Red)
	4 2569 21320	IF Trans FM (Quadrature)
L01	4 2539 20170	Choke Coil
L02	4 2539 20370	10 $\mu$ H $\pm$ 10%
L03	4 2539 20380	18 $\mu$ F $\pm$ 5%

### CAPACITORS

C01,02	C1HBDM473W	Semicon 0.047 $\mu$ F 50V $\pm$ 20%
C03		
C06,07	C1HYSZ473A	Ceramic 0.047 $\mu$ F 50V +80,-20%
C08	C1CUEX105A	Sint. Alu. 1 $\mu$ F 16V +40,-20%
C09	C1CRE-475A	Electrolytic 4.7 $\mu$ F 16V $\pm$ 10%
C10	C1HCSK331SL	Ceramic 330pF 50V $\pm$ 10%
C11	C1CUEX474A	Sint. Alu. 0.47 $\mu$ F 16V +40,-20%
C12,13	C1CUEX224A	Sint. Alu. 0.22 $\mu$ F 16V +40,-20%
C14	C1CRE-105A	Electrolytic 1 $\mu$ F 16V
C15	C1HYSZ473A	Ceramic 0.047 $\mu$ F 50V +80,-20%
C16	C1CRE-227A	Electrolytic 220 $\mu$ F 16V
C17	C1VRE-106A	Electrolytic 10 $\mu$ F 35V
C18,19	C1CUEX224A	Sint. Alu. 0.22 $\mu$ F 16V +40,-20%
C20	C1CUEX474A	Sint. Alu. 0.47 $\mu$ F 16V +40,-20%
C21	C1HFRM473A	Mylar 0.047 $\mu$ F 50V $\pm$ 20%
C22	C1HSEJ152A	Styrol 1500pF 50V $\pm$ 5%
C23,24	C1HFRK153A	Mylar 0.015 $\mu$ F 50V $\pm$ 10%
C25,26	C1CUEX475A	Sint. Alu. 4.7 $\mu$ F 16V +40,-20%
C27,28	C1VTRM475A	Tantal 4.7 $\mu$ F 35V $\pm$ 20%
C29	C1CRE-107A	Electrolytic 100 $\mu$ F 16V
C31	C1CRE-106A	Electrolytic 10 $\mu$ F 16V
C32,33	C1HFRM103A	Mylar 0.01 $\mu$ F 50V $\pm$ 20%
C36	C1HFRM103A	Mylar 0.01 $\mu$ F 50V $\pm$ 20%
C37	C1HYSX473A	Ceramic 0.047 $\mu$ F 50V +80,-20%
C38, 39	C1HFRM103A	Mylar 0.01 $\mu$ F 50V $\pm$ 20%
C40	C1HFRM102A	Mylar 0.001 $\mu$ F 50V $\pm$ 20%
C41	C1CUEX105A	Sint. Alu. 1 $\mu$ F 16V +40,-20%
C42	C1CRE-475A	Electrolytic 4.7 $\mu$ F 16V
C43	C1HFRM273A	Mylar 0.027 $\mu$ F 50V $\pm$ 20%
C44	C1HRE-225AL	Electrolytic 2.2 $\mu$ F 50V
C45	C1HCSK470SL	Ceramic 47pF 50V $\pm$ 10%
C46	C1CRE-106A	Electrolytic 10 $\mu$ F 16V
C47, 48	C1HYSX223A	Ceramic 0.022 $\mu$ F 50V +80,-20%
C49	C1HCSJ150SL	Ceramic 15pF 50V $\pm$ 5%

### Ref. No. Part Number Description

Ref. No.	Part Number	Description
	<b>SEMICONDUCTORS</b>	
D01,02	2055 9040 44210	Diode DS-442
03,04		
IC01	2065 0151 23013	IC LA1230
IC02	2065 0743 35012	IC LA3350
IC03	1KK-HA1151	IC HA1151
Q01	2035 5100 53650	TR 2SC536E
Q02,03	2035 5151 57079	TR 2SC1570 LG
Q04	2035 5500 93040	TR 2SC930D

### RESISTORS

R01	R2EDSJ331A	Carbon 330	1/4W $\pm$ 5%
R02	R2EDSJ104A	Carbon 100k	1/4W $\pm$ 5%
R03	R2EDSJ562A	Carbon 5.6k	1/4W $\pm$ 5%
R04	R2EDSJ222A	Carbon 2.2k	1/4W $\pm$ 5%
R05	R2EDSJ101A	Carbon 100	1/4W $\pm$ 5%
R06	R2EDSJ563A	Carbon 56k	1/4W $\pm$ 5%
R07	R2EDSJ222A	Carbon 2.2k	1/4W $\pm$ 5%
R08	R2EDSJ473A	Carbon 47k	1/4W $\pm$ 5%
R09	R2EDSJ154A	Carbon 150k	1/4W $\pm$ 5%
R10	R2EDSJ332A	Carbon 3.3k	1/4W $\pm$ 5%
R11	R2EDSJ822A	Carbon 8.2k	1/4W $\pm$ 5%
R12	R2EDSJ222A	Carbon 2.2k	1/4W $\pm$ 5%
R13, 14	R2EDSJ332A	Carbon 3.3k	1/4W $\pm$ 5%
R15, 16	R2EDSJ474A	Carbon 470k	1/4W $\pm$ 5%
R17, 18	R2EDSJ333A	Carbon 33k	1/4W $\pm$ 5%
R19, 20	R2EDSJ392A	Carbon 3.9k	1/4W $\pm$ 5%
R21, 22	R2EDSJ331A	Carbon 330	1/4W $\pm$ 5%
R23, 24	R2EDSJ332A	Carbon 3.3k	1/4W $\pm$ 5%
R25	R2EDSJ101A	Carbon 100	1/4W $\pm$ 5%
R26	R2EDSJ103A	Carbon 10k	1/4W $\pm$ 5%
R27	R2EDSJ101A	Carbon 100	1/4W $\pm$ 5%
R28	R2EDSJ470A	Carbon 47	1/4W $\pm$ 5%
R29	R2EDSJ151A	Carbon 150	1/4W $\pm$ 5%
R30	R2EDSJ392A	Carbon 3.9k	1/4W $\pm$ 5%
R31	R2EDSJ151A	Carbon 150	1/4W $\pm$ 5%
R32, 33	R2EDSJ103A	Carbon 10k	1/4W $\pm$ 5%
R34	R2EDSJ272A	Carbon 2.7k	1/4W $\pm$ 5%
R35	R2EDSJ332A	Carbon 3.3k	1/4W $\pm$ 5%
R36	R2EDSJ472A	Carbon 4.7k	1/4W $\pm$ 5%
R37	R2EDSJ103A	Carbon 10k	1/4W $\pm$ 5%
R38	R2EDSJ224A	Carbon 220k	1/4W $\pm$ 5%
R39	R2EDSJ391A	Carbon 390	1/4W $\pm$ 5%
R40	R2EDUJ224A	Carbon 220k	1/4W $\pm$ 5%
R41	R2EDSJ222A	Carbon 2.2k	1/4W $\pm$ 5%
R42	R2EDSJ562A	Carbon 5.6k	1/4W $\pm$ 5%
R43	R2EDSJ101A	Carbon 100	1/4W $\pm$ 5%
R44	R2EDSJ222A	Carbon 2.2k	1/4W $\pm$ 5%
R45	R2EDSJ471A	Carbon 470	1/4W $\pm$ 5%
R46	R2EDSJ182A	Carbon 1.8k	1/4W $\pm$ 5%
R47	R2EDSJ391A	Carbon 390	1/4W $\pm$ 5%
R48	R2EDSJ473A	Carbon 47k	1/4W $\pm$ 5%
R51	R2EDPJ102A	Carbon 1k	1/4W $\pm$ 5%

# AM-FM RF/IF MPX P.C.BOARD

IC TOP VIEW

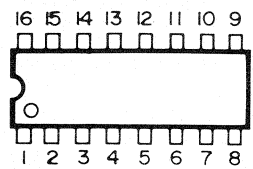

LA1230  
LA3350

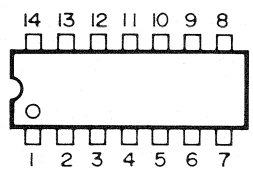

HA1151

TRANSISTOR FRONT VIEW

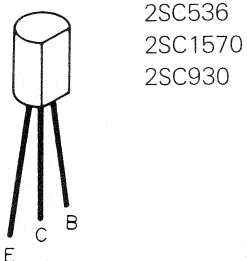

2SC536  
2SC1570  
2SC930

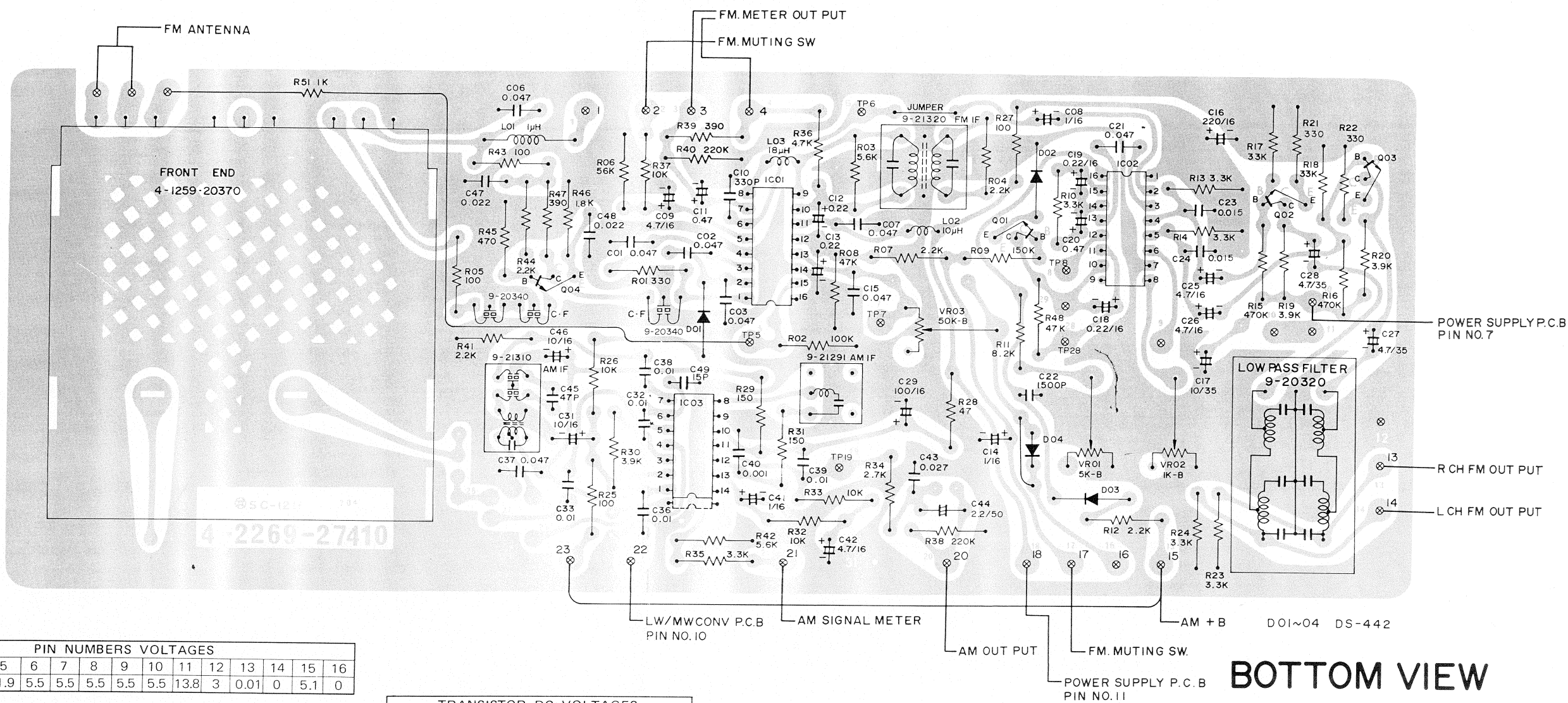

PIN NUMBERS		VOLTAGES															
IC	IC No.	1	2	3	4	5	6	7	8	9	10	11	12	13	14	15	16
I001	LA1230	2.9	2.9	2.9	0	1.9	5.5	5.5	5.5	5.5	13.8	3	0.01	0	5.1	0	

I001 LA1230

PIN NUMBERS		VOLTAGES															
IC	IC No.	1	2	3	4	5	6	7	8	9	10	11	12	13	14	15	16
I002	LA3350	12.6	2.7	4.8	10.5	10.4	13.4	0	0.4		0.6	2	2.4	1.9	2	2	2.7

I002 LA3350

PIN NUMBERS		VOLTAGES															
IC	IC No.	1	2	3	4	5	6	7	8	9	10	11	12	13	14	15	16
I003	HA1151	0.97	12.7	10.9	12.7	3.5	1.24	2.1	8.5	0	13.3	1.6	0.7	1.4	0		

I003 HA1151

TRANSISTOR DC VOLTAGES				
SYMBOL No.	DEVICE	B	C	E
Q01	2SC536E	1.1	0.6	0.5
Q02	2SC1570LH	2	16.5	1.4
Q03	2SC1570LH	2	16.5	1.4
Q04	2SC930D	2.2	12.8	1.6

FM IF IC LA1230 SIGNAL FLOW

FM MPX IC LA3350 SIGNAL FLOW

AM RF IF IC HA1151 SIGNAL FLOW

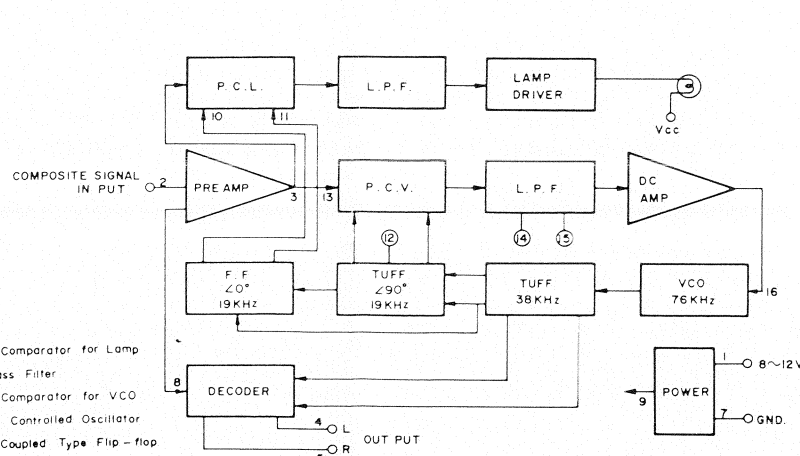
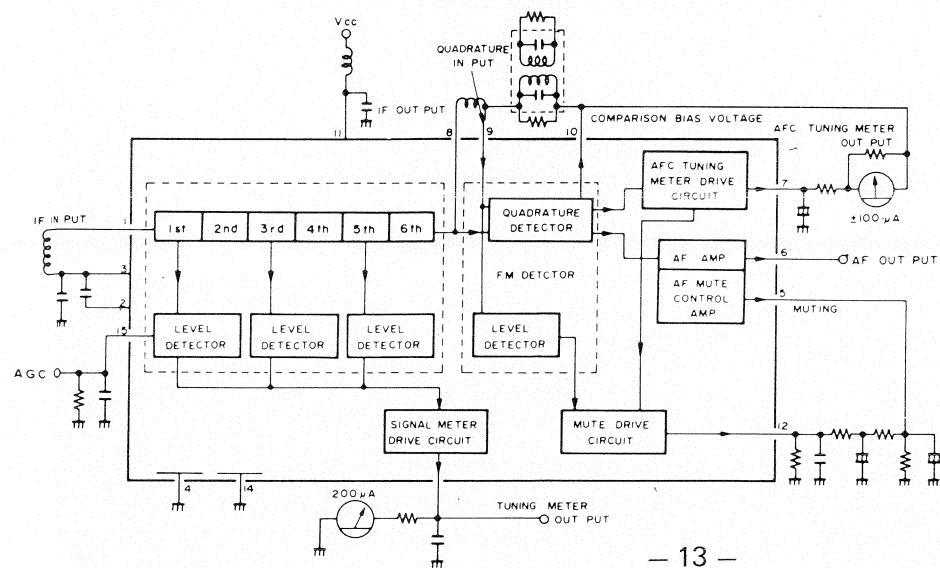

P.C.L.: Phase Comparator for Lamp  
L.P.F.: Low Pass Filter  
P.C.V.: Phase Comparator for VCO  
VCO: Voltage Controlled Oscillator  
TUFF: Direct Coupled Type Flip-flop

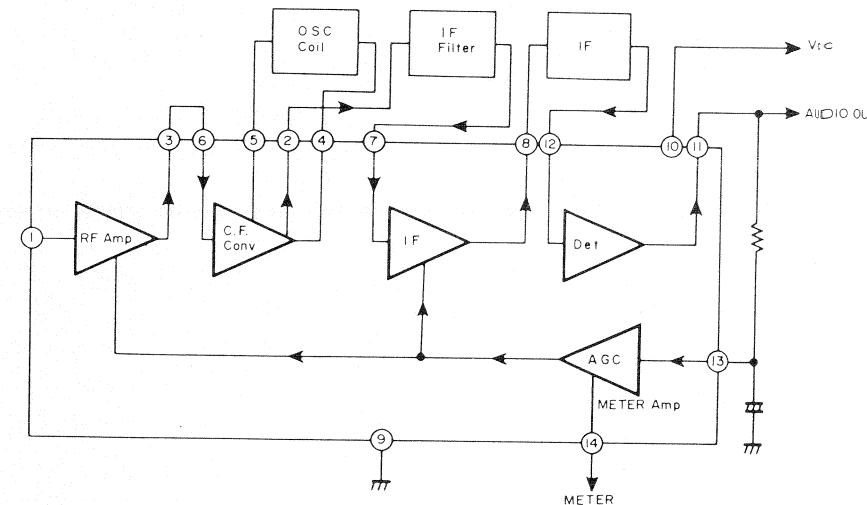

# LW/MW CONVERTER P.C.BOARD

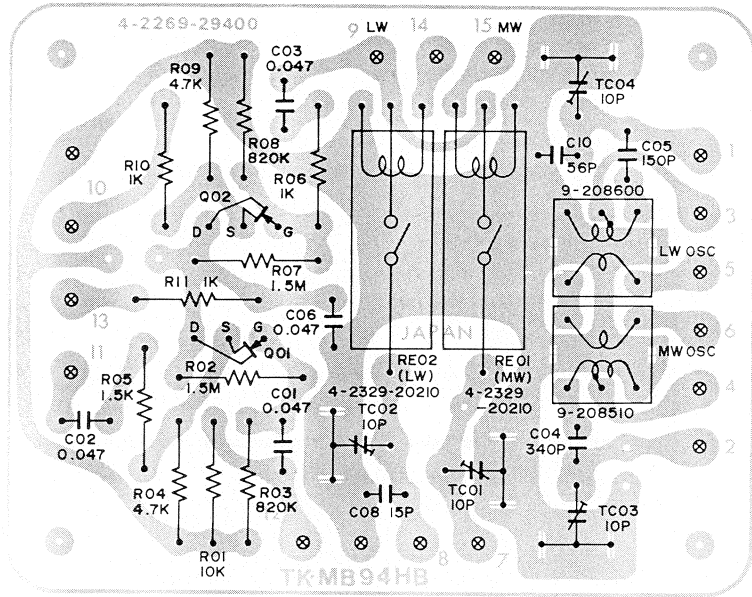

Q01, 02 2SK41 (F)

FET DC VOLTAGES				
SYMBOL No.	DEVICE	D	S	G
Q01	2SK41	11.6	5.4	3.9
Q02	2SK41	11.6	5.1	3.8

# EQ P.C.BOARD

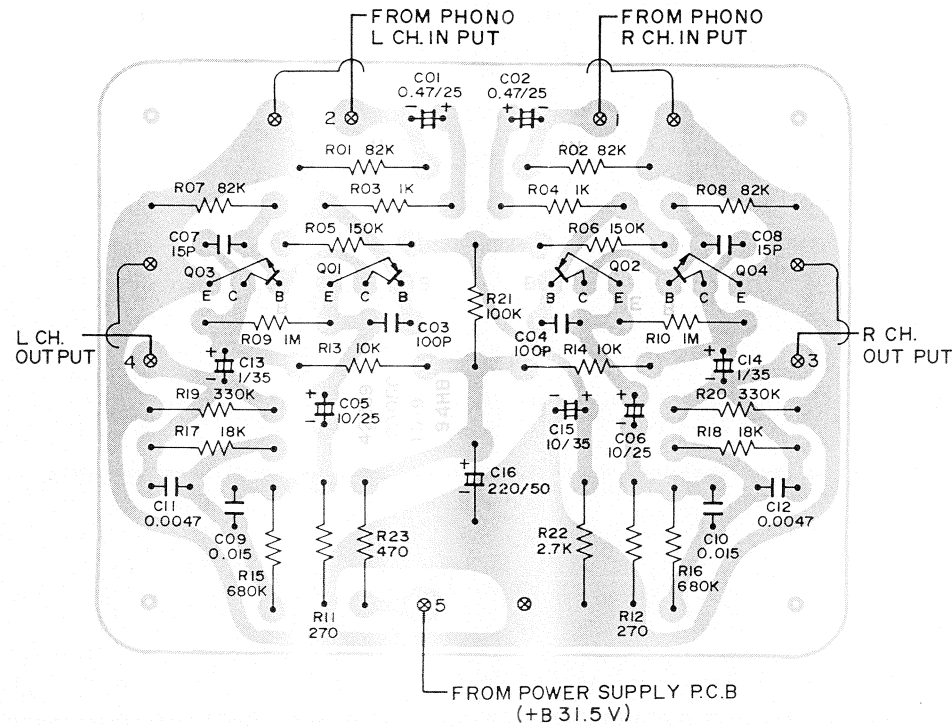

TRANSISTOR DC VOLTAGES				
SYMBOL No.	DEVICE	B	C	E
Q01, 02	2SA763E	0.77	0.59	1.3
Q03, 04	2SC1570LH	0.59	11	0

# BOOSTOR P.C.BOARD

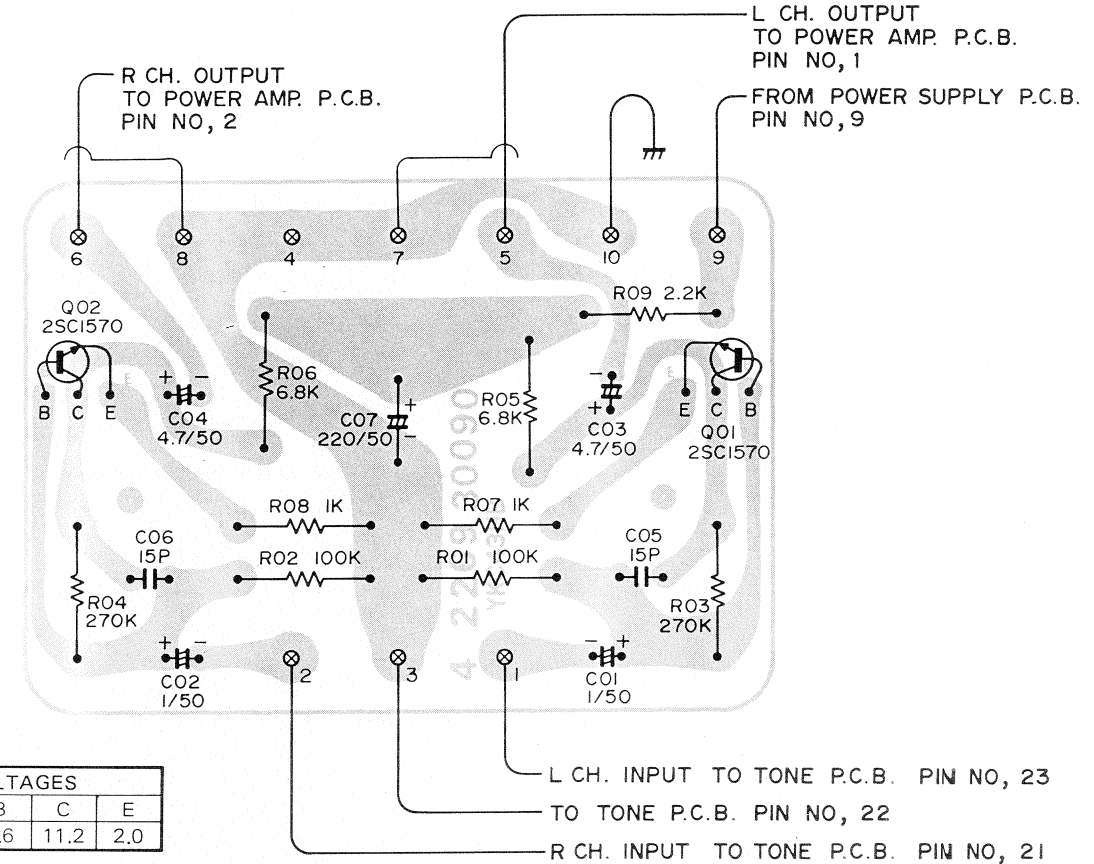

TRANSISTOR DC VOLTAGES				
SYMBOL No.	DEVICE	B	C	E
Q01, 02	2SC1570	2.6	11.2	2.0

# TONE CONTROL AND MODE SELECTOR P.C.BOARD

IFT FRONT VIEW      TRANSISTOR FRONT VIEW



2SK41



2SA763  
2SC1570

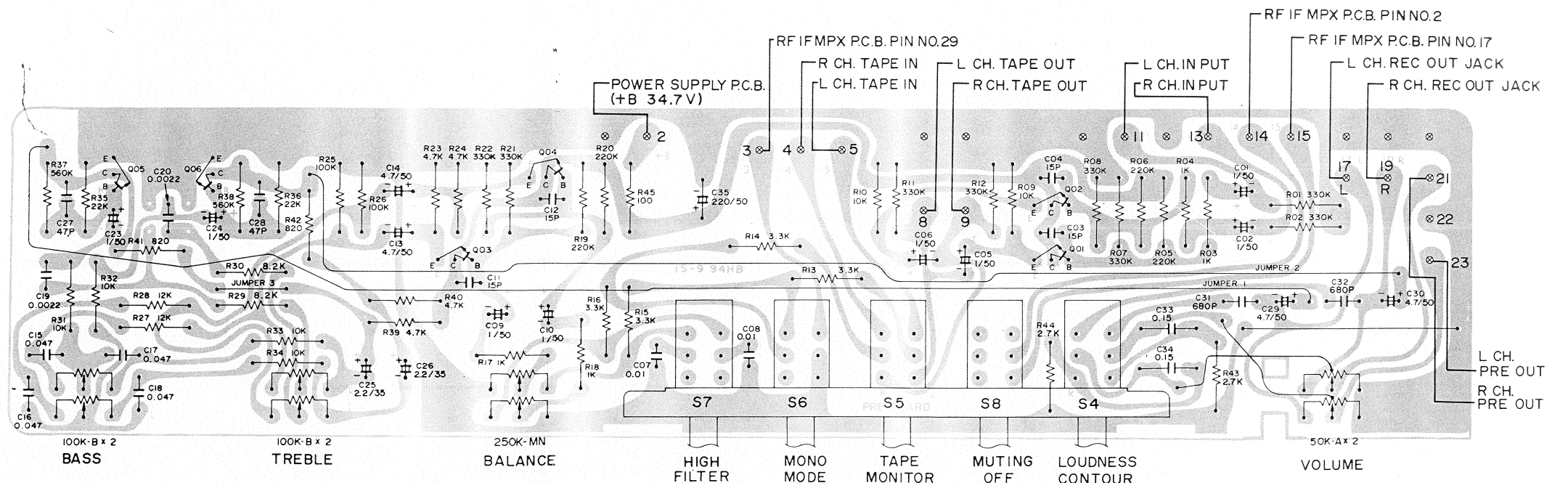

TRANSISTOR DC VOLTAGES				
SYMBOL No.	DEVICE	B	C	E
Q01, 02	2SC1570LH	18.9	33.0	18.6
Q03, 04	2SC1570LH	18.5	33.0	18.1
Q05, 06	2SC1570LH	0.6	19.0	0

# BOTTOM VIEW

# POWER AMP P.C.BOARD

## POWER AMP IC STK-084 SCHEMATIC

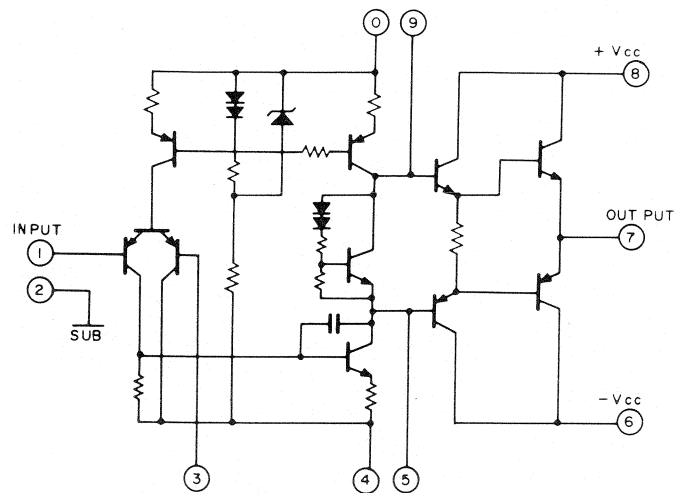

IC01, 02  
STK-084

PIN NUMBERS VOLTAGES					
4	5	6	8	9	10
-42.2	-1.3	-43.3	43.3	1.2	42.0

## POWER AMP IC ( R CH. )

## POWER AMP IC ( L CH. )

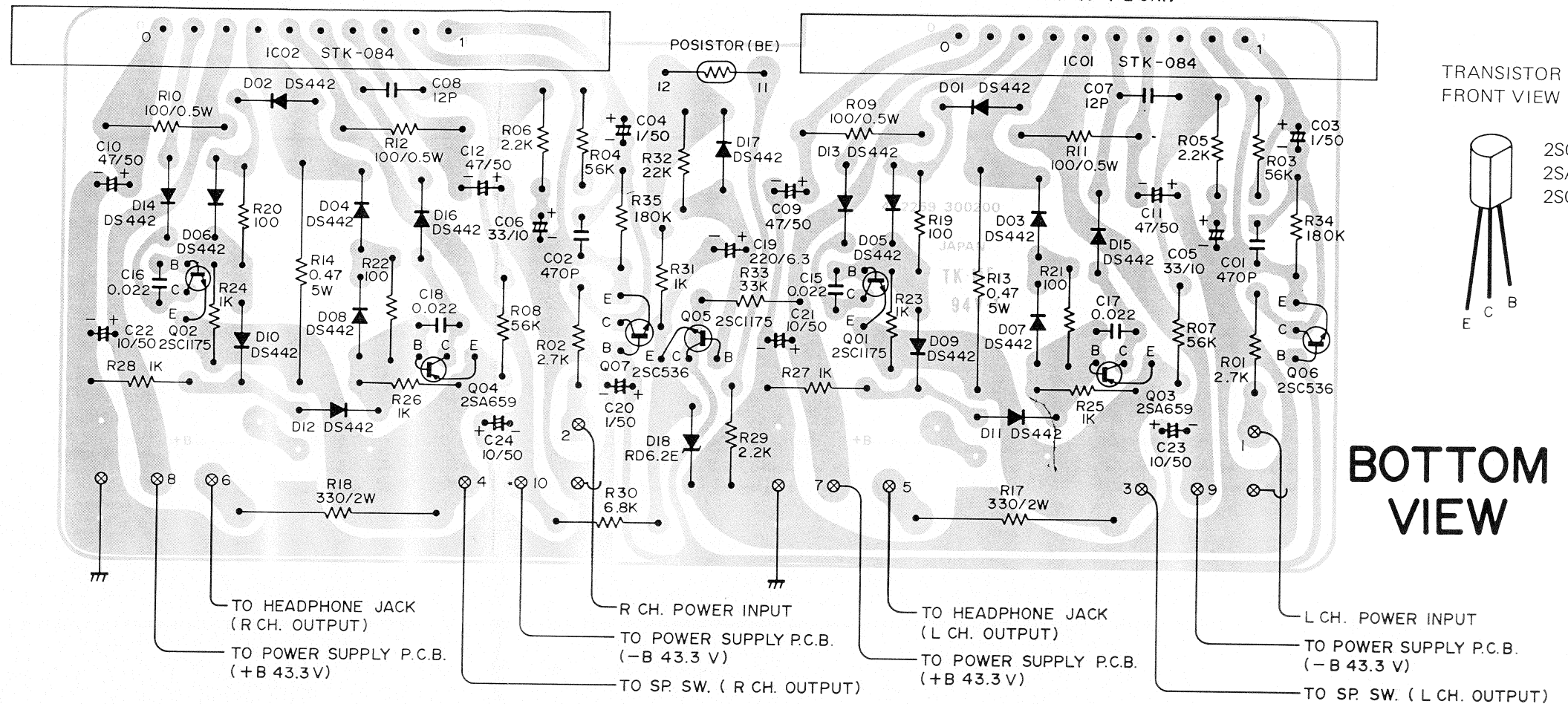

TRANSISTOR  
FRONT VIEW

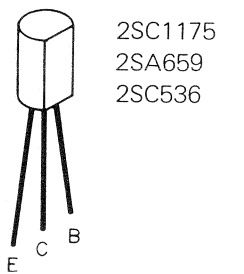

## BOTTOM VIEW

# POWER SUPPLY P.C.BOARD

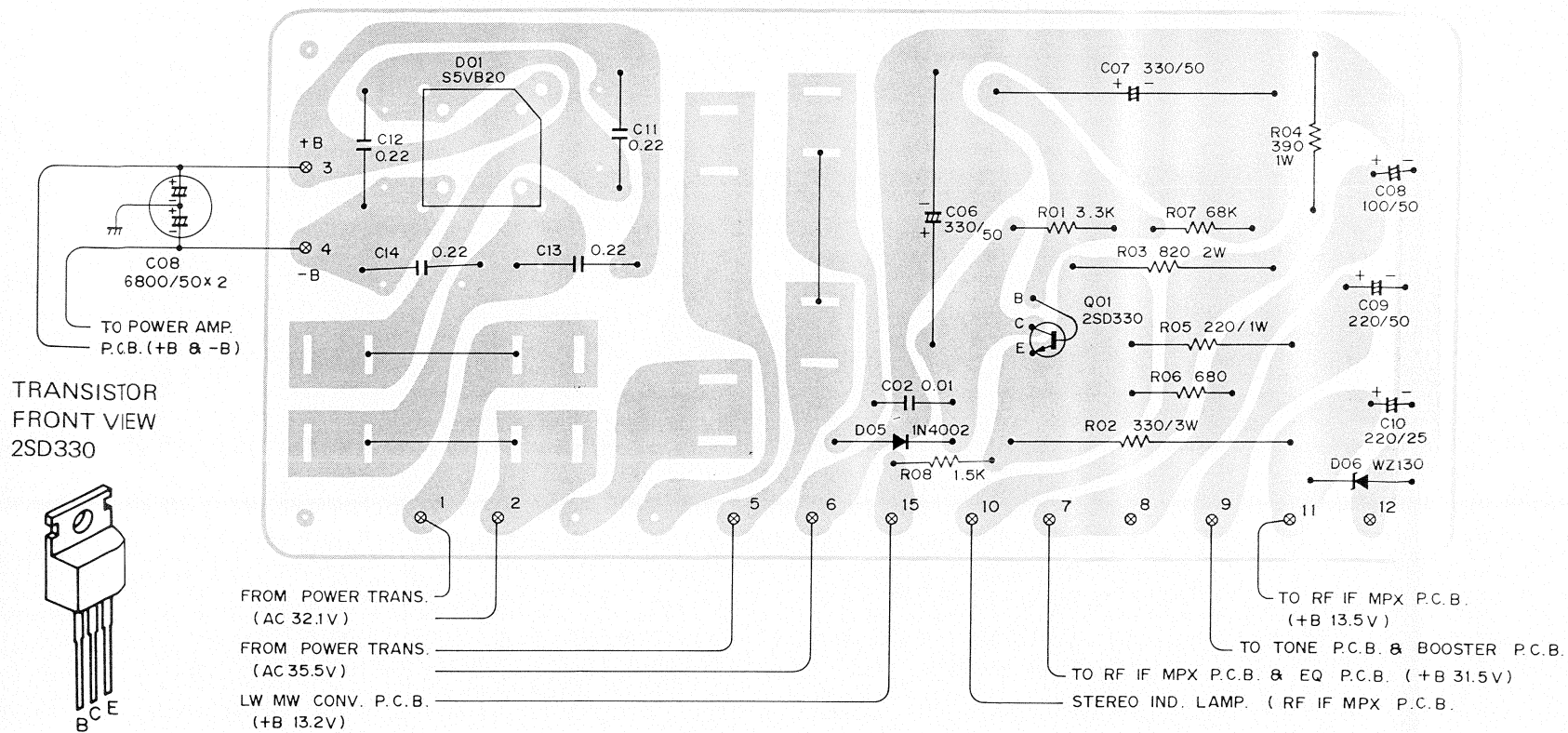

TRANSISTOR  
FRONT VIEW  
2SD330

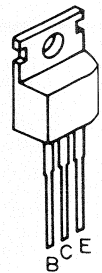

# DIAL LAMP P.C. BOARD

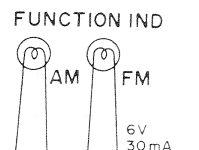
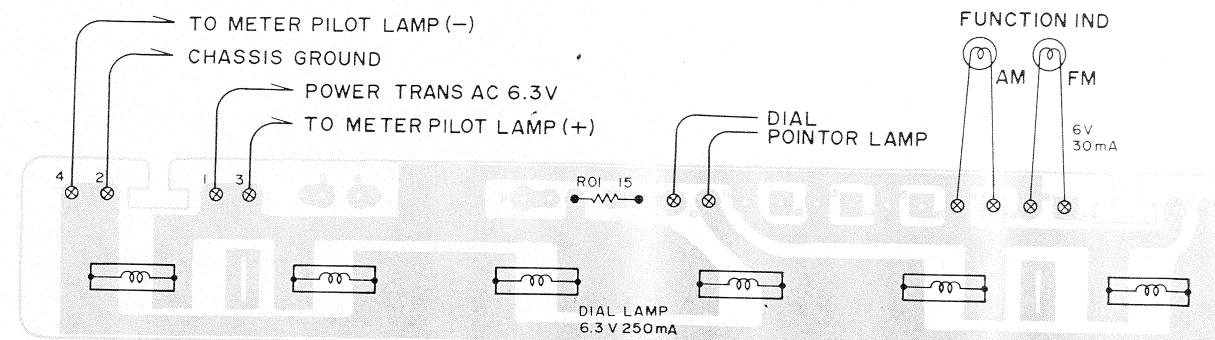

## BOTTOM VIEW

DIODE FRONT VIEW

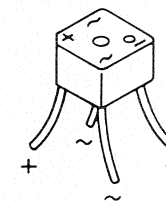

TRANSISTOR DC VOLTAGES				
SYMBOL No.	DEVICE	B	C	E
Q01	2SD330E	39.9	44.1	39.4

# PARTS LIST

## EQ PCB Assy 1310 4001 72120

Ref. No.	Part Number	Description
<b>CAPACITORS</b>		
C01, 02	C1EUBM474A	Sint, Alu 0.47 $\mu$ F 25V $\pm 20\%$
C03, 04	C1HCSK101SL	Ceramic 100pF 50V $\pm 20\%$
C05, 06	C1ERB-106A	Electrolytic 10 $\mu$ F 25V
C07, 08	C1HCSJ150SL	Ceramic 15pF 50V $\pm 5\%$
C09, 10	C1HFAJ153A	Mylar 0.015 $\mu$ F 50V $\pm 5\%$
C11, 12	C1HFAJ472A	Mylar 0.0047 $\mu$ F 50V $\pm 5\%$
C13, 14	C1VTRM105A	Tantalum 1 $\mu$ F 35V $\pm 20\%$
C15	C1VTRM106A	Tantalum 10 $\mu$ F 35V $\pm 20\%$
C16	C1HRB-227A	Electrolytic 220 $\mu$ F 50V

### SEMICONDUCTORS

C01, 02	TJJ-2SA763-5	TR 2SA763E
Q03, 04	203 5 5151 57089	TR 2SC1570LH

### RESISTORS

R01, 02	R2EDSJ823A	Carbon 82k	1/4W	$\pm 5\%$
R03, 04	R2EDSJ102A	Carbon 1k	1/4W	$\pm 5\%$
R05, 06	R2EDSJ154A	Carbon 150k	1/4W	$\pm 5\%$
R07, 08	R2EDSJ823A	Carbon 82k	1/4W	$\pm 5\%$
R09, 10	R2EDSJ105A	Carbon 1M	1/4W	$\pm 5\%$
R11, 12	R2EDSJ271A	Carbon 270	1/4W	$\pm 5\%$
R13, 14	R2EDSJ103A	Carbon 10k	1/4W	$\pm 5\%$
R15, 16	R2EDSJ684A	Carbon 680k	1/4W	$\pm 5\%$
R17, 18	R2EDSJ183A	Carbon 18k	1/4W	$\pm 5\%$
R19, 20	R2EDSJ334A	Carbon 330k	1/4W	$\pm 5\%$
R21	R2EDSJ104A	Carbon 100k	1/4W	$\pm 5\%$
R22	R2EDSJ272A	Carbon 2.7k	1/4W	$\pm 5\%$
R23	R2EDSJ471A	Carbon 470	1/4W	$\pm 5\%$

## BOOSTOR PCB Assy 1310 4001 79500

### CAPACITORS

C01, 02	C1HRB-105A	Electrolytic 1 $\mu$ F 50V
C03, 04	C1HRE-475AL	Electrolytic 4.7 $\mu$ F 50V
C05, 06	C1HCSJ150SL	Ceramic 15pF 50V $\pm 5\%$
C07	C1HRB-227A	Electrolytic 220 $\mu$ F 50V

### SEMICONDUCTORS

Q01, 02	2035 5151 57079	TR 2SC1570LG
---------	-----------------	--------------

### RESISTORS

R01, 02	R2EDSJ104A	Carbon 100k	1/4W	$\pm 5\%$
R03, 04	R2EDSJ274A	Carbon 270k	1/4W	$\pm 5\%$
R05, 06	R2EDSJ682A	Carbon 6.8k	1/4W	$\pm 5\%$
R07, 08	R2EDSJ102A	Carbon 1k	1/4W	$\pm 5\%$
R09	R2EDSJ222A	Carbon 2.2k	1/4W	$\pm 5\%$

## TONE PCB Assy 1310 4001 72133

Ref. No.	Part Number	Description
	4 2229 26180	VR-50k Volume
	4 2229 25380	VR-250k Balance
	4 2229 25390	VR-100k Bass/Treble
S7	4 2319 34060	SW Push 5 Key High Filter,
S6, S5		Mono Mode, Tape Monitor,
S8, S4		Muting Off, Loudness Contour

### CAPACITORS

C01, 02	C1HRE-105AL	Electrolytic 1 $\mu$ F 50V
C03, 04	C1HCSJ150SL	Ceramic 15pF 50V $\pm 5\%$
C05, 06	C1HRE-105AL	Electrolytic 1 $\mu$ F 50V
C07, 08	C1HFAJ103AL	Mylar 0.01 $\mu$ F 50V $\pm 5\%$
C09, 10	C1HRE-105AL	Electrolytic 1 $\mu$ F 50V
C11, 12	C1HCSJ150SL	Ceramic 15pF 50V $\pm 5\%$
C13, 14	C1HRE-475AL	Electrolytic 4.7 $\mu$ F 50V
C15, 16	C1HFAJ473A	Mylar 0.047 $\mu$ F 50V $\pm 5\%$
17, 18		
C19, 20	C1HFAJ222A	Mylar 0.0022 $\mu$ F 50V $\pm 5\%$
C23, 24	C1HRE-105AL	Electrolytic 1 $\mu$ F 50V
C25, 26	C1VTRM225A	Tantalum 2.2 $\mu$ F 35V $\pm 20\%$
C27, 28	C1HCSK470SL	Ceramic 47pF 50V $\pm 10\%$
C29, 30	C1HRE-475AL	Electrolytic 4.7 $\mu$ F 50V
C31, 32	C1HYSK681R	Ceramic 680pF 50V $\pm 10\%$
C33, 34	C1HFAJ154A	Mylar 0.15 $\mu$ F 50V $\pm 5\%$
C35	C1HRB-227A	Electrolytic 220 $\mu$ F 50V

### SEMICONDUCTORS

Q01, 02	2035 5151 57089	TR 2SC1570LH
03, 04		
05, 06		

### RESISTORS

R01, 02	R2EDSJ334A	Carbon 330k	1/4W	$\pm 5\%$
R03, 04	R2EDSJ102A	Carbon 1k	1/4W	$\pm 5\%$
R05, 06	R2EDSJ224A	Carbon 220k	1/4W	$\pm 5\%$
R07, 08	R2EDSJ334A	Carbon 330k	1/4W	$\pm 5\%$
R09, 10	R2EDSJ103A	Carbon 10k	1/4W	$\pm 5\%$
R11, 12	R2EDSJ334A	Carbon 330k	1/4W	$\pm 5\%$
R13, 14	R2EDSJ332A	Carbon 3.3k	1/4W	$\pm 5\%$
15, 16				
R17, 18	R2EDSJ102A	Carbon 1k	1/4W	$\pm 5\%$
R19, 20	R2EDSJ224A	Carbon 220k	1/4W	$\pm 5\%$
R21, 22	R2EDSJ334A	Carbon 330k	1/4W	$\pm 5\%$
R23, 24	R2EDSJ472A	Carbon 4.7k	1/4W	$\pm 5\%$
R25, 26	R2EDSJ104A	Carbon 100k	1/4W	$\pm 5\%$
R27, 28	R2EDSJ123A	Carbon 12k	1/4W	$\pm 5\%$
R29, 30	R2EDSJ822A	Carbon 8.2k	1/4W	$\pm 5\%$
R31, 32	R2EDSJ103A	Carbon 10k	1/4W	$\pm 5\%$
33, 34				
R35, 36	R2EDSJ223A	Carbon 22k	1/4W	$\pm 5\%$
R37, 38	R2EDSJ564A	Carbon 560k	1/4W	$\pm 5\%$
R39, 40	R2EDSJ472A	Carbon 4.7k	1/4W	$\pm 5\%$
R41, 42	R2EDSJ821A	Carbon 820	1/4W	$\pm 5\%$
R43, 44	R2EDSJ272A	Carbon 2.7k	1/4W	$\pm 5\%$
R45	R2EDSJ101A	Carbon 100	1/4W	$\pm 5\%$

## POWER AMP PCB Assy 1310 4001 79305

Ref. No.	Part Number	Description
	HLL-PTH487A-B	Posistor
<b>CAPACITORS</b>		
C01, 02	C1HCSK471SL	Ceramic 470pF 50V $\pm 10\%$
C03, 04	C1HRE-105AL	Electrolytic 1 $\mu$ F 50V
C05, 06	C1ARB-336A	Electrolytic 33 $\mu$ F 10V
C07, 08	C1HCDJ120SL	Ceramic 12pF 50V
C09, 10	C1HRB-476A	Electrolytic 47 $\mu$ F 50V
11, 12		
C15, 16	C1HFAM223A	Mylar 0.022 $\mu$ F 50V $\pm 20\%$
17, 18		
C19	C0JRB-227A	Electrolytic 220 $\mu$ F 6.3V
C20	C1HRB-105A	Electrolytic 1 $\mu$ F 50V
C21, 22	C1HRB-106A	Electrolytic 10 $\mu$ F 50V
23, 24		

### SEMICONDUCTORS

D01, 02	2055 9040 44210	Diode DS-442
03, 04, 05, 06, 07, 08, 09, 10, 11, 12, 13, 14, 15, 16, 17		
D18	DNN-RD6.2E	Diode RD-6.2E
IC01, 02	2065 6390 08410	IC STK-084
Q01, 02	2035 6701 17550	TR 2SC1175E
Q03, 04	2035 6800 65950	TR 2SA659E
Q05	2035 6701 17550	TR 2SC1175E
Q06, 07	2035 5100 53650	TR 2SC536E

### RESISTORS

R01, 02	R2EDSJ272A	Carbon 2.7k	1/4W	$\pm 5\%$
R03, 04	R2EDSJ563A	Carbon 56k	1/4W	$\pm 5\%$
R05, 06	R2EDSJ222A	Carbon 2.2k	1/4W	$\pm 5\%$
R07, 08	R2EDSJ563A	Carbon 56k	1/4W	$\pm 5\%$
R09, 10	R2HXB101A	Oxide Metal Film 100 1/2W	5%	
11, 12				
R13, 14	R3HEIKR47A	Cement 0.47	5 W	$\pm 10\%$
R17, 18	R3DXBJ331A	Oxide Metal Film 330 2W	$\pm 5\%$	
R19, 20	R2EDSJ101A	Carbon 100	1/4W	$\pm 5\%$
21, 22				
R23, 24	R2EDSJ102A	Carbon 1k	1/4W	$\pm 5\%$
25, 26				
27, 28				
R29	R2EDSJ222A	Carbon 2.2k	1/4W	$\pm 5\%$
R30	R2EDSJ682A	Carbon 6.8k	1/4W	$\pm 5\%$
R31	R2EDSJ102A	Carbon 1k	1/4W	$\pm 5\%$
R32	R2EDSJ223A	Carbon 22k	1/4W	$\pm 5\%$
R33	R2EDSJ333A	Carbon 33k	1/4W	$\pm 5\%$
R34, 35	R2EDSJ184A	Carbon 180k	1/4W	$\pm 5\%$

## POWER SUPPLY PCB Assy 1310 4001 93201

Ref. No.	Part Number	Description
<b>CAPACITORS</b>		
C02	C2HYDP103A	Ceramic 0.01 $\mu$ F 500V +100,-0%
C06, 07	C1HRT-337A	Electrolytic 330 $\mu$ F 50V
C08	C1HRB-107A	Electrolytic 100 $\mu$ F 50V
C09	C1HRB-227A	Electrolytic 220 $\mu$ F 50V
C10	C1ERB-227A	Electrolytic 220 $\mu$ F 25V
C11, 12	4 2239 21220	Mylar 0.22 $\mu$ F 250V $\pm 10\%$
13, 14		

# PARTS LIST

Ref. No.	Part Number	Description
<b>SEMICONDUCTORS</b>		
D01	DDD-S5VB20	Diode S5VB20
D05	DGG-1N4002	Diode 1N4002
D06	DJJ-WZ-130	Diode WZ-130
Q01	2035 8220 33050	TR 2SD330E

### RESISTORS

R01	R2EDSJ332A	Carbon 3.3k	1/4W	$\pm 5\%$
R02	R3WXB331A	Oxide Metal Film 330 3W	$\pm 5\%$	
R03	R3DXBJ821A	Oxide Metal Film 820 2W	$\pm 5\%$	
R04	R3AXB391A	Oxide Metal Film 390 1W	$\pm 5\%$	
R05	R3AXB221A	Oxide Metal Film 220 1W	$\pm 5\%$	
R06	R2EDSJ681A	Carbon 680	1/4W	$\pm 5\%$
R07	R2EDSJ683A	Carbon 68k	1/4W	$\pm 5\%$
R08	R2EDSJ152A	Carbon 1.5k	1/4W	$\pm 5\%$

## DIAL LAMP PCB Assy 1310 4001 72161

Ref. No.	Part Number	Description
	4 2359 20930	Lamp Holder
	4 6129 20280	Pilot Lamp, Fuse Type 6.3V 250mA
63-1	4 6129 20726	Pilot Lamp AM, FM IND 6V 30mA

### RESISTORS

R01	R2EDSJ150A	Carbon 15	1/4W	$\pm 5\%$
-----	------------	-----------	------	-----------

## LW/MW Conv. P.C. Assy 1310 4001 75303

Ref. No.	Part Number	Description
RE01, 02	4 2329 20210	Leed Relay
TC01, 03	4 2249 20310	Variable Capacitor
TC02, 04	4 2249 20440	Variable Capacitor
	4 2589 20851	MW OSC Coil
	4 2589 20860	LW OSC Coil

### CAPACITORS

C01, 02	C1HYSE473A	Ceramic 0.047 $\mu$ F 50V +80,-20%
03		
C04	C1HSEJ341A	Styrol Con. 340pF 50V $\pm 5\%$
C05	C1HSEJ151A	Styrol Con. 150pF 50V $\pm 5\%$
C06	C1HYSE473A	Ceramic 0.047 $\mu$ F 50V +80,-20%
C08	C1HCDJ150SL	Ceramic 15pF 50V $\pm 5\%$
C10	C1HCDJ560SL	Ceramic 56P 50V $\pm 5\%$

### SEMICONDUCTORS

Q01, 02	2035 6500 04160	FET 2SK 41F
---------	-----------------	-------------

### RESISTORS

R01	R2EDSJ103A	Carbon 10k	1/4W	$\pm 5\%$
R02, 07	R2EDSJ155A	Carbon 1.5M	1/4W	$\pm 5\%$
R03, 08	R2EDSJ824A	Carbon 820k	1/4W	$\pm 5\%$
R04, 09	R2EDSJ472A	Carbon 4.7k	1/4W	$\pm 5\%$
R05	R2EDSJ152A	Carbon 1.5k	1/4W	$\pm 5\%$
R06, 10	R2EDSJ102A	Carbon 1k	1/4W	$\pm 5\%$
11				

# POINT TO POINT WIRING DIAGRAM

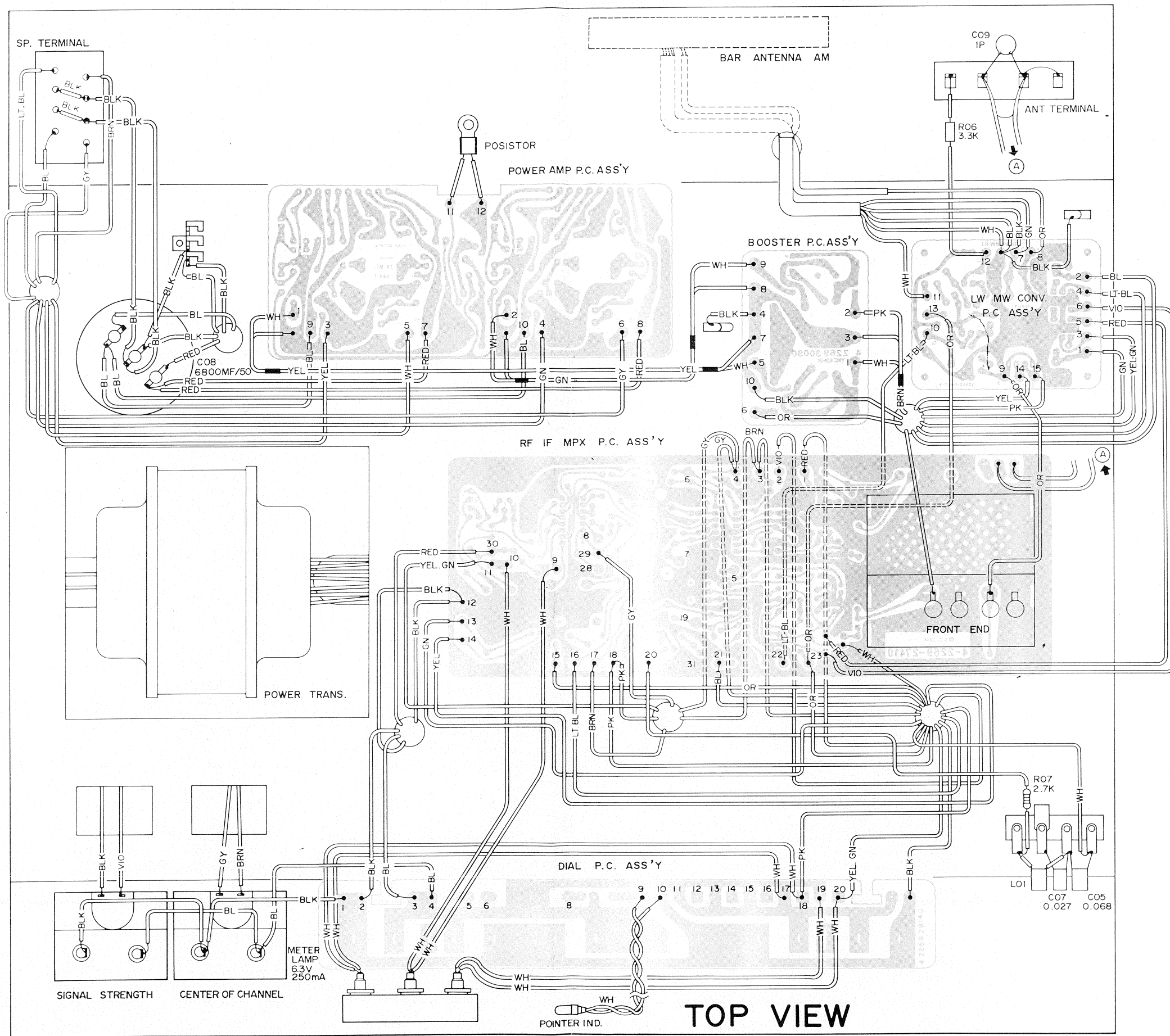

TOP VIEW



# POINT TO POINT WIRING DIAGRAM

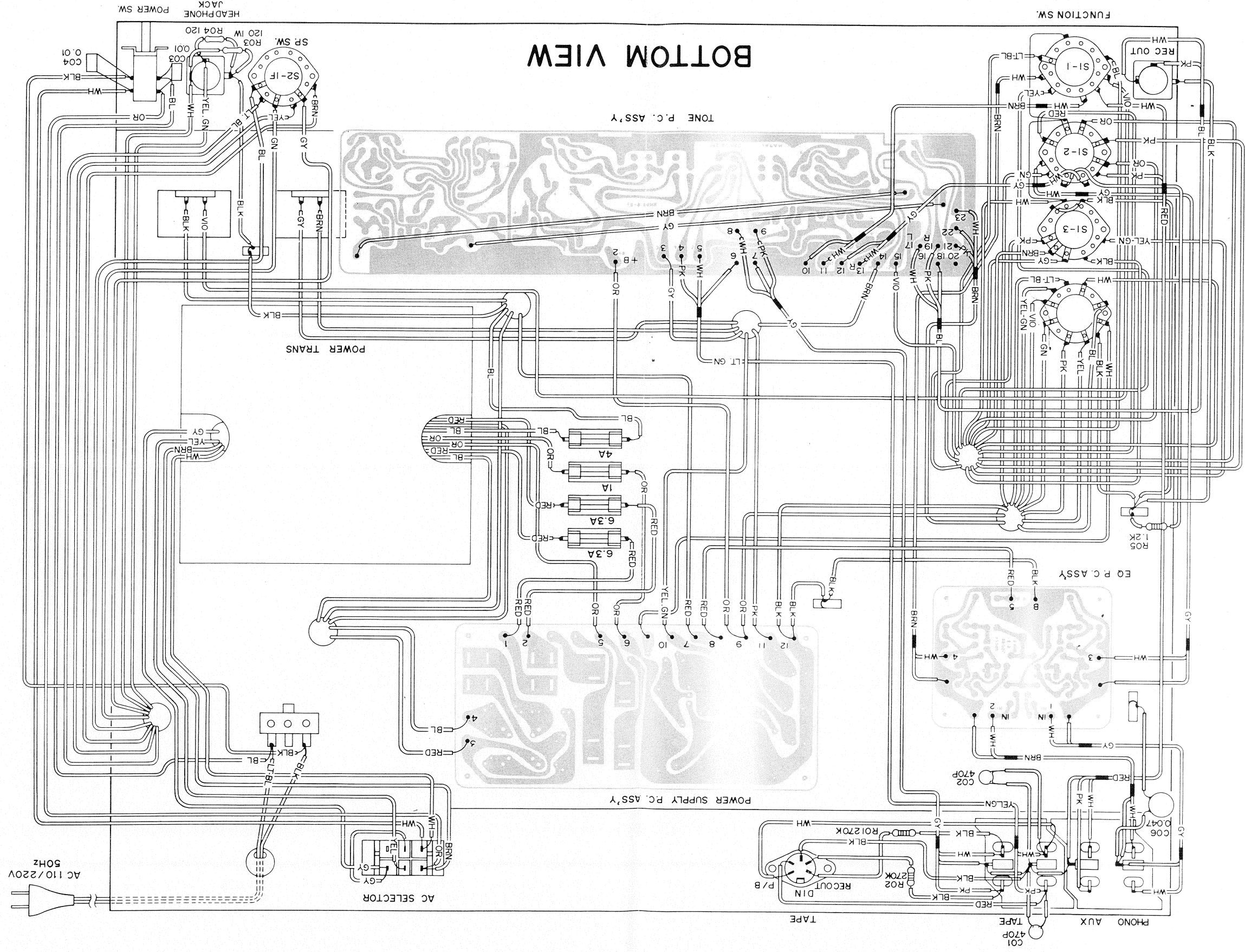

# BOTTOM VIEW

# SCHEMATIC D

Q04 2SC930 D D01 ~ 04 DS442

Q01 2SC536 E

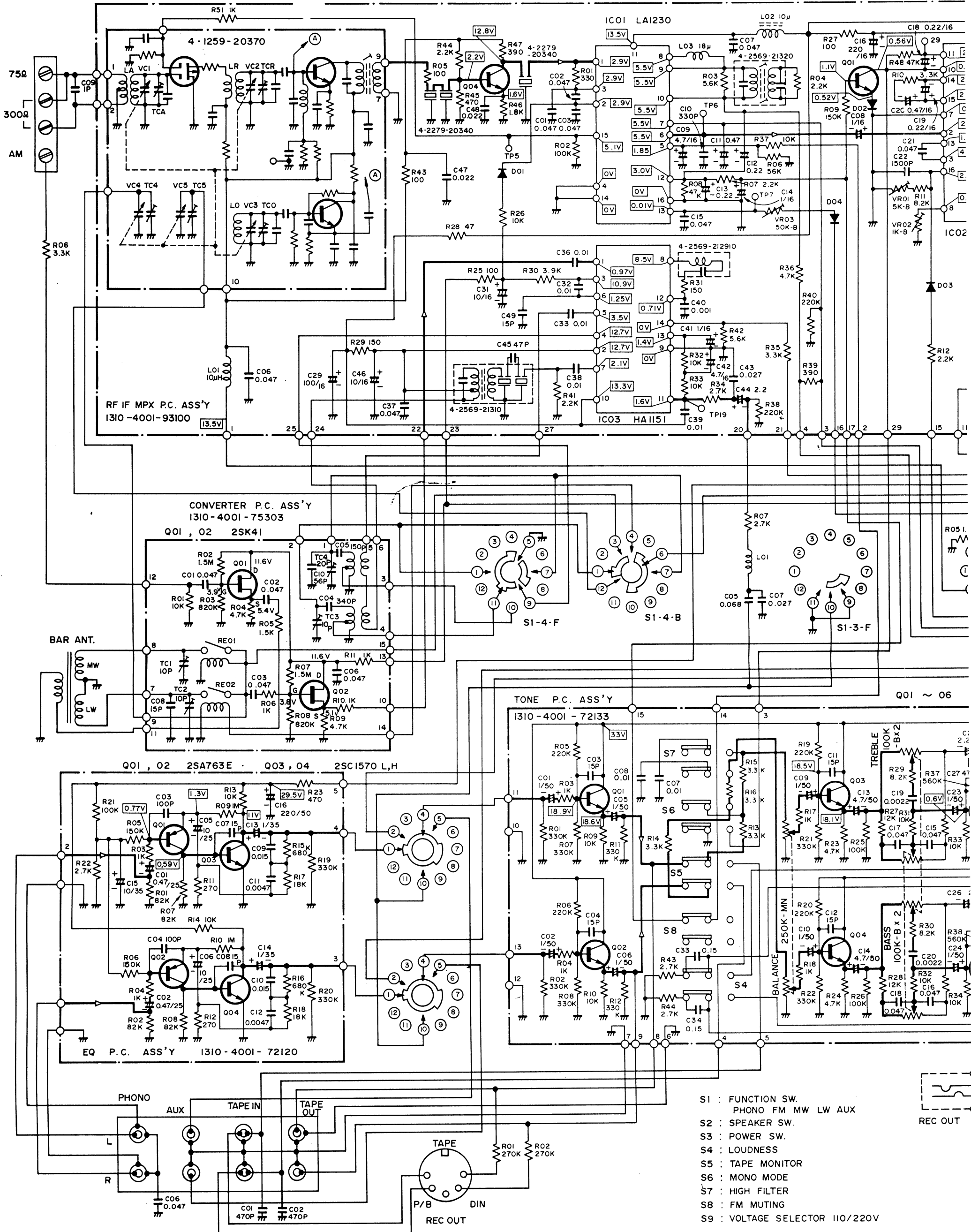

- S1 : FUNCTION SW.  
PHONO FM MW LW AUX
- S2 : SPEAKER SW.
- S3 : POWER SW.
- S4 : LOUDNESS
- S5 : TAPE MONITOR
- S6 : MONO MODE
- S7 : HIGH FILTER
- S8 : FM MUTING
- S9 : VOLTAGE SELECTOR 110/220V

# PC DIAGRAM

2SC536 E

Q02, 03

2SC1570 L,H

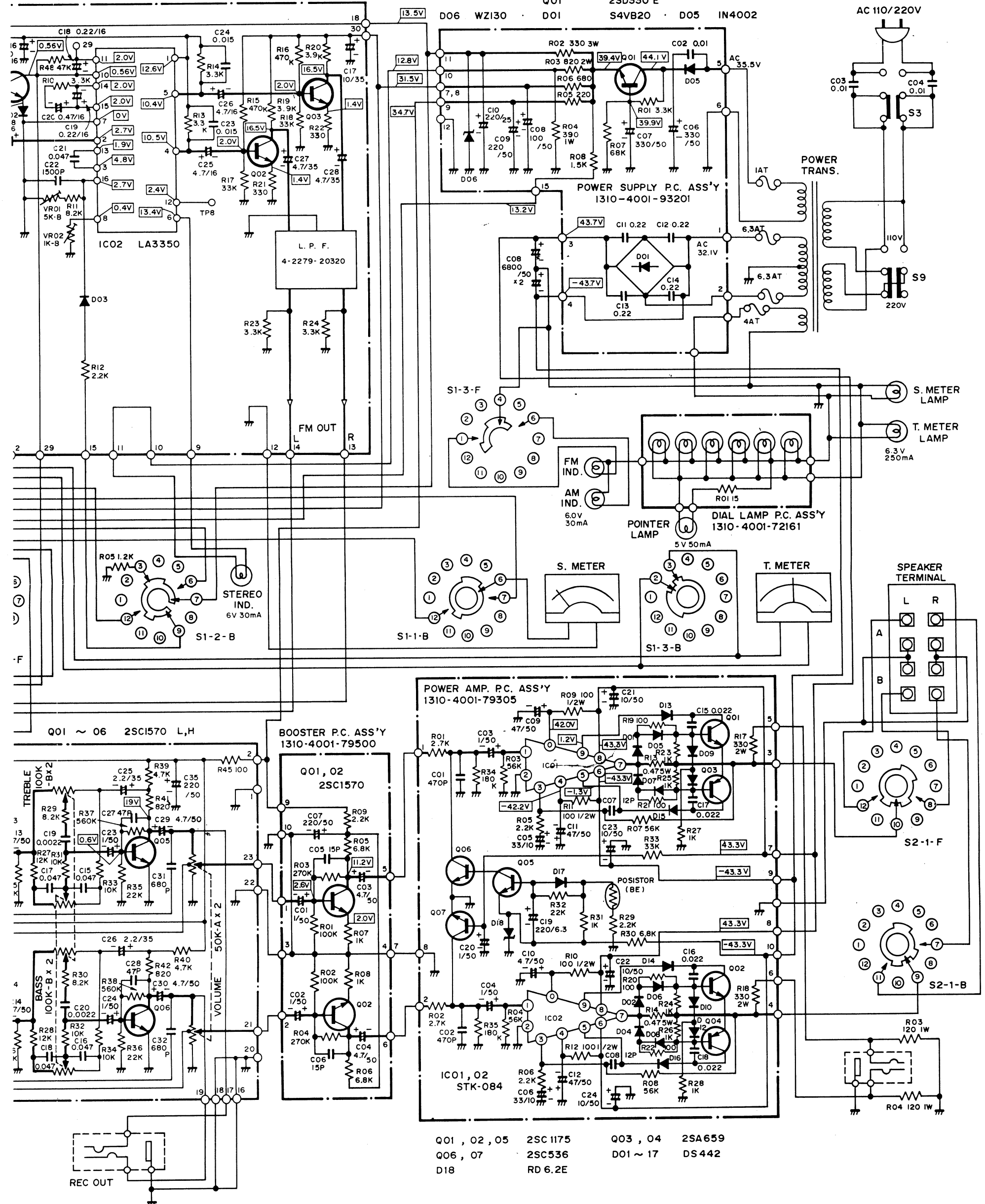

- |             |         |          |        |
|-------------|---------|----------|--------|
| Q01, 02, 05 | 2SC1175 | Q03, 04  | 2SA659 |
| Q06, 07     | 2SC536  | D01 ~ 17 | DS442  |
| D18         | RD 6.2E |          |        |

10V