

176

SERVICE MANUAL

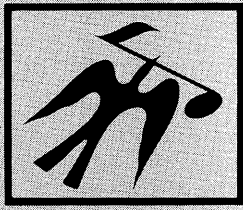

FISHER[®]

RS-120

AM/FM STEREO RECEIVER



The first name in high fidelity

US

SPECIFICATIONS

AMPLIFIER SECTION

FTC power 8 ohms load	20 W/Ch.
Power bandwidth	20 ~ 20000 Hz
Rated maximum T.H.D. at 8 ohms load	0.09 %
Frequency response	
Phono (Deviation from RIAA curve,	
20 ~ 20000 Hz)	± 0.8 dB
Aux/Tape (+0, -1dB)	10 ~ 30000 Hz
Phono sensitivity/Overload	2.5/130 mV
Aux. Tape sensitivity/Impedance	150 mV/47 k ohm
Graphic Equalizer	
50 Hz	± 10 dB
250 Hz	± 10 dB
1 kHz	± 10 dB
4.5 kHz	± 10 dB
15 kHz	± 10 dB
Loudness compensation (volume at -30 dB)	
100 Hz	+ 8 dB
10 kHz	+ 3 dB
Signal-to-Noise ratio (IHF "A" filter)	
Phono	70 dB
Aux/Tape	90 dB

TUNER SECTION

FM	
FM Frequency Range	87.5 ~ 108 MHz
Usable sensitivity (IHF)	2.0 μ V/11.2 dBf

TUNER SECTION

FM	
Ultimate Signal-to-Noise ratio	
Mono	70 dB
Stereo	65 dB
Total Harmonic Distortion at 1 kHz.	
Mono	0.4 %
Stereo	0.7 %
Capture ratio	1.5 dB
Alternate channel selectivity	55 dB
Spurious response rejection	70 dB
Image rejection	50 dB
IF rejection	75 dB
AM rejection	55 dB
Stereo separation at 1 kHz	40 dB
AM	
MW Frequency Range	520 ~ 1640 kHz
Sensitivity (IHF)	400 μ V/m
Selectivity	35 dB
Signal-to-Noise ratio	45 dB
Image rejection	50 dB
IF rejection	30 dB

GENERAL

Power Source	AC 120V, 60 Hz
--------------	----------------

NOTE : Specifications are subject to change without prior notice.

ALIGNMENT PROCEDURES

AM ALIGNMENT INSTRUMENTS

AM IF Sweep Generator, AM RF Signal Generator, VTVM, and Oscilloscope.

Place the controls and switches in the following positions unless otherwise instructed.

NOTE

Function	AM	Volume	0 (minimum)	Balance	0 (center)
Tape Monitor	Source	Treble, Bass	0 (center)	Loudness, High and Low Filters	OFF (outer position)
Speakers	A position where a pair of test speakers are connected.				

Keep the input signal level as low as possible to avoid the AVC action.

AM IF ALIGNMENT

Step	Generator Connection	Input Signal	Test Equipment Connection	Adjustment
1.	Sweep generator to J5.	455 kHz	Oscilloscope to TP5.	Tune T3, 4 for highest and most symmetrical IF response. See Figure 1.

Figure 1.

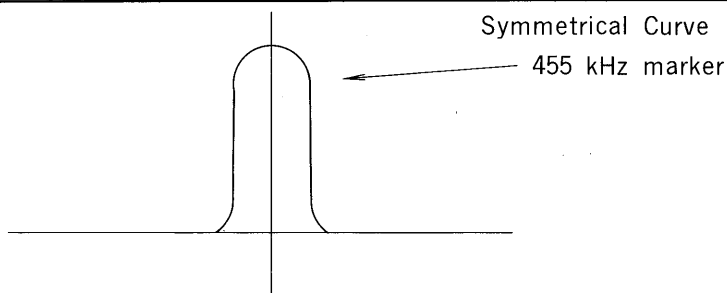

AM SIGNAL STRENGTH METER ADJUSTMENT

Step	Generator Connection	Input Signal	Receiver Dial Setting	Test Equipment Connection	Adjustment
1.	Loop Ant.	1,000 kHz 1 kHz, 30% mod. 15 mV/m	1,000 kHz	—	Adjust SVR3 for lighting of 5 LED's in the Signal Strength Indicator.

ALIGNMENT PROCEDURES

AM RF ALIGNMENT

Step	Generator Connection	Input Signal	Receiver Dial Setting	Test Equipment Connection	Adjustment
1.		515 KHz, 1 KHz, 30% mod.	Lowest end	Connect VTVM's in parallel with the test speakers. Adjust VOLUME control for 2V readings on the VTVM's.	Adjust L7 for maximum output.
2.	Loop Ant.	1,650 KHz, 1 KHz, 30% mod.	Highest end		Adjust CT5 for maximum output.
3.	1 mV/m	600 KHz, 1 KHz, 30% mod.	600 KHz		Adjust L6 for maximum output.
4.		1,400 KHz, 1 KHz, 30% mod.	1,400 KHz		Adjust CT4 for maximum output.
5.	Repeat above steps until no further change is noted in any of the AM RF adjustment.				

FM ALIGNMENT INSTRUMENTS

FM IF Sweep Generator, Stereo Signal Generator, FM Generator, Frequency Counter, VTVM, and Oscilloscope.

NOTE

Place the FUNCTION Switch in the FM position. Leave all other selectors and switches in the positions as under NOTE of AM ALIGNMENT unless otherwise instructed.

Keep the input signal level as low as possible to avoid the AVC action.

FM IF ALIGNMENT

Step	Generator Connection	Input Signal	Test Equipment Connection	Adjustment
1.	Sweep generator to TP1 thru 0.02 ceramic capacitor	10.7 MHz	Oscilloscope to TP2	Tune T1, T2, for highest and most symmetrical "S" curve. See Figure 2.

Figure 2.

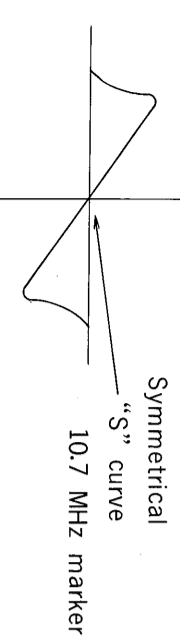
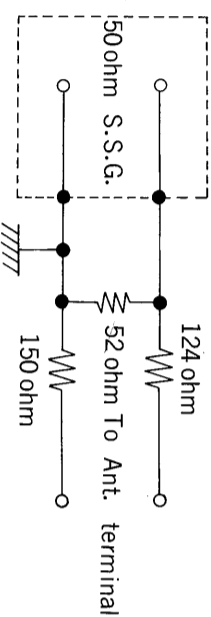

Figure 3.



FM RF ALIGNMENT

Step	Generator Connection	Input Signal	Receiver Dial Setting	Test Equipment Connection	Adjustment
1.	300 ohm input thru dummy ant. See Figure 3.	87.35 MHz, 1 KHz, 100% mod. 100 μ V	Lowest end	Connect VTVM's in parallel with the test speakers. Adjust VOLUME control for 2V readings on the VTVM's	Adjust L3 for maximum output.
2.		108.25 MHz, 1 KHz, 100% mod. 100 μ V	Highest end		Adjust CT3 for maximum output.
3.		90 MHz, 1 KHz, 100% mod. 100 μ V	90 MHz		Adjust L2 for maximum output.
4.					Adjust L1 for maximum output.
5.		106 MHz, 1 KHz, 100% mod. 100 μ V	106 MHz		Adjust CT2 for maximum output.
6.					Adjust CT1 for maximum output.
7.	Repeat above steps until no further change is noted in any of the FM RF adjustment. Reduce RF input level if the limiting action is taking place.				

FM SIGNAL STRENGTH METER ADJUSTMENT

Step	Generator Connection	Input Signal	Receiver Dial Setting	Test Equipment Connection	Adjustment
1.	300 ohm input thru dummy ant. See Figure 3.	98 MHz, 1 KHz, 100% mod. 500 μ V	98 MHz		Adjust SVR2 for lighting of 5 LED's in the Signal Strength Indicator

FM MPX ADJUSTMENT (See Figure 4.)

NOTE: The FM IF Alignment must be completed before attempting this FM MPX adjustment. Poor IF alignment will result in poor FM MPX adjustment.

Be sure the FUNCTION Selector switch is in the FM position, and the MONO/FM MUTE switch is in the FM MUTE (outer) position.

Step	Generator Connection	Input Signal	Stereo Signal Generator	Receiver Dial Setting	Test Equipment Connection	Adjustment
1.	No Connection	No Signal	No Signal	Any setting where no external signal received	Connect frequency Counter to TP6.	Adjust SVR4 for 19 KHz on the counter.
2.	Thru dummy Ant. See Figure 3.	98 MHz, 500 μ V	19 KHz, 10% mod. 1 KHz, 90% mod. Right channel only	98 MHz	Connect VTVM's in parallel with the test speakers, or 8 ohm dummy loads.	Adjust VOLUME Control for 2V on the Right VTVM. Then adjust SVR5 for minimum (less than 20mV) on the Left VTVM.
3.			19 KHz, 10% mod. 1 KHz, 90% mod. Left channel only.			Adjust VOLUME Control for 2V on the Left VTVM. Then adjust SVR5 for minimum (less than 20mV) on the Right VTVM.
4.	Repeat the Steps 2 and 3 until the minimum readings on the both channels are balanced.					

Figure 4.

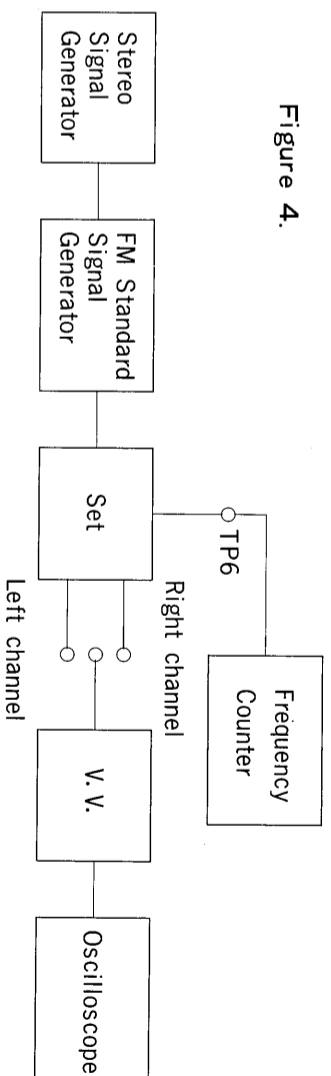

FM MUTING LEVEL ADJUSTMENT

Step	Generator Connection	Input Signal	Receiver Dial Setting	Test Equipment Connection	Adjustment
1.	Dummy Antenna. See Figure 3.	98 MHz, 1 KHz, 100% mod. 5 μ V	98 MHz	Connect VTVM across TP2 and ground. (FM MUTE SWITCH ON)	Adjust SVR1 for the point where 1 KHz output appears

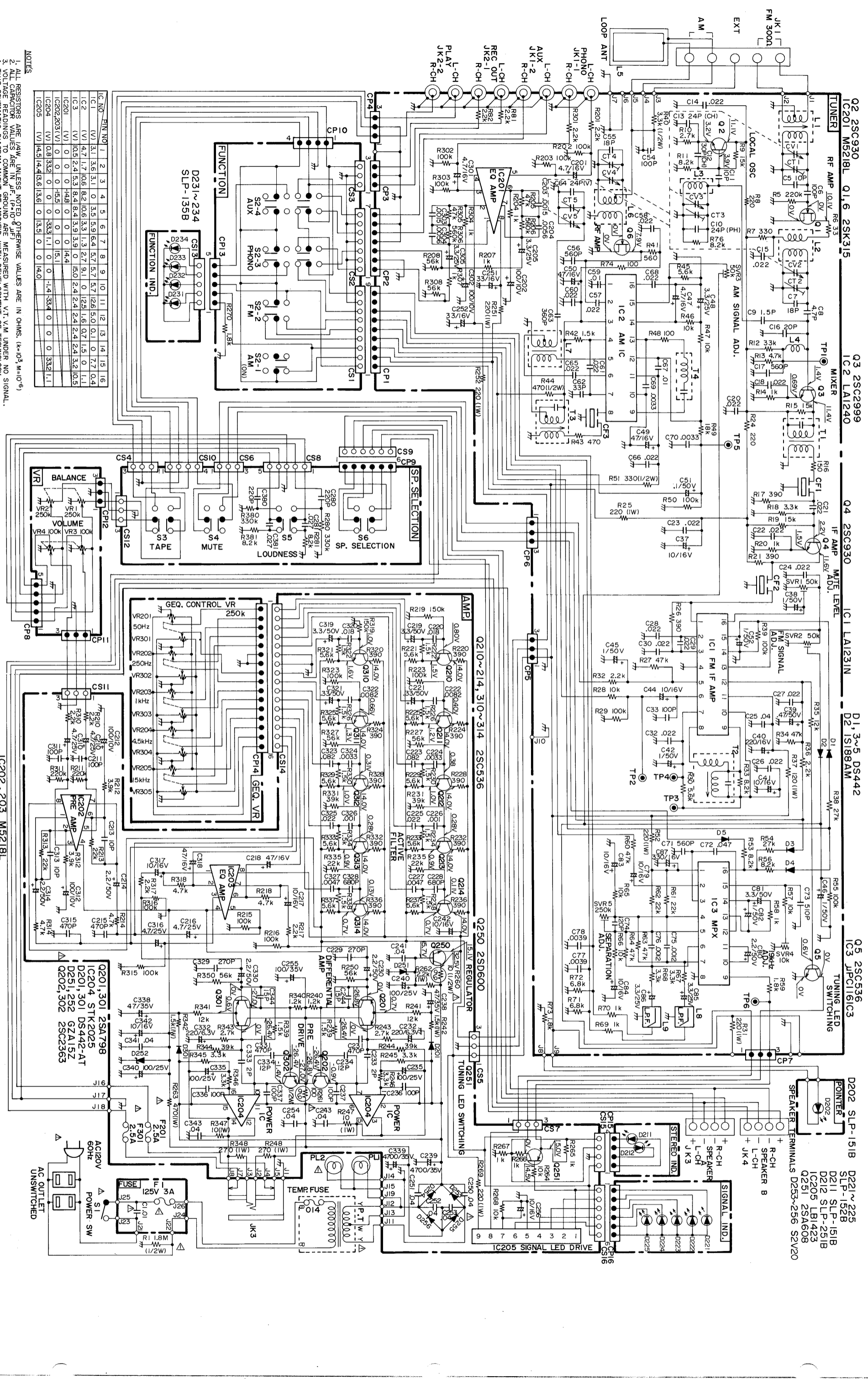

IC NO.	2IN	NO	1	2	3	4	5	6	7	8	9	10	11	12	13	14	15	16
IC1	(V)	3.1	3.6	3.1	0	3.5	5.9	6.4	5.7	5.7	12.6	5.0	0.1	0	7.7	0.4		
IC2	(V)	4.7	1.7	10.6	8.2	10.6	3.3	1.3	2.7	9.1	0.125	1.6	0.7	1.5	0	1.1		
IC3	(V)	0.5	2.4	5.3	8.4	8.4	3.9	3.9	0	15.0	2.4	2.4	2.4	2.4	3.2	10.5		
IC201	(V)	0	0	0	0	0	0	0	0	0	0	0	0	0	0	0		
IC202	(V)	0.8	3.3	0	0	0	0	0	0	0	0	0	0	0	0	0		
IC203	(V)	4.5	14.4	13.6	13.6	0	13.5	0	0	0	0	0	0	0	0	0		

NOTES
 1. ALL RESISTORS ARE 1/4W, UNLESS NOTED OTHERWISE VALUES ARE IN OHMS. (K=10³ M=10⁶)
 2. ALL CAPACITOR VALUES ARE IN μF. (P=10 μF) UNLESS NOTED OTHERWISE VALUES ARE IN OHMS. (K=10³ M=10⁶)
 3. VOLTAGE READINGS TO COMMON GROUND ARE MEASURED WITH V.T.V.M. UNDER NO SIGNAL.
 4. THIS SCHEMATIC DIAGRAM MIGHT BE MODIFIED WITH DEVELOPMENT OF TECHNOLOGY.

- Q2 2SC930
- C201 M5218L Q1,6 2SK315
- Q3 2SC2999
- IC2 LA1240
- Q4 2SC930
- IC1 LA1231N
- D1 3~5 DS442
- D2 IS188AM
- Q5 2SC536
- IC3 JPC116IC3
- D202 SLP-151B
- D221~225 SLP-152B
- D211 SLP-151B
- D212 SLP-251B
- IC205 LB1423
- Q251 2SA608
- D253~256 S2V20

TUNER P. C. B. Bottom

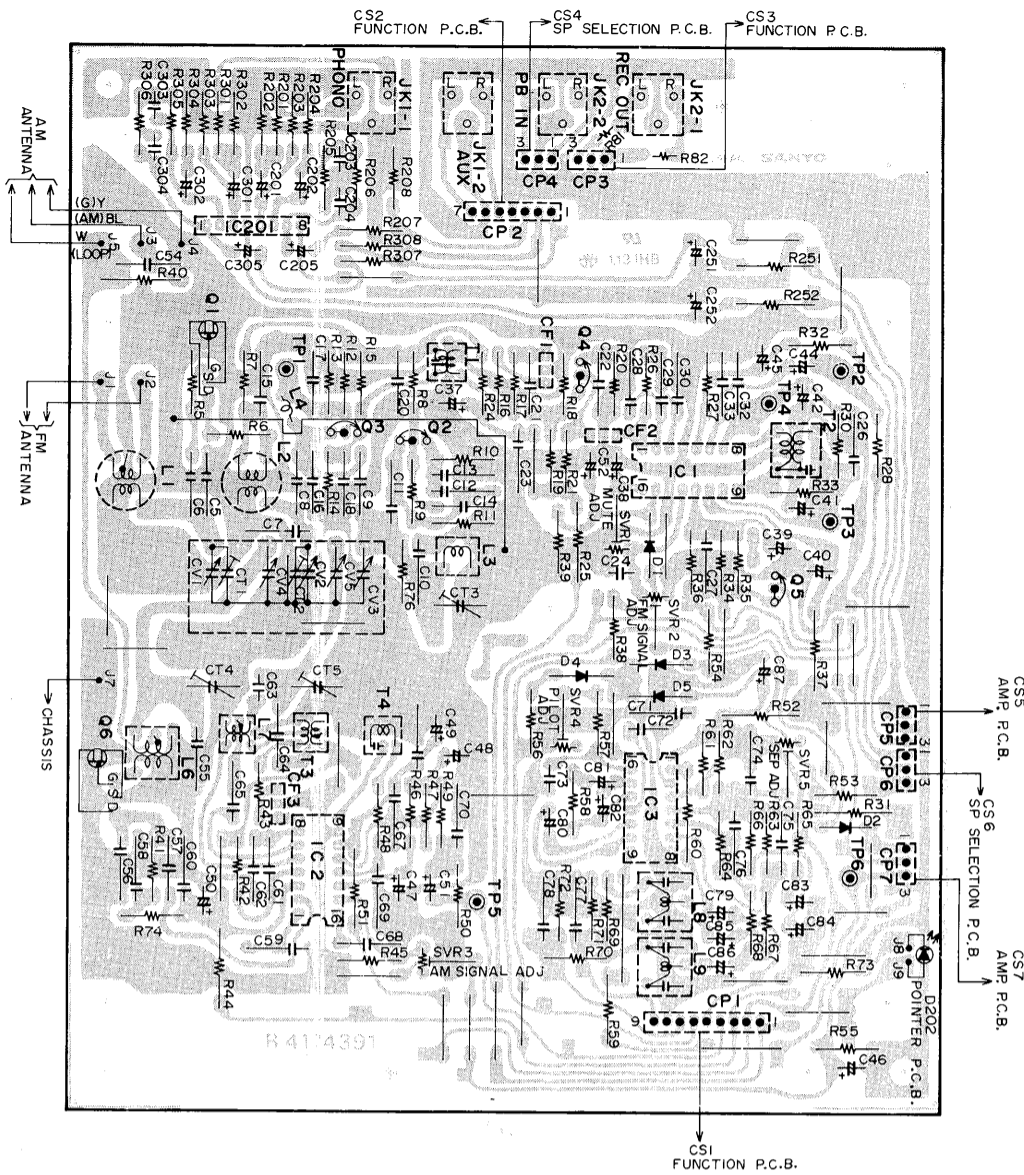

AMP P. C. B. Bottom

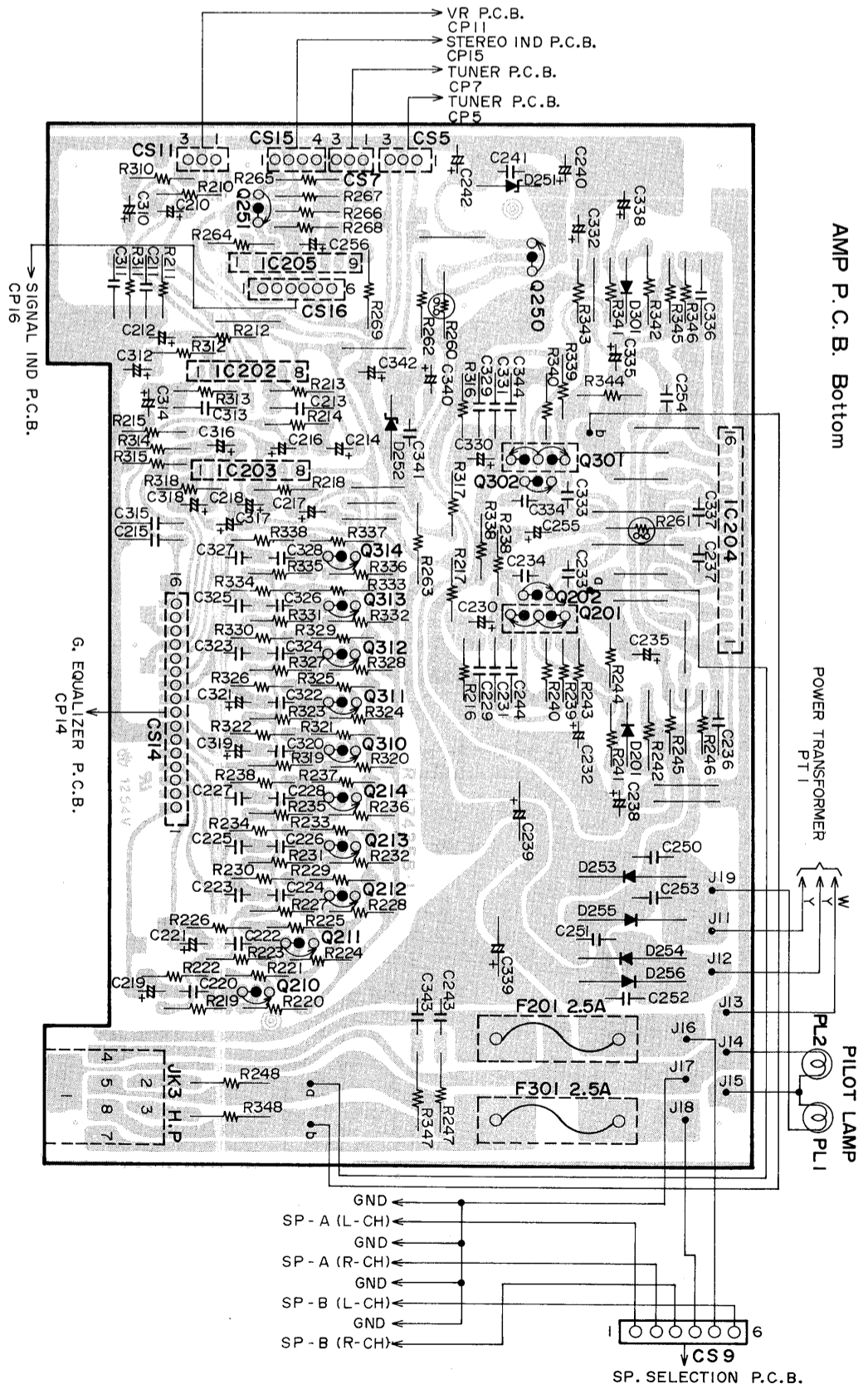

SIGNAL IND P. C. B. Bottom



FUNCTION IND P. C. B. Bottom

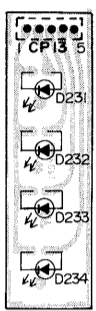

FUNCTION P. C. B. Bottom

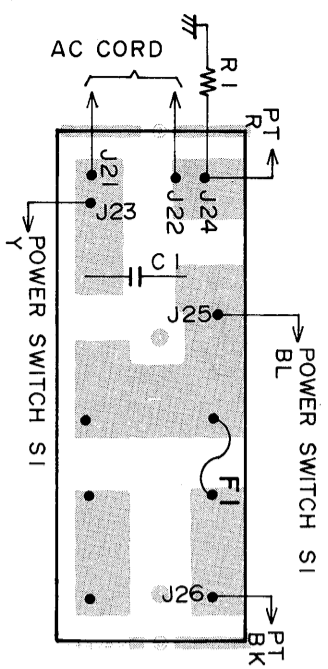

GEQ VR P. C. B. Bottom

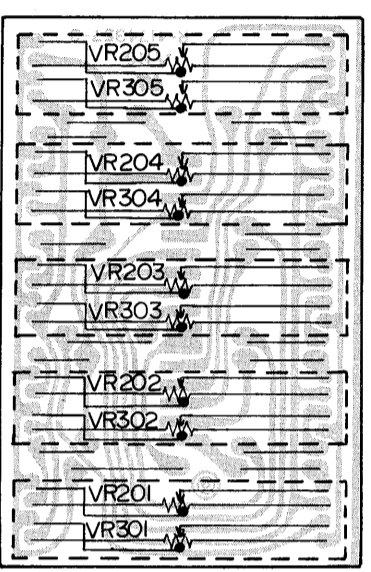

Fuse P. C. B. Bottom

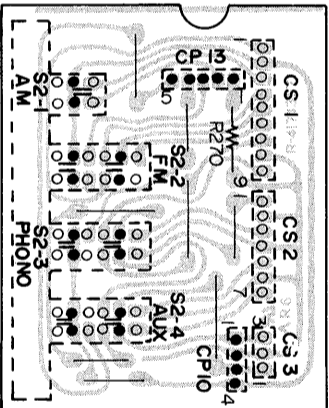

SP SELECTION P. C. B. Bottom

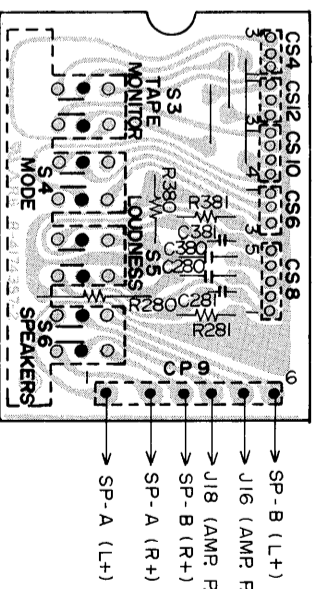

STEREO IND P. C. B. Bottom



VR P. C. B. Bottom

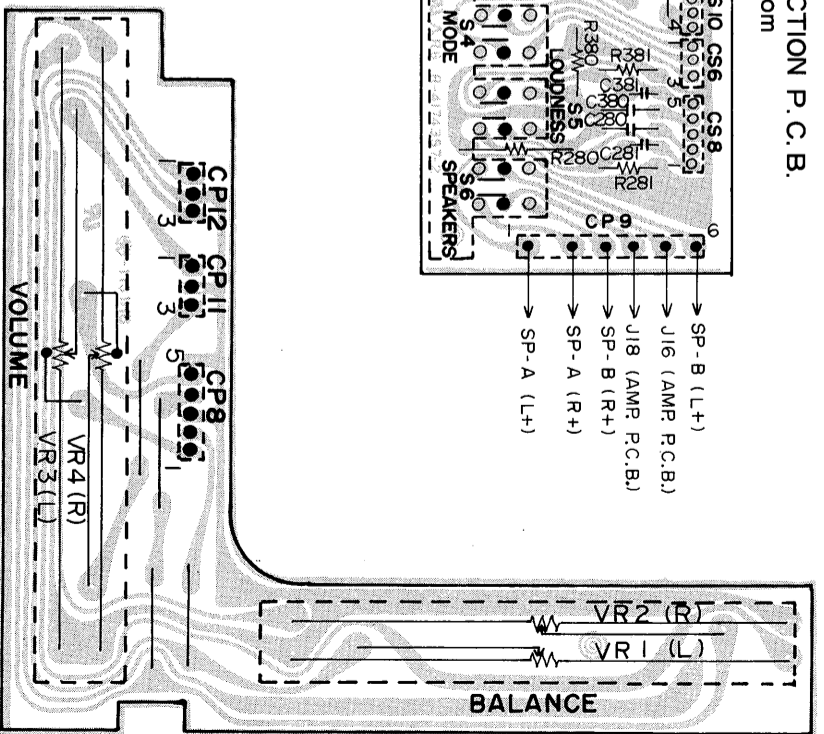

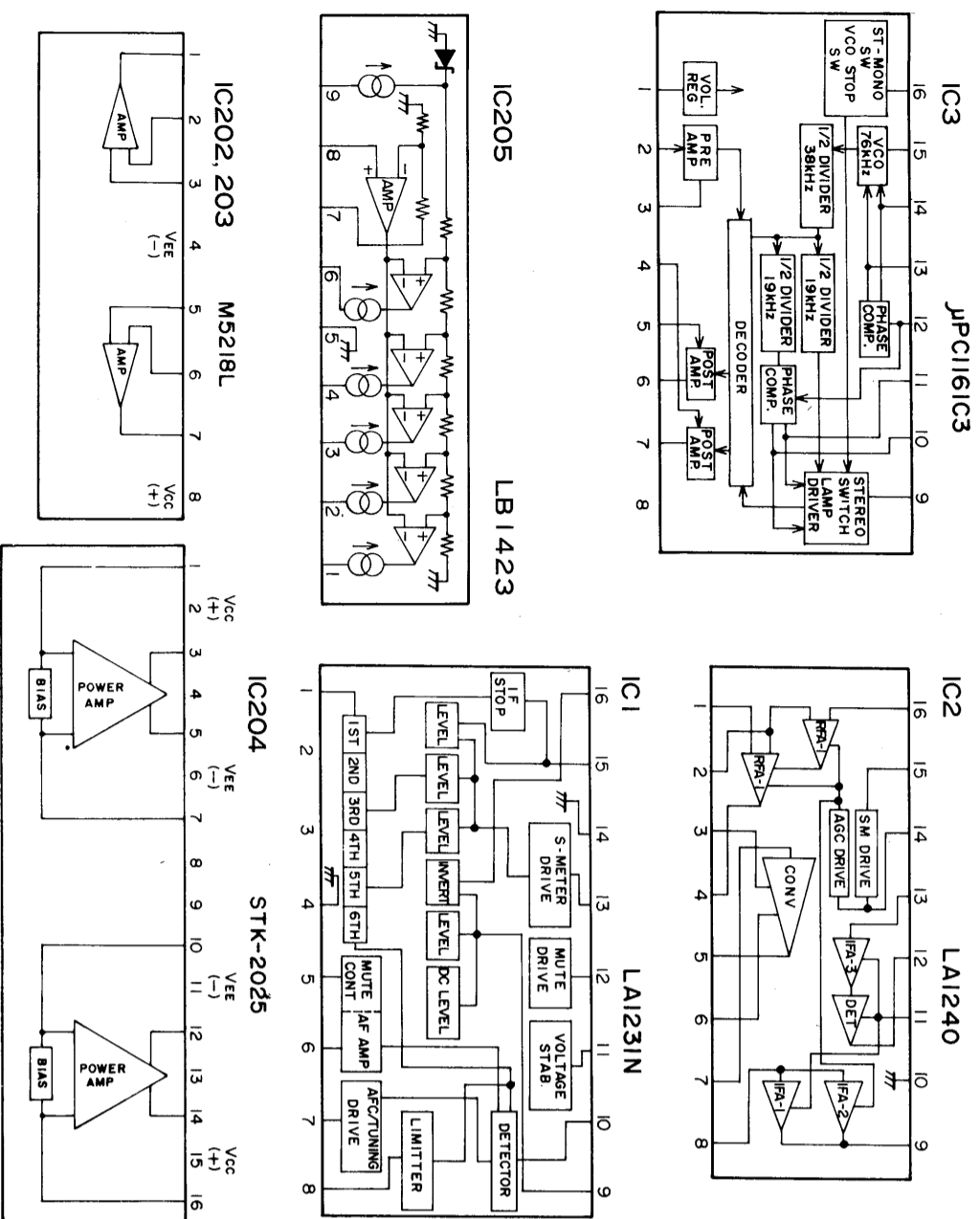

DIAL CORD STRINGING

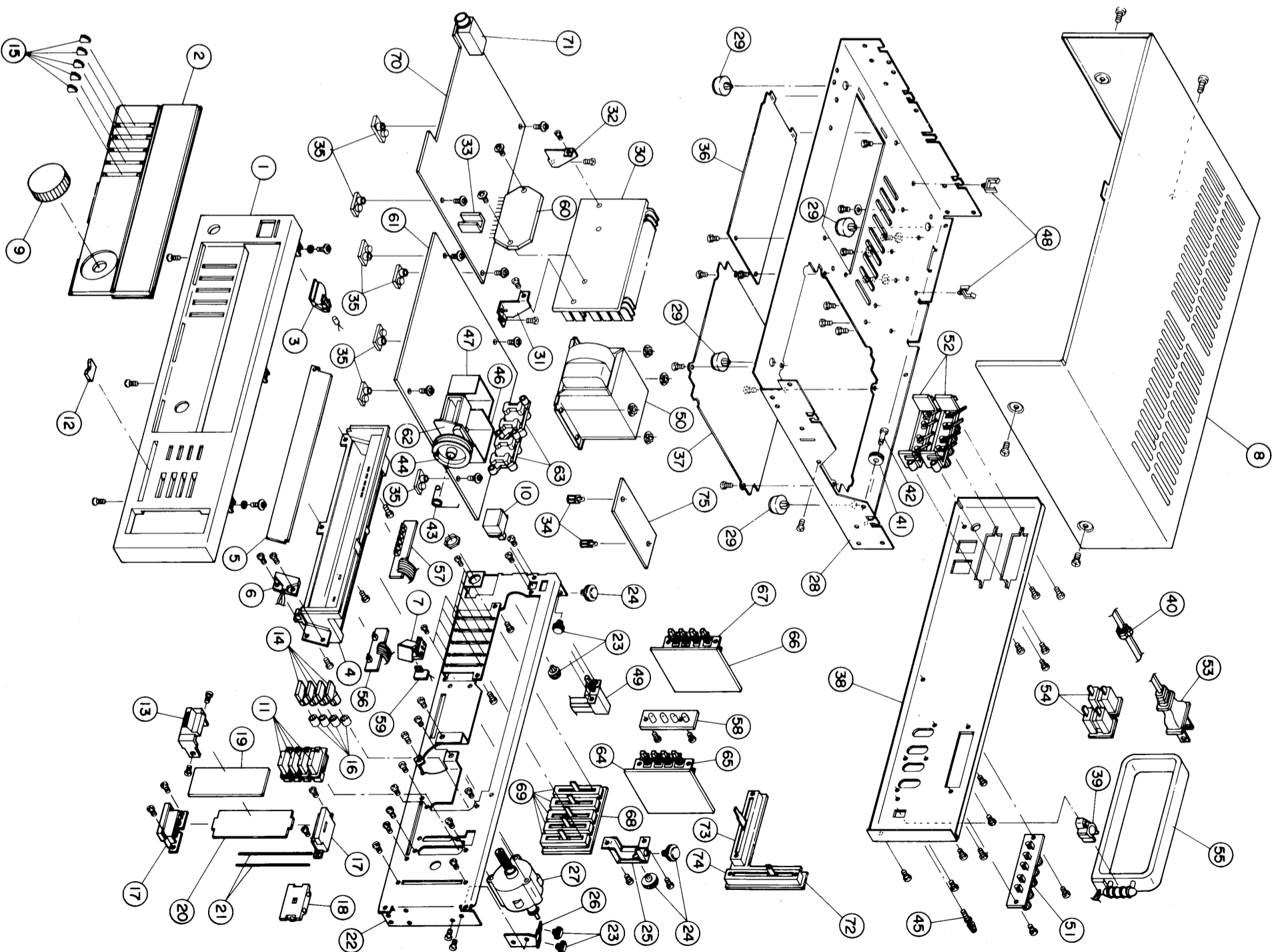
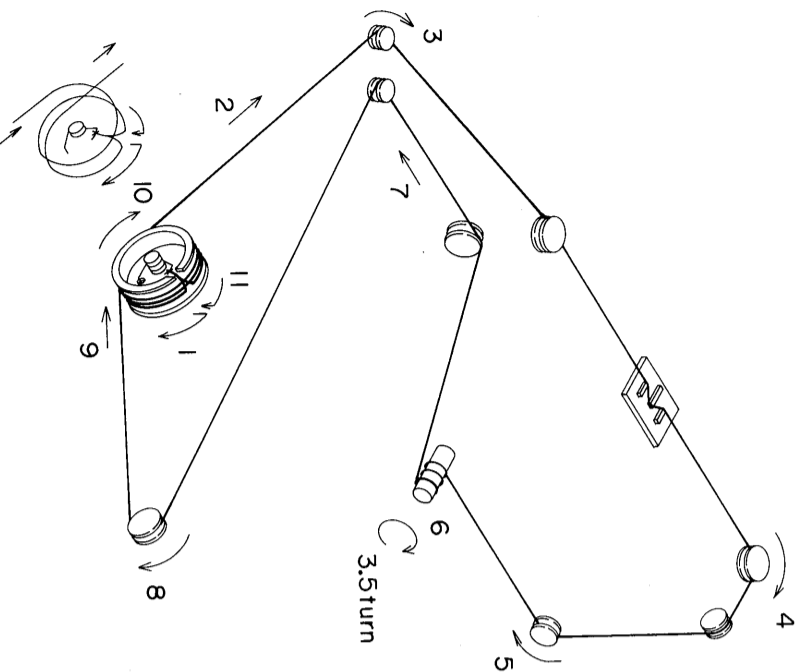

PARTS LIST

Key No.	Ref. No.	Part No.	Description	Q'ty
PACKAGE PARTS				
		R-4771705	Label, Date	1
		R-4773857	Label, UL	1
		R-4771704	Tag, AC cord	1
		R-357556	Polyethylene bag, AC cord	1
		R-357621	Polyethylene bag, Loop antenna	1
		R-357677	Polyethylene bag, Set	1
		R-4776659	Instruction manual	1
		R-4776292	Guarantee card	1
		R-4776647	Post card	1
		R-4773709A	Address book	1
		R-357562-1	Polyethylene bag, Instruction book	1
		R-4174399	Styro-foam cushion, Set front	1
		R-4174400	Styro-foam cushion, Set rear	1
		R-4076398	Individual carton	1
		R-4771702-4	Label, Control tag	1
		R-4775005	Attention sheet	1
ACCESSORY PARTS				
		R-S37175	External antenna	1
CABINET APPEARANCE PARTS				
1		R-317830	Panel, Front	1
2		R-3870468	Dial cover	1
3		R-3870469	Lamp cover	1
			Tap. Screw, Bind Hd., B-tight, 3×6	2
4		R-A78040	Bracket assembly, Dial scale	1
			Tap. Screw, Bind Hd., B-tight, 3×8	3
5		R-3870482	Dial scale	1
			Tap. Screw, Bind Hd., B-tight, 2.6×6	1
6		R-3974147A	Lamp holder	1
7		R-3975284	Pointer	1
8		R-A78041	Top lid assembly	1
			Screw, Washer Hd., S-tight, 4×6	4
9		R-3975285	Knob, TUNING	1
10		R-3975314	Knob, POWER	1
11		R-A78029	Knob assembly, FUNCTION	4
12		R-3975310	Knob, BALANCE	1
13		R-3975280	Knob, VOLUME	1
14		R-3975293	Knob, MONITOR/MONO/SP/LOUDNESS	4
15		R-3975326	Knob, EQ	5
16		R-4171489	Cushion, MONITOR/MONO/SP/LOUDNESS knob	4
17		R-3975282	Bracket, Main volume	2
			Tap. Screw, Bind Hd., B-tight, 3×6	4
18		R-3975283	Slide	1
			Tap. Screw, Flat Hd., B-tight, 3×8	2
19		R-3870474	Sign window	1
20		R-1274202	Bracket window	1
21		R-1571712	Shaft	2
CHASSIS MECHANICAL PARTS				
22		R-1274193	Chassis, Front	1
			Tap. Screw, Washer Hd., B-tight, 3×8	3
			Washer, External tooth lock, 3×6.5×0.45	3
			Tap. Screw, Bind Hd., B-tight, 3×8	3
			Screw, Pan Hd., 3×4	4
23		R-S872360	Pulley assembly, φ6	4
24		R-S872357	Pulley assembly, φ12	3
25		R-1274155	Bracket, Pulley	1
			Tap. Screw, Bind Hd., B-tight, 3×6	2
26		R-1274217	Bracket, Pulley	1
			Tap. Screw, Bind Hd., B-tight, 3×6	2
27		R-S872507	Fly wheel assembly	1

Key No.	Ref. No.	Part No.	Description	Q'ty
CHASSIS MECHANICAL PARTS				
			Tap. Screw, Bind Hd., B-tight, 3×10	3
28		R-1274197	Bottom lid	1
			Tap. Screw, Oval Hd., B-tight, 3×8	3
			Tap. Screw, Bind Hd., B-tight, 3×6	14
29		R-S872604	Foot base assembly	4
30		R-277616-3	Heat sink	1
			Tap. Screw, Bind Hd., B-tight, 3×8	2
31		R-1272140A	Bracket, Heat sink mtg.	1
			Tap. Screw, Bind Hd., S-tight, 3×5	1
32		R-1272141A	Bracket, Heat sink mtg.	1
33		R-2672904A	Heat sink, Amp. P. C. B.	1
			Screw, Washer Hd., B-tight, 3×8	1
34		R-377095	Clip, Fuse P. C. B.	2
			Tap. Screw, Pan Hd., 3.5×6	2
35		R-327491	Bracket, P. C. B. mtg.	7
			Tap. Screw, Bind Hd., B-tight, 3×8	7
			Tap. Screw, Washer Hd., B-tight, 3×8	7
36		R-1274116	Bottom lid, Amp.	1
			Tap. Screw, Pan Hd., B-tight, 3×6	2
37		R-1274269	Bottom lid, Tuner	1
			Tap. Screw, Pan Hd., B-tight, 3×6	4
		R-4775610-1	Label, Bottom lid	2
38		R-A78042	Chassis assembly, Rear	1
39		R-377150	Holder, Loop antenna	1
40		R-357035	Nylon bushing, AC cord	1
41		R-357398	Pulley	1
42		R-147054-2	Pulley shaft	1
			Dial cord string, φ0.5×	1
43		R-1571481A	Spring, Drum	1
44		R-S872706	Drum assembly	1
45		R-1570437	Earth terminal	1
			Flat washer, Metal, 3×8×0.5	1
46		R-1272886A	Shield case, Tuner P. C. B.	1
47		R-1274132	Shield case, Tuner P. C. B.	1
		R-1274046	Shield plate, Tuner P. C. B. bottom	1
48		R-377120	Wire holder	2
CHASSIS ELECTRICAL PARTS				
49	S1	△ R-S47898	Push switch, POWER	1
			Screw, Pan Hd., 3×4	2
50	PT1	△ R-W770255	Power transformer	1
			Screw, Pan Hd., With flat washer, 4×10	4
			Nut, Hex Hd., 4	4
51	JK1	R-S17589	Terminal plate, ANTENNA	1
			Tap. Screw, Pan Hd., B-tight, 3×8	2
52	JK3, 4	R-S17588	Terminal plate, SPEAKERS	2
			Tap. Screw, Pan Hd., B-tight, 3×8	4
			Cord fixer	6
		R-S17243	Wire tie	10
		R-S17399	Pilot lamp	1
	PL1	△ R-S17580	Pilot lamp	1
	PL2	△ R-S17581	Pilot lamp	1
		△ R-S37224	AC cord	1
53		△ R-S27402	Socket	2
54		△ R-S37108-6	Housing, 6P	1
	CS9	R-257265	Terminal	6
55	L5	R-W27182	Loop antenna	1
	CP1	R-S37419-28	PC joiner	1
	CP2	R-S37417-24	PC joiner	1
	CP3, 4, 6, 11	R-S37413-24	PC joiner	4
	CP5, 7	R-S37413-10	PC joiner	2
	CP10, 15	R-S37414-13	PC joiner	2
	CP12	R-S37413-14	PC joiner	1
	CP8	R-S37415-13	PC joiner	1
	CP13	R-S37415-8	PC joiner	1
	CP14	R-S37410-7	PC joiner	1
		R-S37416-7	PC joiner	1

- NOTES : 1. Part orders must contain Model Number, Part Number and Description.
 2. Ordering quantity of screws and/or resistors must be multiple of 10 pcs.

PARTS LIST (CONTINUED)

Key No.	Ref. No.	Part No.	Description	Q'ty
CHASSIS ELECTRICAL PARTS				
	CP16	R-S37416-16	PC joiner	1
		R-237113	Lug	2
		R-257277	Terminal	5
56	R1	R-R7740	Resistors, 1.8 Mohm	1
57		R-4174358-2	Printed circuit, STEREO IND.	1
58		R-4174358-3	Printed circuit, SIGNAL IND.	1
59		R-4174359-2	Printed circuit, FUNCTION IND.	1
		R-4173574	Printed circuit, POINTER	1
SEMICONDUCTORS				
60	IC204		IC, STK2025	1
	D202		LED, SLP-151B, POINTER	1
	D211		LED, SLP-151B, STEREO IND.	1
	D212		LED, SLP-251B, STEREO IND.	1
	D221~225		LED, SLP-152B, SIGNAL IND.	1
	D231~234		LED, SLP-135B, FUNCTION IND.	4
TUNER P. C. B. ASSEMBLY				
61		R-A78043	Circuit board assembly, Tuner	1
62	CV1~5	R-C1739-1	Variable capacitor	1
	CT1, 2			
	L1	R-W9731	VHF coil	1
	L2	R-W9733	VHF coil	1
	L3	R-W9747	VHF coil	1
	L4	R-W9724	Choke coil	1
	L6	R-W27187	Antenna coil	1
	L7	R-W87044	OSC coil	1
	L8, 9	R-M1705	Filter coil	2
	T1	R-W5T766	IF transformer	1
	T2	R-W5T7049	IF transformer	1
	T3	R-W5T7007-1	IF transformer	1
	T4	R-W4722	Filter coil	1
	CF1, 2	R-S17350	Ceramic filter	2
	CF3	R-S17333	Ceramic filter	1
	CT3	R-C0716	Trimmer	1
	CT4, 5	R-C0740	Trimmer	2
	SVR1,2,3	R-R110705	Preset resistor, 50 k	3
	SVR4	R-R110724	Preset resistor, 10 k	1
	SVR5	R-R110736	Preset resistor, 250 k	1
63	JK2	R-S17514	Terminal plate, PHONO/AUX/ TAPE	2
		R-237188	Lug	1
SEMICONDUCTORS				
	IC1		IC, LA1231N	1
	IC2		IC, LA1240	1
	IC3		IC, μ PC1161C3	1
	IC201		Ope Amp., M5218L	1
	Q1, 6		Transistor, 2SK315	2
	Q2, 4		Transistor, 2SC930	2
	Q3		Transistor, 2SC2999	1
	Q5		Transistor, 2SC536	1
	D1, 3, 4, 5		Diode, DS442	4
	D2		Diode, 1S188 AM	1
RESISTORS				
(Resistors are of carbon type, $\pm 5\%$ allowance and $\frac{1}{4}$ W unless otherwise noted.)				
	R5		220 k ohm	1
	R6		33 ohm	1
	R7		330 ohm	1
	R8, 24		220 ohm	2
	R9, 15, 19		15 k ohm	3
	R32, 36, 81, 82, 201, 301		2.2 k ohm	6
	R11, 33, 53, 56, 76		8.2 k ohm	5
	R13		4.7 k ohm	1
	R12		33 k ohm	1
	R14, 20, 58, 69, 70, 204, 207, 304, 307		1 k ohm	9
	R16		150 ohm	1
	R17, 21, 26		390 ohm	3
	R18, 67, 68		3.3 k ohm	3

Key No.	Ref. No.	Part No.	Description	Q'ty
TUNER P. C. B. ASSEMBLY				
	R10		2.7 k ohm	1
	R29, 39, 50, 55, 202, 203, 302, 303		100 k ohm	8
	R27, 34, 60, 63, 64, 205, 305		47 k ohm	7
	R28, 46, 47, 57, 65, 66		10 k ohm	6
	R35		12 k ohm	1
	R38, 54		27 k ohm	2
	R41		560 ohm	1
	R42		1.5 k ohm	1
	R43		470 ohm	1
	R30, 45		5.6 k ohm	2
	R48, 74		100 ohm	2
	R49		18 k ohm	1
	R59, 73		1.8 k ohm	2
	R61, 62		22 k ohm	2
	R71, 72		6.8 k ohm	2
	R206, 306		560 k ohm	2
	R208, 308		56 k ohm	2
	R40		Solid, 3.3 k ohm, $\pm 10\%$, $\frac{1}{2}$ W	1
	R44		Solid, 470 ohm, $\pm 10\%$, $\frac{1}{2}$ W	1
	R51		Solid, 330 ohm, $\pm 10\%$, $\frac{1}{2}$ W	1
	R25, 52, 251, 252		Metal oxide film, 220 ohm, $\pm 5\%$, 1W	4
	R37		Metal oxide film, 120 ohm, $\pm 5\%$, 1W	1
CAPACITORS				
	C5		Ceramic, 10pF, $\pm 5\%$, 50V, SL	1
	C6, 33, 54		Ceramic, 100pF, $\pm 5\%$, 50V, SL	3
	C7, 55		Ceramic, 18pF, $\pm 5\%$, 50V, SL	2
	C8		Ceramic, 4.7pF, $\pm 10\%$, 50V, SL	1
	C9		Ceramic, 1.5pF, $\pm 20\%$, 50V, SL	1
	C16		Ceramic, 20pF, $\pm 5\%$, 50V, SL	1
	C62		Ceramic, 33pF, $\pm 5\%$, 50V, SL	1
	C74		Ceramic, 120pF, $\pm 5\%$, 50V, SL	1
	C10		Ceramic, 24pF, $\pm 5\%$, 50V, P	1
	C11		Ceramic, 10pF, $\pm 5\%$, 50V, C	1
	C12		Ceramic, 30pF, $\pm 5\%$, 50V, C	1
	C13		Ceramic, 24pF, $\pm 5\%$, 50V, C	1
	C17, 56, 71		Ceramic, 560pF, $\pm 10\%$, 50V, B	3
	C75, 76		Ceramic, 0.0012 mfd, $\pm 10\%$, 50V, B	2
	C14, 15, 18, 20, 21, 22, 23, 26, 27, 28, 29, 30, 32, 57, 58, 60, 61, 65, 66, 68		Ceramic, 0.022 mfd, $\pm 30\%$, 16V	20
	C24		Ceramic, 0.022 mfd, +80 -20%, 50V, Z	1
	C25		Ceramic, 0.04 mfd, +80 -20%, 50V, Z	1
	C59, 67		Ceramic, 0.01 mfd, $\pm 10\%$, 25V, X	2
	C77, 78		Ceramic, 0.0039 mfd, $\pm 10\%$, 25V, X	2
	C64		Ceramic, 24pF, $\pm 5\%$, 50V, V	1
	C69, 70		Ceramic, 0.0033 mfd, $\pm 10\%$, 50V, V	2
	C73		Styrol, 510pF, $\pm 5\%$, 50V	1
	C63		Styrol, 360pF, $\pm 5\%$, 50V	1
	C72		Mylar, 0.047 mfd, $\pm 10\%$, 50V	1
	C203, 303		Mylar, 0.0015 mfd, $\pm 10\%$, 50V	2
	C204, 304		Mylar, 0.0056 mfd, $\pm 10\%$, 50V	2
	C51		Electrolytic, 0.1 mfd/50V	1
	C37, 41, 44, 79, 83, 84		Electrolytic, 10 mfd/16V	6
	C38, 42, 45, 46, 52		Electrolytic, 1 mfd/50V	5
	C39		Electrolytic, 0.47 mfd/50V	1
	C40		Electrolytic, 220 mfd/16V	1
	C47, 201, 301		Electrolytic, 4.7 mfd/16V	3
	C48, 85, 86, 205, 305		Electrolytic, 3.3 mfd/25V	5
	C49, 50*		Electrolytic, 47 mfd/16V	2
	C87		Electrolytic, 330 mfd/16V	1
	C80		Electrolytic, 0.22 mfd/50V	1
	C81		Electrolytic, 3.3 mfd/50V	1
	C82		Electrolytic, 1 mfd/50V	1
	C202, 302		Electrolytic, 100 mfd/10V	2
	C251, 252		Electrolytic, 33 mfd/16V	2

NOTES : 1. Part orders must contain Model Number, Part Number and Description.
2. Ordering quantity of screws and/or resistors must be multiple of 10 pcs.

PARTS LIST (CONTINUED)

Key No.	Ref. No.	Part No.	Description	Q'ty
FUNCTION P. C. B. ASSEMBLY				
64		R-A78044	Circuit board assembly, Function	1
65	S2-1~4	R-S47927	Push switch, AM/FM/PHONO/AUX	1
	CS1	R-S27632-9	Socket, 9P	1
	CS2	R-S27632-7	Socket, 7P	1
	CS3	R-S27632-3	Socket, 3P	1
RESISTORS				
(Resistors are of carbon type, ±5% allowance and ¼W unless otherwise noted.)				
	R270		1.8 k ohm	1
SP SELECTION P. C. B. ASSEMBLY				
66		R-A78045	Circuit board assembly, SP SELECTION	1
67	S3, 4, 5, 6	R-S47928	Push switch, TAPE MONITOR/MODE/LOUDNESS/SPEAKERS	1
	CS4, 6, 10, 12	R-S27632-13	Socket, 13P	1
	CS8	R-S27632-5	Socket, 5P	1
	CP9	R-S27531-6	Plug, 6P	1
RESISTORS				
(Resistors are of carbon type, ±5% allowance and ¼W unless otherwise noted.)				
	R280, 380		330 k ohm	2
	R281, 381		8.2 k ohm	2
CAPACITORS				
	C280, 380		Ceramic, 220pF, ±10%, 50V, B	2
GEQ VR P. C. B. ASSEMBLY				
68		R-A78046	Circuit board assembly, GEQ VR	1
69	VR201~205, 301~305	R-R130736	Slide VR, 250 k-W	5
AMP. P. C. B. ASSEMBLY				
70		R-A78047	Circuit board assembly, Amp.	1
71	F201, 301 Δ	R-S27438-2	Headphone jack	1
		R-S17592	Fuse, 2.5A	2
		R-237030	Fuse, clip	4
	CS15	R-S27440-13	Socket, 13P	1
	CS16	R-S27440-6	Socket, 6P	1
	CS14	R-S27440-16	Socket, 16P	1
	CS5,7,11	R-S27632-3	Socket, 3P	3
SEMICONDUCTORS				
	IC202, 203		Ope Amp., M5218L	2
	IC205		IC, LB1423	1
	Q201, 301		Transistor, 2SA798	2
	Q202, 302		Transistor, 2SC2363	2
	Q210~214, 310~314		Transistor, 2SC536	10
	Q250	Δ	Transistor, 2SD600	1
	Q251		Transistor, 2SA608	1
	D201, 301		Diode, DS442	2
	D251, 252	Δ	Zener diode, GZA15Z	2
	D253~256	Δ	Diode, S2V20	4
RESISTORS				
(Resistors are of carbon type, ±5% allowance and ¼W unless otherwise noted.)				
	R210, 217, 310, 317		2.2 k ohm	4
	R211, 311		220 k ohm	2
	R212, 231, 244, 312, 331, 344		39k ohm	6
	R214, 218, 314, 318		4.7 k ohm	4
	R215, 216, 223, 315, 316, 323		100 k ohm	6
	R220, 224, 228, 232, 236, 320, 324, 328, 332, 336		390 ohm	10
	R222, 226, 230, 234, 238, 239, 322, 326, 330, 334, 338, 339		1.5 k ohm	12
	R221, 225, 229, 233, 237, 321, 325, 329, 333, 337		5.6 k ohm	10
	R219, 319		150 k ohm	2

Key No.	Ref. No.	Part No.	Description	Q'ty
AMP. P. C. B. ASSEMBLY				
		R213, 235, 313, 335	22 k ohm	4
		R227, 250, 327, 350	56 k ohm	4
		R240, 340	1.2 k ohm	2
		R241, 341	12 k ohm	2
		R243, 343	2.7 k ohm	2
		R245, 246, 345, 346	3.3 k ohm	4
		R264, 268	10 k ohm	2
		R265, 266, 267	1 k ohm	3
		R242, 342	Metal oxide film, 1.5 k ohm, ±5%, 1W	2
		R247, 347	Metal oxide film, 10 ohm, ±5%, 1W	2
		R248, 348	Metal oxide film, 270 ohm, ±5%, 1W	2
		R262	Metal oxide film, 2.2 k ohm, ±5%, 1W	1
		R263	Metal oxide film, 470 ohm, ±5%, 1W	1
		R269	Metal oxide film, 220 ohm, ±5%, 1W	1
		R260	Fuse, 10 ohm, ±5%, ½W	1
		R261	Fuse, 100 ohm, ±5%, ½W	1
CAPACITORS				
		C241, 341, 250~254	Ceramic, 0.04 mfd, +80 -20%, 50V, Z	7
		C211, 236, 311, 336	Ceramic, 100pF, ±5%, 50V, SL	4
		C213, 313	Ceramic, 10pF, ±5%, 50V, SL	2
		C244, 344	Ceramic, 15pF, ±5%, 50V, SL	2
		C215, 231, 315, 331	Ceramic, 470pF, ±10%, 50V, B	4
		C229, 329	Ceramic, 270pF, ±10%, 50V, B	2
		C228, 328	Ceramic, 680pF, ±10%, 50V, B	2
		C233, 333	Ceramic, 2pF, ±0.25pF, 50V, SL	2
		C234, 334	Ceramic, 12pF, ±5%, 50V, SL	2
		C237, 337	Ceramic, 100pF, ±5%, 50V, SL	2
		C223, 323	Mylar, 0.082 mfd, ±10%, 50V	2
		C281, 381	Mylar, 0.027 mfd, ±10%, 50V	2
		C220, 320	SBL ceramic, 0.018 mfd, ±10%, 25V	2
		C222, 322	SBL ceramic, 0.0082 mfd, ±10%, 25V	2
		C224, 324	SBL ceramic, 0.0033 mfd, ±10%, 25V	2
		C225, 325	SBL ceramic, 0.022 mfd, ±10%, 25V	2
		C226, 326	SBL ceramic, 0.001 mfd, ±10%, 25V	2
		C227, 327	SBL ceramic, 0.0047 mfd, ±10%, 25V	2
		C210, 216, 310, 316	Electrolytic, 4.7 mfd/25V	4
		C212, 312	Electrolytic, 100 mfd/10V	2
		C214, 230, 314, 330	Electrolytic, 2.2 mfd/50V	4
		C217, 242, 256, 317, 342	Electrolytic, 10 mfd/16V	4
		C218, 318	Electrolytic, 47 mfd/16V	2
		C219, 319	Electrolytic, 3.3 mfd/50V	2
		C221, 321	Electrolytic, 0.33 mfd/50V	2
		C232, 332	Electrolytic, 220 mfd/6.3V	2
		C235, 240, 335, 340	Electrolytic, 100 mfd/25V	4
		C238, 338	Electrolytic, 47 mfd/35V	2
		C255	Electrolytic, 100 mfd/35V	1
		C239, 339	Electrolytic, 4700 mfd/35V	2
		C243, 343	Mylar, 0.047 mfd, ±20%, 50V	2
VR. P. C. B. ASSEMBLY				
72		R-A78048	Circuit board assembly, VR	1
73	VR1, 2	R-R145736	Slide VR, 250 k-MN, BALANCE	1
74	VR3, 4	R-R160719	Slide VR, 100 k-A×2, VOLUME	1
FUSE P. C. B. ASSEMBLY				
75		R-A78049	Circuit board assembly, Fuse	1
		R-237030	Fuse clip	2
		R-S17306-2	Fuse, 3A	1
	F1 Δ	R-C97019	} or Capacitor, 0.01 mfd, 125V	1
	C1	R-C97009		
		R-237188	Lug	2
		R-377095	Clip	4

NOTES : 1. Part orders must contain Model Number, Part Number and Description.
 2. Ordering quantity of screws and/or resistors must be multiple of 10 pcs.



FISHER CORPORATION 21314 LASSEN STREET · CHATSWORTH · CALIF. 91311

'82/May/3000 SO
PRINTED IN JAPAN
WM-7805