

SERVICE MANUAL

FISHER

RS-270

**AM/FM STEREO
QUARTZ LOCKED DIGITAL
SYNTHESIZER RECEIVER
(EUROPE)**

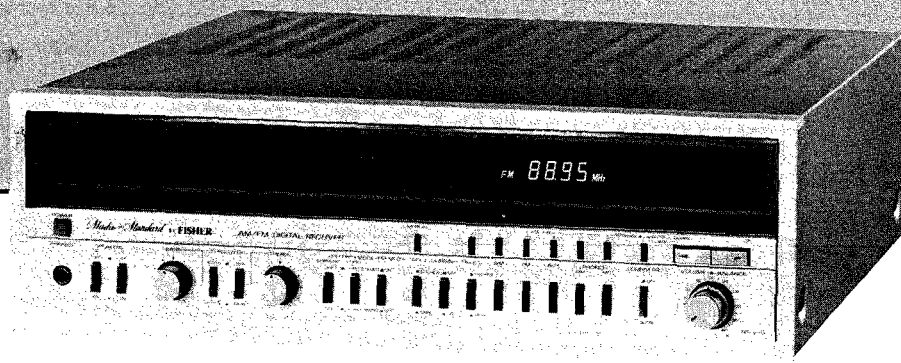

NOTE:

The phono on the cover shows the unit with a "BRUSHED ALUMINUM" front panel. The "BLACK" version is identical in all respects.

The first name in high fidelity

SPECIFICATIONS (Continued)

AM SECTION		
Tuning Range		522 – 1602 kHz
Sensitivity		300 μ V/m
S/N Ratio		55 dB
Image Rejection		50 dB
Selectivity (\pm 10 kHz)		40 dB
THD (30 % Mod.)		0.3 %
Spurious Rejection		55 dB
IF Rejection		45 dB
AMPLIFIER SECTION		
Sine Wave Power	at 1,000 Hz (8 ohms)	2 x 62 W
	20 to 20,000 (8 ohms)	2 x 50 W
Music Power (8 ohms)		2 x 70 W
THD (Rated Output, 8 ohms)		0.02 %
IM (Rated Output, 8 ohms)		0.02 %
Damping Factor (8 ohms)		> 50
Frequency Response (20 Hz – 20 kHz)		\pm 0.5 dB
Input Sensitivity and Impedance	Phono MC	60 μ V/22 ohms
	Phono MM	2.5 mV/50 kohms
	Tape	150 mV/50 kohms
	Aux	150 mV/50 kohms
S/N Ratio (DIN)	Phono	80 dB
	Tape/Aux	100 dB
Treble Control 10 kHz (Turn-over 3 kHz)		\pm 10 dB
Bass control 100 Hz (Turn-over 400 Hz)		\pm 10 dB
Loudness Control (100 Hz/10 kHz)		+8 dB/+4 dB
GENERAL		
Power Requirements		AC: 110/220 V, 50 Hz
Power Consumption		260 W
Dimensions (W x D x H)		440 x 400 x 132 mm
Weight (approx.)		11.5 kg

Because its products are subject to continuous improvement, Fisher Corporation reserves the right to modify product designs and specifications without notice and without incurring any obligation.

FUNCTIONAL BLOCK DIAGRAM

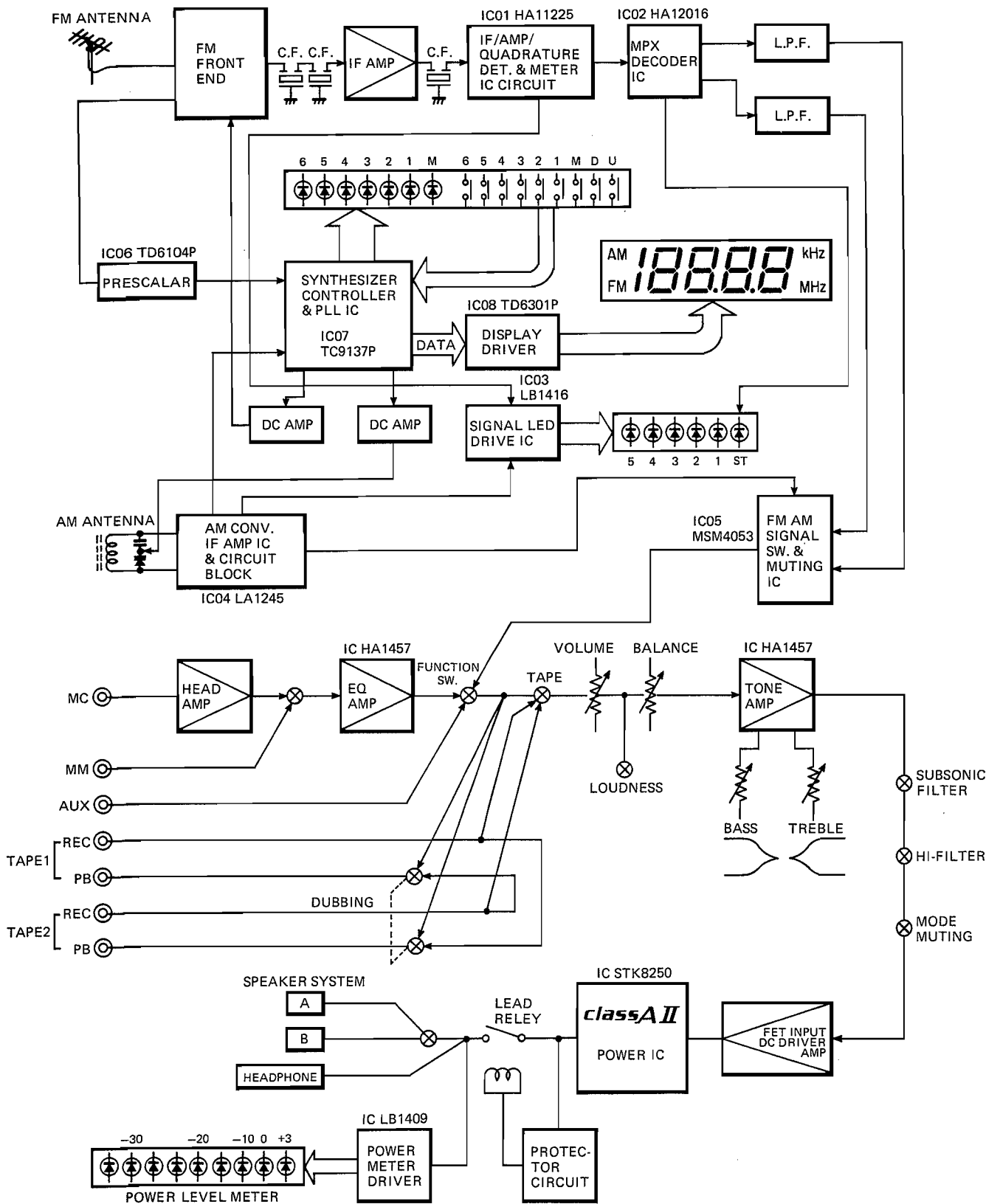

CABINET & CHASSIS EXPLODED VIEW

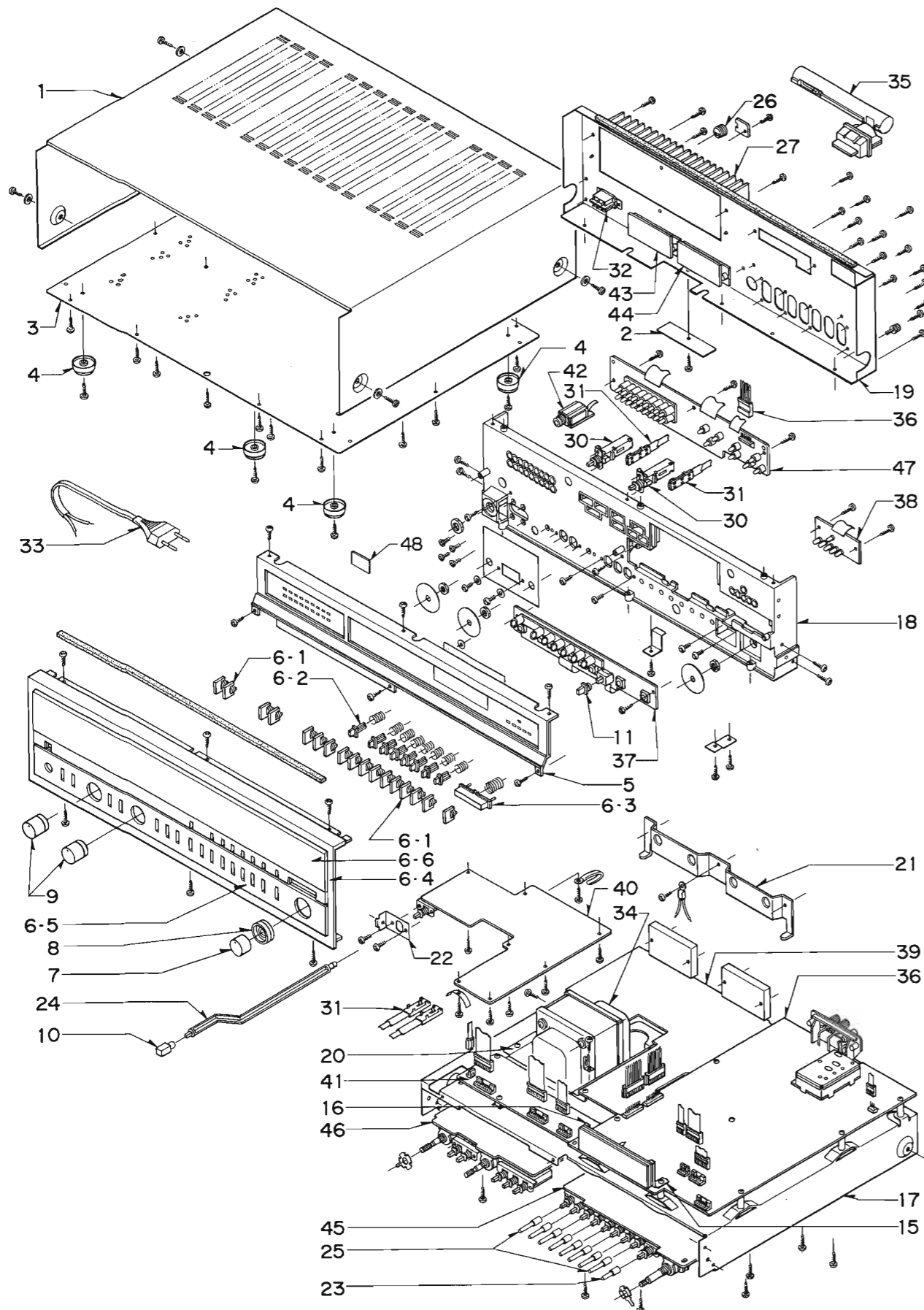

PARTS LIST

PACKING PARTS LIST

Ref. No.	Parts Number	Description
	131 6 1139 85902	Box Corrugate-EXP
	131 6 2119 02121	Bag Polyethylene-EXP
	131 6 3009 31260	Pad, (Right)
	131 6 3009 31270	Pad, (Left)

ACCESSORIES PARTS LIST

Ref. No.	Parts Number	Description
	131 6 2719 10801	Bag Fan
	131 6 4119 85208	Explanatory Booklet
	131 6 4159 35800	Notes
	131 6 4519 15700	Guarantee Certificate

CABINET PARTS LIST

Ref. No.	Parts Number	Description
1	131 2 1410 24401	Cover
2	131 2 1410 25000	Cover
3	131 2 1105 26500	Plate Bottom
4	131 2 1801 12900	Leg

APPEARANCE PARTS LIST

Ref. No.	Parts Number	Description
5	131 0 1008 13200	Plate Dial Assy
6	131 0 1016 36707	Panel Decorate Assy (Silver)
	131 0 1016 36706	Panel Decorate Assy (Black)
6-1	131 0 1001 58203	Push Switch Knob (Silver)
	131 0 1001 58202	Push Switch Knob (Black)
6-2	131 0 1001 58303	Push Switch Knob (Silver)
	131 0 1001 58302	Push Switch Knob (Black)
6-3	131 0 1001 58403	Tuning Switch Knob (Silver)
	131 0 1001 58402	Tuning Switch Knob (Black)
6-4	131 2 1203 49701	Panel Control (Silver)
	131 2 1203 49700	Panel Control (Black)
6-5	131 2 1203 49803	Panel Control (Silver)
	131 2 1203 49802	Panel Control (Black)
6-6	131 2 1205 24800	Decorate Plate Dial
7	131 0 1001 56901	Upper Volume Knob (Silver)
	131 0 1001 56900	Upper Volume Knob (Black)
8	131 0 1001 57001	Under Volume Knob (Silver)
	131 0 1001 57000	Under Volume Knob (Black)
9	131 0 1001 57101	Tone Knob (Silver)
	131 0 1001 57100	Tone Knob (Black)
10	131 2 1601 64100	Knob (Power Switch)
11	131 2 1601 65800	Knob (Push Switch)

CHASSIS PARTS LIST

Ref. No.	Parts Number	Description
15	131 2 3101 73100	Metal Mount
16	131 2 3101 74300	Metal Mount
17	* 131 2 3301 27300	Chassis
18	* 131 2 3305 29800	Panel Front
19	* 131 2 3306 32102	Panel Rear
20	131 2 3617 18200	Metal Mount Transformer
21	131 2 3701 27800	Mount E Parts
22	131 2 3701 27900	Mount E Parts
23	131 2 4121 00700	Coupling (Push Switch)
24	131 2 4121 00800	Coupling (Power Switch)
25	131 2 4121 00900	Coupling (Push Switch)
26	131 2 6111 14200	Bushing (AC Cord)
27	131 2 6201 28901	Plate Heat Sink (Panel Rear)

ELECTRICAL PARTS LIST

Ref. No.	Parts Number	Description
30	△ 4 2312 03680	Switch, Push
31	4 2312 03682	Joint Switch
32	△ 4 2312 01020	Switch Slide
33	△ 4 2432 00071	Power Cord
34	△ 4 2512 13020	Power Transformer
35	4 2579 25260	Bar Antenna AM
36	* 131 0 4001 05731	RF Control P.C.B. Assy
37	* 131 0 4001 05740	Switch P.C.B. Assy
38	* 131 0 4001 05750	Signal P.C.B. Assy
39	* 131 0 4001 05641	Power Amp P.C.B. Assy
40	* 131 0 4001 05652	Power Supply P.C.B. Assy
41	* 131 0 4001 05661	L.E.D. Drive P.C.B. Assy
42	* 131 0 4001 05671	Headphone Jack P.C.B. Assy
43	* 131 0 4001 05681	SP Terminal 1 P.C.B. Assy
44	* 131 0 4001 05691	SP Terminal 2 P.C.B. Assy
45	* 131 0 4001 05700	Phono EQ P.C.B. Assy
46	* 131 0 4001 05710	Tone Amp P.C.B. Assy
47	* 131 0 4001 05720	L.E.D. Lamp P.C.B. Assy
48	* 131 0 4001 06611	Power Ind. P.C.B. Assy
R01,02	R2HCPK185A	Solid 1.8 M 1/2W ±10%

*—Not a service part.

PRODUCT SAFETY NOTICE

PRODUCT SAFETY SHOULD BE CONSIDERED WHEN A COMPONENT REPLACEMENT IS MADE IN ANY AREA OF AN UNIT. COMPONENTS INDICATED BY A MARK △ IN THIS PARTS LIST AND THE SCHEMATIC DIAGRAM SHOW COMPONENTS WHOSE VALUE HAS SPECIAL SIGNIFICANCE TO PRODUCT SAFETY. IT IS PARTICULARLY RECOMMENDED THAT ONLY PARTS SPECIFIED ON THE FOLLOWING PARTS LIST BE USED FOR COMPONENT REPLACEMENT POINTED OUT BY THE MARK.

SEMICONDUCTOR LEAD IDENTIFICATION

INTEGRATED CIRCUITS

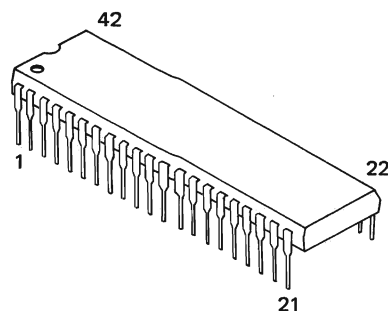

• TC9137P

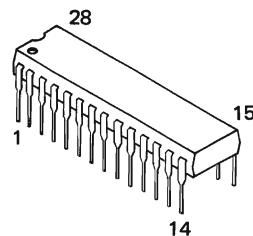

• TD6301P

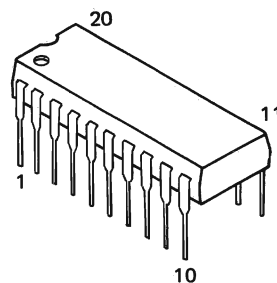

• LA1245

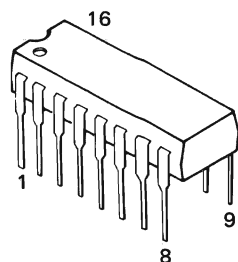

• HA11225
• HA12016
• LB1409
• MSM4053

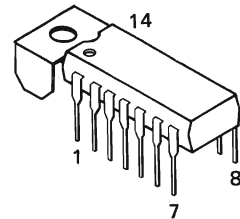

• LB1416

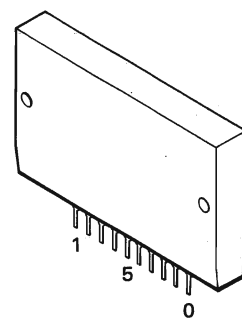

• STK8250

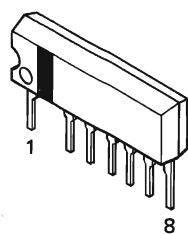

• HA1457

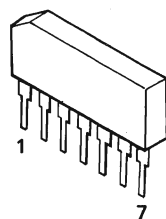

• TD6104P

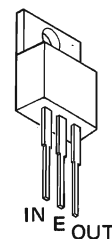

• FS-7812M

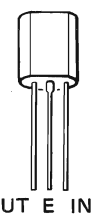

• TA78L024

SEMICONDUCTOR LEAD IDENTIFICATION (Continued)

TRANSISTORS

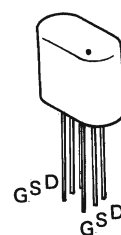

• 2SK185



• 2SD794



• 2SB560
• 2SD400
• 2SD438
• 2SC2375
• 2SA1019



• 2SB544
• 2SC536
• 2SC930
• 2SC1000
• 2SC1570
• 2SC2274
• 2SD734



• 2SA978
• 2SC2385



• 2SK30A



• 2SK104

DIODES

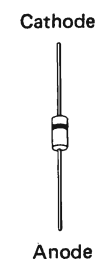

• DS-135
• DS-442
• WZ-240
• RD4.3E
• RD5.6E
• RD7.5E
• GZA5.6L
• GZA6.2U
• GZA20U
• GZA24L

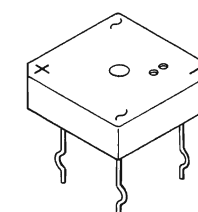

• DBA-60C

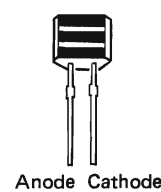

• SVC321

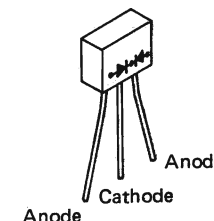

• DS-17
• DS131

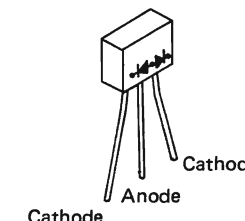

• DS-18

FM TUNER ALIGNMENT

FM ALIGNMENT – FUNCTION switch to FM, MUTING switch to OFF,
VOLUME control to minimum.

ITEM	GENERATOR	DIAL SETTING	INDICATOR	PROCEDURE
<p>NOTE: The FM IF circuit utilizes a non-turnable ceramic filter which establishes the IF bandpass. To insure symmetrical tuning and selectivity, the IF must be aligned precisely to the center of the filter bandpass, rather than to 10.7 MHz as in conventional LC circuits.</p>				
1. PRELIMINARY DETECTOR ALIGNMENT	Connect 10.7 MHz Sweep Generator to IF and, ground lead to chassis. Adjust for S-curve display. Set generator output to 60 dB.	Position of non-interference	Scope vertical input to Pin 3.	Adjust T01 for maximum gain and best linearity. Adjust T02 for minimum gain and best linearity. See Figure 3.
2. S-CURVE CENTER ALIGNMENT			Connect DC VTVM across Pin 5 and Pin 2.	Adjust VR07 until VTVM reads 0 V. See Figure 4.
3. FINAL DETECTOR ADJUSTMENT (MINIMUM T.H.D.)	Set generator to receiver frequency. Modulate with 400 Hz ± 75 kHz deviation. Connect generator to FM ANT terminals.	Same as above	Harmonic Distortion Analyzer to LEFT REC OUT Jack.	Adjust T02 for minimum distortion.
4. Repeat steps 1 ~ 3 until optimum alignment is reached.				
5. SIGNAL LED ADJUSTMENT	Connect FM RF generator through FM Dummy ANTENNA to FM ANTENNA terminals. Set generator to 98 MHz. (60 dB)	Set to 98 MHz.	Front Panel SIGNAL LED display	Adjust VR06 until the fifth signal-LED partly lights up.
<p>NOTE: Confirm that all signal LED light up brightly when the antenna input is increased to 100 dB. Then, set the input in no-signal mode and confirm that all LED are extinguished in all bands. Perform this adjustment after AM Signal LED Adjustment.</p>				
6. FM STOP LEVEL ADJUSTMENT	Set generator to 98 MHz. Adjust ATT output for $5\mu V$. (14 dB)	Same as above	Connect DC VTVM to Pin 8.	Adjust VR01 until VTVM reads 4 V.
7. PLL IC FREE RUN FREQ. CONT. ADJUSTMENT (76 kHz)	Set generator to 98 MHz.	Same as above	Connect frequency counter to Pin 6.	Adjust VR03 in multiplex circuit to obtain $76\text{ kHz} \pm 800\text{ Hz}$ on counter.
8. FM STEREO SIGNAL SEPARATION CONTROL	Connect FM stereo SG to FM ANT terminals. 19 kHz signal ON. Main channel, sub channel signal ON. Apply 100 Hz signal from LEFT channel.		Scope and AC-VTVM to RIGHT output jack.	Adjust VR02 for minimum output.
	Same as above for RIGHT channel.		Scope and AC-VTVM to LEFT output jack.	

RECOMMENDED TEST EQUIPMENTS

The following test equipment is recommended to completely test and align the tuner

- Line Voltage Isolation Transformer
- AC DC Multimeter.
- Accurately Calibrated AC Voltmeter
- Oscilloscope (Flat to 100 kHz Minimum)
- Signal Generator for AM
- IF Gene-scope
- Loop Antenna for AM
- Signal Generator for FM
- Multiplex Generator
- Dummy Antenna for FM

CONTROL SETTINGS:

- Volume Control Maximum (AM-IF and RF, FM-RF); Minimum (FM-IF)
- Treble Control Center
- Bass Control Center
- Balance Control Center
- Tape Monitor Source
- Loudness Off

AM TUNER ALIGNMENT

AM ALIGNMENT – FUNCTION switch to AM position

Maintain generator output as low as possible for suitable indication.

ITEM	GENERATOR	AM DIAL SETTING	INDICATOR	PROCEDURE
1. IF ALIGNMENT	Connect 450 kHz sweep generator to TP1 and ground lead to chassis. Use 0.1 μ F capacitor in series with generator lead.	Position of non-interference Minimum Frequency	Scope vertical input to Pin 7 and ground lead to chassis. Set vertical sensitivity to 0.2 V/cm.	Adjust T03, T04 for maximum gain and best symmetry. Keep signal low enough for noise on response as shown in Figure 1.
2. FRONT END ALIGNMENT (603 kHz)	AM generator to EXT AM ANT and GND terminals Set to 603 kHz. Modulate with 400 Hz (30 % modulation).	Set to 600 kHz.	Connect oscilloscope to Record Out terminal.	Adjust Bar Antenna to maximum output. See Figure 2.
3. FRONT END ALIGNMENT (1404 kHz)	Set to 1404 kHz.	Set to 1400 kHz	Same as above	Adjust TC02 to maximum output.
4. TRACKING ALIGNMENT (522 kHz)		Set to 522 kHz	Connect DC VTVM to Pin 9.	Adjust T05 until VTVM reads 1.2 V.
5. TRACKING ALIGNMENT (1602 kHz)		Set to 1602 kHz	Same as above	Adjust TC01 until VTVM reads 8.0 V.
6. AM STOP ADJUSTMENT	Same as above Set generator at 999 kHz to antenna input (64 dB).	Set to 999 kHz		Check that Auto Stop Function works at 999 kHz on DIGITAL Counter.
7. SIGNAL IND. ADJUSTMENT	Set generator at 1000 kHz to antenna input (100 dB).	Same as above		Adjust VR05 until all LEDs light up.

RECOMMENDED TEST EQUIPMENTS

The following test equipments are recommended to completely test and align the Amplifier:

- Line Voltage Isolation Transformer
- AC DC Multimeter.
- Accurately Calibrated AC Voltmeter.
- Oscilloscope (Flat to 100 kHz Minimum)
- Low-Distortion Audio Sine-Wave Generator
- Harmonic Distortion Analyzer
- Two (2) Load Resistors 8-ohms, 250 Watts (Minimum Rating)

HARMONIC DISTORTION TEST

CAUTION: Limit the following tests to no more than ten minutes each. Use 8-ohm resistors, with a minimum power rating of 250 watts when connecting a load across the SPEAKERS terminal.

CONTROL SETTINGS:

Unplug the AC power cord and set the front panel controls as follows:

- BASS, TREBLE, and BALANCE controls to center positions.
- POWER switch to OFF
- SPEAKERS switch to OFF
- FUNCTION switch to AUX
- MODE switch to STEREO
- TAPE MONITOR switch to SOURCE
- LOUDNESS switch to OFF
- VOLUME control to MINIMUM position
- LEFT CHANNEL DRIVEN

ONE CHANNEL DRIVEN:

- 1) Connect a low distortion audio generator to LEFT AUX IN jack. Set generator frequency to 1 kHz and output to minimum.
- 2) Connect an 8-ohm load resistor between SPEAKERS A LEFT and COM terminals. Connect a Harmonic Distortion Analyzer and an AC VTVM in parallel across the 8-ohm load.
- 3) Connect the AC power cord and set SPEAKERS switch to A. Turn VOLUME control to MAX.
- 4) Increase generator output for 50 Watts RMS (20 V across the 8-ohm load). Harmonic Distortion Analyzer should measure 0.02 % distortion or less.
- 5) Repeat steps 1 through 4 for RIGHT CHANNEL.

BOTH CHANNELS DRIVEN

Connect 8-ohm load resistors across LEFT and RIGHT MAIN SPEAKERS terminals. Set MODE switch to "MONO". Adjust generator output and "BALANCE" control for 50 Watts at Left and Right Channels (20 volts across the 8-ohm loads). Harmonic Distortion Analyzer should measure 0.02 % distortion or less at each channel.

CAUTION: This precision high-fidelity instrument should be serviced only by qualified personnel, trained in the repair of transistor equipment and printed circuitry.

POWER AMP P.C.BOARD (TOP VIEW)

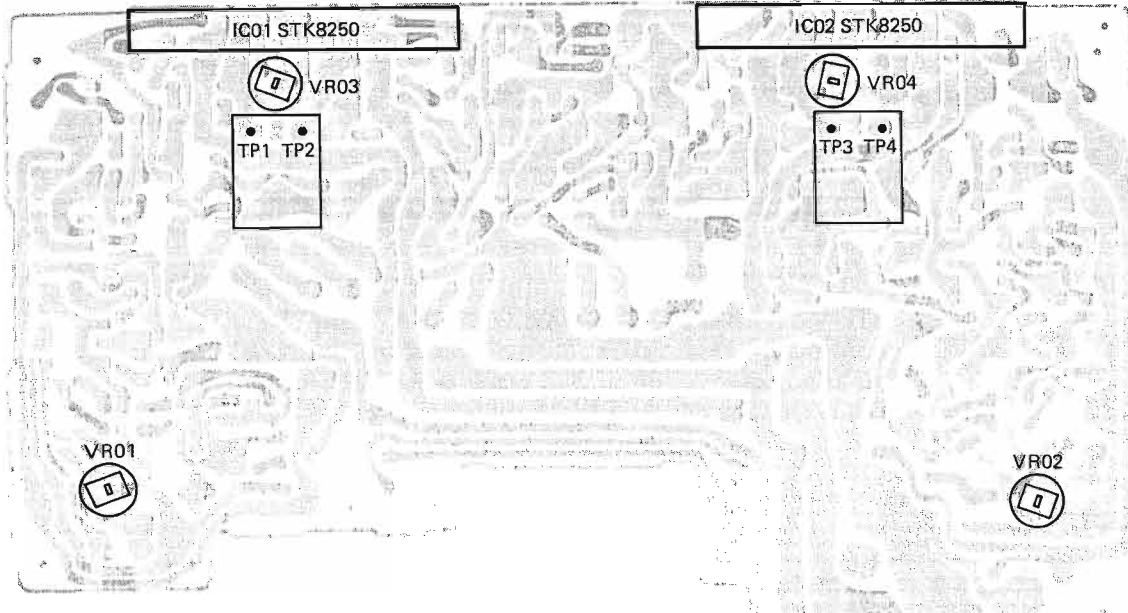

POWER LEVEL METER ADJUSTMENT

BEFORE ADJUSTMENT

1. Connect Audio Frequency Generator to the AUX input terminal.
2. Set Function Switch to "AUX" position.
3. Connect dummy load resistors (8 ohms) to the speaker terminal.
4. Use a DC V.T.V.M. (input impedance: more than 50 kohms/V).

POWER LEVEL METER ADJUSTMENT

1. Adjust Volume of the unit or Attenuator of the oscillator until AC V.T.V.M. reads 11.0 V. At this time, adjust VR01 and VR02 until the eighth LED lights up (The output becomes 50 W).
2. Reduce the input and set the indication of AC V.T.V.M. to 300 mV. Then, adjust VR03 and VR04 until the first LED lights up. (Confirm Items 1 and 2 again).

L.E.D. DRIVE P.C.BOARD (TOP VIEW)

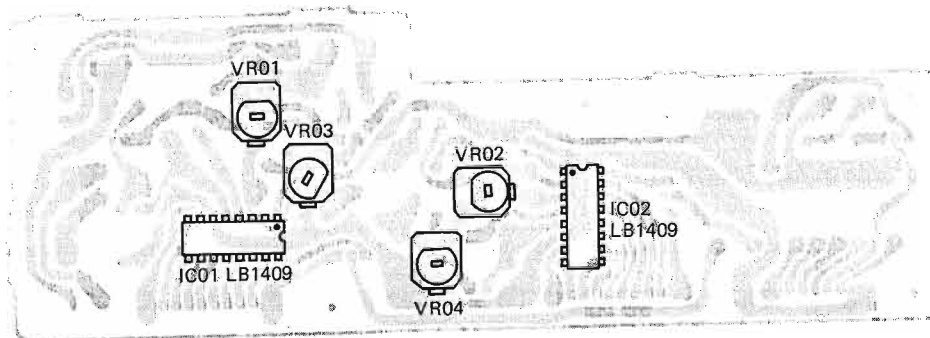

CHANNEL SPACE CHANGE-OVER IN SYNTHESIZER TUNER

Frequency spaces in FM/AM Synthesizer Tuner are made at every 50 kHz (FM) and 9 kHz (AM) point. The above frequency spaces can be changed over to 100 kHz (FM) and 10 kHz (AM) points when used in U.S.A. Change the spaces by the following procedures.

1. Turn off the power switch.
2. Remove R157 (100 k-ohm). (Fig. 1).
3. Connect Pin No. 6 of IC01 (TC9137P) to GND with a jumper lead. (Fig. 2).

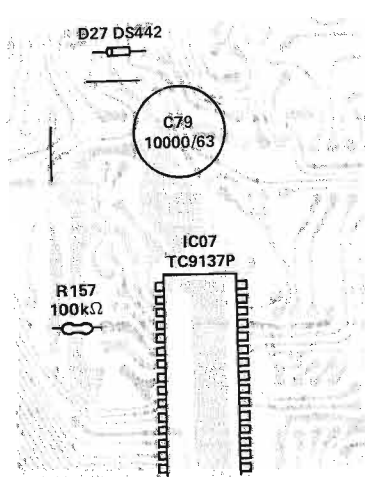

Figure 1

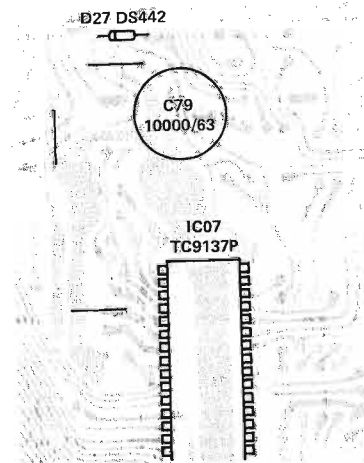

Figure 2

POWER AMPLIFIER ADJUSTMENT

BEFORE ADJUSTMENT

1. After setting the power switch to the ON position, allow a few minutes before making adjustment, to be sure of the most stable operation.
2. Connect dummy load resistors (8 ohms) to the Speaker terminals.
3. Use a DC V.T.V.M. (input impedance: More than 50 kohms/V).

ZERO BALANCE ADJUSTMENT

- Connect DC V.T.V.M. to the speaker output terminal and turn the volume control fully to the minimum position. Turn VR01 and VR02 in P.C.B. under the above condition until the output voltage becomes 0 ± 50 mV.

IDLING CURRENT ADJUSTMENT

1. Left channel
 - Connect DC V.T.V.M. between TP1 and TP2.
 - Adjust VR03 to 40mV DC voltmeter indication.
2. Right channel
 - Connect DC V.T.V.M. between TP3 and TP4.
 - Adjust VR04 to 40mV DC voltmeter indication.

PRE SCALAR IC TD6104P SIGNAL FLOW

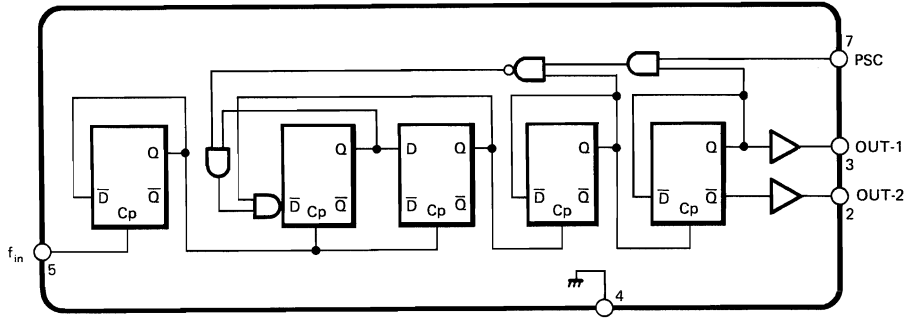

L.E.D. LEVEL METER IC LB1416 SIGNAL FLOW

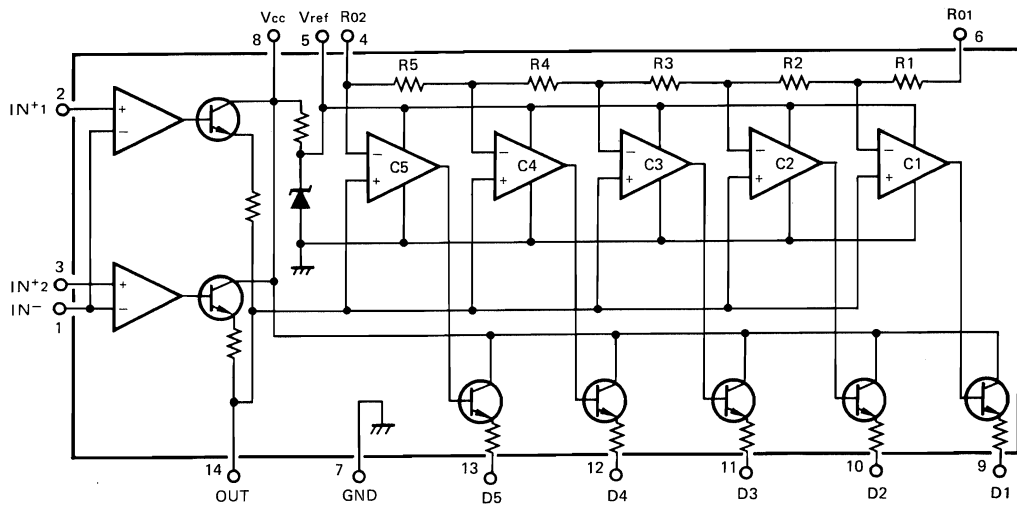

L.E.D. LEVEL METER IC LB1409 SIGNAL FLOW

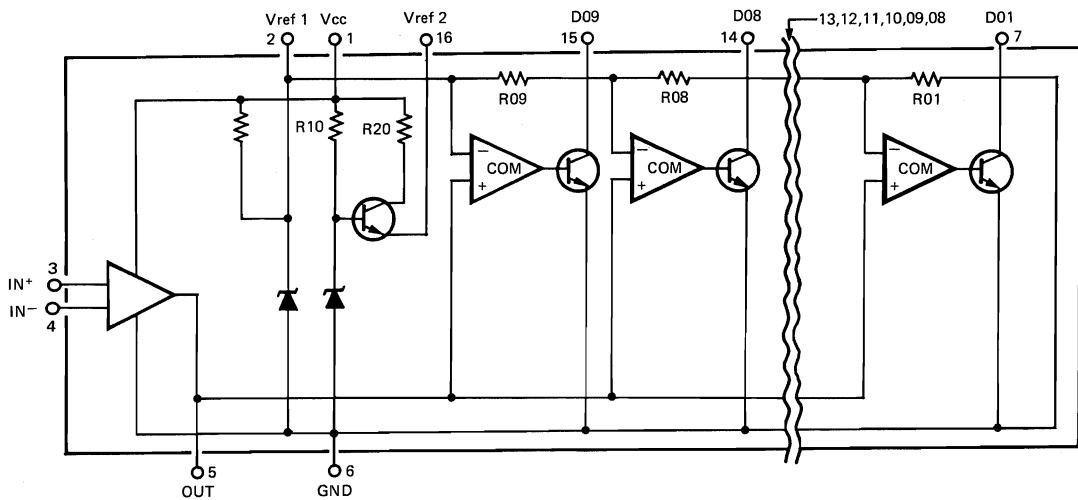

PLL CONTROL IC TC9137P SIGNAL FLOW

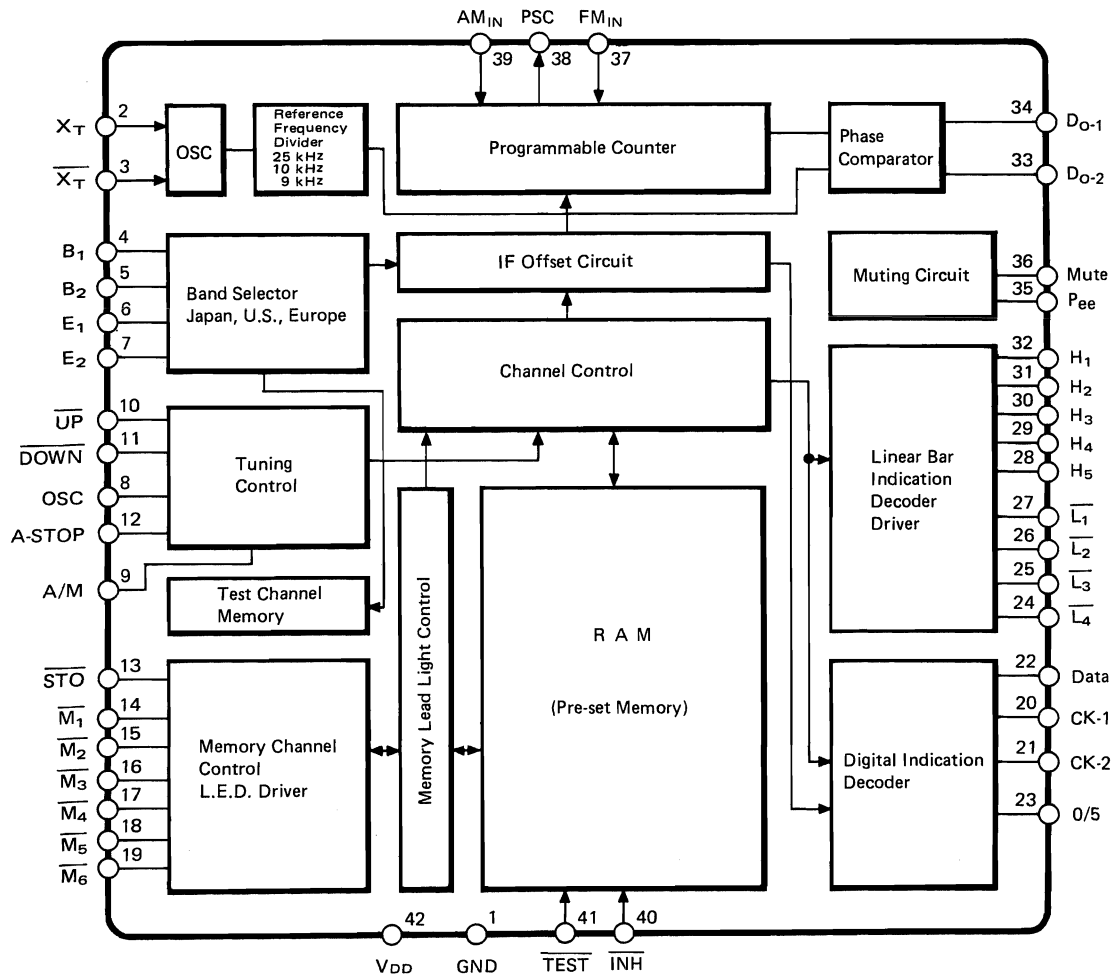

STATIC DRIVER IC TD6301P SIGNAL FLOW

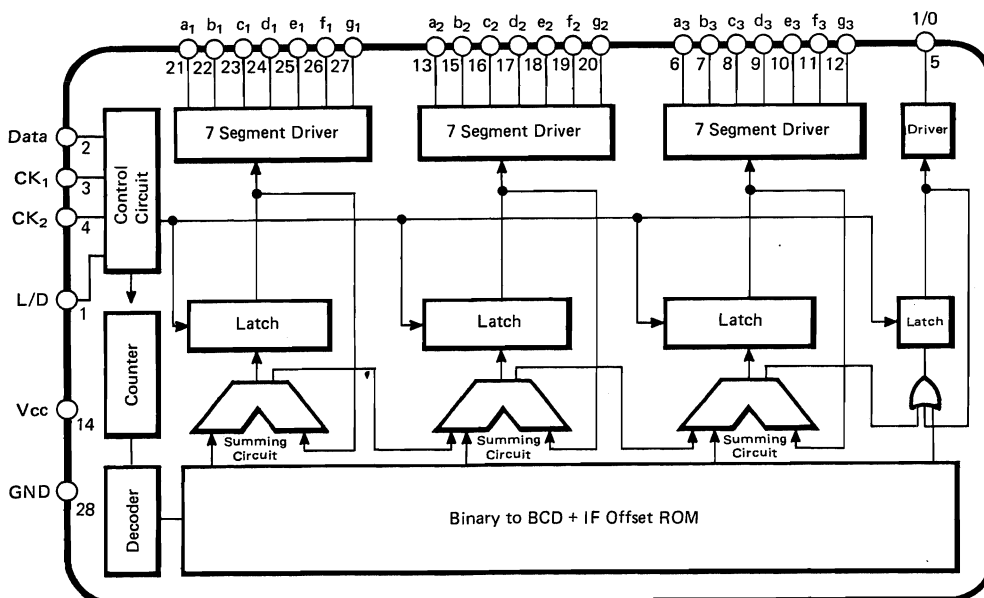

FM IF IC HA11225 SIGNAL FLOW

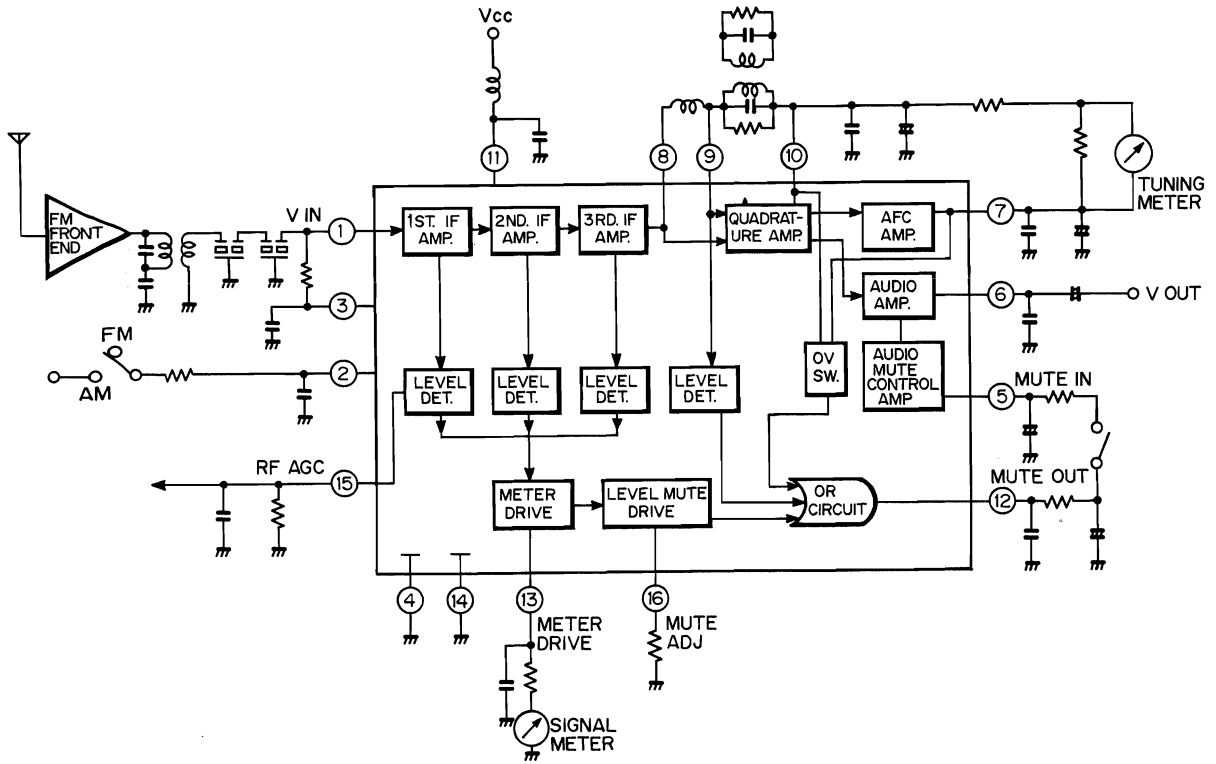

FM MPX IC HA12016 SIGNAL FLOW

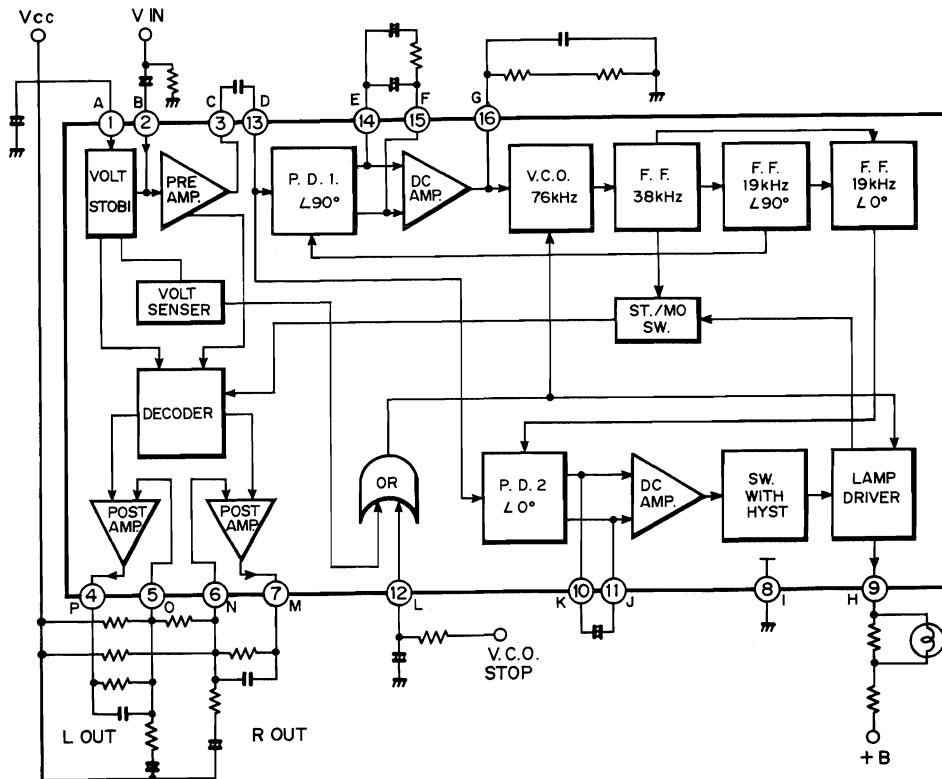

RF CONTROL P.C.BOARD LAYOUT

WITH OSCILLOSCOPE TIME BASE SETTINGS
(TOP VIEW)

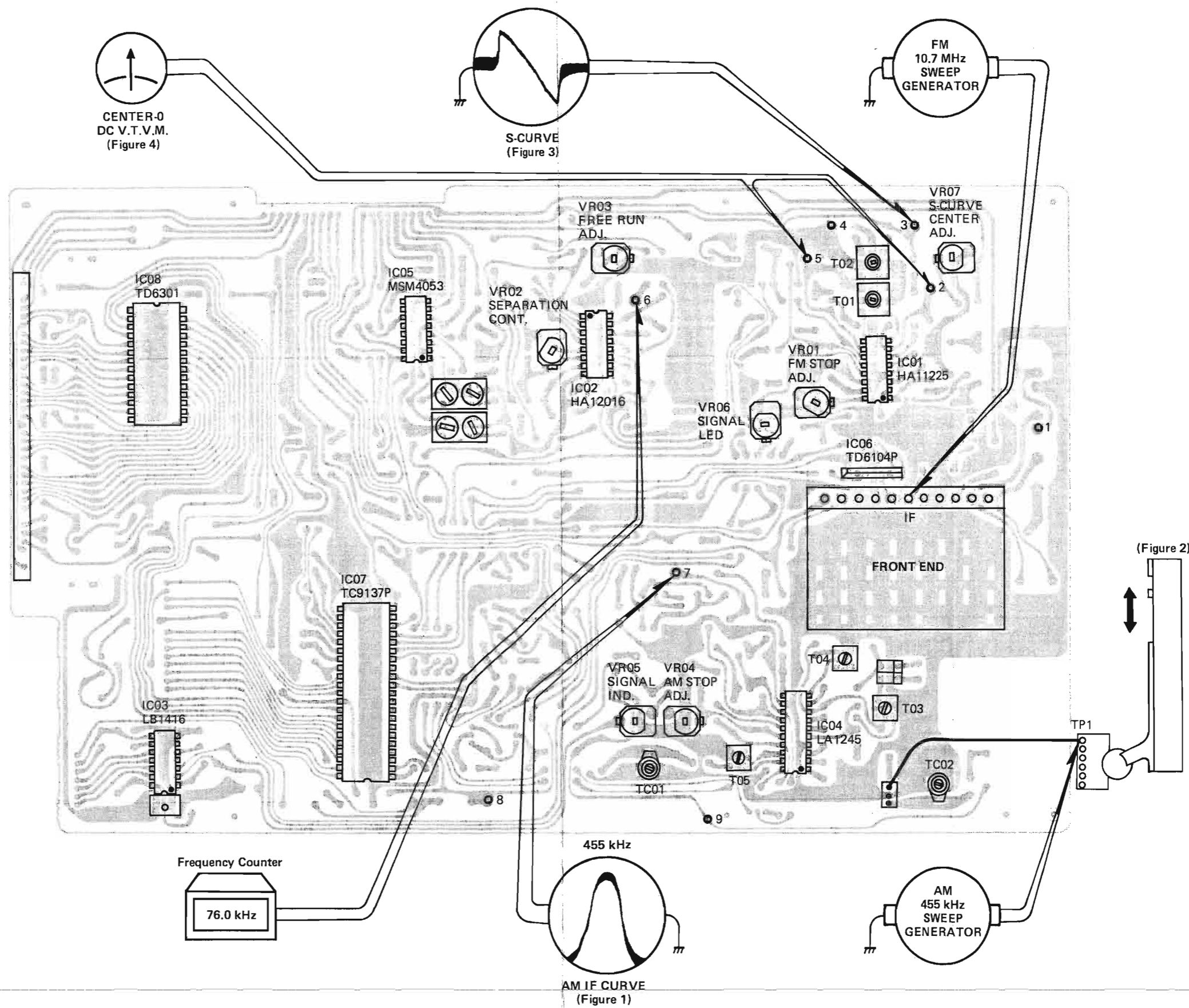

RF CONTROL P.C.BOARD (BOTTOM VIEW)

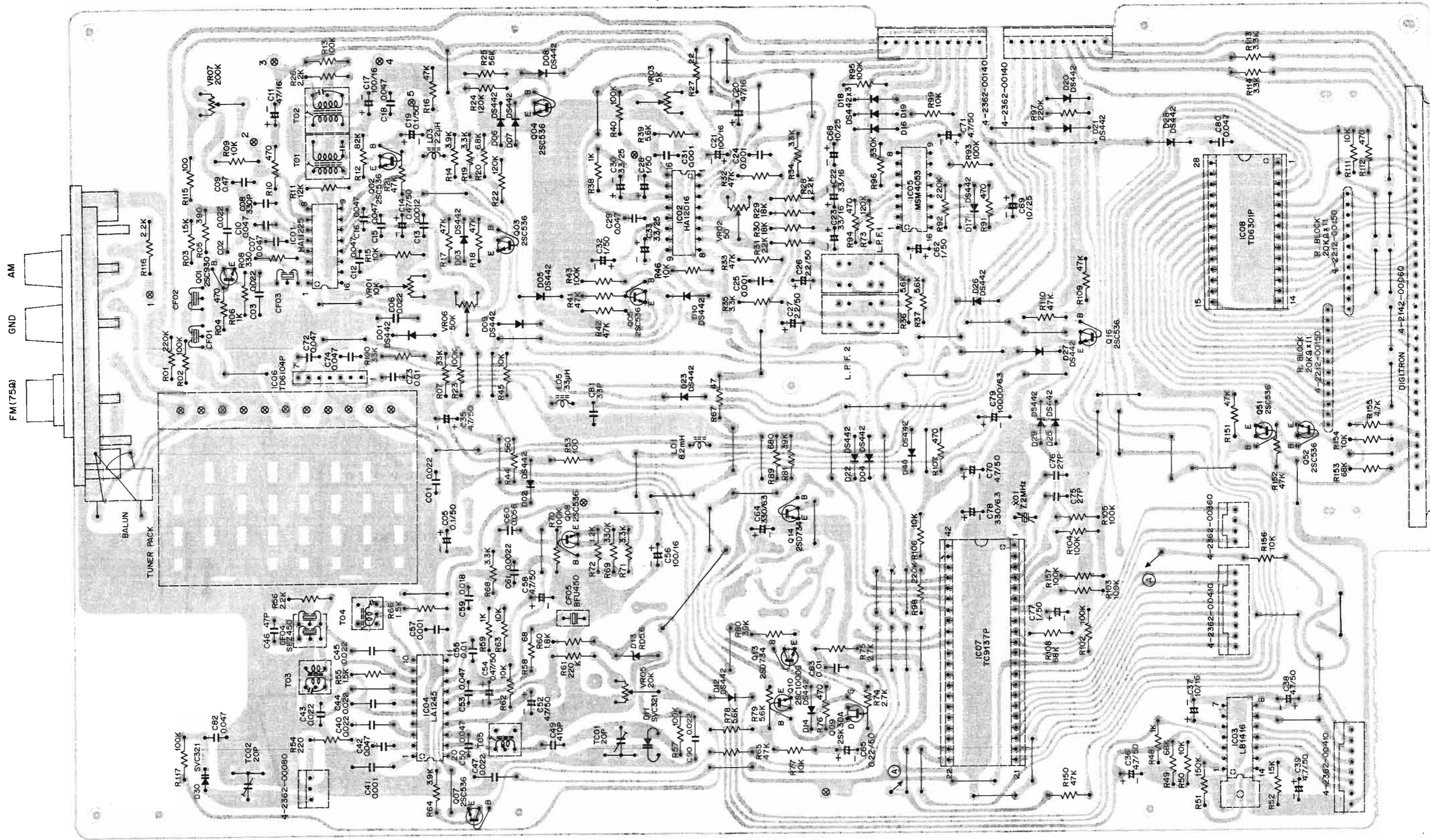

RF CONTROL P.C.B. IC PIN NUMBERS VOLTAGES																					
SYMBOL No.	DEVICE	1	2	3	4	5	6	7	8	9	10	11	12	13	14	15	16	17	18	19	20
IC01	HA11225	2.0V	2.0V	2.0V	0V	0V	5.4V	5.6V	5.7V	5.7V	5.7V	13.6V	3.4V	0V	0V	4.8V	3.6V	-	-	-	-
IC02	HA12016	13.2V	3.8V	5.5V	6.6V	11.4V	11.4V	6.7V	0V	4.8V	2.5V	2.5V	11.3V	2.5V	2.5V	2.5V	0V	-	-	-	-
IC04	LA1245	5.7V	2.2V	2.8V	0V	11.0V	2.1V	11.8V	11.8V	2.9V	8.7V	0.7V	0V	2.2V	12.8V	1.7V	0V	2.2V	5.7V	5.7V	3.0V

TONE AMP P.C.BOARD

(BOTTOM VIEW)

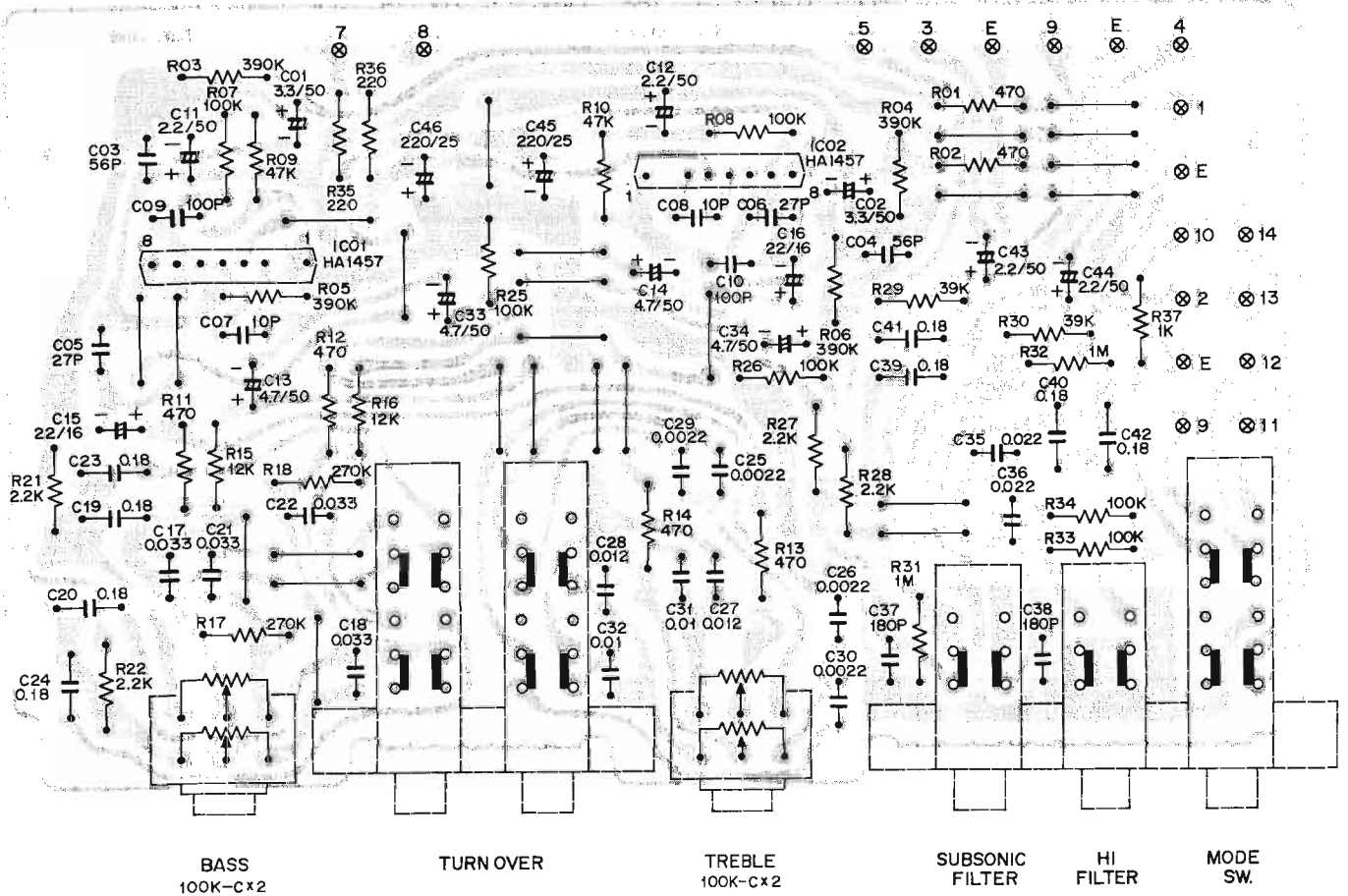

TONE AMP P.C.B. IC PIN NUMBERS VOLTAGES									
SYMBOL No.	DEVICE	1	2	3	4	5	6	7	8
IC01,02	HA1457	-0.2V	-	-0.3V	-22V	-21V	-0.2V	-0.3V	23.2V

RF CONTROL P.C.B. TRANSISTOR DC VOLTAGES														
SYMBOL No.	DEVICE	B	C	E	SYMBOL No.	DEVICE	B	C	E	SYMBOL No.	DEVICE	B	C	E
Q01	2SC930	3.1V	11.8V	2.4V	Q07	2SC536	0V	2.2V	2.2V	Q10	2SC1000	0.7V	14.3V	0V
Q02	2SC536	1.5V	5.6V	5.7V	Q08	2SC536	1.8V	9.5V	1.2V	Q12	2SC1000	0.6V	26.4V	0V
Q03	2SC536	0.7V	0V	0V			G	D	S	Q13	2SD734	0.7V	0V	0V
Q04	2SC536	0V	4.0V	0V	Q09	2SK30A	0.9V	3.5V	0.7V	Q14	2SD734	0.6V	0V	0V
Q05	2SC536	0V	11.3V	0V	Q11	2SK30A	0.2V	3.5V	0.6V					

SP TERMINAL 1 P.C.BOARD

(BOTTOM VIEW)

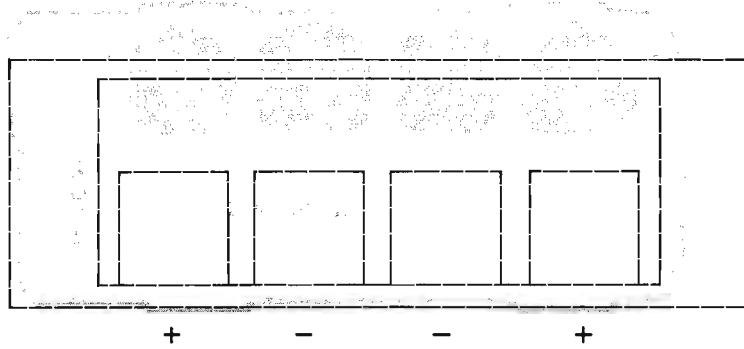

SP TERMINAL 2 P.C.BOARD

(BOTTOM VIEW)

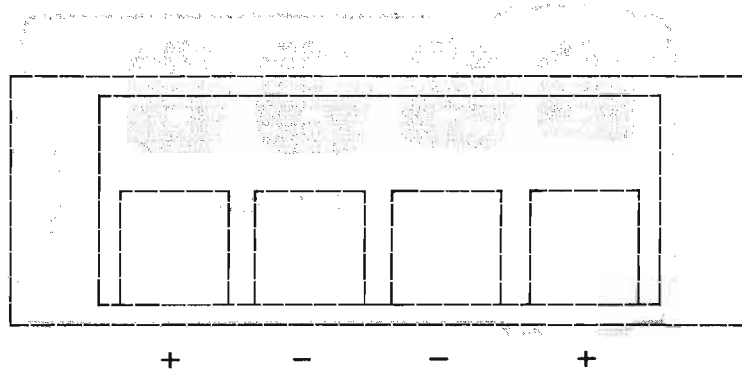

SIGNAL P.C.BOARD

(BOTTOM VIEW)

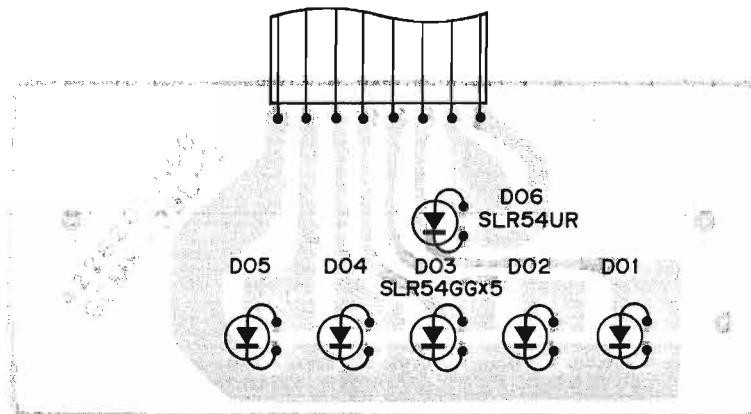

L.E.D. LAMP P.C.BOARD (BOTTOM VIEW)

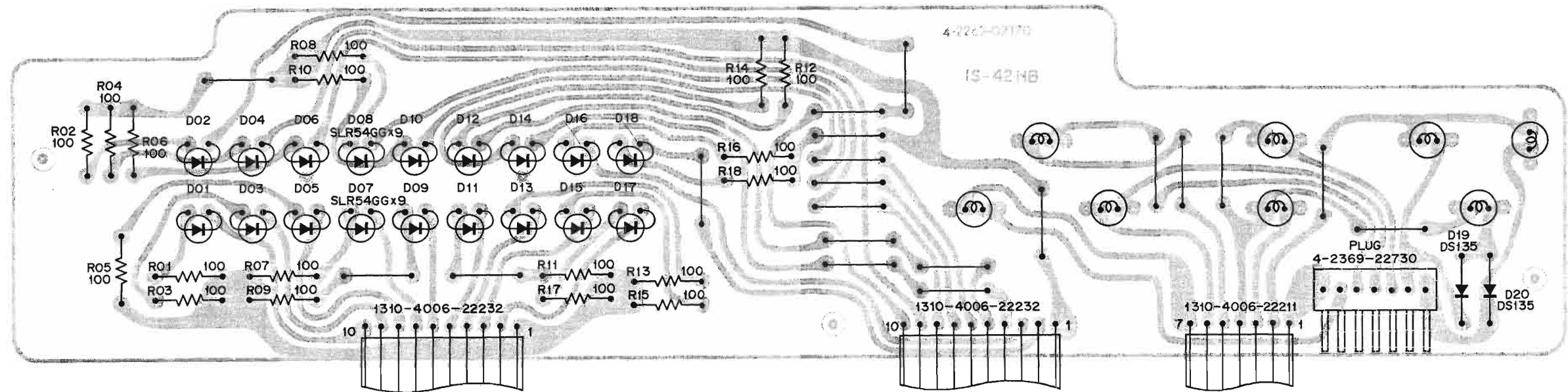

L.E.D. DRIVE P.C.BOARD (BOTTOM VIEW)

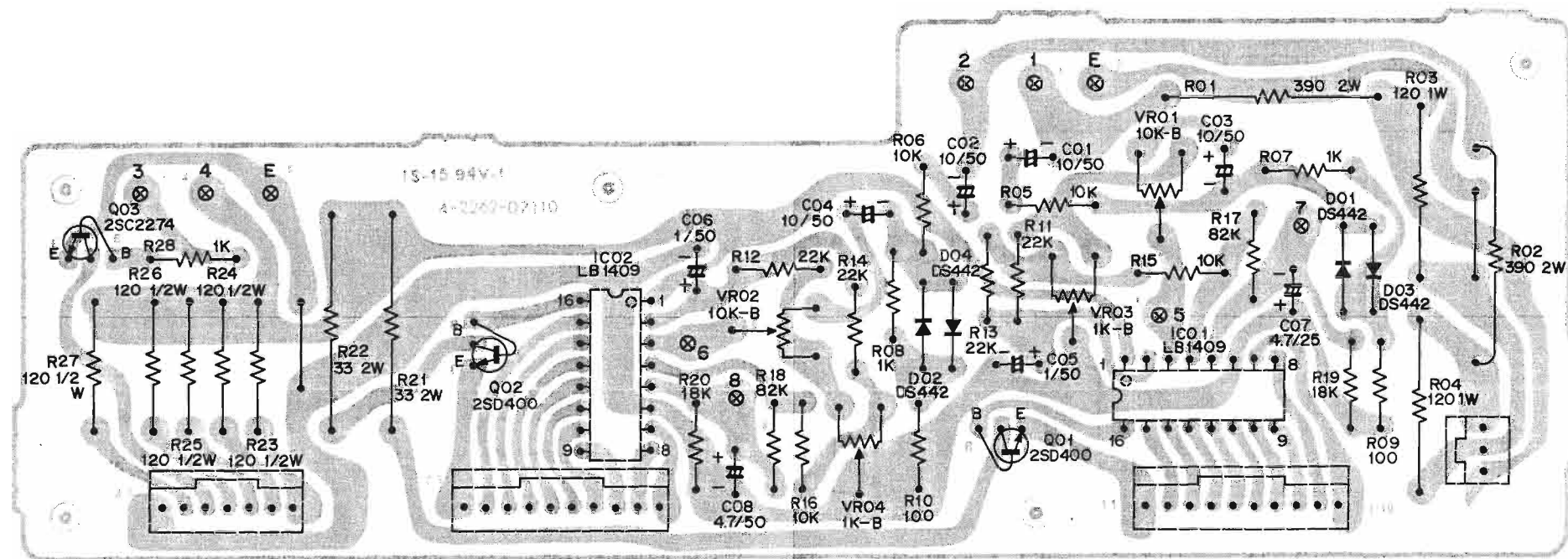

PHONO EQ P.C.BOARD (BOTTOM VIEW)

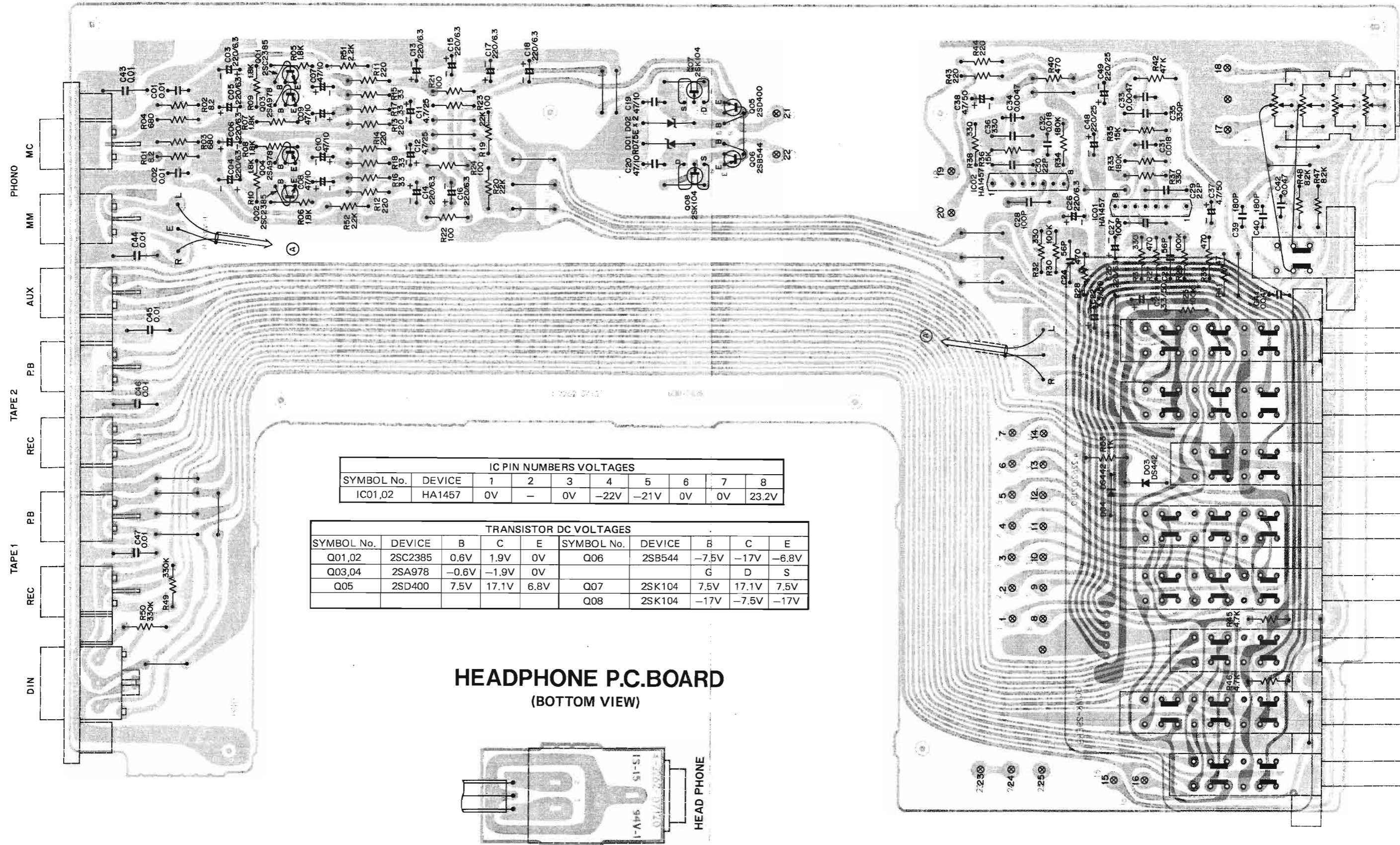

IC PIN NUMBERS VOLTAGES									
SYMBOL No.	DEVICE	1	2	3	4	5	6	7	8
IC01,02	HA1457	0V	-	0V	-22V	-21V	0V	0V	23.2V

TRANSISTOR DC VOLTAGES									
SYMBOL No.	DEVICE	B	C	E	SYMBOL No.	DEVICE	B	C	E
Q01,02	2SC2385	0.6V	1.9V	0V	Q06	2SB544	-7.5V	-17V	-6.8V
Q03,04	2SA978	-0.6V	-1.9V	0V			G	D	S
Q05	2SD400	7.5V	17.1V	6.8V	Q07	2SK104	7.5V	17.1V	7.5V
					Q08	2SK104	-17V	-7.5V	-17V

HEADPHONE P.C.BOARD (BOTTOM VIEW)

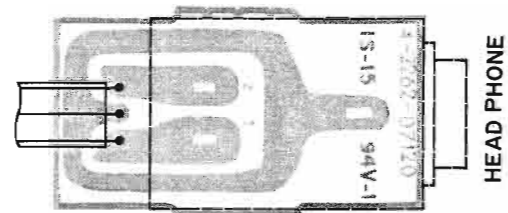

POWER AMP P.C.BOARD (BOTTOM VIEW)

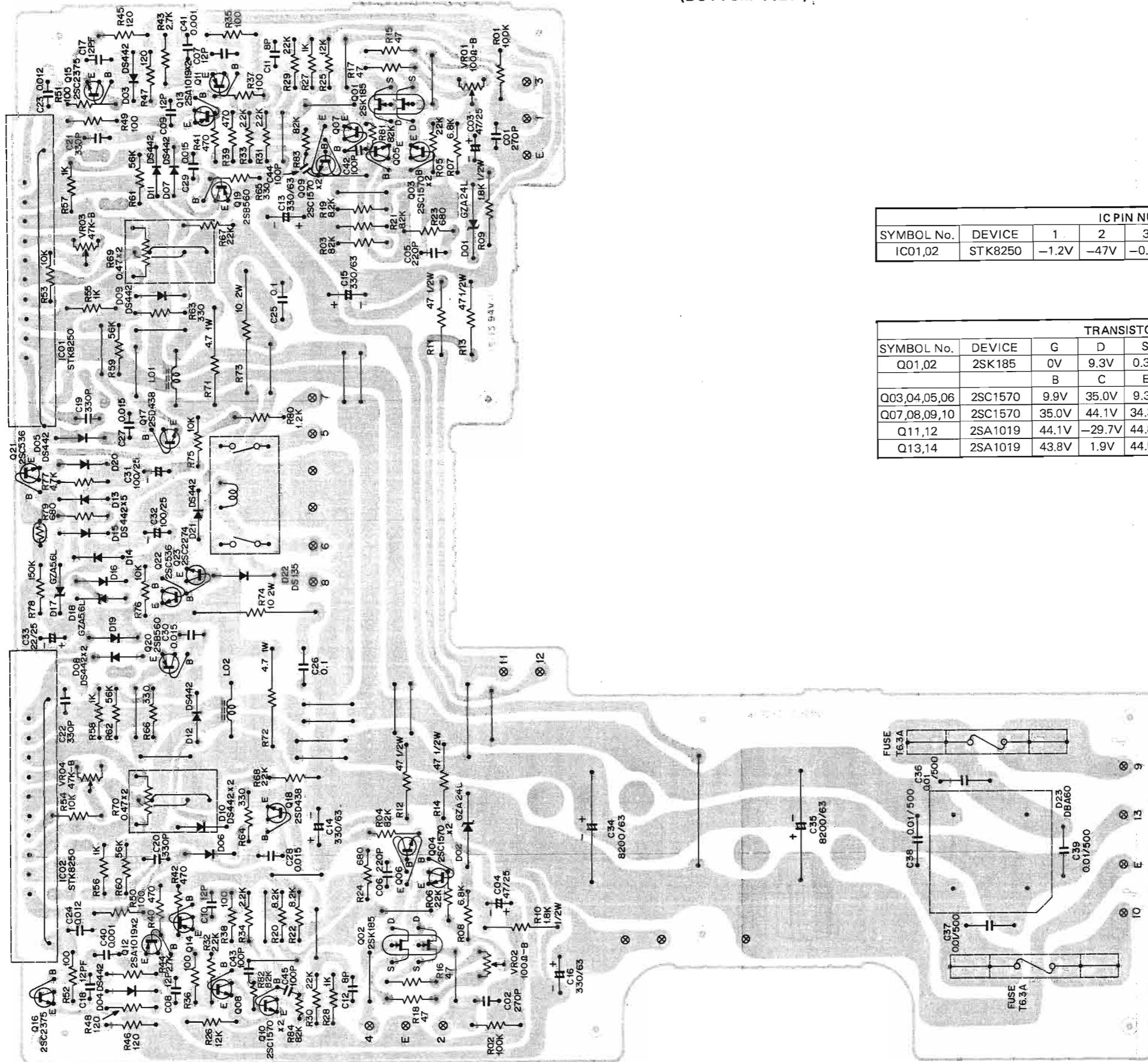

IC PIN NUMBERS VOLTAGES											
SYMBOL No.	DEVICE	1	2	3	4	5	6	7	8	9	10
IC01,02	STK8250	-1.2V	-47V	-0.6V	-0.7V	0V	0V	0.7V	0.7V	48V	1.2V

TRANSISTOR DC VOLTAGES									
SYMBOL No.	DEVICE	G	D	S	SYMBOL No.	DEVICE	B	C	E
Q01,02	2SK185	0V	9.3V	0.3V	Q15,16	2SC2375	-45V	-1.8V	-45V
		B	C	E	Q17,18	2SD438	0.2V	1.0V	0V
Q03,04,05,06	2SC1570	9.9V	35.0V	9.3V	Q19,20	2SB560	-0.2V	-1.0V	0V
Q07,08,09,10	2SC1570	35.0V	44.1V	34.3V	Q21	2SC536	0V	5.5V	0V
Q11,12	2SA1019	44.1V	-29.7V	44.8V	Q22	2SC536	2.0V	1.5V	1.4V
Q13,14	2SA1019	43.8V	1.9V	44.5V	Q23	2SC2274	1.4V	1.5V	0.8V

**POWER SUPPLY P.C.BOARD
(BOTTOM VIEW)**

TRANSISTOR DC VOLTAGES				
SYMBOL No.	DEVICE	B	C	E
Q01	2SD438	43V	43.2V	42.4V
Q02	2SD438	21.6V	36.8V	21.1V
Q03	2SD438	25.4V	37.7V	24.8V
Q04	2SB560	-24.3V	-36.9V	-23.7V
Q05	2SC536	13.3V	13.4V	12.6V
Q06	2SD794	6.5V	12.6V	5.9V

**POWER IND. P.C.BOARD
(BOTTOM VIEW)**

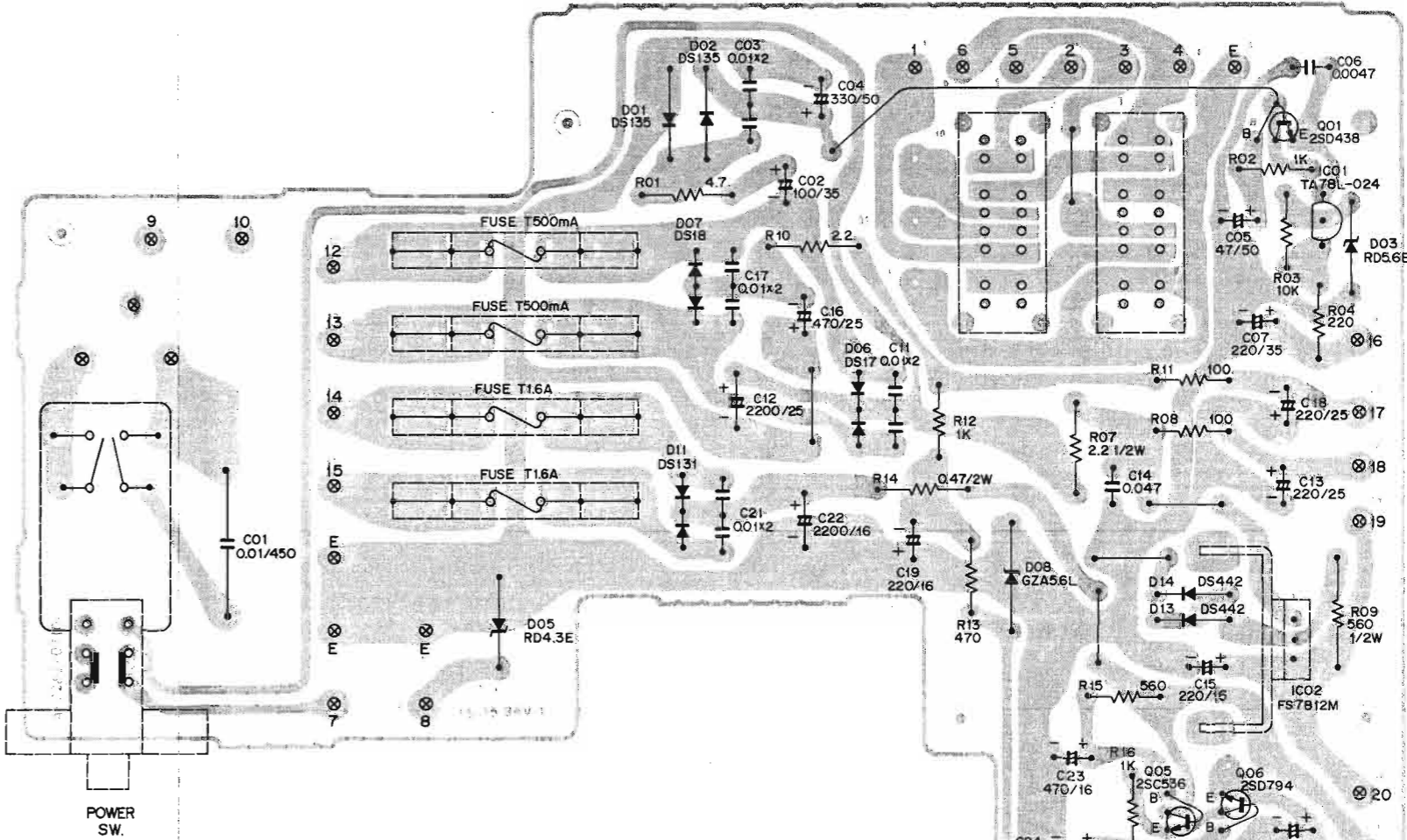
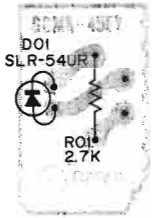

**SWITCH P.C.BOARD
(BOTTOM VIEW)**

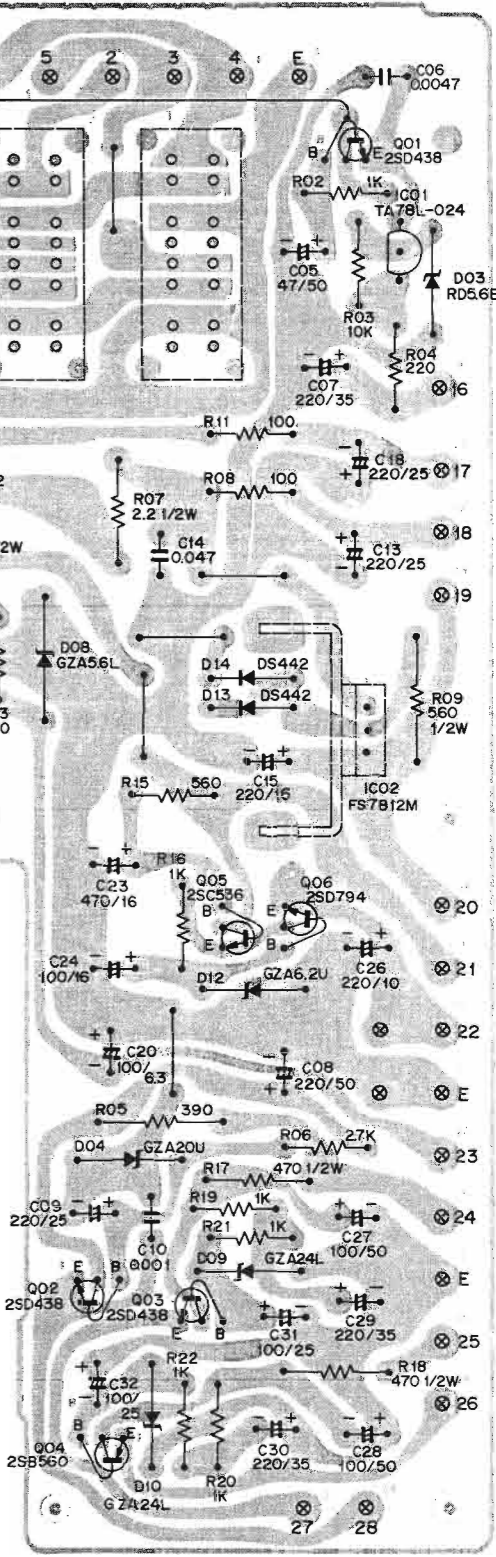
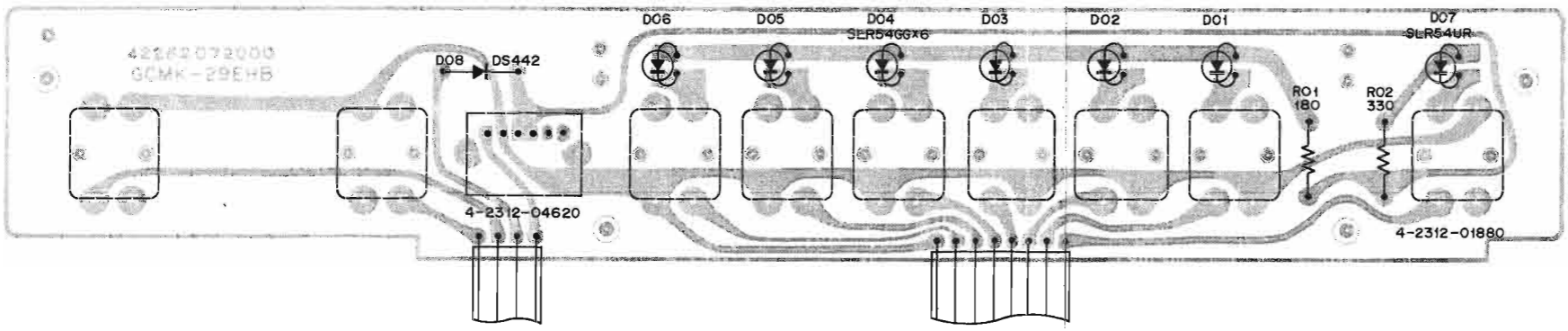

PARTS LIST (Continued)

Ref. No.	Parts Number	Description	Ref. No.	Parts Number	Description
SEMICONDUCTORS			RESISTORS		
IC06	ITT-TD-6104P	IC, TD6104P	R53	R2EDPJ101A	Carbon 100 1/4W ±5%
IC07	ITT-TC9137P	IC, TC9137P	R54	R2EDZJ221APA	Carbon 220 1/4W ±5%
IC08	ITT-TD6301P	IC, TD6301P	R55	R2EDZJ152APA	Carbon 1.5k 1/4W ±5%
Q01	203 5 5500 93050	TR 2SC930 E, F	R56	R2EDZJ222APA	Carbon 2.2k 1/4W ±5%
Q02,03	203 5 5000 53650	TR 2SC536 E, F	R57	R2EDZJ104APA	Carbon 100k 1/4W ±5%
04,05			R58	R2EDZJ680APA	Carbon 68 1/4W ±5%
07,08			R59	R2EDZJ102APA	Carbon 1k 1/4W ±5%
Q09	TTT-2SK30A-O	TR 2SK30A O	R60	R2EDZJ182APA	Carbon 1.8k 1/4W ±5%
Q10	TTT-2SC1000GBL	TR 2SC1000G BL	R61	R2EDZJ224APA	Carbon 220k 1/4W ±5%
Q13	203 5 4570 73452	TR 2SD734 E, F	R62,63	R2EDZJ103APA	Carbon 10k 1/4W ±5%
Q16,51	203 5 5000 53650	TR 2SC536 E, F	R64	R2EDZJ392APA	Carbon 3.9k 1/4W ±5%
52			R65	R2EDZJ473APA	Carbon 47k 1/4W ±5%
RESISTORS			R66	R2EDZJ152APA	Carbon 1.5k 1/4W ±5%
R01	R2EDZJ224APA	Carbon 220k 1/4W ±5%	R67	R2EDPJ470A	Carbon 47 1/4W ±5%
R02	R2EDZJ104APA	Carbon 100k 1/4W ±5%	R68	R2EDZJ332APA	Carbon 3.3k 1/4W ±5%
R03	R2EDZJ152APA	Carbon 1.5k 1/4W ±5%	R69	R2EDZJ334APA	Carbon 330k 1/4W ±5%
R04	R2EDZJ471 APA	Carbon 470 1/4W ±5%	R70	R2EDZJ104APA	Carbon 100k 1/4W ±5%
R05	R2EDZJ391 APA	Carbon 390 1/4W ±5%	R71	R2EDZJ332APA	Carbon 3.3k 1/4W ±5%
R06	R2EDZJ102APA	Carbon 1k 1/4W ±5%	R72	R2EDZJ122APA	Carbon 1.2k 1/4W ±5%
R07	R2EDZJ333APA	Carbon 33k 1/4W ±5%	R73	R2EDZJ124APA	Carbon 120k 1/4W ±5%
R08	R2EDZJ331 APA	Carbon 330 1/4W ±5%	R74,75	R2EDZJ272APA	Carbon 2.7k 1/4W ±5%
R09	R2EDZJ103APA	Carbon 10k 1/4W ±5%	R76	R2EDZJ471 APA	Carbon 470 1/4W ±5%
R10	R2EDZJ471 APA	Carbon 470 1/4W ±5%	R77	R2EDZJ103APA	Carbon 10k 1/4W ±5%
R11	R2EDZJ123APA	Carbon 12k 1/4W ±5%	R78,79	R2EDZJ562APA	Carbon 5.6k 1/4W ±5%
R12	R2EDZJ823APA	Carbon 82k 1/4W ±5%	R80,81	R2EDZJ393APA	Carbon 39k 1/4W ±5%
R13	R2EDZJ104APA	Carbon 100k 1/4W ±5%	R89	R2EDZJ681 APA	Carbon 680 1/4W ±5%
R14	R2EDZJ392APA	Carbon 3.9k 1/4W ±5%	R91	R2EDZJ471 APA	Carbon 470 1/4W ±5%
R15	R2EDZJ103APA	Carbon 10k 1/4W ±5%	R92	R2EDZJ224APA	Carbon 220k 1/4W ±5%
R16,17	R2EDZJ473APA	Carbon 47k 1/4W ±5%	R93	R2EDZJ104APA	Carbon 100k 1/4W ±5%
18			R94	R2EDZJ471 APA	Carbon 470 1/4W ±5%
R19	R2EDZJ332APA	Carbon 3.3k 1/4W ±5%	R95	R2EDZJ104APA	Carbon 100k 1/4W ±5%
R20	R2EDZJ682APA	Carbon 6.8k 1/4W ±5%	R96	R2EDZJ334APA	Carbon 330k 1/4W ±5%
R21	R2EDZJ473APA	Carbon 47k 1/4W ±5%	R97,98	R2EDZJ224APA	Carbon 220k 1/4W ±5%
R22	R2EDZJ124APA	Carbon 120k 1/4W ±5%	R99	R2EDZJ103APA	Carbon 10k 1/4W ±5%
R23	R2EDZJ104APA	Carbon 100k 1/4W ±5%	R100	R2EDZJ333APA	Carbon 33k 1/4W ±5%
R24	R2EDZJ124APA	Carbon 120k 1/4W ±5%	R102,103	R2EDZJ104APA	Carbon 100k 1/4W ±5%
R25	R2EDZJ563APA	Carbon 56k 1/4W ±5%	104,105		
R26	R2EDZJ222APA	Carbon 2.2k 1/4W ±5%	R106	R2EDZJ103APA	Carbon 10k 1/4W ±5%
R27	R2EDPJ220A	Carbon 22 1/4W ±5%	R107	R2EDZJ471 APA	Carbon 470 1/4W ±5%
R28	R2EDZJ222APA	Carbon 2.2k 1/4W ±5%	R108	R2EDZJ683APA	Carbon 68k 1/4W ±5%
R29,30	R2EDZJ183APA	Carbon 18k 1/4W ±5%	R109,110	R2EDZJ473APA	Carbon 47k 1/4W ±5%
R31	R2EDZJ222APA	Carbon 2.2k 1/4W ±5%	R111	R2EDZJ103APA	Carbon 10k 1/4W ±5%
R32,33	R2EDZJ473APA	Carbon 47k 1/4W ±5%	R112	R2EDZJ471 APA	Carbon 470 1/4W ±5%
R34,35	R2EDZJ332APA	Carbon 3.3k 1/4W ±5%	R113,114	R2EDZJ332APA	Carbon 3.3k 1/4W ±5%
R36,37	R2EDZJ562APA	Carbon 5.6k 1/4W ±5%	R115	R2EDPJ101A	Carbon 100 1/4W ±5%
R38	R2EDZJ102APA	Carbon 1k 1/4W ±5%	R116	R2HXB222A	Oxide Metal Film 2.2k 1/2W ±5%
R39	R2EDZJ562APA	Carbon 5.6k 1/4W ±5%	R117	R2EDZJ104APA	Carbon 100k 1/4W ±5%
R40	R2EDZJ104APA	Carbon 100k 1/4W ±5%	R150	R2EDZJ154APA	Carbon 150k 1/4W ±5%
R41,42	R2EDZJ473APA	Carbon 47k 1/4W ±5%	R151	R2EDZJ473APA	Carbon 47k 1/4W ±5%
R43	R2EDZJ104APA	Carbon 100k 1/4W ±5%	R152	R2EDZJ104APA	Carbon 100k 1/4W ±5%
R44	R2EDZJ561 APA	Carbon 560 1/4W ±5%	R153	R2EDZJ682APA	Carbon 6.8k 1/4W ±5%
R45,46	R2EDZJ103APA	Carbon 10k 1/4W ±5%	R154	R2EDZJ103APA	Carbon 10k 1/4W ±5%
R48	R2EDZJ102APA	Carbon 1k 1/4W ±5%	R155	R2EDZJ472APA	Carbon 4.7k 1/4W ±5%
R49	R2EDZJ683APA	Carbon 68k 1/4W ±5%	R156	R2EDZJ103APA	Carbon 10k 1/4W ±5%
R50	R2EDZJ103APA	Carbon 10k 1/4W ±5%	R157	R2EDZJ104APA	Carbon 100k 1/4W ±5%
R51	R2EDZJ154APA	Carbon 150k 1/4W ±5%			
R52	R2EDZJ153APA	Carbon 15k 1/4W ±5%			

PARTS LIST (Continued)

SWITCH P.C.B. Assy
131 0 4001 05740

Ref. No.	Parts Number	Description
	4 2312 01880	Key Board Switch
	4 2312 04620	Switch Push 1Key
	131 2 6113 39400	Shelter
SEMICONDUCTORS		
D01,02	DYY-SLR-54GG	Diode, SLR-54GG (LED)
03,04		
05,06		
D07	DYY-SLR-54UR	Diode, SLR-54UR (LED)
D08	205 5 9040 44210	Diode, DS-442
RESISTORS		
R01	R2EDPJ181A	Carbon 180 1/4W ±5%
R02	R2EDPJ331A	Carbon 330 1/4W ±5%

SIGNAL P.C.B. Assy
131 0 4001 05750

Ref. No.	Parts Number	Description
SEMICONDUCTORS		
D01,02	DYY-SLR-54GG	Diode, SLR-54GG (LED)
03,04		
05		
D06	DYY-SLR-54UR	Diode, SLR-54UR (LED)

POWER AMP P.C.B. Assy
131 0 4001 05641

Ref. No.	Parts Number	Description
VR01,02	4 2222 00240	VR 100-B
VR03,04	4 2229 25100	VR 47k-B
	4 2322 00090	Relay
⚠	4 2349 21570	Fuse T 6.3 A
L01,02	4 2532 00180	RF Filter
	HLL-PTH487A-BF	Posistor
CAPACITORS		
C01,02	C1HCYK271APA	Ceramic 270 pF 50V ±10%
C03	C1ERE-476A	Electrolytic 47 μF 25V
C04	C1ERY-476APA	Electrolytic 47 μF 25V
C05,06	C1HCYK221APA	Ceramic 220 pF 50V ±10%
C07,08	C1HCDJ120SL	Ceramic 12 pF 50V ±5%
09,10		
C11,12	C1HCDD080SL	Ceramic 8 pF 50V ±0.5%
C13,14	C1JRE-337A	Electrolytic 330 μF 63V
15,16		
C17,18	C1HCDJ120SL	Ceramic 12 pF 50V ±5%
C19,20	C1HCDK331SL	Ceramic 330 pF 50V ±10%
C21	C1HCYK331APA	Ceramic 330 pF 50V ±10%
C22	C1HCDK331SL	Ceramic 330 pF 50V ±10%
C23,24	C1HFKYK123APA	Mylar 0.012 μF 50V ±10%
C25,26	C1HFRK104A	Mylar 0.1 μF 50V ±10%
C27,28	C1HFKYK153APA	Mylar 0.015 μF 50V ±10%
C29	C1HFRK153A	Mylar 0.015 μF 50V ±10%
C30	C1HFKYK153APA	Mylar 0.015 μF 50V ±10%
C31,32	C1EAEN107A	Electrolytic 100 μF 25V ±30%

Ref. No.	Parts Number	Description
CAPACITORS		
C33	C1ERE-226A	Electrolytic 22 μF 25V
C34,35	4 2232 00580	Electrolytic 8200 μF 63V
C36,37	C2HYDP103A	Ceramic 0.01 μF 500V +100,-0%
38,39		
C40,41	C1HFKYK102APA	Mylar 0.001 μF 50V ±10%
C42,43	C1HCDK101A	Ceramic 100 pF 50V ±10%
44,45		

Ref. No.	Parts Number	Description
SEMICONDUCTORS		
D01,02	202 5 3210 24010	Diode, GZA 24L
D03,04	205 5 9040 44210	Diode, DS-442

05,06		
07,08		
09,10		
11,12		
13,14		
15,16		
D17,18	202 5 3210 05610	Diode, GZA 5.6L
D19,20	205 5 9040 44210	Diode, DS-442
21		
D22	202 5 2470 13540	Diode, DS-135
D23	202 5 2750 06015	Diode, DBA-60C-K15
IC01,02	206 5 4368 25010	IC, STK8250
Q01,02	TVV-2SK185	TR 2SK185 (Dual)
Q03,04	203 5 5251 57070	TR 2SC1570 G, H
05,06		
07,08		
09,10		
Q11,12	203 5 6731 01960	TR 2SA1019 F, G
13,14		
Q15,16	203 5 6722 37560	TR 2SC2375 F, G
Q17,18	203 5 6830 43850	TR 2SD438 E, F
Q19,20	203 5 6840 56050	TR 2SB560 E, F
Q21,22	203 5 5000 53660	TR 2SC536 F, G
Q23	203 5 7252 27450	TR 2SC2274 E, F

Ref. No.	Parts Number	Description
RESISTORS		
R01,02	R2EDZJ104APA	Carbon 100k 1/4W ±5%
R03,04	R2EDZJ823APA	Carbon 82k 1/4W ±5%
R05,06	R2EDZJ223APA	Carbon 22k 1/4W ±5%
R07,08	R2EDZJ682APA	Carbon 6.8k 1/4W ±5%
R09,10	R2HZBJ182A	Oxide Metal Film 1.8k 1/2W ±5%
R11,12	R2HZPK470A	Fuse 47 1/2W ±10%
13,14		
R15,16	R2EDZJ470APA	Carbon 47 1/4W ±5%
17,18		
R19,20	R2EDZJ822APA	Carbon 8.2k 1/4W ±5%
21,22		
R23,24	R2EDZJ681APA	Carbon 680 1/4W ±5%
R25,26	R2EDZJ123APA	Carbon 12k 1/4W ±5%
R27,28	R2EDZJ102APA	Carbon 1k 1/4W ±5%
R29,30	R2EEZJ223APA	Carbon 22k 1/4W ±5%
R31,32	R2EDZJ222APA	Carbon 2.2k 1/4W ±5%
33,34		
R35,36	R2EDZJ101APA	Carbon 100 1/4W ±5%
37,38		
R39,40	R2EDZJ471APA	Carbon 470 1/4W ±5%
41,42		

PARTS LIST (Continued)

Ref. No.	Parts Number	Description
CAPACITORS		
R43,44	R2EDZJ272APA	Carbon 2.7k 1/4W ±5%
R45,46 47,48	R2EDZJ121APA	Carbon 120 1/4W ±5%
R49,50 51,52	R2EDZJ101APA	Carbon 100 1/4W ±5%
R53,54	R2EDZJ103APA	Carbon 10k 1/4W ±5%
R55,56 57,58	R2EDZJ102APA	Carbon 1k 1/4W ±5%
R59,60 61,62	R2EDZJ563APA	Carbon 56k 1/4W ±5%
R63,64 65,66	R2EDZJ331APA	Carbon 330 1/4W ±5%
R67,68	R2EDZJ223APA	Carbon 22k 1/4W ±5%
R69,70	4 2212 00050	Cement 0.47 5Wx2 ±10%
R71,72	R3AXB4R7A	Oxide Metal Film 4.7 1W ±5%
R73,74	R3DXBJ100A	Oxide Metal Film 10 2W ±5%
R75,76	R2EDZJ103APA	Carbon 10k 1/4W ±5%
R77	R2EDZJ472APA	Carbon 4.7k 1/4W ±5%
R78	R2EDZJ154APA	Carbon 150k 1/4W ±5%
R79	R2EDZJ681APA	Carbon 680 1/4W ±5%
R80	R2EDZJ122APA	Carbon 1.2k 1/4W ±5%
R81,82 83,84	R2EDUJ823A	Carbon 82k 1/4W ±5%

**POWER SUPPLY P.C.B. Assy
131 0 4001 05652**

Ref. No.	Parts Number	Description
△	4 2312 01400	Switch Push Power
	4 2312 04700	Switch Slide 4-2
△	4 2349 20240	Fuse T 1.6 A
△	4 2349 20310	Fuse T 500 mA
	131 2 6201 21500	Plate Heat Sink
CAPACITORS		
C01 △	4 2232 00550	Oil 0.01 μF 450V
C02	C1VRE-107A	Electrolytic 100 μF 35V
C03 △	4 2232 00430	Ceramic 0.01 μFx2 250V
C04	C1HRF-337A	Electrolytic 330 μF 50V
C05	C1HRY-476APA	Electrolytic 47 μF 50V
C06	C1HYDZ473A	Ceramic 0.047 μF 50V +80,-20%
C07	C1VRE-227A	Electrolytic 220 μF 35V
C08	C1HRE-227A	Electrolytic 220 μF 50V
C09	C1ERE-227A	Electrolytic 220 μF 25V
C10	C1HFYK102APA	Mylar 0.001 μF 50V ±10%
C11	4 2232 00430	Ceramic 0.01 μFx2 250V
C12	C1ERE-228A	Electrolytic 2200 μF 25V
C13	C1ERE-227A	Electrolytic 220 μF 25V
C14	C1HYDZ473A	Ceramic 0.047 μF 50V +80,-20%
C15	C1CRE-227A	Electrolytic 220 μF 16V
C16	C1ERE-477A	Electrolytic 470 μF 25V
C17	4 2232 00430	Ceramic 0.01 μFx2 250V
C18	C1ERE-227A	Electrolytic 220 μF 25V
C19	C1CRE-227A	Electrolytic 220 μF 16V
C20	C0JRY-107APA	Electrolytic 100 μF 6.3V
C21	4 2232 00430	Ceramic 0.01 μFx2 250V

Ref. No.	Parts Number	Description
CAPACITORS		
C22	C1CRE-228A	Electrolytic 2200 μF 16V
C23	C1CRE-477A	Electrolytic 470 μF 16V
C24	C1CRY-107APA	Electrolytic 100 μF 16V
C26	C1ARY-227APA	Electrolytic 220 μF 10V
C27,28	C1HRE-107A	Electrolytic 100 μF 50V
C29,30	C1VRE-227A	Electrolytic 220 μF 35V
C31,32	C1ERY-107APA	Electrolytic 100 μF 25V

SEMICONDUCTORS		
D01,02	202 5 2470 13540	Diode, DS-135
D03	DNN-RD5R6EB2	Diode, RD5.6EB2
D04	202 5 3210 20020	Diode, GZA20U
D05	DNN-RD4R3EB1	Diode, RD4.3EB1
D06	202 5 2300 017101	Diode, DS-17
D07	202 5 2300 018101	Diode, DS-18
D08	202 5 3210 05610	Diode, GZA5.6L
D09,10	202 5 3210 24010	Diode, GZA24L
D11	202 5 2320 131101	Diode, DS131
D12	202 5 3210 06220	Diode, GZA6.2U
D13,14	205 5 9040 44210	Diode, DS-442
IC01	ITT-TA78L024AP	IC, TA78L024AP
IC02	IAA-FS-7812M	IC, FS-7812M
Q01,02	203 5 6830 43850	TR 2SD438 E, F 03
Q04	203 5 6840 56050	TR 2SB560 E, F
Q05	203 5 5000 53660	TR 2SC536 F, G
Q06	TNN-2SD794-Q	TR 2SD794 Q, R

RESISTORS					
R01	R2EDPJ4R7A	Carbon	4.7	1/4W	±5%
R02	R2EDZJ102APA	Carbon	1k	1/4W	±5%
R03	R2EDZJ103APA	Carbon	10k	1/4W	±5%
R04	R2EDZJ221APA	Carbon	220	1/4W	±5%
R05	R2HXB391A	Oxide Metal Film	390	1/2W	±5%
R06	R2EDZJ272APA	Carbon	2.7k	1/4W	±5%
R07	R2HZPK2R2A	Fuse	2.2	1/2W	±10%
R08	R2EDZJ101APA	Carbon	100	1/4W	±5%
R09	R2HXB561A	Oxide Metal Film	560	1/2W	±5%
R10	R2EDPJ2R2A	Carbon	2.2	1/4W	±5%
R11	R2EDZJ101APA	Carbon	100	1/4W	±5%
R12	R2EDZJ102APA	Carbon	1k	1/4W	±5%
R13	R2EDZJ471APA	Carbon	470	1/4W	±5%
R14	R2HZPKR47A	Fuse	0.47	1/2W	±10%
R15	R2EDZJ561APA	Carbon	560	1/4W	±5%
R16	R2EDZJ102APA	Carbon	1k	1/4W	±5%
R17,18	R2HZPK471A	Fuse	470	1/2W	±10%
R19,20 21,22	R2EDZJ102APA	Carbon	1k	1/4W	±5%

**L.E.D. DRIVE P.C.B. Assy
131 0 4001 05661**

Ref. No.	Parts Number	Description
VR01,02	4 2222 01400	VR 10k-B
VR03,04	4 2222 00990	VR 1k-B

PARTS LIST (Continued)

PHONO EQ P.C.B. Assy
131 0 4001 05700

Ref. No.	Parts Number	Description
CAPACITORS		
C01,02 03,04	C1HRY-106APA	Electrolytic 10 μ F 50V
C05,06	C1HRY-105APA	Electrolytic 1 μ F 50V
C07,08	C1ERY-475APA	Electrolytic 4.7 μ F 25V
SEMICONDUCTORS		
D01,02 03,04	205 5 9040 44210	Diode, DS-442
IC01,02	206 5 2441 40910	IC, LB1409
Q01,02	203 5 6850 40050	TR 2SD400 E, F
Q03	203 5 7252 27450	TR 2SC2274 E, F
RESISTORS		
R01,02	R3DXBJ391A	Oxide Metal Film 390 2W \pm 5%
R03,04	R3AXBJ121A	Oxide Metal Film 120 1W \pm 5%
R05,06	R2EDZJ103APA	Carbon 10k 1/4W \pm 5%
R07,08	R2EDZJ102APA	Carbon 1k 1/4W \pm 5%
R09,10	R2EDZJ101APA	Carbon 100 1/4W \pm 5%
R11,12 13,14	R2EDZJ223APA	Carbon 22k 1/4W \pm 5%
R15,16	R2EDZJ103APA	Carbon 10k 1/4W \pm 5%
R17,18	R2EDZJ823APA	Carbon 82k 1/4W \pm 5%
R19,20	R2EDZJ183APA	Carbon 18k 1/4W \pm 5%
R21,22	R3DXBJ330A	Oxide Metal Film 33 2W \pm 5%
R23,24 25,26 27	R2HXB121A	Oxide Metal Film 120 1/2W \pm 5%
R28	R2EDZJ102APA	Carbon 1k 1/4W \pm 5%

HEADPHONE JACK P.C.B. Assy
131 0 4001 05671

Ref. No.	Parts Number	Description
	4 2352 00800	Headphone Jack 3P

SP TERMINAL 1 P.C.B. Assy
131 0 4001 05681

Ref. No.	Parts Number	Description
	4 2372 00090	SP Terminal 4P

SP TERMINAL 2 P.C.B. Assy
131 0 4001 05691

Ref. No.	Parts Number	Description
	4 2372 00090	SP Terminal 4P

Ref. No.	Parts Number	Description
	4 2222 01860	VR 150k-Ax2, 250k-MN
	4 2312 04660	Switch Push 1Key
	4 2312 04690	Switch Push 8Key
	4 2352 00780	DIN Socket 5P
	4 2359 23180	Socket 4P
	4 2359 23220	RCA 6P Jack
	4 2369 22750	Plug 7P
CAPACITORS		
C01,02	C1HFYK103APA	Mylar 0.01 μ F 50V \pm 10%
C03	C0JRY-227APA	Electrolytic 220 μ F 6.3V
C04,05	C0JRY-227AP	Electrolytic 220 μ F 6.3V
C06	C0JRY-227APA	Electrolytic 220 μ F 6.3V
C07	C1ARY-476APA	Electrolytic 47 μ F 10V
C08	C1ARY-476AP	Electrolytic 47 μ F 10V
C09,10	C1ARY-476APA	Electrolytic 47 μ F 10V
C11,12	C1ERY-475LPA	Electrolytic 4.7 μ F 25V
C13,14	C0JRY-227AP	Electrolytic 220 μ F 6.3V
C15,16	C0JRY-227APA	Electrolytic 220 μ F 6.3V
C17,18	C1ARY-227APA	Electrolytic 220 μ F 10V
C19,20	C1ARY-476APA	Electrolytic 47 μ F 10V
C21,22	C1HRY-335LPA	Electrolytic 3.3 μ F 50V
C23,24	C1HCZJ560SPA	Ceramic 56 pF 50V \pm 5%
C25,26	C0JRY-227APA	Electrolytic 220 μ F 6.3V
C27,28	C1HCZJ101SPA	Ceramic 100 pF 50V \pm 5%
C29,30	C1HCZJ220SPA	Ceramic 22 pF 50V \pm 5%
C31,32	C1HFRJ183A	Mylar 0.018 μ F 50V \pm 5%
C33,34	C1HFRJ472A	Mylar 0.0047 μ F 50V \pm 5%
C35,36	C1HCZK331BPA	Ceramic 330 pF 50V \pm 10%
C37,38	C1HRY-475LPA	Electrolytic 4.7 μ F 50V
C39,40	C1HCYK181APA	Ceramic 180 pF 50V \pm 10%
C41,42	C1HFYK473APA	Mylar 0.047 μ F 50V \pm 10%
C43,44 45,46 47	C1ECZN103XPA	Ceramic 0.01 μ F 25V \pm 30%
C48,49	C1ERE-227A	Electrolytic 220 μ F 25V

SEMICONDUCTORS

D01,02	DNN-RD7R5EB2	Diode, RD7.5EB2
D03,04	205 5 9040 44210	Diode, DS-442
IC01,02	IKK-HA1457	IC, HA1457
Q01,02	TMM-2SC2385-F	TR 2SC2385 F, G, H
Q03,04	TMM-2SA978-F	TR 2SA978 F, G, H
Q05	203 5 6850 40050	TR 2SD400 E, F
Q06	203 5 6860 54450	TR 2SB544 E, F
Q07,08	INN-2SK104--J	TR 2SK104 J

RESISTORS

R01,02	R2EDZJ8R2APA	Carbon 8.2 1/4W \pm 5%
R03,04	R2EDZJ681APA	Carbon 680 1/4W \pm 5%
R05,06 07,08 09,10	R2EDZJ182APA	Carbon 1.8k 1/4W \pm 5%
R11,12	R2EDZJ221APA	Carbon 220 1/4W \pm 5%
13,14		
R15,16	R2EDZJ330APA	Carbon 33 1/4W \pm 5%
17,18		
R19,20	R2EDZJ223APA	Carbon 22k 1/4W \pm 5%

PARTS LIST (Continued)

Ref. No.	Parts Number	Description
RESISTORS		
R21,22 23,24	R2EDZJ101APA	Carbon 100 1/4W ±5%
R25,26	R2EDZJ104APA	Carbon 100k 1/4W ±5%
R27,28	R2EDZJ471APA	Carbon 470 1/4W ±5%
R29,30	R2EDZJ104APA	Carbon 100k 1/4W ±5%
R31,32	R2EDZJ331APA	Carbon 330 1/4W ±5%
R33,34	R2EDZJ184APA	Carbon 180k 1/4W ±5%
R35,36	R2EDZJ153APA	Carbon 15k 1/4W ±5%
R39,40	R2EDZJ471APA	Carbon 470 1/4W ±5%
R41,42	R2EDZJ473APA	Carbon 47k 1/4W ±5%
R43,44	R2EDZJ221APA	Carbon 220 1/4W ±5%
R45,46	R2EDZJ472APA	Carbon 4.7k 1/4W ±5%
R47,48	R2EDZJ822APA	Carbon 8.2k 1/4W ±5%
R49,50	R2EDZJ334APA	Carbon 330k 1/4W ±5%
R51,52	R2EDZJ222APA	Carbon 2.2k 1/4W ±5%
R53	R2EDZJ102APA	Carbon 1k 1/4W ±5%

TONE AMP P.C.B. Assy 131 0 4001 05710

Ref. No.	Parts Number	Description
	4 2222 01341	VR 100k-Cx2
	4 2312 04670	Switch Push 2Key
	4 2312 04680	Switch Push 3Key
CAPACITORS		
C01,02	C1HRY-335LPA	Electrolytic 3.3 μF 50V
C03,04	C1HCYK560APA	Ceramic 56 pF 50V ±10%
C05,06	C1HCYK270APA	Ceramic 27 pF 50V ±10%
C07,08	C1HCYD100APA	Ceramic 10 pF 50V ±0.5%
C09,10	C1HCYK101APA	Ceramic 100 pF 50V ±10%
C11,12	C1HRY-225APA	Electrolytic 2.2 μF 50V
C13,14	C1HRY-475LPA	Electrolytic 4.7 μF 50V
C15,16	C1ERY-475APA	Electrolytic 4.7 μF 25V
C17,18	C1HFKY333APA	Mylar 0.033 μF 50V ±10%
C19,20	C1HFRJ184ML	Mylar 0.18 μF 50V ±5%
C21,22	C1HFKY333APA	Mylar 0.033 μF 50V ±10%
C23,24	C1HFRJ184ML	Mylar 0.18 μF 50V ±5%
C25,26	C1HFKY222AP	Mylar 0.0022 μF 50V ±10%
C27,28	C1HFKY123APA	Mylar 0.012 μF 50V ±10%
C29,30	C1HFKY222APA	Mylar 0.0022 μF 50V ±10%
C31,32	C1HFKY103APA	Mylar 0.01 μF 50V ±10%
C33,34	C1HRY-475APA	Electrolytic 4.7 μF 50V
C35,36	C1HFKY223APA	Mylar 0.022 μF 50V ±10%
C37,38	C1HCYK181APA	Ceramic 180 pF 50V ±10%
C39,40 41,42	C1HFRJ184ML	Mylar 0.18 μF 50V ±5%
C43,44	C1HRY-225LPA	Electrolytic 2.2 μF 50V
C45,46	C1ERE-227A	Electrolytic 220 μF 25V
C47	C1HRY-474APA	Electrolytic 0.47 μF 50V

SEMICONDUCTORS

IC01,02 IKK-HA1457 IC, HA1457

Ref. No.	Parts Number	Description
RESISTORS		
R01,02	R2EDZJ471APA	Carbon 470 1/4W ±5%
R03,04 05,06	R2EDZJ394APA	Carbon 390k 1/4W ±5%
R07,08	R2EDZJ104APA	Carbon 100k 1/4W ±5%
R09,10	R2EDZJ473APA	Carbon 47k 1/4W ±5%
R11,12 13,14	R2EDZJ471APA	Carbon 470 1/4W ±5%
R15,16	R2EDZJ123APA	Carbon 12k 1/4W ±5%
R17,18	R2EDZJ274APA	Carbon 270k 1/4W ±5%
R21,22	R2EDZJ222APA	Carbon 2.2k 1/4W ±5%
R25,26	R2EDZJ104APA	Carbon 100k 1/4W ±5%
R27,28	R2EDZJ222APA	Carbon 2.2k 1/4W ±5%
R29,30	R2EDZJ393APA	Carbon 39k 1/4W ±5%
R31,32	R2EDZJ105APA	Carbon 1M 1/4W ±5%
R33,34	R2EDZJ104APA	Carbon 100k 1/4W ±5%
R35,36	R2EDZJ221APA	Carbon 220 1/4W ±5%
R37	R2EDZJ102APA	Carbon 1k 1/4W ±5%

L.E.D. LAMP P.C.B. Assy 131 0 4001 05720

Ref. No.	Parts Number	Description
	4 6122 01910	Lamp Assy
SEMICONDUCTORS		
D01,02 03,04 05,06 07,08 09,10 11,12 13,14 15,16 17,18	DYY-SLR-54GG	Diode, SLR-54GG (LED)
D19,20	202 5 2470 13540	Diode, DS-135
RESISTORS		
R01,02 03,04 05,06 07,08 09,10 11,12 13,14 15,16 17,18	R2EDZJ101APA	Carbon 100 1/4W ±5%

POWER INDICATOR P.C.B. Assy 131 0 4001 06611

Ref. No.	Parts Number	Description
SEMICONDUCTORS		
D01	DYY-SLR-54UR	Diode, SLR-54UR (LED)
RESISTORS		
R01	R2EDZJ272APA	Carbon 2.7k 1/4W ±5%

POINT TO POINT WIRING DIAGRAM (TOP VIEW)

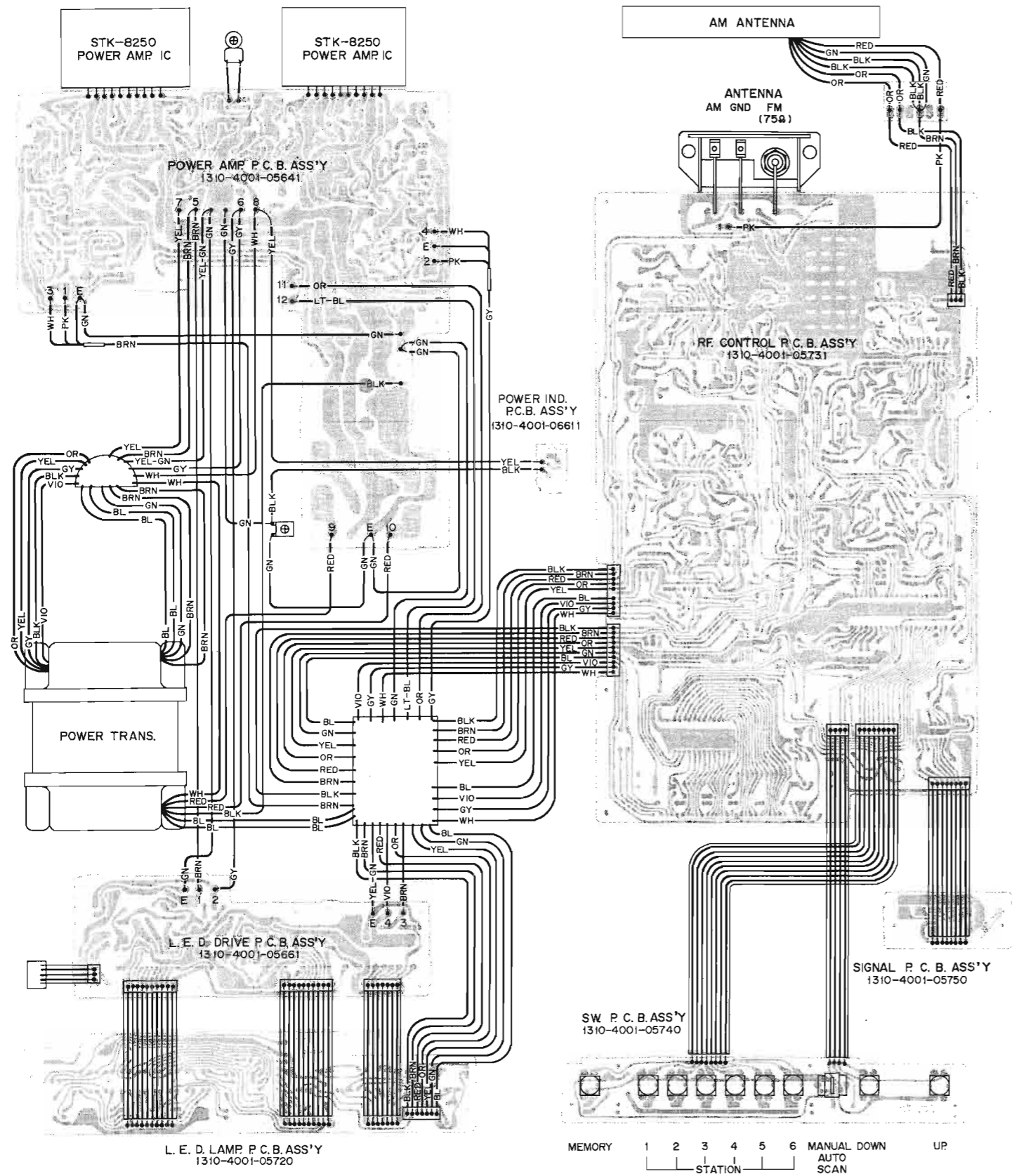

POINT TO POINT WIRING DIAGRAM (BOTTOM VIEW)

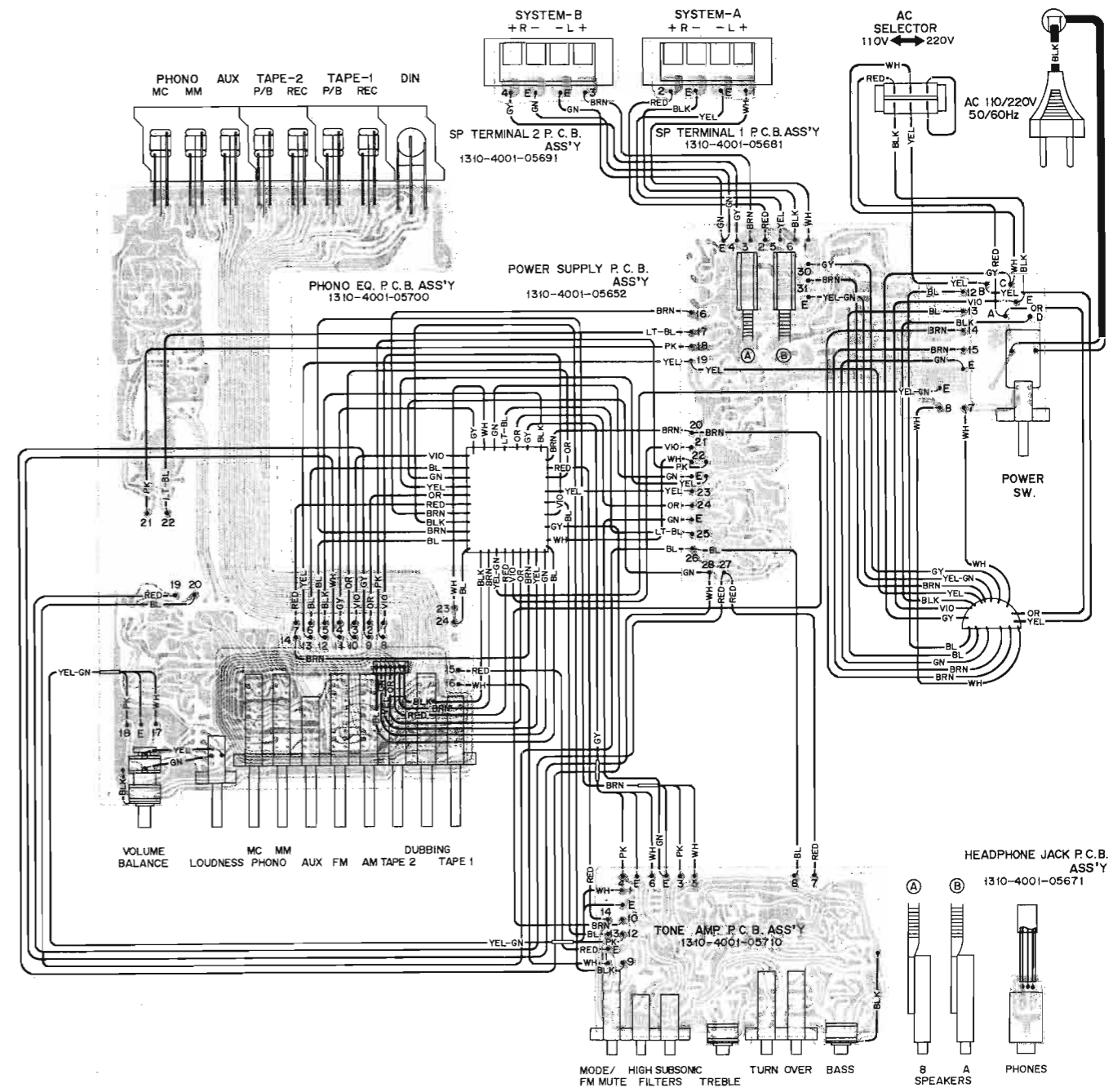

SCHEMATIC DIAGRAM

(RF CONTROL P.C.B.)

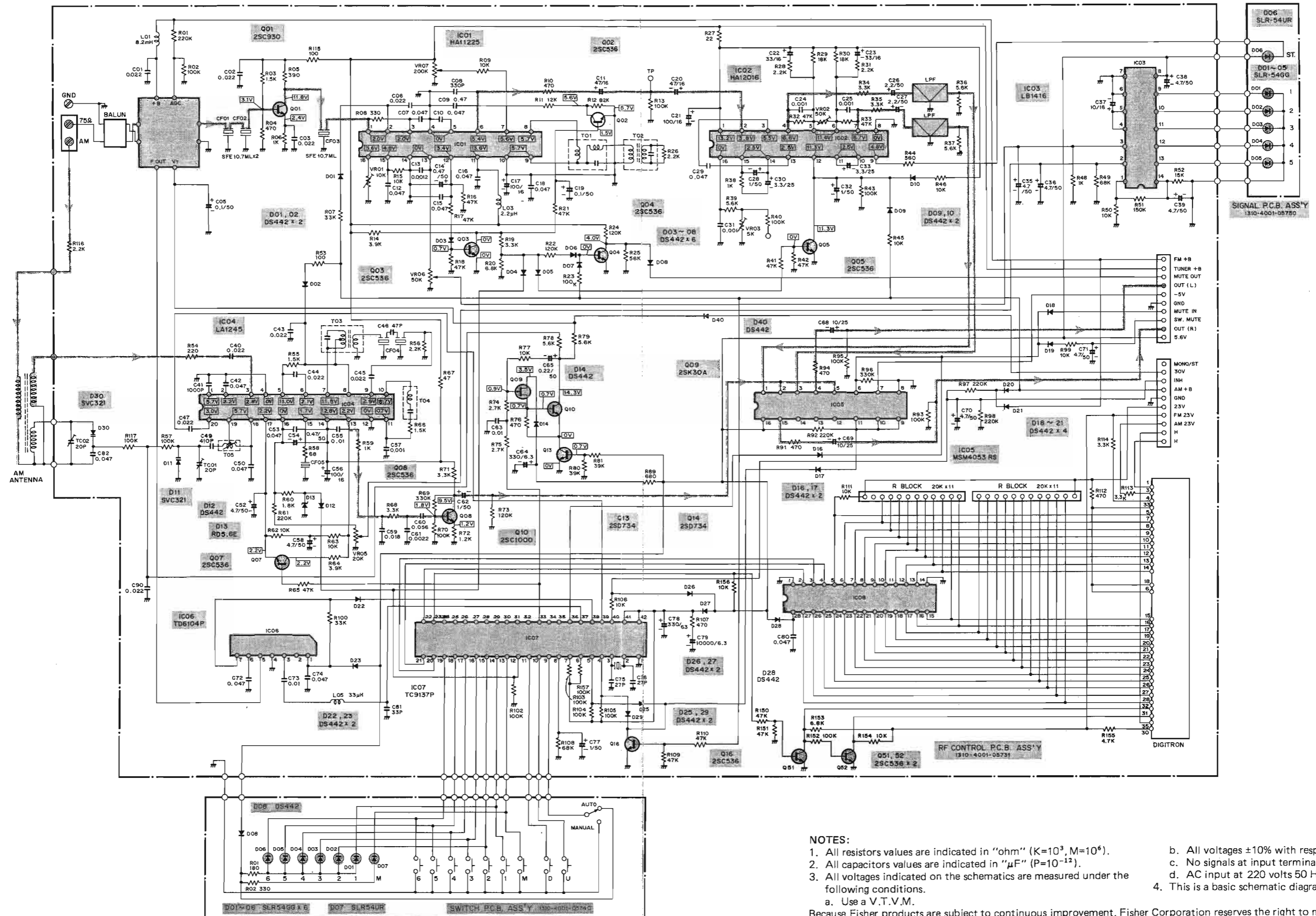

NOTES:

1. All resistors values are indicated in "ohm" ($K=10^3, M=10^6$).
 2. All capacitors values are indicated in " μF " ($P=10^{-12}$).
 3. All voltages indicated on the schematics are measured under the following conditions.
 - a. Use a V.T.V.M.
 4. This is a basic schematic diagram.
 - b. All voltages $\pm 10\%$ with respect to chassis ground
 - c. No signals at input terminals
 - d. AC input at 220 volts 50 Hz
- Because Fisher products are subject to continuous improvement, Fisher Corporation reserves the right to make any changes or modifications without notice.

SCHEMATIC DIAGRAM

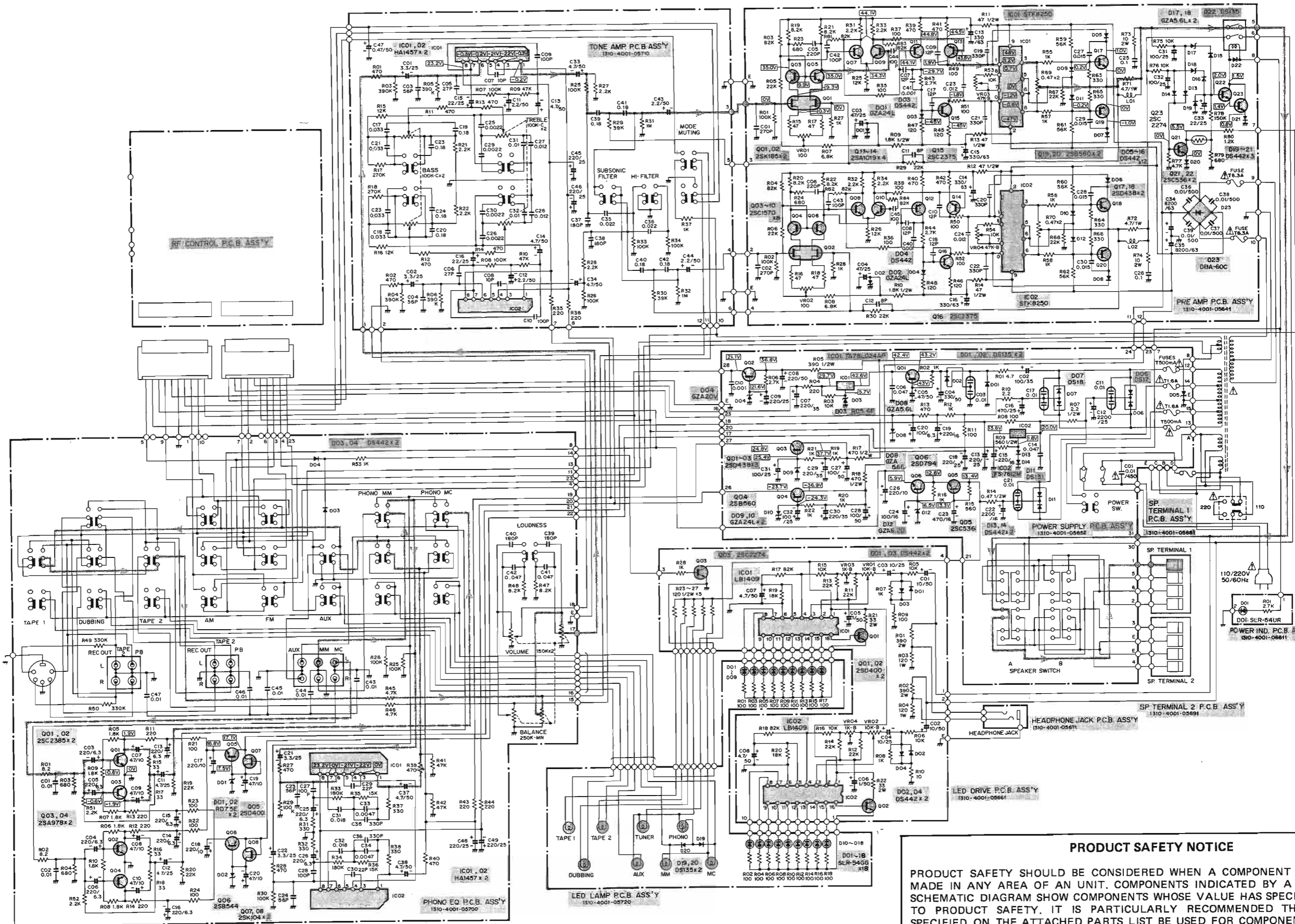

PRODUCT SAFETY NOTICE

PRODUCT SAFETY SHOULD BE CONSIDERED WHEN A COMPONENT REPLACEMENT IS MADE IN ANY AREA OF AN UNIT. COMPONENTS INDICATED BY A MARK IN THIS SCHEMATIC DIAGRAM SHOW COMPONENTS WHOSE VALUE HAS SPECIAL SIGNIFICANCE TO PRODUCT SAFETY. IT IS PARTICULARLY RECOMMENDED THAT ONLY PARTS SPECIFIED ON THE ATTACHED PARTS LIST BE USED FOR COMPONENT REPLACEMENT POINTED OUT BY THE MARK.

FRONT END SCHEMATIC DIAGRAM

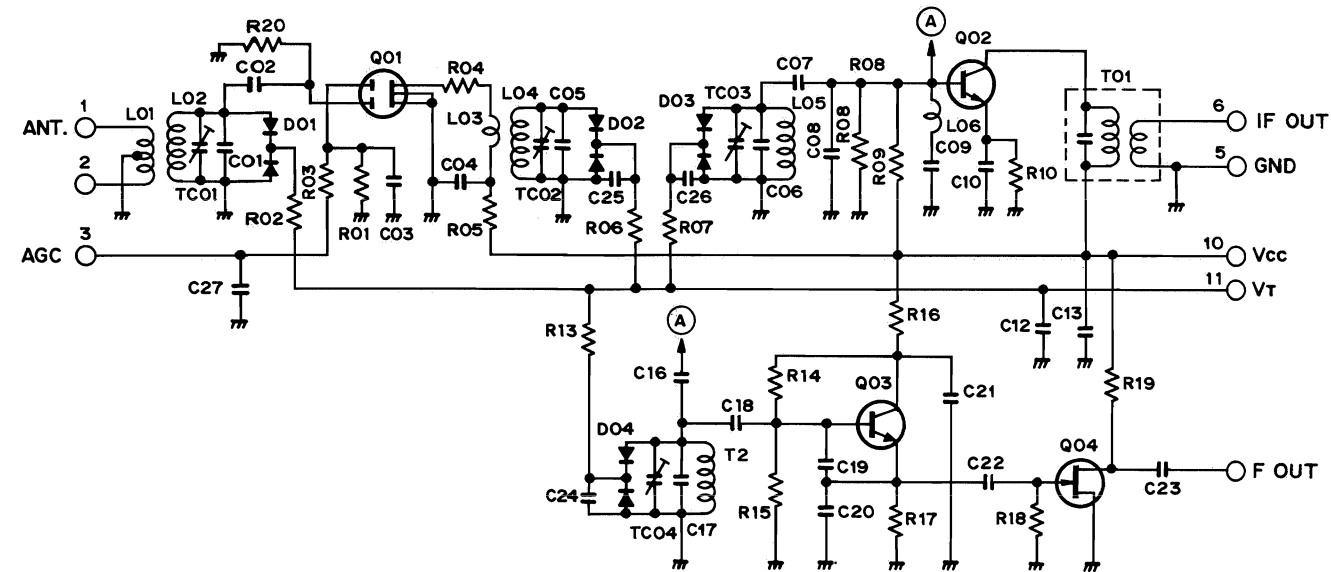

FISHER

Service/Ersatzteillager:
 FISHER HiFi Europa Vertriebs-GmbH
 Schönstraße 80, 8000 München 90
 Telefon 089/2379-7
 Telex 5-212384 D
 Wenden Sie sich bitte mit technischen
 Fragen an diese Adresse.

Verwaltung, Verkauf und Auslieferungslager:
 FISHER HiFi Europa Vertriebs-GmbH
 Truderingerstraße 13, 8000 München 80
 Telefon 089/4145-0
 Telex 5-24665 D
 5-24033 D