

Stereophonic

**THE FISHER
REGENT**

SERVICE

MANUAL

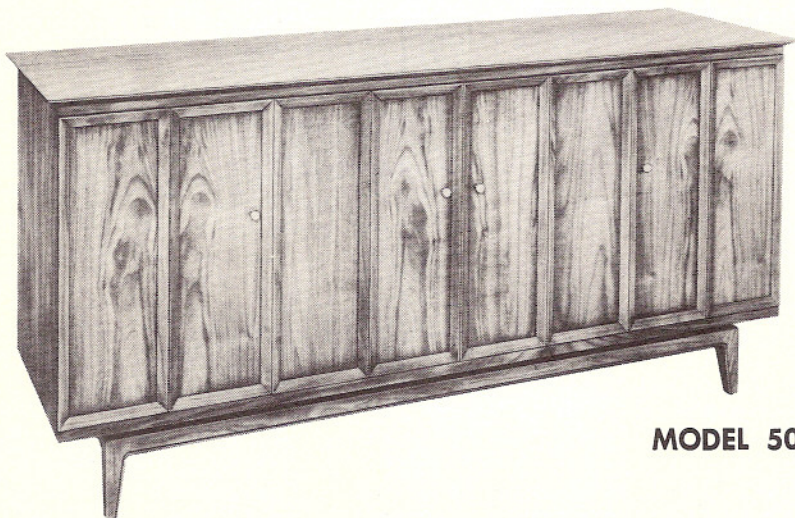

MODEL 5000

PRICE: \$1.00

FISHER RADIO CORPORATION • NEW YORK



THE FISHER 5000



PARTS DESCRIPTION LIST • TUNER

CAPACITORS

10% tolerance for all fixed capacitors, unless otherwise noted or marked GMV (guaranteed minimum value). All capacitors not marked uf are pf (uf).
A — 40uf, 250V
B — 40uf, 250V
C — 40uf, 300V
D — 40uf, 300V

Symbol	Description	Part No.	Symbol	Description	Part No.
C1	Ceramic, 4, NPO, 1000V	C50070-36	C64	Ceramic, 5000, +80 — 20%, 500V	C50089-6
C2, 3	Mylar, .1uf, 250V	C50197-54	C65	Ceramic, 100, N1500, 1000V	C50070-6
C4	Ceramic, 10, NPO, 1000V	C50070-11	C66, 67, 68	Ceramic, 5000, +80 — 20%, 500V	C50089-6
C5	Ceramic, 47, 5%, N750, 1000V	C50070-29	C69	Ceramic, 2700, 1000V	C50072-17
C6	Ceramic, .02uf, +80 — 20%, 500V	C50089-4	C70	Ceramic, 7, NPO, 1000V	C50070-20
C7, 8	Ceramic, 5000, 20%, 500V	C50089-1	C71	Ceramic, 5000, +80 — 20%, 500V	C50089-6
C9, 10	Ceramic, 390, 1000V	C50072-6	C72	Ceramic, Feedthru, 1000, GMV	C592-187
C11	Ceramic, 1000, GMV, 500V	C50089-2	C73	Ceramic, 5000, +80 — 20%, 500V	C50089-6
C12	Ceramic, Feedthru, 1000, GMV	C592-187	C74	Ceramic, .02uf, GMV, 1000V	C50071-6
C13	Ceramic, .02uf, +80 — 20%, 500V	C50089-4	C75	Ceramic, 12, NPO, 1000V	C50070-12
C14	Ceramic, Feedthru, 1000, GMV	C592-187	C76	Ceramic, .05uf, +80 — 20%, 100V	C50073-2
C15	Ceramic, 7 ± .5, NPO, 500V	CC20CJ070D5	C77	Electrolytic, 2uf, 70V	C721-142
C16	Electrolytic, 20uf, 250V	C746-145	C78	Ceramic, 2700, 1000	C50072-17
C17, 18	Ceramic, 39, N1500, 1000V	C50070-17	C79	Ceramic, 5000, +80 — 20%, 500V	C50089-6
C19	Ceramic, 1000, GMV, 500V	C50089-2	C80	Ceramic, .02uf, GMV, 1000V	C50071-6
C20	Ceramic, Trimmer	C662-123	C81	Electrolytic, .5uf, 350V	C50283-7
C21	Ceramic, 100, GMV, N1500, 1000V	C50070-5	C82, 83, 84	Ceramic, 330, 1000V	C50072-1
C22	Ceramic, 56, 5%, N1500, 1000V	C50070-38	C85	Polystyrene, 2500, 5%, 125V	CP50394-9
C23	Variable, FM-AM	C965-115	C86	Molded, .01uf, 20%, 600V	C2747
C24	Ceramic, 56, 5%, N1500, 1000V	C50070-38	C87	Electrolytic, 8uf, 50V	C629-138
C25	Ceramic, .68, 500V	C50077-6N	C88	Mylar, .1uf, 125V	C50435-7
C26	Ceramic, Trimmer	C662-123	C89	Ceramic, .05uf, +80 — 20%, 100V	C50073-2
C27	Ceramic, 8 ± .5, NPO, 500V	CC20CJ080D5	C90	Ceramic, Feedthru, 1000, GMV	C592-187
C28	Ceramic, 68, N750, 500V	CC20UJ680K5	C91	Ceramic, .05uf, +80 — 20%, 100V	C50073-2
C29	Ceramic, .02uf, +80 — 20%, 500V	C50089-4	C92	Polystyrene, 470, 2.5%, 125V	CP50394-6
C30, 31	Ceramic, 100, N1500, 1000V	C50070-6	C93	Ceramic, 2700, 1000V	C50072-17
C32	Ceramic, Trimmer	C662-123	C94, 95	Mylar, .1uf, 125V	C50435-7
C33	Ceramic, 24, 5%, N150, 1000V	C50070-8			
C34	Ceramic, 100, 5%, N1500, 1000V	C50070-19			
C35	Polystyrene, 470, 2.5%, 125V	CP50394-6			
C36	Ceramic, 8, NPO, 1000V	C50070-14			
C37	Ceramic, 1000, 1000V	C50072-3			
C38	Ceramic, 8 ± .5, N330, 500V	CC20S080D5			
C39, 40	Ceramic, Feedthru, 1000 GMV	C592-187			
C41	Polystyrene, 470, 2.5%, 125V	CP50394-6			
C42	Ceramic, 5000, +80 — 20%, 500V	C50089-6			
C43	Ceramic, 2700, 1000V	C50072-17			
C44	Ceramic, 5000, +80 — 20%, 500V	C50089-6			
C45	Polystyrene, 470, 2.5%, 125V	CP50394-6			
C46	Ceramic, 560, 1000V	C50072-14			
C47	Ceramic, .02uf, +80 — 20%	C50089-4			
C48	Ceramic, 10, 5%, NPO, 1000V	C50070-39			
C49	Ceramic, 5000, +80 — 20%, 500V	C50089-6			
C50	Ceramic, 1, 20%, 1000V	C50070-1			
C51	Ceramic, 100, N1500, 1000V	C50070-6			
C52	Polystyrene, 1000, 5%, 125V	CP50394-7			
C53	Ceramic, .05uf, +80 — 20%, 100V	C50073-2			
C54	Ceramic, 24, 5%, N150, 1000V	C50070-8			
C55	Ceramic, 5000, +80 — 20%, 500V	C50089-6			
C56	Ceramic, 2700, 1000V	C50072-17			
C57	Ceramic, .02uf, GMV, 1000V	C50071-6			
C58, 59, 60	Ceramic, 5000, +80 — 20%, 500V	C50089-6			
C61	Ceramic, .05uf, +80 — 20%, 100V	C50073-2			
C62	Ceramic, 100, N1500, 1000V	C50070-6			
C63	Electrolytic, 4 section:	C670-125B			

RESISTORS AND POTENTIOMETERS

In ohms, 5% tolerance, 1/8 watt, unless otherwise noted. K=Kilohms, M=Megohms.

Symbol	Description	Part No.
R1	Composition, 3.3, 10%, 1/2 W	RC20BF3R3K
R2	Composition, 270, 10%, 1/2 W	RC20BF271K
R3	Composition, 2.7K, 10%, 1/2 W	RC20BF272K
R4	Dep. Carbon, 1.5M, 1/3 W	R33DC155J
R5, 6	Dep. Carbon, 100K, 1/3 W	R33DC104J
R7	Composition, 100K, 10%, 1/2 W	RC20BF104K
R8	Composition, 270, 10%, 1/2 W	RC20BF271K
R9	Dep. Carbon, 1.8M, 1/3 W	R33DC185J
R10, 11	Composition, 22M, 10%, 1/2 W	RC20BF226K
R12	Composition, 100, 10%, 1/2 W	RC20BF101K
R13	Dep. Carbon, 47	R12DC470J
R14	Dep. Carbon, 1.8M, 1/3 W	R33DC185J
R15, 16	Composition, 150K, 10%, 1/2 W	RC20BF154K
R17	Composition, 47K, 10%, 1/2 W	RC20BF473K
R18	Dep. Carbon, 100K	R12DC104J
R19	Dep. Carbon, 100K, 1/3 W	R33DC104J
R20	Composition, 680, 10%, 1/2 W	RC20BF681K
R21	Dep. Carbon, 100K, 1/3 W	R33DC104J
R22	Composition, 680, 10%, 1/2 W	RC20BF681K
R23, 24	Dep. Carbon, 100K, 1/3 W	R33DC104J
R25	Dep. Carbon, 330K	R12DC334J
R26	Composition, 2.2K, 10%, 1/2 W	RC20BF222K
R27, 28	Dep. Carbon, 470K, 1/3 W	R33DC474J
R29	Potentiometer, 500K, Left Output Level	R50103-6

PARTS DESCRIPTION LIST • TUNER

R30	Dep. Carbon, 560K	R12DC564J	R95	Composition, 820K, 10%, 1/2 W	RC20BF824K
R31	Dep. Carbon, 22K	R12DC223J	R96	Dep. Carbon, 15K	R12DC153J
R32	Dep. Carbon, 470K	R12DC474J	R97	Dep. Carbon, 470K	R12DC474J
R33	Dep. Carbon, 27	R12DC270J	R98	Composition, 330	RC20BF331K
R34	Dep. Carbon, 3.9M, 1/3 W	R33DC395J	R99	Dep. Carbon, 1.8M, 1/3 W	R33DC185J
R35	Composition, 18K, 10%, 1W	RC30BF183K	R100	Dep. Carbon, 1K	R12DC102J
R36	Dep. Carbon, 2.7K	R12DC272J	COILS, CHOKES AND TRANSFORMERS		
R37	Composition, 1K, 10%, 1/2 W	RC20BF102K	Symbol	Description	Part No.
R38	Dep. Carbon, 47K	R12DC473J	L1	AM Loop Antenna	L990-132
R39	Composition, 1K, 10%, 1/2 W	RC20BF102K	L2	Coil, FM Antenna	L965-119
R40	Composition, 3.3K, 10%, 1W	RC30BF332K	L3	Transformer, AM RF	L50210-35
R41	Composition, 150, 10%, 1/2 W	RC20BF151K	L4	Choke, 1.5 Microhenry	L50066-4
R42	Composition, 27K, 10%, 1/2 W	RC20BF273K	L5	Coil, FM RF	L965-116
R43	Dep. Carbon, 47K	R12DC473J	L6	Coil, FM Mixer	L965-117
R44	Composition, 1K, 10%, 1/2 W	RC20BF102K	L7	Choke, 1 Microhenry	L50210-22
R45	Composition, 180, 10%, 1/2 W	RC20BF181K	L8	Coil, AM OSC.	L50210-28
R46	Dep. Carbon, 820K	R12DC824J	L9	Coil, FM OSC Assembly	AS965-120
R47	Dep. Carbon, 47K	R12DC473J	L10, 11,		
R48	Composition, 27K, 10%, 1/2 W	RC20BF273K	12	Choke, 1 Microhenry	L50066-2
R49	Potentiometer, 500K, Right Output Level	R50703-6	L13	Coil, 10K Filter	L644-120
R50	Composition, 1K, 10%, 1/2 W	RC20BF102K	L14	Coil, Muting OSC	L50210-22
R51	Composition, 82K, 10%, 1/2 W	RC20BF823K	L15	Choke, 3.3 Microhenries	L50066-8
R52	Potentiometer, 100K, Muting	R50160-106	L16	Choke, 1 Microhenry	L50066-2
R53	Dep. Carbon, 47K	R12DC473J	L17, 18, 19,		
R54	Dep. Carbon, 27K	R12DC273J	20, 21, 22,		
R55	Dep. Carbon, 1.8K	R12DC182J	23, 24	Choke, Ferrite Bead	L592-189
R56	Dep. Carbon, 68K	R12DC683J	T1	Transformer, Power	T1016-115
R57	Composition, 68K, 10%, 1/2 W	RC20BF683K	Z1	Transformer, FM I.F.	ZZ50210-42
R58	Dep. Carbon, 1M	R12DC105J	Z2	Transformer, AM I.F.	ZZ50210-38
R59	Dep. Carbon, 15K	R12DC153J	Z3	Transformer, FM I.F.	ZZ50210-39
R60	Composition, 1K, 10%, 1/2 W	RC20BF102K	Z4	Transformer, AM I.F.	ZZ50210-38
R61	Dep. Carbon, 1M	R12DC105J	Z5	Transformer, FM I.F.	ZZ50210-2
R62	Dep. Carbon, 100K	R12DC104J	Z6	Transformer, AM I.F.	ZZ50210-40
R63	Dep. Carbon, 220K	R12DC224J	Z7, 8	Coil, FM Limiter	ZZ50210-6
R64	Composition, 2.2K, 10%, 1/2 W	RC20BF222K	Z9	Transformer, FM Ratio Detector	ZZ50210-9
R65	Dep. Carbon, 22K	R12DC223J	MISCELLANEOUS		
R66	Glass, 270, 10%, 3W	RPG3W271K	Symbol	Description	Part No.
R67	Dep. Carbon, 120	R12DC121J	CR1, 2, 3	Diode, Type 1112	V-1112
R68	Composition, 470K, 10%, 1/2 W	RC20BF474K	CR4	Selenium Rectifier Bridge	SR50253-4
R69	Glass, 270, 10%, 3W	RPG3W271K	CR5, 6, 7, 8	Diode, Type 1112	V-1112
R70	Composition, 56K, 10%	RC20BF563K	F1	Fuse, 1.2A, Slo-Blo	F1016-119
R71	Dep. Carbon, 1M	R12DC105J	I1, 2, 3	Bulb #47	I50009-1
R72	Composition, 1K, 10%, 1/2 W	RC20BF102K	I4	Bulb #470F	I50009-4
R73	Composition, 18K, 10%, 1/2 W	RC20BF183K	I5, 6	Bulb, Dial	I50082-6
R74	Composition, 150, 10%, 1/2 W	RC20BF151K	M1	Meter	M766-137
R75	Dep. Carbon, 1K	R12DC102J	RL1	Relay	K50314
R76	Dep. Carbon, 82K	R12DC823J	PC1	Printed Circuit	PC50434
R77, 78	Composition, 220, 10%, 1/2 W	RC20BF221K	S1	Switch, FM Antenna	S1016-117
R79	Dep. Carbon, 47K	R12DC473J	S2	Switch, AM Bandwidth	S1016-118
R80	Dep. Carbon, 270K	R12DC274J	S3	Switch, Selector	S1016-116
R81	Dep. Carbon, 820K	R12DC824J	S4	Switch, Muting	Part of R52
R82	Dep. Carbon, 56K	R12DC563J	S5	Switch, Filter	S1016-113
R83	Composition, 47K, 10%, 1/2 W	RC20BF473K	—	Dress Panel	AS1016-108
R84	Dep. Carbon, 820K	R12DC824J	—	FM Dipole	AS50227-1
R85	Composition, 1K, 10%, 1/2 W	RC20BF102K	—	Tube Shield, 7-Pin	E3330
R86, 87	Dep. Carbon, 820K	R12DC824J	—	Tube Shield, 9-Pin	E3287
R88	Dep. Carbon, 150K	R12DC154J	—	Knob	E50325-1
R89	Dep. Carbon, 100K	R12DC104J	—	Knob, Tuning	E50325-2
R90	Dep. Carbon, 470K	R12DC474J	—	Jewel, Red	I50162-1
R91	Composition, 1.5K, 5%, 1/2 W	RC20BF152J	—	Jewel, Yellow	I50162-2
R92	Composition, 1K, 5%, 1/2 W	RC20BF102J	—	Jewel, Green	I50162-4
R93	Composition, 270, 5%, 1/2 W	RC20BF271J			
R94	Dep. Carbon, 47K	R12DC473J			

FM-AM ALIGNMENT CHART • TUNER

AM

FM

STEPS	CHASSIS			SIGNAL GENERATOR			MEASURING INSTRUMENT	ALIGNMENT	
	AM BANDWIDTH	SELECTOR	STATION SELECTOR	COUPLING	FREQ.	MOD.	TYPE CONNECTION	ADJUST	INDICATION
1	SHARP	AM	Point of no signal and no interference	Audio Gen. with 1V output connected thru 100K resistor to junction of R53 and R54	10 KC	None	AC VTVM to Left Main output	—	Minimum output between 9.5 and 10.5 KC
2	SHARP	AM	Point of no signal and no interference	AM RF Gen. connected thru .01-uf cap. in series with hot lead to V9, Pin 7	455 KC	30% AM at 400 cps.	DC VTVM to the junction of R53 and R54	Z6, Z4, Z2 top & bottom	Maximum negative voltage
3	NORMAL	AM	Point of no signal and no interference	AM Sweep Gen. connected thru .01-uf cap. in series with hot lead to V9, Pin 7	455 KC	30 KC sweep	Scope to Left Main output	Z6 bottom	Adjust slightly for symmetrical curve
4	SHARP	AM	600 KC	AM Gen. connected thru 220-uuf cap. in series with hot lead to AM antenna terminal	600 KC	30% AM at 400 cps.	Scope to Left Main output. DC VTVM to the junction of R53 and R54	L8, L3, L1	Check for sine waveform and maximum negative voltage
5	SHARP	AM	1400 KC	AM Gen. connected thru 220-uuf cap. in series with hot lead to AM antenna terminal	1400 KC	30% AM at 400 cps.	Scope to Left Main output. DC VTVM to the junction of R53 and R54	C23J, C23G, C23D	Check for sine waveform and maximum negative voltage
6	Repeat steps 4 and 5 for proper dial calibration and maximum output.								
NOTE: For steps 1- to 3 remove Tube V1.									
1	FM Muting switch OFF	FM	Point of no signal and no interference	FM Generator connected to Pin 1 of V5	10.7 MC	None	Connect VTVM to TSP 3	Z7, Z8 top, Z9 bottom & top	Voltage between -15 and -30 volts. See Note 3.
2	FM Muting switch OFF	FM	Point of no signal and no interference	FM Generator connected to Pin 1 of V5	10.7 MC	None	Hot lead of DC VTVM to TSP 4. Ground lead of VTVM to junction of two series-connected 47K resistors wired between TSP 3 and gnd.	Z9 top	Zero reading on zero center scale
3	FM Muting switch OFF	FM	Point of no signal and no interference	FM Gen. connected to ungrounded tube shield of V2	10.7 MC	None	DC VTVM to TSP 2	Z5, Z3, Z1 top & bottom	With DC voltage between -0.5 and -1 volt, adjust for maximum
4	FM Muting switch OFF	FM	90 MC	FM Gen. connected thru two 120-ohm carbon resistors in series with lead to FM antenna terminals	90 MC	30% FM (22.5 KC Dev.) at 400 cps.	DC VTVM to TSP 2 and scope to Left Main output	L9, L6, L5, L2	Check for sine waveform and adjust for maximum negative voltage
5	FM Muting switch OFF	FM	1u6 MC	FM Gen. connected thru two 120-ohm carbon resistors in series with lead to FM antenna terminals	106 MC	30% FM (22.5 KC Dev.) at 400 cps.	DC VTVM to TSP 2 and scope to Left Main output	C32, C26, C20	Check for sine waveform and adjust for maximum negative voltage
6	Repeat steps 4 and 5 for proper dial calibration and maximum output.								

Read These Instructions With Extreme Care Before Attempting Alignment.

CHASSIS: Turn the station selectors completely counter-clockwise, without forcing. Dial pointer should be at zero mark on logging scale. If not, reset the dial pointer. Disconnect the external antennas and the AM antenna link. Swing AM Ferrite Loop antenna rearward to operating position. When using an oscilloscope for alignment, set the output level controls for no overload, as shown by the proper waveform shape. Set FM Antenna switch to NORMAL.

SIGNAL GENERATORS: The signal generator equipment must be able to supply the following: FM RF 22.5 KC deviation at 400 cps; AM RF modulated 30% at 400 cps; AM IF with 30 KC sweep for AM bandwidth adjustment; audio oscillator accurately calibrated for 1 and 10 KC audio output for testing the 10 KC AM whistle filter.

MEASURING INSTRUMENTS: DC VTVM, AC VTVM, and scope for alignment.

ALIGNMENT: Allow the chassis and test instruments to warm up for at least fifteen minutes. Adjust the line voltage for 117 volts AC, 50-60 cycles. Use fully insulated tools; a small screwdriver for all trimming capacitors; a K-tran tool for Z1, Z2, Z3, Z4, Z5 and Z6; a hex tool for Z7, Z8, Z9, L2, L3, L5, L6, L8, L9 and L14.

NOTES:

- 1 — For AM alignment short out C91.
- 2 — For calibrating both the AM and FM-RF, use as low an output voltage as possible from your signal generator.
- 3 — Decrease FM signal generator output while adjusting FM-IF transformers so that DC VTVM shows noted voltage.
- 4 — The center frequency should be kept constant for FM-IF, limiter and ratio detector alignment.
- 5 — If adjustment of muting oscillator is necessary, adjust it for 3 MC with a Grid-dip Meter.

ALIGNMENT INSTRUCTIONS • MULTIPLEX SECTION

STEPS	GENERATOR			INDICATOR	ALIGNMENT		
	CONNECTION	AUDIO FREQUENCY	RF MODULATION	TYPE & CONNECTION	ADJUST	INDICATION	NOTES
1	Audio oscillator connected to lug 1	80 KC—1 volt	None	AC VTVM to junction of C210 and R228	L100 (Use hex alignment tool)	Minimum voltage	
2	Multiplex generator audio output to lug 1 (See Note 1)	19 KC (± 5 cps) pilot tone, 100 mv	None	DC VTVM to T.S.P. 101	Z100 top and bottom (Use hex alignment tool)	Maximum voltage	1
3	Same as Step 2	19 KC pilot tone, 50 mv	None	Scope horiz. input to 19 KC output of gen.; vert. input to junction of C216 and R209. External sweep	Z101 (Use K-tran alignment tool)	Stable 2:1 Lissajous pattern. Disregard phase of pattern	1
4	Same as Step 2	19 KC	None	Same as Step 3	Vary generator 19 KC output from 50 to 200 mv	Lissajous pattern should remain stationary over the entire 150 mv range	1, 2
5	Same as Step 2	1000 cps on left (A) channel only, 1 volt rms (2.8 P-P)	None	AC VTVM and scope vert. input to channel A output lug. Internal sweep. DC VTVM to T.S.P. 101	Z100 top (Use hex tool)	Maximum indication on AC VTVM. Clean 1000 cps waveform on scope	1, 3
6	Same as Step 2	1000 cps on right (B) channel only, 1 volt rms (2.8 P-P)	None	Same as Step 5	MPX separation R215	Minimum reading on AC VTVM should be at least 33 db below reading obtained in Step 5	1
7	Same as Step 2	Same as Step 6	None	Move scope input and AC VTVM to channel B output lug	-----	Note and record voltage reading on AC VTVM	1
8	Same as Step 2	1000 cps on left (A) channel only, 1 volt rms (2.8 P-P)	None	Same as Step 7	-----	AC VTVM reading should be at least 33 db below reading observed in Step 7	1
9	Same as Step 2	8000 cps on right (B) channel only, 1 volt rms (2.8 P-P)	None	Same as Step 7	-----	AC VTVM reading should be the same as observed in Step 7	1
10	Same as Step 2	8000 cps on left (A) channel only, 1 volt rms (2.8 P-P)	None	Same as Step 7	-----	AC VTVM reading should be at least 18 db below reading observed in Step 9	1
11	Repeat Steps 9 and 10 with scope and AC VTVM connected to channel A output lug, but start with 8000 cps applied to left channel for first reading, then switch to right channel for second reading.						
12	Multiplex generator RF output to 300-ohm antenna terminals	1000 cps on left (A) channel only	100% (75 KC Dev.) No pre-emphasis	Move scope input and AC VTVM to channel A output lug	-----	Note and record voltage reading on AC VTVM	4
13	Same as Step 12	1000 cps on right (B) channel only	Same as Step 12	Same as Step 12	R215	Minimum reading on AC VTVM should be at least 33 db below reading observed in Step 12	4
14	Same as Step 12	8000 cps on left (A) channel only	Same as Step 12	Same as Step 12	-----	AC VTVM reading should be 10 db below reading observed in Step 12	4
15	Same as Step 12	8000 cps on right (B) channel only	Same as Step 12	Same as Step 12	-----	AC VTVM reading should be 28 db below reading observed in Step 12	4

NOTE: The above procedure is based on the use of the FISHER Model 300 Multiplex Generator.

1 — In steps 2 through 11, the audio output of the Multiplex Generator should be connected to lug 1 of the multiplex sub-chassis through a 12,000 ohm, ½-watt, carbon resistor, and a 180 uuf capacitor should be connected between lug 1 and ground. The wiring from the MPX TEST jack on the main chassis to lug 1 must be disconnected during Steps 2 through 11.

2 — The vertical amplitude of the Lissajous pattern will increase slightly

as the generator output is increased. This is a normal occurrence.

3 — If DC VTVM reading falls below -9 volts when maximum reading is obtained on the AC VTVM, readjust bottom of Z100, then repeat Step 5. Repeat this procedure until maximum AC VTVM reading is obtained with DC VTVM reading greater than -9 volts.

4 — Tune the FISHER to the RF output frequency of the Multiplex Generator.

SCHEMATIC DIAGRAM • MULTIPLEX SECTION • PARTS DESCRIPTION LIST

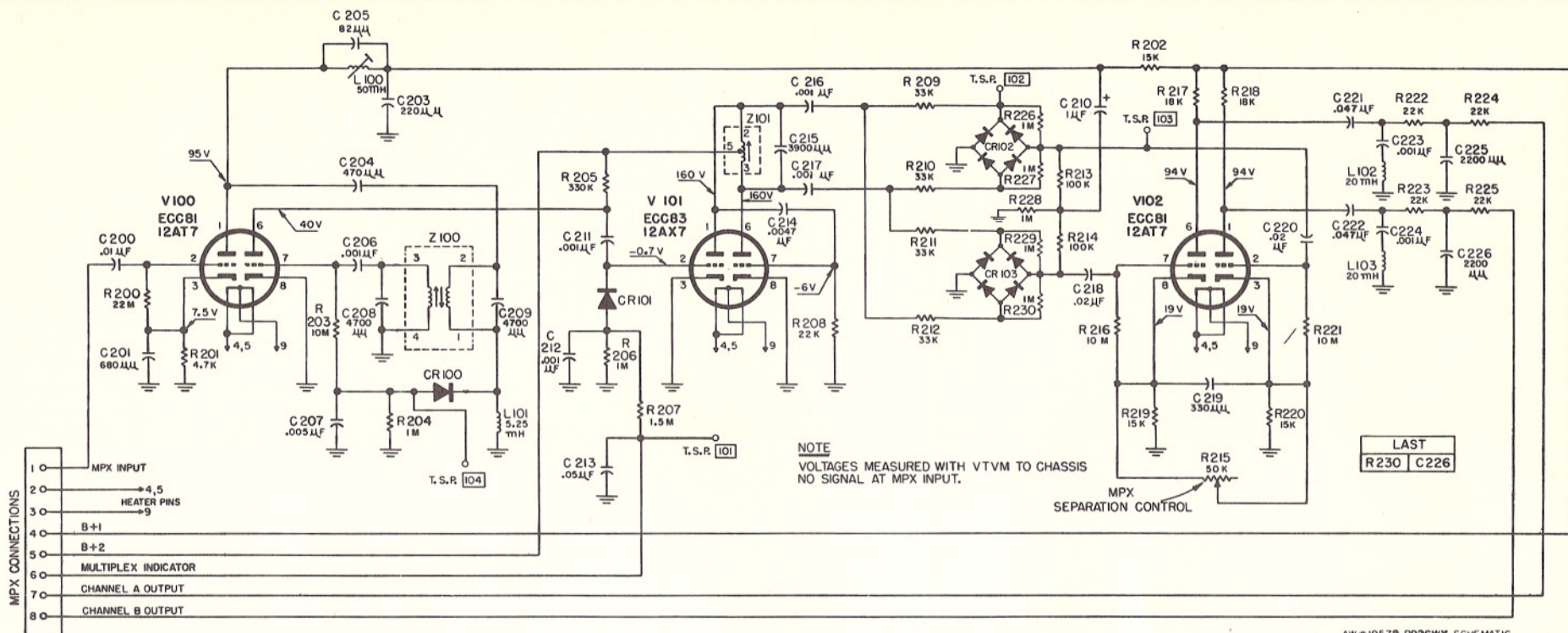

LAST
R230 C226

AW#1957B P926WX SCHEMATIC

CAPACITORS

10% tolerance for all fixed capacitors, unless otherwise noted or marked GMV (guaranteed minimum value). All capacitors not marked uf are pF (uuf).

Symbol	Description	Part No.
C200	Ceramic, .01uf, +80 -20%, 500V	C50089-7
C201	Ceramic, 680, 1000V	C50072-2
C203	Ceramic, 220, 1000V	C50183-3
C204	Polystyrene, 470, 5%, 500V	C50394-1
C205	Ceramic, 82, N1500, 1000V	C50070-7
C206	Ceramic, .001uf, GMV, 500V	C50089-2
C207	Ceramic, .005uf, +80 -20%, 500V	C50089-6
C208, 209	Mica, 4700, 5%, 500V	C50332-5
C210	Electrolytic, 1uf, 350V	C50283-3
C211, 212	Ceramic, .001uf, GMV, 500V	C50089-2
C213	Ceramic, .05uf, +80 -20%, 100V	C50073-2
C214	Mylar, .0047uf, 400V	C50197-25
C215	Mica, 3900, 5%, 500V	C50332-6
C216, 217	Ceramic, .001uf, GMV, 500V	C50089-2
C218	Ceramic, .02uf, 20%, 500V	C50089-5
C219	Ceramic, 330, 1000V	C50072-1

C220	Ceramic, .02uf, 20%, 500V
C221, 222	Mylar, .047uf, 10%, 250V
C223, 224	Ceramic, .001uf, 1000V
C225, 226	Ceramic, 2200, 1000V

RESISTORS AND POTENTIOMETERS

In ohms, 10% tolerance, 1/2 watt, unless otherwise noted. K=Kilohm, M=Megohm.

Symbol	Description	Part No.
R200	Composition, 22M	RC20BF226K
R201	Composition, 4.7K, 5%	RC20BF472J
R202	Composition, 15K, 5%	RC20BF153J
R203	Composition, 10M	RC20BF106K
R204	Dep. Carbon, 1M, 5%, 1/8 W	R12DC105J
R205	Dep. Carbon, 330K, 5%, 1/2 W	R33DC334J
R206	Dep. Carbon, 1M, 5%, 1/8 W	R12DC105J
R207	Dep. Carbon, 1.5M, 5%, 1/2 W	R33DC155J
R208	Dep. Carbon, 22K, 5%, 1/8 W	R12DC223J
R209, 210,		
211, 212	Dep. Carbon, 33K, 5%, 1/8 W	R12DC333J
R213, 214	Dep. Carbon, 100K, 5%, 1/8 W	R12DC104J

C50089-5
C50197-52
C50072-3
C50072-5

R215	Potentiometer, 50K, MPX-separation	R50150-4
R216	Composition, 10M	RC20BF106K
R217, 218	Dep. Carbon, 18K, 5%, 1/3 W	R33DC183J
R219, 220	Dep. Carbon, 15K, 5%, 1/3 W	R33DC153J
R221	Composition, 10M	RC20BF106K
R222, 223,		
224, 225	Dep. Carbon, 22K, 5%, 1/8 W	R12DC223J
R226, 227,		
228, 229,		
230	Dep. Carbon, 1M, 5%, 1/8 W	R12DC105J

MISCELLANEOUS

Symbol	Description	Part No.
CR100, 101,		
102, 103	Diode, Type 1112	V-1112
L100	Coil, Low Pass	L50210-30
L101	Coil, 5.25 M.H., 5%	L50334-1
L102, 103	Coil, 20 M.H., 5%	L50334-2
Z100	Transformer, 19Kc	ZZ50210-34
Z101	Coil, 38Kc	ZZ50210-33

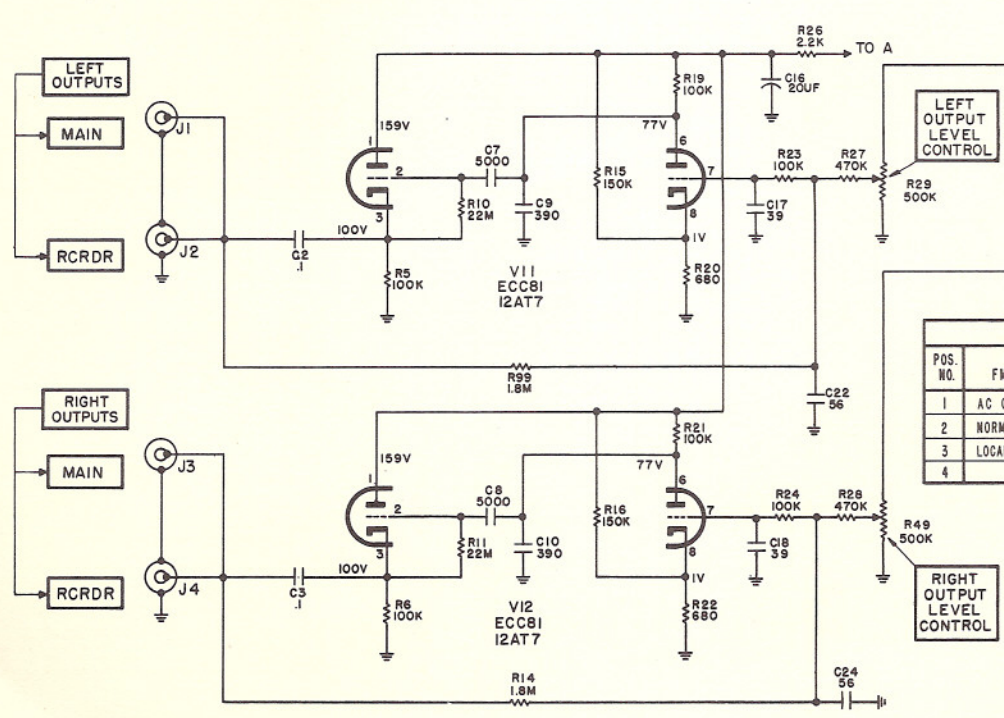
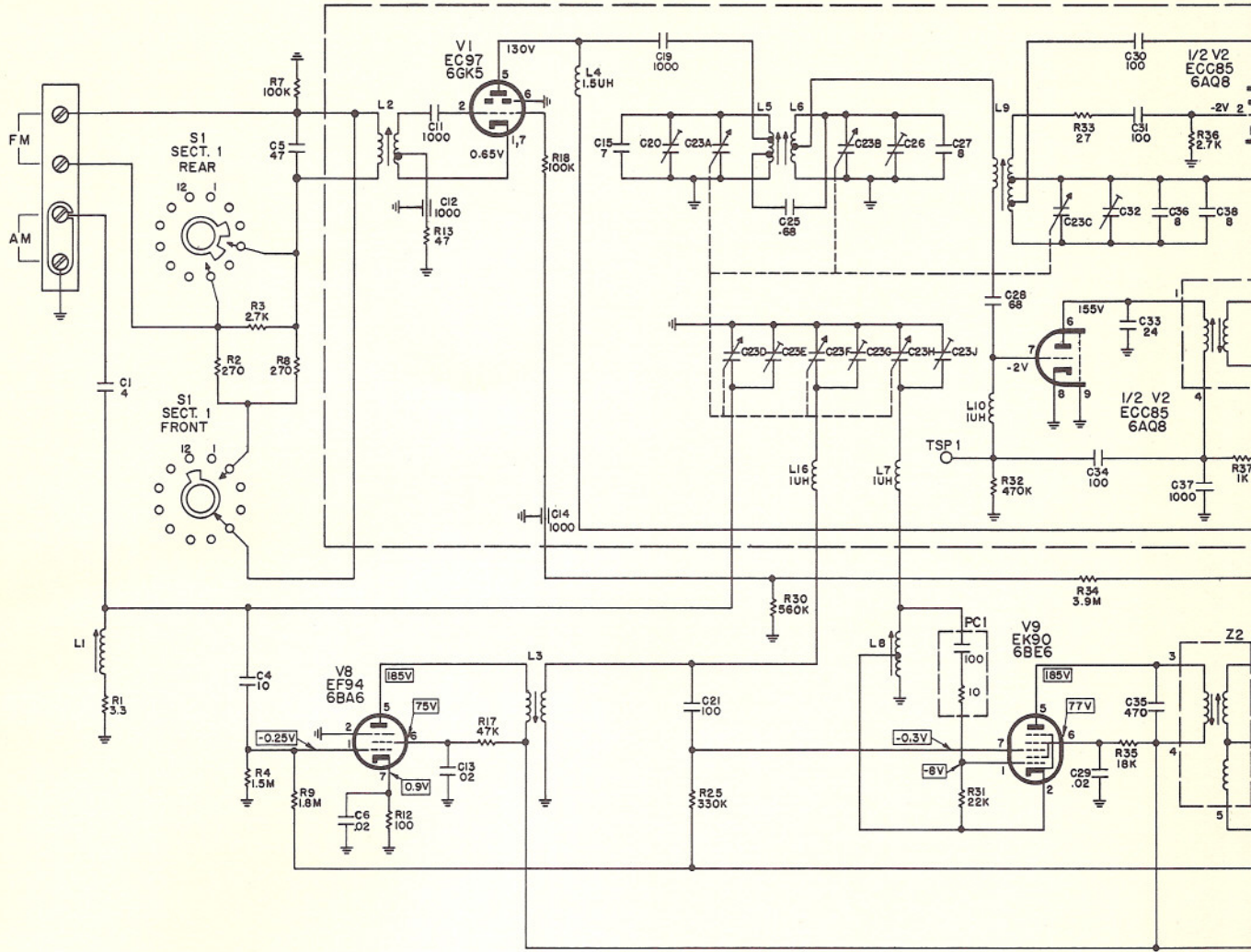

SWITCH POSITIONS				
POS. NO.	S1 FM ANTENNA SW.	S2 AM BANDWIDTH SW.	S3 SELECTOR SWITCH	S4 MUTING
1	AC OFF	SHARP	AM (MONO)	OFF
2	NORMAL (AC ON)	NORMAL	FM (MONO)	ON
3	LOCAL (AC ON)	WIDE	FM AUTOMATIC	
4			FM STEREO	

* ALL SWITCHES ARE SHOWN IN THE NUMBER 1 POSITION.

VOLTAGE MEASUREMENTS:
 A - READINGS NOT MARKED:
 1 - SELECTOR SWITCH POSITION: FM
 2 - MUTING CONTROL OFF AND NO SIGNAL AT ANTENNA TERMINALS.
 B - (FM) - SAME AS NOTE A, BUT WITH MUTING CONTROL IN MAXIMUM POSITION.
 C - (MPX) - SAME AS NOTE A, BUT WITH MPX SIGNAL AT ANTENNA TERMINALS.
 D - (AM) - SELECTOR SWITCH POSITION: AM WITH NO SIGNAL

SCHEMATIC DIAGRAM • TUNER

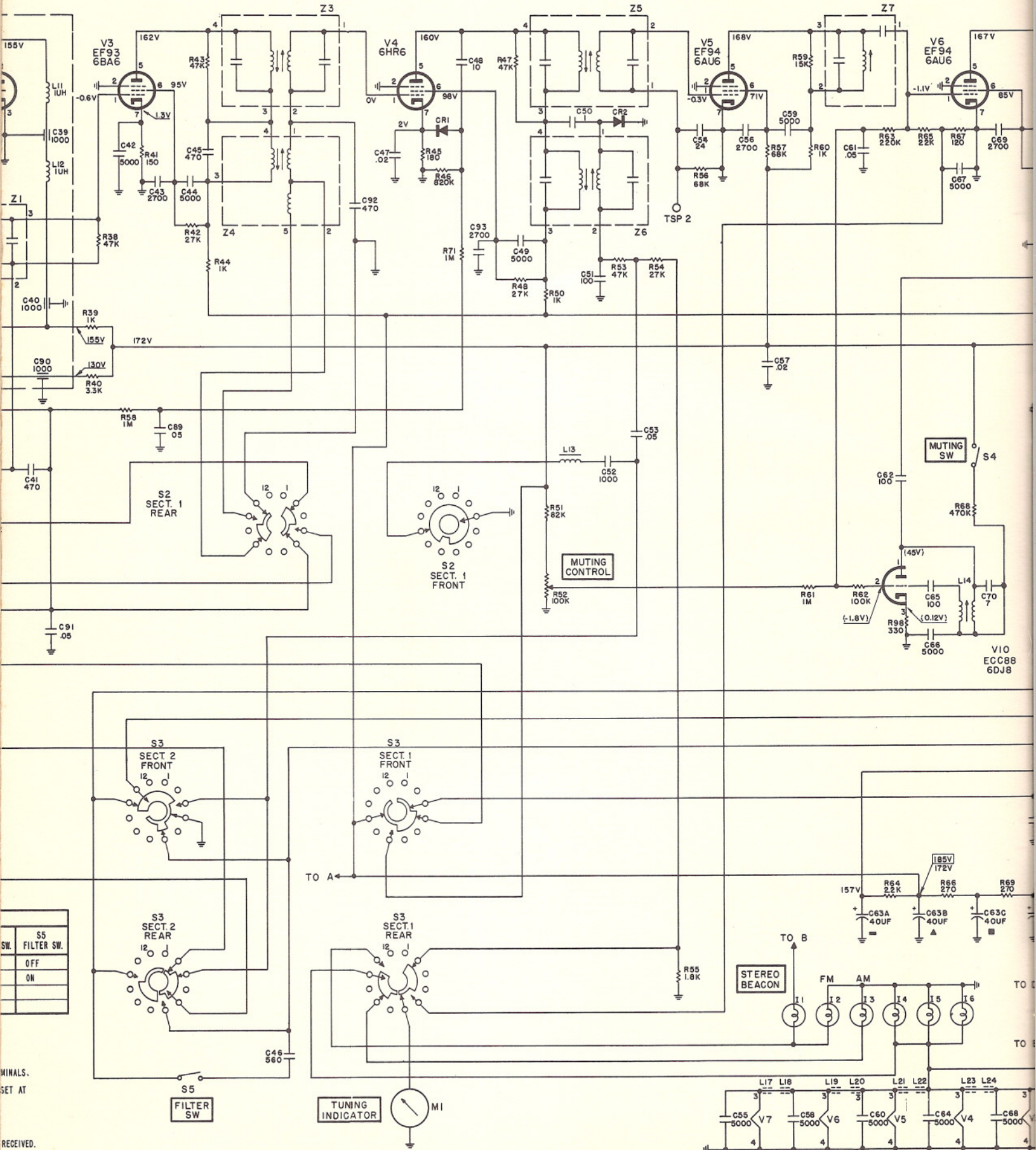

MINALS.
SET AT
RECEIVED.

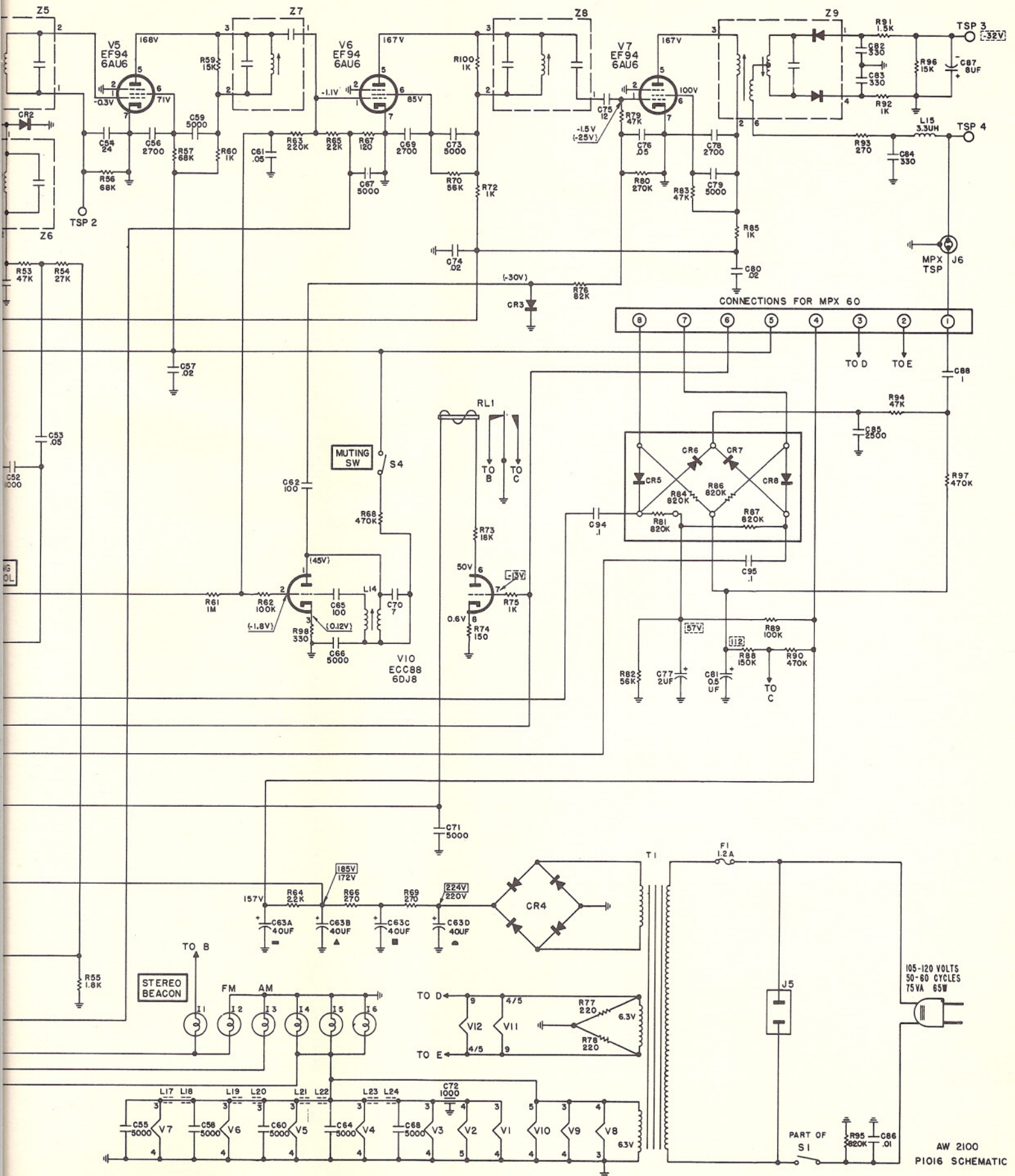

AW 2100
PI016 SCHEMATIC

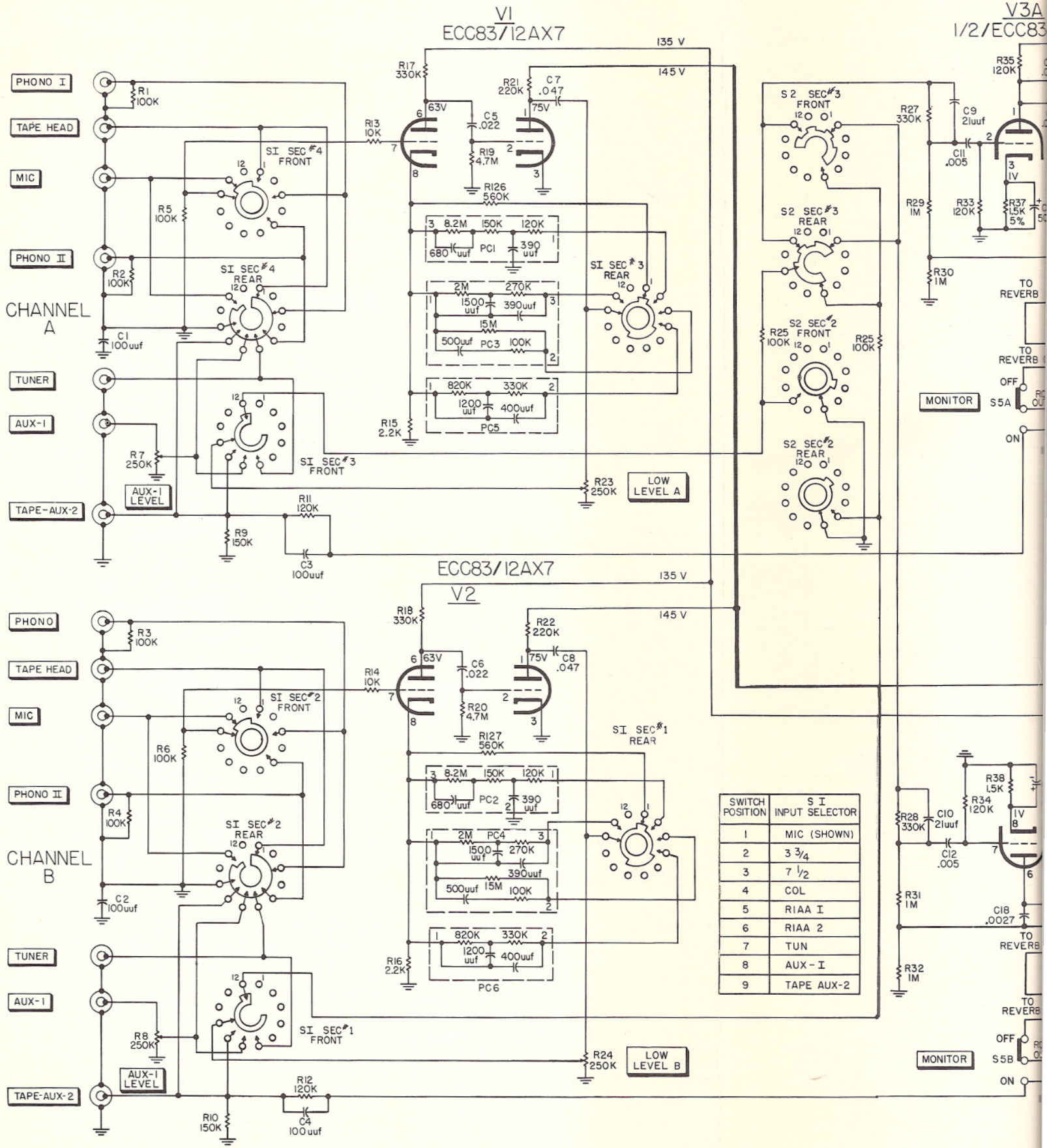

V1
ECC83/12AX7

V3A
1/2/ECC83

SWITCH POSITION	S I INPUT SELECTOR
1	MIC (SHOWN)
2	3 3/4
3	7 1/2
4	COL
5	RIAA I
6	RIAA 2
7	TUN
8	AUX - I
9	TAPE AUX-2

LOW LEVEL A

LOW LEVEL B

MONITOR

TO REVERB

TO REVERB

OFF

ON

TO REVERB

TO REVERB

OFF

ON

TO REVERB

TO REVERB

OFF

ON

V3A
1/2/ECC83/ 12AX7

V4
7247

1/2/ECC83

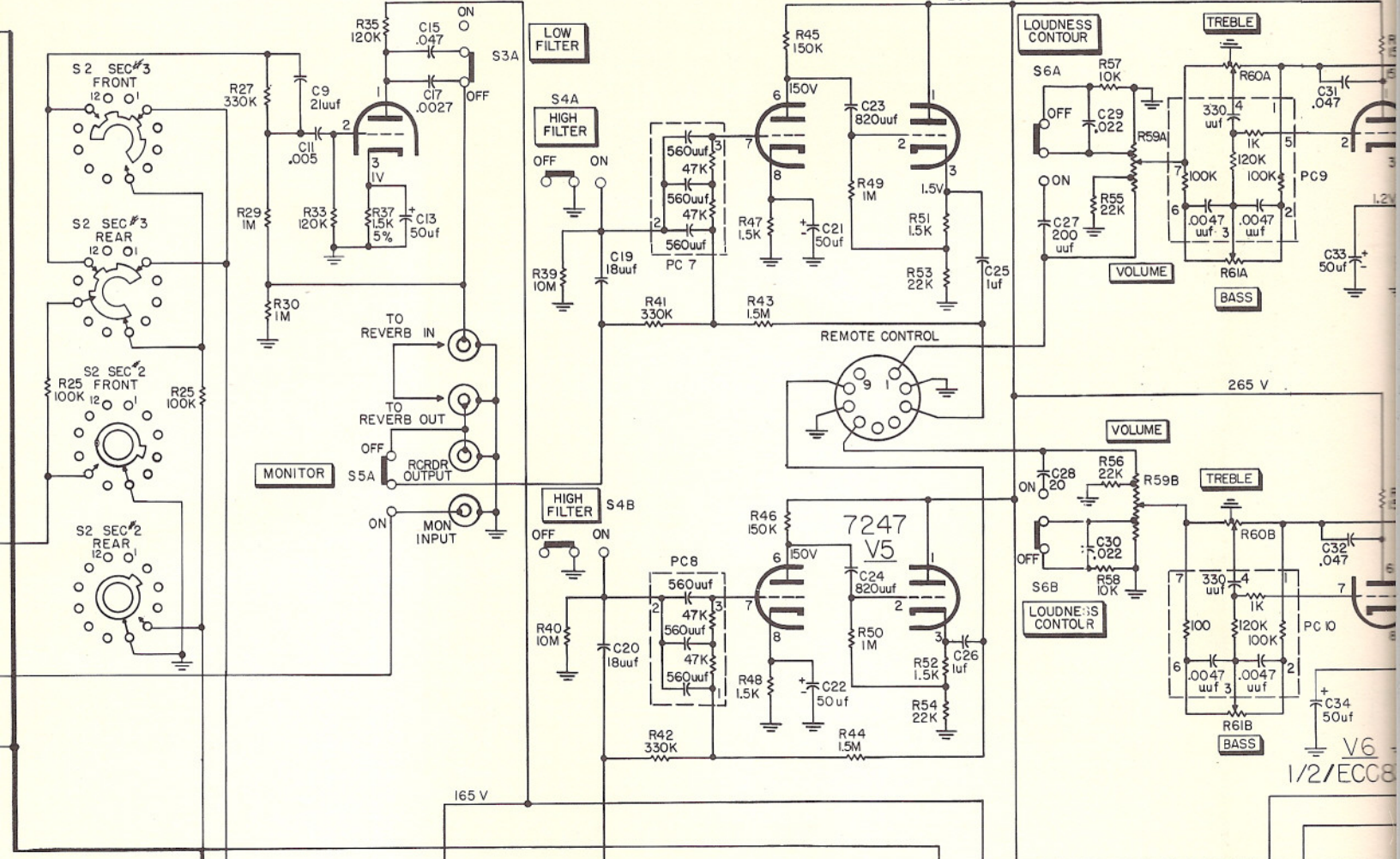

SWITCH POSITION	S 1 INPUT SELECTOR
1	MIC (SHOWN)
2	3 3/4
3	7 1/2
4	COL
5	RIAA I
6	RIAA 2
7	TUN
8	AUX - I
9	TAPE AUX-2

V3B
1/2
ECC83
12AX7

SWITCH POSITION	S15 CENTER SPEAKER
1	OFF (SHOWN)
2	1
3	2
4	3
5	MAX.

SWITCH POSITION	S2 MODE SELECTOR
1	MONO PHONO (SHOWN)
2	REVERSE
3	STEREO
4	A
5	B

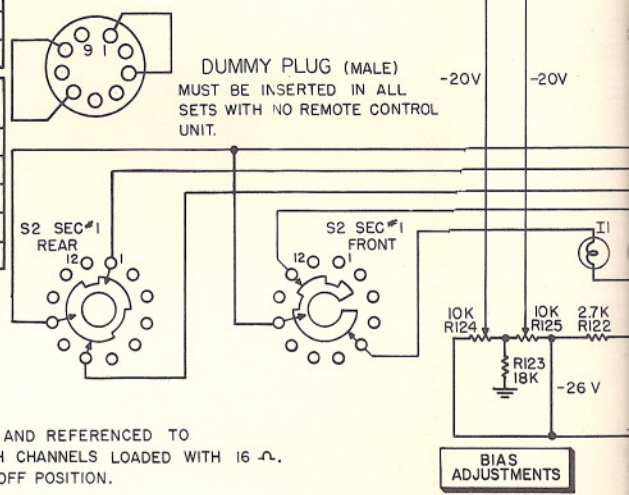
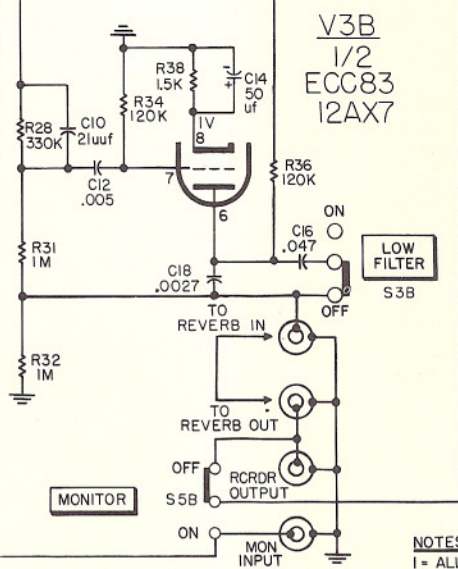

NOTES:
1= ALL VOLTAGES MEASURED WITH VTVM AND REFERENCED TO CHASSIS GROUND, - NO SIGNAL, BOTH CHANNELS LOADED WITH 16 Ω.
2= ALL SLIDE-SWITCHES SHOWN IN NORMAL OFF POSITION.

BIAS ADJUSTMENTS

SCHEMATIC DIAGRAM • CONTROL-AMPLIFIER

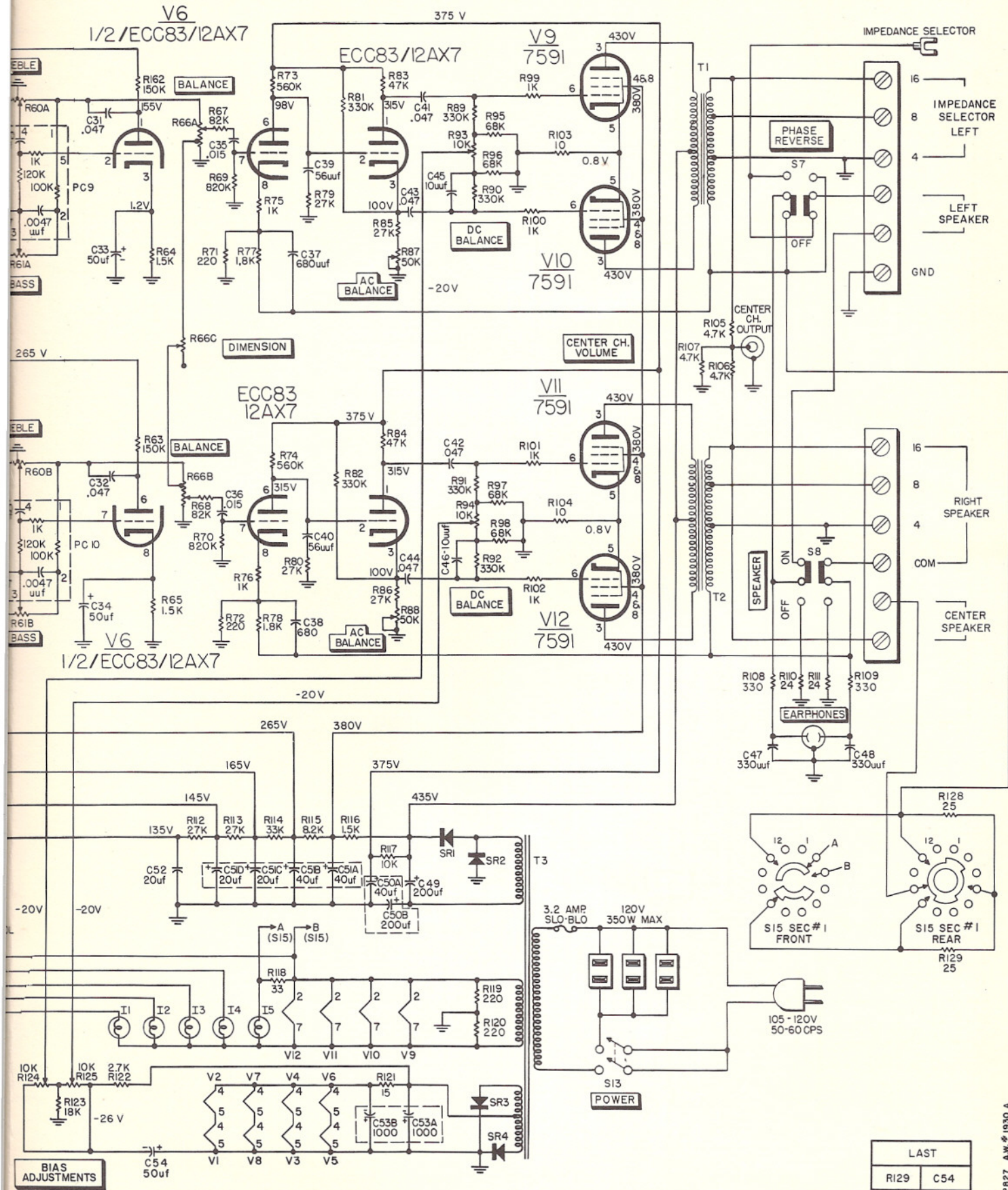

LAST	
R129	C54

PARTS DESCRIPTION LIST • CONTROL-AMPLIFIER

CAPACITORS

10% tolerance for all fixed capacitors, unless otherwise noted or marked GMV (guaranteed minimum value).

Symbol	Description	Part No.
C1, 2	Ceramic, 100uf, GMV, N1500, 1000V	C50070-5
C3, 4	Ceramic, 100uf, N1500, 1000V	C50070-6
C5, 6	Mylar, .022uf, 400V	C50197-28
C7, 8	Mylar, .047uf, 400V	C50197-30
C9, 10	Ceramic, 21uf, 5%, N750, 1000V	C50070-32
C11, 12	Ceramic, .005uf, 20%, 500V	C50089-1
C13, 14	Electrolytic, 50uf, 3V	C50283-1
C15, 16	Mylar, .047uf, 400V	C50197-30
C17, 18	Ceramic, .0027uf, 1000V	C50072-17
C19, 20	Ceramic, 18uf, N470, 1000V	C50070-13
C21, 22	Electrolytic, 50uf, 3V	C50283-1
C23, 24	Ceramic, 820uf, 1000V	C50072-7
C25, 26	Mylar, 1uf, 150V	C50197-78
C27, 28	Ceramic, 200uf, 1000V	C50072-22
C29, 30	Mylar, .022uf, 250V	C50197-49
C31, 32	Mylar, .047uf, 400V	C50197-30
C33, 34	Electrolytic, 50uf, 3V	C50283-1
C35, 36	Mylar, .015uf, 250V	C50197-49
C37, 38	Ceramic, 680uf, 1000V	C50072-2
C39, 40	Ceramic, 56uf, N1500, 1000V	C50070-22
C41, 42, 43, 44	Mylar, .047uf, 400V	C50197-30
C45, 46	Ceramic, 10uf, NPO, 1000V	C50070-11
C47, 48	Ceramic, 330uf, 1000V	C50072-1
C49	Electrolytic, 200uf, 250V	C50180-20
C50	Electrolytic, 2 section A — 40uf, 500V B — 20 uf, 250V	C50180-19
C51	Electrolytic, 4 section A — 40uf, 450V B — 40uf, 400V C — 20uf, 300V D — 20uf, 300V	C50180-12
C52	Electrolytic, 20uf, 250V	C746-145
C53	Electrolytic, 2 section, com. Pos. A — 1000uf, 35V B — 1000uf, 35V	C50180-37
C54	Electrolytic, 50uf, 70V	C50283-2

RESISTORS AND POTENTIOMETERS

In ohms, 10% tolerance, 1/2 watt, unless otherwise noted. K=Kilohm, M=Megohm.

Symbol	Description	Part No.
R1, 2, 3, 4, 5, 6	Dep. Carbon, 100K, 5%, 1/3 W	R33DC104J
R7, 8	Potentiometer, 250K, aux-1 level	R50103-1
R9, 10	Dep. Carbon, 150K, 5%, 1/3 W	R33DC154J
R11, 12	Dep. Carbon, 120K, 5%, 1/3 W	R33DC124J
R13, 14	Dep. Carbon, 10K, 5%, 1/3 W	R33DC103J
R15, 16	Glass, 2.2K, 5%, 1W	R30G222J
R17, 18	Glass, 330K, 5%, 1W	R30G334J
R19, 20	Dep. Carbon, 4.7M, 5%, 1/3 W	R33DC475J
R21, 22	Dep. Carbon, 220K, 5%, 1/3 W	R33DC224J
R23, 24	Potentiometer, 250K, dual, low level	R50160-99
R25, 26	Dep. Carbon, 100K, 5%, 1/3 W	R33DC104J
R27, 28	Dep. Carbon, 330K, 5%, 1/3 W	R33DC334J
R29, 30, 31, 32	Dep. Carbon, 1M, 5%, 1/3 W	R33DC475J
R33, 34, 35, 36	Dep. Carbon, 120K, 5%, 1/3 W	R33DC124J
R37, 38	Dep. Carbon, 1.5K, 5%, 1/3 W	R33DC152J
R39, 40	Composition, 10M	RC20BF106K
R41, 42	Dep. Carbon, 330K, 5%, 1/3 W	R33DC334J
R43, 44	Dep. Carbon, 1.5M, 5%, 1/3 W	R33DC155J
R45, 46	Dep. Carbon, 150K, 5%, 1/3 W	R33DC154J
R47, 48	Dep. Carbon, 1.5K, 5%, 1/3 W	R33DC152J
R49, 50	Dep. Carbon, 1M, 5%, 1/3 W	R33DC105J
R51, 52	Dep. Carbon, 1.5K, 5%, 1/3 W	R33DC152J
R53, 54	Composition, 22K, 1W	RC30BF223K
R55, 56	Dep. Carbon, 22K, 5%, 1/3 W	R33DC223J
R57, 58	Dep. Carbon, 10K, 5%, 1/3 W	R33DC103J
R59	Potentiometer, dual, 100K, volume	R50160-84
R60	Potentiometer, dual, 500K, treble	R50169-85
R61	Potentiometer, dual, 1M, bass	R50160-87
R62, 63	Dep. Carbon, 150K, 5%, 1/3 W	R33DC154J
R64, 65	Dep. Carbon, 1.5K, 5%, 1/3 W	R33DC152J

R66	Potentiometer, dual, 300K, bal., 1M, dim.	R50160-100
R67, 68	Composition, 82K	RC20BF823K
R69, 70	Composition, 820K	RC20BF824K
R71, 72	Composition, 220	RC20BF221K
R73, 74	Composition, 560K, 5%	RC20BF564J
R75, 76	Dep. Carbon, 1K, 5%, 1/3 W	R33DC102J
R77, 78	Composition, 1.8K, 5%	RC20BF182J
R79, 80	Composition, 27K	RC20BF273K
R81, 82	Dep. Carbon, 330K, 5%, 1/3 W	R33DC334J
R83, 84	Dep. Carbon, 47K, 5%, 1/3 W	R33DC473J
R85, 86	Composition, 27K	RC20BF273K
R87, 88	Potentiometer, 50K, AC balance	R50103-3
R89, 90, 91, 92	Dep. Carbon, 330K, 5%, 1/3 W	R33DC334J
R93, 94	Potentiometer, 10K, DC balance	R50103-5
R95, 96, 97, 98	Composition, 68K, 5%	RC20BF683J
R99, 100, 101, 102	Dep. Carbon, 1K, 5%, 1/3 W	R33DC102J
R103, 104	Wirewound, 10, 5W	R779-103
R105, 106, 107	Composition, 4.7K	RC20BF472K
R108, 109	Composition, 330, 1W	RC30BF222K
R110, 111	Glass, 24, 7W	RP7W240K
R112, 113	Composition, 27K	RC20BF273K
R114	Composition, 33K, 1W	RC20BF333K
R115	Composition, 8.2K, 1W	RC30BF822K
R116	Glass, 1.5K, 4W	RP4W152K
R117	Composition, 10K, 1W	RC30BF103K
R118	Composition, 33	RC20BF330K
R119, 120	Composition, 220	RC20BF221K
R121	Wirewound, 15, 5W	R719-106
R122	Composition, 2.7K	RC20BF272K
R123	Composition, 18K	RC20BF183K
R124, 125	Potentiometer, 10K, bias	R50103-5
R126, 127	Composition, 560K, 5%	RC20BF564J
R128, 129	Wirewound, 25, 5W	R688-117

MISCELLANEOUS

Symbol	Description	Part No.
F1	Fuse, 3.2 Amp., Slo-Blo	F3319
I1, 2, 3, 4, 5	Bulb, #47	I50009-1
PC1, 2	Printed Circuit, 3 3/4" Tape Equalization	PC50187-7
PC3, 4	Printed Circuit, RIAA, Tape 7 1/2"	PC50187-3
PC5, 6	Printed Circuit, Col. Equalization	PC50187-6
PC7, 8	Printed Circuit, High Filter	PC50187-5
PC9, 10	Printed Circuit, Tone Control	PC657-140
S1	Switch, Input Selector	S841-125
S2	Switch, Mode Selector	S841-136
S3, 4, 5, 6, 7, 8	Switch, Slide	S50200-5
S13	Switch, Power	Part of R59
S15	Switch, Center Speaker	S827-129
SR1, 2	Silicon Diode, B+	SR806-126
SR3, 4	Silicon Diode, Filament & Bias	SR851-122
T1	Transformer, Output CH A	T827-116
T2	Transformer, Output CH B	T827-116
T3	Transformer, Power	T827-115
—	Dress Panel	AS 1003-108
—	Tube Shield, 9 pin	E3287
—	Knob	E50325-1
—	Knob, Dual, Bottom	E50221
—	Knob, Dual, Top	E50323
—	Knob, Dummy Dual	E50324
—	Plastic Foot	H50277
—	Jewel, Red	I50162-1
—	Jewel, Yellow	I50162-2
—	Jewel, Green	I50162-4
—	Jack, Earphone	J846-120-1
—	Fuse Holder	X50329
—	Model 1200, Ampex Tape Recorder	A50381
—	Automatic Shut-Off Assembly	A5988-115
—	Microphone Stand	A776-110
—	45 RPM Spindle for Miracord Model 10	A50412-7
—	Phono Cartridge, Pickering U38-AT	G50286-1
—	Microphone	Q776-109
—	Automatic Turntable, Miracord Model 10	RC50428
—	Automatic Shut-Off Switch	S50358-4

SCHEMATIC DIAGRAM • SPEAKER SYSTEMS

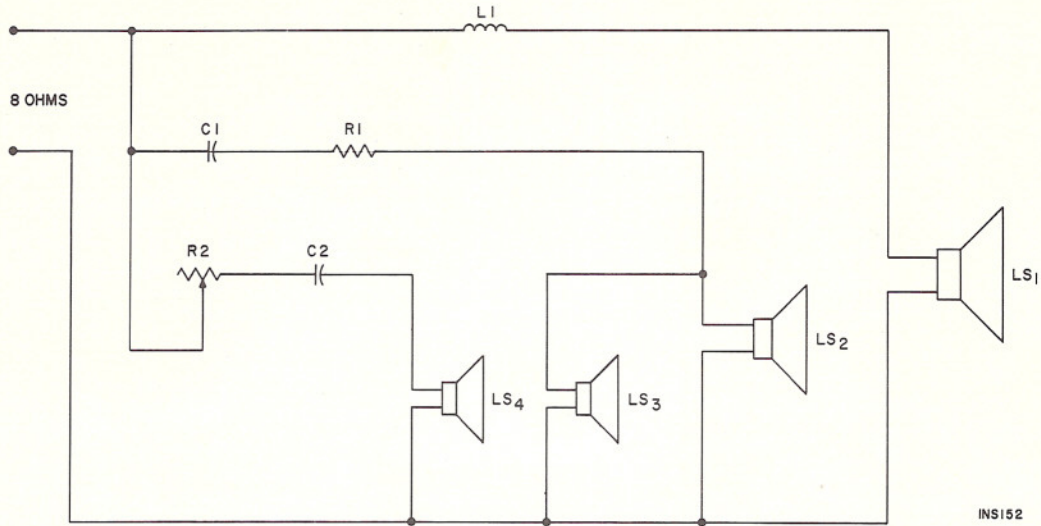

PARTS DESCRIPTION LIST • SPEAKER SYSTEMS

Symbol	Description	Part No.
LS1	Speaker, 12" Woofer, 8 ohms	W-102
LS2, 3	Speaker, 5" Midrange, 8 ohms	M-114
LS4	Speaker, 3 1/2" Tweeter, 8 ohms	T-109
C1	Capacitor, 2uf	C-308
C2	Capacitor, 1uf	C-309
L1	Coil, Crossover	L-207
R1	Resistor, 33 ohms	R-410
R2	Potentiometer	P-500

SCHEMATIC DIAGRAM • AUTOMATIC SHUT-OFF ASSEMBLY

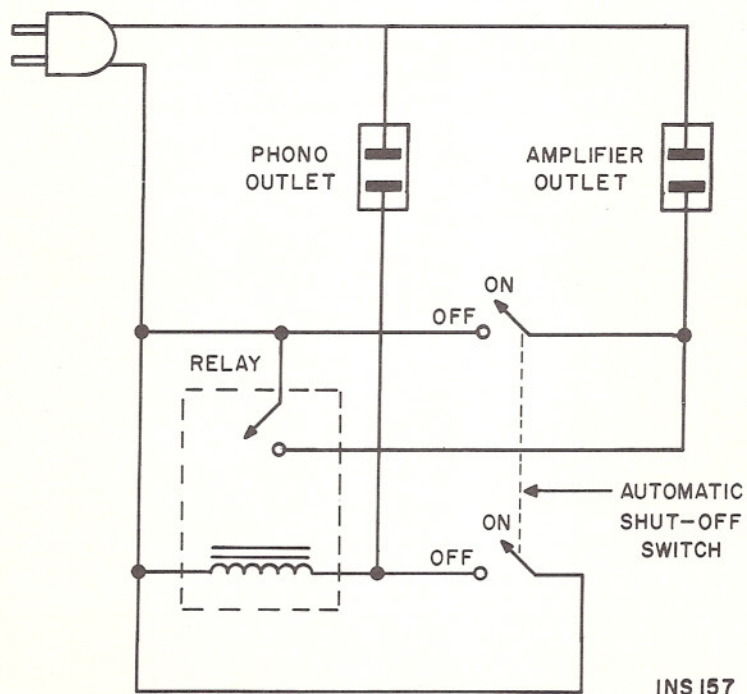

TUBE LAYOUT • TUNER

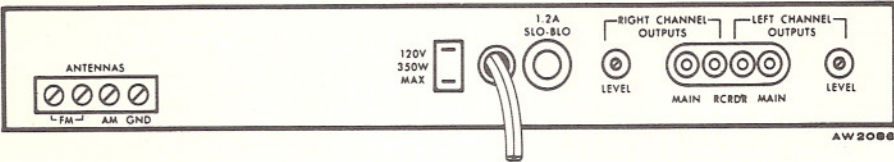
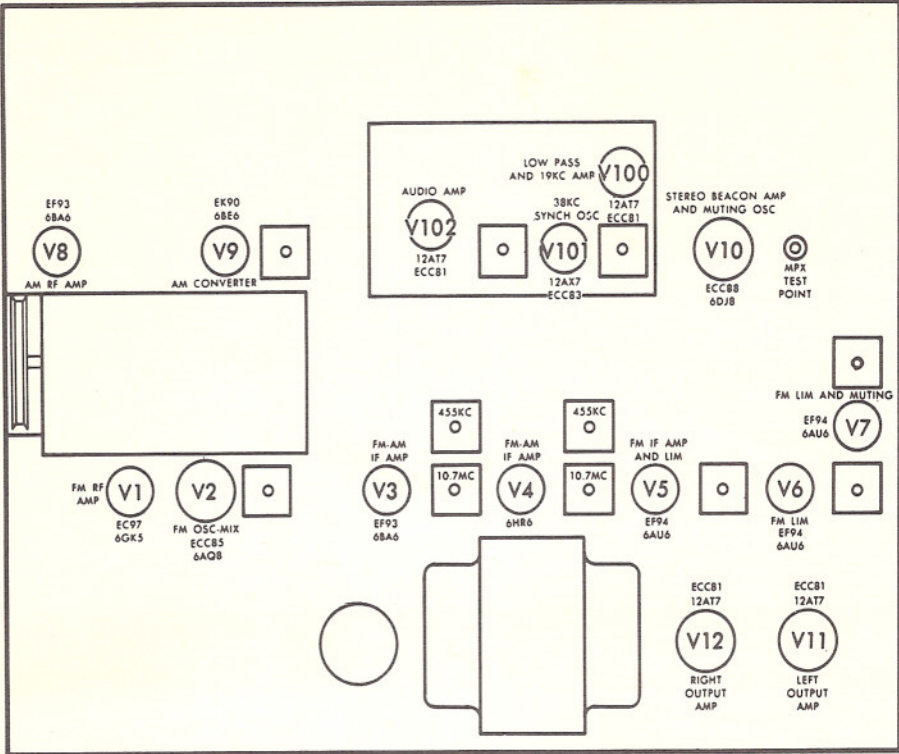

TUBE LAYOUT • CONTROL-AMPLIFIER

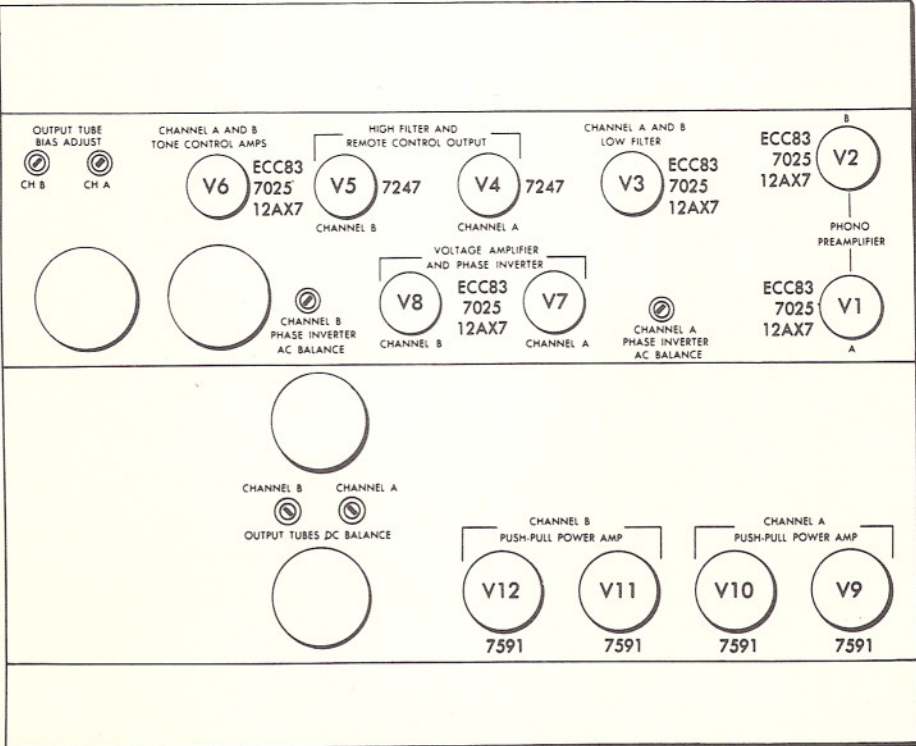

TUBE LAYOUT • TAPE RECORDER

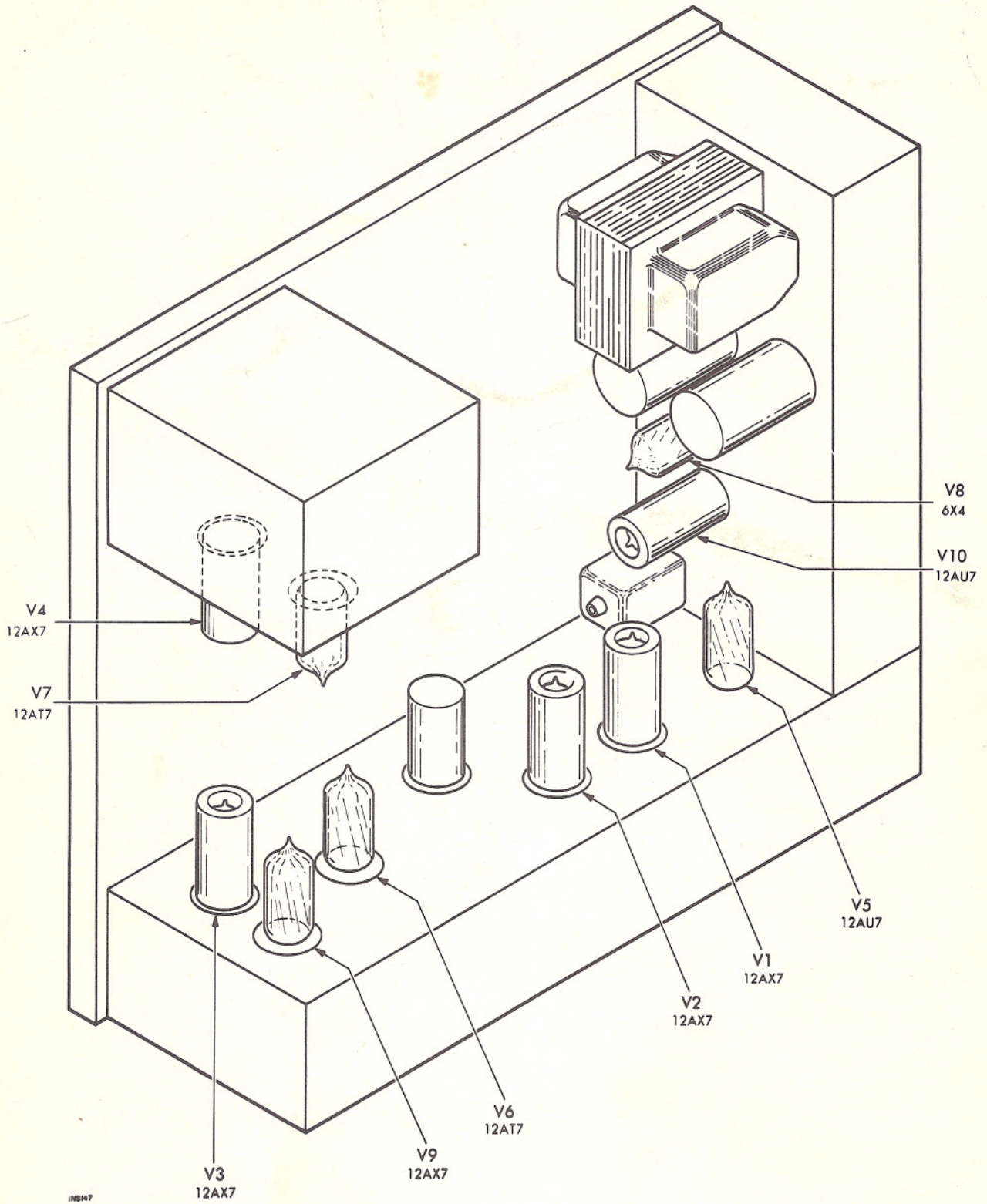

1HS147



FISHER RADIO CORPORATION • NEW YORK

N 1003-103

© 1963 FISHER RADIO CORPORATION

PRINTED IN U. S. A.

651-W12C-43