

FISHER MODEL SA-300

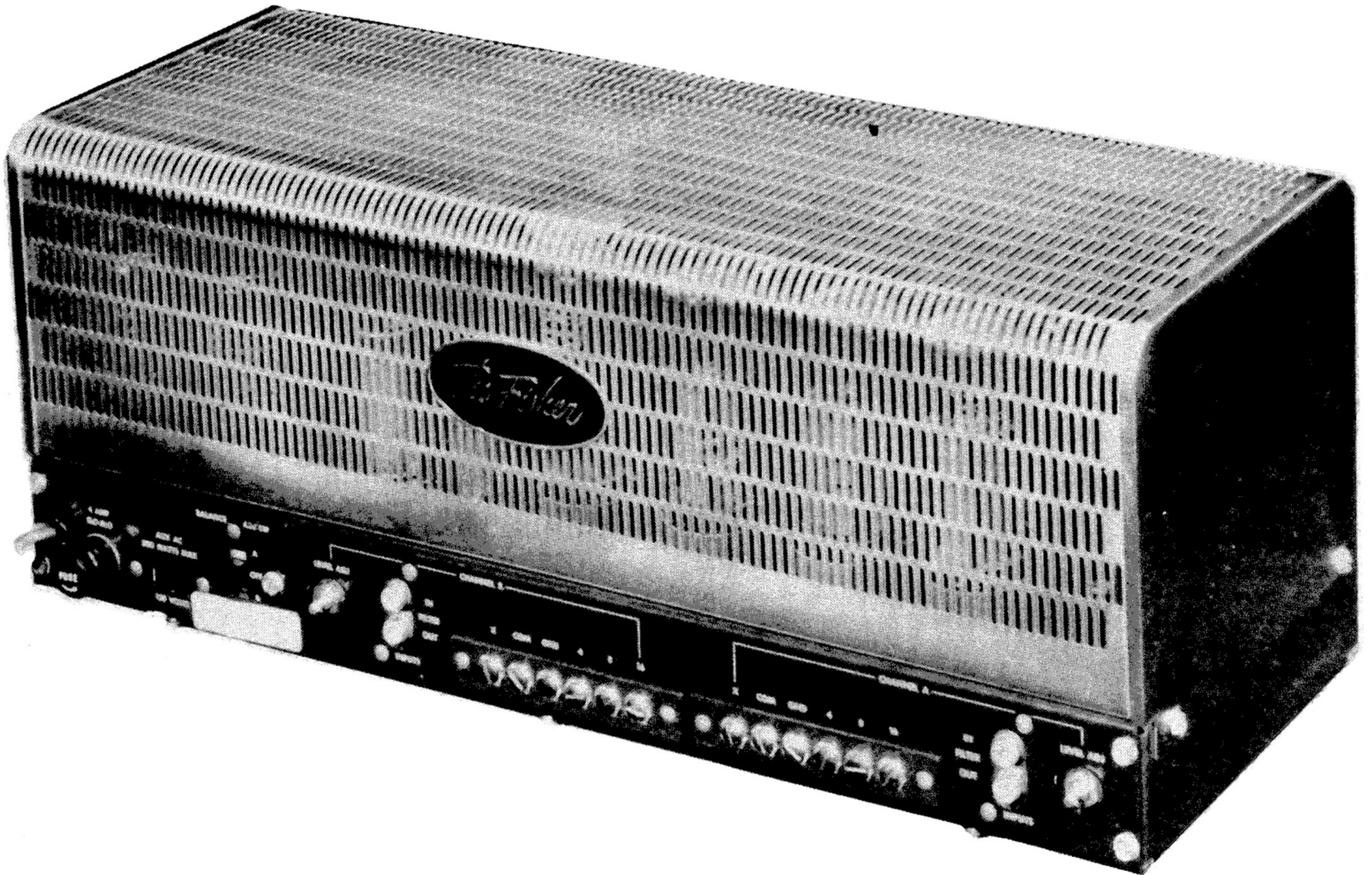

TRADE NAME	Fisher Model SA-300		
MANUFACTURER	Fisher Radio Corp., 21-21 44th Drive, Long Island City 1, N. Y.		
TYPE SET	AC Operated 10 Tube Stereo Amplifier		
POWER SUPPLY	105-120 Volts AC, 50-60 Cycles	RATING	230 Watts, 2.2 Amp. @ 117 Volts AC

ADJUSTMENTS

HUM & DC BALANCE

1. Remove all connections to amplifier except power cord.
2. Turn Input Level Controls (R1, R2) fully counterclockwise and Balance Switch (M3) off.
3. Connect an AC VTVM between Channel A output terminals 16 and GND.
4. Adjust Channel A DC Balance (R3) and Hum (R8) for minimum meter deflection (should not exceed .2MV).
5. Connect an AC VTVM between Channel B output terminals 16 and GND.
6. Adjust Channel B DC Balance (R6) and Hum (R9) for minimum meter deflection (should not exceed .2MV).

PHASE INVERTER BALANCE

1. Remove all connections to amplifier except power cord.
2. Turn Input Level controls (R1, R2) fully counterclockwise and Balance Switch (M3) to Channel A.
3. Connect an AC VTVM between Channel A output terminals 16 and GND.
4. Adjust AC Balance (R4) for minimum meter deflection.
5. Repeat procedure for Channel B.
6. Turn Balance Switch (M3) to Off.

BIAS

1. Connect a DC VTVM from point **A** to chassis.
2. Adjust power source for 117 Volts AC.
3. Turn Balance Switch (M3) off.
4. Adjust Bias (R7) for 7.8 Volts.
5. Connect meter to point **B**. Meter should indicate between 7.3V and 8.3V. If necessary, readjust R7.

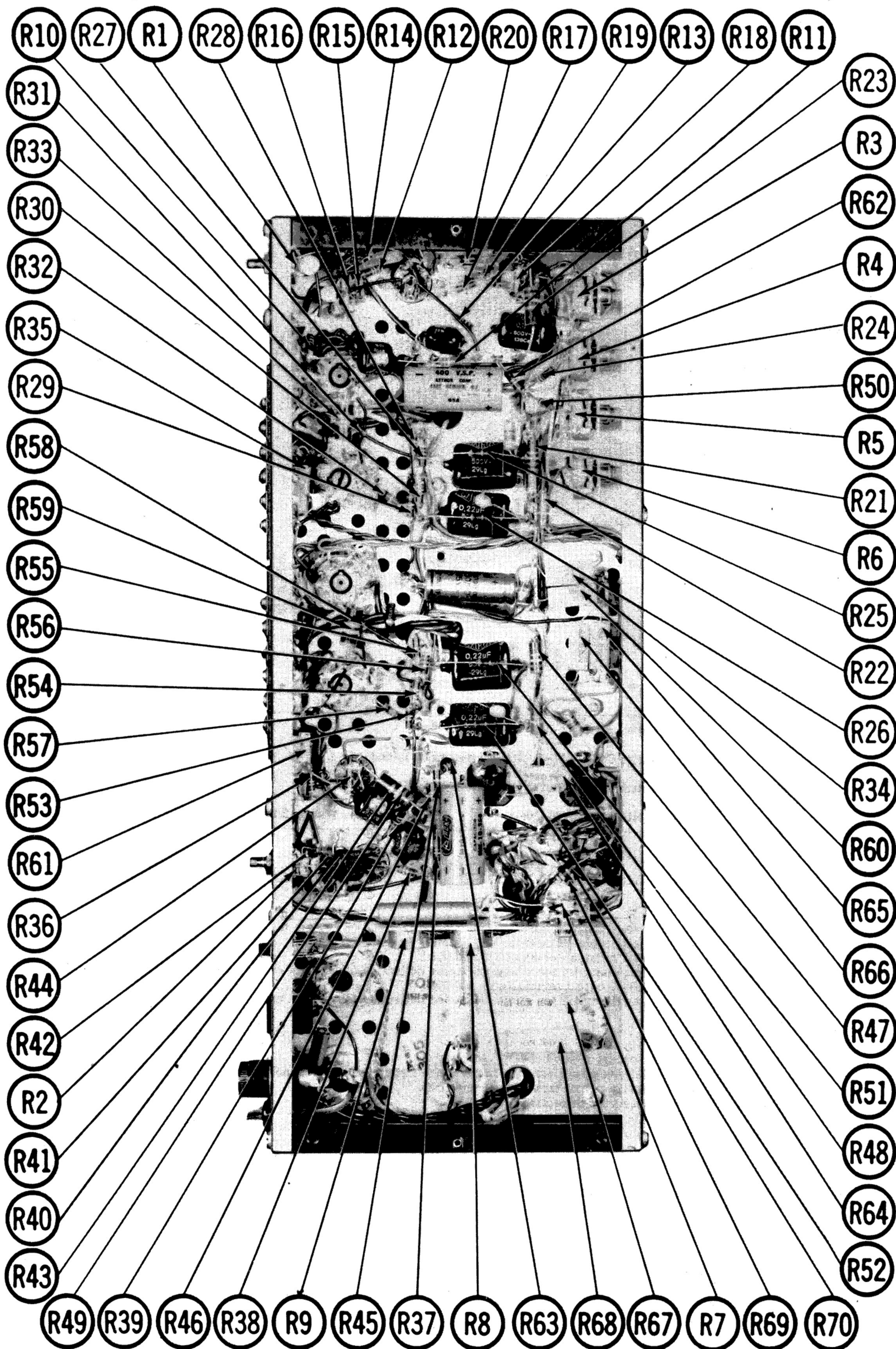

CHASSIS BOTTOM VIEW-RESISTOR IDENTIFICATION

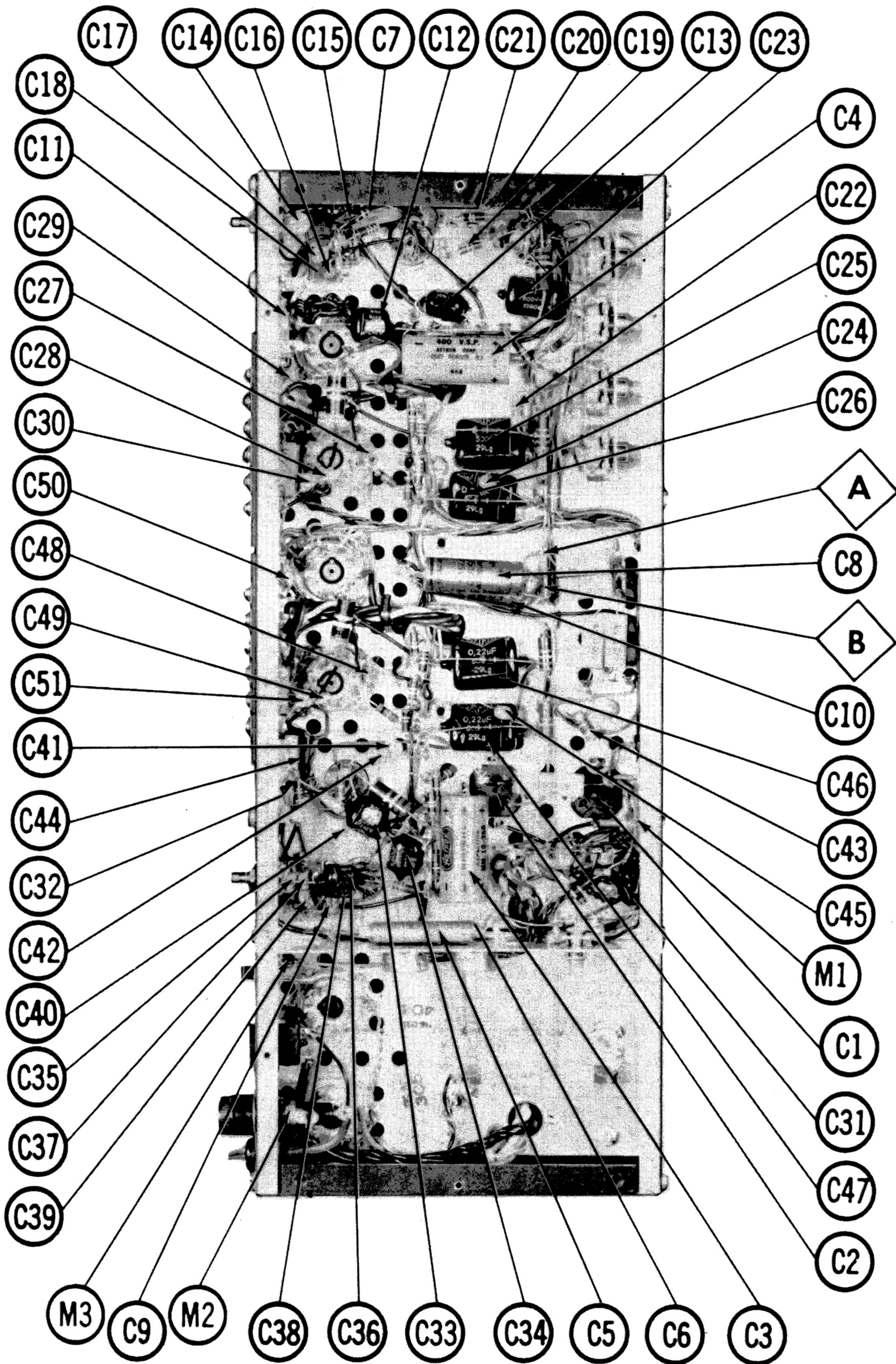

CHASSIS BOTTOM VIEW - CAPACITOR & MISC. IDENT.

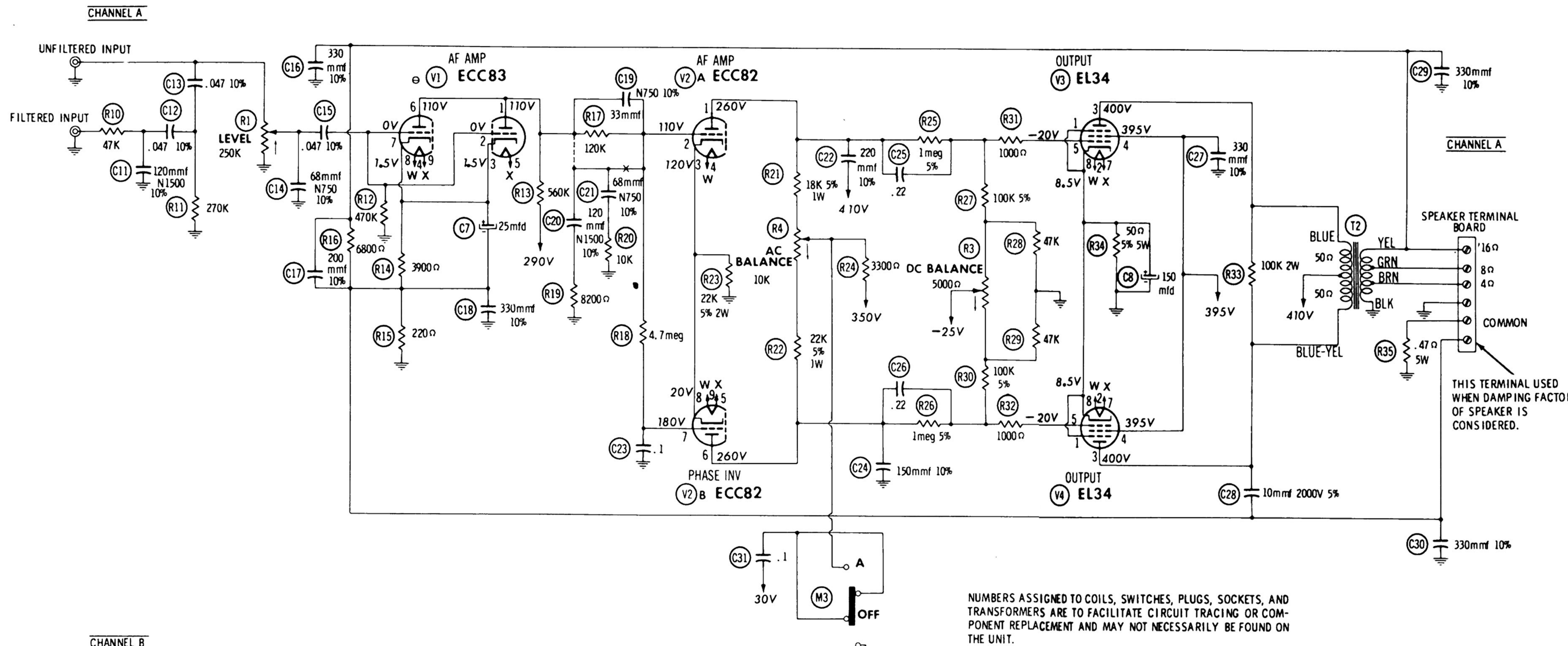

1. DC voltage measurements taken with vacuum tube voltmeter; AC voltages measured at 1000 ohms per volt.
2. Socket connections are shown as bottom views.
3. Measured values are from socket pin to common negative.
4. Line voltage maintained at 117 volts for voltage readings.
5. Nominal tolerance of component values makes possible a variation of ±15% in voltage and resistance readings.
6. All controls at minimum, proper output load connected.

RESISTANCE READINGS

ITEM	TUBE	Pin 1	Pin 2	Pin 3	Pin 4	Pin 5	Pin 6	Pin 7	Pin 8	Pin 9
V1	ECC83	† 685K	470K	4100Ω	125Ω	125Ω	† 685K	470K	4100Ω	125Ω
V2	ECC82	† 33K	† 800K	22K	125Ω	125Ω	† 35K	15.4meg	22K	125Ω
V3	EL34	50Ω	125Ω	180Ω	† 630Ω	135K	NC	125Ω	50Ω	
V4	EL34	50Ω	125Ω	180Ω	† 630Ω	135K	NC	125Ω	50Ω	
V5	ECC83	† 680K	470K	4100Ω	125Ω	125Ω	† 680K	470K	4100Ω	125Ω
V6	ECC82	† 33K	† 800K	22K	125Ω	125Ω	† 35K	15.4meg	22K	125Ω
V7	EL34	50Ω	125Ω	180Ω	† 630Ω	135K	NC	125Ω	50Ω	
V8	EL34	50Ω	125Ω	180Ω	† 630Ω	135K	NC	125Ω	50Ω	
V9	GZ34	NC	†	NC	14Ω	NC	14Ω	NC	†	
V10	GZ34	NC	†	NC	14Ω	NC	14Ω	NC	†	

† THIS READING WILL VARY DEPENDING UPON THE CONDITION OF THE ELECTROLYTIC IN THE CIRCUIT.
 † MEASURED FROM PIN 8 OF V10.
 NC NO CONNECTION

NUMBERS ASSIGNED TO COILS, SWITCHES, PLUGS, SOCKETS, AND TRANSFORMERS ARE TO FACILITATE CIRCUIT TRACING OR COMPONENT REPLACEMENT AND MAY NOT NECESSARILY BE FOUND ON THE UNIT.

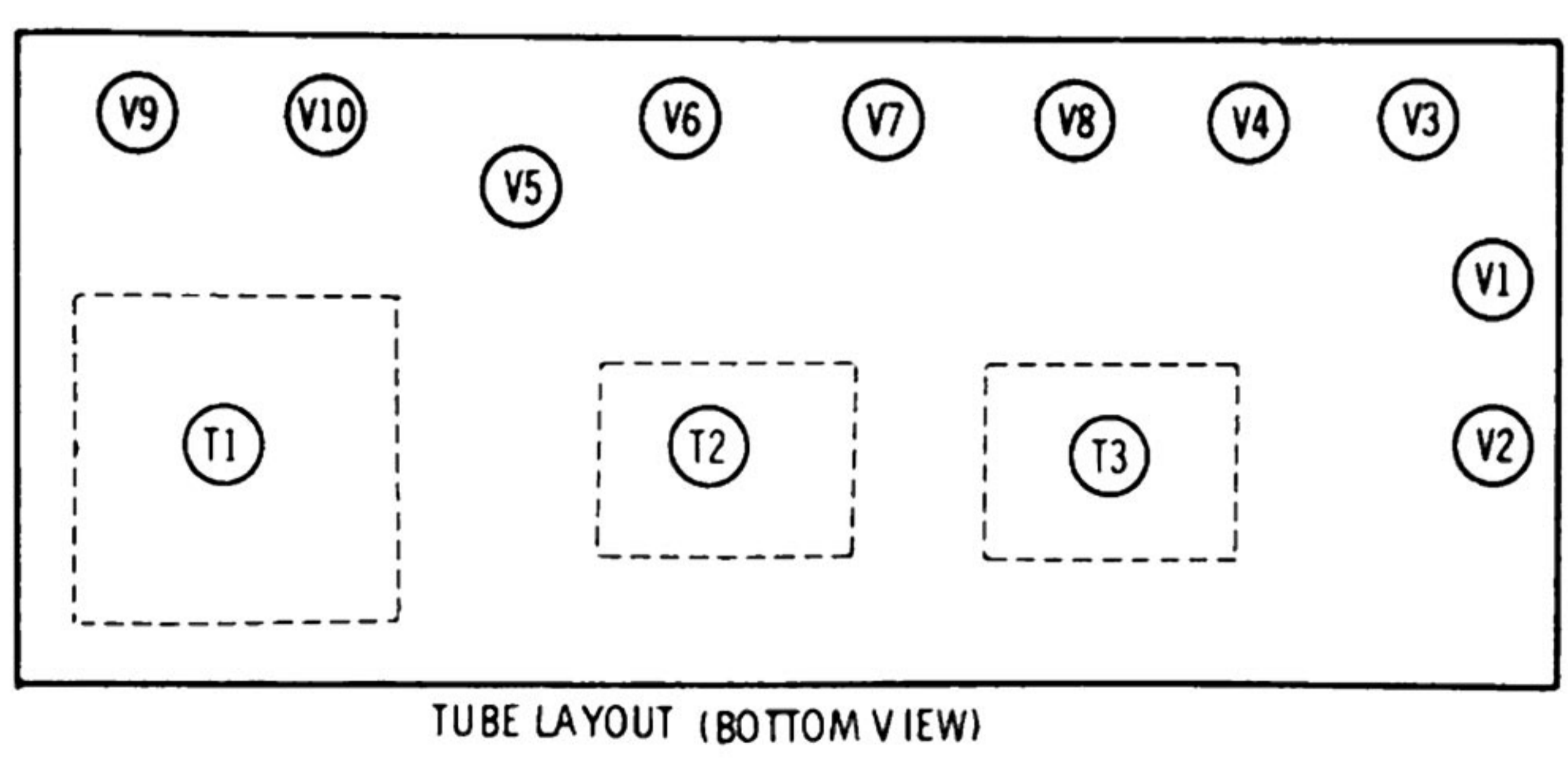
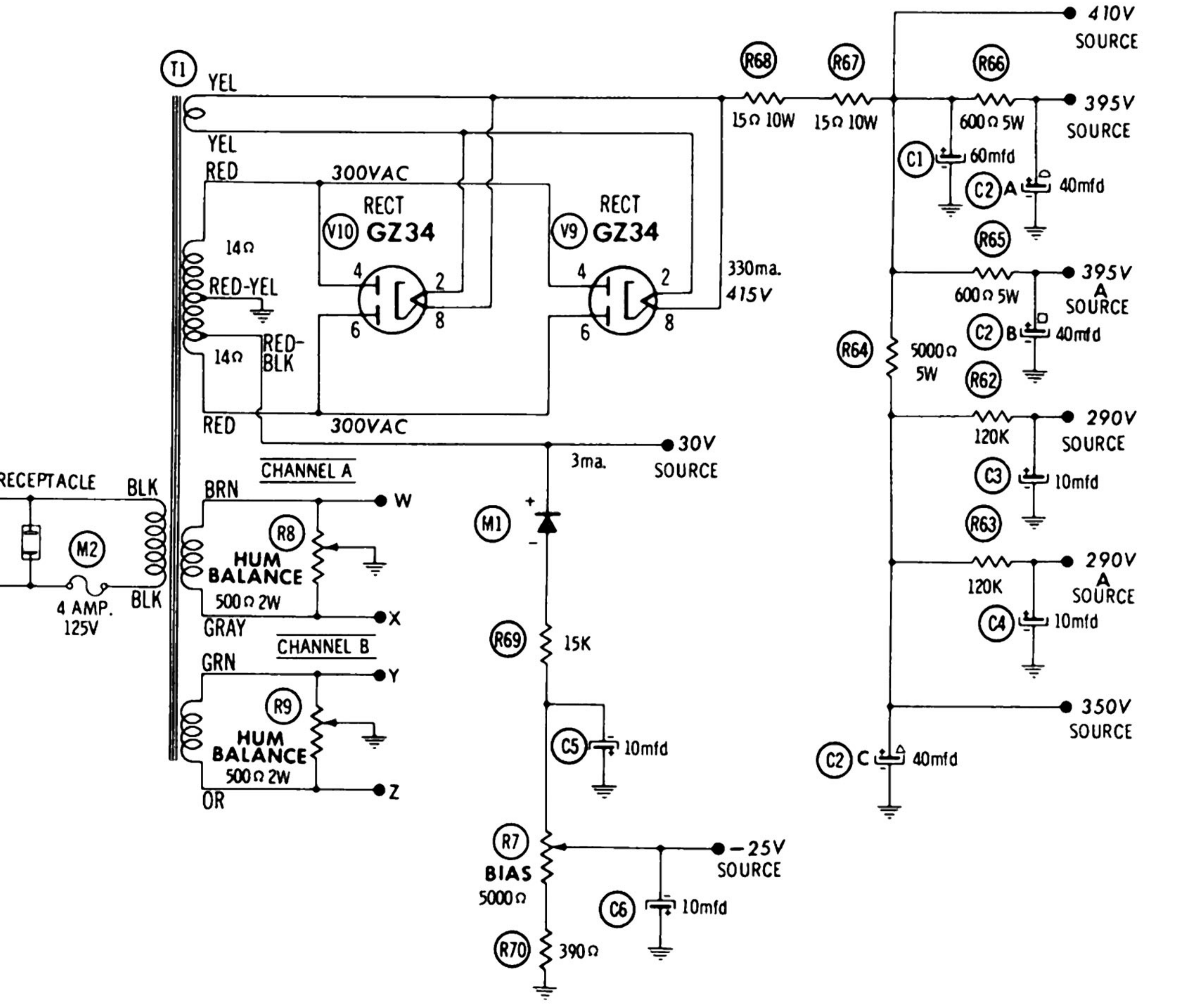
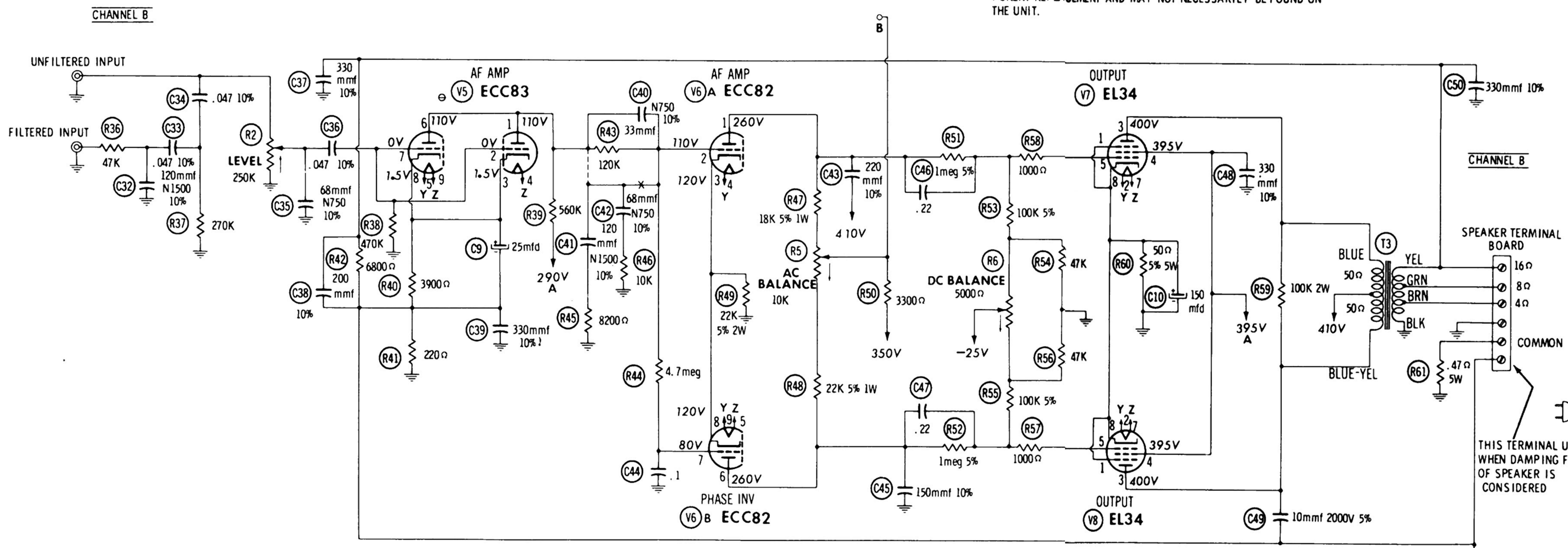

SEE PARTS LIST FOR ALTERNATE VALUE OR APPLICATION
 DC COIL RESISTANCE VALUES UNDER ONE OHM NOT SHOWN ON SCHEMATIC DIAGRAM
 ARROWS ON CONTROLS INDICATE CLOCKWISE ROTATION (CONTROL VIEWED FROM SHAFT END)

PARTS LIST AND DESCRIPTIONS

TUBES

CBS			GENERAL ELECTRIC			RAYTHEON			SYLVANIA		
ITEM No.	USE	TYPE	ITEM No.	USE	TYPE	ITEM No.	USE	TYPE	ITEM No.	USE	TYPE
V1	Channel A AF Amp.	ECC83 (12AX7, 7025)*	V6	Channel B AF Amp. - Phase Inverter	ECC82 (12AU7A) *						
V2	Channel A AF Amp. - Phase Inverter	ECC82 (12AU7A) *	V7	Channel B Output	EL34 (6CA7) *						
V3	Channel A Output	EL34 (6CA7) *	V8	Channel B Output	EL34 (6CA7) *						
V4	Channel A Output	EL34 (6CA7) *	V9	Rectifier	GZ34 (5AR4) *						
V5	Channel B AF Amp.	ECC83 (12AX7, 7025)*	V10	Rectifier	GZ34 (5AR4) *						

* Alternate

ELECTROLYTIC CAPACITORS

ITEM No.	RATING		REPLACEMENT DATA						NOTES
	CAP.	VOLT.	FISHER PART No.	AEROVOX PART No.	CORNELL-DUBILIER PART No.	MALLORY PART No.	PYRAMID PART No.	SPRAGUE PART No.	
C1	60	500	C 729-131	AFH1-62	A0560	FP176	TMS-70	TVL-1958	
C2A	▲40	450	C 729-132	AFH3-44	C0350	TC 83	TMT-40	TVL-3787	
B	■40	450				FP377			
C	▲40	450							
C3	10	350	C 644-146	PRS1620	BR1045	TC 62	TD-10-450	TVA-1604	
C4	10	350	C 644-146	PRS1620	BR1045	TC 62	TD-10-450	TVA-1604	
C5	10	150	C 729-133	SRE150V10	NLW10-150	TT150X10	TD-10-150	TE-1507	
C6	10	150	C 729-133	SRE150V10	NLW10-150	TT150X10	TD-10-150	TE-1507	
C7	25	6	C 639-114	XPP-6025	NLW25-6	TT6X25	TD-25-25	TE-1091	
C8	150	30	C 663-137	PRS1350	BR1505	TC 495	TD-150-50	TVA-1311	
C9	25	6	C 639-114	XPP-6025	NLW25-6	TT6X25	TD-25-25	TE-1091	
C10	150	30	C 663-137	PRS1370	BR1505	TC 495	TD-150-50	TVA-1311	

FIXED CAPACITORS

Capacity values given in the rating column are in mfd. for Paper Capacitors, and in mmfd. for Mica and Ceramic Capacitors.

ITEM No.	RATING			REMARKS	REPLACEMENT DATA						
					AEROVOX PART No.	CENTRALAB PART No.	CORNELL-DUBILIER PART No.	ELMENCO PART No.	MALLORY PART No.	SPRAGUE PART No.	
C11	120	N1500	10%	#C50070-9				*			
C12	.047	250V	10%		V84C4S47-10%		PM4S47	4DP-3-473	GEM-1615	4TM-S47	
C13	.047	250V	10%		V84C4S47-10%		PM4S47	4DP-3-473	GEM-1615	4TM-S47	
C14	68	N750	10%		N750-DI 68	DTN-68	C10Q68U	CCTN-680	CN7-468	10TCU-Q68	
C15	.047	250V	10%		V84C4S47-10%		PM4S47	4DP-3-473	GEM-1615	4TM-S47	
C16	330		10%		DI-330	DD-331	L10T33	CCD-331	GP333	10TS-T33	
C17	200		10%		DI-200	DD-201	L10T2	CCD-201	GP320	10TS-T20	
C18	330		10%		DI-330	DD-331	L10T33	CCD-331	GP333	10TS-T33	
C19	33	N750	10%		N750-DI 33	DTN-33	C10Q33U	CCTN-330	CN7-433	10TCU-Q33	
C20	120	N1500	10%		#C50168-2				*		
C21	68	N750	10%	N750-DI 68		DTN-68	C10Q68U	CCTN-680	CN7-468	10TCU-Q68	
C22	220		10%	DI-220		DD-221	L10T22	CCD-221	GP322	10TS-T20	
C23	.1	500V		P688N-1		DF-104	CUB6P1	6DP-4-104	GEM-601	6TM-P1	
C24	150		10%	DI-150		DD-151	L10T15	CCD-151	GP315	10TS-T15	
C25	.22	500V		P688N-22			CUB6P22	6DP-5-224	GEM-6022	6TM-P22	
C26	.22	500V		P688N-22			CUB6P22	6DP-5-224	GEM-6022	6TM-P22	
C27	330		10%	DI-330		DD-331	L10T33	CCD-331	GP333	10TS-T33	
C28	10	2000V	5%	#C50070-9					*		
C29	330		10%			DI-330	DD-331	L10T33	CCD-331	GP333	10TS-T33
C30	330		10%		DI-330	DD-331	L10T33	CCD-331	GP333	10TS-T33	
C31	.1	500V			P688N-1	DF-104	CUB6P1	6DP-4-224	GEM-601	6TM-P1	
C32	120	N1500	10%		V84C4S47-10%		PM4S47	4DP-3-473	GEM-1615	4TM-S47	
C33	.047	250V	10%		V84C4S47-10%		PM4S47	4DP-3-473	GEM-1615	4TM-S47	
C34	.047	250V	10%		N750-DI 68	DTN-68	C10Q68U	CCTN-680	CN7-468	10TCU-Q68	
C35	68	N750	10%		V84C4S47-10%		PM4S47	4DP-3-473	GEM-1615	4TM-S47	
C36	.047	250V	10%		V84C4S47-10%		PM4S47	4DP-3-473	GEM-1615	4TM-S47	
C37	330		10%		DI-330	DD-331	L10T33	CCD-331	GP333	10TS-T33	
C38	200		10%	DI-200	DD-201	L10T2	CCD-201	GP320	10TS-T20		
C39	330		10%	DI-330	DD-331	L10T33	CCD-331	GP333	10TS-T33		
C40	33	N750	10%	N750-DI 33	DTN-33	C10Q33U	CCTN-330	CN7-433	10TCU-Q33		

FIXED CAPACITORS (cont)

ITEM No.	RATING			REMARKS	REPLACEMENT DATA						
					AEROVOX PART No.	CENTRALAB PART No.	CORNELL-DUBILIER PART No.	ELMENCO PART No.	MALLORY PART No.	SPRAGUE PART No.	
C41	120	N1500	10%	#C50070-9				*			
C42	68	N750	10%		N750-DI 68	DTN-68	C10Q68U	CCTN-680	CN7-468	10TCU-Q68	
C43	220		10%		DI-220	DD-221	L10T22	CCD-221	GP320	10TS-T22	
C44	.1	500V			P688N-1	DF-104	CUB6P1	6DP-4-104	GEM-601	6TM-P1	
C45	150		10%		DI-150	DD-151	L10T15	CCD-151	GP315	10TS-T15	
C46	.22	500V			P688N-22		CUB6P22	6DP-5-224	GEM-6022	6TM-P22	
C47	.22	500V			P688N-22		CUB6P22	6DP-5-224	GEM-6022	6TM-P22	
C48	330		10%		DI-330	DD-331	L10T33	CCD-331	GP333	10TS-T33	
C49	10	2000V	5%		#C50168-2				*		
C50	330		10%			DI-330	DD-331	L10T33	CCD-331	GP333	10TS-T33
C51	330		10%	DI-330		DD-331	L10T33	CCD-331	GP333	10TS-T33	

Fisher Part Number.

* Not normally in distributor's stock. Available thru distributor on order to manufacturer.

CONTROLS

ITEM No.	RATING		REPLACEMENT DATA					INSTALLATION NOTES
	RESISTANCE	WATTS	FISHER PART No.	CENTRALAB PART No.	CLAROSTAT PART No.	CTS-IRC PART No.	MALLORY PART No.	
R1	250K	1/4	R50160-3	JL-254				Level, Channel A
R2	250K	1/4	R50160-3	JL-254				
R3A	5000Ω	1/2	R50103-4	BX-10	A47-5000-S	Q11-114	U14	DC Balance, Channel A
B	Shaft			Not Req.	FKS-1/4	Not Req.	Not Req.	
R4A	10K	1/2	R50103-5	AB-14	A47-10K-S	Q11-116	U20	AC Balance, Channel A
B	Shaft			AK-1	FKS-1/4	Not Req.	Not Req.	
R5A	10K	1/2	R50103-5	AB-14	A47-10K-S	Q11-116	U20	AC Balance, Channel B
B	Shaft			AK-1	FKS-1/4	Not Req.	Not Req.	
R6A	5000Ω	1/2	R50103-4	BX-10	A47-5000-S	Q11-114	U14	DC Balance, Channel B
B	Shaft			Not Req.	FKS-1/4	Not Req.	Not Req.	
R7A	5000Ω	1/2	R50103-4	BX-10	A47-5000-S	Q11-114	U14	Bias
B	Shaft			Not Req.	FKS-1/4	Not Req.	Not Req.	
R8	500Ω	2(WW)	R516-128					Hum Balance, Channel A
R9	500Ω	2(WW)	R516-128					Hum Balance, Channel B

RESISTORS

All wattages 1/2 watt, or less, unless otherwise listed.

ITEM No.	RATING	REMARKS	ITEM No.	RATING	REMARKS	ITEM No.	RATING	REMARKS
R10	47K		R31	1000Ω		R52	1meg 5%	
R11	270K		R32	1000Ω		R53	100K 5%	
R12	470K		R33	100K 2W		R54	47K	
R13	560K		R34	50Ω 5% 5W		R55	100K 5%	
R14	3900Ω		R35	.47Ω 5W		R56	47K	
R15	220Ω		R36	47K		R57	1000Ω	
R16	6800Ω		R37	270K		R58	1000Ω	
R17	120K		R38	470K		R59	100K 2W	
R18	4.7meg		R39	560K		R60	50Ω 5% 5W	
R19	8200Ω		R40	3900Ω		R61	.47Ω 5W	
R20	10K		R41	220Ω		R62	120K	
R21	18K 5% 1W		R42	6800Ω		R63	120K	
R22	22K 5% 1W		R43	120K		R64	5000Ω 5W	
R23	22K 5% 1W		R44	4.7meg		R65	600Ω 5W	
R24	3300Ω		R45	8200Ω		R66	600Ω 5W	
R25	1meg 5%		R46	10K		R67	15Ω 10W	
R26	1meg 5%		R47	18K 5% 1W		R68	15Ω 10W	
R27	100K 5%		R48	22K 5% 1W		R69	15K	
R28	47K		R49	22K 5% 2W		R70	390Ω	
R29	47K		R50	3300Ω				
R30	100K 5%		R51	1meg 5%				

PARTS LIST AND DESCRIPTIONS (Continued)

TRANSFORMER (POWER)

ITEM No.	RATING			REPLACEMENT DATA						
	PRI.	SEC. 1	SEC. 2	FISHER PART No.	Halldorson PART No.	Merit PART No.	Ram PART No.	Stancor PART No.	Thordarson PART No.	Triad PART No.
	T1	117V @ 2.2A	660VCT @ .330A Tap @ 55VAC @ .003A	5V @ 4A	T729-115					
	SEC. 3	SEC. 4	SEC. 5							
	6.3V @ 3.6A	6.3V @ 3.6A								

TRANSFORMER (AUDIO OUTPUT)

ITEM No.	IMPEDANCE		REPLACEMENT DATA						NOTES	
	PRI.	SEC.	FISHER PART No.	Halldorson PART No.	Merit PART No.	Ram PART No.	Stancor PART No.	Thordarson PART No.		Triad PART No.
	T2	4000Ω CT	16Ω Tap @ 8Ω, 4Ω	T729-116						
T3	4000Ω CT	16Ω Tap @ 8Ω, 4Ω	T729-116							

RECTIFIERS

ITEM No.	RATING	REPLACEMENT DATA					NOTES
	CURRENT (Measured)	FISHER PART No.	INTERNATIONAL PART No.	ITT PART No.	SARKES TARZIAN PART No.	SYLVANIA PART No.	
M1	.003A	SR588-128 ①	D-5413 ①		10 ①		① Selenium Type

FUSES

ITEM No.	TYPE	RATING	REPLACEMENT DATA					
			FISHER PART No.		LITTELFUSE PART No.		BUSS PART No.	
			FUSE	HOLDER	FUSE	HOLDER	FUSE	HOLDER
M2	3AG	4A 125V S/B	F729-145		313004 (3AG 4A 125V S/B)	342001	MDX4	HKP

MISCELLANEOUS

ITEM No.	PART NAME	FISHER PART No.	NOTES
M3	Switch	S557-138	Balance

WIRING DATA

General-use Unshielded Hook-up Wire Use BELDEN No. 8530 (Solid) Available in Ten Colors
8524 (Stranded) Available in Ten Colors
Power Cord Use BELDEN No. 1765-B (6 Ft. Length)
1725-K (7½ Ft. Length)

CHASSIS—TOP VIEW

