

Stereophonic

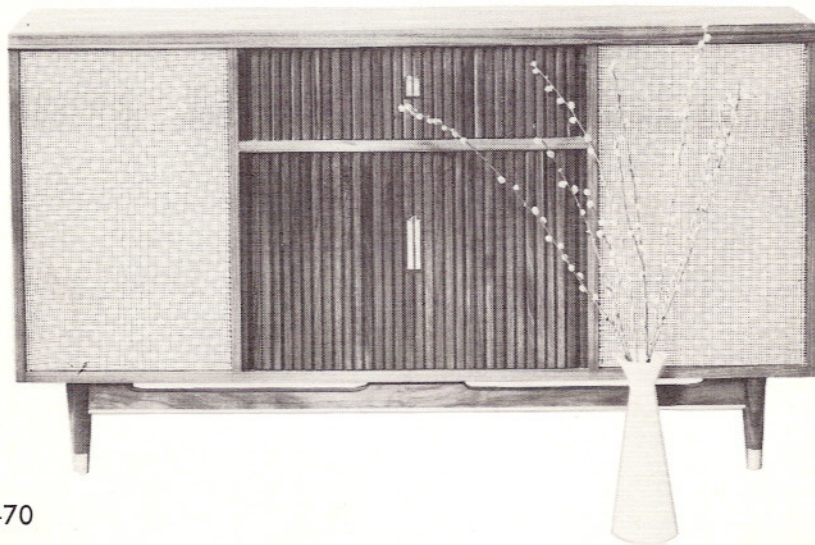

THE FISHER
STATESMAN
SERVICE
MANUAL



MODEL S-70

PRICE: \$1.00

FISHER RADIO CORPORATION • NEW YORK



THE FISHER S-70



PARTS DESCRIPTION LIST • TUNER AND PREAMPLIFIER

CAPACITORS

10% tolerance for all fixed capacitors, unless otherwise noted or marked GMV (guaranteed minimum value.)

Symbol	Description	Part No.
C1	Ceramic, 24uuf 5% N150, 1000V	C50070-8
C2	Ceramic, 8 uuf ± .5uuf NPO; 500V	CC20CJ080D5
C3	Ceramic, 5uuf ± .5uuf NPO; 500V	CC20CJ050D5
C4	Ceramic, 100uuf N1500; 1000V	C50070-6
C5	Ceramic trimmer	C662-123
C6	AM variable	C684-127
C7	FM variable	C726-116
C8	Ceramic, 100 uuf GMV, N1500; 1000V	C50070-5
C9	Ceramic, 100 uuf N1500; 1000V	C50070-6
C10, 11, 12	Ceramic, Feedthru, .001 uf GMV	C592-187
C13	Ceramic, .02uf + 80 — 20%; 500V	C50089-4
C14	Ceramic, Feedthru, .001 uf; GMV	C592-187
C15	Ceramic, .02uf + 80 — 20%; 500V	C50089-4
C16	Ceramic, .001uf; 1000V	C50072-3
C17	Ceramic, .02uf + 80 — 20%; 500V	C50089-4
C18	Ceramic, .005uf 20%; 500V	C50089-1
C19	Ceramic, 8uuf ± .5uuf; NPO, 500V	CC20CJ080D5
C20	Ceramic, .68uuf, 500V	C50077-6N
C21	Ceramic, Trimmer	C662-123
C22	Ceramic, 10uuf ± .5uuf, NPO; 500V	CC20CJ100D5
C23	Ceramic, 100uuf, N1500; 1000V	C50070-6
C24	Ceramic, 100uuf, GMV, N1500, 1000V	C50070-5
C25	Ceramic, 68uuf, N750; 500V	CC20UJ680K5
C26	Ceramic, 100uuf, N1500; 1000V	C50070-6
C27	Molded, .01uf 20%; 600V	C2747
C28	Ceramic, 5uuf ± .5uuf N150, 500V	CC20PJ050D5
C29	Ceramic, 5uuf ± .5uuf N220, 500V	CC20RH050D5
C30	Ceramic, 47uuf N750; 1000V	C50070-4
C31	Ceramic, trimmer	C662-123
C32	Ceramic, feedthru .001uf GMV	C592-187
C33	Ceramic, 10uuf ± .5uuf NPO; 500V	CC20CJ100D5
C34	Ceramic, 24uuf 5%; N150; 1000V	C50070-8
C35	Ceramic, 100uuf GMV, N1500; 1000V	C50070-5
C36	Ceramic, 100uuf 5%, N1500; 1000V	C50070-19
C37	Ceramic, .001uf, 1000V	C50072-3
C38	Ceramic, feedthru .001 uf GMV	C592-187
C39, 40	Ceramic, .02uf + 80 — 20% 500V	C50089-4
C41	Ceramic, .005uf 20%; 500V	50089-1
C42	Electrolytic four section: A 40uf 350V B 40uf 300V C 40uf 300V D 40uf 250V	C50180-3
C43	Electrolytic to section: A 1000uf 30V B 1000uf 30V	C50180-7
C44	Ceramic feedthru .001uf GMV	C592-187
C45	Mica, 470uuf 5%, 300V	C3334
C46, 47	Ceramic, .005uf 20%; 500V	C50089-1
C48	Ceramic, .0027uf, 1000V	C50072-17
C49	Electrolytic, three section: A 40uf 250V B 40uf 250V C 40uf 250V	C50180-4
C50, 51, 52	Ceramic, .005uf 20%; 500V	C50089-1
C53	Mica, 470uuf, 5%; 300V	C3334
C54	Mylar, .047 uf; 250V	C50197-52
C55	Electrolytic, two section: A 40uf 250V B 40uf 250V	C50180-5
C56	Ceramic, .005uf 20%; 500V	C50089-1
C57	Ceramic, .02uf + 80 — 20%; 500V	C50089-4
C58	Ceramic, .0027uf, 1000V	C50072-17
C59	Ceramic, .02uf + 80 — 20%; 500V	C50089-4
C60, 61	Ceramic, .005uf 20%; 500V	C50089-1
C62	Mica, 470 uuf 5%; 300V	C3334
C63, 64	Ceramic, .005uf, 20%, 500V	C50089-1
C65	Ceramic, 47uuf, N750; 1000V	C50070-4
C66	Ceramic, 220uuf 1000V	C50072-20
C67	Mica, 470uuf 5%; 300V	C3334
C68	Ceramic, 220 uuf, 1000V	C50072-20
C69	Ceramic, .0027uf; 1000V	C50072-17
C70	Ceramic, .005uf 20%; 500V	C50089-1
C71	Ceramic, .02uf + 80 — 20%; 500V	C50089-4
C72	Ceramic, 5uuf ± .5uuf, NPO; 500V	CC20CJ050D5
C73	Ceramic, 24uuf, 5%; 1000V	C50070-8
C74	Ceramic, .005uf 20%; 500V	C50089-1
C75	Electrolytic, 2uf; 70V	C721-142
C76	Mylar, .1uf 10%; 250V	C50197-54
C77, 78	Ceramic, .005uf 20%; 500V	C50089-1
C79	Ceramic, 1uuf, 20% P100; 100V	C50070-1
C80	Ceramic, .005uf 20%; 500V	C50089-1
C81	Ceramic, 560uuf; 1000V	C50072-14
C82	Ceramic, 12uuf; NPO, 1000V	C50070-2
C83, 84	Ceramic, .005uf 20%, 500V	C50089-1
C85	Mica trimmer	C629-151-5
C86	Ceramic, .0027uf 1000V	C50072-17
C87	Ceramic, 12uuf, NPO, 1000V	C50070-2
C88	Mylar, .047uf, 250V	C50197-52
C89	Ceramic, .005uf 20%; 500V	C50089-1
C90	Ceramic, 220uf, 1000V	C50072-20
C91	Mylar, .047uf 250V	C50197-52
C92	Ceramic, .005uf 20%; 500V	C50089-1
C93	Ceramic, .02uf + 80 — 20%, 500V	C50089-4
C94, 95	Ceramic, 330uuf, 1000V	C50072-1
C96	Mylar, .015uf, 250V	C50197-58
C97	Ceramic, 820uuf, 5%; 500V	CC21GP821J5
C98	Ceramic, 330uuf, 1000V	C50072-1
C99	Ceramic, .0033uf; 1000V	C50072-11
C100	Electrolytic, 8uf, 50V	C629-138
C101	Mylar, .1uf, 250V	C50197-54
C102	Ceramic, .005uf, 20%; 500V	C50089-1
C110, 111	Ceramic, 220uuf, 1000V	C50072-20
C112, 113	Ceramic, 100uuf, GMV; 1000V	C50070-5
C114, 115	Mylar, .01uf, 250V	C50197-48
C116, 117	Mylar, .022uf, 250V	C50197-49
C118, 119	Ceramic, 33uuf, 5%, N750, 1000V	C50070-25K
C120, 121	Ceramic, 2700uuf; 1000V	C50072-17
C122	Ceramic, .0033uf; 1000V	C50072-11
C123	Electrolytic, 25uf; 6V	C639-114
C124	Ceramic, .0033uf; 1000V	C50072-11
C125	Electrolytic, 25uf, 6V	C639-114
C126, 127	Mylar, .047uf, 250V	C50197-52
C128, 129	Ceramic, .005uf, 20%; 500V	C50089-1
C130, 131	Mylar, .68uf; 250V	50197-57
C132, 133	Mylar, .027uf, 250V	50197-50
C134, 135	Ceramic, 330uuf; 1000V	C50072-11
C136, 137	Ceramic, 24uuf 5% N150 1000V	C50070-8
C138, 139	Mylar, .1uf; 250V	C50197-54
C140	Electrolytic, 25uf, 6V	C639-114
C141	Ceramic, .001uf; 1000V	C50072-3
C142	Electrolytic, 25uf; 6V	C639-114
C143	Ceramic, .001uf; 100V	C50072-3
C144, 145	Electrolytic, 25uf; 6V	C639-114
C146, 147	Mylar, .1uf; 250V	C50197-54
C148, 149	Ceramic, .02uf + 80 — 20%; 500V	C50089-4
C150, 151, 152, 153, 154	Mylar, .1uf; 250V	C50197-54
C155, 156	Ceramic, .001uf, GMV, 500V	C50089-2
C157	Electrolytic, 8uf, 50V	C629-138
C158	Mylar, .047uf, 250V	C50197-52
C159	Electrolytic, 1uf, 250V	C546-126
C160, 161	Ceramic, 330uuf, 1000V	C50072-1

RESISTORS AND POTENTIOMETERS

In ohms, 10% tolerance, 1/2 watt, unless otherwise noted. K = kilohm, M = megohm.

Symbol	Description	Part No.
R1	Composition 330	RC20BF331K
R2	Composition 2.7K	RC20BF272K
R3	Composition 330	RC20BF331K
R4	Composition 1K	RC20BF102K
R5	Composition 4.7	RC20BF477K
R6	Composition 100K	RC20BF104K
R7	Composition 4.7M	RC20BF475K
R8	Composition 120	RC20BF121K
R9	Composition 3.3M	RC20BF335K
R10	Composition 120	RC20BF121K
R11, 12	Composition 330K	RC20BF334K
R13	Composition 47K	RC20BF473K
R14	Composition 1K	RC20BF102K
R15	Composition 22	RC20BF220K
R16	Composition 2.2K	RC20BF222K
R17	Composition 4.7	RC20BF477K
R18	Composition 820K	RC20BF824K
R19	Composition 1K	RC20BF102K
R20	Composition 100	RC20BF101K
R21	Composition 470K	RC20BF474K
R22	Composition 22K	RC20BF223K
R23	Composition 1K	RC20BF102K
R24	Composition 2.2K, 1W	RC30BF222K
R25	Wirewound 100, 5W	R592-185
R26	Composition 22K; 1W	RC30BF223K
R27	Composition 120	RC20BF121K
R28	Composition 1.2K; 1W	RC30BF122K
R29	Wirewound 400, 5%; 5W	R621-130
R30	Wirewound 12, 5W	R721-141

R31 Composition 1K
R32 Composition 1.2K, 1W
R33 Wirewound 400, 5%; 5W
R34 Composition 47K
R35 Composition 82K
R36 Composition 1.8M
R37, 38 Composition 1K
R39, 40 Composition 270
R41 Composition 1K
R42 Composition 10K
R43 Composition 68K
R44 Composition 470K
R45 Composition 120
R46 Composition 100
R47 Composition 10K
R48 Composition 100K
R49 Composition 1.8M
R50 Composition 15M
R51 Composition 3.3M
R52 Composition 68K
R53 Composition 56K
R54 Composition 470
R55 Composition 470K
R56 Potentiometer 250K; muting
R57 Composition 1K
R58 Composition 220K
R59 Composition 470K
R60 Composition 47K
R61 Composition 150K
R62 Composition 100K
R63, 64 Composition 270
R65 Composition 1.2M
R66 Composition 100K
R67 Composition 82K
R68 Composition 2.2M
R69 Composition 1K
R70 Composition 220K
R71 Composition 820K
R72 Potentiometer 250K, AM level set
R73 Composition 15K
R74 Composition 220K
R75 Composition 1K
R76 Composition 220K
R77 Composition 27K
R78 Composition 100
R79 Composition 18K
R80 Composition 47K
R81 Composition 1K
R82 Composition 47K
R83 Composition 22K, 1W
R84 Composition 1K
R85 Composition 3.3M
R86 Composition 270
R87 Composition 180
R88 Composition 470K
R89 Composition 100K, 5%
R90 Composition 68K
R91 Composition 1.5K
R92 Composition 1K
R93, 94 Composition 6.8K
R95 Composition 330K
R96 Composition 33K, 5%
R97 Potentiometer 100K, MPX, Control
R105 Potentiometer 250K, Tape rec. level ch. A
R106, 107 Composition 82K
R108 Potentiometer, 250K, Tape rec. level ch. B
R109 Composition 100K
R110 Composition 10K
R111 Composition 100K
R112 Composition 10
R113 Composition 10K
R114 Composition 10
R115 Composition 330K, 1W
R116 Composition 2.7K, 1W
R117 Composition 330K, 1W
R118 Composition 2.7, 1W
R119, 120 Composition 4.7M
R121, 122 Composition 220K
R123, 124 Potentiometer, 250K, Phono Level Sets
R125, 126 Composition 470K
R127, 129 Composition, 3 9M
R128 Composition 470K
R130 Composition 470K
R131, 132 Composition 470
R133 Composition 270K
R134, 135 Composition 330K
R136 Composition 270K
R137, 138 Composition 47K

RC20BF102K
RC30BF122K
R621-130
RC20BF473K
RC20BF823K
RC20BF185K
RC20BF102K
RC20BF271K
RC20BF102K
RC20BF103K
RC20BF683K
RC20BF474K
RC20BF121K
RC20BF101K
RC20BF103K
RC20BF104K
RC20BF185K
RC20BF156K
RC20BF335K
RC20BF683K
RC20BF563K
RC20BF471K
RC20BF474K
R50160-3
RC20BF102K
RC20BF224K
RC20BF474K
RC20BF473K
RC20BF154K
RC20BF104K
RC20BF271K
RC20BF125K
RC20BF104K
RC20BF823K
RC20BF225K
RC20BF102K
RC20BF224K
RC20BF824K
R50160-3
RC20BF153K
RC20BF224K
RC20BF102K
RC20BF224K
RC20BF273K
RC20BF101K
RC20BF183K
RC20BF473K
RC20BF102K
RC20BF473K
RC30BF223K
RC20BF102K
RC20BF335K
RC20BF271K
RC20BF181K
RC20BF474K
RC20BF104J
RC20BF683K
RC20BF152K
RC20BF102K
RC20BF682K
RC20BF334K
RC20BF333J
R50160-20
R50160-3
RC20BF823K
R50160-3
RC20BF104K
RC20BF103K
RC20BF104K
RC20BF100K
RC20BF103K
RC20BF100K
RC30BF334K
RC30BF272K
RC30BF334K
RC30BF272K
RC20BF475K
RC20BF224K
R50160-3
RC20BF474K
RC20BF395K
RC20BF474K
RC20BF474K
RC20BF471K
RC20BF274K
RC20BF334K
RC20BF274K
RC20BF473K

R139, 140 Composition 470K
R141 Composition 220
R142 Composition 10K
R143 Composition 220
R144, 145 Composition 10K
R146, 147 Composition 22K
R148 Composition 10K
R149 Potentiometer, dual, 100K, volume
R150 Potentiometer, dual, 1M, Bass
R151 Potentiometer, dual, 500K, treble
R152, 153 Composition 10M
R154, 155 Composition 470K
R156, 157 Composition 1.8K
R158, 159 Composition 100K
R160, 161 Composition 2.2M
R162 Composition 100K
R163 Composition 1.8K
R164 Composition, 1.5M
R165 Composition 100K
R166 Composition 1.8K
R167 Composition, 1.5M
R168 Potentiometer, triple, 500K, balance
250K, center ch. volume
R169, 170 Composition 1M
R171, 172 Composition, 68K, 5%
R173 Composition, 330K, 5%
R174 Composition, 1.5K
R175 Composition, 47K
R176 Composition 1.5K
R177 Composition 47K
R178 Composition, 470K, 5%
R179 Composition, 47K
R180 Composition 470K
R181 Composition 1M
R182, 183 Composition, 470K

RC20BF474K
RC20BF221K
RC20BF103K
RC20BF221K
RC20BF103K
RC20BF223K
RC20BF103K
R50160-29
R50160-30
R50160-28
RC20BF105K
RC20BF474K
RC20BF182K
RC20BF104K
RC20BF225K
RC20BF104K
RC20BF182K
RC20BF155K
RC20BF104K
RC20BF182K
RC20BF155K
R50160-31
RC20BF105K
RC20BF683J
RC20BF334J
RC20BF152K
RC20BF473K
RC20BF152K
RC20BF473K
RC20BF474J
RC20BF473K
RC20BF474K
RC20BF105K
RC20BF474K

COILS, CHOKES AND TRANSFORMERS

Symbol	Description	Part No.
L1	Choke, 3.3 micro henries	L50066-8
L2	Coil, FM Antenna	L726-124
L3	Coil, AM Antenna	L721-139
L4	AM Ferrite Antenna	L721-136
L5	Choke, 1 micro henry	L50066-2
L6, 7	Choke, .56 micro henries	L50066-19
L8	Choke, R.F.	L629-180
L9	Coil, FM, R.F.	L726-126
L10	Coil, FM, osc.	L726-125
L11	Choke, .56 micro henries	L50066-19
L12, 13	Choke, 1 micro henry	L50066-2
L14	Choke, 1.2 micro henries	L50066-3
L15	Coil, AM, osc.	L50210-22
L16	Coil, muting, osc.	L50210-21
L17	Coil, 10KC, filter	L644-120
L18	Choke, 1.2 micro henries	L50066-3
L19, 20	Choke, filament ferrite bead	L592-189
21, 22, 23		
T1	Transformer, power	T721-115
Z1	Transformer, FM, I.F.	ZZ662-117
Z2	Transformer, FM, I.F.	ZZ629-142
Z3	Transformer, FM, I.F.	ZZ50210-2
Z4	Coil, FM, limiter	L551-121
Z5	Transformer, FM, Ratio Detector	ZZ592-170
Z6	Transformer, AM, R.F.	L670-151
Z7, 8	Transformer, AM, I.F.	ZZ50210-3
Z9	Transformer, AM, I.F.	ZZ2984

MISCELLANEOUS

Symbol	Description	Part No.
CR1, 2	Crystal diode, Type 1N295	V-1N295
CR3, 4	Crystal diode, Type 1N542, matched pair	V-1N542
F1	Fuse, 3 amp.	F-3000
I1, 2	Lamp, dial panel	I-50082-3
P1, 2	Plug, 9-pin	P-50181
PC1, 2	Printed circuit, Phone Equalization	PC50187-3
PC3,5	Printed circuit, Tone Control	PC657-140
PC4, 6	Printed circuit, High Freq. filter	PC50187-2
S1	Switch, selector	S721-144
S2	Switch, mono stereo	S721-145
S3, 5, 6, 7, 8, 9, 11, 12	Switch slide	S50200-2 or S50200-4
S4	Switch, power	Part of R149
S10	Switch, loudness	Part of R149
SR1	Selenium rectifier	SR721-143

ALIGNMENT INSTRUCTIONS

Read These Instructions With Extreme Care Before Attempting Alignment.

CHASSIS: Turn the station selectors completely counterclockwise, without forcing. Dial pointers should be at zero index mark on logging scale. If not, reset the dial pointers. Disconnect the external antennas and the antenna link. Set Ferrite Loop to normal position, parallel to rear panel. When using an oscilloscope for alignment, set the output level controls for no overload, as shown by the proper waveform shape.

SIGNAL GENERATORS: The signal generator equipment must be able to supply the following: FM RF modulated 30% (± 22.5 KC deviation) at 400 cps; AM RF modulated 30% at 400 cps;

AM IF with 30 KC sweep for AM bandwidth adjustment; audio oscillator accurately calibrated for 1 and 10 KC audio output for testing the 10 KC AM whistle filter.

INDICATOR: DC VTVM, AC VTVM, and scope for alignment.

ALIGNMENT: Allow the chassis and test instruments to warm up for at least fifteen minutes. Adjust the line voltage for 117 volts AC, 50-60 cycles. Use fully insulated tools: a small screwdriver for all trimming capacitors; a K-Tran tool for Z1, Z2, Z3, Z6, Z7, Z8 and Z9; a hex tool for Z4, Z5, L2, L9, L10, L15 and L16. For AM alignment, connect a 1.4 volt battery between the junction of R68/C54 and ground. Positive side of battery to ground.

AM ALIGNMENT

STEPS	CHASSIS				SIGNAL GENERATOR			INDICATOR		ALIGNMENT	
	AM BANDWIDTH	SELECTOR	MONO-STEREO	STATION SELECTOR	COUPLING	FREQ.	MOD.	TYPE	CONNECTION	ADJUST	INDICATION
1	SHARP	FM-AM	B (AM)	Point of no signal and no interference	Audio Gen. connected to Pin 7 of V12	10 KC	None	AC VTVM to Ch. B Recorder Output		C85	Minimum Output
2	SHARP	FM-AM	B (AM)	Point of no signal and no interference	AM RF Gen. connected thru .01-uf cap. in series with hot lead to V10 Pin 1	455 KC	30% AM at 400 cps	DC VTVM to Test Point 7		Z7, Z8, Z9 top and bottom	Maximum negative voltage
3	BROAD	FM-AM	B (AM)	Point of no signal and no interference	AM Gen. connected thru .01-uf cap. in series with hot lead to V10 Pin 1	455 KC	30 KC sweep	Scope to Ch. B Recorder Output		Z9 top	Adjust slightly for symmetrical curve
4	SHARP	FM-AM	B (AM)	600 KC	AM Gen. connected thru 220-uuf cap. in series with hot lead to antenna terminal 3	600 KC	30% AM at 400 cps	Scope to Ch. B Recorder output. DC VTVM to Test Point 7		L15, Z6	Check for sine waveform Maximum negative voltage
5	SHARP	FM-AM	B (AM)	1400 KC	AM Gen. connected thru 220-uuf cap. in series with hot lead to antenna terminal 3	1400 KC	30% AM at 400 cps	Scope to Ch. B Recorder output. DC VTVM to Test Point 7		C6E, C6C C6A	Check for sine waveform Maximum negative voltage
6	Repeat steps 4 and 5 for proper dial calibration and maximum output.										
7	FM Muting Switch Off	FM-AM	A (FM)	Point of no signal and no interference	FM Generator connected to Pin 1 of V4	10.7 MC	None	Connect VT VM to test point 2		Z4, Z5 top Z5 bottom	Maximum negative voltage (below -5 volts) See Note 2
8	FM Muting Switch Off	FM-AM	A (FM)	Point of no signal and no interference	FM Generator connected to Pin 1 of V4	10.7 MC	None	DC VTVM to test point 4		Z5 top	Zero reading on zero center scale
9	FM Muting Switch Off	FM-AM	A (FM)	Point of no signal and no interference	FM Gen. connected to ungrounded tube shield of V2	10.7 MC	None	DC VTVM to test point 1		Z1, Z2, Z3 top & bottom	Maximum negative voltage (below -2 volts) See Note 2
10	FM Muting Switch Off	FM-AM	A (FM)	90 MC	FM Gen. connected thru two 120-ohm carbon resistors in series with lead to antenna terminals 5 and 6	90 MC	30% FM (22.5 KC Dev.) at 400 cps	DC VTVM to test point 1, and scope to Ch. A Recorder Output		L10, L9 L2	Check for sine waveform and adjust for maximum negative voltage
11	FM Muting Switch Off	FM-AM	A (FM)	106 MC	FM Gen. connected thru two 120-ohm carbon resistors in series with lead to antenna terminals 5 and 6	106 MC	30% FM (22.5 KC Dev.) at 400 cps	DC VTVM to test point 1, and scope to Ch. A Recorder Output		C31, C21 C5	Check for sine waveform and adjust for maximum negative voltage
12	Repeat steps 10 and 11 at least once for proper dial calibration and maximum output.										
<p>NOTE: 1 — For calibrating both the AM and FM, use as low an output voltage as possible from your signal generator. 2 — Decrease Signal Generator output while adjusting IF transformers so that DC VTVM shows no more than noted voltage. 3 — If adjustment of muting oscillator is necessary, adjust it for 3 MC with a Grid-dip Meter.</p>											

FM ALIGNMENT

SCHEMATIC DIAGRAM • FM-AM TUNING SECTIONS

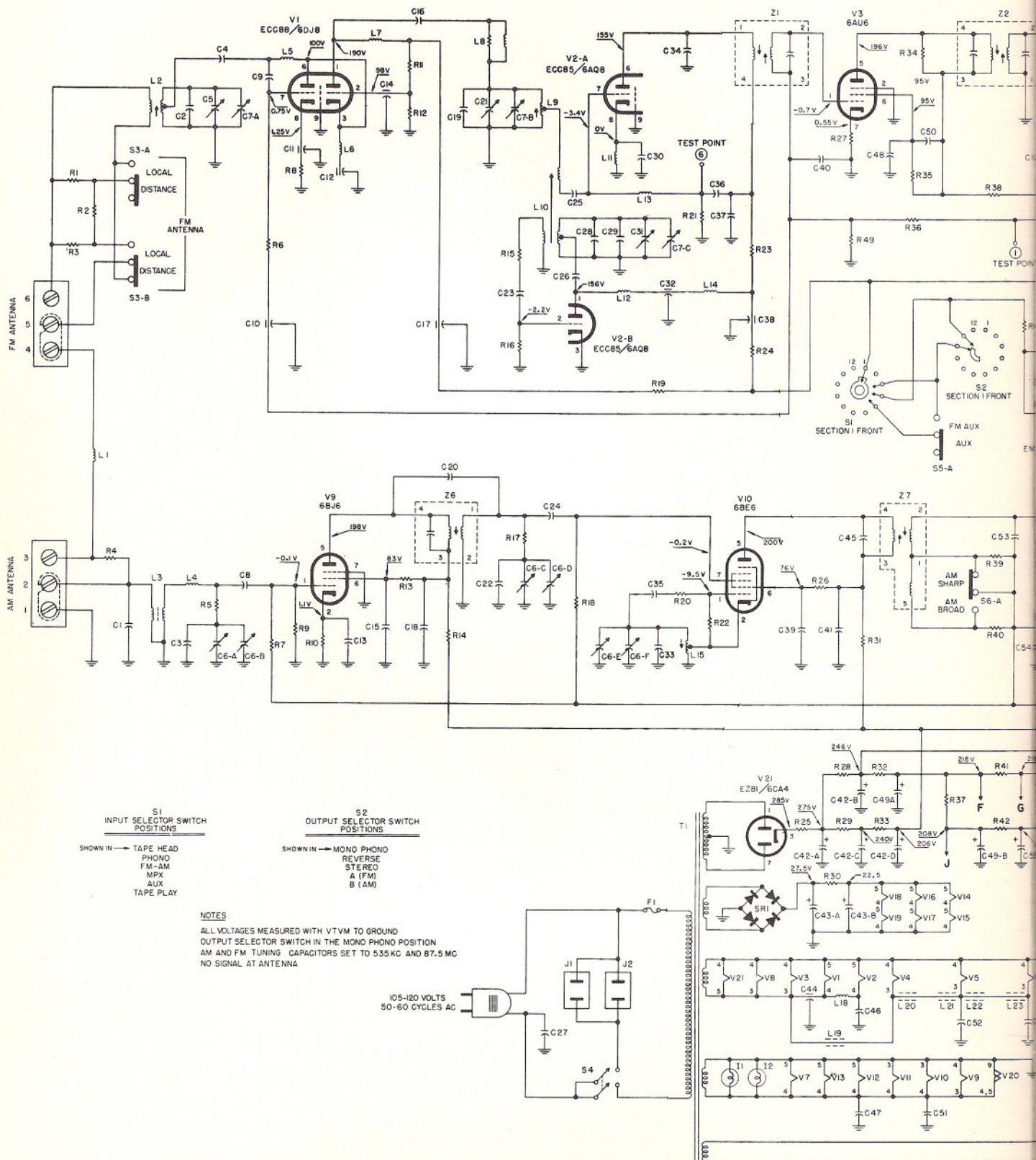

RESISTORS	R1 R2 R3	R4	R5	R6 R7	R8 R9 R10	R11 R12 R13	R14	R15 R16 R17	R18	R19 R20	R21	R22	R23 R24	R25 R26 R27 R28 R29 R30	R31 R32 R33 R34 R35 R36	R37	R38 TO R42	R41 R42
CAPACITORS	C1	C2 C3	C4 C5 C6-A C6-B C6-C C6-D C6-E C6-F C6-G C6-H C6-I C6-J C6-K C6-L C6-M C6-N C6-O C6-P C6-Q C6-R C6-S C6-T C6-U C6-V C6-W C6-X C6-Y C6-Z	C7-A C7-B C7-C C7-D C7-E C7-F C7-G C7-H C7-I C7-J C7-K C7-L C7-M C7-N C7-O C7-P C7-Q C7-R C7-S C7-T C7-U C7-V C7-W C7-X C7-Y C7-Z	C8 C9 C10 C11 C12 C13 C14 C15 C16 C17 C18 C19 C20 C21 C22 C23 C24 C25 C26 C27 C28 C29 C30 C31 C32 C33 C34 C35 C36 C37 C38 C39 C40 C41 C42 C43 C44 C45 C46 C47 C48 C49 C50 C51 C52 C53 C54 C55 C56													

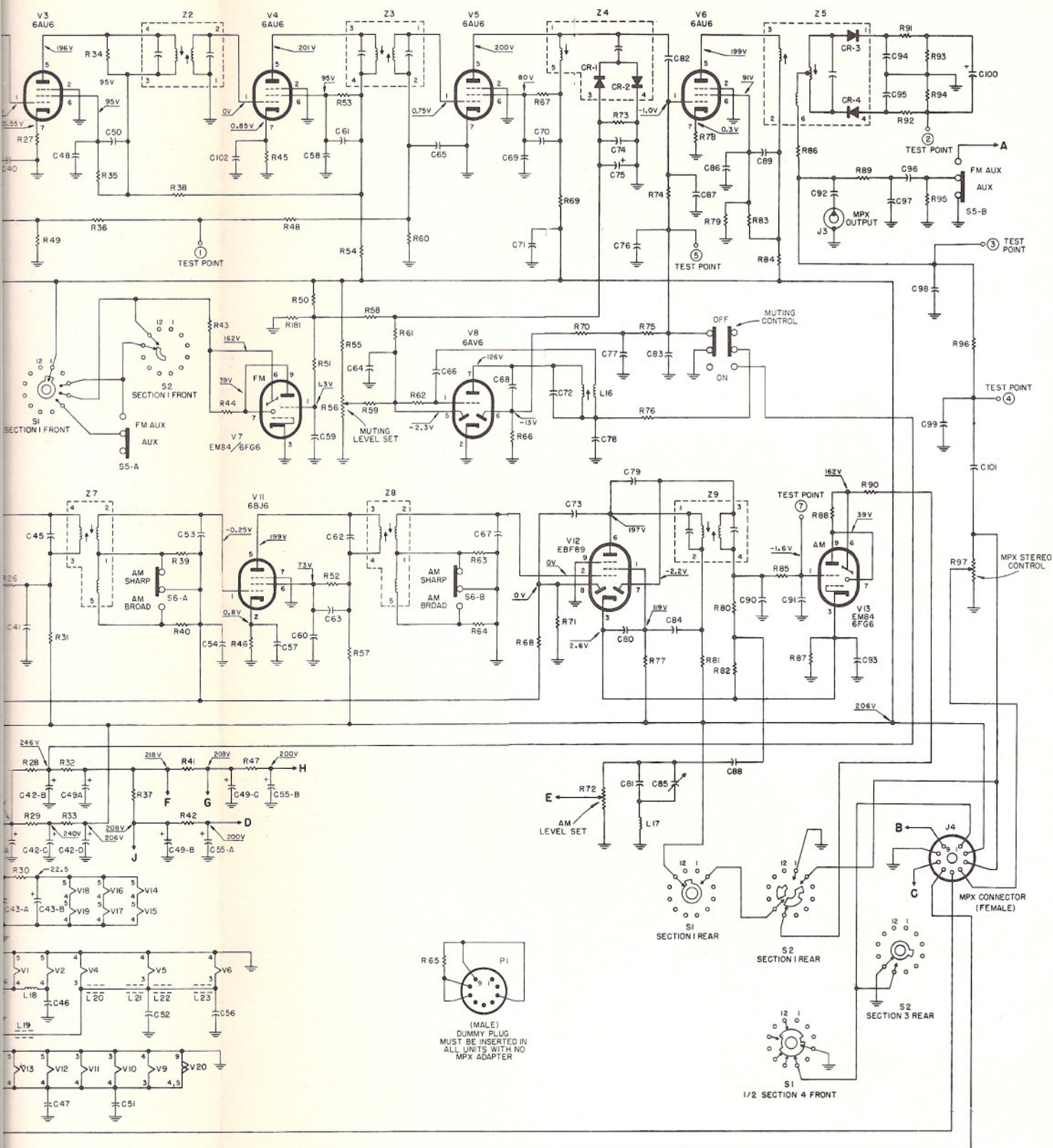

R27 TO R30	R31 TO R33	R34 TO R36	R37 TO R39	R38 TO R42	R43 TO R47	R45 TO R50	R48 TO R50	R51 TO R59	R60 TO R62	R63 TO R65	R66 TO R68	R69 TO R72	R73 TO R77	R74 TO R77	R78 TO R82	R83 TO R87	R85 TO R87	R88 TO R90	R89 TO R92	R91 TO R95	R93 TO R95	R96 TO R97	C100 TO C101
C40 TO C44	C45 TO C47	C48 TO C50	C51 TO C52	C53 TO C56	C57 TO C60	C61 TO C63	C64 TO C66	C65 TO C69	C67 TO C71	C70 TO C73	C72 TO C75	C74 TO C78	C79 TO C81	C82 TO C85	C86 TO C88	C89 TO C90	C91 TO C93	C92 TO C94	C95 TO C97	C98 TO C99	C100 TO C101		

SCHEMATIC DIAGRAM • PREAMPLIFIER

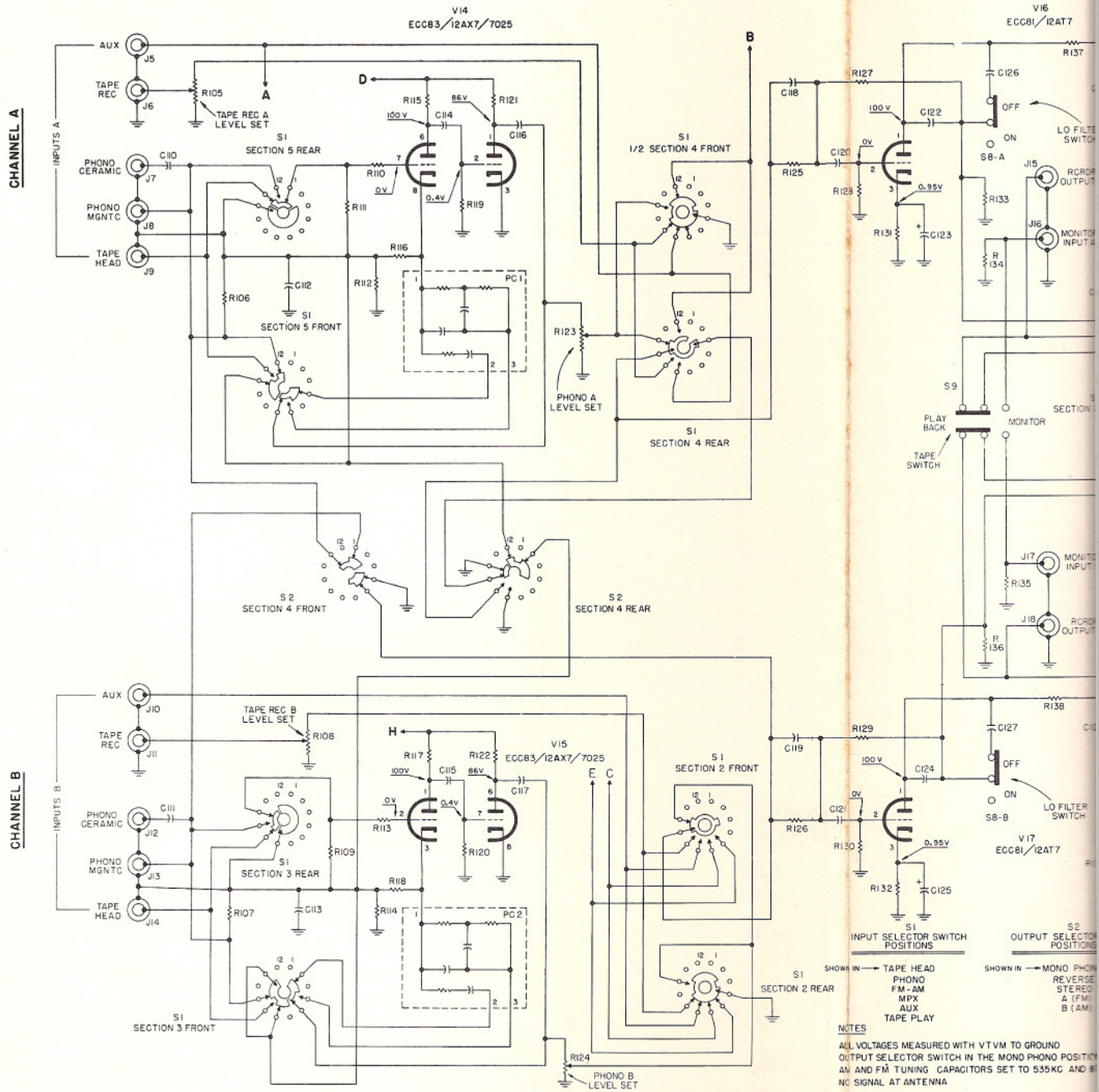

RESISTORS	R105	R106	R108	R109	R110	R115	R119	R121	R123	R125	R127	R131	R133	R137
		R107			TO R14	TO R18	R120	R122	R124	R126		R132	TO R136	R138
CAPACITORS	C10	C11	C12	C13	C14	C15	C16	C17	C18	C19	C20	C22	C26	
											TO R10	TO C25		

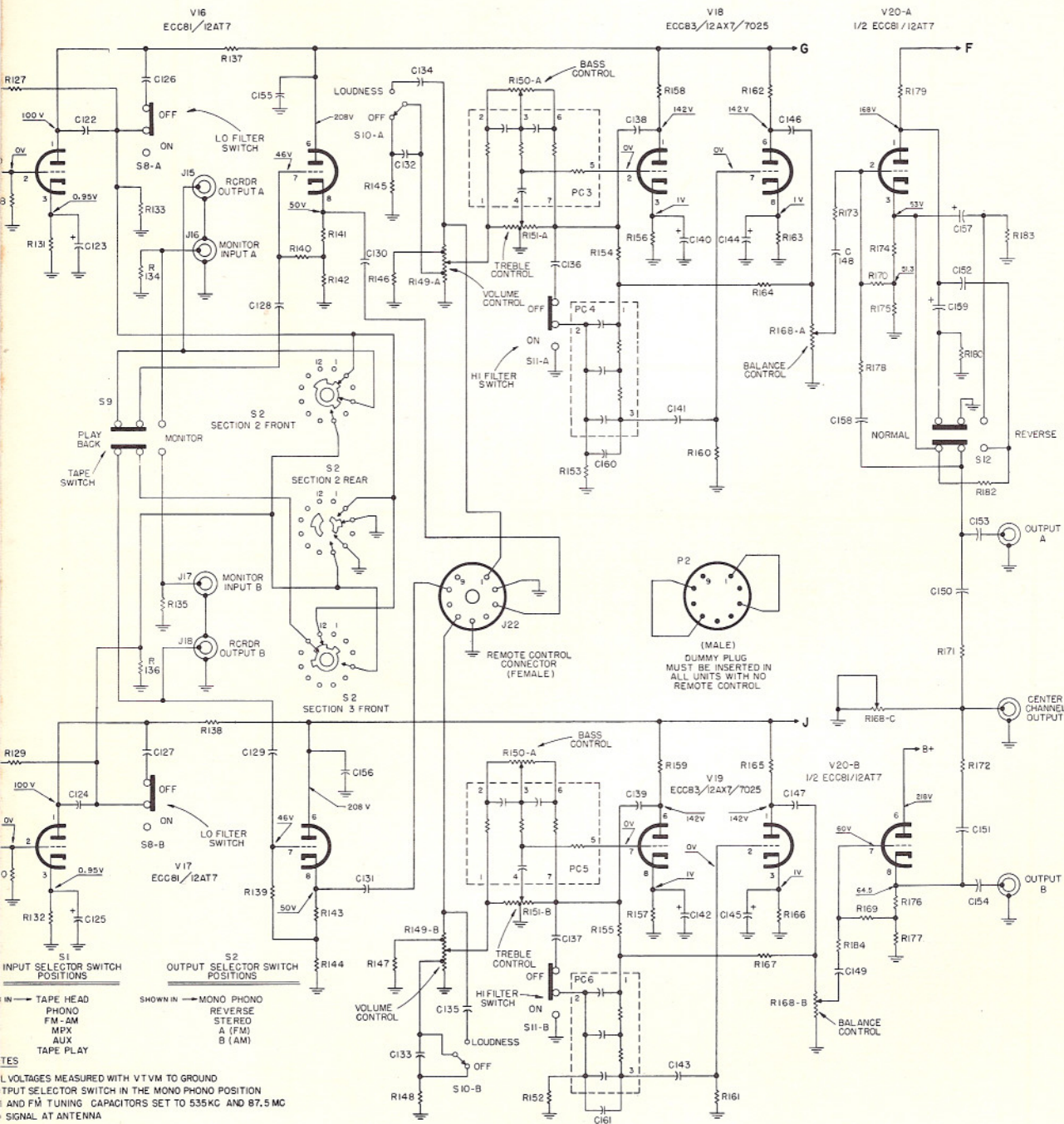

SCHEMATIC DIAGRAM • AMPLIFIER

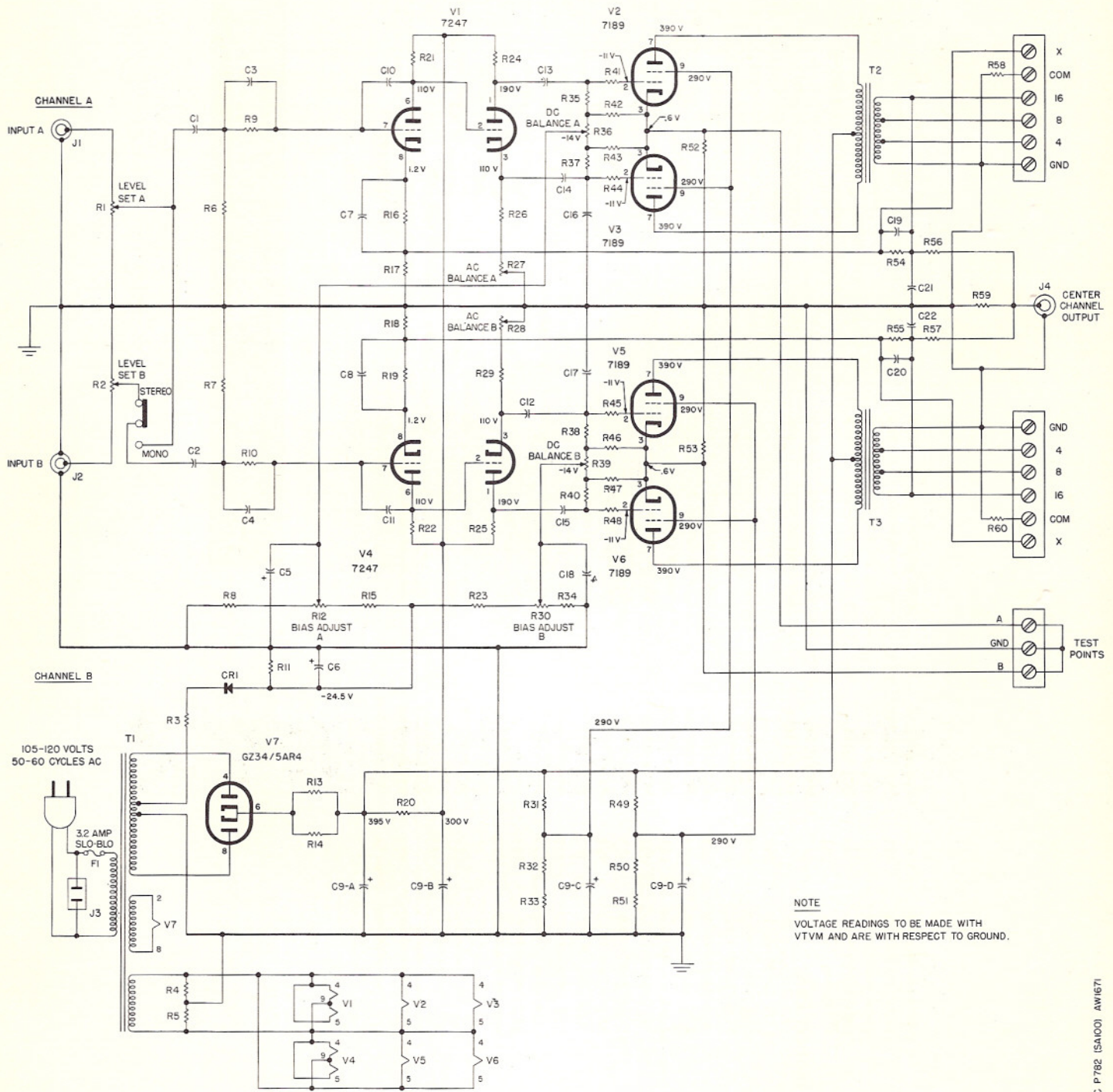

NOTE
VOLTAGE READINGS TO BE MADE WITH
VTVM AND ARE WITH RESPECT TO GROUND.

RESISTORS	R1 R2	R3 R4 R5	R6 R7 R8	R9 R10 R11	R12 R13 R14	R15 R16 R17 R18	R19 R20 R21	R22 R23	R24 R25 R26	R27 R28 R29	R30 R31 R32	R33 R34 R35	R36 R37 R38 R39	R40 R41 R42 R43 R44	R45 R46 R47 R48 R49	R50 R51 R52 R53	R54 R55	R56 R57	R58 R59 R60	
CAPACITORS	C1 C2	C3 C4	C5 C6	C7 C8 C9-A	C10 C11 C9-B	C12 C13	C14 C15 C16 C17 C18	C19	C20 C21 C22											

PARTS DESCRIPTION LIST • AMPLIFIER

CAPACITORS

10% Tolerance for all fixed capacitors, unless otherwise noted or marked GMB (guaranteed minimum value.)

Symbol	Description	Part Number
C1, 2	Mylar .022uf; 250V	C50197-49
C3, 4	Ceramic, 15uuf, N75; 1000 V	C50070-18
C5, 6	Electrolytic, 50uf; 50V	C782-119
C7, 8	Electrolytic, 25uf; 6V	C639-114
C9	Electrolytic, 4 section	C50180-10
	A. 40uf; 450V	
	B. 40uf; 450V	
	C. 10uf; 450V	
	D. 10uf; 450V	
C10, 11	Ceramic, 2uuf, NPO; 1000V	C50070-23
C12, 13, 14, 15	Mylar, .047uf; 400V	C50197-30
C16	Ceramic, 12uuf, NPO; 1000V	C50070-2
C17	Ceramic, 5uuf, NPO; 1000V	C50070-24
C18	Electrolytic, 50uf, 50V	C782-119
C19, 20	Ceramic, 270uuf, 1000V	C50072-16
C21, 22	Ceramic, 330uuf, 1000V	C50072-1

RESISTORS AND POTENTIOMETERS

In ohms, 10% tolerance, 1/2 Watt, unless otherwise noted. K=kilohm, M=megohm.

R1, 2	Potentiomer, 250K, Level sets	R50103-1
R3	Wirewound, 2.2K, 2 W.	R782-121

Symbol Description

R4, 5	Composition, 220
R6, 7	Composition, 1M
R8	Composition, 10K
R9, 10	Composition, 47K
R11	Composition, 4.7K
R12	Potentiometer, 5K, bias adjust Ch. A.
R13, 14	Wirewound, 250, 7W
R15	Composition, 4.7K
R16	Composition, 3.9K
R17, 18	Composition, 220
R19	Composition, 3.9K
R20	Composition, 22K, 2W
R21, 22	Composition, 680K
R23	Composition, 4.7K
R24, 25	Composition, 68K, 1W
R26	Composition, 39K
R27, 28	Potentiometer, 50K, AC balance
R29	Composition, 39K
R30	Potentiometer, 5K, bias adjust ch. B
R31	Wirewound, 4K, 5W.
R32, 33	Wirewound, 7.5K, 7W.
R34	Composition, 10K
R35	Composition, 220K

Part Number

RC20BF221K
RC20BF105K
RC20BF103K
RC20BF473K
RC20BF472K
R50103-4
R539-121
RC20BF472K
RC20BF392K
RC20BF221K
RC20BF392K
RC40BF223K
RC20BF684K
RC20BF472K
RC30BF683K
RC20BF393K
R50103-3
RC20BF393K
R50103-4
R692-130
R740-138
RC20BF103K
RC20BF224K

Symbol Description

R36	Potentiometer, 25K, DC balance ch. A
R37, 38	Composition, 220K
R39	Potentiometer, 25K, DC balance ch. B
R40	Composition, 220K
R41	Composition, 2.2K
R42, 43	Composition, 47K
R44, 45	Composition, 2.2K
R46, 47	Composition, 47K
R48	Composition, 2.2K
R49	Wirewound, 4K; 5W.
R50, 51	Wirewound, 7.5K; 7W.
R52, 53	Wirewound, 10, 5%; 2W.
R54, 55	Composition, 3.9K
R56, 57	Composition, 12K
R58	Wirewound, .47, 5W.
R59	Composition, 1K
R60	Wirewound, .47, 5W.

MISCELLANEOUS

CR1	Silicon Rectifier	SR782-117
F1	Fuse, 3.2A, slo-blo	F3319
T1	Transformer power	T782-115
T2	Transformer output	T782-116-1
T3	Transformer output	T782-116-2

Part Number

R50103-2

RC20BF224K

R50103-2

RC20BF224K

RC20BF222K

RC20BF473K

RC20BF222K

RC20BF473K

RC20BF222K

R692-130

R740-138

R782-120

RC20BF392K

RC20BF123K

R729-146

RC20BF102K

R729-146

TUBE LAYOUT

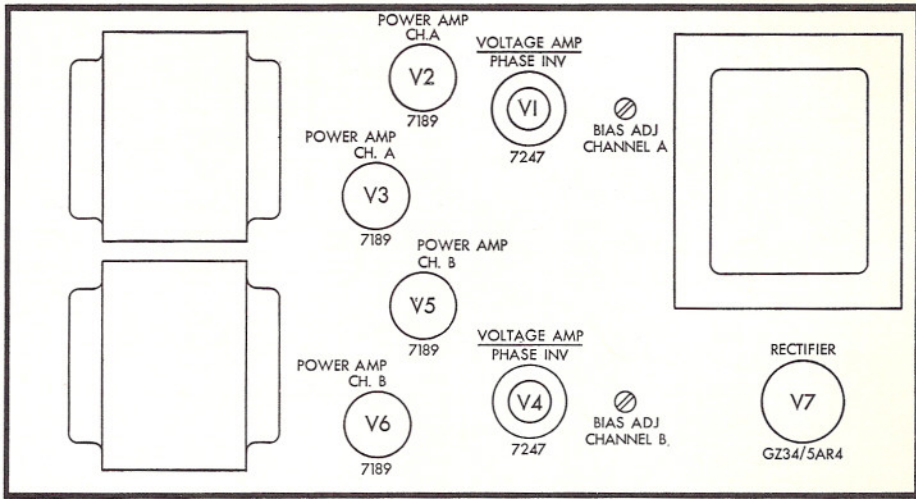

AW 1675

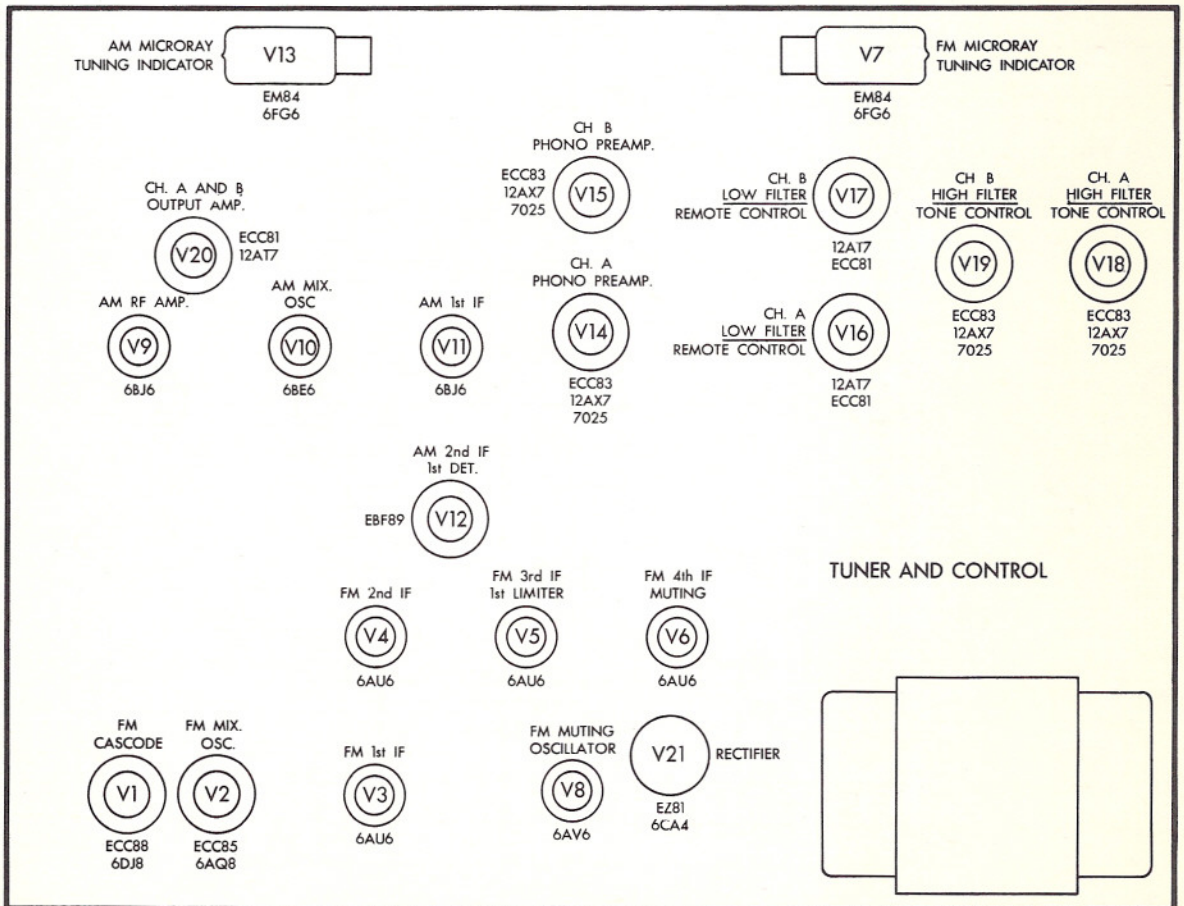

AW 1669

SCHEMATIC DIAGRAM · SPEAKER SYSTEMS

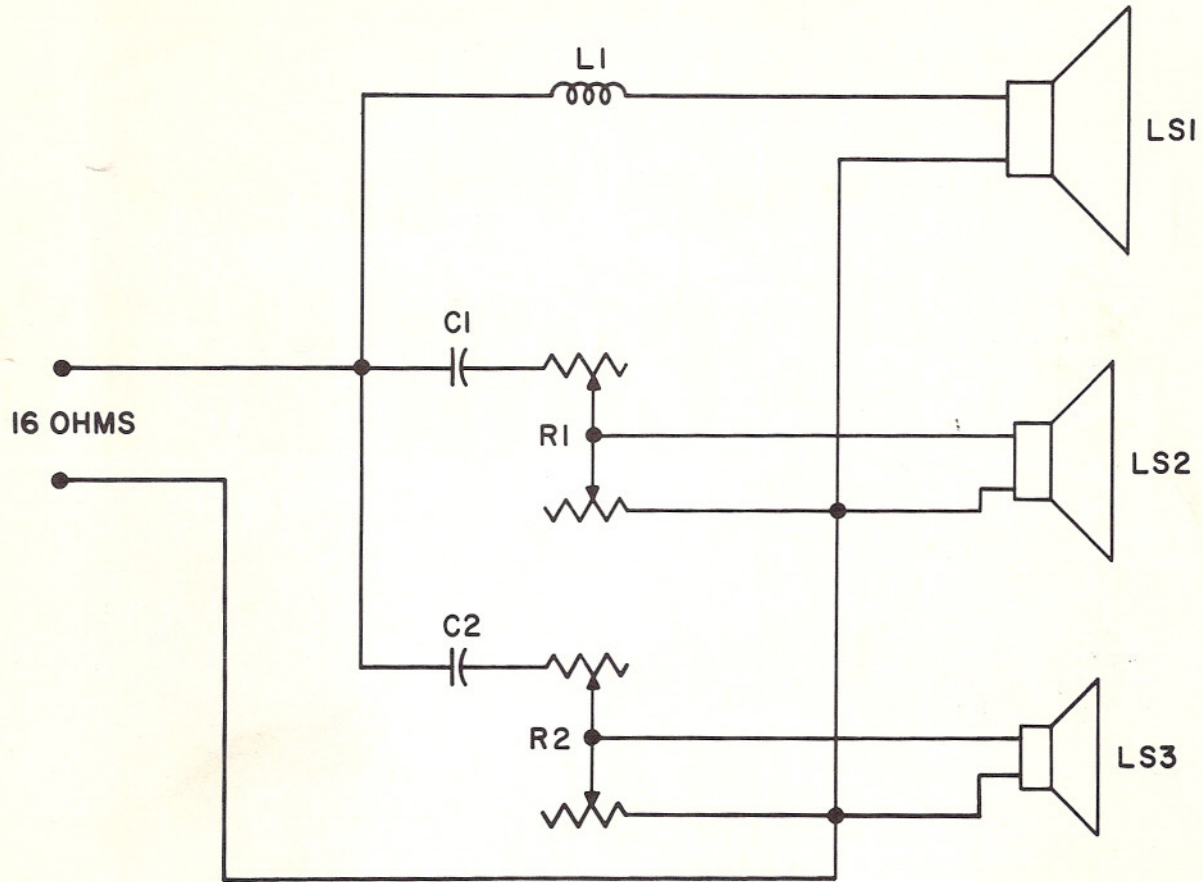

AW1835

PARTS DESCRIPTION LIST · SPEAKER SYSTEMS

Symbol	Description	Part No.
C1	Paper, 2uf, 50V	C547-118
C2	Mylar, 0.47uf, 250V	C50197-56
L1	Coil, 1.5 mh	L832-108
LS1	Speaker, Woofer, 16 ohms	LS832-105
LS2	Speaker, Mid-range, 16 ohms	LS832-106
LS3	Speaker, Horn tweeter, 16 ohms	LS832-107
R1, 2	L-pad, 16 ohms	M211



FISHER RADIO CORPORATION · NEW YORK