

MODELS 356-1,
356-27, 357-1

Model 356-1

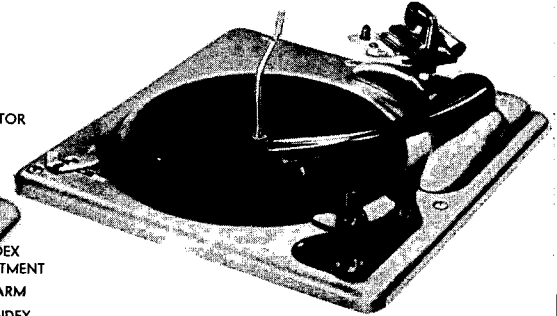

Model 356-27

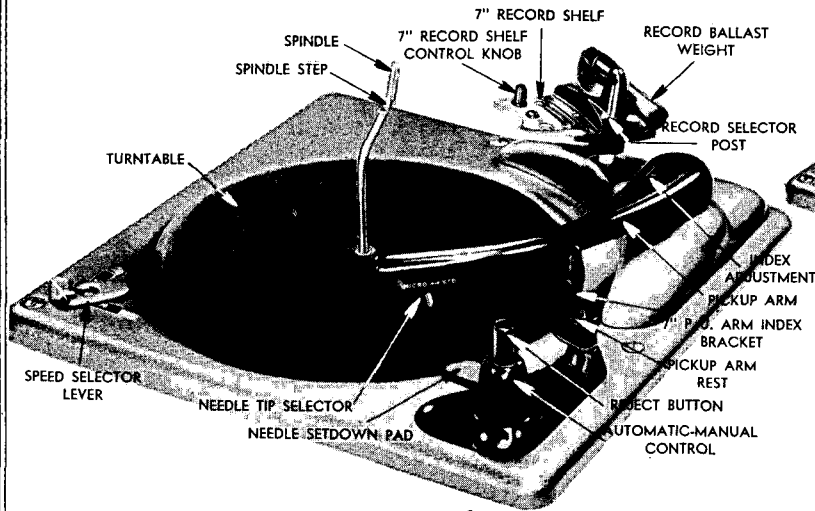
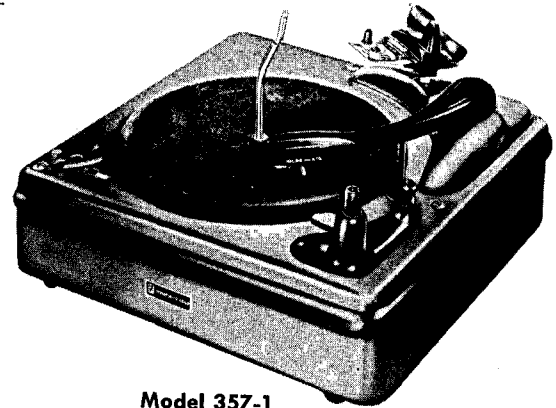

Model 357-1

DESCRIPTION

The Webster-Chicago Model 356-1 basic mechanism is a three speed, single post, spring cushioned spindle, automatic record changer. Simple in design and operation it provides automatic playing of up to a 1" stack of 7", 10" or 12" records at speeds of 33 $\frac{1}{3}$, 45 or 78 rpm.

Model 356 returns the pickup arm to the rest position after playing the last 10" or 12" record, although the motor continues to revolve until the Speed Selector Lever is moved to the nearest "OFF" position. Two "OFF" positions are available for ease of operation. The idler wheel is also pulled away from the motor shaft when the Speed Control Lever is in an "OFF" position, eliminating the possibility of a flat spot developing on the rubber wheel.

The last 7" record of a stack continues to play until the Speed Selector Lever is moved to one of the "OFF" positions and the Pickup Arm moved from the record to the Rest Position.

Automatic playing of 7" records is made possible by a simple, ingenious 7" record shelf which is easily placed on the Record Selector Post and by a movable 7" Pickup Arm Rest which can be swung into or out of position.

Model 356 also features the exclusive Webster-Chicago Velocity-Trip Mechanism. The pickup arm is not actuated by "lead-in" springs and there is a minimum of lateral pressure. The arm travels freely in either direction. This lack of lateral pressure or inertia adds immeasurably to the life of records and is considered to be as important as extra-light vertical pressure. The free-floating arm permits "home recordings" or "inside out" records up to 12" size to be played manually.

Model 356 will change warped or rough-edged records, at the same time assuring maximum protection to the finest discs.

Model 356-27 is the same as Model 356-1 except for the pickup arm. The special pickup arm on this model is provided with two interchangeable plug-in Heads in which the General Electric Variable Reluctance Cartridges can be mounted. The Brown head and the brass weight are for use with the RPX-040 General Electric Cartridge. The Red head is for use with the RPX-041 General Electric Cartridge. Use the RPX-041 for the 33 $\frac{1}{3}$ rpm and 45 rpm records.

Model 357 is a Model 356 mounted on an attractive metal base.

These service instructions apply to all three models.

PICKUP CARTRIDGE

The special pickup cartridge of Model 356-1 and Model 357 has a replaceable Tandem-Tip Needle. The lever on the cartridge is moved to "Std" or "Micro", as indicated on the pickup arm, to lower the proper point into playing position. All 78 rpm and some 33 $\frac{1}{3}$ rpm records including "Books for the Blind", require the "Standard" point. The 33 $\frac{1}{3}$ rpm Microgroove and 45 rpm records require the "Micro" point.

The special cartridge has been designed to play 78 rpm as well as 45 rpm and 33 $\frac{1}{3}$ rpm records at very light needle pressures.

Model 356-27 uses the General Electric cartridges as previously explained in the Description.

MODELS 356-1,
356-27, 357-1

OPERATION

MOTOR

Connect the motor cord to a source of 105-120 volt 60-cycle current only. If it is desired to operate the changer on 50-cycle current, a special motor shaft sleeve must be used in order to drive the turntable at the required speed.

Do not under any circumstances connect the motor to a source of direct current (DC) or alternating current of any other frequencies. The motor switch is part of the Speed Control Lever. The power is off when the lever is in an "OFF" position.

FOR AUTOMATIC RECORD CHANGE

1. Move the Tandem Tip Needle Selector to "Std" or "Micro" or plug-in the correct Head as explained in the description of the pickup cartridge above.
2. Turn the Record Selector Post to "10" or "12" for the ten- or twelve-inch records. The Record Selector Post is pivoted and turns in a counter-clockwise direction to the 10" position as indicated by the arrows. Do not use the Ballast Weight (see Illustration, Page 1) as a handle to turn the post. Turn by grasping the head of Record Selector Post with the thumb and forefingers. For 7" records, turn the Record Selector Post to "10". Move the pickup arm toward the center of the record until it touches the spindle. Move the 7" pickup arm rest into position and return the pickup arm to the 7" rest position. Place the 7" record shelf on the record selector post, as illustrated, with the control knob of the record shelf turned to "45" or "33" as required.
3. Turn the Manual-Automatic Switch (sleeve of Reject button) to AUTOMATIC.
4. With the Record Ballast Weight turned back, place up to a 1" stack of records on the spindle so that the bottom record rests on the step of the spindle and the shelf of the Record Selector Post or 7" Record Shelf.
5. Turn the Record Ballast Weight forward to rest on the top record or the 7" adapter.
6. Move the Speed Selector Lever to "33 $\frac{1}{3}$ ", "45" or "78", as required by the record being played. This also turns the power on.
7. Press the Reject button to start the changer.

To reject any record while playing in the AUTOMATIC position, press the Reject button.

NOTE: After the last record has been played, the Pickup Arm should not be touched until it has come to rest on the "Rest" button or has dropped to a normal playing position on the record.

8. After the last record has been played, the entire stack may be removed from the turntable at one time. The simplest procedure is as follows:
 - a. Turn the Record Ballast Weight back out of position.
 - b. Place the fingers of both hands under opposite edges of the bottom record.
 - c. Do not apply pressure to the top record. (Keep your thumbs free.)
 - d. Lift the stack of records straight up, following the contours of the spindle. This permits the stack of records to follow the curve of the spindle without binding and greatly facilitates the removal of the stack.

FOR "MANUAL" RECORD CHANGE

1. Turn the Record Selector Post to the "12" position. (This is not essential but permits more clearance in loading and unloading records.)
2. Turn the Selector Switch (sleeve of Reject Button) to MANUAL.
3. Place a record on the turntable. It may facilitate this operation if 10" and 12" records are placed over the spindle at an angle, with one edge of the records held below the level of the Record Selector Post Shelf. Records may be removed in the same manner.
4. Move the Speed Selector Lever to the proper position as required by the record being played.
5. Move the Tandem-Tip Selector to "Std" or "Micro" as explained in the description of the pickup cartridge.
6. Place the needle gently on the edge of the record. Do not lift the pickup arm too high as this will cause it to catch in the Automatic Stop Lock position.
7. To stop the mechanism at any time, turn the Speed Selector Lever to an "OFF" position.

SERVICE INFORMATION AND ADJUSTMENTS

All units are accurately adjusted, lubricated and tested at the factory. However service repairs and adjustments sometimes become necessary. This bulletin should be studied carefully before making any adjustments or replacing parts.

Service parts are available from your Webster-Chicago distributor. All parts must be ordered by piece part number and also record changer model and production number, stamped on the under side of the main plate.

The functions and most probable misadjustments of the main assemblies are as follows (reference numbers refer to the exploded view on pages 12 and 14):

THE AUTOMATIC TRIP FAILS TO FUNCTION

The Main Cam Assembly (38) and Actuating Gear (36) are the heart of the record changer. The Main Cam Assembly drives the mechanisms associated with the action of the Pickup Arm (5) and the Record Selector assemblies. It, in turn, is driven by the gear train (29, 30, 31) and the Turntable which is rim driven by the phonograph motor.

The Main Cam Assembly and Actuating Gear is put in motion or "tripped" by means of the "automatic" trip or by the manually operated "reject" trip. When the movement of the Pickup Arm toward the spindle is greater than $\frac{1}{8}$ " in $\frac{1}{2}$ revolution of the Turntable, the Automatic Trip Arm (33) trips the Velocity Trip and Roller Assembly (37). This releases the Actuating Pawl on the Main Cam Assembly (38), allowing it to engage the Main Cam Actuating Gear (36) and driving it through the change cycle. The pressure from the Automatic Trip Arm required to actuate the trip mechanism is negligible.

The Automatic Trip Arm (33) follows the movement of the Pickup Arm through a weighted friction clutch (32). This clutch must be kept free of oil and grease. Should it become necessary,

clean the clutch parts with carbon tetrachloride. This clutch should operate the trip mechanism without placing undue drag on the movement of the pickup arm.

Also check for:

1. Velocity Trip and Roller Assembly binding.
2. Slight burr on end of the actuating pawl or on the underside of the Velocity Trip hook.
3. Actuating Pawl stuck (part of Main Cam Assembly (38) engaged by the hook end of the Velocity Trip and Roller Assembly (37).
4. Automatic Trip Arm (33) bent and not hitting the Velocity Trip and Roller Assembly (37).
5. Automatic Trip Arm (33) fails to touch the Velocity Trip and Roller Assembly.
6. Velocity Trip and Roller Assembly (37) rubbing on the underside of the Main Cam Actuating Gear (36).
7. No velocity lead-in groove or eccentric groove in the center of record.
8. Foreign matter in record groove.
9. Badly worn record.
10. Badly bent or worn needle.

IF THE "REJECT" TRIP FAILS TO FUNCTION

When the "On" button is pressed, the hair spring of the "reject" trip lever arm (65), actuates the Velocity Trip and Arm Assembly, putting the change mechanism in cycle.

Check for:

1. "Reject" trip hair spring of Lever (65) bent or broken.
2. Velocity Trip and Roller Assembly (37) binding.
3. Actuating Pawl (part of Main Cam Assembly 38) stuck.

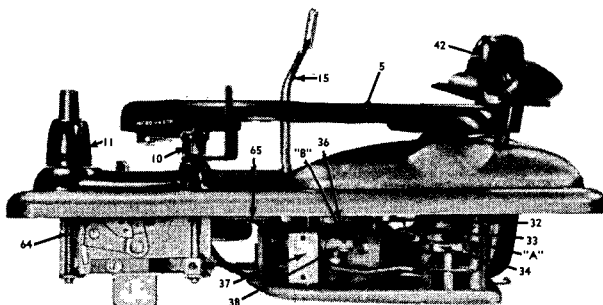

Fig. 1

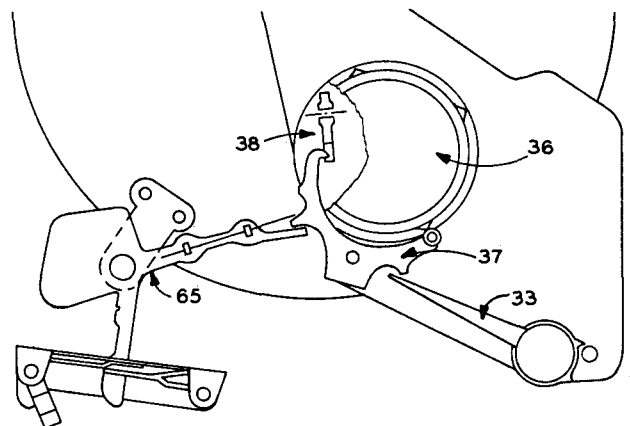

Fig. 2

MODELS 356-1,
356-27, 357-1

IF THE MECHANISM CONTINUES TO CYCLE

At the completion of the change cycle, the Actuating Pawl is disengaged from the Main Cam Assembly Actuating Gear (36) by the hook end of the Velocity Trip and Roller Assembly (37) which has been returned to its normal position by the reset points on the Main Cam Drive Gear (Fig. 3). This hook should be adjusted for about $\frac{1}{16}$ " clearance from the bottom of the Main Cam Drive Gear (36), Fig. 1. Greater clearance may permit the pawl to bounce past the hook and re-engage, causing the mechanism to continue to cycle.

If the clearance between the lip on the Velocity Trip Lever and the edge of the Main Cam is too small, it will prevent the hook end of the Velocity Trip Lever from engaging the trigger. Adjust the clearance between the lip (D, Figs. 3 and 5) on the Velocity Trip Lever of the Main Cam to be within $\frac{1}{16}$ " when the roller is contacting the point of one of the protrusions on the Actuating Gear.

Also check for:

1. Velocity Trip and Roller Assembly (37) rubbing on Main Cam Actuating Gear (36).
2. Manual Trip Lever (65) binding.
3. "Disengage Roller" broken on Velocity Trip and Roller Assembly (37).

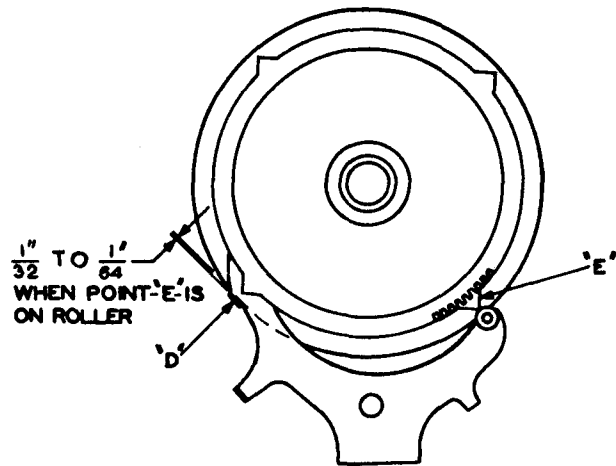

ADJUST IF NECESSARY BY BENDING AT POINT "D".

Fig. 3

PICKUP ARM LIFT TOO HIGH OR TOO LOW

The vertical movement of the pickup arm is controlled by the angle of the Pickup Arm Raising Lever (40), Fig. 4. The needle should approach the top record of a full stack of 10" records on the turntable with approximately $\frac{1}{16}$ " clearance. To adjust:

1. Put a full stack of 10" records ON THE TURN-TABLE.
2. Press the "On" button and rotate the Turntable clockwise until the needle clears the top record of the stack by about $\frac{1}{16}$ ".

3. Be sure the notch in the Pickup Arm raising disc (34) engages the pickup arm raising lever (40).
4. If the needle does not clear the top record or if it raises too high, adjust by bending the pickup arm raising lever at the point indicated in Fig. 4 Y.

CAUTION: All adjusting bends should be made slowly, using slight but firm, easy pressure.

Be sure the set screws (A of Fig. 1) of the pickup arm raising disc are not loose and are properly positioned in the alignment holes as explained in the paragraph on Needle Setdown Indexing.

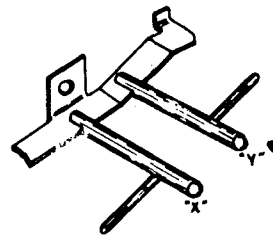
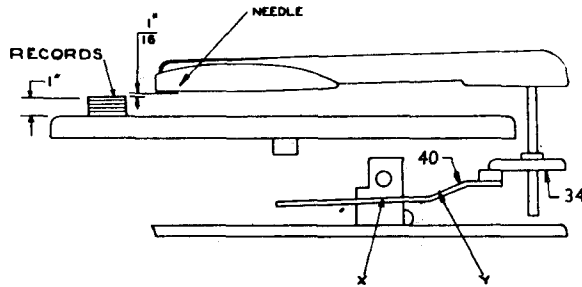

Fig. 4

NEEDLE SET DOWN INDEXING INCORRECT

The horizontal movement of the pickup arm (5) is controlled by the eccentric excursion of the Pickup Arm Raising Lever (40) moving the Pickup Arm Raising Disc (34) when actuated by the Main Cam Assembly (38). The eccentric screw (part of 6), accessible through the top of the pickup arm (5), should take care of any normal position adjustment. Turn this screw clockwise to index the needle in toward the spindle and counter-clockwise to index the needle out away from the spindle.

Should further adjustment be necessary, proceed as follows:

1. Set the eccentric screw, just mentioned, to a middle position.
2. Set the Record Selector Post (42) to the 10" position.
3. Operate the mechanism by revolving the Turntable manually until the needle drops to within $\frac{1}{8}$ " of a 10" record on the turntable.
4. Be sure the notch in the Pickup Arm Raising Disc (34) engages the Pickup Arm Raising Lever (40).

MODELS 356-1,
356-27, 357-1

5. With a No. 8 Bristol wrench in each of the set screws of the Pickup Arm Raising Disc (35) as indicated in A, Fig. 1, alternately loosen one screw and tighten the other until the needle rests above the record lead-in groove at the desired point.
6. Complete the change cycle of the mechanism and position the Pickup Arm on the rest button (10). If necessary, bend the tongue of the Pickup Arm Raising Disc closer to or away from the Base Plate Post until the Pickup Arm is correctly seated on the rest button when the tongue is touching the Base Plate Post.

NOTE: All adjusting bends should be slight but firm, easy bends.

CHANGE CYCLE STARTS BEFORE END OF RECORD

If the trip assembly chatters while the changer is running, or if the changer cycles before the entire record is played, there is probably insufficient clearance between the hook end of the Velocity Trip and Roller Assembly (37) and the Actuating Gear (36). This clearance should be adjusted to be within $\frac{1}{32}$ " to $\frac{1}{64}$ " by bending the lever at point "C" shown in Fig. 5.

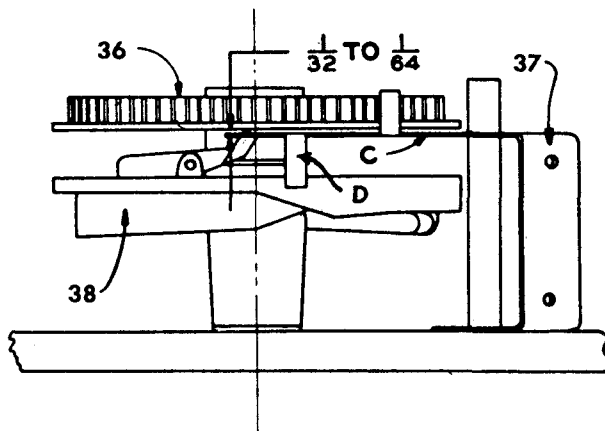

Fig. 5

MORE THAN ONE RECORD IS DROPPED DURING A CHANGE CYCLE

The floating latch at the top of the Record Spindle is so spaced that only one record at a time can slide between the heel of the latch and the step of the spindle. The hole in the latch is elongated so that the latch can slip into the spindle recess when records are being removed.

If more than one record is dropped at a time, it will be found to be due to:

1. Foreign matter in spindle recess causing the latch to stick.
2. Exceptionally thin records.

RECORD DROPS ON PICKUP ARM

As the change cycle is started, the first motion of the inclined outer bottom surface of the Main Cam (38) causes the Record Selector Post (42) to move toward the Spindle about $\frac{3}{32}$ inch. This position is maintained until the Pickup Arm has made its full outward lateral excursion at which time the Record Selector Post again moves toward the spindle, causing the bottom record to drop into playing position.

If the Record Selector Post (42) has been bent back, away from the Record Spindle, it is possible for a standard record to rest on the spindle step with its edge just over the edge of the Record Selector Post shelf. Then as the change cycle is started, the record is pushed off the spindle by the initial movement of the Record Selector Post, so that it drops on the Pickup Arm.

To correct this condition, the Rocker Arm Assembly must be adjusted so that the Record Selector Post is brought nearer to the spindle. This adjustment is made in the following manner:

1. With the mechanism at rest, remove the Turntable and replace the Record Spindle. Set the Record Selector Post to the position for playing 12-inch records and place a 12-inch record on the Record Spindle.
2. Insert a short screwdriver through the motor-board opening into the screw slot as shown at "A" in Fig. 6. Clockwise rotation of the screw will increase the distance between the Record Spindle and the Record Selector Post; counter-clockwise rotation will decrease it.

It is recommended that the distance between the edge of the record and the step of the Record Selector Post be held to just over $\frac{1}{32}$ of an inch so that records with rough or sharply beveled edges will not catch on the outer edge of the Record Selector Post.

CAUTION: Be certain that a standard size record is used in making this adjustment. A standard 10" record measures $9\frac{7}{8}$ " \pm $\frac{1}{32}$ " diameter. A standard 12" record measures $11\frac{7}{8}$ " \pm $\frac{1}{32}$ " diameter.

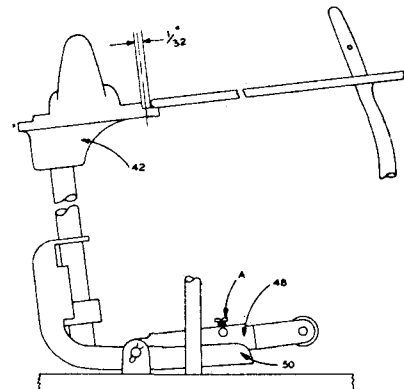

Fig. 6

MODELS 356-1,
356-27, 357-1

PUSH OFF POST ANGLE INCORRECT

The Record Selector Post should be adjusted so that the curve of the shelf matches the curve of the record. See Fig. 7.

To adjust this angle:

1. Turn the Record Selector Post to the "10" position.
2. Place a ten-inch record on the Spindle in the normal position for automatic playing.
3. With a No. 8 Bristol wrench in each of the set screws (point A, Fig. 7), alternately loosen one and tighten the other until the Record Selector post angle is correct. Be sure that both set screws are tight at the completion of this adjustment.

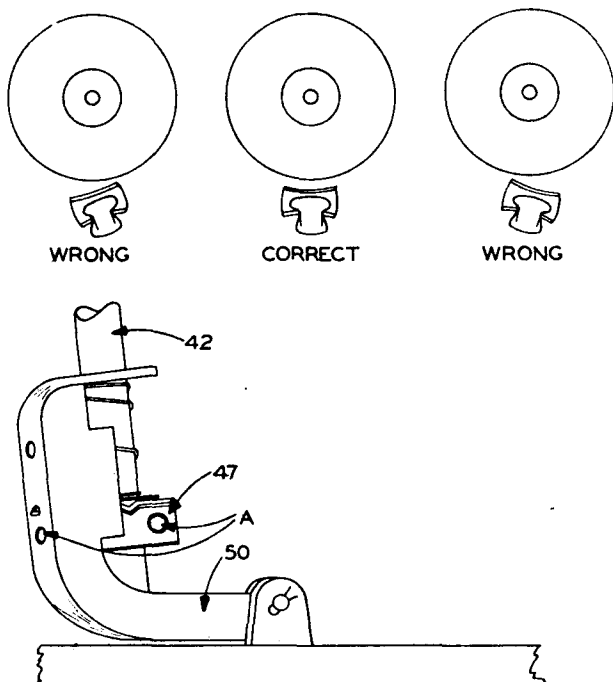

Fig. 7

ERRATIC INDEXING

Indexing in the 10" or the 12" position is controlled through the presence or absence of pressure from the Compression Spring (47A) on the Pickup Arm Raising Lever (40). The compression on this spring is changed as the Record Selector Post (42) is changed to the 10" or 12" position. Improper adjustment of the spring tension will result in erratic indexing. In the 12" position, the spring should be just free. In the 10" position, the compression of the spring holds the stud of the Pickup Arm Raising Lever (40) against the outside edge of the groove, forcing the stud to travel the inside edge or the outside edge of the groove in the bottom of the Main Cam (38).

To adjust:

Bend the slotted arm (part of 40) for proper tension and smooth clearance of the spring guide arm (47).

LAST RECORD DOES NOT PLAY

The weight of the records on the Spindle keeps the Automatic Shut Off Lock Lever (44) from dropping and engaging the Pickup Arm Raising Disc (38), thus permitting the mechanism to continue to cycle.

The Push Off Post (50) moves forward slightly at the beginning of each change cycle. The bracket "B" on this post is then underneath the elevated hook "A" on the Automatic Shut Off Lock Lever (44). This forward movement takes place before the last record drops so the change cycle should continue. However the dropping of the last record releases the Automatic Shut Off Lock Lever, permitting it to drop and shut off the mechanism when the change cycle starts after the last record.

If the last record does not play:

1. Bend the elevated hook "A", Fig. 8 forward so that it will overlap the Push Off Post bracket "H" about $\frac{1}{32}$ " with a record on the spindle.

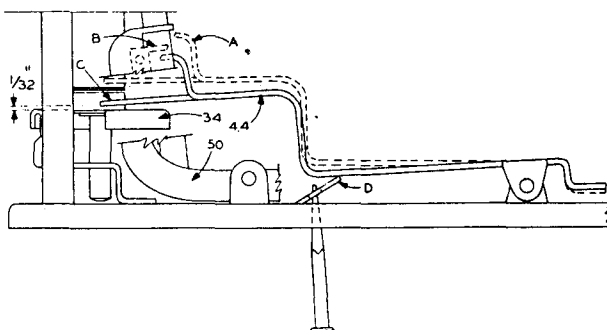

Fig. 8

LAST RECORD CONTINUES TO PLAY (10" or 12" Records)

1. Check the record spindle to be sure that it moves up and down freely.
2. With no records on the spindle, check the Automatic Shut Off Lock Lever (44). The lower hook end of this arm "C" should catch the Pickup Arm Raising Disc (34) at the beginning of the cycle to prevent travel of the Pickup Arm, causing it to drop on the OFF button. With no records on the Spindle and with the mechanism at rest, this hook should clear the top of the Pickup Arm Raising Disc by $\frac{1}{32}$ ". Adjust if necessary, by inserting a screw driver in the hole in the bottom base plate and bending lip "D". Never attempt to move the Pickup Arm Raising Disc up or down.
3. The elevated hook "A" on the Automatic Shut Off Lock Lever will sometimes lock with the bracket "B" on the Record Selector Post (50) if the drop of the record is delayed. More clearance can be obtained by bending the elevated hook "A" away from the bracket.

GLIDE-IN ON 12" RECORDS

The term "glide-in" is used to describe the action of the pickup arm and needle when the needle does not sit down smoothly in the first groove of the record, despite accurate indexing adjustments, but seems to glide over the first two or three grooves before seating itself properly. If glide-in occurs:

1. Check tension of compression spring (47A). The spring should be free in 12" position at the moment the needle sets down on the record.
2. Remove any cause of friction in index lever (47) by bending the "eye" of 40.
3. On Model 357, pulling the metal base up snug to the main plate may put too much tension on the compression spring (47A). Be certain spring (47A) is very free.
4. The pickup cord may be dressed too tight or in such a manner that it interferes with the free movement of the pickup arm. Make certain there is sufficient play in the pickup cord.

SLIDE-IN OR NEEDLE JUMPS GROOVES

Slide-in describes the condition where the needle will touch the first groove of the record properly but will jump the grooves forward or back as though the needle pressure was too light.

To correct slide-in, check for:

1. Incorrect needle tip. The standard tip will be especially likely to jump grooves of a micro-groove record. Be certain the "micro" tip is used for either the 33 $\frac{1}{3}$ or 45 rpm microgroove records.
2. Chipped or damaged needle.
3. Tight pickup cord.

CHANGE CYCLE STARTS WHEN NEEDLE TOUCHES RECORD (10" or 7" Records)

1. The velocity trip arm (33) may be too close to lip "B" of velocity trip (37) at the instant of contact of the needle with the record. There should be at least $\frac{1}{64}$ " clearance between the velocity trip arm and the velocity trip. Carefully bend lip "B" in to provide proper clearance. However, do not in any way bend the velocity trip at any other point. Improper bending may cause binding and constant tripping of the mechanism.

TO ADJUST SPEED SELECTOR LEVER POSITION

1. Loosen set screw of coupling (62).
2. Move Idler assembly (67) to 45 rpm position.
3. With the Speed Selector Lever opening over "45", tighten the set screw.

INCORRECT TURNTABLE SPEED

The three speed mechanism and the motor are one assembly. The speed selector idlers (24, 26 and 27) are mounted on a moveable metal plate (67) in such a way that moving the Speed Selector Lever (70) moves the correct idler into position between the motor shaft and the Turntable drive idler (91). The tongue of the detent spring (73) fits into indentations in the edge of the metal plate to index the speed selector idlers and holds them firmly in the desired position.

"Off" indentations between each speed position hold the idlers away from the motor shaft and the Turntable idler when the Speed Selector Lever is in an "off" position.

If the Turntable speed is incorrect, check for:

1. Turntable idler (91) cocked at an angle. Bend the wheel and shaft to straighten wheel.
CAUTION: Do not bend idler (91) toward the speed selector idlers (24, 26, 27). Bend only sideways or away from the small idlers.
2. The idler mounting assembly (part of motor assembly 54) must not bind. There should be at least $\frac{1}{64}$ " play at point "A". Bend the raised metal stop if more clearance is needed.
3. The entire motor assembly (54 plus 67, etc.) should be free floating. There should be slight play of the Speed Control Lever (70) between the "78" and "33" positions and the stops at the end of the speed selector dial. If there is any binding, loosen set screw of coupling (62) and retighten with the tongue of the detent spring (73) in the proper position.

ERRATIC SPEED (WOW)

Remove any dirt or excess flocking from the inside rim of the turntable. Check the rubber idler wheel for a flat spot or "out of round".

If the rubber part of either Drive wheel becomes slick and shiny — Replace.

STALLS DURING CHANGE CYCLE

See Above.

REPLACEMENT OF PARTS TO REPLACE THE PICKUP ARM

1. Unhook the pickup arm hinge clip (6) and raise the arm to a vertical position.
2. Remove the two mounting screws. Remove the pickup arm.
3. Attach the new arm.

The weight of the arms is uniform so the needle pressure adjustments should be left alone.

REPLACE PICKUP ARM BRACKET AND SHAFT ASSEMBLY

1. Loosen Bristol screws in Pickup Arm Raising Disc (34).
2. Remove Disc washer (43), Automatic Trip Arm (33) and Clutch (32) by sliding them off the bottom of the Pickup Arm Shaft (7) and pull shaft out of changer from above.

To replace, reverse the procedure and adjust the Pickup Arm Raising Disc for proper indexing as explained

TO REPLACE THE CARTRIDGE

1. Remove the two mounting screws, one on each side of the cartridge, and carefully remove pickup cord tips from cartridge pins.
2. Remove the old cartridge and replace with the new one.

Be certain the cartridge is parallel with the side of the pickup arm.

TO REPLACE THE NEEDLE

1. Loosen the needle set screw, using a small screw driver.
2. Remove the needle.
3. Insert the new needle with the flat side of the needle toward the set screw. Be sure the needle shank is all the way in to the bottom of the needle hole.
4. Tighten the set screw. The needle point should be parallel to the sides of the needle slot and evenly spaced between the walls of the slot.

REPLACE RECORD POST AND ROCKER ARM ASSEMBLY

1. Remove the Pickup Arm Assembly.
2. Remove the four nuts under the main plate which hold the Crescent Assembly.

3. Unhook the Rocker Arm Return Spring.
4. Remove the Rocker Arm Pivot Pin.
5. Lift out the Record Selector Post, Rocker Arm and Crescent Assembly as a unit.
6. In replacing the Rocker Arm Assembly, note paragraph "Replacing the Sub-Plate Assembly".

TO REPLACE THE MOTOR

It is not necessary to replace the entire Three Speed mechanism when replacing the motor. However, it is necessary to remove the entire assembly from the main plate and then remove the motor from the assembly.

1. Remove the entire assembly by removing mounting screws (58) and retaining clip (23).
2. Remove the Turntable Drive Wheel (91), the detent spring (73) and tension spring (74).
3. Remove the Three Speed mechanism plate assembly (67). Do not remove the small idler wheels (24, 26, 27) from the plate.
4. Reassemble new motor to the Three Speed Mechanism plate and the entire assembly to the main plate.
5. It may be necessary to adjust the play of the Three Speed Mechanism mounting plate "C" (part of the motor 54), so there is proper play between the sliding stop and the metal stop at point "A". The mounting plate should be free, approximately $\frac{1}{64}$ " clearance between the sliding stop and point "A". The Speed Selector Lever (70) should be in the "78" position when making this adjustment. See paragraph 2 of "Incorrect Turntable Speed"

LUBRICATION

Webster-Chicago Record Changers leave the factory completely oiled and lubricated. Under normal conditions this should be sufficient for approximately one year or 1,000 hours of operation. When operated under extreme conditions of dust or heat, this operation should be performed more frequently as required.

Do not permit any oil or grease to get on the rubber Idler Drive Wheels or the Motor Sleeve, on Turntable Drive Rim or on the Automatic Trip Arm clutch. Any oil or grease on these points should be removed using Carbon Tetrachloride. The recommended lubricants and points of lubrication are as follows:

A — No. 10 OIL (Apply With Small Oil Can or Medicine Dropper)

1. Motor Bearings.
2. Pickup Arm Shaft. Drop one drop each to bottom bearing point, bracket hole through Main Base Plate.
3. Ball Bearing Assembly.
4. Idler Wheel Felt.

B — A Non Fluid Lubricant (Apply With Small Brush)

1. Idler Wheel Link.
2. Turntable Shaft Stud.
3. Pickup Arm Hinge Pins.
4. Knife edge of Pickup Arm Raising Lever.
5. Main Cam Bearing. (It is necessary to remove the sub-plate assembly to lubricate this bearing.)
6. Teeth of Main Cam Actuating Gear.
7. Track of Main Cam Gear.
8. Teeth of Large and Small idler gears.
9. Raising lever Bracket bearing surfaces.

AVOID EXCESSIVE LUBRICATION

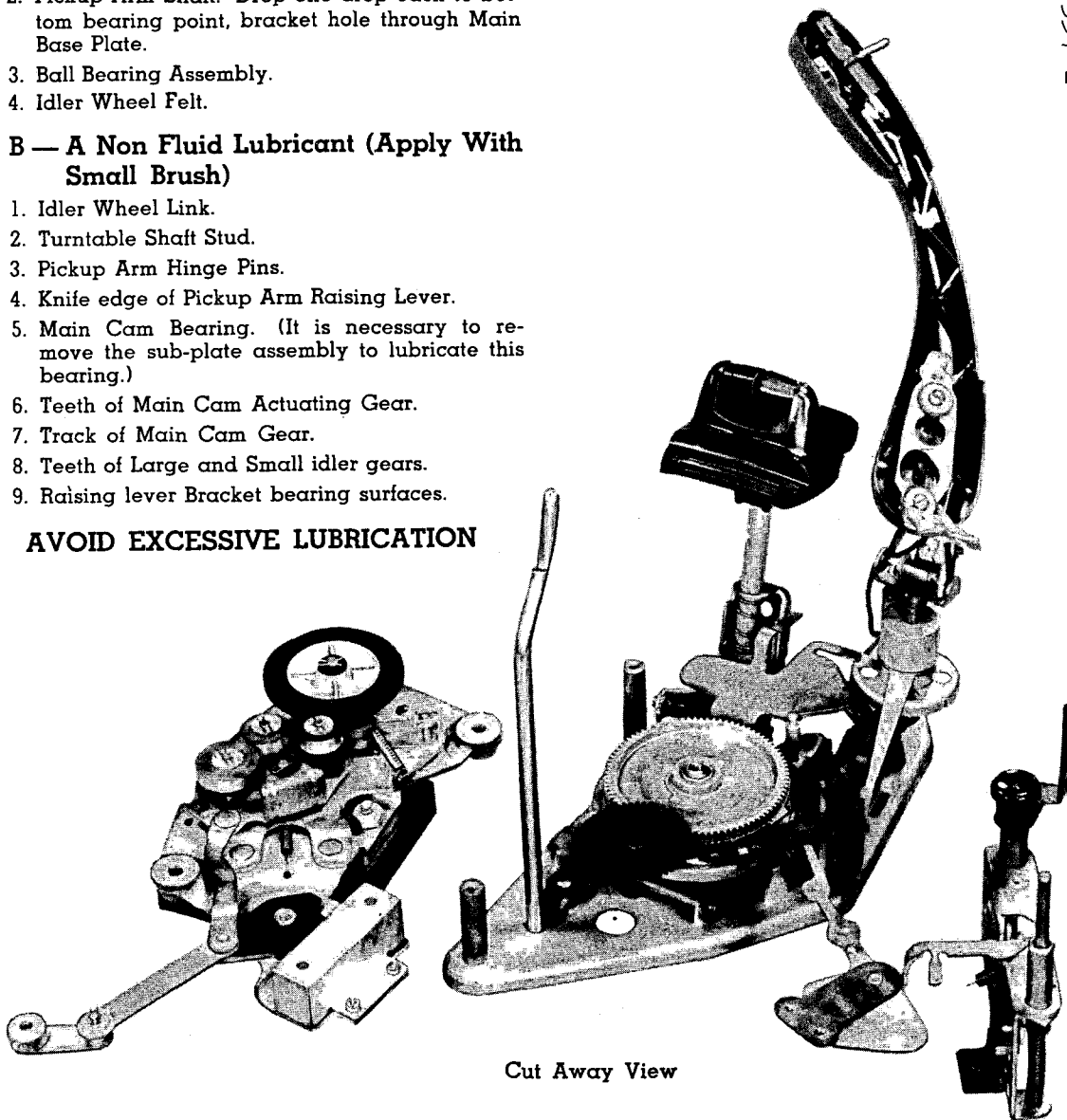

Cut Away View

MODELS 356-1,
356-27, 357-1

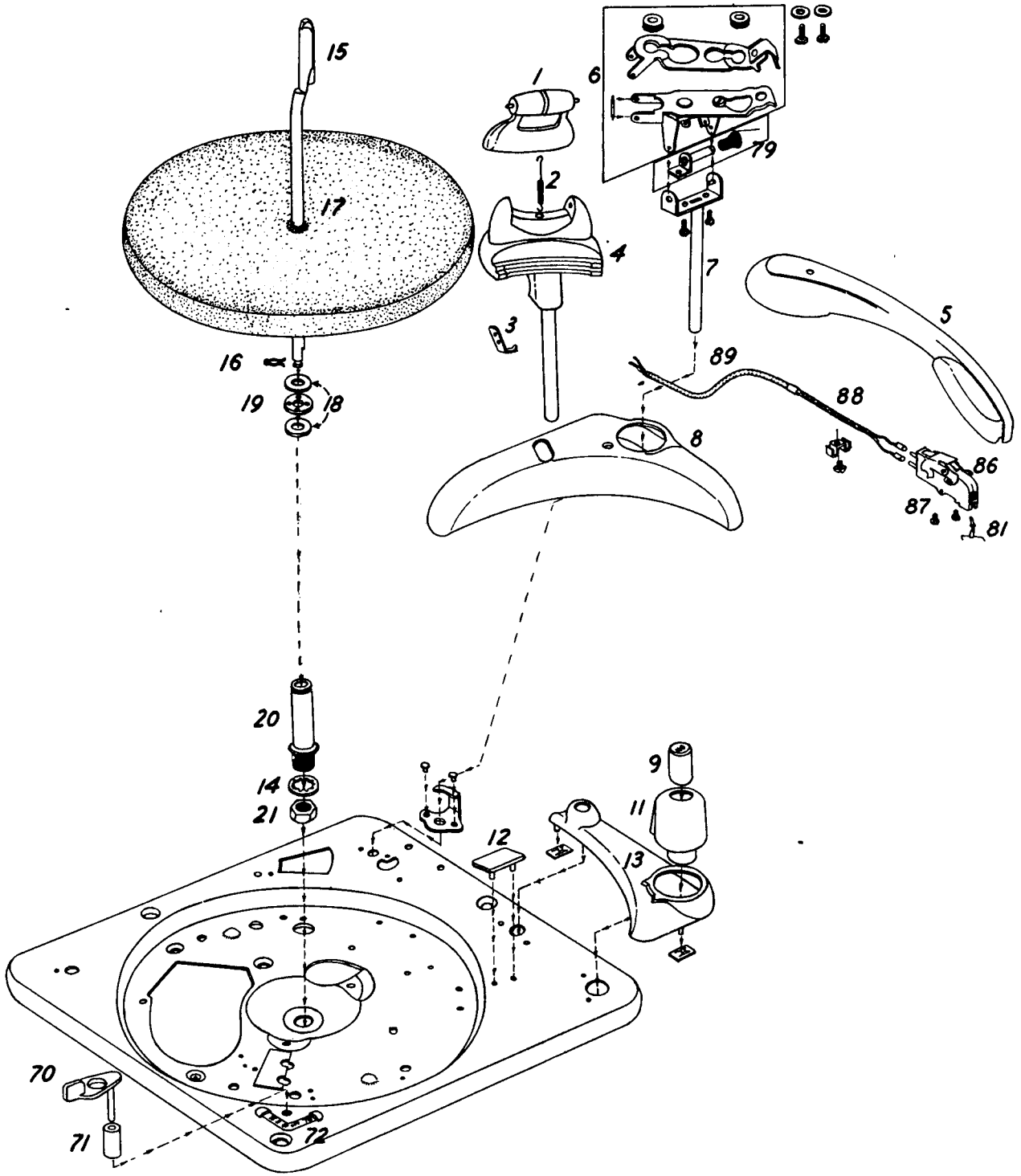

Exploded View above Main Plate

MODELS 356-1,
356-27, 357-1

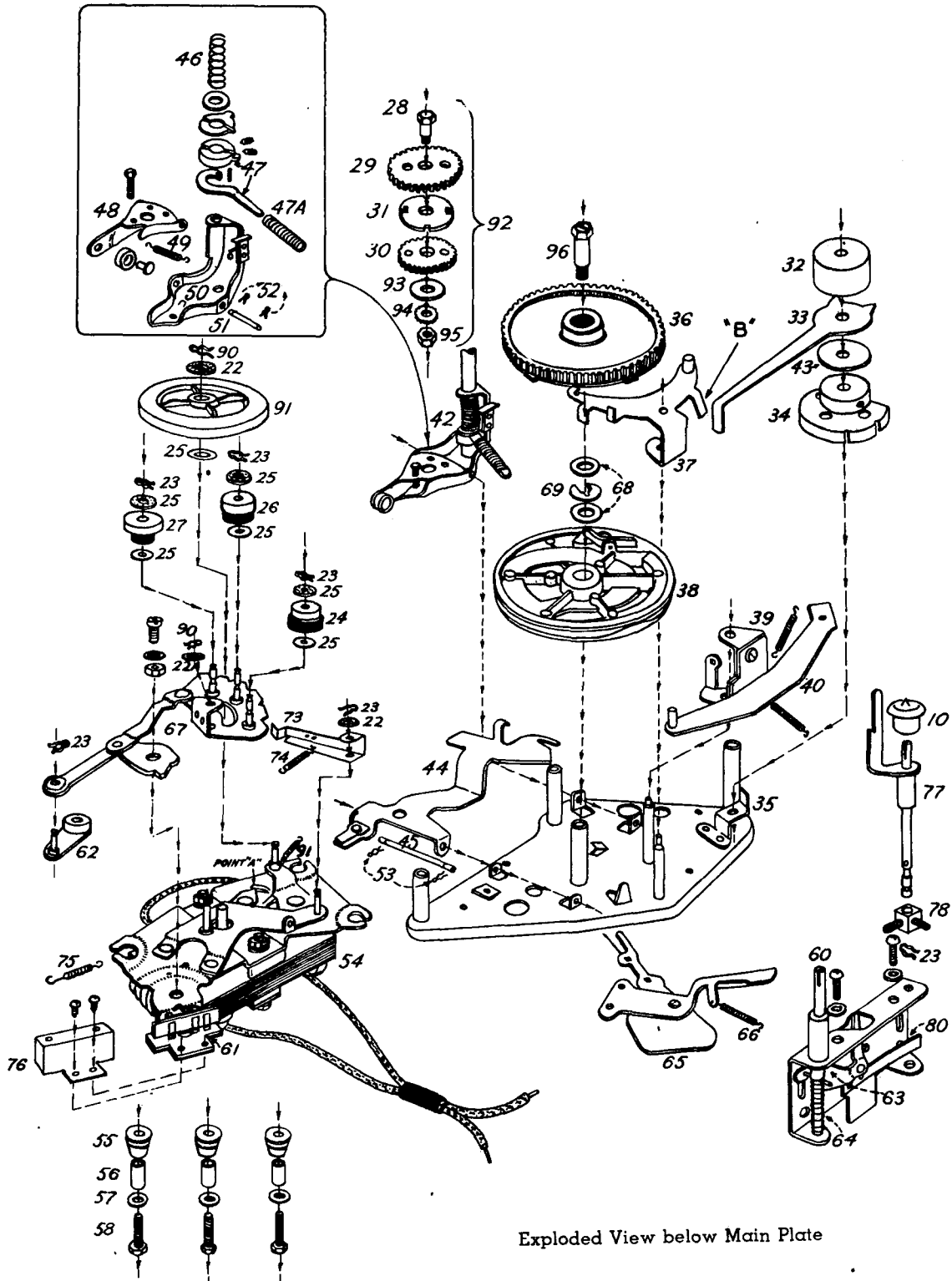

PARTS LIST

Illustration No.	Part No.	Description
1	49X074	Record Stabilizer
2	46P126	Tension Spring
3	45P464	Spring Retainer

PARTS LIST

Illustration No.	Part No.	Description
4	49X029	Selector Post
5	49X124-1C	Pickup Arm
6	21X283	Pickup Arm Mounting Hinge
7	11X385	Pickup Shaft Assembly
8	45P350	Crescent Plate
9	49P111	Reject Button
10	49P125	Pickup Arm Rest
11	11X139	Control Knob and Set Screw
12	24P022	Needle Pad
13	49P027	Escutcheon
14	25P333	Lock Washer
15	11X133	Spindle
17	11X289	Turntable
18	25P269	Washer Bearing Race
19	11X058	Bearing Race Assembly
20	41P414	Turntable Bearing
21	26P687	Bearing Nut
70	42X205	Speed Selector
71	41P669	Bushing
72	78P454	Speed Indicator
87	26P474	Screw — Cartridge Mounting
16	50P204	Spindle Clip
22	25P407	Felt Washer
22A	25P030	Felt Washer
23	50P034	Clip
24	11X456	Drive Wheel — 33½
25	25P046	Fibre Disc
26	11X458	Drive Wheel — 45
27	11X460	Drive Wheel — 78
28	41P333	Shoulder Screw
29	47P024	Large Fibre Gear
30	47P023	Small Fibre Gear

Illustration No.
31
32
33
34
36
37
38
39
40
41
43
44
45
46
47
47A
48
49
50
51
52
53
54
55
56
57
58
59
60
61
62
63
64
65
66
67
68
69
73
74
75
76
77
78
79
80
88
89
90
91
92
93
94
95
96
97

Part No.
45P342
41P576
45P568
11X227
11X032
11X320
11X033
46P139
11X046
46P022
23P009
11X079
41P443
46P012
11X049
46P011
11X141
46P017
11X142
41P421
50P125
50P125
17X467
25P363
41P592
25P367
26P110
11X470
41P444
32P054
17X466
45P361
46P123
11X158
46P117
17X464
25P343
25P342
45P817
46P187
46P139
45P819
11X472
41P704
11X386
45P872
20X1264-4
20P811-60
50P125
11X366
11X132
25P284
25P222
26P046
26P748
46P134

Description
Idler Gear Coupler
Weight
Auto Trip Arm
Tone Arm Raising Disc
Trip Reset Gear
Velocity Trip
Cam and Trigger Assembly
Tension Spring — Index Plate
Raising Arm Lever
Tension Spring
Friction Disc
No-Record Lever
Pin
Compression Spring
Selector Lever and Collar
Compression Spring
Rocker and Roller Assembly
Compression Spring
Rocker Arm Lever
Retaining Pin
Clip
Clip
Motor and Top Bridge Assembly
Rubber Shock Motor Mount
Motor Mount Sleeve
Motor Mount Washer
Motor Mount Bolt
Automatic Manual Control Assembly
Switch Shaft
Switch
Hub and Lever Assembly
Switch Lever
Compression Spring
Trip Lever and Wire
Tension Spring — Trip Lever
Index Plate and Cam Assembly
Washer
"C" Washer
Index Lock Lever
Tension Spring — Lock Lever
Tension Spring — Index Plate
Switch Cover
7" Adapter Rest
Positioning Cam
Pickup Counter Balance
Leaf Spring
Pickup Cord — Internal
Pickup Cord — External
Clip
Idler Wheel
Idler Gear Assembly
Coupling Washer
Lock Washer
Nut
Shoulder Screw
Tension Spring — Idler Link