



Stereophonic

THE FISHER X-101-C

SERVICE

MANUAL



MODEL X-101-C

CHASSIS SERIAL NUMBERS
FROM 10001 TO 19999 INCLUSIVE

PRICE: \$1.00

FISHER RADIO CORPORATION • NEW YORK

PARTS DESCRIPTION LIST

CAPACITORS

10% tolerance for all fixed capacitors, unless otherwise noted or marked GMV (guaranteed minimum value). All capacitors not marked uf are pf (uuf).

Symbol	Description	Part No.
C1, 2	Ceramic, .01uf, 20%, 500V	C50089-3
C3, 4	Mylar, .022uf, 400V	C50197-28
C5, 6	Ceramic, 68, 1000V	C50070-12
C7, 8	Ceramic, 750, 1000V	C50072-37
C9, 10	Mylar, .022uf, 400V	C50197-28
C11	Ceramic, 82, 1000V	C50070-7
C12	Mylar, .047uf, 400V	C50197-30
C13	Ceramic, 68, 1000V	C50070-12
C14	Mylar, .022uf, 250V	C50197-49
C15	Mylar, .047uf, 400V	C50197-30
C16	Ceramic, 68, 1000V	C50070-12
C17	Mylar, .022uf, 250V	C50197-49
C18, 19	Ceramic, 47, 1000V	C50070-4
C20, 21	Mylar, .047uf, 400V	C50197-33
C22	Electrolytic, 100uf, 100V	C663-143
C23, 24	Mylar, .047uf, 400V	C50197-30
C25	Electrolytic, 200uf, 250V	C50180-20
C26	Electrolytic, 2 Section: A—200uf, 250V B—40uf, 500V	C50180-19
C27	Electrolytic, 3 Section: A—40uf, 450V B—40uf, 400V C—20uf, 300V	C50180-18
C28, 29	Ceramic, 27, 1000V	C50070-10
C30	Ceramic, 82, 1000V	C50070-7

RESISTORS AND POTENTIOMETERS

In ohms, 5% tolerance, 1/3 watt, unless otherwise noted. K=Kilohms, M=Megohms.

Symbol	Description	Part No.
R1	Dep. Carbon, 220K	R33DC224J
R2	Dep. Carbon, 56K	R33DC563J
R3	Dep. Carbon, 220K	R33DC224J
R4, 5, 6	Dep. Carbon, 56K	R33DC563J
R7, 8	Dep. Carbon, 10K	R33DC103J
R9	Glass, 330K, 1W	R30G334J
R10	Glass, 2.2K, 1W	R30G222J
R11	Dep. Carbon, 100K	R33DC104J
R12	Glass, 330K, 1W	R30G334J
R13	Glass, 2.2K, 1W	R30G222J
R14, 15	Dep. Carbon, 2.2M	R33DC225J
R16, 17	Dep. Carbon, 220K	R33DC224J
R18	Dep. Carbon, 680K	R33DC684J
R19	Dep. Carbon, 100K	R33DC104J
R20	Dep. Carbon, 680K	R33DC684J
R21, 22	Dep. Carbon, 330K	R33DC334J
R23, 24	Composition, 10M, 10%, 1/2 W	RC20BF106K
R25	Dep. Carbon, 1M	R33DC105J
R26	Dep. Carbon, 2.2M	R33DC225J
R27	Dep. Carbon, 1M	R33DC105J
R28	Dep. Carbon, 2.2M	R33DC225J
R29	Dep. Carbon, 150K	R33DC154J
R30	Dep. Carbon, 1.5K	R33DC152J
R31	Dep. Carbon, 150K	R33DC154J
R32	Dep. Carbon, 1.5K	R33DC152J
R33	Dep. Carbon, 220K	R33DC224J
R34	Dep. Carbon, 470K	R33DC474J
R35	Dep. Carbon, 220K	R33DC224J

R36	Dep. Carbon, 470K	R33DC474J
R37	Potentiometer, Dual, Bass, 500K	R50160-116
R38, 39	Dep. Carbon, 10K	R33DC103J
R40	Potentiometer, Dual, Treble, 500K	R50160-116
R41	Dep. Carbon, 82K	R33DC823J
R42	Dep. Carbon, 2.2K	R33DC222J
R43	Dep. Carbon, 82K	R33DC823J
R44	Dep. Carbon, 2.2K	R33DC222J
R45, 46	Dep. Carbon, 22K	R33DC223J
R47	Potentiometer, Volume, 500K	R50160-117
R48	Potentiometer, Balance, 500K	R50160-115
R51	Dep. Carbon, 470K	R33DC474J
R52	Dep. Carbon, 1.2K	R33DC122J
R53	Dep. Carbon, 1K	R33DC102J
R54	Dep. Carbon, 220	R33DC221J
R55	Dep. Carbon, 470K	R33DC474J
R56	Dep. Carbon, 1.2K	R33DC122J
R57	Dep. Carbon, 1K	R33DC102J
R58	Dep. Carbon, 220	R33DC221J
R59	Potentiometer, 25K, Channel A, AC Bal.	R50103-2
R60	Dep. Carbon, 39K	R33DC393J
R61	Dep. Carbon, 68K	R33DC683J
R62	Composition, 3.3K, 10%, 1/2 W	RC20BF332K
R63	Potentiometer, 25K, Channel B, AC Bal.	R50103-2
R64	Dep. Carbon, 39K	R33DC393J
R65	Dep. Carbon, 68K	R33DC683J
R66	Dep. Carbon, 330K	R33DC334J
R67	Potentiometer, 5K, Bias Adjust	R50103-4
R68	Glass, 500, 10%, 7W	RPG7W501K
R69	Dep. Carbon, 330K	R33DC334J
R70	Dep. Carbon, 1K	R33DC102J
R71, 72	Dep. Carbon, 330K	R33DC334J
R73	Dep. Carbon, 1K	R33DC102J
R74	Composition, 820, 10%, 1/2 W	RC20BF821K
R75	Dep. Carbon, 1K	R33DC102J
R76, 77	Dep. Carbon, 330K	R33DC334J
R78	Dep. Carbon, 1K	R33DC102J
R79	Glass, 2.2K, 10%, 7W	RPG7W222K
R80	Composition, 2.2K, 10%, 1W	RC30BF222K
R81	Composition, 2.2K, 10%, 1/2 W	RC20BF222K
R82	Composition, 100K, 10%, 1/2 W	RC20BF104K
R83, 84	Glass, 25, 10%, 5W	RPG5W250K
R85, 86	Composition, 330, 10%, 1W	RC30BF331K

MISCELLANEOUS

Symbol	Description	Part No.
CR1, 2	Silicon Rectifier	SR50411-1
F1	Fuse, 3.2A, Slo-Blo	F3319
I1	Bulb, #47	I50009-1
PC1, 2	Printed Circuit, Phono-Tape Equalization	PC50187-3
PC3, 4	Printed Circuit, High Filter	PC50187-2
PC5, 6	Printed Circuit, Tone Control	PC50187-9
S1	Switch, Pushbutton Selector	S951-126
S2	Switch, Mode Selector	S951-124
S3, 4, 5, 6	Switch, Slide	S50200-5
S7	Switch, Power	Part of R47
S8	Switch, Output Selector	S951-125
T1	Transformer, Output, Channel A	T860-116-5
T2	Transformer, Output, Channel B	T860-116-6
T3	Transformer, Power	T951-115
—	Dress Panel	A5951-108
—	Door & Hinge Ass'y	A5951-119
—	Knob	E50325-1
—	Knob, Tone Control, Rear	E50221
—	Knob, Tone Control, Front	E50323
—	Knob, Pushbutton	E851-116
—	Jewel, Green	I50162-4

SCHEMATIC DIAGRAM

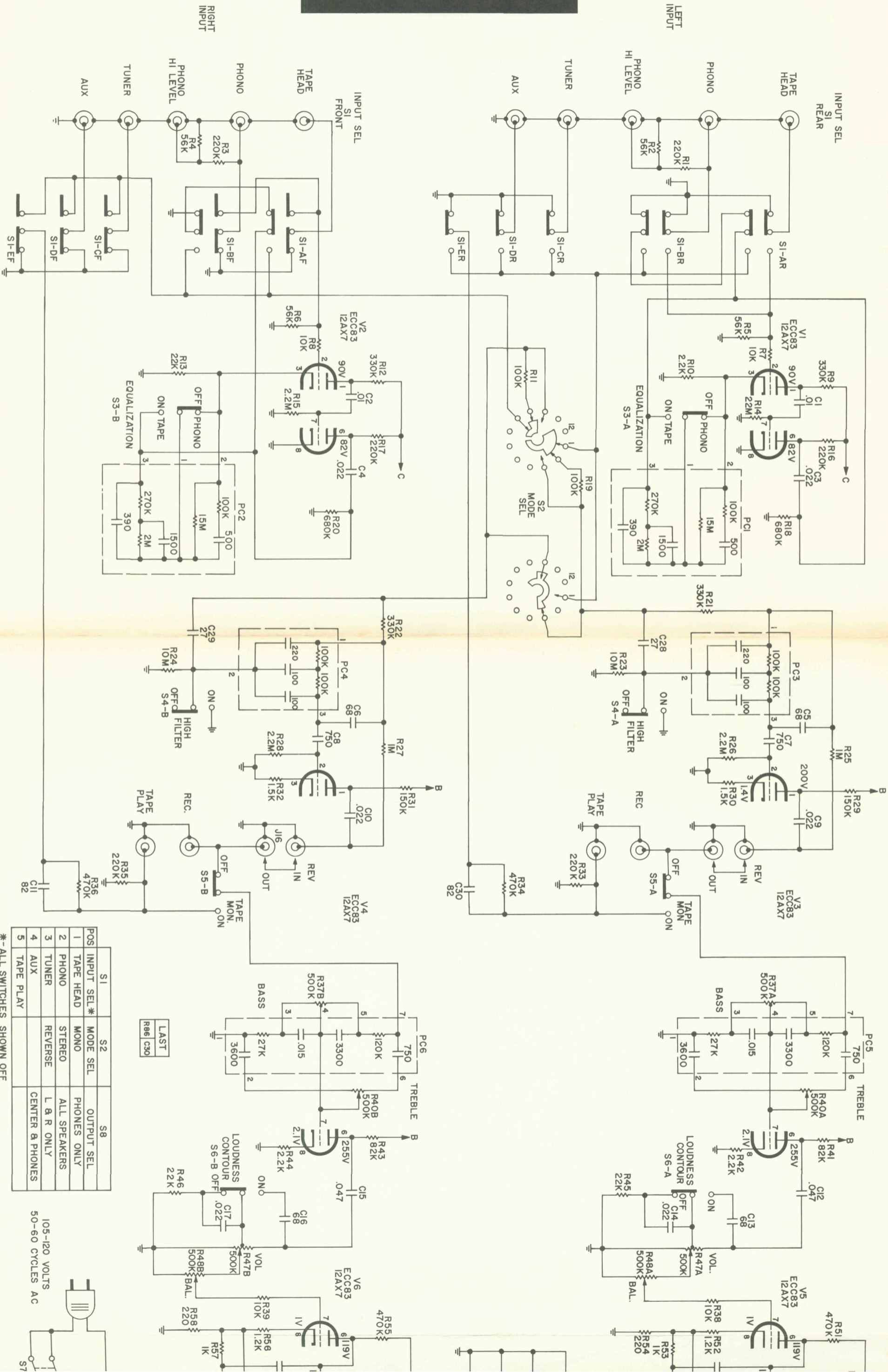

POS	S1	S2	S8
1	INPUT SEL*	MODE SEL	OUTPUT SEL
2	TAPE HEAD	MONO	PHONES ONLY
3	PHONO	STEREO	ALL SPEAKERS
4	TUNER	REVERSE	L & R ONLY
5	AUX		CENTER & PHONES
6	TAPE PLAY		

* - ALL SWITCHES SHOWN OFF

105-120 VOLTS
50-60 CYCLES AC



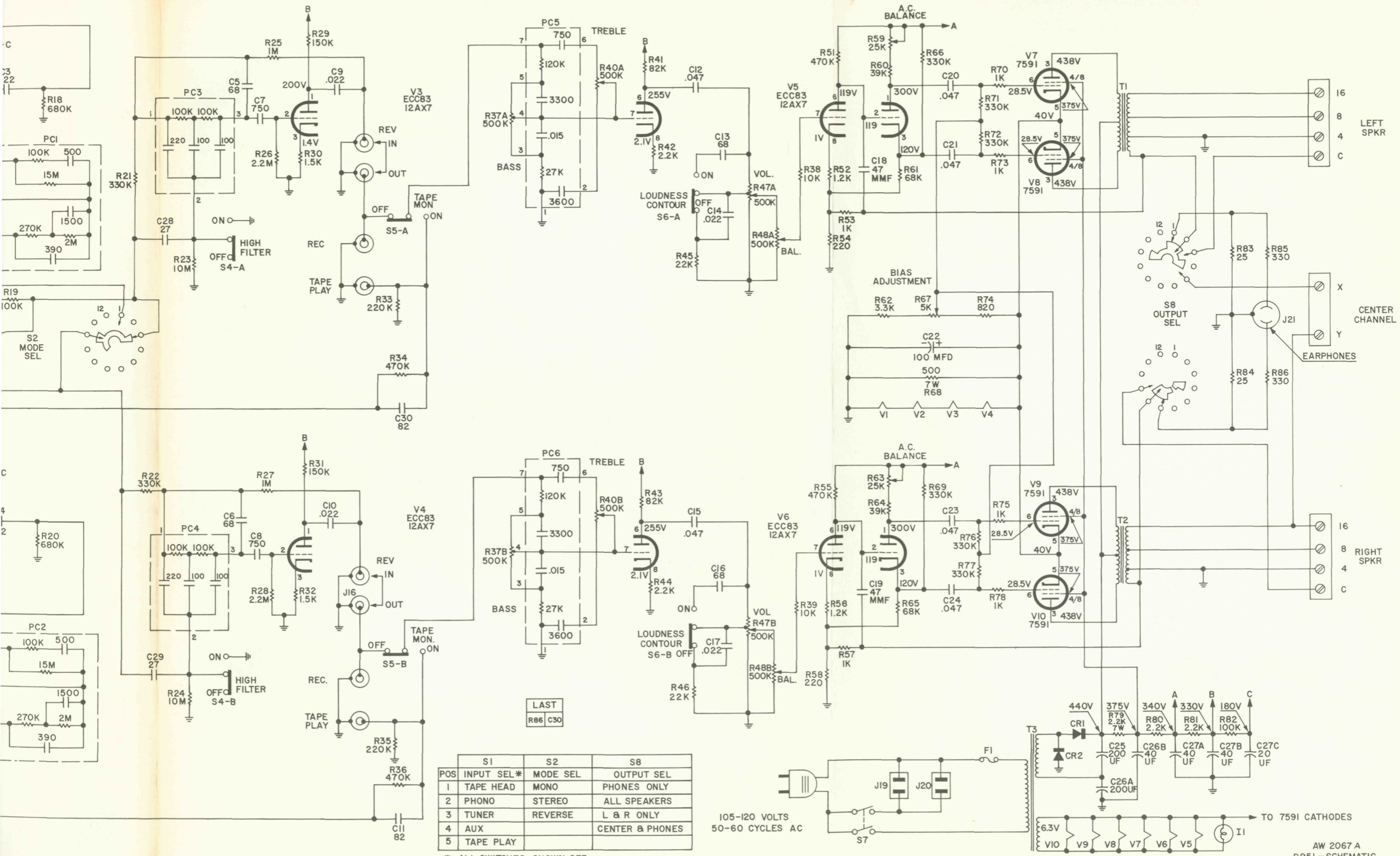

LAST
R86 C30

POS	S1 INPUT SEL*	S2 MODE SEL	S8 OUTPUT SEL
1	TAPE HEAD	MONO	PHONES ONLY
2	PHONO	STEREO	ALL SPEAKERS
3	TUNER	REVERSE	L & R ONLY
4	AUX		CENTER & PHONES
5	TAPE PLAY		

*- ALL SWITCHES SHOWN OFF

ADJUSTMENTS

Equipment Required: DC VTVM, AC VTVM
IM Analyzer,
4-ohm, non-inductive load resistor
(minimum 25-watt rating)

1 – Bias Adjustment

- a. Set Volume control to minimum.
- b. Connect DC VTVM to Pin 5 of any output tube (V7, V8, V9 or V10).
- c. Adjust "Bias" control for 40.0 volts.

2 – Phase Inverter Adjustment

IMPORTANT: Note in the schematic that the C (common) speaker terminals are not grounded—the 4-ohm terminals are grounded. Never ground the C terminals either directly or accidentally through test equipment common ground leads.

Channel A

- a. Connect a 4-ohm load between C and 4 left speaker terminals.
- b. Connect IM Distortion Analyzer output to channel A AUX input.
- c. Connect the Analyzer input ground lead to the left speaker 4-ohm terminal.
- d. Connect the Analyzer input hot lead to the left speaker C terminal.
- e. Set the Selector switch to AUX, the Mode switch to STEREO, and adjust the Analyzer for 8.0 volts across the 4-ohm load.
- f. Adjust the CH A Phase Inverter control for minimum IM distortion.

Channel B

- a. Connect a 4-ohm load between C and 4 right speaker terminals.
- b. Connect IM Distortion Analyzer output to channel B AUX input.
- c. Connect the Analyzer input ground lead to the right speaker 4-ohm terminal.
- d. Connect the Analyzer input hot lead to the right speaker C terminal.
- e. Set the Selector switch to AUX, the Mode switch to STEREO, and adjust the Analyzer for 8.0 volts across the 4-ohm load.
- f. Adjust the CH B Phase Inverter control for minimum IM distortion.

TUBE LAYOUT

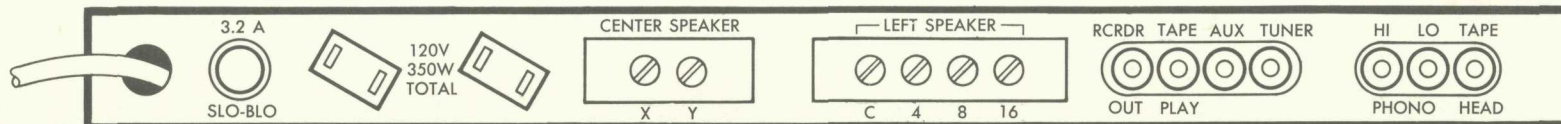
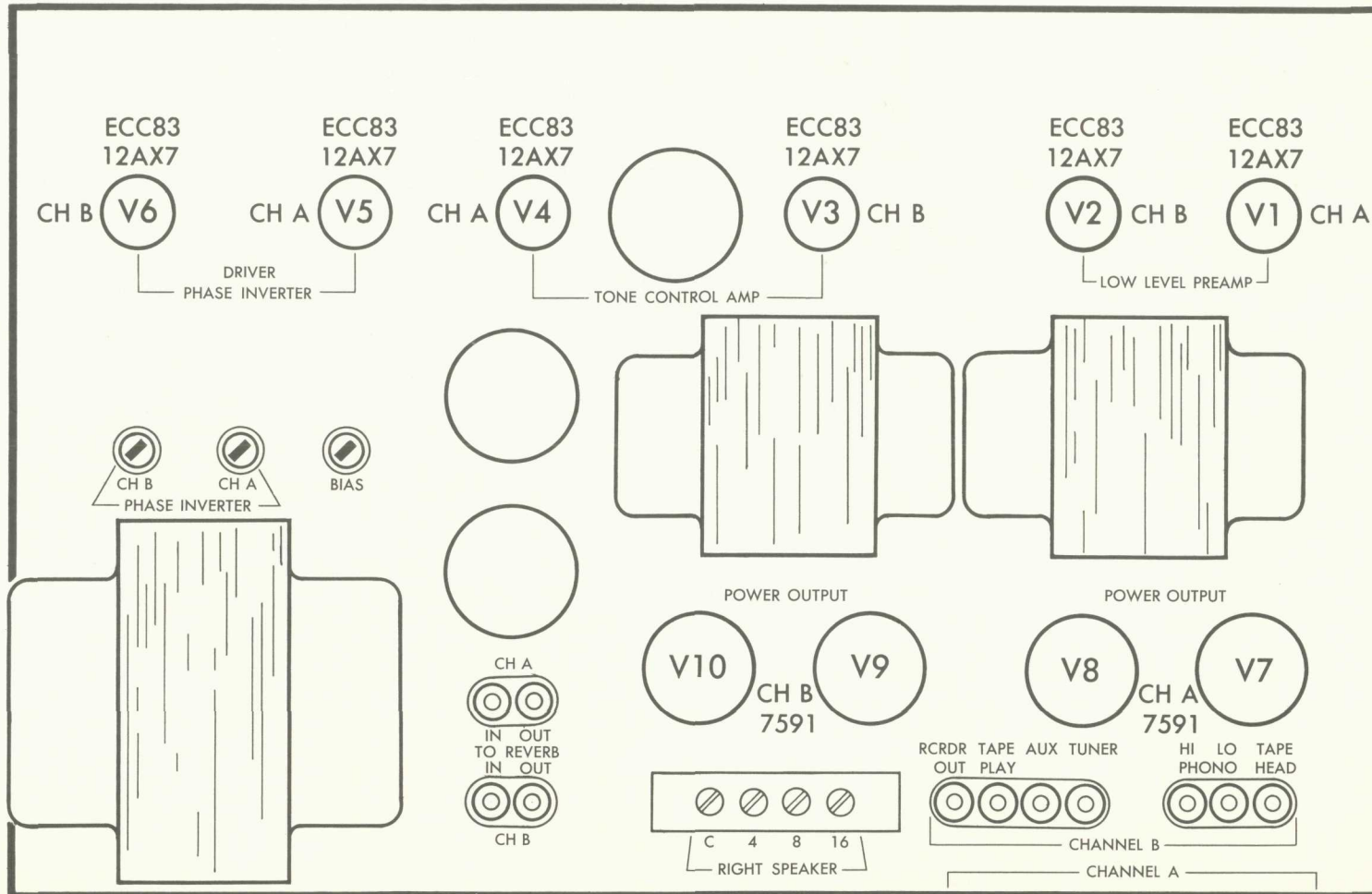

SERVICE NOTES



FISHER RADIO CORPORATION • NEW YORK

N951-104A

© 1962 FISHER RADIO CORPORATION

PRINTED IN U. S. A.

527-G27C-92