

Stereophonic

THE FISHER X-202-B

SERVICE MANUAL



MODEL X-202-B

CHASSIS SERIAL NUMBERS
FROM 50001 TO 59999 INCLUSIVE

PRICE: \$1.00

FISHER RADIO CORPORATION • NEW YORK



CHASSIS SERIAL NUMBERS
FROM 50001 TO 59999 INCLUSIVE

THE FISHER X-202-B



TUBE LAYOUT

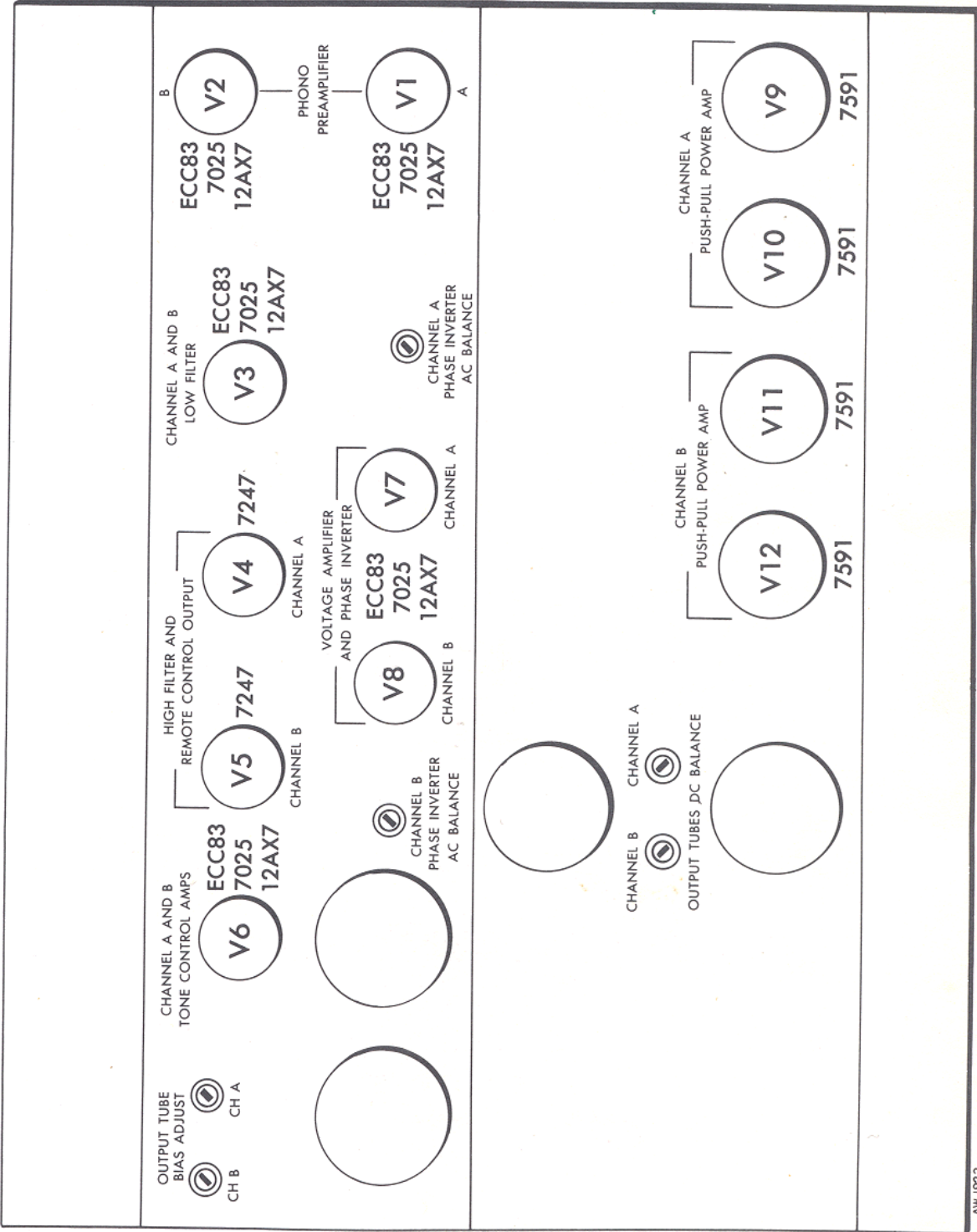

PARTS DESCRIPTION LIST

CAPACITORS

10% tolerance for all fixed capacitors, unless otherwise noted or marked GMV (guaranteed minimum value).

Symbol	Description	Part No.
C1, 2	Ceramic, 100uf, GMV, N1500, 1000V	C50070-5
C3, 4	Ceramic, 100uf, N1500, 1000V	C50070-6
C5, 6	Mylar, .022uf, 400V	C50197-28
C7, 8	Mylar, .047uf, 400V	C50197-30
C9, 10	Ceramic, 21uf, 5%, N750, 1000V	C50070-32
C11, 12	Ceramic, .005uf, 20%, 500V	C50089-1
C13, 14	Electrolytic, 50uf, 3V	C50283-1
C15, 16	Mylar, .047uf, 400V	C50197-30
C17, 18	Ceramic, .0027uf, 1000V	C50072-17
C19, 20	Ceramic, 18uf, N470, 1000V	C50070-13
C21, 22	Electrolytic, 50uf, 3V	C50283-1
C23, 24	Ceramic, 820uf, 1000V	C50072-7
C25, 26	Mylar, 1uf, 150V	C50197-78
C27, 28	Ceramic, 200uf, 1000V	C50072-22
C29, 30	Mylar, .022uf, 250V	C50197-49
C31, 32	Mylar, .047uf, 400V	C50197-30
C33, 34	Electrolytic, 50uf, 3V	C50283-1
C35, 36	Mylar, .015uf, 250V	C50197-49
C37, 38	Ceramic, 680uf, 1000V	C50072-2
C39, 40	Ceramic, 56uf, N1500, 1000V	C50070-22
C41, 42, 43, 44	Mylar, .047uf, 400V	C50197-30
C45, 46	Ceramic, 10uf, NPO, 1000V	C50070-11
C47, 48	Ceramic, 330uf, 1000V	C50072-1
C49	Electrolytic, 200uf, 250V	C50180-20
C50	Electrolytic, 2 section A — 40uf, 500V B — 20uf, 250V	C50180-19
C51	Electrolytic, 4 section A — 40uf, 450V B — 40uf, 400V C — 20uf, 300V D — 20uf, 300V	C50180-12
C52	Electrolytic, 20uf, 250V	C746-145
C53	Electrolytic, 2 section, com. Pos. A — 1000uf, 35V B — 1000uf, 35V	C50180-37
C54	Electrolytic, 50uf, 70V	C50283-2

RESISTORS AND POTENTIOMETERS

In ohms, 10% tolerance, 1/2 watt, unless otherwise noted. K=Kilohm, M=Megohm.

Symbol	Description	Part No.
R1, 2, 3, 4, 5, 6	Dep. Carbon, 100K, 5%, 1/2 W	R33DC104J
R7, 8	Potentiometer, 250K, aux-1 level	R50103-1
R9, 10	Dep. Carbon, 150K, 5%, 1/2 W	R33DC154J
R11, 12	Dep. Carbon, 120K, 5%, 1/2 W	R33DC124J
R13, 14	Dep. Carbon, 10K, 5%, 1/2 W	R33DC103J
R15, 16	Glass, 2.2K, 5%, 1W	R30G222J
R17, 18	Glass, 330K, 5%, 1W	R30G334J
R19, 20	Dep. Carbon, 4.7M, 5%, 1/2 W	R33DC475J
R21, 22	Dep. Carbon, 220K, 5%, 1/2 W	R33DC224J
R23, 24	Potentiometer, 250K, dual, low level	R50160-99
R25, 26	Dep. Carbon, 100K, 5%, 1/2 W	R33DC104J
R27, 28	Dep. Carbon, 330K, 5%, 1/2 W	R33DC334J
R29, 30, 31, 32	Dep. Carbon, 1M, 5%, 1/2 W	R33DC475J
R33, 34, 35, 36	Dep. Carbon, 120K, 5%, 1/2 W	R33DC124J
R37, 38	Dep. Carbon, 1.5K, 5%, 1/2 W	R33DC152J
R39, 40	Composition, 10M	RC20BF106K
R41, 42	Dep. Carbon, 330K, 5%, 1/2 W	R33DC334J
R43, 44	Dep. Carbon, 1.5M, 5%, 1/2 W	R33DC155J
R45, 46	Dep. Carbon, 150K, 5%, 1/2 W	R33DC154J
R47, 48	Dep. Carbon, 1.5K, 5%, 1/2 W	R33DC152J
R49, 50	Dep. Carbon, 1M, 5%, 1/2 W	R33DC105J
R51, 52	Dep. Carbon, 1.5K, 5%, 1/2 W	R33DC152J
R53, 54	Composition, 22K, 1W	RC30BF223K
R55, 56	Dep. Carbon, 22K, 5%, 1/2 W	R33DC223J
R57, 58	Dep. Carbon, 10K, 5%, 1/2 W	R33DC103J
R59	Potentiometer, dual, 100K, volume	R50160-84

R60	Potentiometer, dual, 500K, treble	R50169-85
R61	Potentiometer, dual, 1M, bass	R50160-87
R62, 63	Dep. Carbon, 150K, 5%, 1/2 W	R33DC154J
R64, 65	Dep. Carbon, 1.5K, 5%, 1/2 W	R33DC152J
R66	Potentiometer, dual, 300K, bal., 1M, dim.	R50160-100
R67, 68	Composition, 82K	RC20BF823K
R69, 70	Composition, 820K	RC20BF824K
R71, 72	Composition, 220	RC20BF221K
R73, 74	Composition, 560K, 5%	RC20BF564J
R75, 76	Dep. Carbon, 1K, 5%, 1/2 W	R33DC102J
R77, 78	Composition, 1.8K, 5%	RC20BF182J
R79, 80	Composition, 27K	RC20BF273K
R81, 82	Dep. Carbon, 330K, 5%, 1/2 W	R33DC334J
R83, 84	Dep. Carbon, 47K, 5%, 1/2 W	R33DC473J
R85, 86	Composition, 27K	RC20BF273K
R87, 88	Potentiometer, 50K, AC balance	R50103-3
R89, 90, 91, 92	Dep. Carbon, 330K, 5%, 1/2 W	R33DC334J
R93, 94	Potentiometer, 10K, DC balance	R50103-5
R95, 96, 97, 98	Composition, 68K, 5%	RC20BF683J
R99, 100, 101, 102	Dep. Carbon, 1K, 5%, 1/2 W	R33DC102J
R103, 104	Wirewound, 10, 5W	R779-103
R105, 106, 107	Composition, 4.7K	RC20BF472K
R108, 109	Composition, 330, 1W	RC30BF222K
R110, 111	Glass, 24, 7W	RPG7W240K
R112, 113	Composition, 27K	RC20BF273K
R114	Composition, 33K, 1W	RC20BF333K
R115	Composition, 8.2K, 1W	RC30BF822K
R116	Glass, 1.5K, 4W	RPG4W152K
R117	Composition, 10K, 1W	RC30BF103K
R118	Composition, 33	RC20BF330K
R119, 120	Composition, 220	RC20BF221K
R121	Wirewound, 15, 5W	R719-106
R122	Composition, 2.7K	RC20BF272K
R123	Composition, 18K	RC20BF183K
R124, 125	Potentiometer, 10K, bias	R50103-5
R126, 127	Composition, 560K, 5%	RC20BF564J
R128, 129	Wirewound, 25, 5W	R688-117

MISCELLANEOUS

Symbol	Description	Part No.
F1	Fuse, 3.2 Amp., Slo-Blo	F3319
I1, 2, 3, 4, 5	Bulb, #47	I50009-1
PC1, 2	Printed Circuit, 3 3/4" Tape Equalization	PC50187-7
PC3, 4	Printed Circuit, RIAA, Tape 7 1/2"	PC50187-3
PC5, 6	Printed Circuit, Col. Equalization	PC50187-6
PC7, 8	Printed Circuit, High Filter	PC50187-5
PC9, 10	Printed Circuit, Tone Control	PC657-140
S1	Switch, Input Selector	S841-125
S2	Switch, Mode Selector	S841-136
S3, 4, 5, 6, 7, 8	Switch, Slide	S50200-5
S13	Switch, Power	Part of R59
S15	Switch, Center Speaker	S827-129
SR1, 2	Silicon Diode, B+	SR806-126
SR3, 4	Silicon Diode, Filament & Bias	SR851-122
T1	Transformer, Output CH A	T827-116
T2	Transformer, Output CH B	T827-116
T3	Transformer, Power	T827-115
—	Dress Panel	A5827-123
—	Tube Shield, 9 pin	E3287
—	Knob	E50325-1
—	Knob, Dual, Bottom	E50221
—	Knob, Dual, Top	E50323
—	Knob, Dummy Dual	E50324
—	Plastic Foot	H50277
—	Jewel, Red	I50162-1
—	Jewel, Yellow	I50162-2
—	Jewel, Green	I50162-4
—	Jack, Earphone	J846-120-1
—	Fuse Holder	X50329

ADJUSTMENTS

1—OUTPUT BIAS ADJUSTMENT

- a. Set Volume control to minimum.
- b. Connect DC VTVM to Pin 5 of V9 or V10.
- c. Adjust Channel A Bias Control until VTVM reads 0.8 volt.
- d. Connect DC VTVM to Pin 5 of V11 or V12 and adjust Channel B Bias control until VTVM reads 0.8 volt.
- e. Repeat steps a through d until both readings are equal.

2—AC BALANCE AND OUTPUT TUBE DC BALANCE ADJUSTMENT

Channel A

- a. Connect a 4-ohm load to the left speaker output.
- b. Connect Impedance Selector (lead protruding from rear of chassis) to 4-ohm tap on left speaker terminal strip.
- c. Connect IM Distortion Analyzer output to the AUX-1 input for Channel A.
- d. Connect the Analyzer input ground lead to the left speaker lug within the SPKR brackets and next to the 4-ohm lug.
- e. Connect the hot lead from the Analyzer input to the remaining lug within the SPKR brackets.
- f. Set the input Selector switch to AUX, the Mode Selector switch to STEREO and adjust the Analyzer output until 9.0 volts are indicated across the output load.
- g. Adjust Channel A AC Balance and DC Balance controls for minimum IM distortion. Repeat this adjustment several times.

Channel B

- a. Connect a 4-ohm load between the COM and 4-ohm lugs of the right speaker terminal strip.
- b. Connect IM Distortion Analyzer output to the AUX input for Channel B.
- c. Connect the Analyzer input ground lead to the terminal lug marked 4 on the right speaker terminal strip.
- d. The hot lead from the Analyzer input should be connected to the terminal lug marked COM on the right speaker terminal strip.
- e. Set the Input Selector switch to AUX, the Mode Selector switch to STEREO and adjust the Analyzer output until 9.0 volts are indicated across the output load.
- f. Adjust Channel B AC Balance and DC Balance controls for minimum IM distortion. Repeat this adjustment several times.

SCHEMATIC DIAGRAM

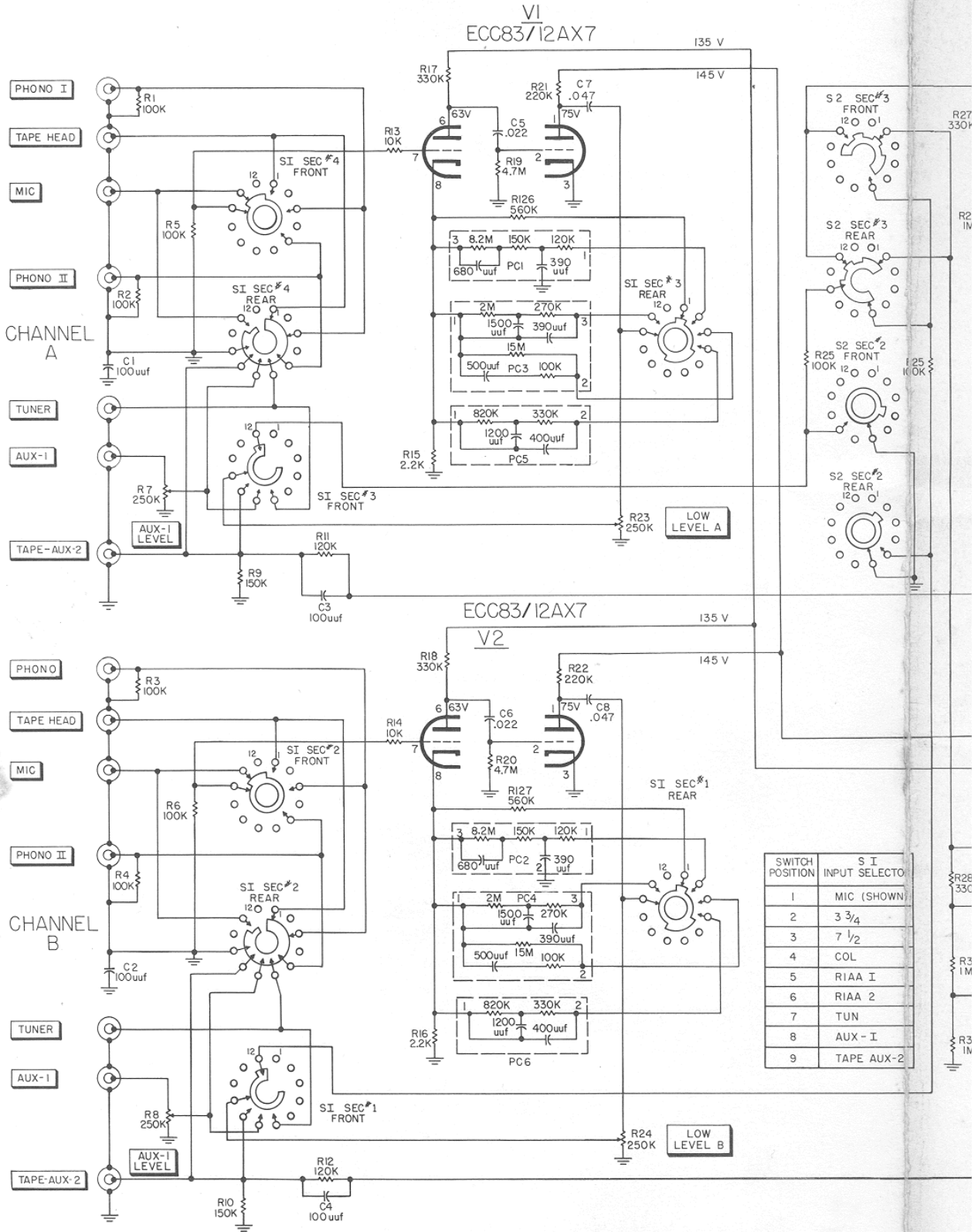

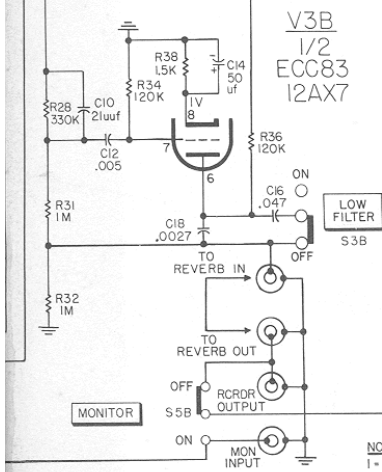
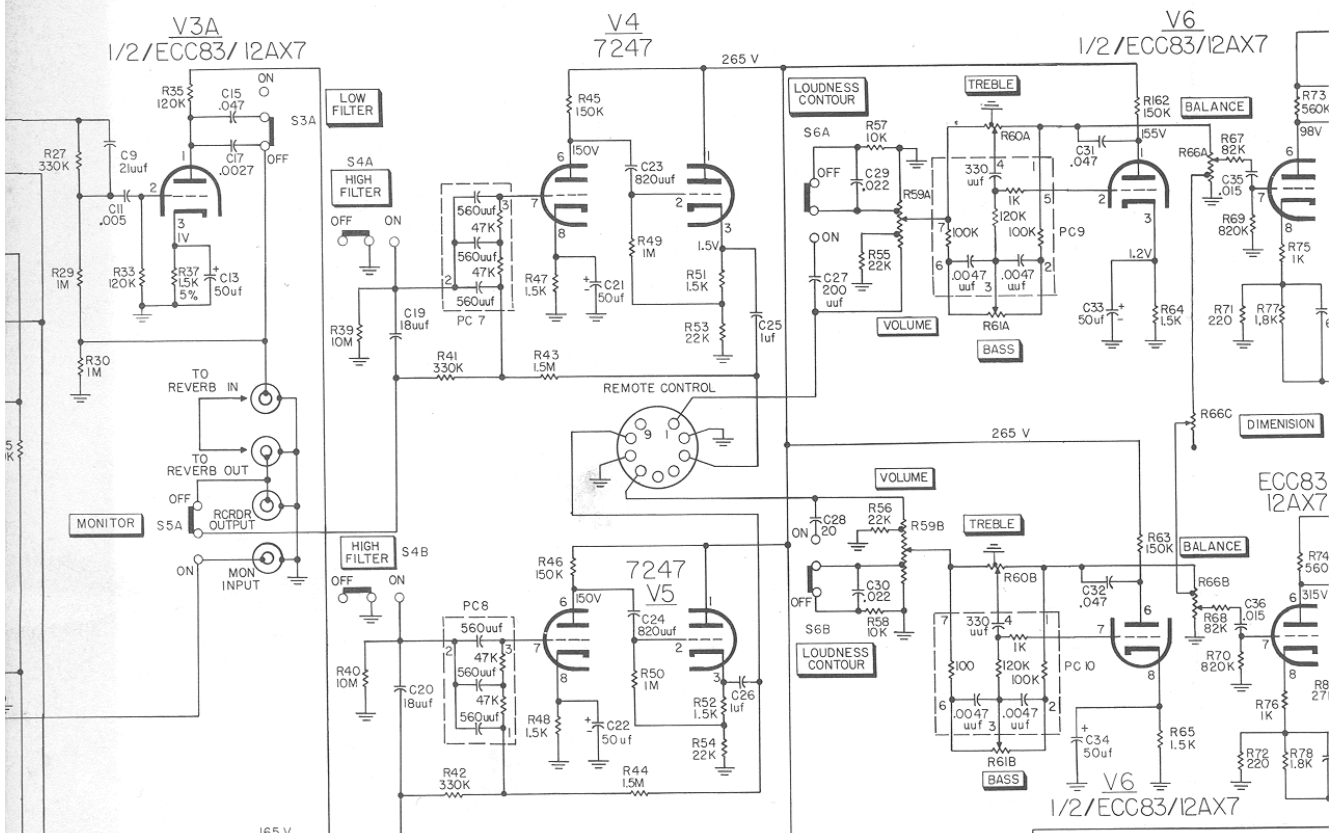

SWITCH POSITION		S15 CENTER SPEAKER
1	OFF (SHOWN)	
2	1	
3	2	
4	3	
5	MAX.	

SWITCH POSITION		S2 MODE SELECTOR
1	MONO PHONO (SHOWN)	
2	REVERSE	
3	STEREO	
4	A	
5	B	

DUMMY PLUG (MALE)
MUST BE INSERTED IN ALL
SETS WITH NO REMOTE CONTROL
UNIT.

NOTES:
1- ALL VOLTAGES MEASURED WITH VTVM AND REFERENCED TO CHASSIS GROUND, -NO SIGNAL, BOTH CHANNELS LOADED WITH 16 Ω.
2- ALL SLIDE-SWITCHES SHOWN IN NORMAL OFF POSITION.

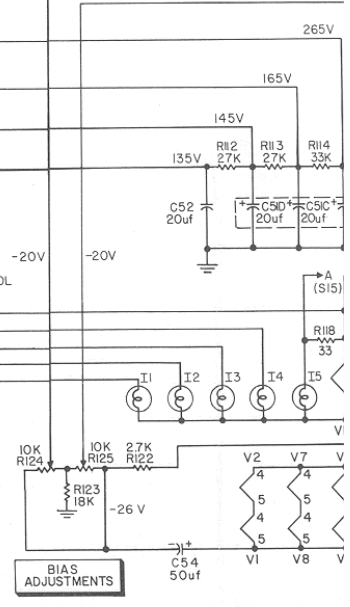

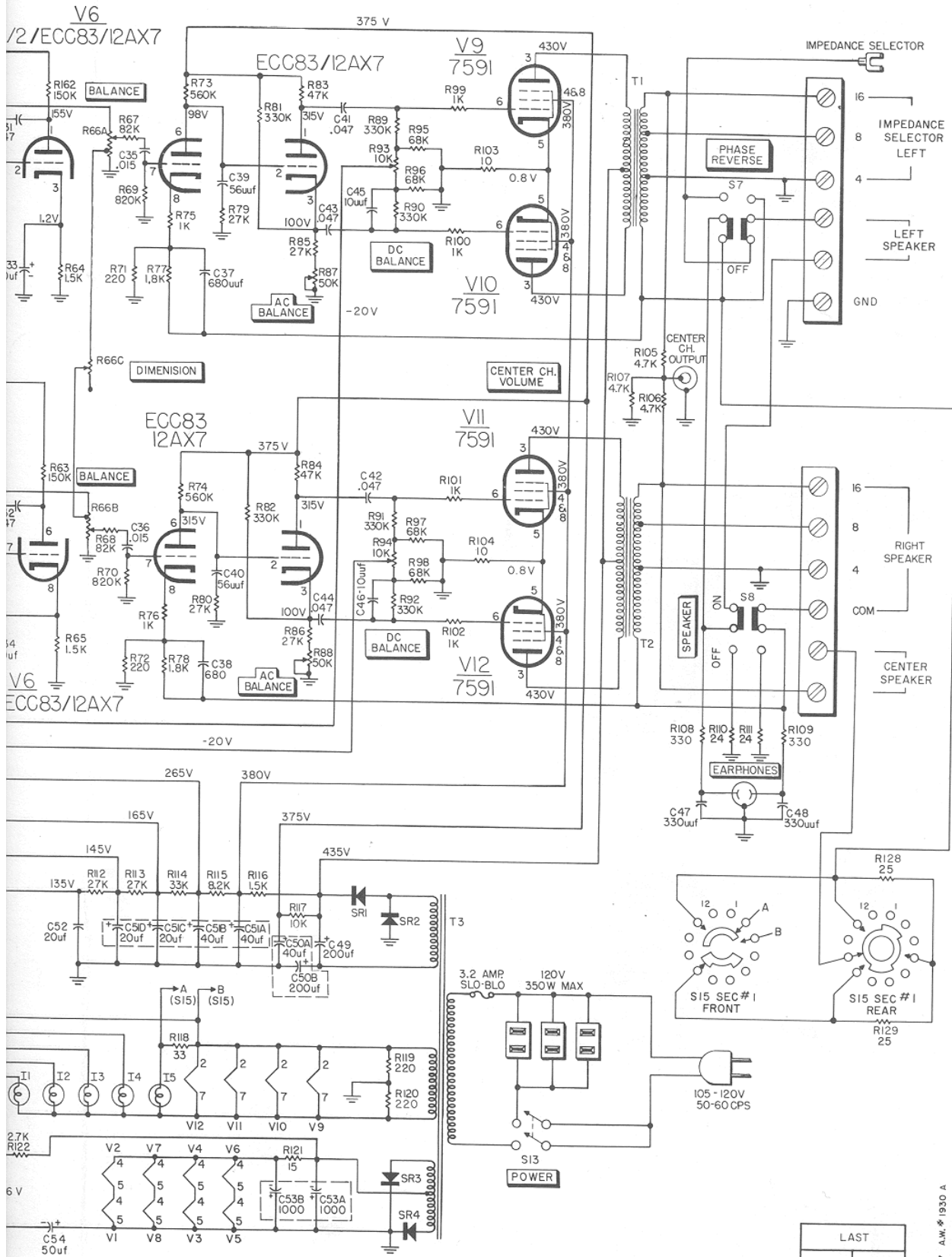

LAST	
R129	C54