Service Manual

Model

VF-16

DIGITAL MULTITRACKER

FOSTEX®

Press the [ENTER/YES] key in the above display condition. The display indicates the free audio file numbers.

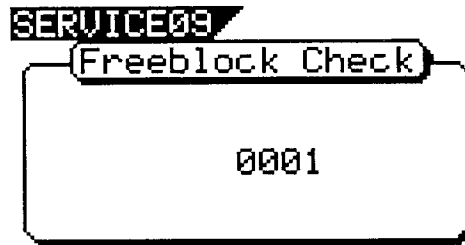

If the Free Block indicates a large number even right after formatting and no signal is recorded or if the recorded signal on the E-IDE HDD is frequently skipped, the diskette / hard disk drive can be judged to be in a bad condition.

4-8. Product Initialize

This mode is exclusively used at our assembly line and has nothing to do with servicing the unit.

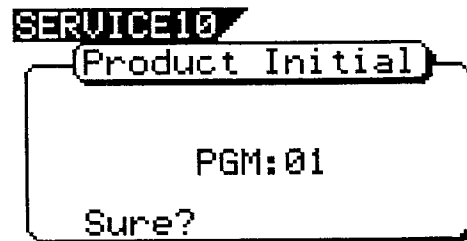

4-9. Key & LED Check Tests

These two tests are different from the before mentioned tests. It is not necessary to put the unit into the Service Mode to execute these tests.

4-9-1. Key & LED Check

This test checks in which color the LEDs on the top panel is lit and if the key is correctly pressed or not. To execute, press the CH9 (A) STATUS/CH SEL key while holding down the SHIFT and STOP keys. The LEDs are lit in the following color.

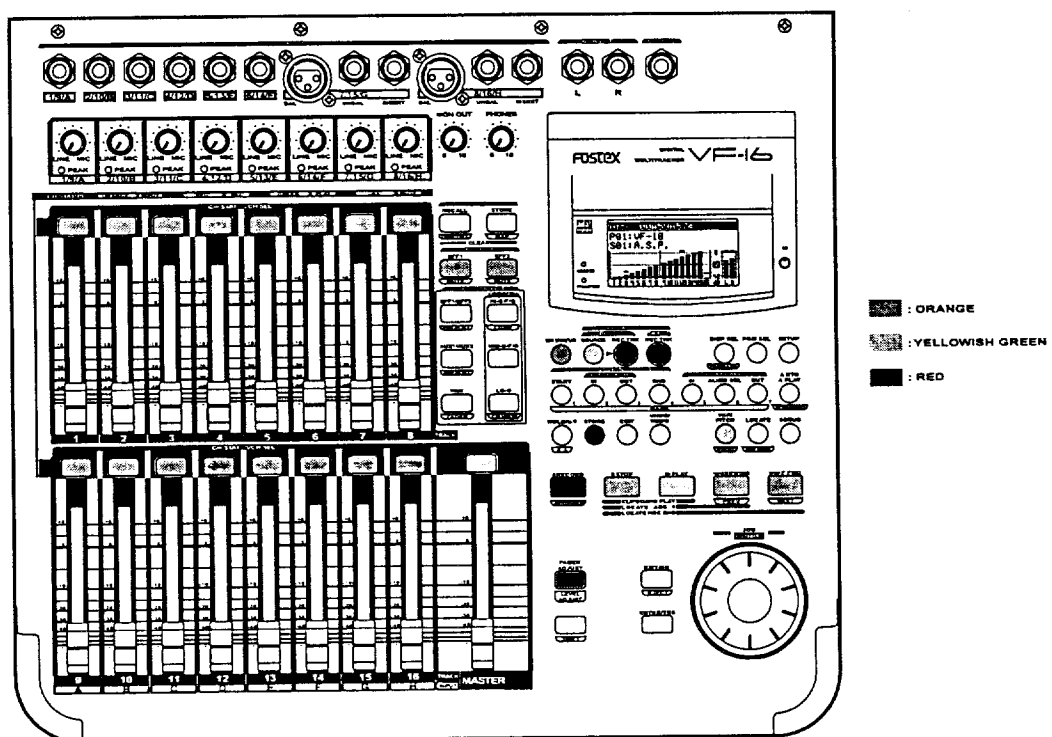

The LCD indicates the following in this mode.

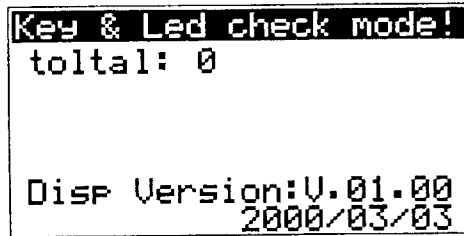

If one of the keys on the top panel is pressed, the LCD indicates the following. The message "OK" indicates that the pressed key (SW) is in good contact.

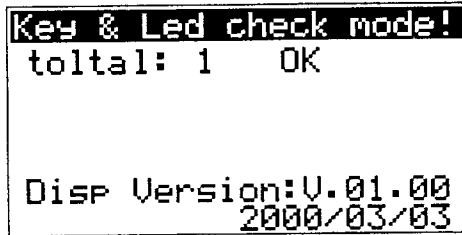

If two or more keys on the top panel are pressed at the same time, the message "ERROR" will be displayed on the LCD. In the meantime, the names of the pressed keys are displayed. The example below indicates that the [RECORD] and [PLAY] keys are pressed at the same time.

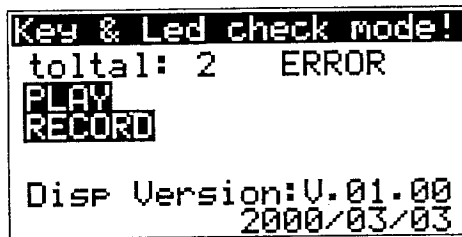

To get out of the test mode, press the MASTER key while holding down the SHIFT and STOP keys.

4-9-2. LED Check 2

This test checks in which (orange / yellowish green / red) color the LEDs on the top panel are lit. Especially the CH STATUS/CH SEL keys are lit in different color depending on the recording mode, etc. To execute, press the CH10 (B) STATUS/CH SEL key while holding down the SHIFT and STOP keys. No LED is lit right after the VF-16 is put into this test. Then, every time the [ENTER/YES] key is pressed, the orange, yellowish green and red LEDs are lit in order.

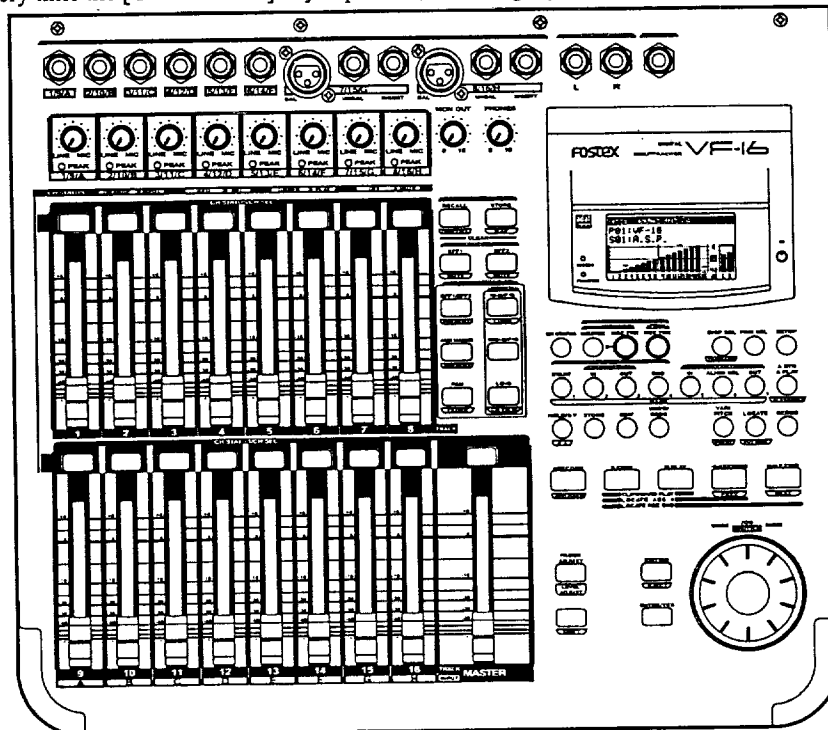



Press the ENTER/YES key.

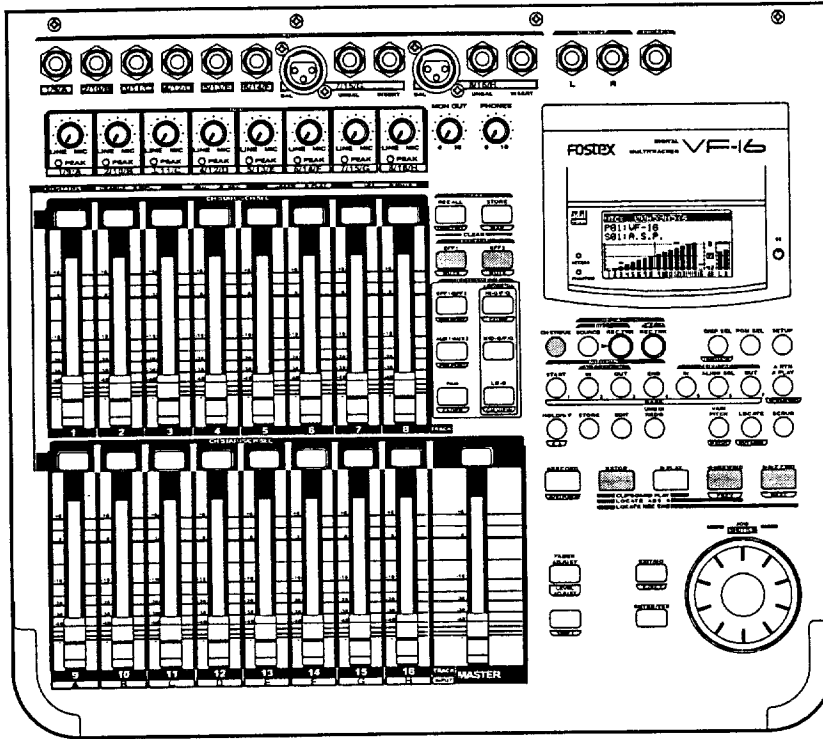

 : ORANGE



Press the ENTER/YES key.

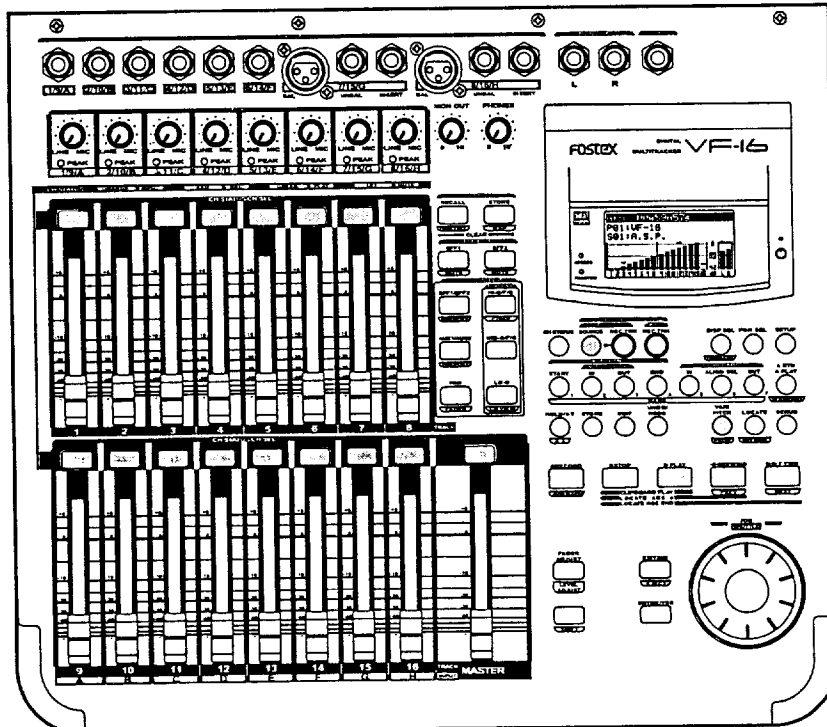

 : YELLOWISH GREEN



Press the ENTER/YES key.

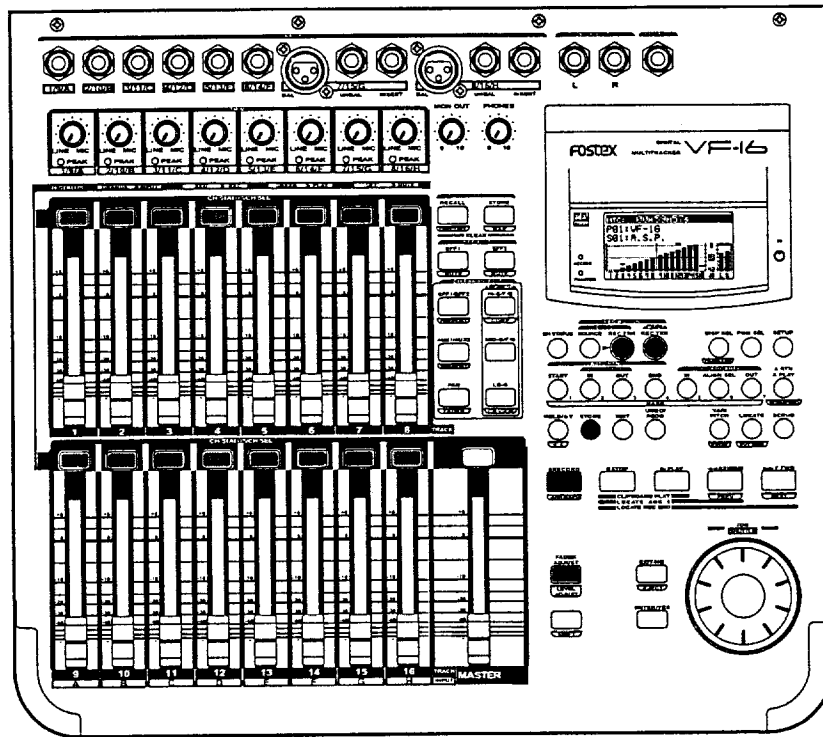

To get out of the test mode, press the MASTER key while holding down the [SHIFT] and [STOP] keys.

• Foil Side of MAIN PCB

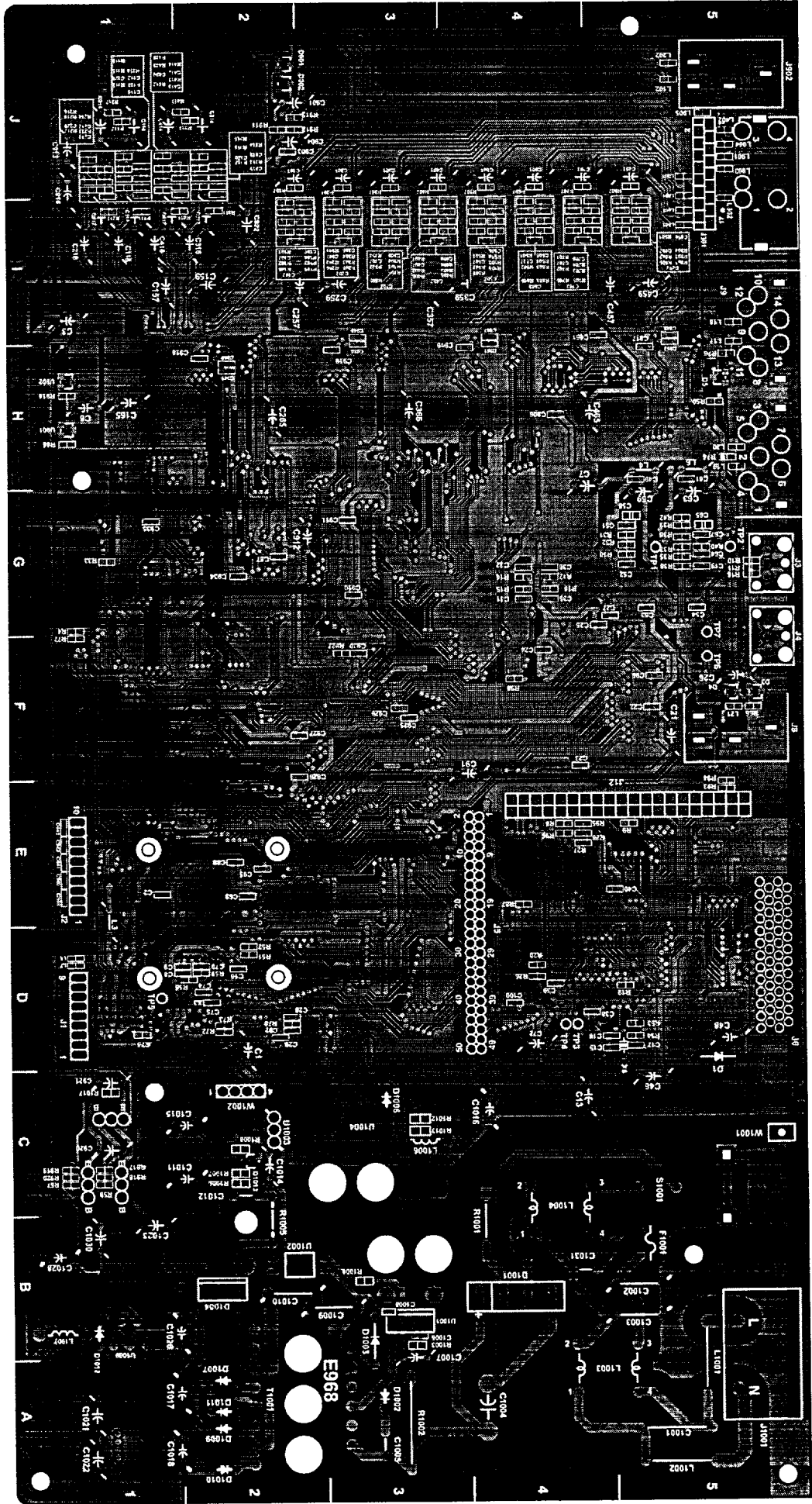

• Parts Side of KEY & KEY2 PCB

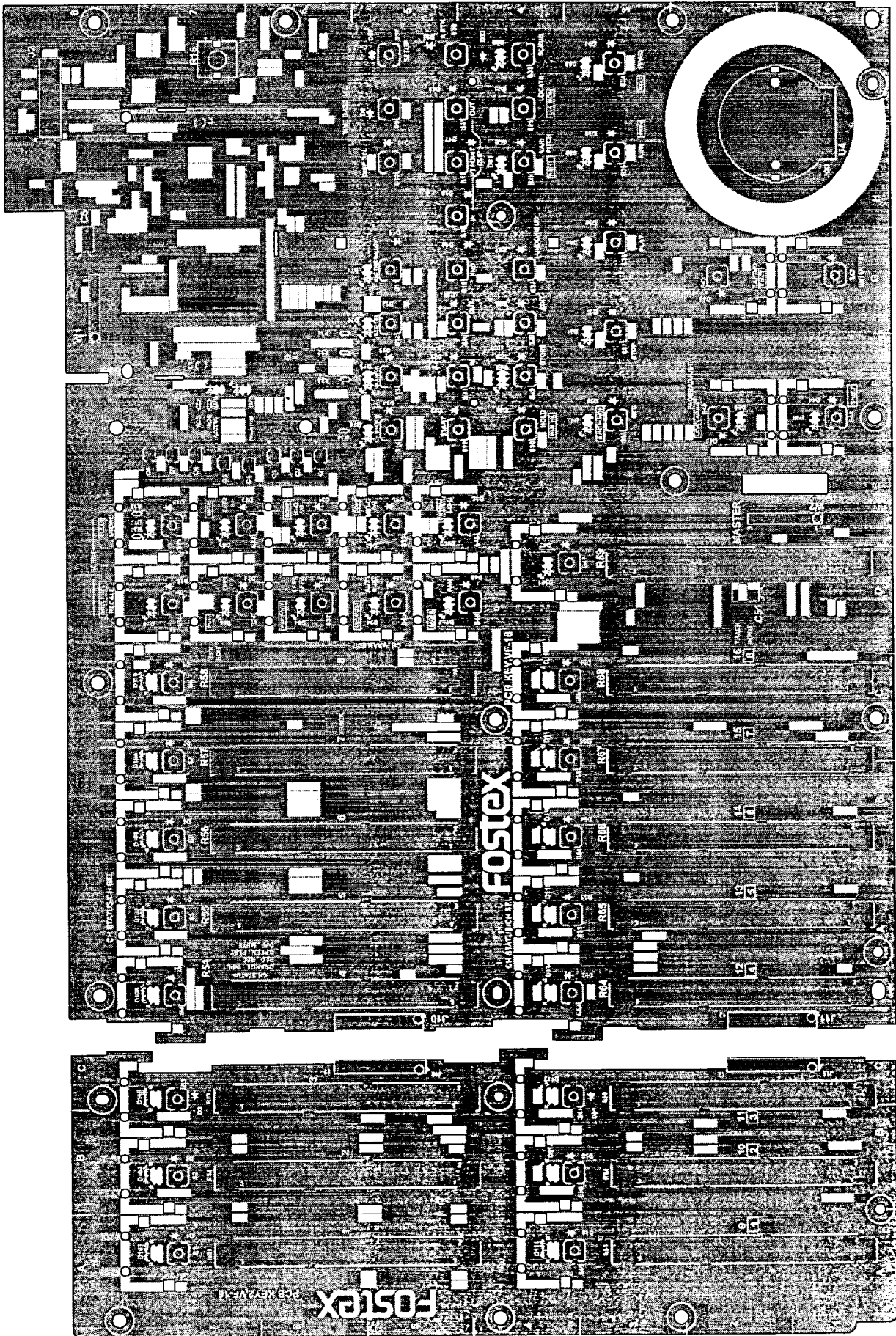

• Foil Side of KEY & KEY2 PCB

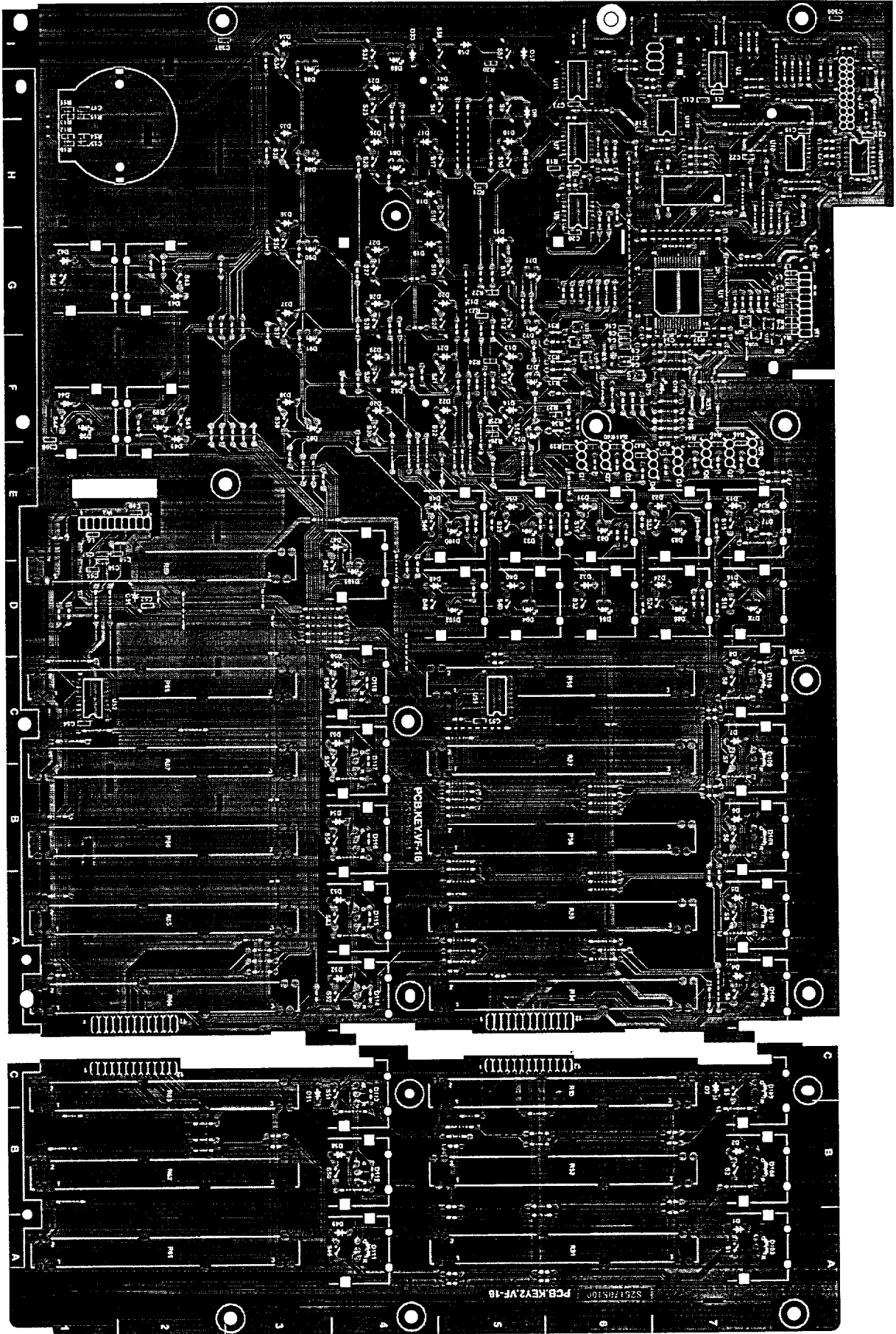

• Parts & Foil Side of MIC/MON PCB

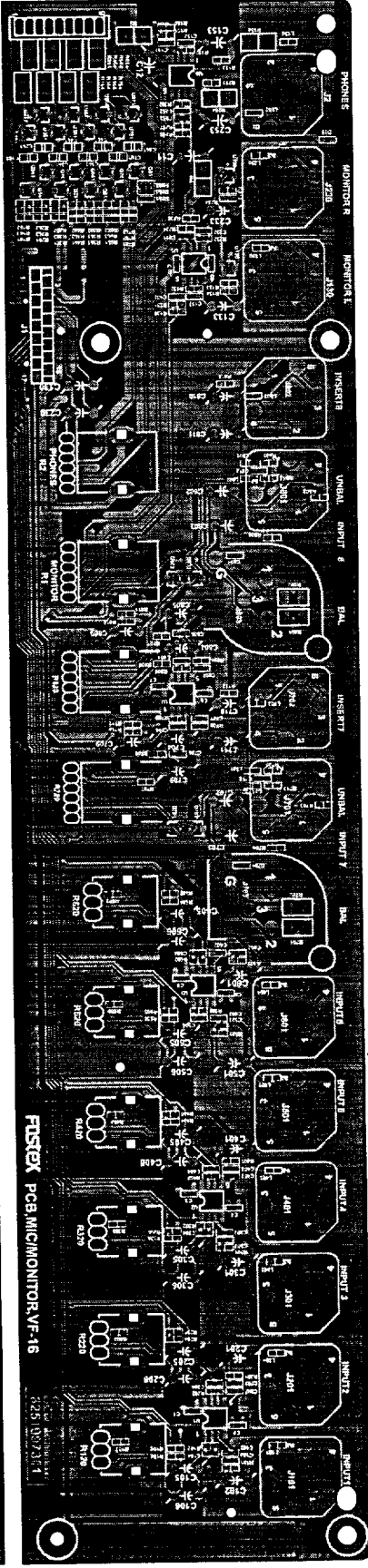
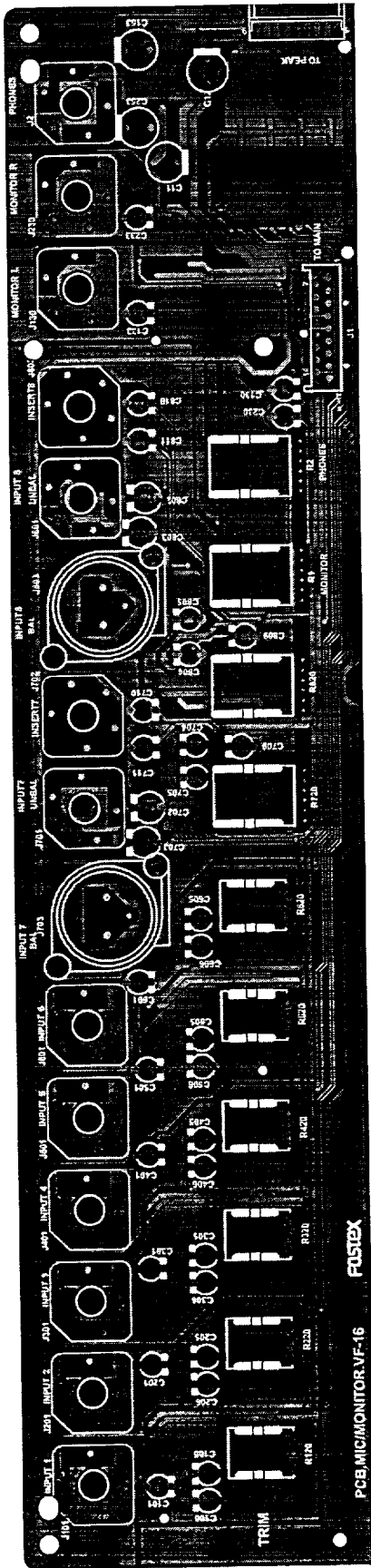

• Parts & Foil Side of LCD PCB

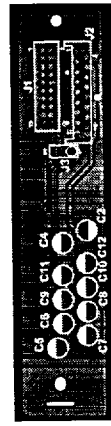

• Parts & Foil Side of PEAK LED PCB

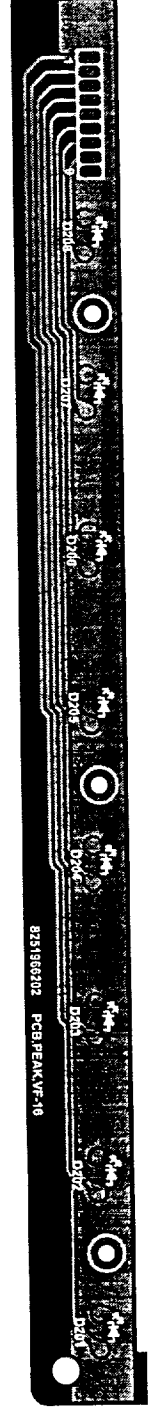

● VF-16 Parts List

• Main PCB assy

Ref. No.	Part No.	Description
	8274 2540 00	PCB Assy, Main, VF-16
	8251 7022 00	Plain PCB, Main, VF-16

ICs

Ref. No.	Part No.	Description
U001	8236 0831 30	SOJ, DG, DRAM, MSM5118160-60JS-7R1
U002	8236 5450 00	ST, TSSOP, 74VHC00
U003	8236 5450 74	ST, TSSOP, 74VHC74
U004, 005	8236 0818 00	QFP, DG, gate array, ASPI
U006	8236 5459 04	ST, TSSOP, 74VHCU04
U007	8236 0828 00	QFP, DG, SCSI, MB86604L
U008	8236 0829 00	SOP, DG, SCSI term, BH9595FP-Y
U009, 010	8236 5034 00	ST, DG, VCO, TC9246F
U011	8234 5047 00	OPT, ST, photo, PC410T
U012	8236 5450 14	ST, TSSOP, 74VHC14
U013	8236 5025 00	ST, AN, reset, NJM2103M
U014	8236 5701 01	ST, DG, driver, DTC114EK
U015	8236 0868 00	QFP, DG, CPU, SH7042, 33MHz, OTP
U017	8236 5459 04	ST, TSSOP, 74VHCU04
U024	8236 5450 32	ST, TSSOP, 74VHC32
U029	8236 5451 57	ST, TSSOP, 74VHC157
U030	8236 0840 11	TSOP, DG, FROM, M29F400T-400
U033	8236 0831 30	SOJ, DG, DRAM, MSM5118160-60JS-7R1
U034	8236 5450 32	ST, TSSOP, 74VHC32
U035	8236 5450 00	ST, TSSOP, 74VHC00
U036	8236 5450 74	ST, TSSOP, 74VHC74
U037	8236 5451 38	ST, TSSOP, 74VHC138
U038	8236 5452 73	ST, TSSOP, 74VHC273
U039	8236 5450 32	ST, TSSOP, 74VHC32
U040		N/A
U041	8236 5450 32	ST, TSSOP, 74VHC32
U042	8236 5452 73	ST, TSSOP, 74VHC273
U043	8236 5450 08	ST, TSSOP, 74VHC08
U101~801	8236 5050 11	ST, AN, op amp, NJM2115M (TEI)
U102, 302	8236 5412 00	ST, AN, op amp, NJM4565M
U103~403	8236 5702 01	ST, DG, driver, DTC314TK
U151~451	8236 0861 00	QFP, DG, DSP, AK7716
U901, 902	8236 5701 01	ST, DG, driver, DTC114EK
U903	8236 5708 03	ST, DG, driver, DTB114EK
U904	8236 5450 04	ST, TSSOP, 74VHC04
U905	8236 0858 00	QFP, DG, gate array, SAA
U906	8236 0846 10	TSOP, DG, SRAM, LC361000ATLL-70-TLM
U908	8236 5701 01	ST, DG, driver, DTC114EK
U910	8236 5701 01	ST, DG, driver, DTC114EK
U911	8236 0858 00	QFP, DG, gate array, SAA
U1001	8236 5410 06	V, AN, power, MIP166
U1002	8234 1081 00	OPT, H, photo coupler, ON3171
U1003	8236 5409 00	VT, AN, regulator, AN1431T
U1004	8236 0859 00	V, AN, DC-DC, PQ1CF1
U1006	8236 5403 15	ST, AN, regulator, L78M15TLL-TL

Ref. No.	Part No.	Description
U1007	8236 5404 15	ST, AN, regulator, NJM79M15DLA
U1008	8236 5403 01	ST, AN, regulator, L78M05T-TL
U1009	8236 0853 00	V, AN, DC-DC, PQ1CF2

TRANSISTORS

Ref. No.	Part No.	Description
Q001, 002	8234 5055 00	VT, NPN, 2SC1627Y
Q003	8234 5054 00	VT, PNP, 2SA817AY

DIODES

Ref. No.	Part No.	Description
D001	8234 1050 00	VF, schottky, EK13
D002~005	8234 5028 00	ST, DAN202K
D006, 007	8234 7508 80	ST, zener, DZD24Y
D901	8234 5028 00	ST, DAN202K
D902	8234 7506 00	ST, RB400D
D1001	8234 1077 00	V, stack, 600VAC, 1.5A, D2SBA60
D1002	8234 5052 00	V, 600V, 1.7A, S2V60-4002
D1003	8234 1079 00	HT, 80V, 0.2A, MA171
D1004	8234 1080 00	V, 200V, 5.0A, MA649
D1005	8234 5028 00	ST, DAN202K
D1006	8234 1084 00	VT, schottky, EK03W
D1007	8234 1085 00	HT, fast recovery, D1NL40
D1009~11	8234 1085 00	HT, fast recovery, D1NL40
D1012	8234 1084 00	VT, schottky, EK03W
D1013	8234 5028 00	ST, DAN202K

RESISTORS

Ref. No.	Part No.	Description
R001	8230 5081 01	ST, R array, 100 x 4, 5%, CN1J4
R002, 003	8242 5051 02	Filter, ST, EMI, EXC3BB, 102
R004	8230 5101 03	ST, carbon, 1/15W, 10k , 5%
R005~007	8230 5101 01	ST, carbon, 1/15W, 100 , 5%
R008	8230 5101 03	ST, carbon, 1/15W, 10k , 5%
R009	8230 5105 62	ST, carbon, 1/15W, 5.6k , 5%
R010	8230 5103 32	ST, carbon, 1/15W, 3.3k , 5%
R011	8230 5102 22	ST, carbon, 1/15W, 2.2k , 5%
R012	8230 5101 01	ST, carbon, 1/15W, 100 , 5%
R013	8242 5051 02	Filter, ST, EMI, EXC3BB, 102
R014	8230 5101 05	ST, carbon, 1/15W, 1M , 5%
R015	8230 5100 00	ST, carbon, 1/15W, 0 , 5%
R016	8230 5103 31	ST, carbon, 1/15W, 330 , 5%
R017	8230 5101 05	ST, carbon, 1/15W, 1M , 5%
R018		N/A
R019	8230 5104 72	ST, carbon, 1/15W, 4.7k , 5%
R020		N/A
R021~025	8230 5101 01	ST, carbon, 1/15W, 100 , 5%
R026, 027	8230 5100 00	ST, carbon, 1/15W, 0 , 5%
R028		N/A
R029	8230 5104 72	ST, carbon, 1/15W, 4.7k , 5%
R030	8230 5101 52	ST, carbon, 1/15W, 1.5k , 5%
R031	8230 5101 01	ST, carbon, 1/15W, 100 , 5%
R032	8230 5102 24	ST, carbon, 1/15W, 220k , 5%

Ref. No.	Part No.	Description	Ref. No.	Part No.	Description
R033	8230 5101 03	ST, carbon, 1/15W, 10k ,5%	R1..451	8230 5081 01	ST, R array, 100 x 4, 5%, CN1J4
R034	8242 5051 02	Filter, ST, EMI, EXC3BB, 102	R152~352	8230 5101 01	ST, carbon, 1/15W, 100 ,5%
R035	8230 5101 01	ST, carbon, 1/15W, 100 ,5%	R901		N/A
R036	8230 5105 62	ST, carbon, 1/15W, 5.6k ,5%	R903	8242 5051 02	Filter, ST, EMI, EXC3BB, 102
R037		N/A	R904	8230 5101 01	ST, carbon, 1/15W, 100 ,5%
R038	8230 5103 31	ST, carbon, 1/15W, 330 ,5%	R906	8230 5101 01	ST, carbon, 1/15W, 100 ,5%
R039	8230 5101 03	ST, carbon, 1/15W, 10k ,5%	R907~909	8230 5081 01	ST, array, 100 x 4, 5%, CN1J4
R040	8230 5101 01	ST, carbon, 1/15W, 100 ,5%	R910	8230 5101 01	ST, carbon, 1/15W, 100 ,5%
R041	8242 5041 21	Filter, ST, EMI, EXC3BP, 121	R911, 912	8230 5101 02	ST, carbon, 1/15W, 1k ,5%
R042	8230 5101 02	ST, carbon, 1/15W, 1k ,5%	R913~915	8230 5101 03	ST, carbon, 1/15W, 10k ,5%
R043	8230 5101 01	ST, carbon, 1/15W, 100 ,5%	R916	8230 5004 73	ST, carbon, 1/10W, 47k ,5%
R044	8230 5101 01	ST, carbon, 1/15W, 100 ,5%	R917~920	8230 5101 03	ST, carbon, 1/15W, 10k ,5%
R045~048	8230 5101 03	ST, carbon, 1/15W, 10k ,5%	R921~924	8230 5081 01	ST, array, 100 x 4, 5%, CN1J4
R049	8230 5103 31	ST, carbon, 1/15W, 330 ,5%	R925		N/A
R050	8230 5101 02	ST, carbon, 1/15W, 1k ,5%	R926	8230 5100 00	ST, carbon, 1/15W, 0 ,5%
R051	8230 5101 03	ST, carbon, 1/15W, 10k ,5%	R927	8230 5101 01	ST, carbon, 1/15W, 100 ,5%
R052	8230 5101 01	ST, carbon, 1/15W, 100 ,5%	R928	8242 5051 02	Filter, ST, EMI, EXC3BB, 102
R053	8230 5102 21	ST, carbon, 1/15W, 220 ,5%	R1001		Wire, jumper, IPS-1041-4, F10
R054, 055	8230 5101 05	ST, carbon, 1/15W, 1M ,5%	R1002	8230 1251 04	H, metal, 2W, 100k ,5%, F20, RSS
R056, 057	8230 5104 73	ST, carbon, 1/15W, 47k ,5%	R1003, 04	8230 5005 69	ST, carbon, 1/10W, 5.6 ,5%
R058	8230 5103 32	ST, carbon, 1/15W, 3.3k ,5%	R1005	8230 1243 30	HT, metal, 1/2W, 33 ,5%, RSS
R059	8230 5102 21	ST, carbon, 1/15W, 220 ,5%	R1006	8230 5003 31	ST, carbon, 1/10W, 330 ,5%
R062~065	8230 5101 01	ST, carbon, 1/15W, 100 ,5%	R1007	8230 5001 03	ST, carbon, 1/10W, 10k ,5%
R066	8230 5101 52	ST, carbon, 1/15W, 1.5k ,5%	R1008	8230 5004 71	ST, carbon, 1/10W, 470 ,5%
R071	8230 5101 03	ST, carbon, 1/15W, 10k ,5%	R1009	8230 5003 93	ST, carbon, 1/10W, 39k ,5%
R072		N/A	R1010, 11	8230 5001 03	ST, carbon, 1/10W, 10k ,5%
R073	8230 5100 00	ST, carbon, 1/15W, 0 ,5%	R1012	8230 5003 02	ST, carbon, 1/10W, 3k ,5%
R074~076	8230 5102 21	ST, carbon, 1/15W, 220 ,5%	R1013	8230 5001 02	ST, carbon, 1/10W, 1k ,5%
R077	8230 5101 03	ST, carbon, 1/15W, 10k ,5%	R1017	8230 5004 73	ST, carbon, 1/10W, 47k ,5%
R078	8230 5101 01	ST, carbon, 1/15W, 100 ,5%	R1018	8230 5001 03	ST, carbon, 1/10W, 10k ,5%
R079	8242 5051 02	Filter, ST, EMI, EXC3BB, 102	R1019	8230 5003 02	ST, carbon, 1/10W, 3k ,5%
R080		N/A	R1020	8230 5001 02	ST, carbon, 1/15W, 1k ,5%
R087	8230 5101 03	ST, carbon, 1/15W, 10k ,5%			
R088		N/A			
R093, 094	8230 5101 03	ST, carbon, 1/15W, 10k ,5%			
R095, 096	8230 5101 02	ST, carbon, 1/15W, 1k ,5%			
R098, 099	8230 5101 01	ST, carbon, 1/15W, 100 ,5%			
R100	8230 5101 01	ST, carbon, 1/15W, 100 ,5%			
R1..601	8230 5103 33	ST, carbon, 1/15W, 33k ,5%			
R701,801	8230 5101 83	ST, carbon, 1/15W, 18k ,5%			
R1..602	8230 5104 72	ST, carbon, 1/15W, 4.7k ,5%			
R7..802	8230 5101 03	ST, carbon, 1/15W, 10k ,5%			
R1..803	8230 5101 03	ST, carbon, 1/15W, 10k ,5%			
R1..804	8230 5101 03	ST, carbon, 1/15W, 10k ,5%			
R1..805	8230 5103 31	ST, carbon, 1/15W, 330 ,5%			
R1..806	8230 5103 31	ST, carbon, 1/15W, 330 ,5%			
R1..807	8230 5101 04	ST, carbon, 1/15W, 100k ,5%			
R1..411	8230 5103 92	ST, carbon, 1/15W, 3.9k ,5%			
R1..412	8230 5103 92	ST, carbon, 1/15W, 3.9k ,5%			
R1..413	8230 5102 72	ST, carbon, 1/15W, 2.7k ,5%			
R1..414	8230 5102 01	ST, carbon, 1/15W, 200 ,5%			
R1..415	8230 5102 01	ST, carbon, 1/15W, 200 ,5%			
R1..416	8230 5102 72	ST, carbon, 1/15W, 2.7k ,5%			
R1..417	8230 5104 73	ST, carbon, 1/15W, 47k ,5%			
R1..418	8230 5001 01	ST, carbon, 1/10W, 100 ,5%			

CAPACITORS

ALU = Electrolytic type

CER = Ceramic type

PES = Mylar type

Ref. No.	Part No.	Description
C001	8232 1431 06	VT, ALU, 16V, 10 F, 20%, SME-VB
C002	8233 5151 04	ST, CER, 25V, 0.1 F, +80, CC11F
C003	8232 1431 06	VT, ALU, 16V, 10 F, 20%, SME-VB
C004, 005	8233 5151 04	ST, CER, 25V, 0.1 F, +80, CC11F
C006, 007	8232 1431 06	VT, ALU, 16V, 10 F, 20%, SME-VB
C008	8233 5134 71	ST, CER, 50V, 470pF, 15%, CC11R
C009~012	8233 5151 04	ST, CER, 25V, 0.1 F, +80, CC11F
C013	8232 1431 06	VT, ALU, 16V, 10 F, 20%, SME-VB
C014	8233 5131 03	ST, CER, 50V, 0.01 F, 15%, CC11R
C015, 016	8233 5123 30	ST, CER, 50V, 33pF, 5%, CC11SL
C017	8233 5131 03	ST, CER, 50V, 0.01 F, 15%, CC11R
C018	8233 5151 04	ST, CER, 25V, 0.1 F, +80, CC11F
C019, 020	8233 5131 03	ST, CER, 50V, 0.01 F, 15%, CC11R
C021	8232 1431 06	VT, ALU, 16V, 10 F, 20%, SME-VB
C022~025	8233 5131 03	ST, CER, 50V, 0.01 F, 15%, CC11R
C026	8232 1431 06	VT, ALU, 16V, 10 F, 20%, SME-VB
C027	8233 5134 71	ST, CER, 50V, 470pF, 15%, CC11R

Ref. No.	Part No.	Description	Ref. No.	Part No.	Description
C028	8233 5131 01	ST, CER, 50V, 100PF, 15%, CC11R	Cl.417	8232 1434 76	VT, ALU, 16V, 47 F, 20%, SME-VB
C029		N/A	Cl.418	8232 1434 76	VT, ALU, 16V, 47 F, 20%, SME-VB
C030	8233 5134 71	ST, CER, 50V, 470pF, 15%, CC11R	Cl.419	8233 5136 82	ST, CER, 50V, 0.0068 F, 15%, CC11R
C031, 032	8233 5122 20	ST, CER, 50V, 22PF, 5%, CC11SL	Cl.420	8233 5136 82	ST, CER, 50V, 0.0068 F, 15%, CC11R
C033, 034	8233 5131 03	ST, CER, 50V, 0.01 F, 15%, CC11R	Cl.451	8233 5151 04	ST, CER, 25V, 0.1 F, +80, CC11F
C035, 036		N/A	Cl.452	8233 5151 04	ST, CER, 25V, 0.1 F, +80, CC11F
C037~040	8233 5131 03	ST, CER, 50V, 0.01 F, 15%, CC11R	Cl.453	8233 5151 04	ST, CER, 25V, 0.1 F, +80, CC11F
C041~045		N/A	Cl.454	8233 5151 04	ST, CER, 25V, 0.1 F, +80, CC11F
C046	8232 1431 06	VT, ALU, 16V, 10 F, 20%, SME-VB	Cl.457	8232 1431 06	VT, ALU, 16V, 10 F, 20%, SME-VB
C047	8233 5151 04	ST, CER, 25V, 0.1 F, +80, CC11F	Cl.458	8233 5151 04	ST, CER, 25V, 0.1 F, +80, CC11F
C048	8232 1431 06	VT, ALU, 16V, 10 F, 20%, SME-VB	Cl.459	8232 1431 06	VT, ALU, 16V, 10 F, 20%, SME-VB
C049~051	8233 5131 03	ST, CER, 50V, 0.01 F, 15%, CC11R	Cl.461	8233 5151 04	ST, CER, 25V, 0.1 F, +80, CC11F
C052	8233 5121 50	ST, CER, 50V, 15pF, 5%, CC11SL	Cl.462	8233 5151 04	ST, CER, 25V, 0.1 F, +80, CC11F
C053~057	8233 5131 03	ST, CER, 50V, 0.01 F, 15%, CC11R	Cl.463	8233 5151 04	ST, CER, 25V, 0.1 F, +80, CC11F
C058	8233 5164 74	ST, CER, 16V, 0.47 F, 20%, KC20E	Cl.464	8233 5151 04	ST, CER, 25V, 0.1 F, +80, CC11F
C059	8232 1431 06	VT, ALU, 16V, 10 F, 20%, SME-VB	Cl.465	8232 1431 06	VT, ALU, 16V, 10 F, 20%, SME-VB
C060	8233 5151 04	ST, CER, 25V, 0.1 F, +80, CC11F	C901	8232 1431 07	VT, ALU, 16V, 100 F, 20%, SME-VB
C061, 062	8233 5131 03	ST, CER, 50V, 0.01 F, 15%, CC11R	C902, 903	8233 5131 03	ST, CER, 50V, 0.01 F, 15%, CC11R
C063	8232 1431 06	VT, ALU, 16V, 10 F, 20%, SME-VB	C904	8232 3711 87	VT, ALU, 16V, 180 F, 20%, LXV, D6.3
C064	8233 5121 50	ST, CER, 50V, 15PF, 5%, CC11SL	C905	8233 5151 04	ST, CER, 25V, 0.1 F, +80, CC11F
C065	8233 5164 74	ST, CER, 16V, 0.47 F, 20%, KC20E	C906	8233 5131 03	ST, CER, 50V, 0.01 F, 15%, CC11R
C066, 067	8233 5131 03	ST, CER, 50V, 0.01 F, 15%, CC11R	C907	8233 5151 04	ST, CER, 25V, 0.1 F, +80, CC11F
C068~070	8233 5151 04	ST, CER, 25V, 0.1 F, +80, CC11F	C908~911	8233 5131 03	ST, CER, 50V, 0.01 F, 15%, CC11R
C071	8233 5131 03	ST, CER, 50V, 0.01 F, 15%, CC11R	C912	8232 1431 06	VT, ALU, 16V, 10 F, 20%, SME-VB
C072	8232 1461 05	VT, ALU, 50V, 1 F, 20%, SME-VB	C913, 914	8232 1434 76	VT, ALU, 16V, 47 F, 20%, SME-VB
C073	8233 5131 03	ST, CER, 50V, 0.01 F, 15%, CC11R	C915~919	8233 5134 71	ST, CER, 50V, 470pF, 15%, CC11R
C074, 075	8233 5123 30	ST, CER, 50V, 33pF, 5%, CC11SL	C920, 921	8232 3824 76	VT, ALU, 63V, 47 F, 20%, LXV, D8
C076	8233 5131 03	ST, CER, 50V, 0.01 F, 15%, CC11R	C922	8232 3711 87	VT, ALU, 16V, 180 F, 20%, LXV, D6.3
C077	8233 5131 01	ST, CER, 50V, 100pF, 15%, CC11R	C923	8233 5131 03	ST, CER, 50V, 0.01 F, 15%, CC11R
C078	8233 5134 71	ST, CER, 50V, 470pF, 15%, CC11R	C925~928	8233 5131 03	ST, CER, 50V, 0.01 F, 15%, CC11R
C079		N/A	C929		N/A
C080	8233 5131 03	ST, CER, 50V, 0.01 F, 15%, CC11R	C930	8233 5134 71	ST, CER, 50V, 470pF, 15%, CC11R
C081		N/A	C931~934	8233 5131 03	ST, CER, 50V, 0.01 F, 15%, CC11R
C082~087	8233 5131 03	ST, CER, 50V, 0.01 F, 15%, CC11R	C935	8233 5134 71	ST, CER, 50V, 470pF, 15%, CC11R
C088, 089	8233 5151 04	ST, CER, 25V, 0.1 F, +80, CC11F	C936		N/A
C090	8233 5131 03	ST, CER, 50V, 0.01 F, 15%, CC11R	C939~943	8233 5131 03	ST, CER, 50V, 0.01 F, 15%, CC11R
C091	8232 1431 06	VT, ALU, 16V, 10 F, 20%, SME-VB	C945~952		N/A
C092	8233 5122 20	ST, CER, 50V, 22pF, 5%, CC11SL	C1001	8232 3521 04	V, PES, 250VAC, 0.1 F, 20%, ECQ-UMV
C093	8233 5131 03	ST, CER, 50V, 0.01 F, 15%, CC11R	C1002, 03	8232 3542 22	VT, CER, 250V, 0.0022 F, 20%, ECK-ZNS
C094	8233 5134 71	ST, CER, 50V, 470pF, 15%, CC11R	C1004	8232 3241 07	V, ALU, 400V, 100 F, 20%, SMH-VNSN, D25.4
C095	8233 5131 01	ST, CER, 50V, 100pF, 15%, CC11R	C1005	8232 3491 03	VT, PES, 630V, 0.01 F, 10%, ECQ-EKF3
C096~098	8233 5131 03	ST, CER, 50V, 0.01 F, 15%, CC11R	C1006	8233 5151 04	ST, CER, 25V, 0.1 F, +80, CC11F
C099		N/A	C1007	8232 1434 76	VT, ALU, 16V, 47 F, 20%, SME-VB
C100	8233 5131 03	ST, CER, 50V, 0.01 F, 15%, CC11R	C1008	8233 5151 04	ST, CER, 25V, 0.1 F, +80, CC11F
Cl..801	8232 1431 06	VT, ALU, 16V, 10 F, 20%, SME-VB	C1009, 10	8232 3542 22	VT, CER, 250V, 0.0022 F, 20%, ECK-ZNS
Cl..802	8233 5131 52	ST, CER, 50V, 0.0015 F, 15%, CC11R	C1011	8232 3574 77	VT, ALU, 16V, 470 F, 20%, LXV, D10
Cl..803	8233 5131 03	ST, CER, 50V, 0.01 F, 15%, CC11R	C1012	8232 3533 91	VT, CER, 500V, 390pF, 10%, ECK-ZHT
Cl..804	8233 5131 03	ST, CER, 50V, 0.01 F, 15%, CC11R	C1013	8233 5151 04	ST, CER, 25V, 0.1 F, +80, CC11F
Cl..806		N/A	C1014	8232 1431 06	VT, ALU, 16V, 10 F, 20%, SME-VB
Cl..807		N/A	C1015, 16	8232 3574 77	VT, ALU, 16V, 470 F, 20%, LXV, D10
Cl..412	8233 5138 21	ST, CER, 50V, 820pF, 15%, CC11R			
Cl..413	8233 5138 21	ST, CER, 50V, 820pF, 15%, CC11R			
Cl..414	8232 1431 07	VT, ALU, 16V, 100 F, 20%, SME-VB			
C115, 315	8233 5131 03	ST, CER, 50V, 0.01 F, 15%, CC11R			
C116, 316	8233 5131 03	ST, CER, 50V, 0.01 F, 15%, CC11R			

Ref. No.	Part No.	Description
C1017, 18	8232 3584 77	VT, ALU, 25V, 470 F, 20%, LXV, D10
C1019, 20	8233 5151 04	ST, CER, 25V, 0.1 F, +80, CC11F
C1021, 22	8232 3711 87	VT, ALU, 16V, 180 F, 20%, LXV, D6.3
C1023	8232 3824 76	VT, ALU, 63V, 47 F, 20%, LXV, D8
C1026	8232 3584 77	VT, ALU, 25V, 470 F, 20%, LXV, D10
C1028	8232 3574 77	VT, ALU, 16V, 470 F, 20%, LXV, D10
C1029	8233 5151 04	ST, CER, 25V, 0.1 F, +80, CC11F
C1030	8232 3711 87	VT, ALU, 16V, 180 F, 20%, LXV, D6.3

MISCELLANEOUS

Ref. No.	Part No.	Description
E1801		N/A (TP001)
E1802		N/A (TP002)
E1803		N/A (TP003)
E1804		N/A (TP004)
E1805		N/A (TP005)
E1806	8276 0010 00	Pin, header, TP006
E1807	8276 0010 00	Pin, header, TP007
△ F1001	8239 8010 08	Fuse, VT, SEMKO, TLAG, 0.8A, 250V, TR5-T
J001	8245 1711 09	Connector, PI, jack, 8283, 9P, WHT
J002	8245 1711 10	Connector, PI, jack, 8283, 10P, WHT
J003	8245 5530 10	Connector, opt, GPIF37R1
J004	8245 5520 10	Connector, opt, GPIF38T2
J005	8245 3220 50	Connector, PI, header, 50P, P2.0, 9210B
J006	8245 3290 50	Connector, PL, D-SUB, 50P, P1.27, ECI2
J008	8245 3390 04	Connector, PL, jack, phone, YKB21-5074
J009	8245 4200 00	Connector, PL, jack, DIN5P (shield), YKF51-5053
J012	8277 4770 30	Cable assy, FC, 40P/F-/B, L300, reverse
J901	8245 2720 17	Connector, PI, jack, FPC 17P
J902	8245 3390 04	Connector, PL, jack, phone, YKB21-5074
J903	8245 3130 01	Connector, PL, jack, RCA, 2P, BLK, W/S
J1001	8245 3210 00	Connector, PL, jack, AC inlet, 3P, 0714-FR7
L001, 002	8242 5025 60	Core, ST, CDRH104, 56
L003, 004	8242 1962 23	Coil, PVT, 22 H, 5%, LF5.0S
L005	8242 5041 21	Filter, ST, EMI, EXC3BP, 121
L006	8242 1962 23	Coil, PVT, 22 H, 5%, LF5.0S
L007	8242 5041 21	Filter, ST, EMI, EXC3BP, 121
L017~021	8242 5041 21	Filter, ST, EMI, EXC3BP, 121
L101~801	8242 5041 21	Filter, ST, EMI, EXC3BP, 121
L102~402	8242 5041 21	Filter, ST, EMI, EXC3BP, 121
L901	8242 5041 21	Filter, ST, EMI, EXC3BP, 121
L903~907	8242 5041 21	Filter, ST, EMI, EXC3BP, 121
L1001, 02	8242 1340 01	Filter, EMI, 6 hole
L1003	8242 2491 02	Filter, line, 1mH, 2.2A, ELFI5NO22A
L1004	8242 2741 83	Filter, line, 18mH, 0.5A, ELF18D210
L1005	8242 2501 03	Coil, PV, 10 H, 2A, ELC
L1006, 07	8242 2640 01	Coil, DC-DC, R17, 256
S1001	8253 4610 02	SW, P, push, power, SDDL1B1-B1-F2
T1001	8242 2720 00	Transformer, SW POWER, ER2810, D12-A15-A53

Ref. No.	Part No.	Description
W001		N/A
W901		N/A
W902	8230 5100 00	Resistor, ST, carbon, 1/15W, 0, 5%
W1001	8277 1630 15	Cable assy, earth lug - SIN1.8, L150
W1002	8277 3184 20	Cable assy, 4P, 5395-CNC, L200
X001	8256 1700 01	Resonator, ST, XTL, 22.579MHZ, FUP-FBB3A
X003	8256 1790 02	Resonator, PT, CER, 8MHz, EFOEN
X004	8256 1710 01	Resonator, PT, CER, 20.00MHz, KBR
Y4201	8207 0015 00	Heat sink, OSH-1625-SP

• Key PCB assy

Ref. No.	Part No.	Description
	8274 2550 00	PCB Assy, Key, VF-16
	8251 9662 01	Plain PCB, Key, VF-16

ICs

Ref. No.	Part No.	Description
U001	8236 0869 00	QFP, DG, CPU, VF-16 KEY, H8/3217ZTAT
U002	8236 5600 14	ST, DG, 74HC14
U004	8256 1870 00	Module, jog, SRGPWJ
U006	8236 5600 74	ST, DG, 74HC74
U007	8236 5601 38	ST, DG, 74HC138
U008		N/A
U009	8236 0846 10	TSOP, DG, SRAM, LC361000ATLL-70-TLM
U010	8236 5600 10	ST, DG, 74HC10
U011	8236 5601 38	ST, DG, 74HC138
U012, 013	8236 5600 32	ST, DG, 74HC32
U021~028	8236 5056 00	ST, DG, driver, DTD113ZK
U051, 052	8236 5630 52	ST, DG, 74HC4052

TRANSISTORS

Ref. No.	Part No.	Description
Q001~008	8234 1008 02	VT, PNP, 2SA1150Y

DIODEs

Ref. No.	Part No.	Description
D001~003		N/A
D004~048	8234 5007 00	HT, ISS136
D049~051		N/A
D052~058	8234 5007 00	HT, ISS136
D059~064		N/A
D071, 072	8234 5040 01	Opt, VT, LED, red, LT3D31W
D073	8234 5040 04	Opt, VT, LED, gm, LT3E31W
D074	8234 5040 03	Opt, VT, LED, ylw, LT3H31W
D075	8234 5040 01	Opt, VT, LED, red, LT3D31W
D076	8234 5040 04	Opt, VT, LED, gm, LT3E31W
D077	8234 5040 01	Opt, VT, LED, red, LT3D31W
D078	8234 5040 04	Opt, VT, LED, gm, LT3E31W
D079		N/A

Ref. No.	Part No.	Description
D080, 081	8234 5040 04	Opt, VT, LED, grn, LT3E31W
D082	8234 5040 01	Opt, VT, LED, red, LT3D31W
D083~086	8234 5040 03	Opt, VT, LED, ylw, LT3H31W
D087		N/A
D088, 089	8234 5040 03	Opt, VT, LED, ylw, LT3H31W
D090	8234 5040 04	Opt, VT, LED, grn, LT3E31W
D091	8234 5040 03	Opt, VT, LED, ylw, LT3H31W
D092	8234 5040 01	Opt, VT, LED, red, LT3D31W
D093, 094	8234 5040 03	Opt, VT, LED, ylw, LT3H31W
D095~097		N/A
D098	8234 5040 04	Opt, VT, LED, grn, LT3E31W
D099	8234 5040 01	Opt, VT, LED, red, LT3D31W
D100	8234 5040 03	Opt, VT, LED, ylw, LT3H31W
D101	8234 5040 04	Opt, VT, LED, grn, LT3E31W
D102	8234 5040 03	Opt, VT, LED, ylw, LT3H31W
D103~105		N/A
D106~110	8234 5058 00	Opt, VT, LED, grn-red, SPR-325MVW
D111~113		N/A
D114~118	8234 5058 00	Opt, VT, LED, grn-red, SPR-325MVW

RESISTORS

Ref. No.	Part No.	Description
R001		N/A
R002	8230 5101 03	ST, carbon, 1/15W, 10k , 5%
R003~008	8230 5101 01	ST, carbon, 1/15W, 100 , 5%
R009		N/A
R010, 011	8230 5101 03	ST, carbon, 1/15W, 10k , 5%
R012~015	8230 5101 04	ST, carbon, 1/15W, 100k , 5%
R016	8240 2930 08	Pot, PI, RT09, 500k B, EVUF2A, 25
R017	8230 5101 01	ST, carbon, 1/15W, 100 , 5%
R018	8230 5104 73	ST, carbon, 1/15W, 47k , 5%
R019		N/A
R020~027	8230 5104 73	ST, carbon, 1/15W, 47k , 5%
R031~038	8230 1381 01	HT, carbon, 1/4W, 100 , 5%
R039~046	8230 5101 02	ST, carbon, 1/15W, 1k , 5%
R054~059	8240 2960 01	Slide VR, EWAQF X05, 10k
R064~068	8240 2960 01	Slide VR, EWAQF X05, 10k

CAPACITORS

ALU = Electrolytic type

CER = Ceramic type

Ref. No.	Part No.	Description
C001	8233 5131 03	ST, CER, 50V, 0.01 F, 15%, CC11R
C002		N/A
C003	8233 5131 03	ST, CER, 50V, 0.01 F, 15%, CC11R
C004	8233 5134 71	ST, CER, 50V, 470pF, 15%, CC11R
C005	8232 1431 06	VT, ALU, 16V, 10 F, 20%, SME-VB
C006	8233 5134 71	ST, CER, 50V, 470pF, 15%, CC11R
C007, 008	8233 5123 00	ST, CER, 50V, 30pF, 5%, CC11SL
C009	8233 5134 71	ST, CER, 50V, 470pF, 15%, CC11R
C010, 011		N/A
C012	8233 5131 03	ST, CER, 50V, 0.01 F, 15%, CC11R
C013		N/A
C014, 015	8233 5131 03	ST, CER, 50V, 0.01 F, 15%, CC11R
C016	8233 5134 71	ST, CER, 50V, 470pF, 15%, CC11R

Ref. No.	Part No.	Description
C017~023	8233 5131 03	ST, CER, 50V, 0.01 F, 15%, CC11R
C051	8232 1431 06	VT, ALU, 16V, 10 F, 20%, SME-VB
C052~059	8233 5131 03	ST, CER, 50V, 0.01 F, 15%, CC11R
C305~308	8233 5151 04	ST, CER, 25V, 0.1 F, +80, CC11F

MISCELLANEOUS

Ref. No.	Part No.	Description
E0901, 02		N/A
E0903		Jumper, F5.0
E0904		Jumper, F7.5
E0905		Jumper, F10.0
E0906		Jumper, F12.5
E0907		Jumper, F15.0
E0908		Jumper, F20.0
E0909		Jumper, F25.0
E0910		Jumper, F30.0
J001		N/A
J002	8245 3220 20	Connector, PI , header, 20P, P2.0, 9210B
J010, 011	8245 3600 12	Connector, PL, socket, 12P, 9110S-12L
L001, 002	8239 1160 00	Lamp, 5V, 75mA
L003, 004		N/A
L005~007	8242 5041 21	Filter, ST, EMI, EXC3BP,121
S001~003		N/A
S004~048	8253 1350 02	SW, PT, tact, SKQNAB
S049~051		N/A
S052~058	8253 1350 02	SW, PT, tact, SKQNAB
S059~064		N/A
W001	8276 7790 50	Cable assy, 9P, WHTMT/F-MT/BS, L500
W002	8276 7800 35	Cable assy, 10P, WHTMT/F-MT/BS, L350
X001	8256 5004 01	Resonator, PT, CER, 16.00MHZ, CSA

• LCD assy

Ref. No.	Part No.	Description
	8260 5740 00	Assy, LCD, VF-16

Ref. No.	Part No.	Description
A101	8260 5750 00	LCD module, 128 x 64
A102	8274 2560 00	PCB assy, LCD, VF-16

• LCD Module

Ref. No.	Part No.	Description
	8260 5750 00	Module, LCD, VF-16

Ref. No.	Part No.	Description
E101	8256 1860 00	Display, LCD, 128 x 64
E102	8236 0856 00	IC, TCP, driver, T6K04
Y101	8216 6961 00	ACF, AC-7104, 2 x 55mm
A101	8260 5750 50	LD sub module, 128 x 64

• LCD PCB assy

Ref. No.	Part No.	Description
	8274 2560 00	PCB Assy, LCD, VF-16
	8251 9922 01	Plain PCB, LCD, VF-16

Ref. No.	Part No.	Description
R001	8230 5107 53	Resistor, ST, carbon, 1/15W, 75k , 5%
R002		N/A
C001		N/A
C002	8232 1431 06	Capacitor, VT, ALU, 16V, 10 F, 20%, SME-VB
C003	8233 5131 03	Capacitor, ST, CER, 50V, 0.01 F, 15%, CC11R
C004	8232 1462 25	Capacitor, VT, ALU, 50V, 2.2 F, 20%, SME-VB
C005-009	8232 1461 05	Capacitor, VT, ALU, 50V, 1 F, 20%, SME-VB
C010-012	8232 1462 25	Capacitor, VT, ALU, 50V, 2.2 F, 20%, SME-VB
J001	8245 3230 20	Connector, PI, socket, 20P, P2.0, 9269S-B

• MIC/MON PCB assy

Ref. No.	Part No.	Description
	8274 2530 00	PCB Assy, MIC/MON, VF-16
	8251 9973 01	Plain PCB, MIC/MON, VF-16

ICs

Ref. No.	Part No.	Description
U001-004	8236 5405 00	SOP, AN, NJM2068MD (TEI)
U005	8236 5412 00	ST, AN, op amp, NJM4565M
U006	8236 7205 00	ST, AN, NJM4556AM
U130, 230	8236 5702 01	ST, DG, driver, DTC314TK
U161-861	8236 5704 01	ST, DG, driver, DTA114EK

TRANSISTORS

Ref. No.	Part No.	Description
Q161-861	8234 6003 05	ST, NPN, 2SC2412KR/S

DIODES

Ref. No.	Part No.	Description
D701, 801	8234 5028 00	ST, DAN202K
D702, 802	8234 5029 00	ST, DAP202K-T146

RESISTORS

Ref. No.	Part No.	Description
R001, 002	8240 2940 02	Pot, PI, RT12, 10k AA, EVJY15
R005, 006	8230 5034 79	ST, carbon, 1/2W, 4.7 , 5%
R101-601	8230 5101 04	ST, carbon, 1/15W, 100k , 5%
R102-602	8230 5101 04	ST, carbon, 1/15W, 100k , 5%
R103-603	8230 5103 90	ST, carbon, 1/15W, 39 , 5%
R104-604	8230 5101 01	ST, carbon, 1/15W, 100 , 5%
R105-605		N/A
R120-620	8240 2930 05	Pot, PI, RT09, 20k C, EVUF2L
R701, 801	8230 5126 82	ST, carbon, 1/4W, 6.8k , 1%

Ref. No.	Part No.	Description
R702, 802	8230 5126 82	ST, carbon, 1/4W, 6.8k , 1%
R703, 803	8230 5101 04	ST, carbon, 1/15W, 100k , 5%
R704, 804	8230 5101 04	ST, carbon, 1/15W, 100k , 5%
R705, 805	8230 5101 04	ST, carbon, 1/15W, 100k , 5%
R706, 806	8230 5101 02	ST, carbon, 1/15W, 1k , 5%
R707, 807	8230 5101 02	ST, carbon, 1/15W, 1k , 5%
R708, 808	8230 5101 04	ST, carbon, 1/15W, 100k , 5%
R709, 809	8230 5101 04	ST, carbon, 1/15W, 100k , 5%
R710, 810	8230 5101 04	ST, carbon, 1/15W, 100k , 5%
R711, 811	8230 5101 01	ST, carbon, 1/15W, 100 , 5%
R712, 812	8230 5101 04	ST, carbon, 1/15W, 100k , 5%
R713, 813	8230 5101 04	ST, carbon, 1/15W, 100k , 5%
R720, 820	8240 2940 04	Pot, PI, RT12, 500k CC, EVJY95
R130, 230	8230 5101 04	ST, carbon, 1/15W, 100k , 5%
R131, 231	8230 5101 03	ST, carbon, 1/15W, 10k , 5%
R132, 232	8230 5101 03	ST, carbon, 1/15W, 10k , 5%
R133, 233	8230 5101 03	ST, carbon, 1/15W, 10k , 5%
R134, 234	8230 5101 02	ST, carbon, 1/15W, 1k , 5%
R150, 250	8230 5101 04	ST, carbon, 1/15W, 100k , 5%
R151, 251	8230 5101 03	ST, carbon, 1/15W, 10k , 5%
R151, 252	8230 5101 04	ST, carbon, 1/15W, 100k , 5%
R153, 253	8230 5101 03	ST, carbon, 1/15W, 10k , 5%
R154, 254	8230 5035 60	ST, carbon, 1/2W, 56 , 5%
R161-661	8230 5102 73	ST, carbon, 1/15W, 27k , 5%
R761, 861	8230 5101 33	ST, carbon, 1/15W, 13k , 5%
R162-662	8230 5103 32	ST, carbon, 1/15W, 3.3k , 5%
R762, 862	8230 5101 03	ST, carbon, 1/15W, 10k , 5%
R163-663	8230 5104 74	ST, carbon, 1/15W, 470k , 5%
R763, 863	8230 5101 05	ST, carbon, 1/15W, 1M , 5%
R164-864	8230 5022 02	ST, carbon, 1/4W, 2k , 5%

CAPACITORS

ALU = Electrolytic type

CER = Ceramic type

Ref. No.	Part No.	Description
C001-010	8233 5131 03	ST, CER, 50V, 0.01 F, 15%, CC11R
C011, 012	8232 1432 27	VT, ALU, 16V, 220 F, 20%, SME-VB
C015		N/A
C101-601	8232 1431 06	VT, ALU, 16V, 10 F, 20%, SME-VB
C102-602		N/A
C103-603	8233 5122 20	ST, CER, 50V, 22pF, 5%, CC11SL
C104-604	8233 5122 20	ST, CER, 50V, 22pF, 5%, CC11SL
C105-605	8232 1421 07	VT, ALU, 10V, 100 F, 20%, SME-VB
C106-606	8232 1424 76	VT, ALU, 10V, 47 F, 20%, SME-VB
C701, 801	8233 5131 03	ST, CER, 50V, 0.01 F, 15%, CC11R
C702, 802	8232 2964 76	VT, ALU, 50V, 47 F, 20%, LLA
C703, 803	8232 2964 76	VT, ALU, 50V, 47 F, 20%, LLA
C704, 804	8232 1504 76	VT, ALU, 16V, 47 F, 20%, SME-VP-BP
C705, 805	8232 1504 76	VT, ALU, 16V, 47 F, 20%, SME-VP-BP
C706, 806		N/A
C707, 807	8233 5122 20	ST, CER, 50V, 22pF, 5%, CC11SL
C708, 808	8233 5122 20	ST, CER, 50V, 22pF, 5%, CC11SL
C709, 809	8232 1431 06	VT, ALU, 16V, 10 F, 20%, SME-VB
C710, 810	8232 1431 06	VT, ALU, 16V, 10 F, 20%, SME-VB
C711, 811	8232 1431 06	VT, ALU, 16V, 10 F, 20%, SME-VB

Ref. No.	Part No.	Description
C712, 812	8233 5131 01	ST, CER, 50V, 100pF, 15%, CC11R
C130, 230	8232 1431 06	VT, ALU, 16V, 10 F, 20%, SME-VB
C131, 231		N/A
C132, 232	8233 5122 20	ST, CER, 50V, 22pF, 5%, CC11SL
C133, 233	8232 1431 06	VT, ALU, 16V, 10 F, 20%, SME-VB
C151, 251		N/A
C152, 252	8233 5122 20	ST, CER, 50V, 22pF, 5%, CC11SL
C153, 253	8232 1432 27	VT, ALU, 16V, 220 F, 20%, SME-VB
C161~861	8233 5164 74	ST, CER, 16V, 0.47 F, 20%, KC20E

MISCELLANEOUS

Ref. No.	Part No.	Description
J001	8245 2721 17	Connector, PL, jack, FPC, 17P
J002	8245 3570 00	Connector, PI, jack, phone, NY234
J003	8245 1721 09	Connector, PL, jack, 8283, 9P, WHT
J101~801	8245 3570 00	Connector, PI, jack, phone, NY234
J702, 802	8245 3570 00	Connector, PI, jack, phone, NY234
J703, 803	8245 2680 00	Connector, PI, jack, XLR31, 3P, NC3FAV1-0
J130, 230	8245 3570 00	Connector, PI, jack, phone, NY234
L101~801	8242 5041 21	Filter, ST, EMI, EXC3BP, 121
L702, 802	8242 5041 21	Filter, ST, EMI, EXC3BP, 121
L703, 803	8242 5041 21	Filter, ST, EMI, EXC3BP, 121
L130, 230	8242 5041 21	Filter, ST, EMI, EXC3BP, 121
L150, 250	8242 5041 21	Filter, ST, EMI, EXC3BP, 121

• PEAK LED PCB assy

Ref. No.	Part No.	Description
	8274 2770 00	PCB Assy, Peak LED, VF-16
	8251 9962 02	Plain PCB, Peak LED, VF-16

Ref. No.	Part No.	Description
D201~208	8234 1046 01	Diode, opt, LED, red, SLR-332VC-TE7
E001		N/A
W201	8276 7790 20	Cable assy, 9P, WHTMT/F-MT/BS, L200

• KEY2 PCB assy

Ref. No.	Part No.	Description
	8274 2790 00	PCB Assy, Key2, VF-16
	8251 7050 00	Plain PCB, Key2, VF-16

DIODEs

Ref. No.	Part No.	Description
D001~003	8234 5007 00	HT, 1SS136
D049~051	8234 5007 00	HT, 1SS136
D103~105	8234 5058 00	Opt, VT, LED, gm-red, SPR-325MVW
D111~113	8234 5058 00	Opt, VT, LED, gm-red, SPR-325MVW

RESISTORs

Ref. No.	Part No.	Description
R051~053	8240 2960 01	Slide VR, EWAQF X05, 10k
R061~063	8240 2960 01	Slide VR, EWAQF X05, 10k

MISCELLANEOUS

Ref. No.	Part No.	Description
E0201		Jumper, F5.0
E0202		Jumper, F7.5
E0203		Jumper, F10.0
J010, 011	8245 3610 12	Connector, PL, header, 12P, 9176B-12L
S001~003	8253 1350 02	SW, PT, tact, SOR-112HS
S049~051	8253 1350 02	SW, PT, tact, SOR-112HS

● Abbreviation

S:	Surface mount
V:	Vertical mount
P:	Penetrate mount
T:	Taping device
F:	Forming device
L:	L form
I:	I form
SOJ:	Small Outline package with J leads
QFP:	Quad Flat Package
SOP:	Small Outline Package
TSOP:	Thin Small Outline Package
TSSOP:	Thin Shrink Small Outline Package
DIP:	Dual In-line Package
220:	TO-220 type
DG:	Digital
AN:	Analog

7. CIRCUIT & BLOCK DIAGRAMS

● ROOT, MAIN PCB, VF-16

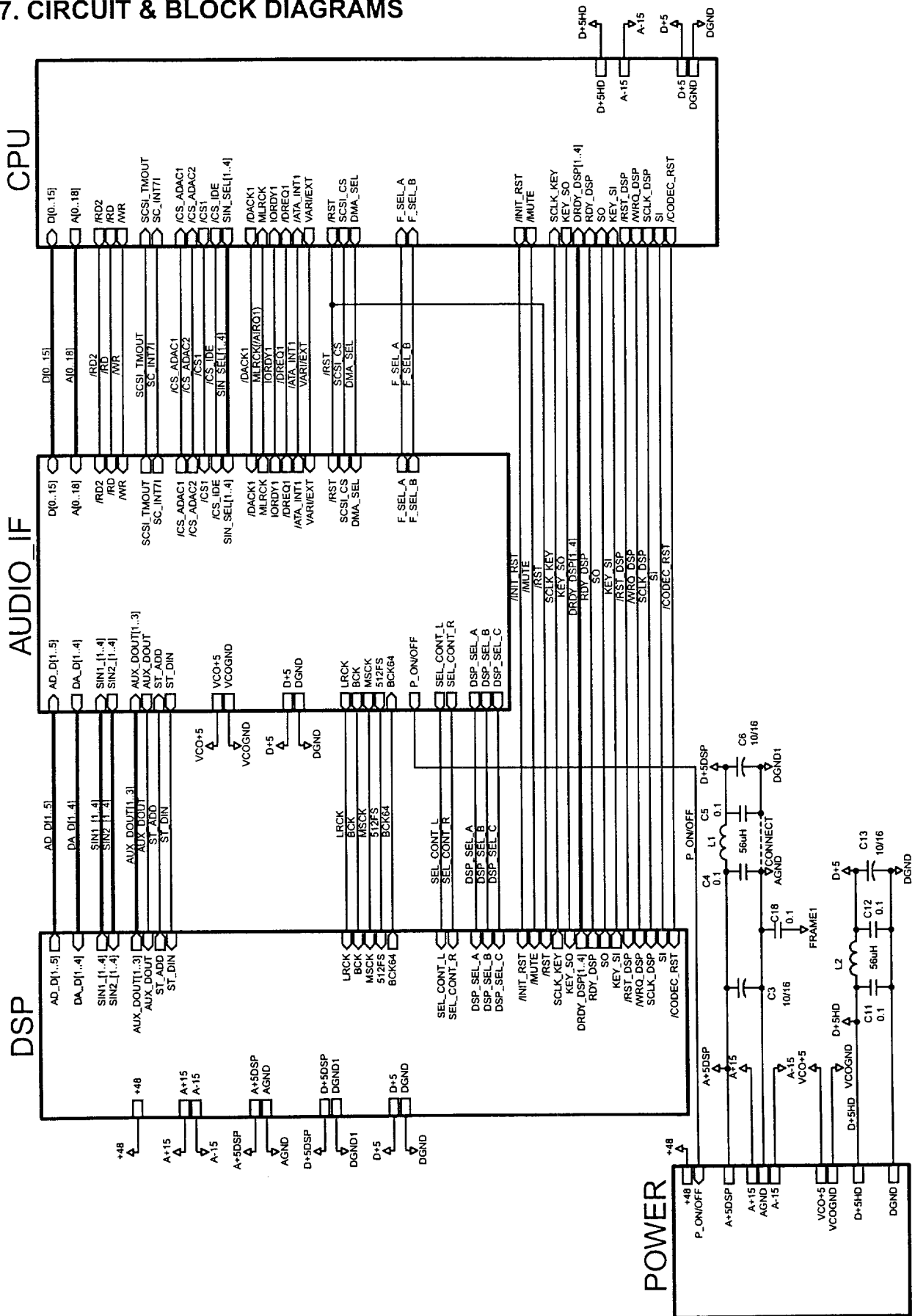

● CPU, MAIN PCB, VF-16

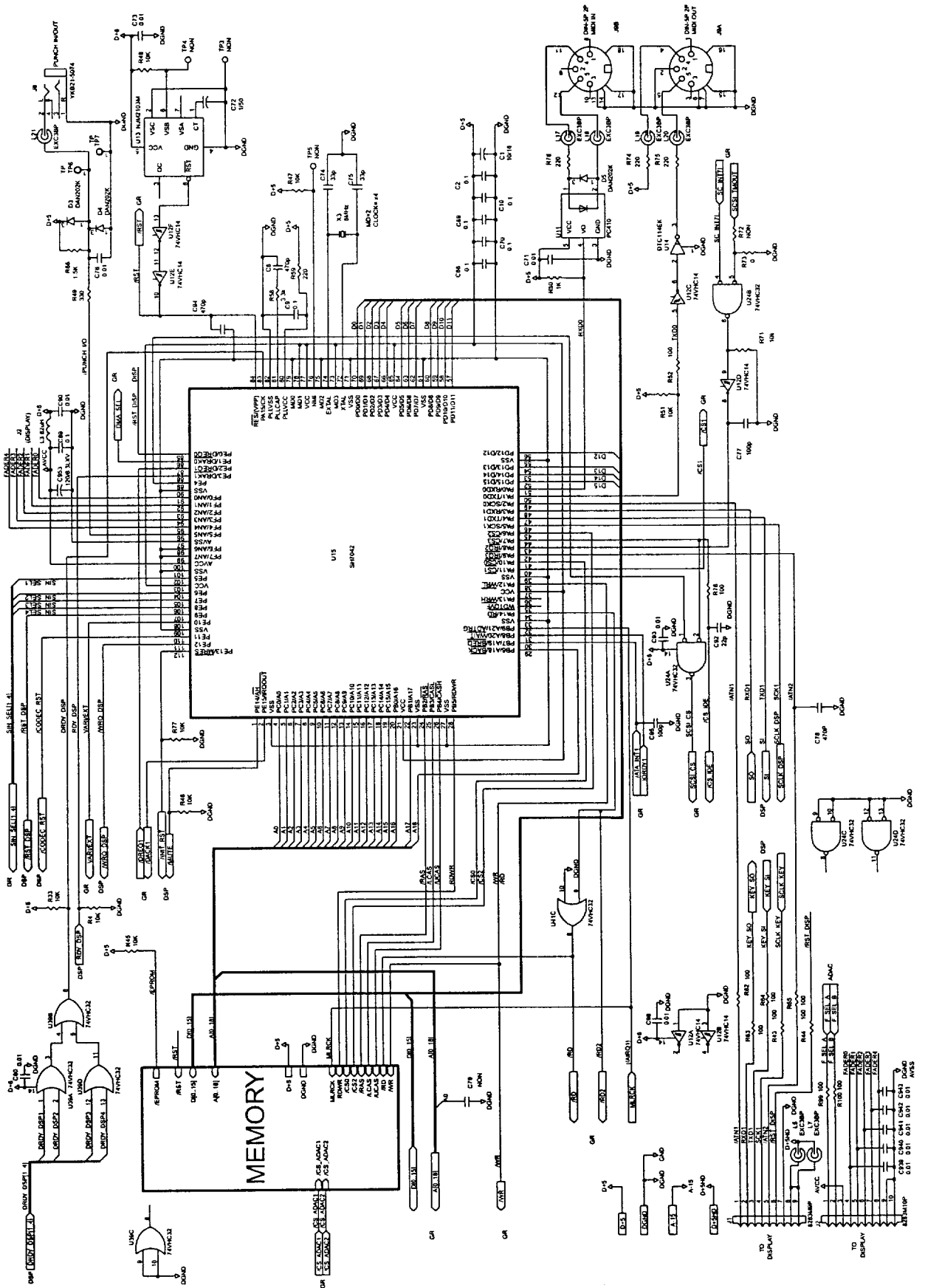

● MEMORY, MAIN PCB, VF-16

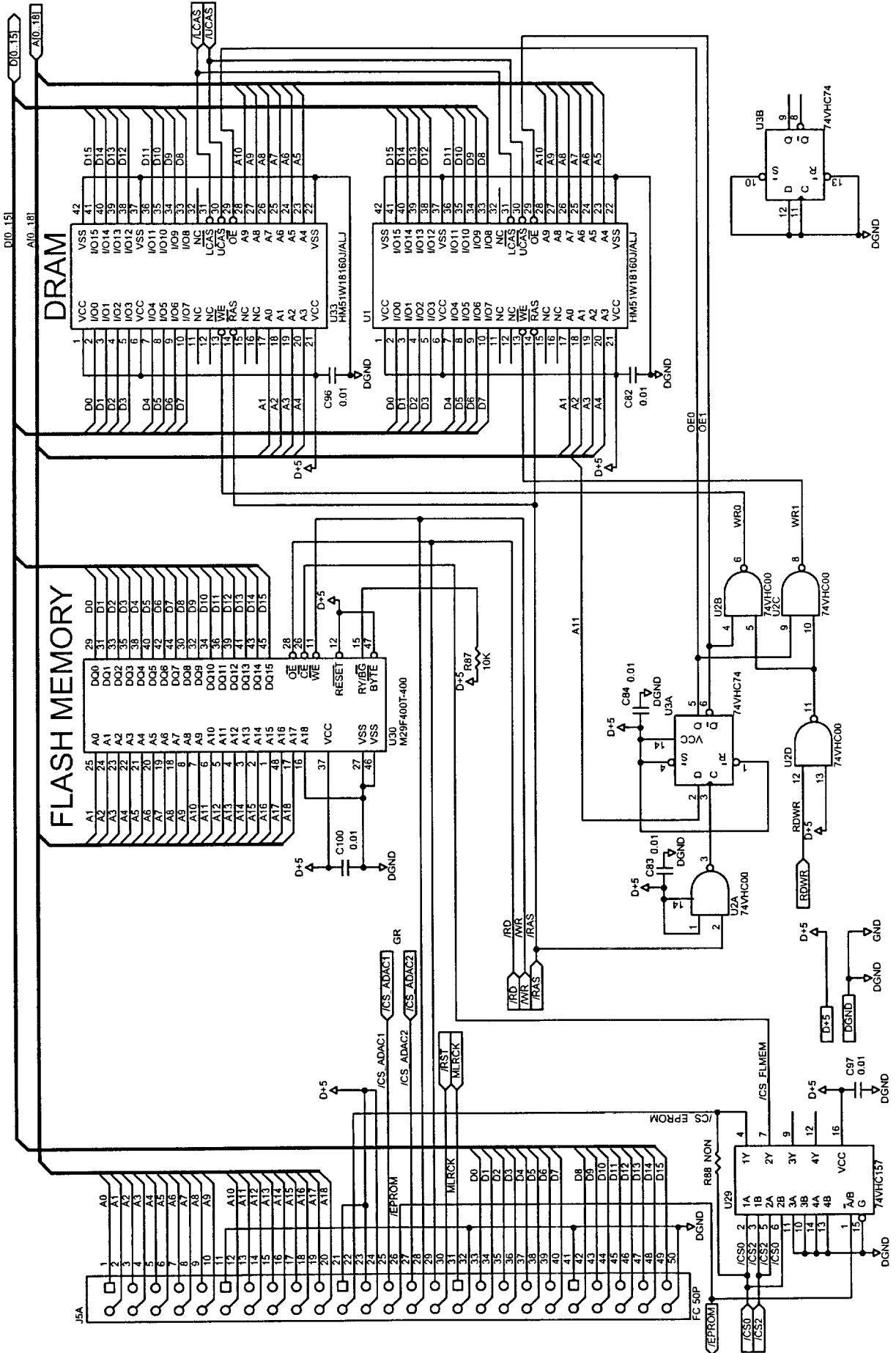

● VCO, MAIN PCB, VF-16

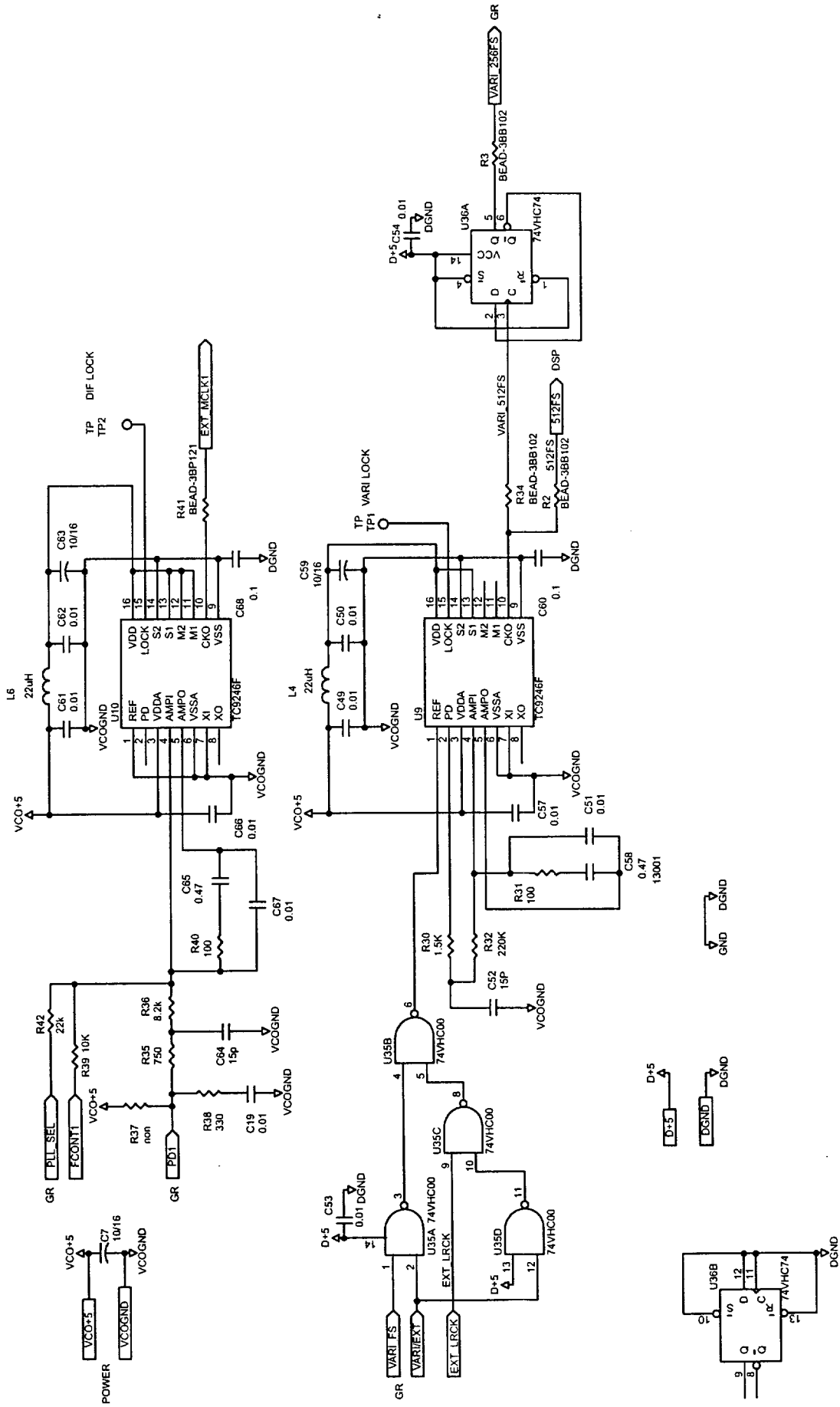

● ROOT, DSP, MAIN PCB, VF-16

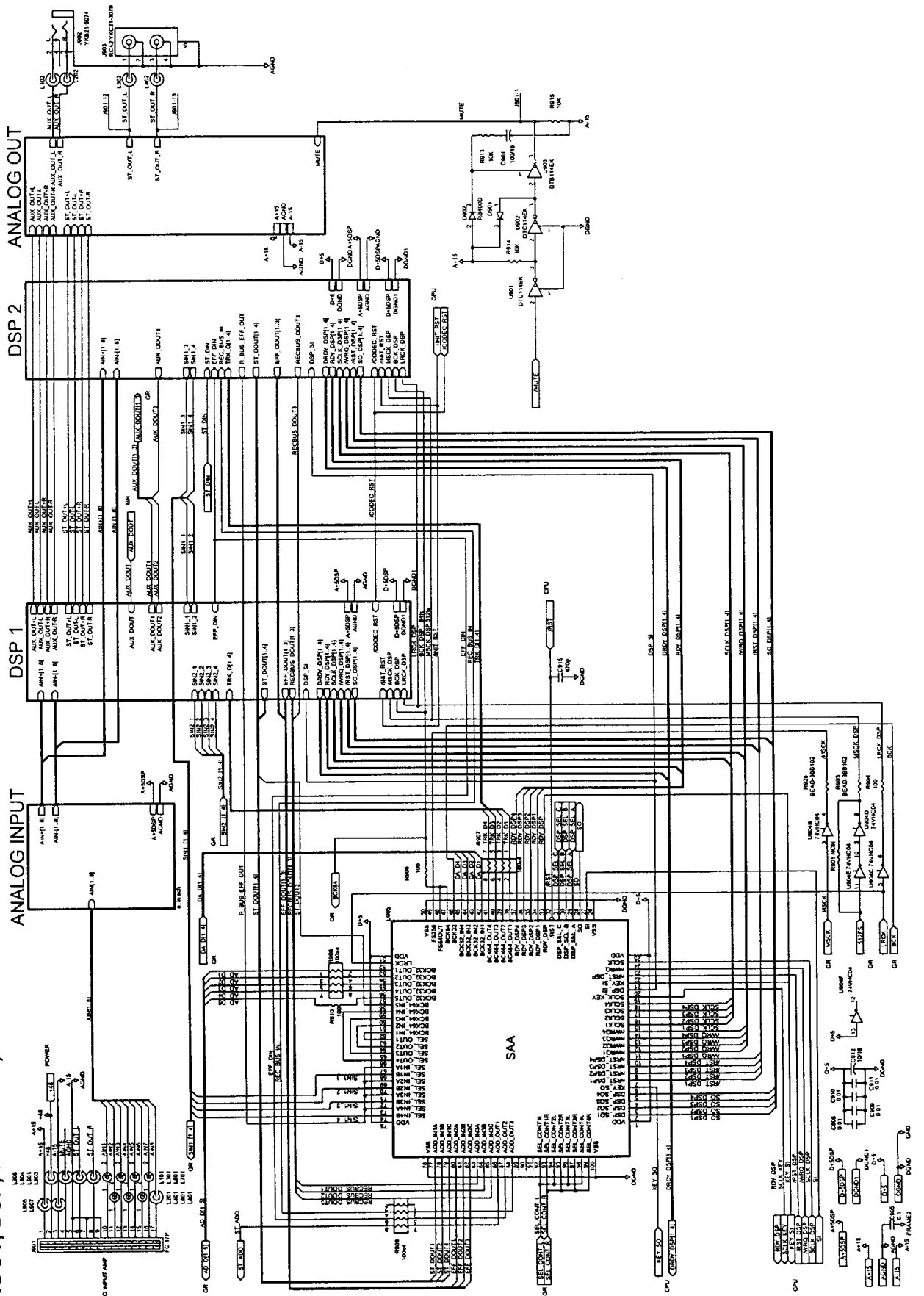

● ANALOG IN, MAIN PCB, VF-16

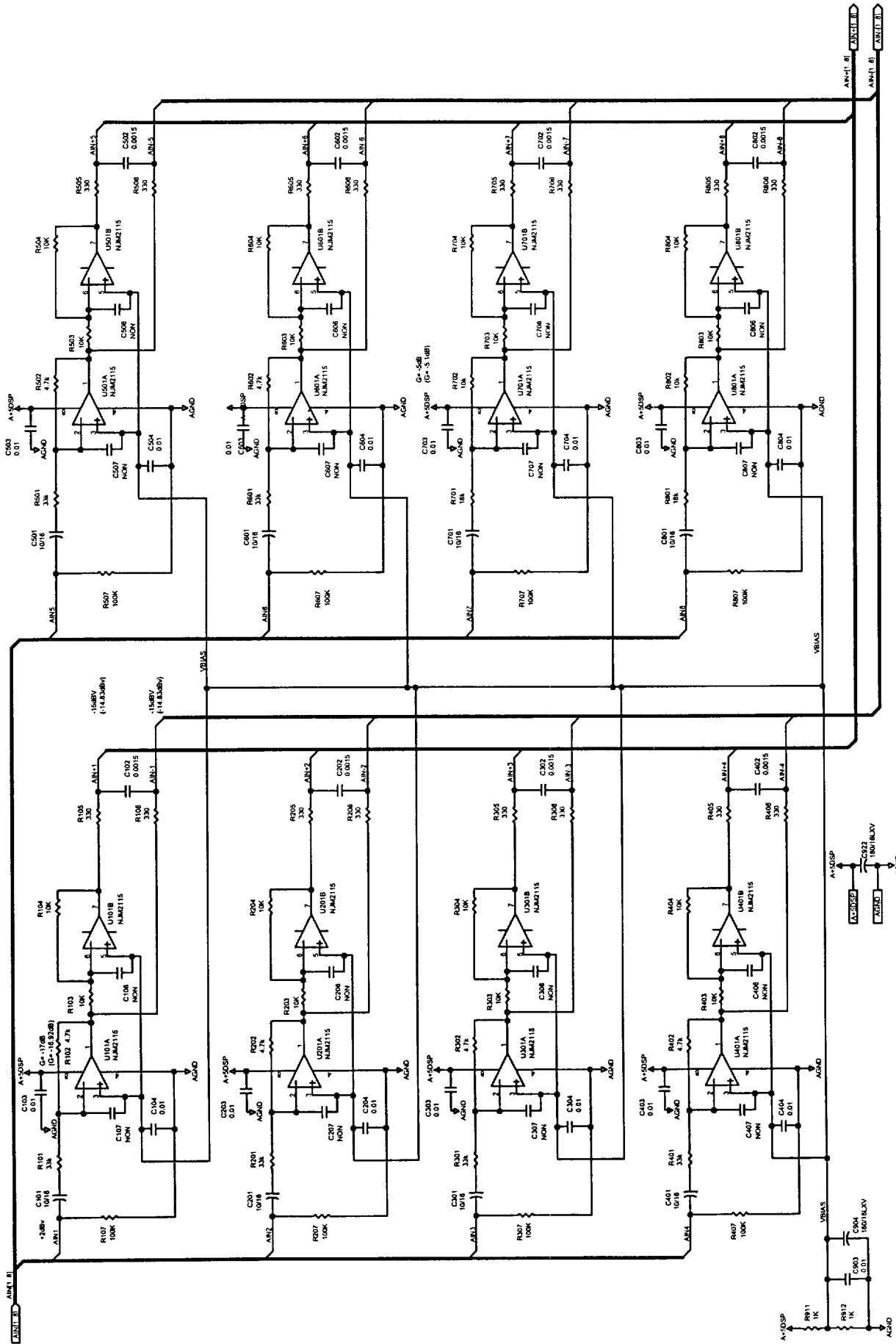

● ANALOG OUT, MAIN PCB, VF-16

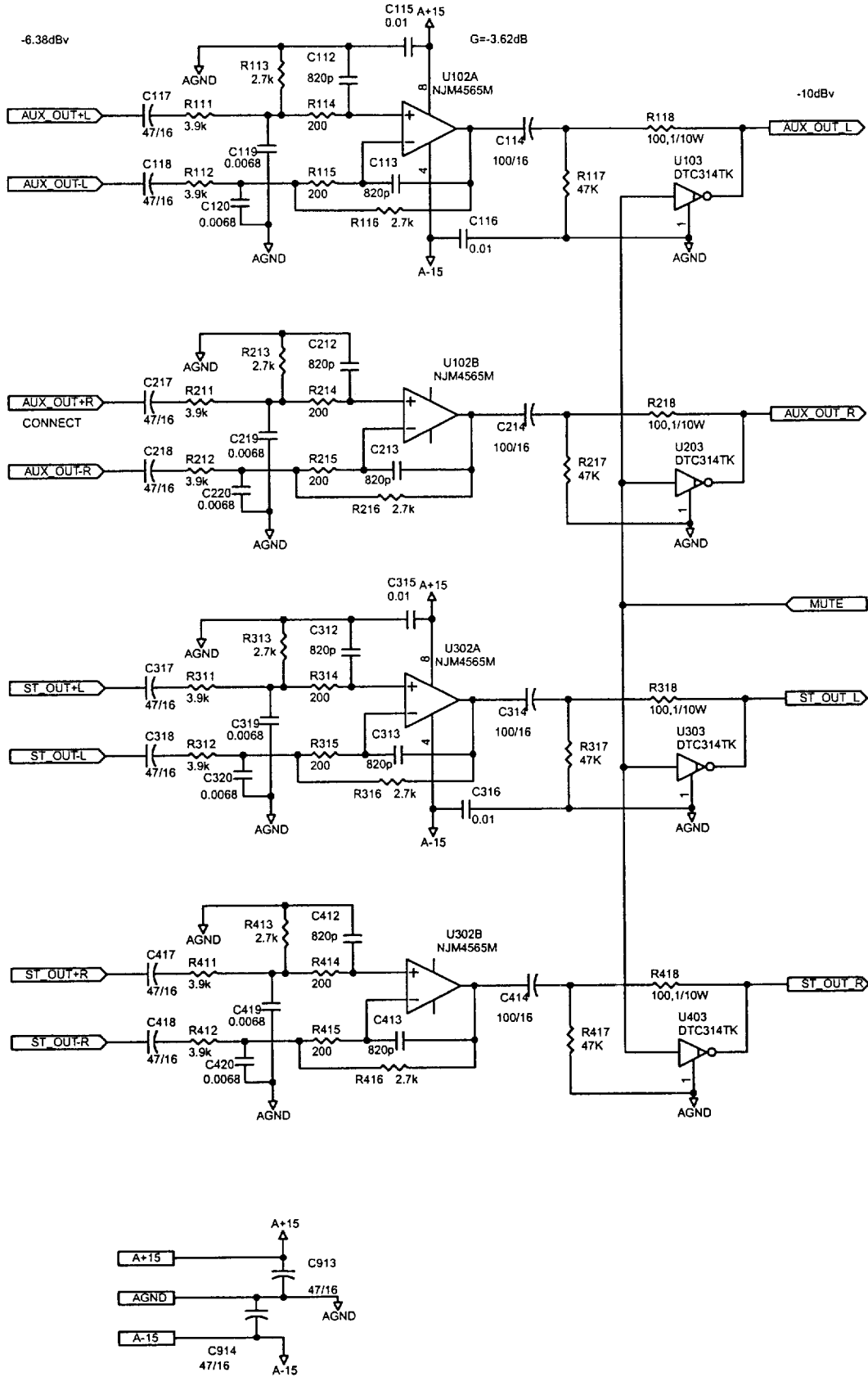

● POWER, MAIN PCB, VF-16

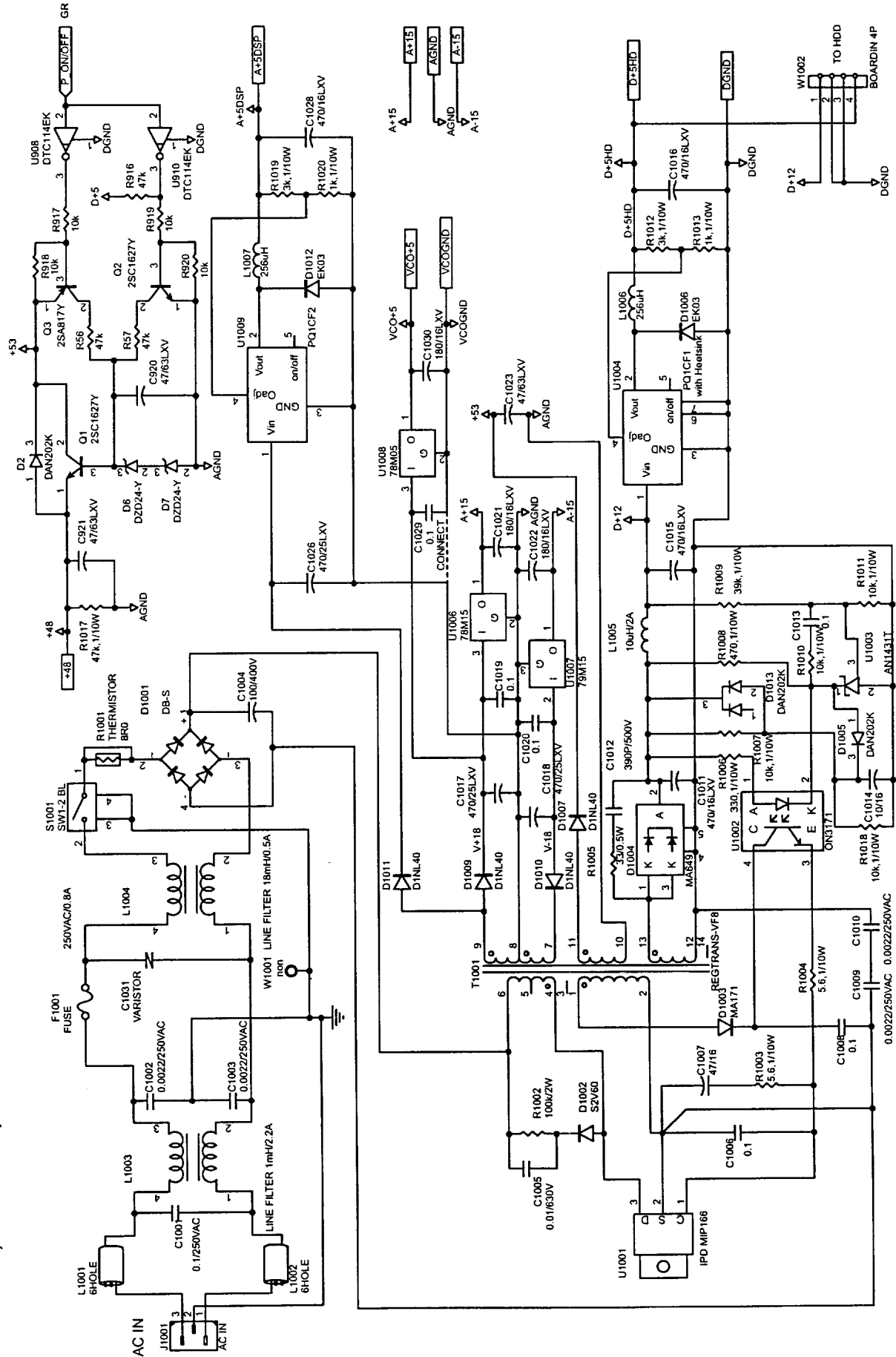

● ROOT, MIC/MONITOR PCB, VF-16

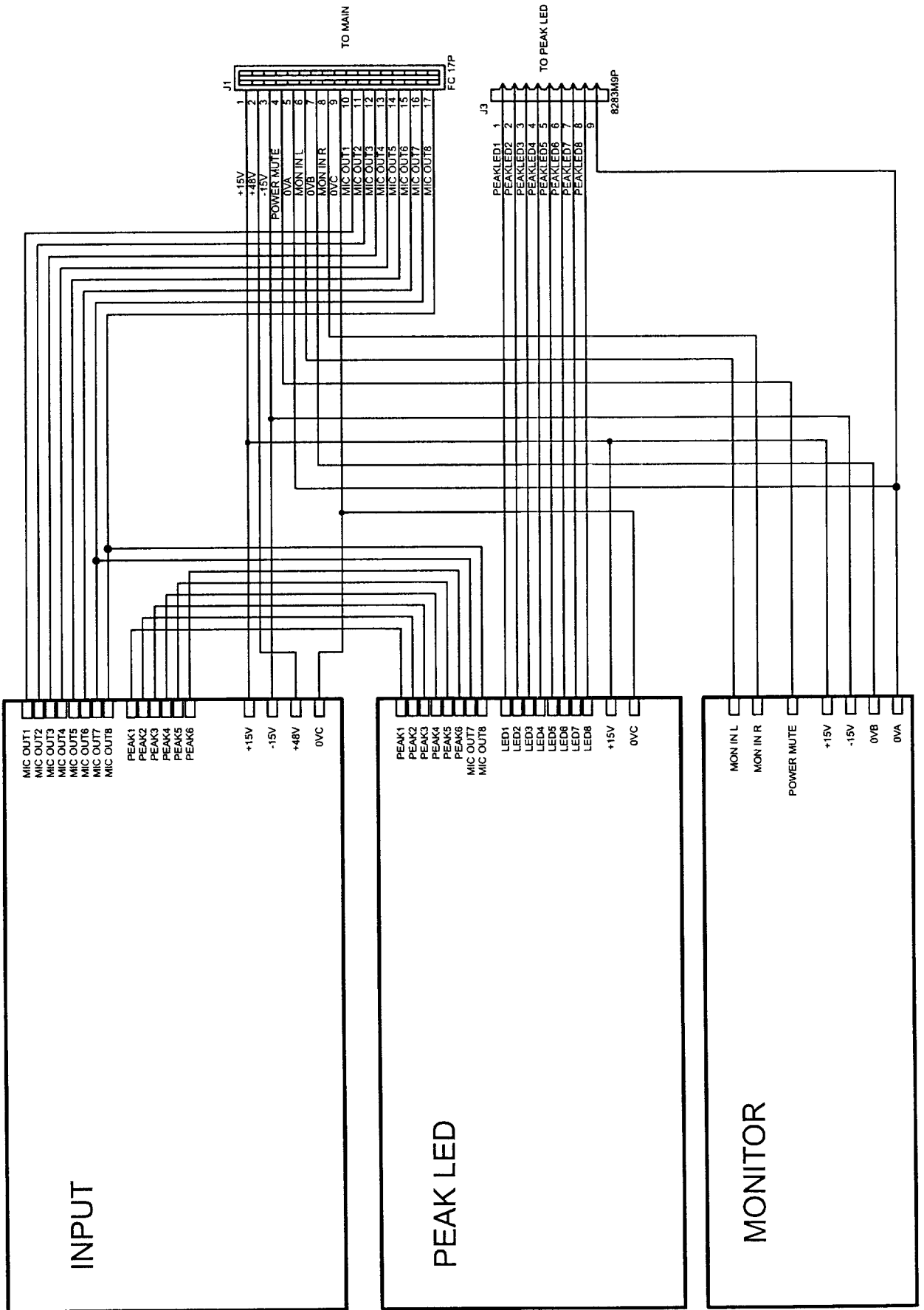

● INPUT, MIC/MONITOR PCB, VF-16

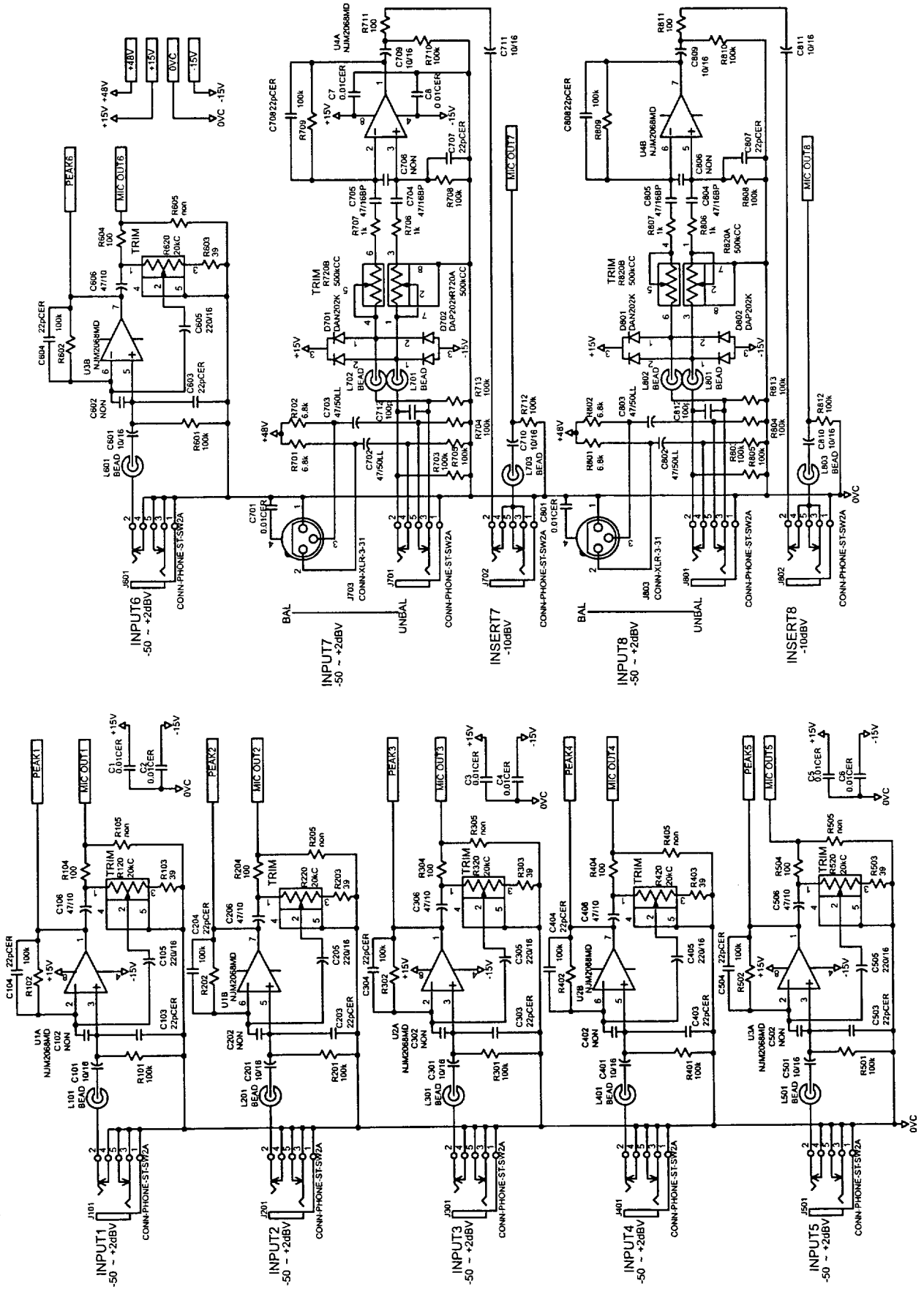

● MONITOR, MIC/MONITOR PCB, VF-16

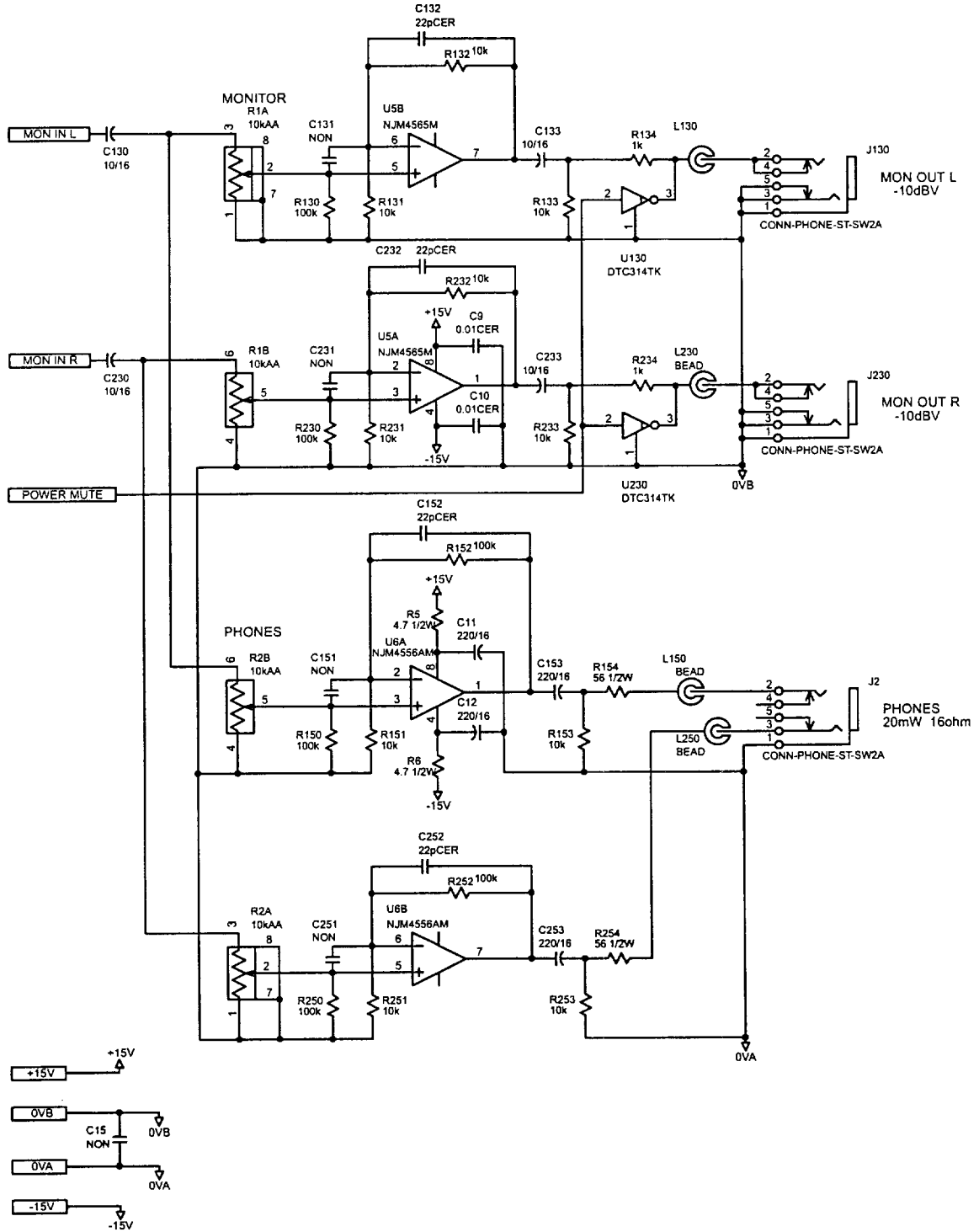

● PEAK LED, MIC/MONITOR PCB, VF-16

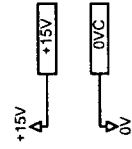
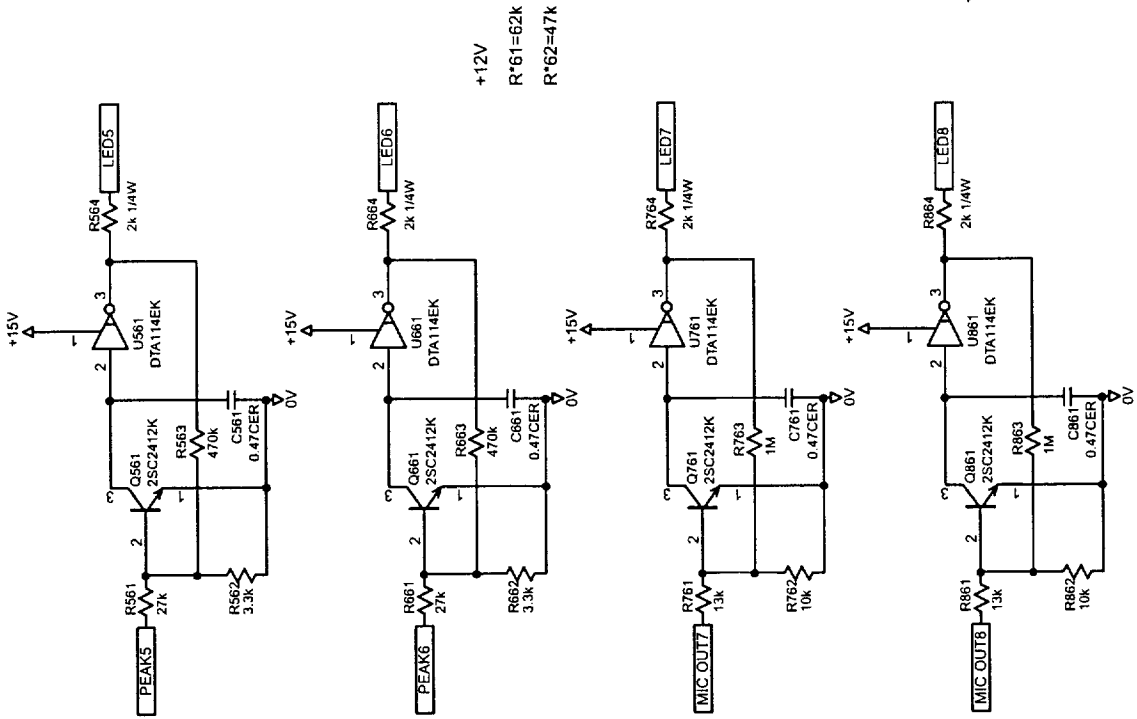
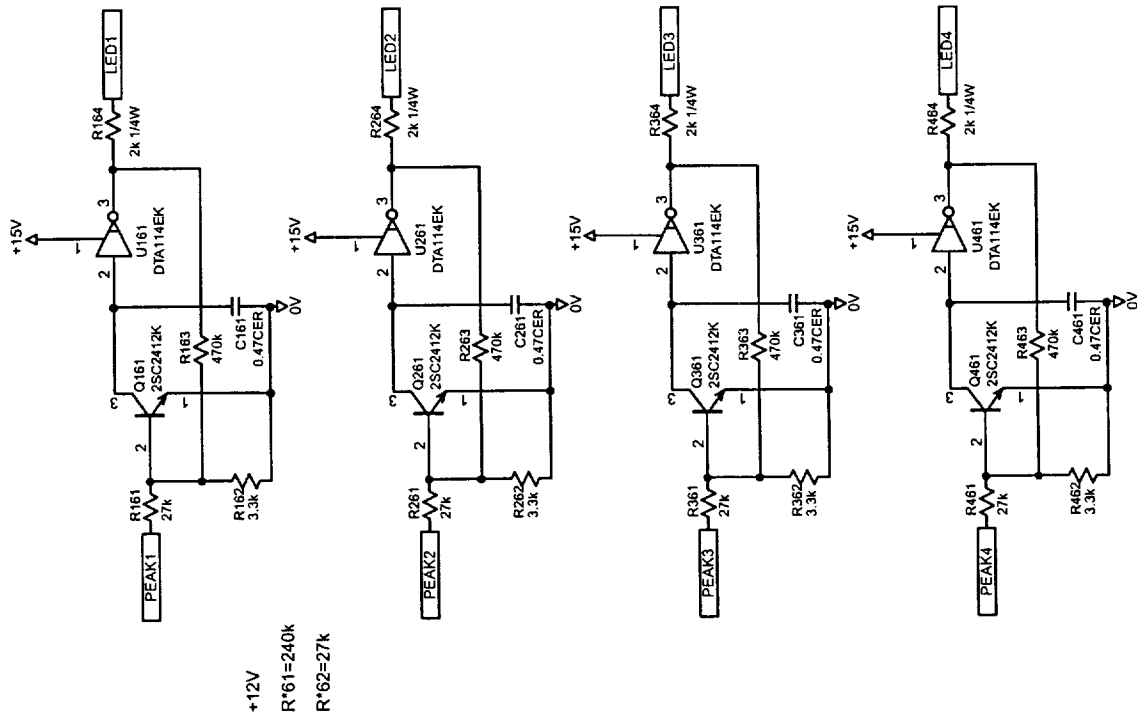

● ROOT, KEY PCB, VF-16

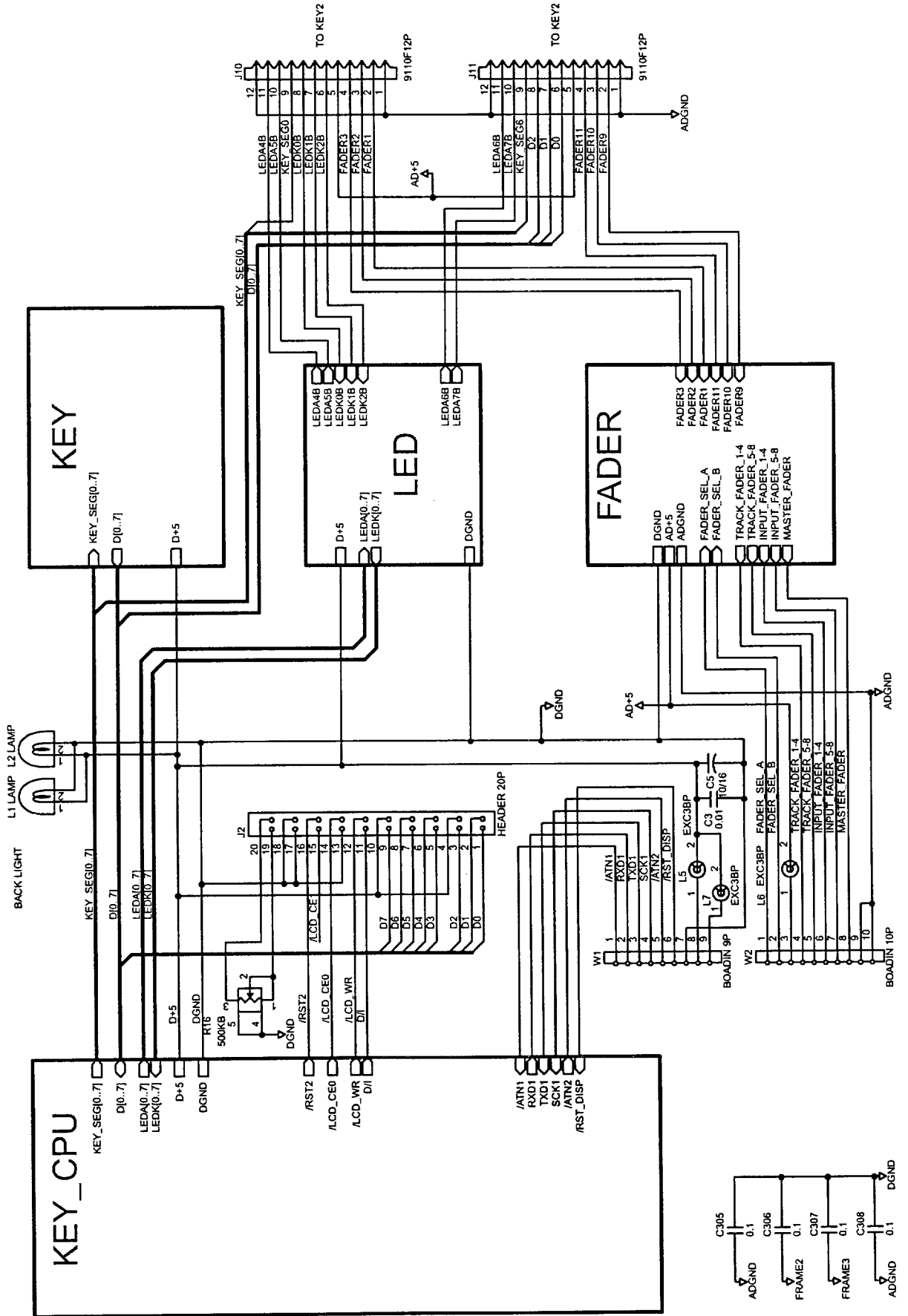

● CPU, KEY PCB, VF-16

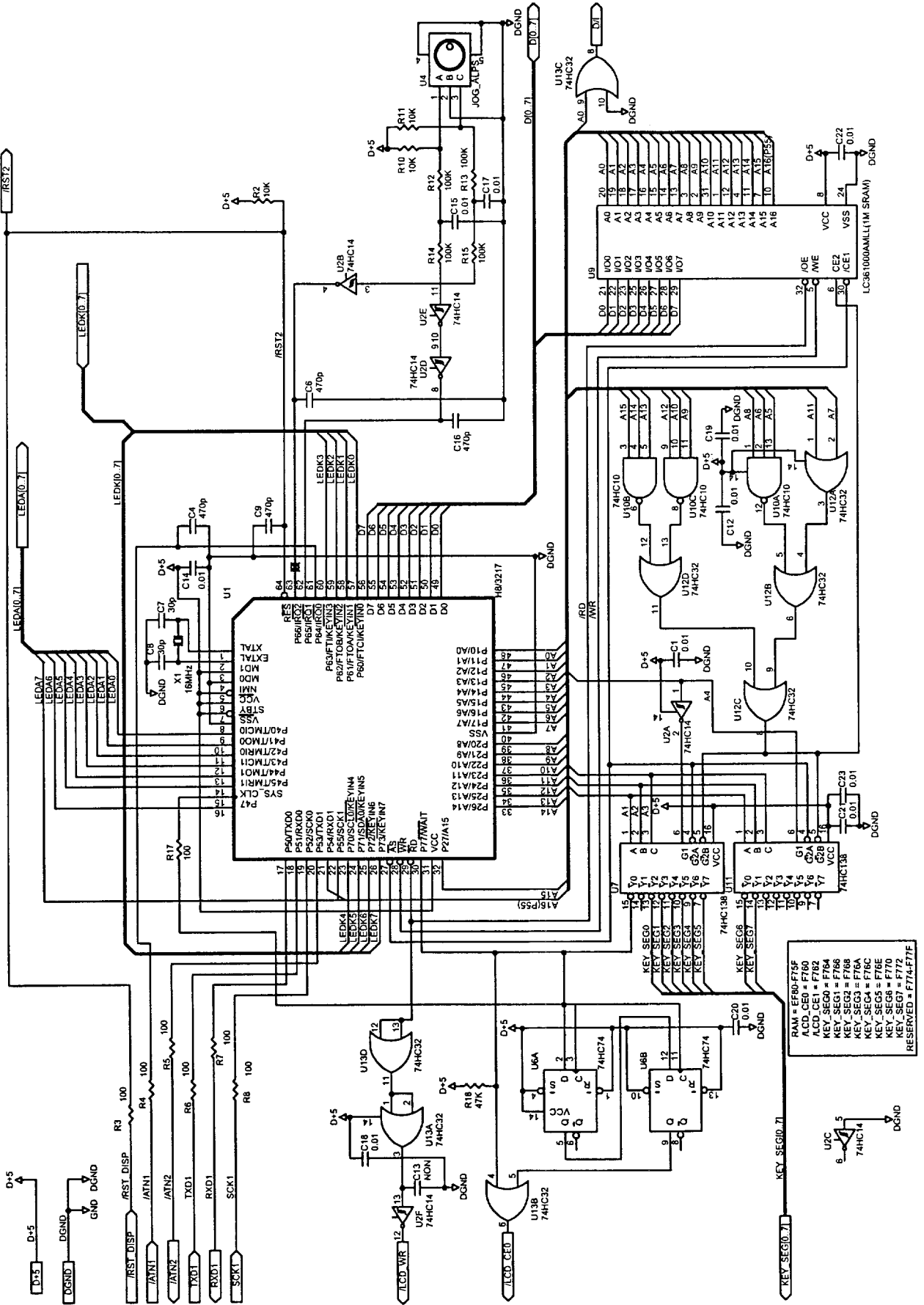

● KEY, KEY PCB, VF-16

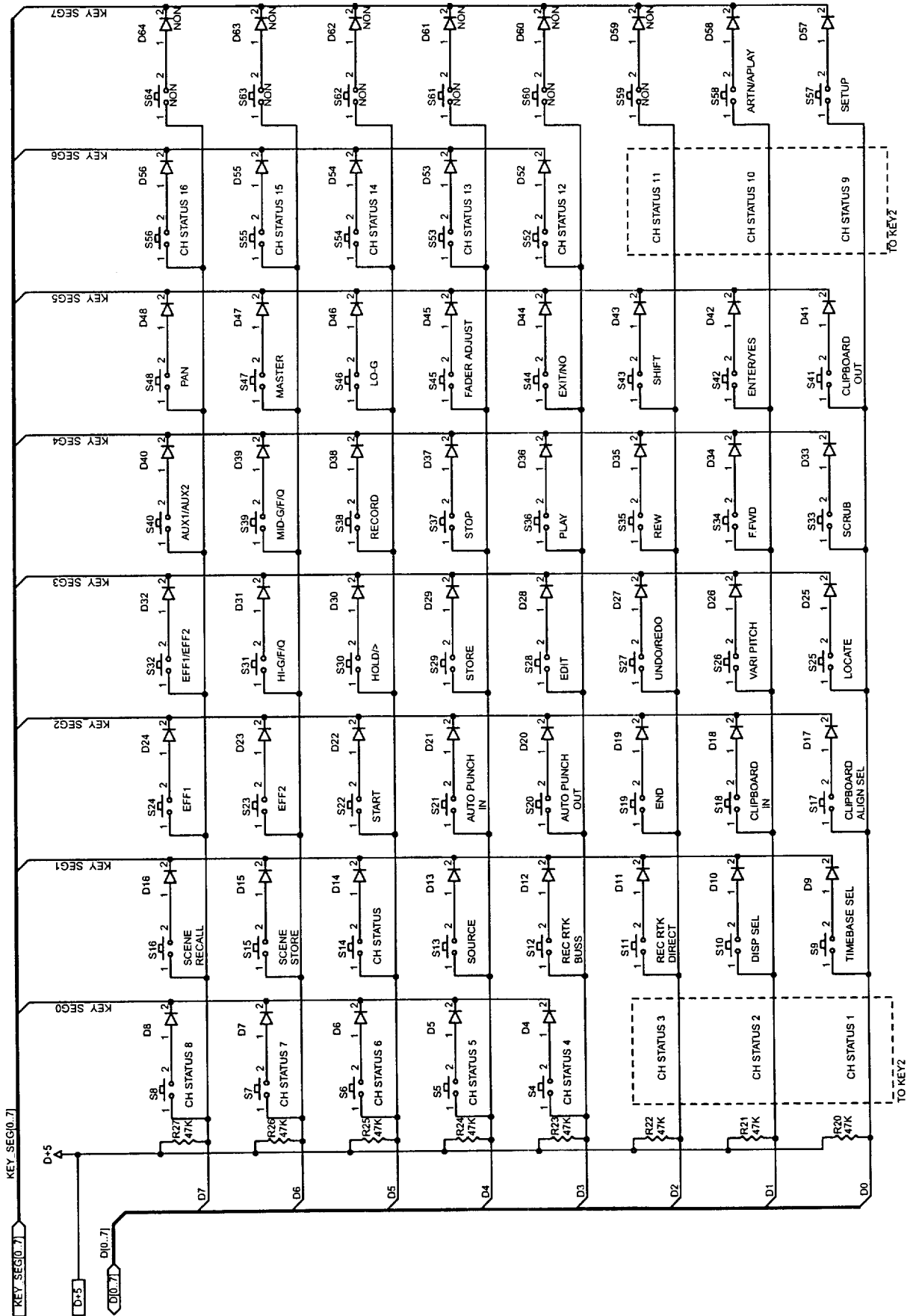

● FADER, KEY PCB, VF-16

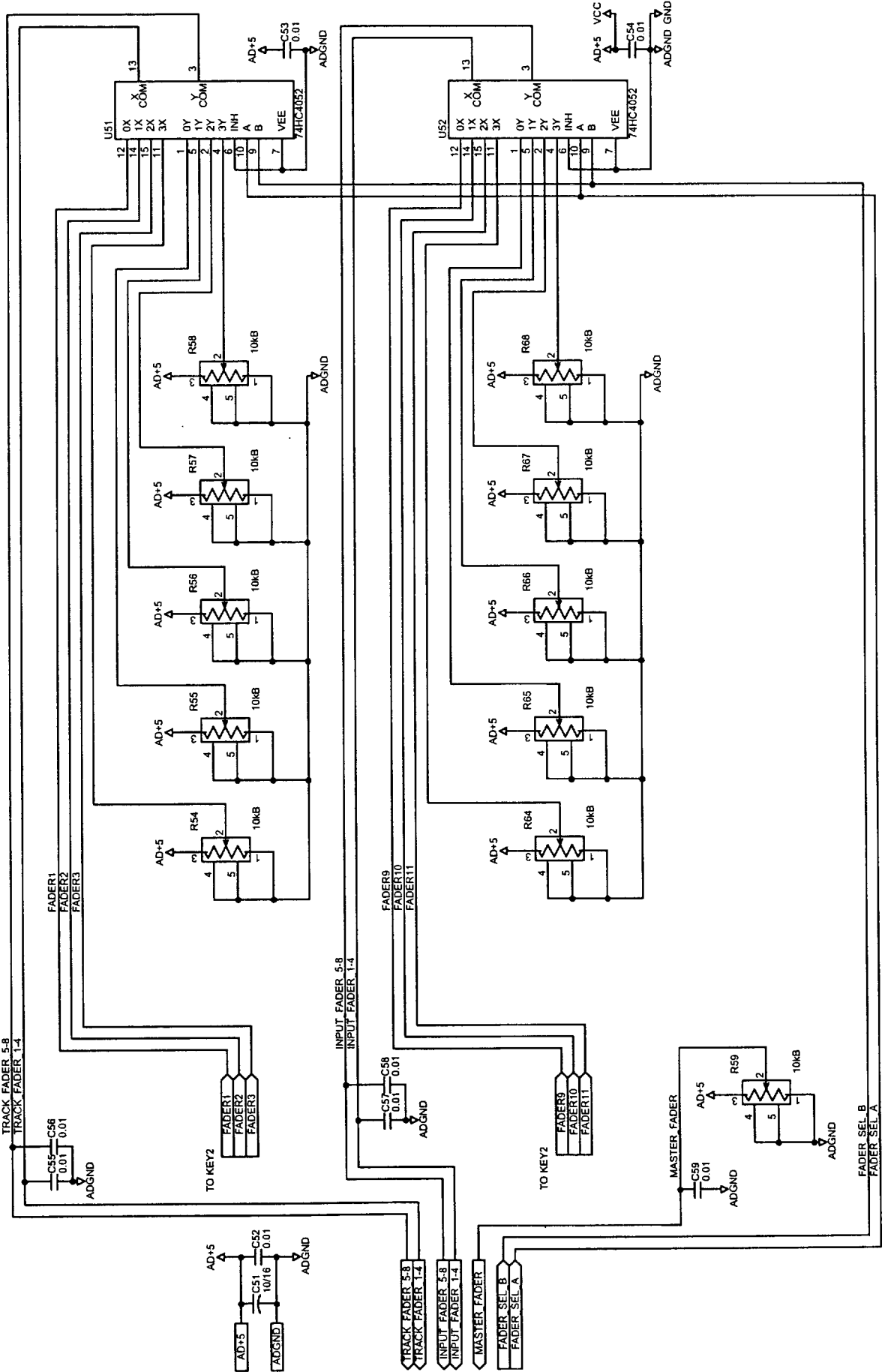

● LCD PCB, VF-16

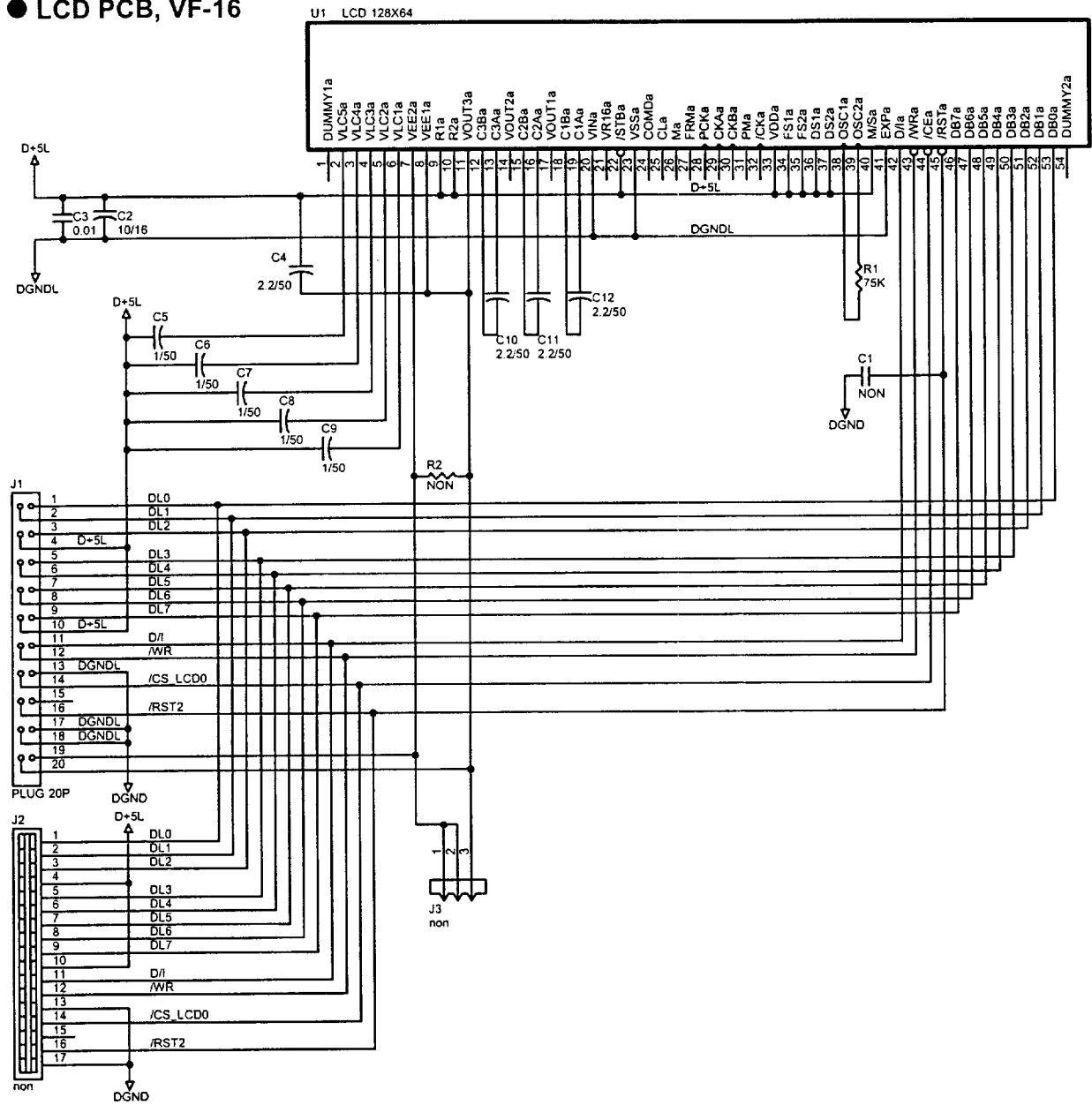

● PEAK LED PCB, VF-16

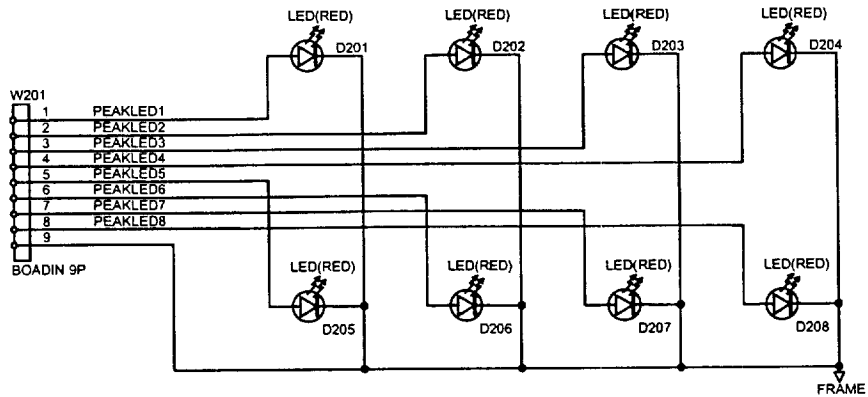

● KEY2 PCB, VF-16

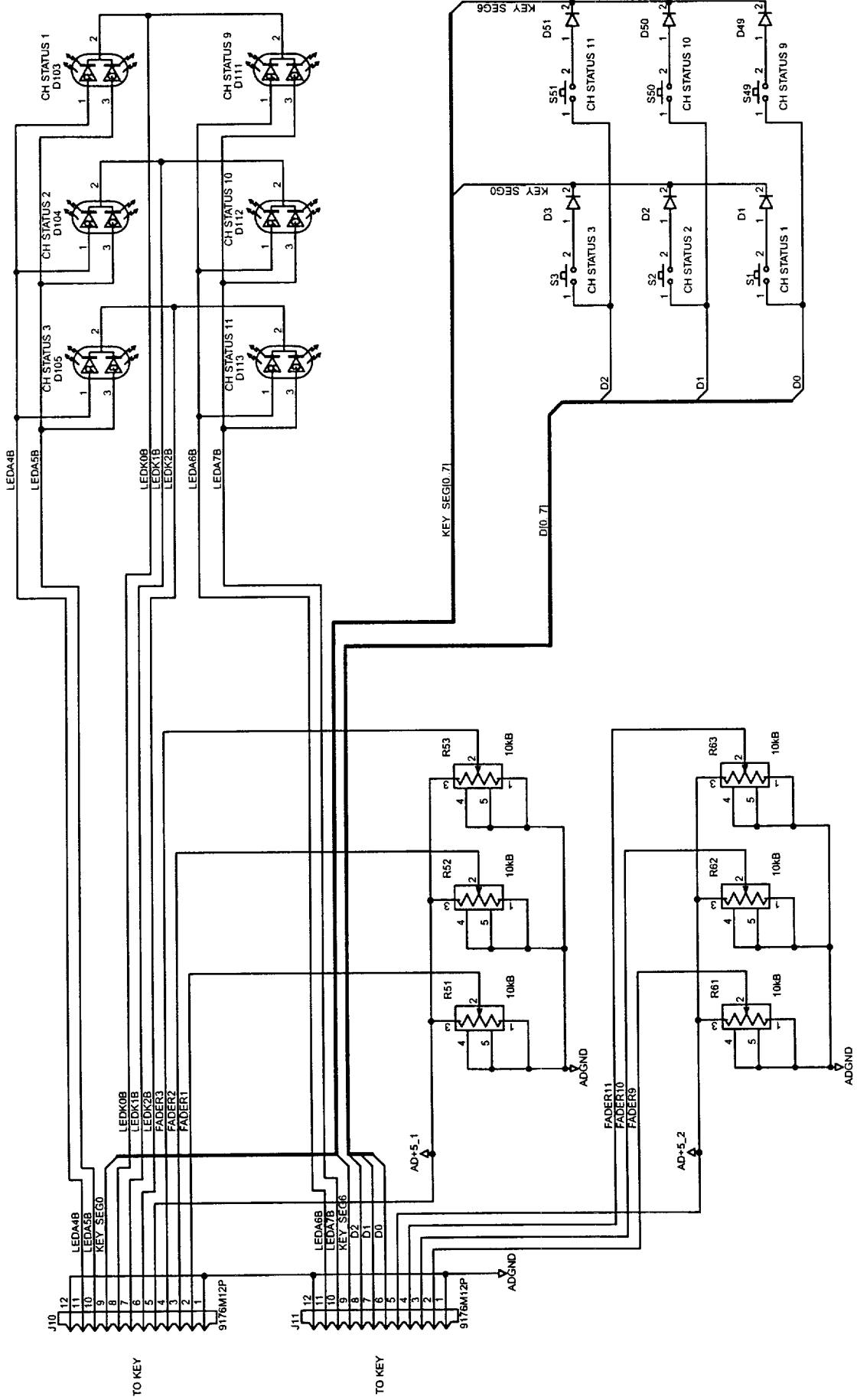

● BLOCK DIAGRAM (INPUT), VF-16

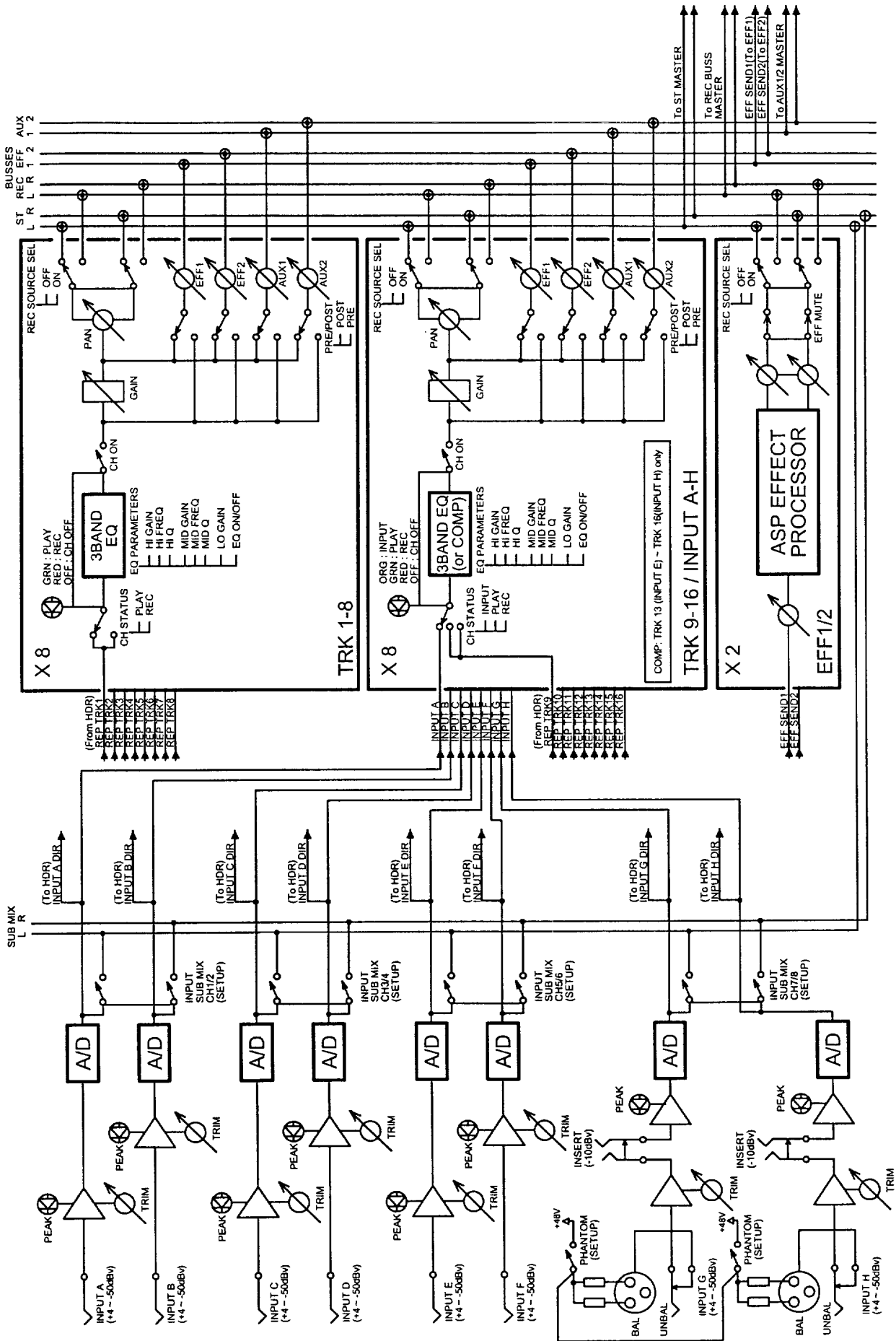

● BLOCK DIAGRAM (OUTPUT), VF-16

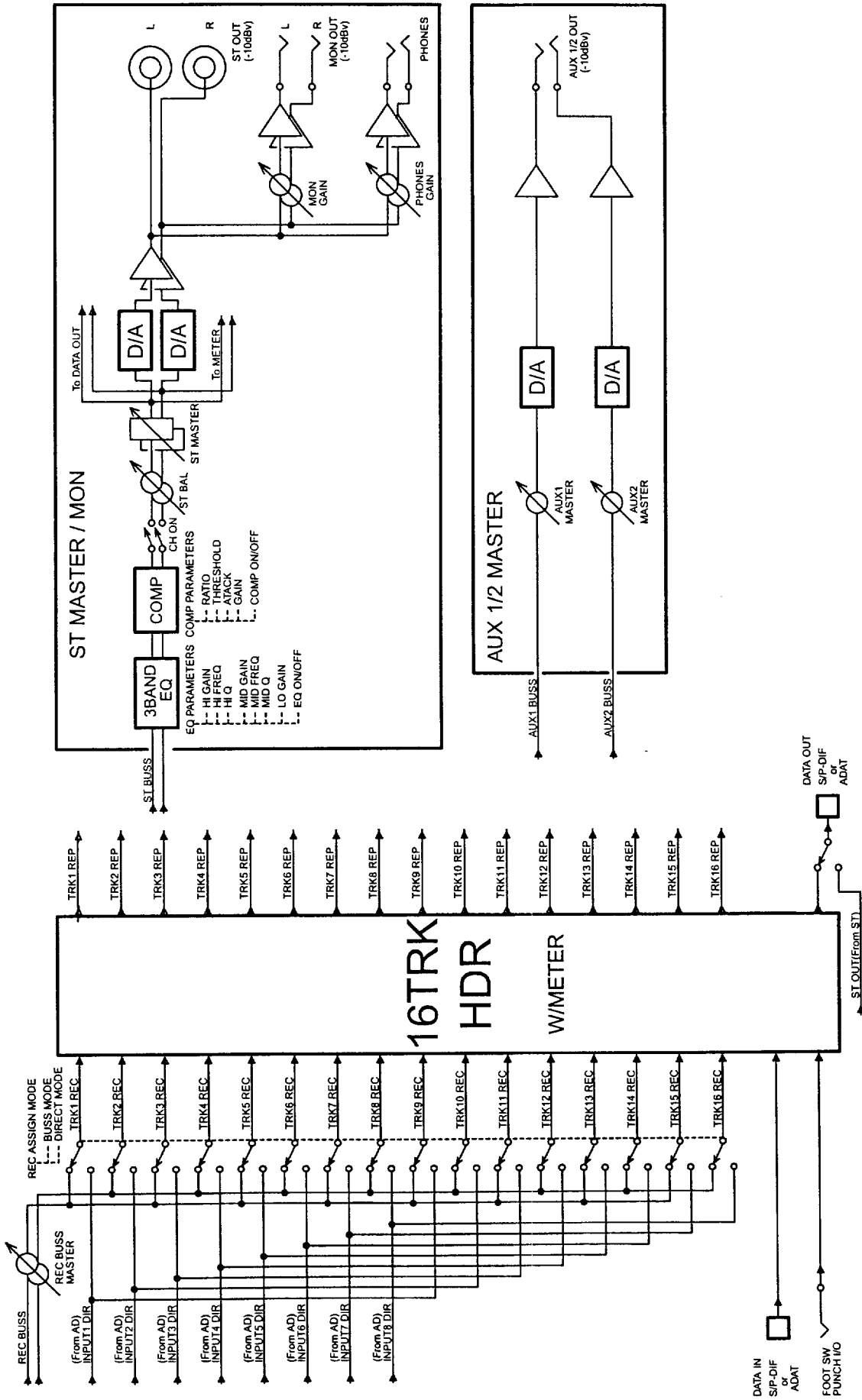

Fostex[®]

FOSTEX CORPORATION 3-2-35 Musashino, Akishima, Tokyo, Japan 196-0021

FOSTEX CORPORATION OF AMERICA 15431 Blackburn Ave., Norwalk, CA 90650, U.S.A.

© PRINTED IN JAPAN JUNE. 2000 8288793000

Fostex®

BULLETIN NO : SB-0565
DATE : November 18, 2000
TO : All Fostex Distributors
FROM : Customer Service Department
SUBJECT : Correction in VF-16 Service Manual

MODEL : VF-16

One of our distributors kindly informed us that the way the LEDs on the VF-16 top panel is lit is different from the one explained in "4-9-1. Key & LED Check" and "4-9-2. LED Check 2" (page 15 - 18) of VF-16 Service Manual. This is true and the description in the service manual is wrong. The correction of LED lighting status is listed below for your information.

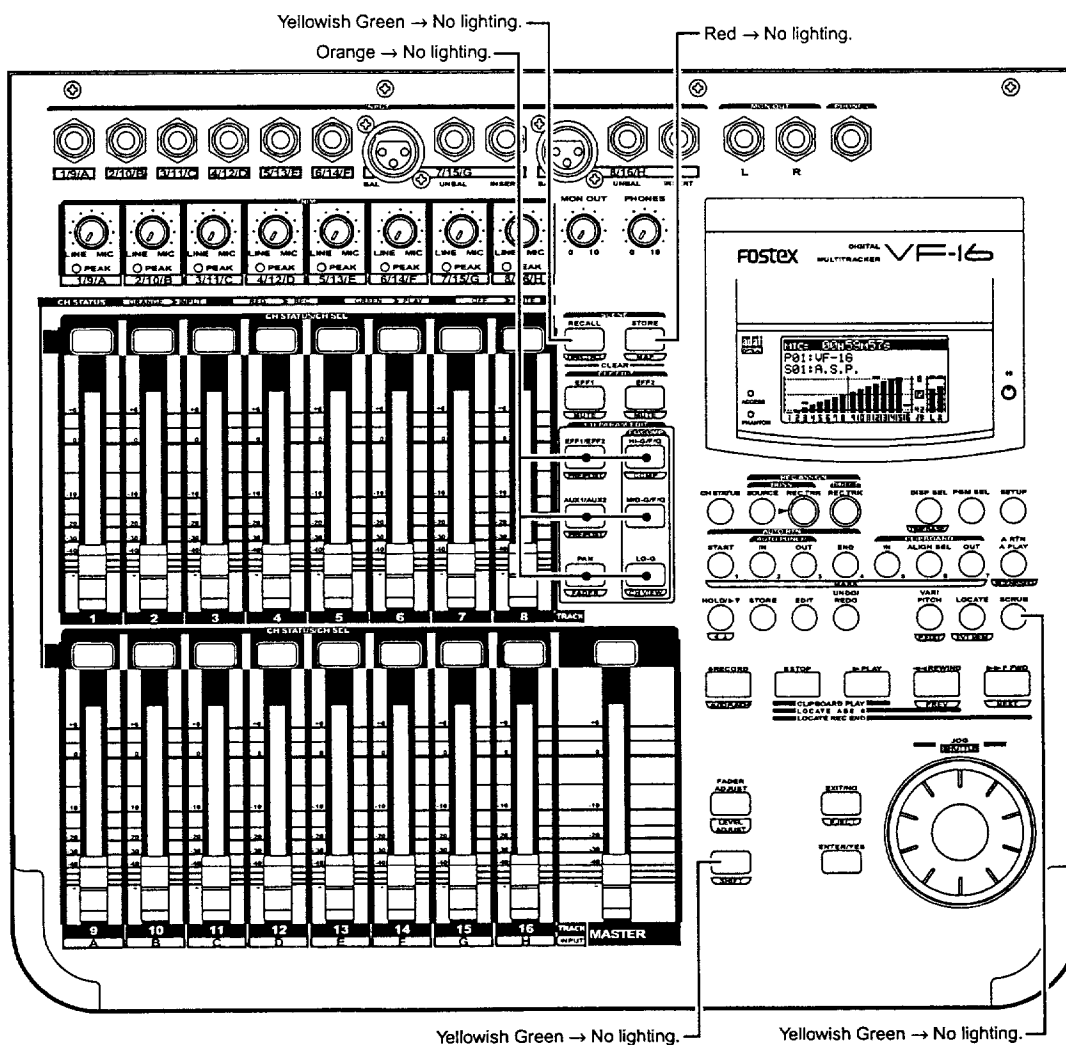

The rectified service manual PDF file (page 15 - 18) is attached.

We are sorry for confusion being caused.

Thank you + best regards,

SB-0565 Correction in VF-16 Service Manual

////////// 1

SERVICE BULLETIN



CAUTION

RISK OF ELECTRIC SHOCK
DO NOT OPEN



CAUTION: TO REDUCE THE RISK OF ELECTRIC SHOCK,

DO NOT REMOVE COVER (OR BACK).

NO USER-SERVICEABLE PARTS INSIDE.

REFER SERVICING TO QUALIFIED SERVICE PERSONNEL.

CAUTION:

TO PREVENT ELECTRIC SHOCK, MATCH WIDE BLADE OF PLUG TO WIDE SLOT, FULLY INSERT.

ATTENTION:

POUR ÉVITER LES CHOCS ÉLECTRIQUES, INTRODUIRE LA LAME LA PLUS LARGE DE LA FICHE DANS LA BORNE CORRESPONDANTE DE LA PRISE ET POUSSER JUSQU' AU FOND.



The lightning flash with arrowhead symbol, within an equilateral triangle, is intended to alert the user to the presence of uninsulated "dangerous voltage" within the product's enclosure that may be of sufficient magnitude to constitute a risk of electric shock to persons.



The exclamation point within an equilateral triangle is intended to alert the user to the presence of important operating and maintenance (servicing) instructions in the literature accompanying the appliance.

"WARNING"

"TO REDUCE THE RISK OF FIRE OR ELECTRIC SHOCK, DO NOT EXPOSE THIS APPLIANCE TO RAIN OR MOISTURE."

SAFETY INSTRUCTIONS

1. Read instructions - All the safety and operating instructions should be read before the appliance is operated.
2. Retain instructions - The safety and operating instructions should be retained for future reference.
3. Heed warnings - All warnings on the appliance and in the operating instructions should be adhered to.
4. Follow instructions - All operating and use instructions should be followed.
5. Water and Moisture - The appliance should not be used near water - for example, near a bathtub, washbowl, kitchen sink, laundry tub, in a wet basement, or near a swimming pool, and the like.
6. Carts and Stands - The appliance should be used only with a cart or stand that is recommended by the manufacturer.



An appliance and cart combination should be moved with care. Quick stops, excessive force, and uneven surfaces may cause the appliance and cart combination to overturn.

7. Wall or Ceiling Mounting - The appliance should be mounted to a wall or ceiling only as recommended by the manufacturer.
8. Ventilation - The appliance should be situated so that its location or position does not interfere with its proper ventilation. For example, the appliance should not be situated on a bed, sofa, rug, or similar surface that may block the ventilation openings; or, placed in a built-in installation, such as a bookcase or cabinet that may impede the flow of air through the ventilation openings.

9. Heat - The appliance should be situated away from heat sources such as radiators, heat registers, stoves, or other appliances (including amplifiers) that produce heat.
10. Power Sources - The appliance should be connected to a power supply only of the type described in the operating instructions or as marked on the appliance.
11. Grounding or Polarization - The precautions that should be taken so that the grounding or polarization means of an appliance is not defeated.
12. Power Cord Protection - Power supply cords should be routed so that they are not likely to be walked on or pinched by items placed upon or against them, paying particular attention to cords at plugs, convenience receptacles, and the point where they exit from the appliance.
13. Cleaning - The appliance should be cleaned only as recommended by the manufacturer.
14. Nonuse Periods - The power cord of the appliance should be unplugged from the outlet when left unused for a long period of time.
15. Object and Liquid Entry - Care should be taken so that objects do not fall and liquids are not spilled into the enclosure through openings.
16. Damage requiring Service - The appliance should be serviced by qualified service personnel when:
 - A. The power supply cord or the plug has been damaged; or
 - B. Objects have fallen, or liquid has been spilled into the appliance; or
 - C. The appliance has been exposed to rain; or
 - D. The appliance does not appear to operate normally or exhibits a marked change in performance; or
 - E. The appliance has been dropped, or the enclosure damaged.
17. Servicing - The user should not attempt to service the appliance beyond that described in the operating instructions. All other servicing should be referred to qualified service personnel.

TABLE OF CONTENTS

1. SPECIFICATIONS	
2. CONTROLS, INDICATORS & CONNECTORS	
3. SOFTWARE UPDATE	
4. SERVICE MODE	
5. ERROR CODE LIST	19
6. EXPLODED VIEW, PCB ASSEMBLY & PARTS LIST	20
7. CIRCUIT & BLOCK DIAGRAMS	34

NOTES

* Service mode, exploded view, PCB assembly, parts list and circuit diagrams are given in this manual to assist the service technician in maintaining the Model VF-16.

* Following accessories are supplied with VF-16 as the standard accessories.

VF-16 English owner's manual	: 8288451100
VF-16 Japanese owner's manual	: 8288452100

* Following is the packing material for the Model VF-16.

Carton, inner, VF-16	: 8228735000
Carton, outer, VF-16	: 8228913000
Packing, side, L, VF-16	: 8228463000
Packing, side, R, VF-16	: 8228464000

CAUTION

△ Parts marked with this sign are safety critical components. They must always be replaced with identical components. Refer to the Fostex Parts List and ensure exact replacement.

1. SPECIFICATIONS

DEFINITION

Specification Unit

0 dBV = 1 Vrms

Standard Condition

Measure the specifications referring to the chart below.

* Fader position & PAN assignment in each setting.

	Odd CH.		Even CH.		Master		AUX		Eff Send		PRE/POST	Effect
	Level	PAN	Level	PAN	Level	Balance	1	2	1	2		
SETTING 1	80	L	80	R	80	C	80	80	0	0	POST	-
SETTING 2	80	L	80	L	80	C	80	80	0	0	POST	-

SPECIFICATIONS

Standard Input

Input A ~ F

Connector

PHONE, unbalanced

Input level

-50 ~ +2 dBV

Impedance

50 k or more

Input G, H

Connector

PHONE, unbalanced / XLR, balanced (Pin-2: HOT)

Input level

-50 ~ +2 dBV

Impedance

50 k or more (PHONE), 1 k or more (XLR)

Insert 1, 2

Connector

Stereo PHONE (ring)

Input level

-10 dBV

Impedance

10 k or more

DATA IN

Connector

Square shape optical

Format

IEC consumer Optical Standard EN60958 (S/P DIF)

Alesis Proprietary Mutichannel Optical Digital Interface

PEAK LED On Level (INPUT A ~ H)

Full scale level - 2 dB ± 1 dB

Standard Output

STEREO OUT

Connector

RCA pin, unbalanced

Output level

-10 dBV

Impedance

10 k or more

MONITOR OUT

Connector

PHONE, unbalanced

Output level

-10 dBV

Impedance

10 k or more

PHONES OUT

Connector

Stereo PHONE, unbalanced

Output level

20 mW or more (16 load)

Impedance

16 ~ 50

AUX SEND 1

Connector

Stereo PHONE (tip), unbalanced

Output level

-10 dBV

Impedance

10 k or more

AUX SEND 2

Connector

Stereo PHONE (ring), unbalanced

Output level

-10 dBV

Impedance

10 k or more

INSERT 1, 2

Connector

Stereo PHONE (tip), unbalanced

Output level

-10 dBV

Impedance

10 k or more

Phantom power	
Connector	XLR
Output level	48 ± 4 V (ON/OFF by SETUP mode)
Impedance	10 k or more
DATA OUT	
Connector	Square shape optical
Format	IEC consumer Optical Standard EN60958 (S/P DIF) Alesis Proprietary Mutichannel Optical Digital Interface
Control System Input & Output	
SCSI DATA	
Connector	Half pitch 50-pin female
Protocol	SCSI-2, unbalanced transfer method
Transfer type	Asynchronous
Number of units connected	
MIDI IN/OUT	
Connector	DIN 5-pin
Format	MIDI standard
PUNCH IN/OUT	
Connector	PHONE (TTL level)
Output Level (SETTING 1)	
INPUT (+2 dBV, 1 kHz)→ STEREO OUT	-10 dBV ± 2 dB
INPUT (-50 dBV, 1 kHz)→ STEREO OUT	-10 dBV ± 2 dB
INPUT (+2 dBV, 1 kHz)→ AUX SEND 1, 2	-10 dBV ± 2 dB
Frequency Response (SETTING 1)	
INPUT (+2 dBV, 20 ~ 20 kHz)→ MONITOR OUT	+1, -2 dB
INPUT (-50 dBV, 20 ~ 20 kHz)→ MONITOR OUT	+1, -3 dB
INPUT (+2 dBV, 20 ~ 20 kHz)→ AUX SEND 1, 2	+1, -2 dB
EQ Characteristics (SETTING 1)	
HI (Frequency: 500 ~ 20 kHz, Q: 0.1 ~ 20)	±18 dB ± 3 dB
MID (Frequency: 500 ~ 20 kHz, Q: 0.1 ~ 20)	±18 dB ± 3 dB
LO (Frequency: 400 Hz)	±18 dB ± 3 dB
S/N (SETTING 1, : SETING 2)	
INPUT (+2 dBV)→ MONITOR OUT	88 dB or more (with 20kHz LPF + A-curve filter*)
INPUT (-50 dBV)→ MONITOR OUT	80 dB or more (with 20kHz LPF + A-curve filter*)
INPUT A ~ H (+2 dBV)→ MONITOR OUT	79 dB or more (with 20kHz LPF + A-curve filter*)
INPUT A ~ H (-50 dBV)→ MONITOR OUT	74 dB or more (with 20kHz LPF + A-curve filter*)
PHONES OUTPUT residual noise	-85 dBV or less (with 20kHz LPF + A-curve filter*)
T.H.D. (SETTING 1)	
INPUT (+2 dBV)→ MONITOR OUT (-10 dBV)	0.05 % or less (with 20kHz LPF + A-curve filter*)
INPUT (-40 dBV)→ MONITOR OUT (0 dBV)	0.05 % or less (with 20kHz LPF + A-curve filter*)
INPUT (+2 dBV)→ PHONES OUT (20 mW/16	0.05 % or less (with 20kHz LPF + A-curve filter*)
Dynamic Range (SETTING 1)	
INPUT (+2 dBV)→ MONITOR OUT (-10 dBV)	88 dB or more (with 20kHz LPF + A-curve filter*)
Crosstalk (SETTING 1)	60 dB or more (Frequency: 1 kHz)
Click Noise (SETTING 1)	
Power ON/OFF	-20 dBVp-p or less
Other switching	-30 dBVp-p or less
GENERAL	
Dimensions	380 (W) x 98 (H) x 335 (D) mm
Weight	Approx. 4.0 kg
Power Requirement	100V AC, 120V AC, 230V AC
Power Consumption	15 W

* A-curve filter: with IEC 651A characteristic

Specifications are subject to change without notice for product improvement.

2. CONTROLS, INDICATORS & CONNECTORS

<Top Panel Section >

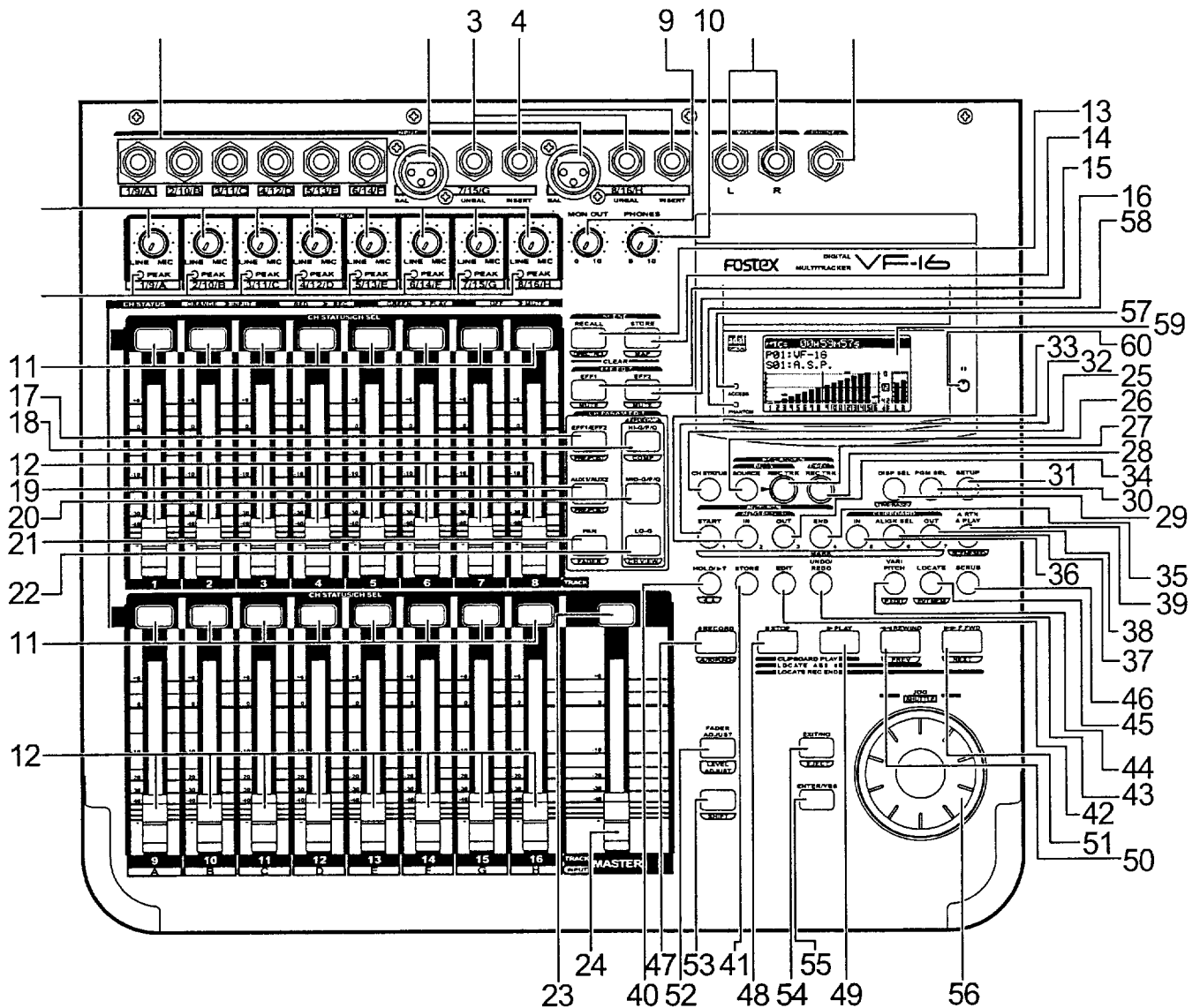

- | | |
|--|---|
| 1. [INPUT] (unbalanced) terminal: A ~ F | 18. [CH PARAM EDIT - EQ/COMP - HI-G/F/Q / <u>COMP</u>] key |
| 2. [INPUT BAL] (balanced) terminal: G, H | 19. [CH PARAM EDIT - AUX1/AUX2 / <u>PRE/POST</u>] key |
| 3. [INPUT UNBAL] (unbalanced) terminal: G, H | 20. [CH PARAM EDIT - EQ/COMP - MID-G/F/Q] key |
| 4. [INSERT] terminal: G, H | 21. [CH PARAM EDIT - PAN / <u>ADER</u>] key |
| 5. [MON OUT] terminal: L, R | 22. [CH PARAM EDIT - EQ/COMP - LO-G / <u>CH VIEW</u>] key |
| 6. [PHONES] terminal | 23. [MASTER CH STATUS/CH SEL] key |
| 7. [PEAK] LED: 1 ~ 8 | 24. [MASTER] fader |
| 8. [TRIM] knob: 1 ~ 8 | 25. [INPUT SEL] key |
| 9. [MON OUT] knob | 26. [REC ASSIGN - BUSS - SOURCE] key |
| 10. [PHONES] knob | 27. [REC ASSIGN - BUSS - REC TRK] key |
| 11. [CH STATUS/CH SEL] key: 1 ~ 16 channel | 28. [REC ASSIGN - DIRECT - REC TRK] key |
| 12. Channel fader: 1 ~ 16 channel | 29. [DISP SEL / <u>TIMEBASE</u>] key |
| 13. [SCENE - RECALL / <u>DIRECT RCL</u>] key | 30. [PGM SEL] key |
| 14. [SCENE - STORE / <u>MAP</u>] key | 31. [SETUP] key |
| 15. [EFF EDIT - EFF1 / <u>MUTE</u>] key | 32. [AUTO RTN - START / <u>MARK1</u>] key |
| 16. [EFF EDIT - EFF2 / <u>MUTE</u>] key | 33. [AUTO PUNCH - IN / <u>MARK2</u>] key |
| 17. [CH PARAM EDIT - EFF1/EFF2 / <u>PRE/POST</u>] key | 34. [AUTO PUNCH - OUT / <u>MARK3</u>] key |

- | | |
|---|---|
| 35. [AUTO RTN - END / <u>MARK4</u>] key | 48. [STOP] key |
| 36. [CLIPBOARD - IN / <u>MARK5</u>] key | 49. [PLAY] key |
| 37. [CLIPBOARD - ALIGN SEL / <u>MARK6</u>] key | 50. [REWIND / PREV] key |
| 38. [CLIPBOARD - OUT / <u>MARK7</u>] key | 51. [F FWD / <u>NEXT</u>] key |
| 39. [A RTN/A PLAY / <u>SCENE SEQ</u>] key | 52. [FADER ADJUST / <u>LEVEL ADJUST</u>] key |
| 40. [HOLD/▶▼] key / ◀▲ | 53. [SHIFT] key |
| 41. [STORE] key | 54. [EXIT/NO / <u>EJECT</u>] key |
| 42. [EDIT] key | 55. [ENTER/YES] key |
| 43. [UNDO/REDO] key | 56. [JOG / <u>SHUTTLE</u>] key |
| 44. [VARI PITCH / <u>EDIT</u>] key | 57. [ACCESS] LED |
| 45. [LOCATE / <u>LOC MEM</u>] key | 58. [PHANTOM] LED |
| 46. [SCRUB] key | 59. LCD |
| 47. [RECORD / <u>UTO PUNCH</u>] key | 60. Contrast adjusting knob |

< Rear Panel Section >

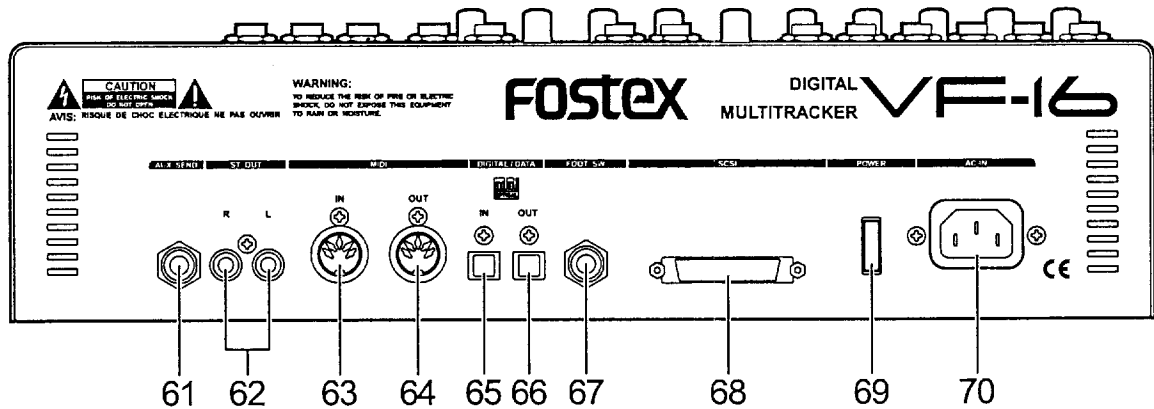

- | | |
|--------------------------------|---------------------------------|
| 61. [AUX SEND - 1/2] terminal | 66. [DIGITAL/DATA OUT] terminal |
| 62. [ST OUT - L/R] terminal | 67. [FOOT SW] terminal |
| 63. [MIDI IN] terminal | 68. [SCSI] terminal |
| 64. [MIDI OUT] terminal | 69. [POWER] |
| 65. [DIGITAL/DATA IN] terminal | 70. [AC IN] terminal |

3. SOFTWARE UPDATE

Since the 8Mbit flash ROM is mounted on the MAIN PCB assy, the VF-16 software can be updated through the SCSI port. Please refer to the following explanation for correct software updating procedures.

3-1. Required Tools

The following tools/equipment are required to update the VF-16 software.

1. IBM PC/AT compatible computer with SCSI board
2. Removable type SCSI drive
3. Cable between the removable type SCSI drive and the SCSI board
4. Cable between the removable type SCSI drive and the VF-16 (D-SUB half-pitch 50-pin)
5. A Utility software to extract the WinZip compressed file

3-2. Software Updating Procedures

Presuming that the updated software is correctly sent to you via email and is copied into your computer.

1. Connect the removable type SCSI drive to the IBM PC/AT compatible computer SCSI port.
2. Insert the diskette to the removable type SCSI drive and format it by the computer on which Windows 95/98 is running.
3. Using the utility software, extract the WinZip compressed software file. The extracted file name is "vf-16mvX.XX". (X.XX indicates the version number. For example, if the software version number is V1.04, the file name is vf-16mv1.04.)
3. Copy the updated software file "vf-16mvX.XX" to the removable type SCSI drive (diskette).
4. Set the removable type SCSI drive ID to 1 ~ 6 and connect to the VF-16 SCSI port.
5. Power on the removable type SCSI drive and then VF-16.
6. Insert the diskette with the updated software file "vf-16mvX.XX".
7. The VF-16 automatically finds the software update file in the SCSI drive/disk and is put into the software update mode. In this condition, the current software version / programming date, the updated file software version in the SCSI drive are displayed and "SURE?" blinks on the LCD. The example below indicates the condition that the V1.02 software (programming date: 00/05/09) is going to be updated to V1.04.

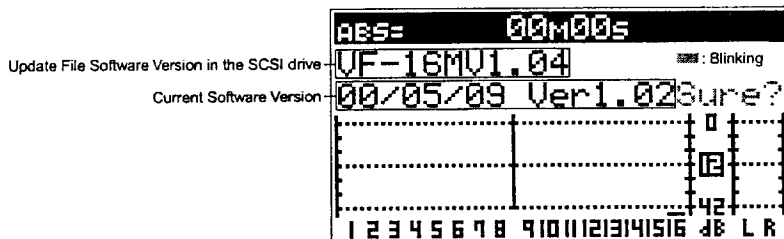

8. Press the [ENTER/YES] key to start updating the software.
9. The VF-16 LCD shows "Loading !", "Writing !", etc and after a while, the following appears on the LCD.
This indicates that the software is correctly updated. Press the [STOP] key or [EXIT/NO] key to eject the disk.

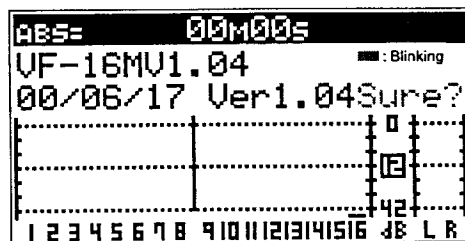

10. Power off the VF-16 and the connected SCSI drive.
11. Disconnect the SCSI drive from the VF-16 and power on the VF-16 again.
12. Confirm the software version number and the programming date while in the boot up procedures. For your information, they can also be checked by the Service Mode explained later.

4. SERVICE MODE

There are various optional modes available in the VF-16 Service Mode. Please utilize them when servicing the unit.

4-1. Putting VF-16 into Service Mode

The way of putting the VF-16 into Service Mode is as follow. (Presuming that a 3.5" HDD has already been installed and correctly formatted.)

1. Power on the VF-16.
2. While holding down the [STOP] key and [SHIFT] key, press the [SETUP] key.

Various optional menus will be displayed in addition to the general SETUP menus. Rotate the JOG dial or press the REW / F FWD key to select the desired optional mode and then press the [ENTER/YES] key while the menu is displayed.



The optional modes currently available on the VF-16 are as follow.

- Version
- DA Test
- Self Check
- Offset Display (ON/OFF)
- Initializing Disk
- Flash ROM
- Free Block Check
- Product Initialize

4-2. Flash ROM (software) version

This mode is used to check the Flash ROM (software) and CPU version currently installed on the VF-16 MAIN PCB. While selecting the service menu "Version", press the [ENTER/YES] key.

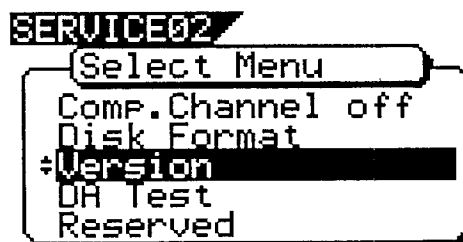

Rotating the JOG dial either C.C.W. or C.W. changes the display contents between the Flash ROM version and the CPU version.

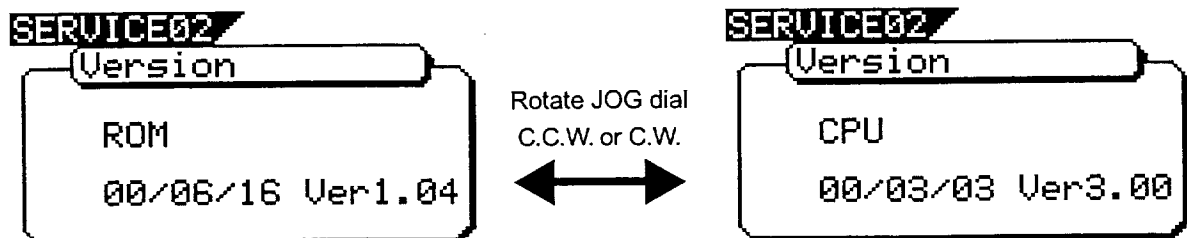

4-3. DA Test

This menu is not currently working.

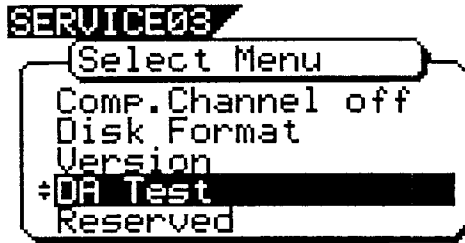

Even though the [ENTER/YES] key is pressed, the following is just displayed. To go on, press the [ENTER/YES] key.

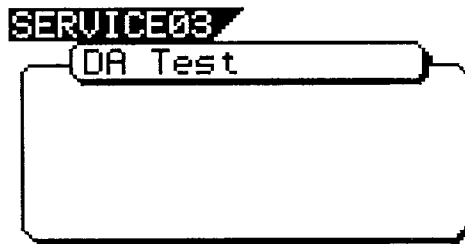

4-4. Self Check

This menu automatically tests the following points in order.

1. SCSI port → 2. ATA (E-IDE) bus → 3. MIDI in/out circuit → 4. S/P DIF digital signal in/out → 5. ADAT digital signal in/out → 6. Phantom power (+48V) → 7. A/D and D/A circuit (Input Monitor)

< Cable connection when in "SelfCheck" mode >

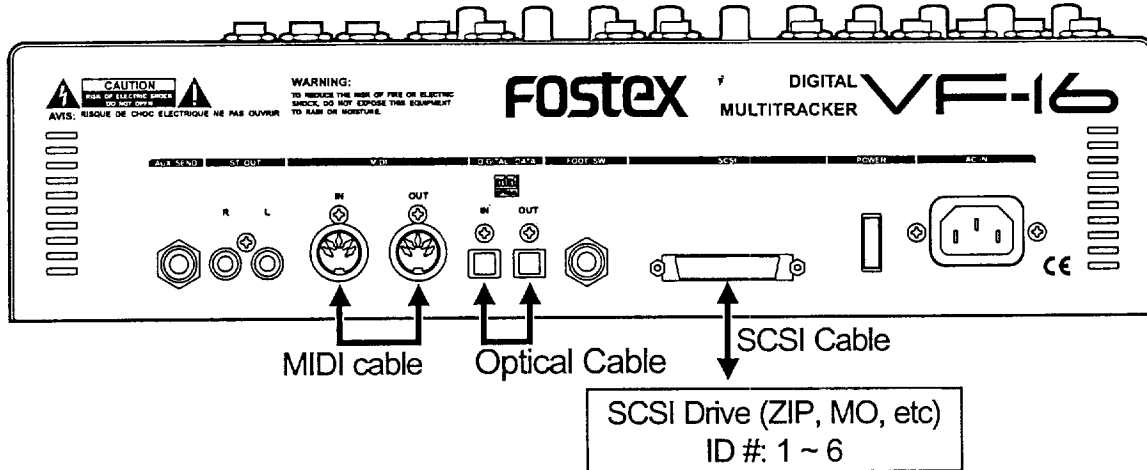

CAUTION: In order not to form a MIDI signal loop, connect the MIDI cable IN and OUT after putting the VF-16 into the Service Mode.

In order to execute the "SelfCheck" test, connect the cables and SCSI drives as shown above. Then, press the [ENTER/YES] key while the "SelfCheck" menu is selected.

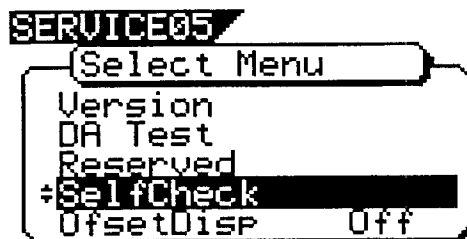

4-4-1. SCSI Port Check

If the VF-16 does not recognize a connected SCSI drive or the SCSI drive is not actually connected, the following will be displayed on the LCD.



The following will be displayed when the SCSI drive is connected properly but the disk is not put in the drive.



The following will be displayed when the disk put in the SCSI drive is not formatted.



The following will be displayed when the SCSI drive (ZIP 100 in this case) is correctly recognized.

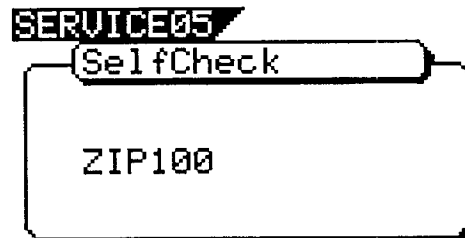

4-4-2. ATA (E-IDE) Bus Check

This test checks if data can be properly read out from the preformatted internal E-IDE hard disk.

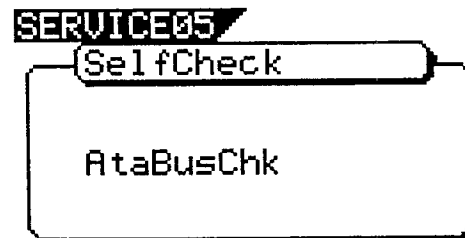

If the "ALTERNATE STATUS" indicating the hard disk condition cannot be read out correctly, the following will be displayed.



4-4-3. MIDI In/Out Check

By connecting the MIDI IN and OUT ports, this test checks if the reply against the ID inquiry is correctly received. If not, the prompt below will be displayed.



4-4-4. S/P DIF In/Out Check

By connecting the DATA IN and OUT terminals, this test checks if the S/P DIF signal output by itself is correctly received. If the PLL circuit is not in a "LOCKED" condition, the prompt below will be displayed.



4-4-5. Adat In/Out Check

By connecting the DATA IN and OUT terminals, this test checks if the ADAT digital signal output by itself is correctly received. If the PLL circuit is not in a "LOCKED" condition, the prompt below will be displayed.



4-4-6. Phantom Voltage Check

When the following is displayed, phantom power (DC +48V) is supposed to be applied between the pin-2 (HOT) and pin-1 (GND) / pin-3 (COLD) and pin-1 (GND) of XLR balanced input jack. Check the voltage between the pins using a multimeter, etc. Pressing the [ENTER/YES] key would forward the Self Check test.



4-4-7. A/D and D/A Circuit Check (Input Monitoring)

The VF-16 automatically checks the before mentioned points in the Self Check mode. If the VF-16 is working properly, the following will appear on the LCD and the VF-16 is automatically put into Input Monitoring mode.

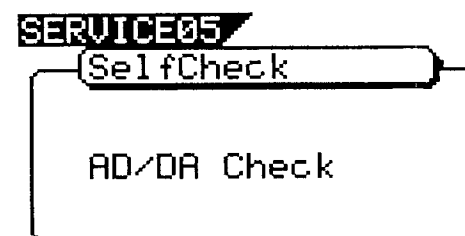

4-5. Offset Display

This mode determines if the offset value against a master machine should be displayed when the VF-16 is working as a slave machine. If you would like to turn ON the offset display, press the [ENTER/YES] key while in the following display condition. (The default setting is at "off".)



Then, turn the jog dial C.W. to change the setting to "ON" and press the [ENTER/YES] key.



This allows to display the offset value when the MTC (Select by [TIME BASE] key.) and REMAIN (Select by [DISP SEL] key.) are selected. The example below indicates that the offset value is "00H00M00S00F00SF".



4-5. Initializing Disk

This is the mode to initialize a 3.5" internal E-IDE hard disk drive or an external SCSI drive connected to the SCSI port.

CAUTION 1: If both the external SCSI drive and the internal 3.5" E-IDE hard disk drive are connected at the same time, the drive currently selected by the SETUP menu "Drive_Sel?" will be initialized.

CAUTION 2: This mode is exclusively designed for our manufacturer. To initialize the disk, use the ERASE function in the Format SETUP menu instead.



If the [ENTER/YES] key is pressed in the above display condition, the drive name to be initialized (IDE or SCSI) is displayed and "SURE?" will start blinking.



In this condition, pressing the [ENTER/YES] key one more time would initialize the recognized disk drive. This mode puts the disk back to the condition originally formatted.

4-6. Flash ROM

This mode is used when copying the system software from EPROMs to Flash ROM. As mentioned in the section “3. SOFTWARE UPDATE” (page 8), the VF-16 software inside the Flash ROM can be updated through the SCSI port. However, if something wrong happens when updating the software (e.g. A blackout occurred while updating the software.), the VF-16 might not be able to boot up using the system software inside the Flash ROM.

In this case, the following procedures must be taken.

1. Power off the VF-16 and disconnect the AC cable from the AC IN socket.
2. Plug the VF-16 EPROMs into the ROM CARD PCB assy sockets (U1 and U2). The SW on the ROM CARD PCB assy must be set to “EPROM” side.
3. Open up the top panel assy by loosening screws on both sides and on top, so that the ROM CARD PCB assy can be vertically plugged into the 50-pin connector J5 on the MAIN PCB assy.
4. Connect the AC cable and power on the VF-16.

In this condition, the VF-16 is booted up using the system software inside the EPROMs. The next procedures to take are as follows.

5. Put the VF-16 into the Service Mode, rotate the jog dial and select “FlashROM” menu.

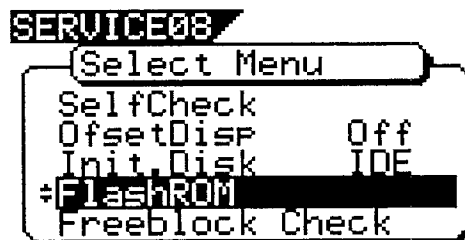

Then, press the [ENTER/YES] key.

The display indicates the following and “SURE?” will start blinking.

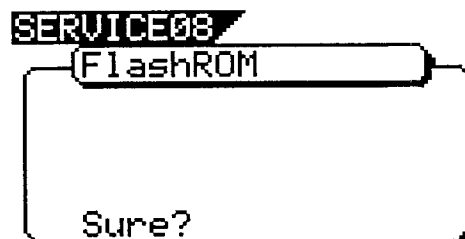

6. Press the [ENTER/YES] key to copy the system software from EPROMs to Flash ROM. The display shows “Erase ROM”, “Write ROM” and then “COMPLETED!” in order.
7. In order to confirm that the VF-16 is correctly booted up using the system software inside the Flash ROM, power off the VF-16, disconnect the ROM CARD PCB assy and power it back on again.
8. After confirming that the VF-16 is booted up using the Flash ROM, referring to the section “3. SOFTWARE UPDATE” (page 8), update the system software inside the Flash ROM through SCSI port to the latest one.

4-7. Free Block Check

This mode is used to check the condition of the diskette inserted into an external SCSI drive connected to the VF-16 or the internal E-IDE hard disk drive. The drive to be checked is the one currently selected by the SETUP menu “Drive_Sel?”.

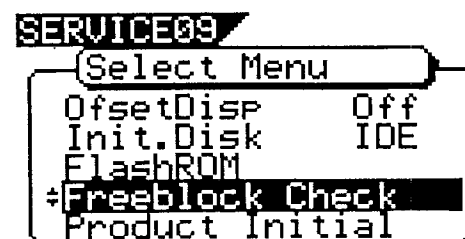

Press the [ENTER/YES] key in the above display condition. The display indicates the free audio file numbers.

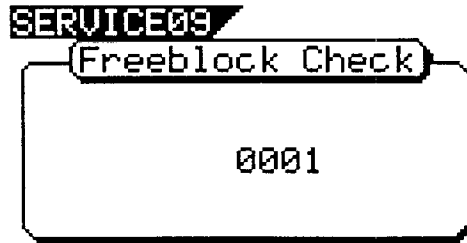

If the Free Block indicates a large number even right after formatting and no signal is recorded or if the recorded signal on the E-IDE HDD is frequently skipped, the diskette / hard disk drive can be judged to be in a bad condition.

4-8. Product Initialize

This mode is exclusively used at our assembly line and has nothing to do with servicing the unit.

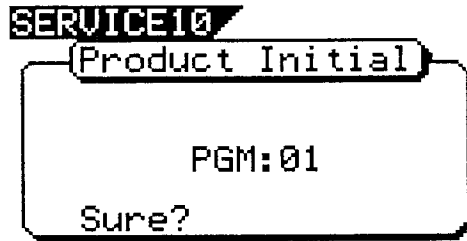

4-9. Key & LED Check Tests

These two tests are different from the before mentioned tests. It is not necessary to put the unit into the Service Mode to execute these tests.

4-9-1. Key & LED Check

This test checks in which color the LEDs on the top panel is lit and if the key is correctly pressed or not. To execute, press the CH9 (A) STATUS/CH SEL key while holding down the SHIFT and STOP keys. The LEDs are lit in the following color.

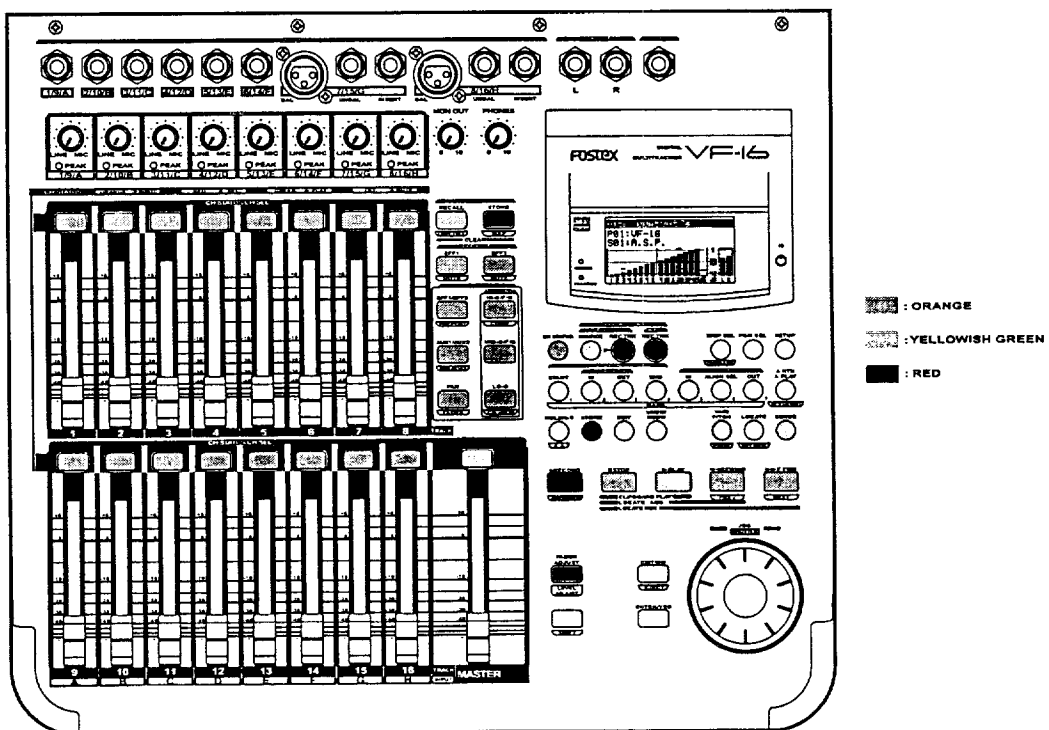

The LCD indicates the following in this mode.

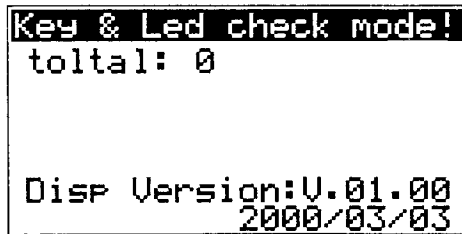

If one of the keys on the top panel is pressed, the LCD indicates the following. The message "OK" indicates that the pressed key (SW) is in good contact.

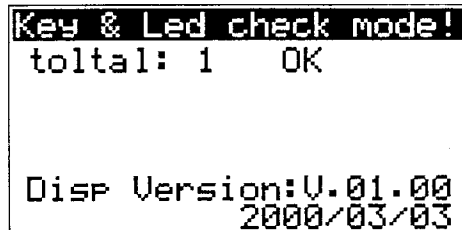

If two or more keys on the top panel are pressed at the same time, the message "ERROR" will be displayed on the LCD. In the meantime, the names of the pressed keys are displayed. The example below indicates that the [RECORD] and [PLAY] keys are pressed at the same time.

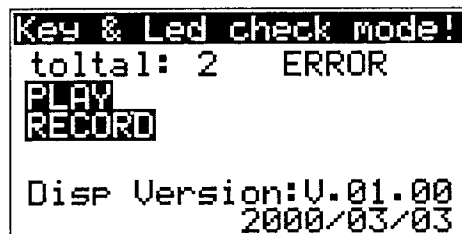

To get out of the test mode, press the MASTER key while holding down the SHIFT and STOP keys.

4-9-2. LED Check 2

This test checks in which (orange / yellowish green / red) color the LEDs on the top panel are lit. Especially the CH STATUS/CH SEL keys are lit in different color depending on the recording mode, etc. To execute, press the CH10 (B) STATUS/CH SEL key while holding down the SHIFT and STOP keys. No LED is lit right after the VF-16 is put into this test. Then, every time the [ENTER/YES] key is pressed, the orange, yellowish green and red LEDs are lit in order.

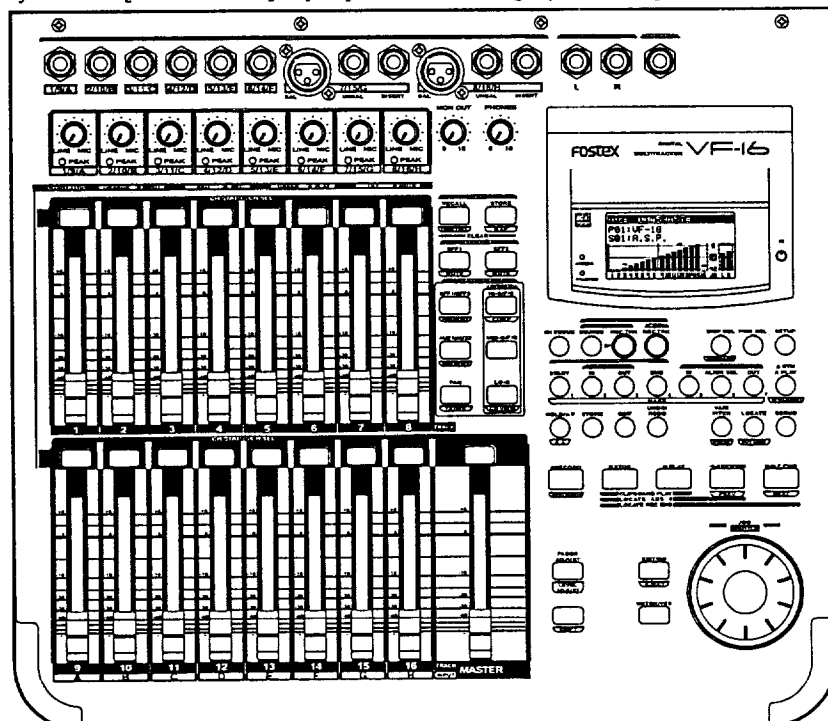



Press the ENTER/YES key.

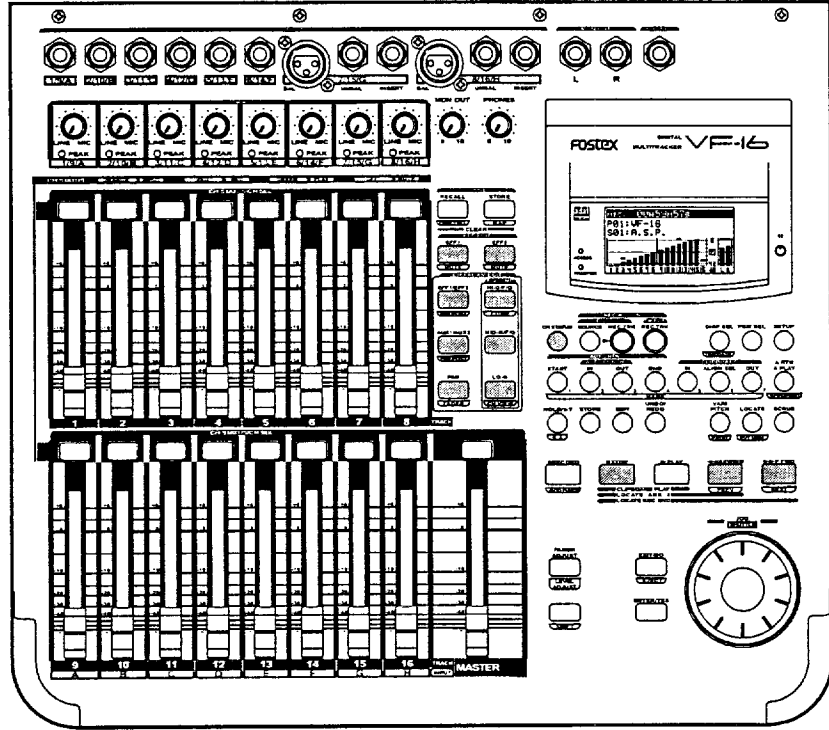

 : ORANGE



Press the ENTER/YES key.

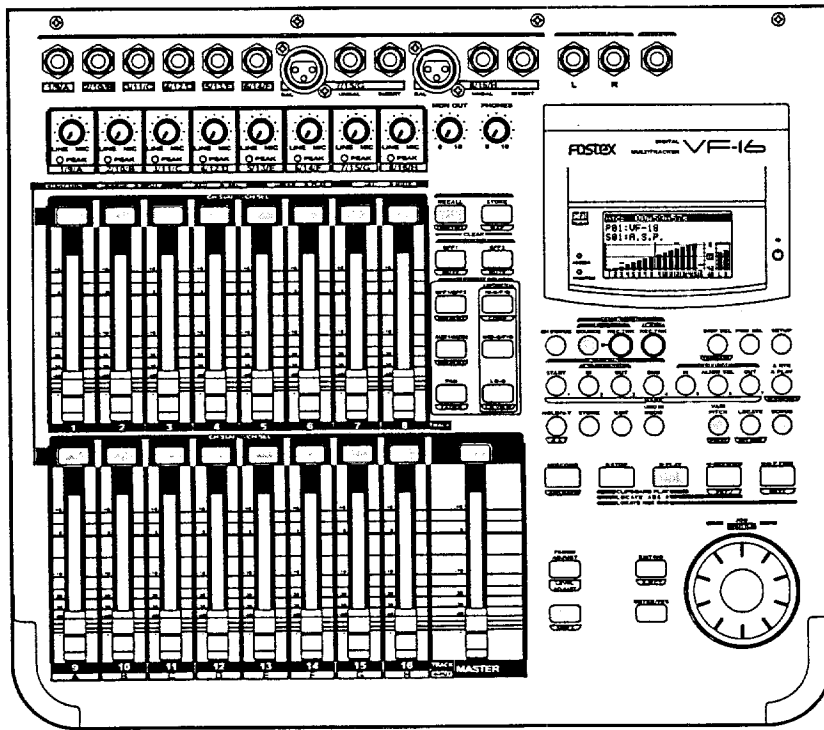

 : YELLOWISH GREEN



Press the ENTER/YES key.

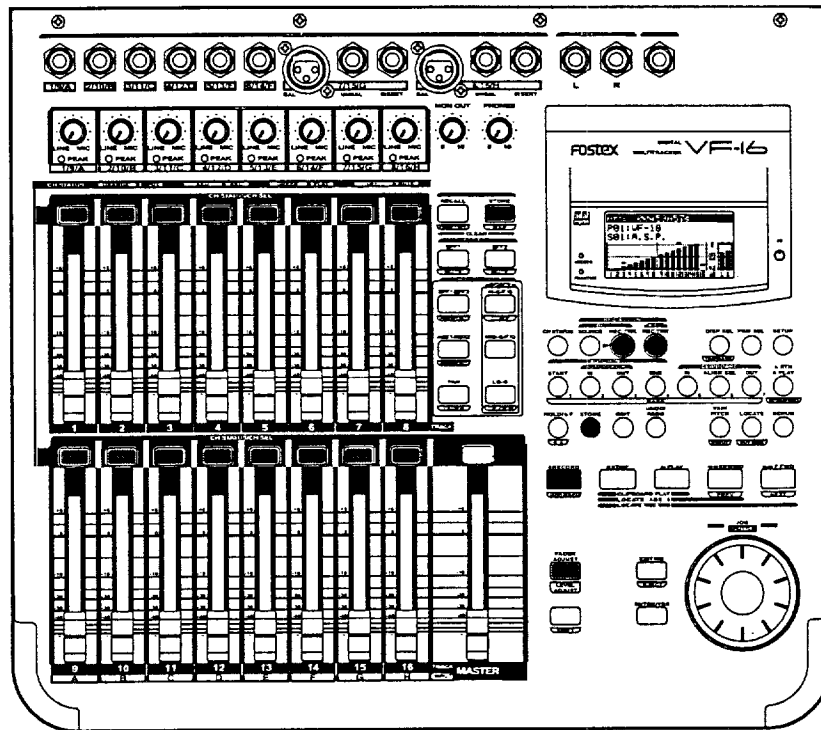

To get out of the test mode, press the MASTER key while holding down the [SHIFT] and [STOP] keys.

5. ERROR CODE LIST

The chart below indicates the error code number and corresponding description. Since the error code list is basically designed for our engineers to improve the software, the description is quite technical. If you find the VF-16 with one of the error codes displayed, we encourage you to update the software to the latest one first. In case updating the software does not solve the problem, we would like you to inform us about details.

VF-16 ERROR CODE LIST	
ERROR CODE	DESCRIPTION
1	VF-16 tries to access the address which does not exist.
3	SCSI drive does not boot up correctly during SCSI drive access operation When saving system region sector, its address is registered in Free_block File during Free block File checking procedure.
10	Link_pointer which links Audio File indicates smaller address (out of region) than Link_File address region in RAM.
11	Link_pointer indicates larger address (out of region) than Link_File address region in RAM.
12	"Pointer_adre" calculation of Link_Pointer is not correct.
14	Link_Pointer during recording/reproducing indicates smaller address (out of region) than actual Link_File address region.
15	Link_Pointer during recording/reproducing indicates larger address (out of region) than actual Link_File address region.
16	"Pointer_adre" calculation of Link_Pointer during recording/reproducing is not correct.
20	src_cash_load: Improper access of link address occurred while PASTE editing.
21	bak_cash_load: Program link during PASTE/MOVE editing is incorrect.
22	bak_cash_load: Incompatibility problem occurred on program link during PASTE/MOVE editing.
30	Error when executing MOVE editing. Improper Link Pointer. Error in "bak_cash_load" function.
31	Error when executing MOVE editing. Improper Link Pointer. Error in "bak_cash_load" function.
32	Error when executing MOVE editing. Improper Link Pointer. Error in "bak_cash_load" function.
39	This error code is displayed when reading / writing test in Self Check mode fails.
40	dis_cah_load: Improper access occurred when recording/reproducing.
41	dis_cah_load: Improper access occurred when recording/reproducing.
42	dis_cah_load: Improper access occurred when recording/reproducing.
45	get_non_des_block: Remaining disk capacity is insufficient.
52	non_des_cash_save_sub: Improper access occurred when recording/reproducing.
60	remake_free_block: There was improper access to program management region.
61	remake_free_block: There was improper access to program management region.
62	remake_free_block: Number of manageable events exceeds limit.
63	remake_free_block: There was improper access to program management region.
64	remake_free_block: There is an overlapping section in program management region.
96	There was improper access to program management region.
97	There was improper access to program management region when saving System File.
99	There was improper access when fading in/out.

6. EXPLODED VIEW, PCB ASSEMBLY & PARTS LIST

● VF-16 OVERALL EXPLODED VIEW & PARTS LIST

Ref. No.	Part No.	Description	Ref. No.	Part No.	Description
1	8270 8820 51	Hard disk assy, IDE, 3.5", 5.1GB	26	8204 0090 01	Spacer, M3 x 5
2	8221 3331 00	Panel, top, VF-16	27	8212 6590 03	Pad, side, L, N19
3	8212 6910 00	Window, LCD, VF-16	28	8212 6590 04	Pad, side, R, N19
4	8212 6950 00	Panel, LCD, VF-16	29	8218 2630 00	Sticker, GND
5	8260 5740 00	LCD assy, VF-16	30	8216 7400 00	Sheet, isolation, VF-16
6	8221 3130 00	Bracket, LCD, VF-16	31	8214 3950 00	Spring, jog, VM88/VF-16
7	8274 2550 00	PCB assy, Key, VF-16	32	8226 2230 01	Knob, volume, C
8	8207 0117 01	Holder, cord, CS-1	33	8226 2490 03	Knob, fader, N19
9	8212 6920 00	Plate, reflect, LCD, VF-16	34	8226 2490 02	Knob, fader, R
10	8216 7330 00	Sheet, LCD, VF-16	35	8226 2630 00	Button assy, control, VF-16
11	8221 3340 00	Bracket, PCB, VF-16	36	8226 2620 00	Knob, jog, VF-16
12	8274 2790 00	PCB assy, Key 2, VF-16	37	8226 2460 01	Button, 7 x 13, LED
13	8274 2530 00	PCB assy, Mic/Mon, VF-16	38	8226 0130 02	Button, push, B
14	8274 2770 00	PCB assy, Peak, VF-16	△ 39	8276 8010 00	Cord, power, UL/CSA, VM0033-0089, USA/CSA/CND
△ 15	8274 2540 00	PCB assy, Main, VF-16		8276 8021 00	Cord, power, CEE, 0309B-0310B, EUR
16	8221 2610 00	Bracket, AC-IN, FD-8/VF-16		8276 8000 00	Cord, power, DM, VM1292-1298, JPN
17	8245 3400 00	Nut, phone jack		8276 9170 00	Cord, power, BS, 3C, KP610-KS31A, UK
18	8276 8396 30	Cable, flat, FFC, 17P, L300	40	8218 7100 00	Label, screw
19	8221 3110 00	Panel, bottom, VF-16	41	8218 0160 00	Label, fuse, caution
20	8221 1930 00	Cover, HD, DMT-8VL/VF-16	42	N/A	(Comes with phone jack)
21	8221 3350 00	Shield, power, VF-16	43	N/A	(Comes with phone jack)
22	8221 3372 00	Chassis, VF-16			
23	8207 0047 01	Plastic rivet, #1C18			
24	8207 0120 00	Foot, FF-822			
25	8207 0046 04	Spacer, PCB, 5RT			

● VF-16 OVERALL EXPLODED VIEW & PARTS LIST

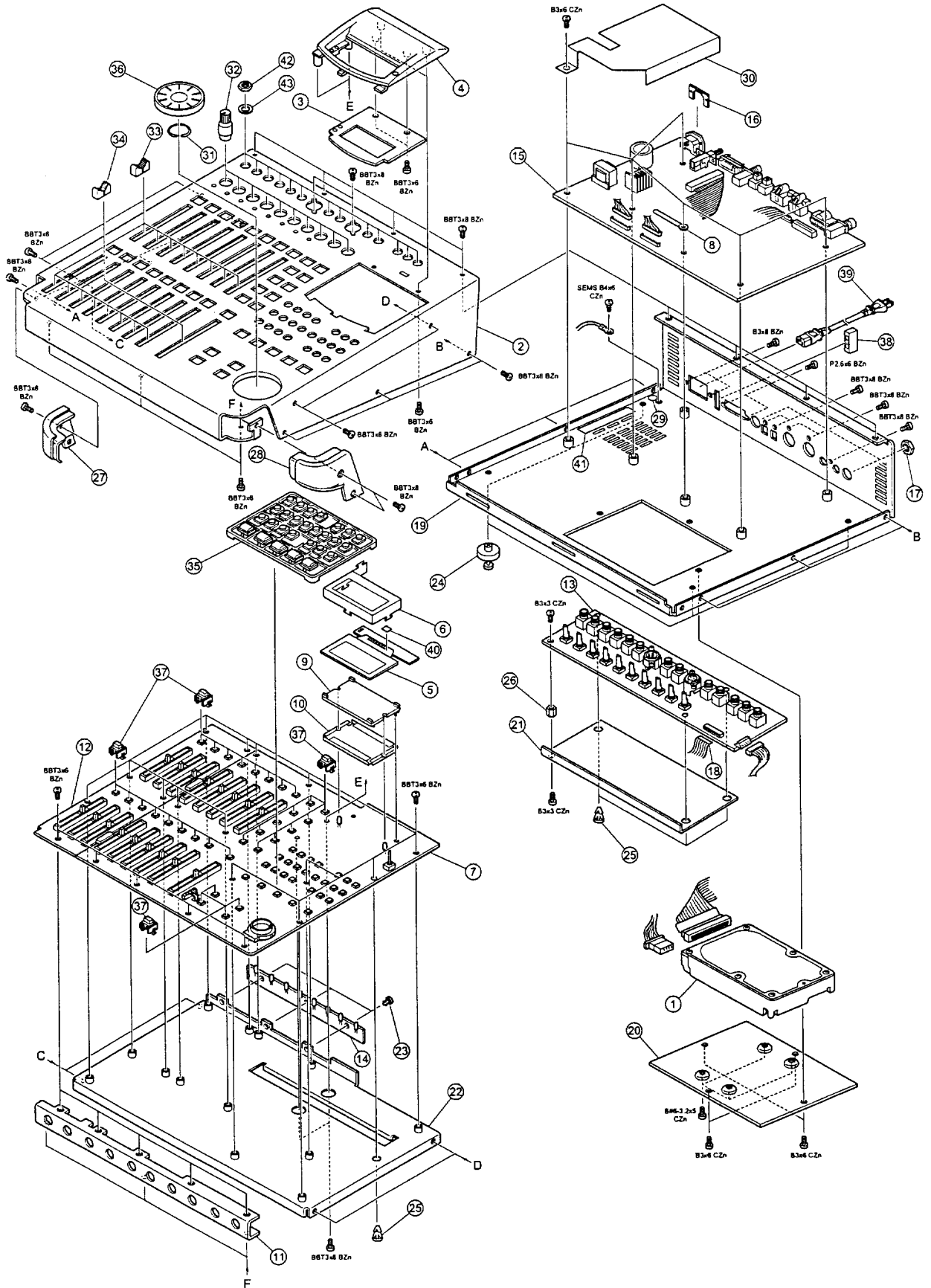

- VF-16 PCB ASSEMBLIES
- Parts Side of MAIN PCB

