

# POWERCASE 12 POWERCASE 16

**AMPLIFIED STEREO MIXER**

## SERVICE MANUAL Schematic Diagrams



CODE : 277082



## Index & Warnings

Technical Specifications & Block Diagram	2
Interconnections System (POWERCASE 12ch)	3
Interconnections System (POWERCASE 16ch)	4
Power Amplifier & Supply Board (POWERCASE 12ch)	5
Power Amplifier & Supply Board (POWERCASE 16ch)	6
Main Board (1/2) - 4 XLR Inputs Board - Master Output Board (POWERCASE 12ch)	7
Main Board (2/2)	8
Main Board (1/2) - 8 XLR Inputs Board - Master Output Board (POWERCASE 16ch)	9
Main Board (2/2)	10
Digital Reverb Board (III Ver.)	11
Spare Parts List	12

GENERALMUSIC S.p.A. Sales Division: 47048 S.Giovanni in Marignano (RN) ITALY - Via delle Rose, 12 - tel. 0541/959511 - Ix 550555 GMUSIC I - fax 0541/957404



### Notice

Service must be carried out by qualified personnel only. Any tampering carried out by unqualified personnel during the guarantee period will forfeit the right to guarantee.

For a correct operation of the instrument, after having switched off, be careful to wait at least 3 seconds before switching on again. To improve the device's specifications, the schematic diagrams may be subject to change without prior notice.

### Schematic Notes

△ All components marked by this symbol have special safety characteristics, when replacing any of these components use only manufacturer's specified parts.

The (μ) micro symbol of capacitance value is substituted by U. The (Ω) omega symbol of resistance value is substituted by E. The electrolytic capacitors are 25Vdc rated voltage unless otherwise specified. All resistors are 1/8W unless otherwise specified. All switches shown in the "OFF" position. All DC voltages measured to ground with a voltmeter 20KOhm/V.

- |   |                         |
|---|-------------------------|
| ← Soldering point.  | ↑ Supply voltage.       |
| • Male connector.   | ⬇ Logic supply ground.  |
| ○ Female connector.   | ⬇ Analog supply ground. |
| ⊖ M/F faston connector.   | ↓ Signal ground.        |
| □ Test point.   | ⊕ Chassis ground.       |
| ⊖ Flag joined with one or more flags with the same signal name inscribed. |                         |



### ATTENTION

Observe precautions when handling electrostatic sensitive devices

SECTION	LEVEL & DATA
<b>INPUT CHANNELS</b>	
MONO channel MIC input	sensitivity from -20dB to -50dB gain 30dB impedance 1.2KΩ
MONO channel LINE input	sensitivity from +10dB to -20dB gain 30dB impedance 10KΩ
STEREO channel	sensitivity from +10dB to -30dB gain 40dB impedance 45KΩ
EQ HIGH	±15dB 10kHz (Shelving)
EQ MID	±15dB 1kHz (Peaking)
EQ LOW	±15dB 70kHz Shelving)
<b>MASTER</b>	
LINE OUT (L&R)	+4dB
MONITOR OUT	+4dB

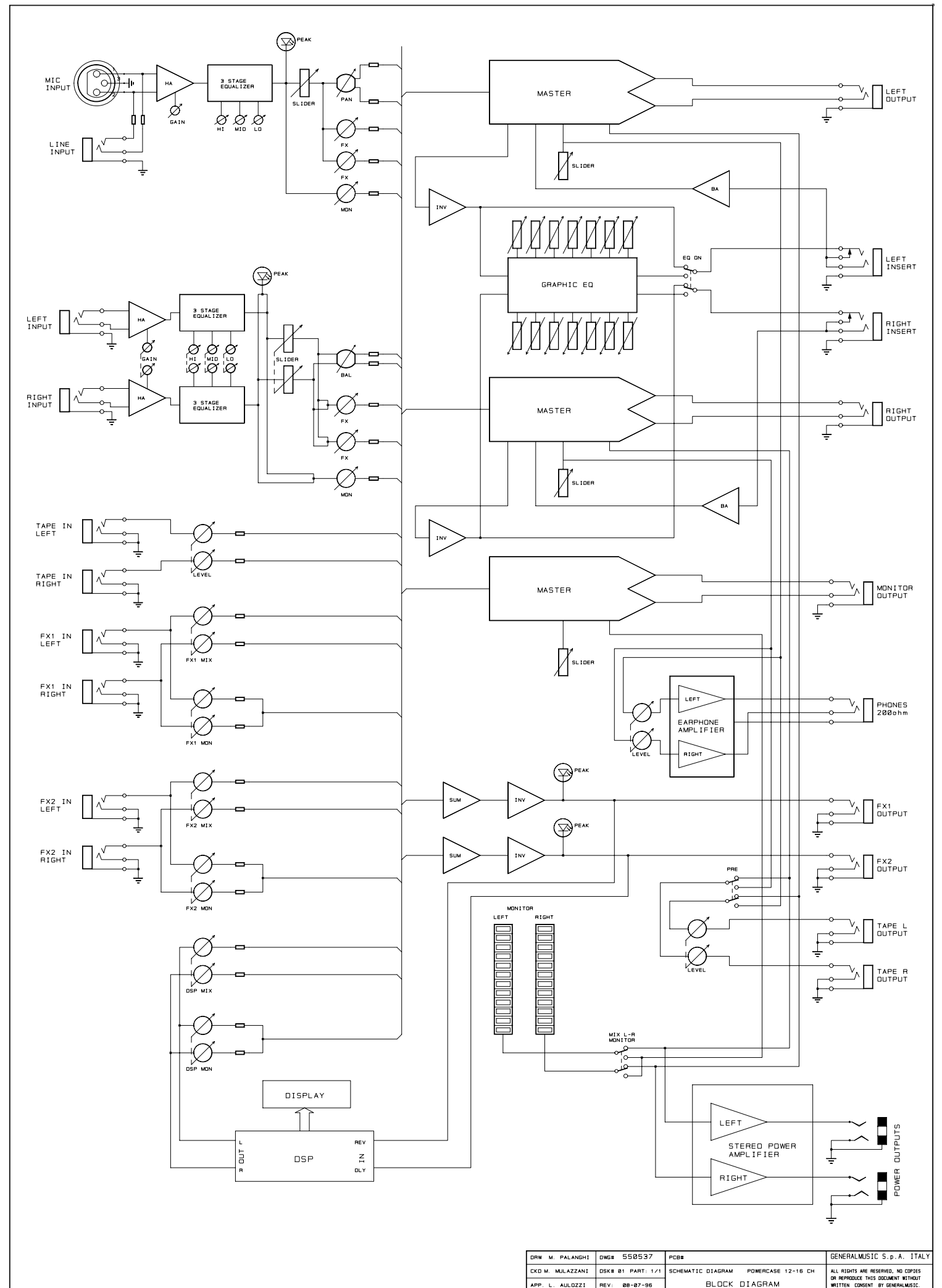

DRW: M. PALANGHI	DWG#: 550537	PCBR	GENERALMUSIC S.p.A. ITALY
CKD: M. MIAZZANI	DSK#: 01 PART: 1/1	SCHEMATIC DIAGRAM	POWERCASE 12-16 CH
APP: L. AULDZANI	REV: 08-07-96	BLOCK DIAGRAM	ALL RIGHTS ARE RESERVED. NO COPIES OR REPRODUCTIONS WITHOUT WRITTEN CONSENT BY GENERALMUSIC.

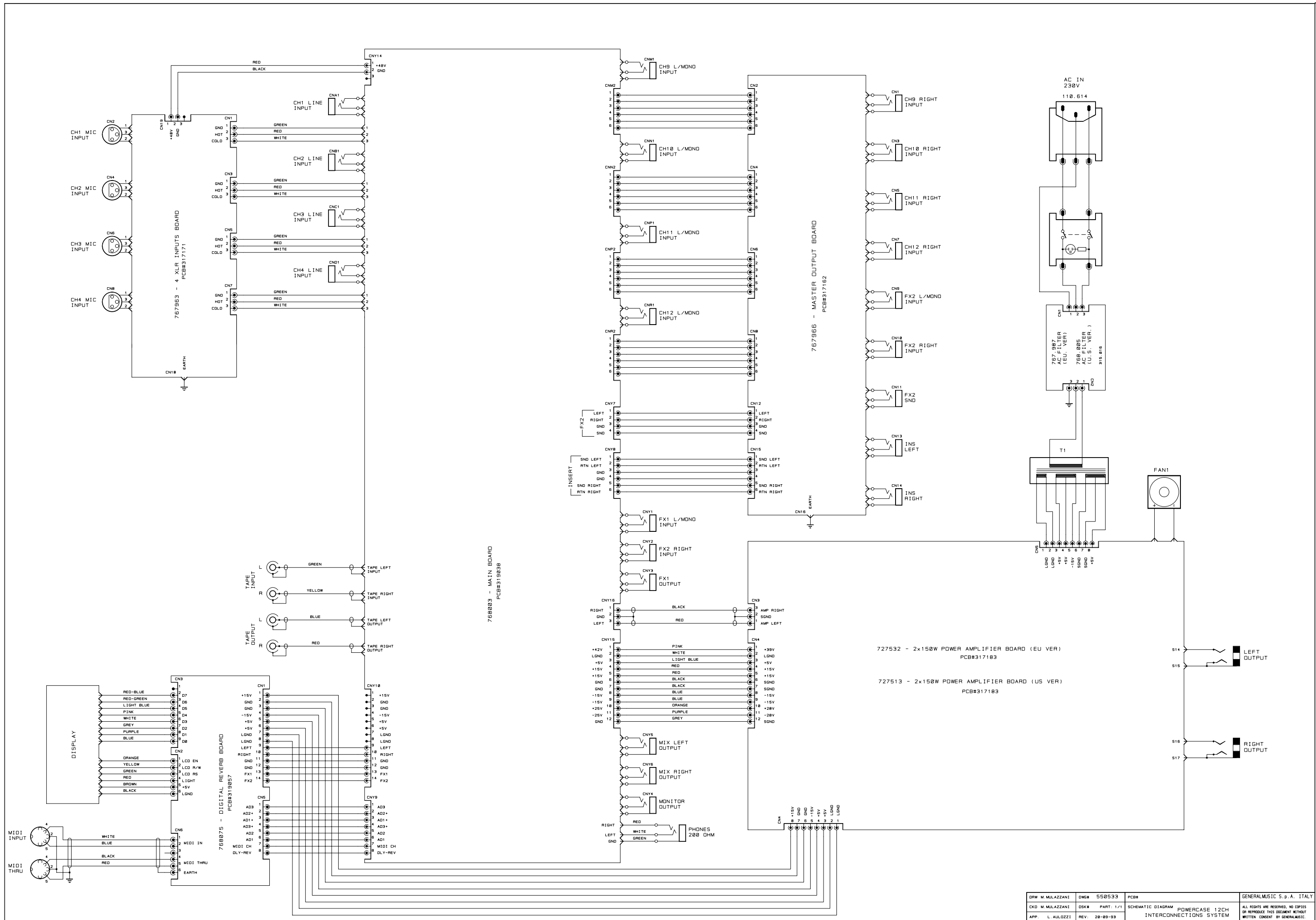

DRW: M. MALAZZANI	DWG#: 558533	PCB#	GENERALMUSIC S.p.A. ITALY
CKD: M. MALAZZANI	DSK# PART: 1/1	SCHMATIC DIAGRAM	ALL RIGHTS ARE RESERVED. NO COPIES OR REPRODUCTIONS OF THIS DOCUMENT WITHOUT WRITTEN CONSENT BY GENERALMUSIC.
APP: L. AULOZZI	REV: 28-89-93	POWERCASE 12CH INTERCONNECTIONS SYSTEM	

767998 - 2 x 150W POWER AMPLIFIER BOARD (EU VER)  
 768001 - 2 x 150W POWER AMPLIFIER BOARD (US VER)

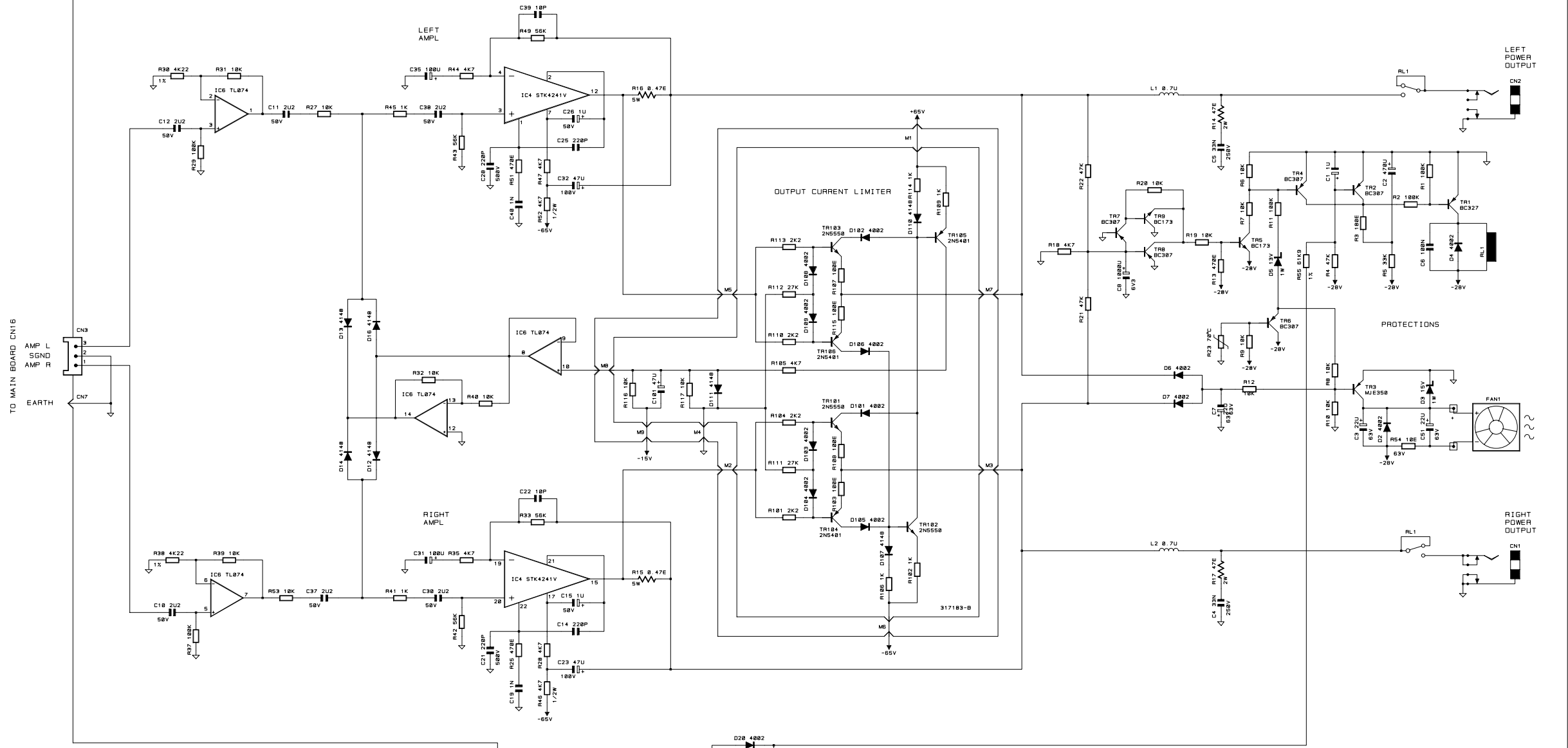

230VAC +/-20% 50Hz  
 117VAC +/-20% 60Hz

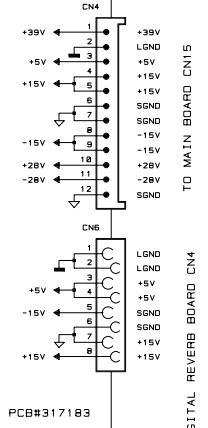
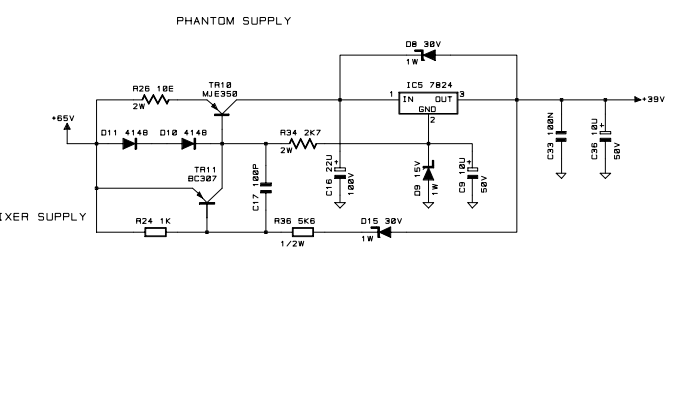
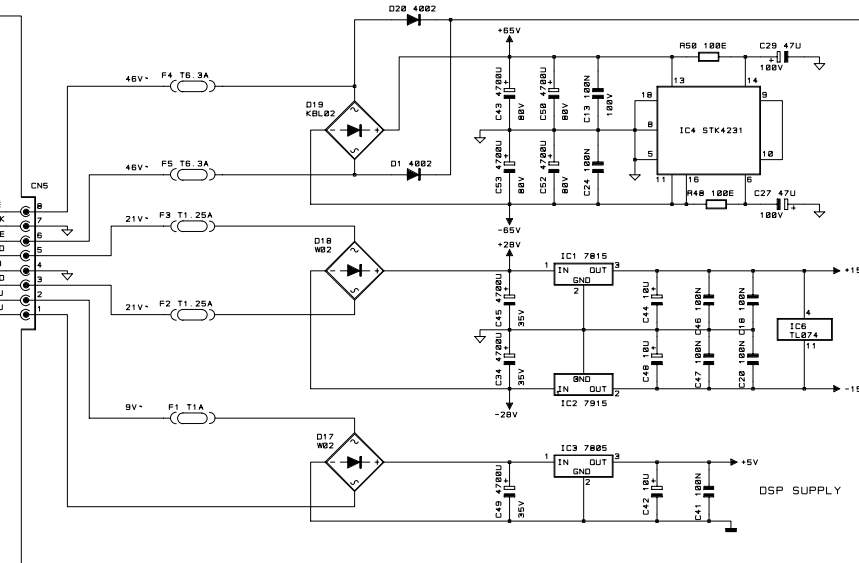
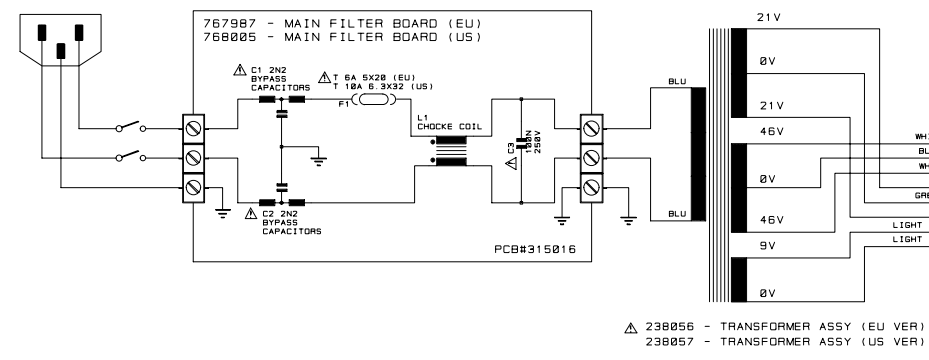

- NOTES :
- 1) ALL RESISTORS ARE 1/4W 5% UNLESS OTHERWISE SPECIFIED
  - 2) ALL CERAMIC CAPACITORS ARE 50V 18% UNLESS OTHERWISE SPECIFIED
  - 3) ALL POLYESTER CAPACITORS ARE 63V 18% UNLESS OTHERWISE SPECIFIED
  - 4) ALL VOLTAGES ARE MEASURED TO GROUND + NOMINAL MAIN VOLTAGE WITH 20K1/V METER

DRW M. PALANGHI	DWG# 558535	PRINTED CIRCUIT CODE :	317183	GENERALMUSIC S.p.A. ITALY
CKD G. RICCI	DISK: PART:	SCHEMATIC DIAGRAM	POWERCASE 12	ALL RIGHTS ARE RESERVED. NO COPIES OR REPRODUCE THIS DOCUMENT WITHOUT WRITTEN CONSENT BY GENERALMUSIC.
APP. I. BATELLI	REV:	2x150W POWER AMPLIFIER BOARD		

768003 - MAIN BOARD (POWERCASE/SOUNDCASE 12CH)

767966 - MASTER OUTPUTS BOARD

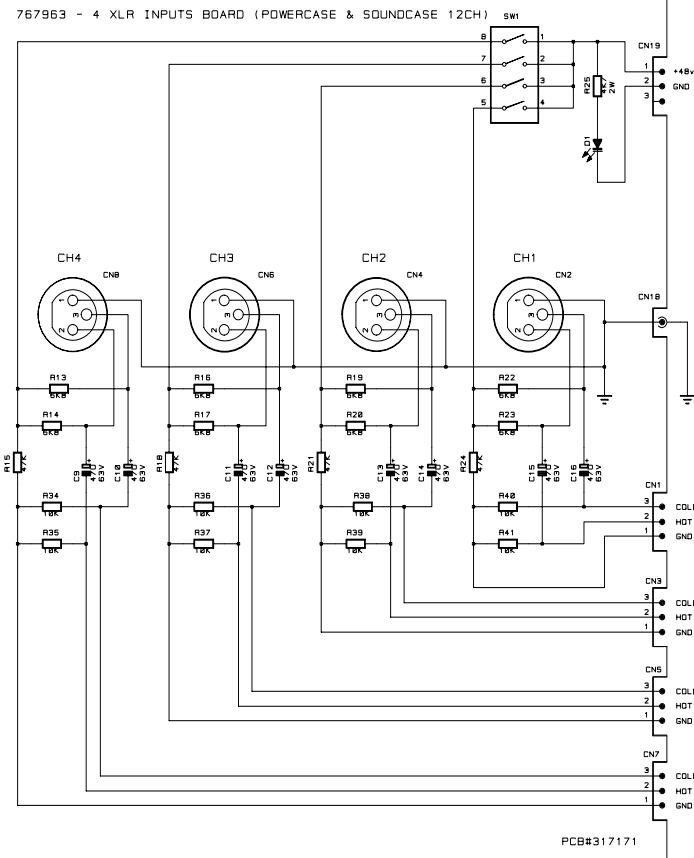
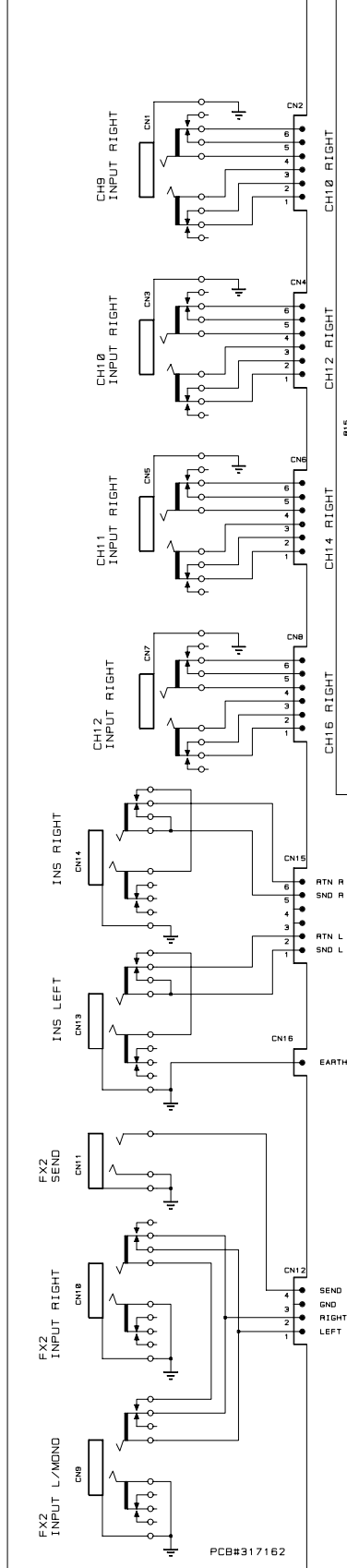

CH1 MIC INPUT  
SENSITIVITY  
-20dB -50dB

CH1 LINE INPUT  
SENSITIVITY  
+10dB -20dB

CH2 INPUT SENSITIVITY  
+10dB -40dB

CH6 INPUT RIGHT

CH7 (STEREO)  
CH8 (STEREO)  
CH9 CH10 (STEREO)  
CH11 (STEREO)  
CH12 (STEREO)

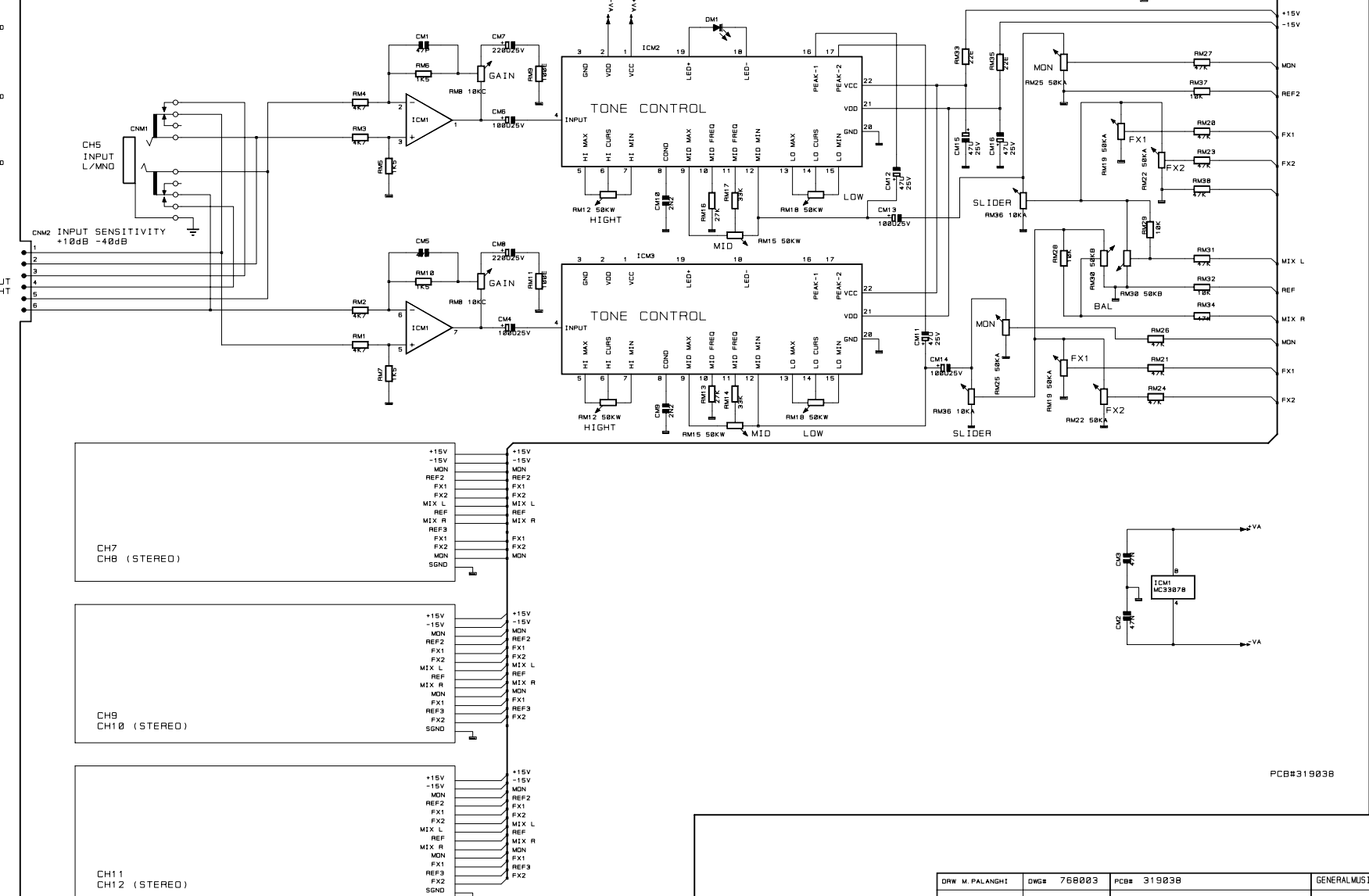

DRW M. PALANGHI	DWG# 768003	PCB# 319038	GENERALMUSIC S.p.A. ITALY
CKD M. MULLAZZANI	DSK# PART: 1/2	SCHEMATIC DIAGRAM MAIN BOARD	ALL RIGHTS ARE RESERVED. NO COPIES
APP. L. AILDEZZI	REV: 03-07-96	POWERCASE/SOUNDCASE 12CH	OR REPRODUCE THIS DOCUMENT WITHOUT
			WRITTEN CONSENT BY GENERALMUSIC

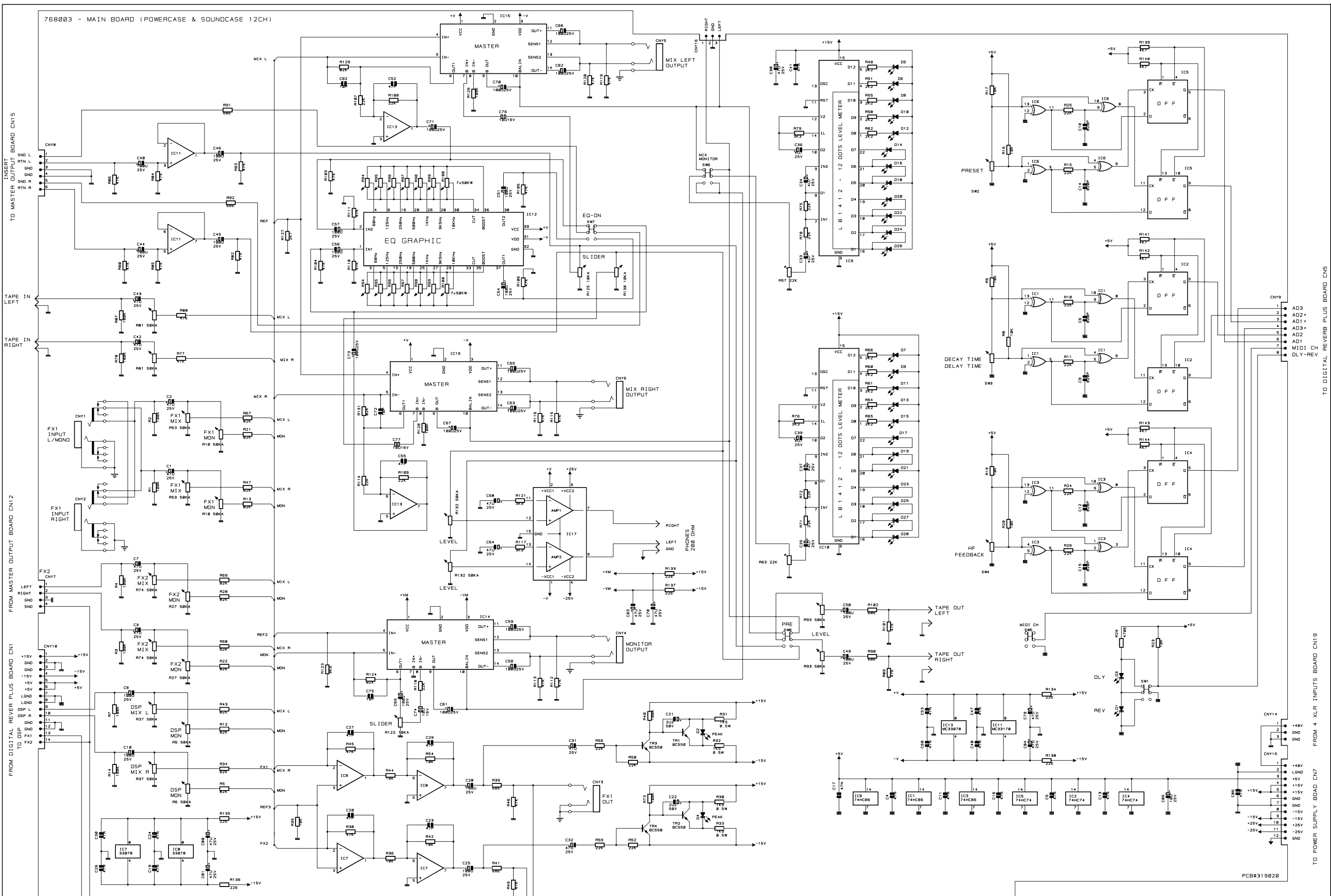

DRW. M. PALANGHI	DSK# 550526	PCB#	GENERALMUSIC S.p.A. ITALY
CKD M. M.LAZZANI	DSK# PART. 2/2	SCHEMATIC DIAGRAM	ALL RIGHTS ARE RESERVED. NO COPIES
APP. L. AULOZZI	REV. 30-11-93	MAIN BOARD	OR REPRODUCE THIS DOCUMENT WITHOUT
		POWERCASE-SOUNDCASE 12CH	WRITTEN CONSENT BY GENERALMUSIC.

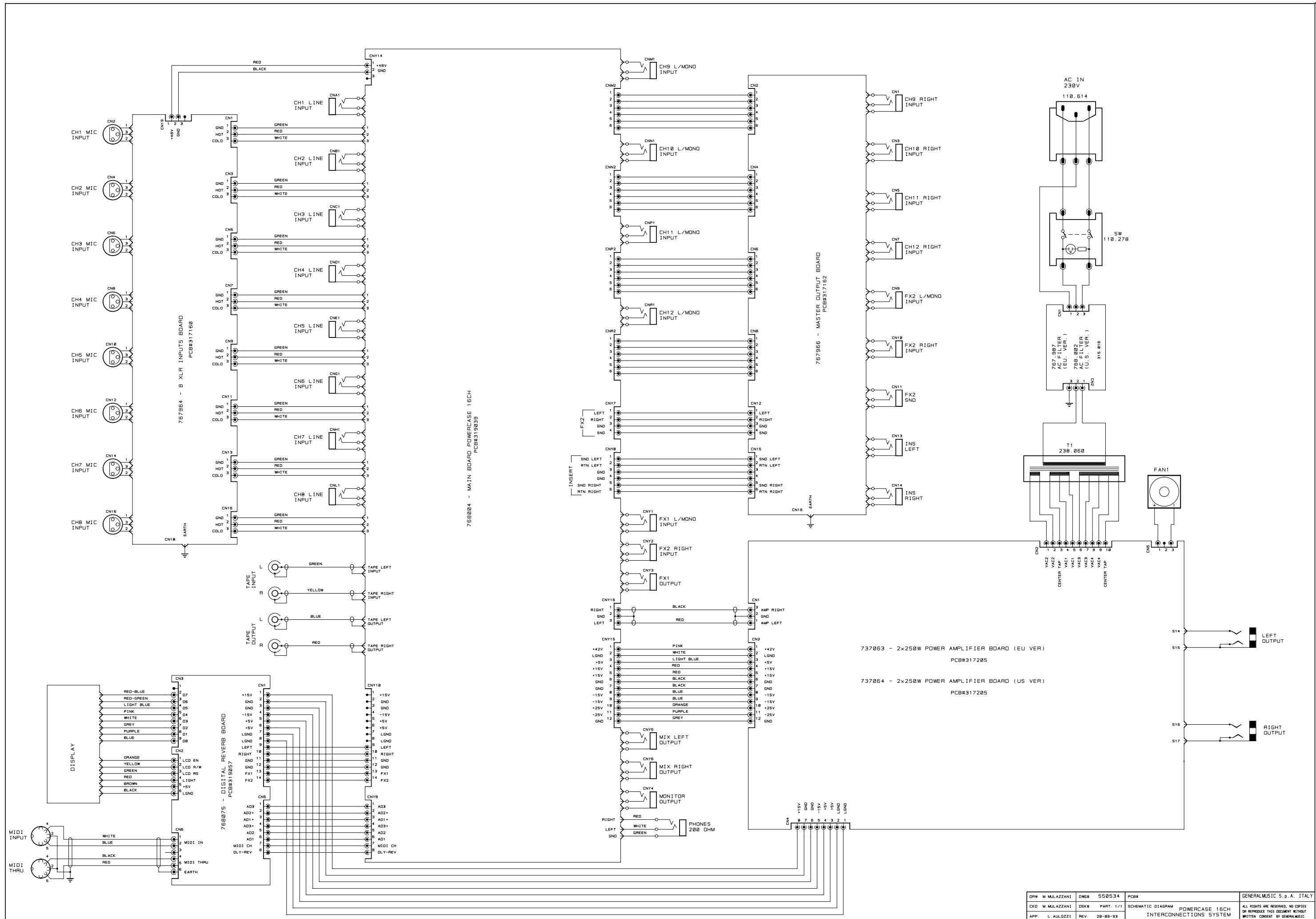

DRW	M. MULLAZZANI	DWG#	550534	PCB#		GENERALMUSIC S.p.A. ITALY
CKD	M. MULLAZZANI	DSK#	PART: 1/1	SCHEMATIC DIAGRAM POWERCASE 16CH INTERCONNECTIONS SYSTEM		ALL RIGHTS ARE RESERVED. NO COPIES OR REPRODUCTIONS OF THIS DOCUMENT WITHOUT WRITTEN CONSENT BY GENERALMUSIC.
APP.	L. AULOZZI	REV.	28-09-93			

768067 - 2x250W POWER AMPLIFIERS BOARD

768067 - POWER SUPPLIES & PROTECTIONS BOARD

TO MAIN BOARD CN16

TO MAIN BOARD CN15

TO DIGITAL REVERB BOARD CN1

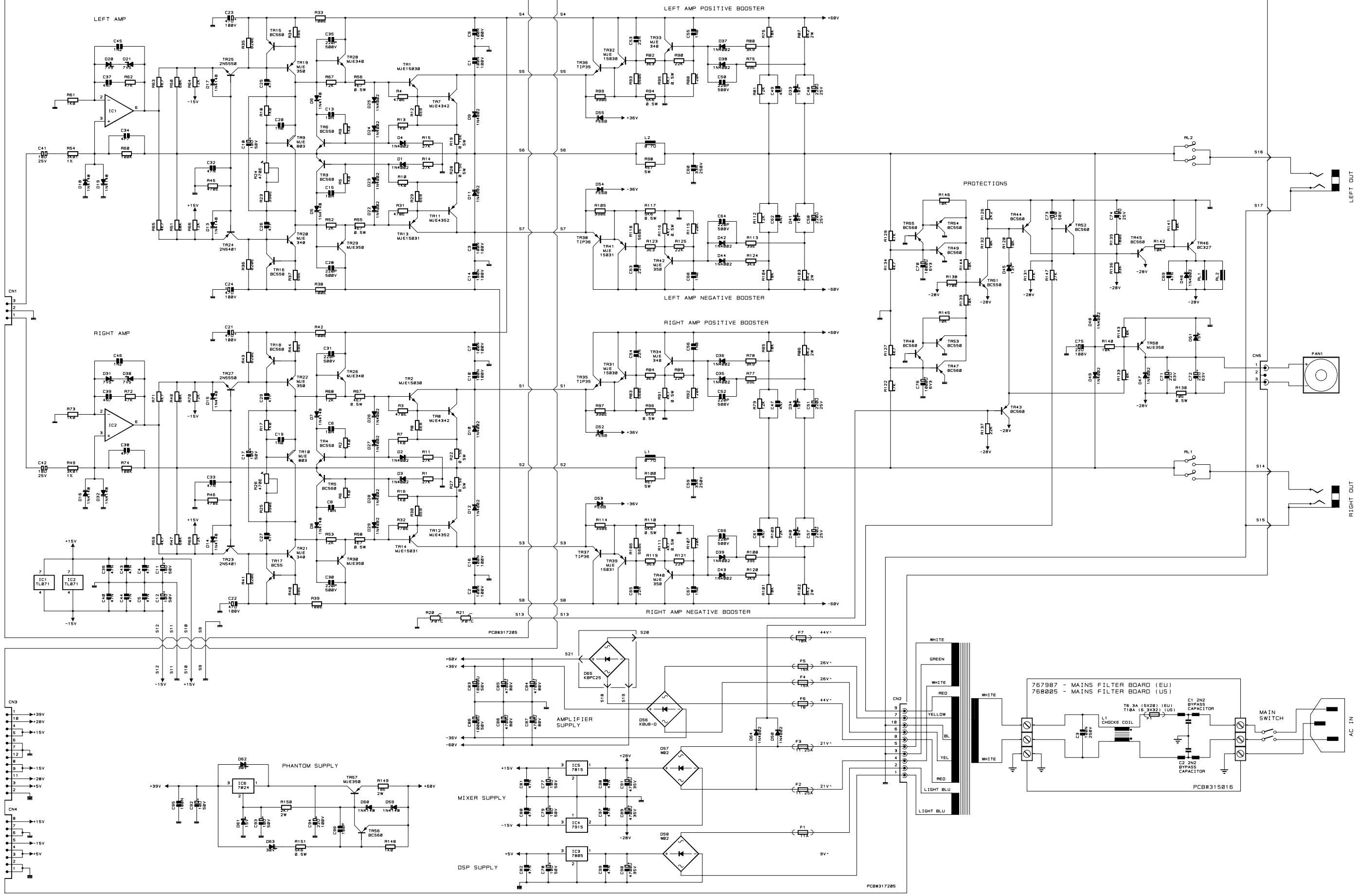

DRW M. PALANGHI	DNW 550536	PCB#	GENERALMUSIC S.p.A. ITALY
CKD G. RICCI	DSKB PART: 1/1	SCHEMATIC DIAGRAM	ALL RIGHTS ARE RESERVED. NO COPIES OR REPRODUCE THIS DOCUMENT WITHOUT WRITTEN CONSENT BY GENERALMUSIC.
APP: I. BATTELLI	REV: 28/08/1994	2X250W POWER AMPLIFIER BOARD	



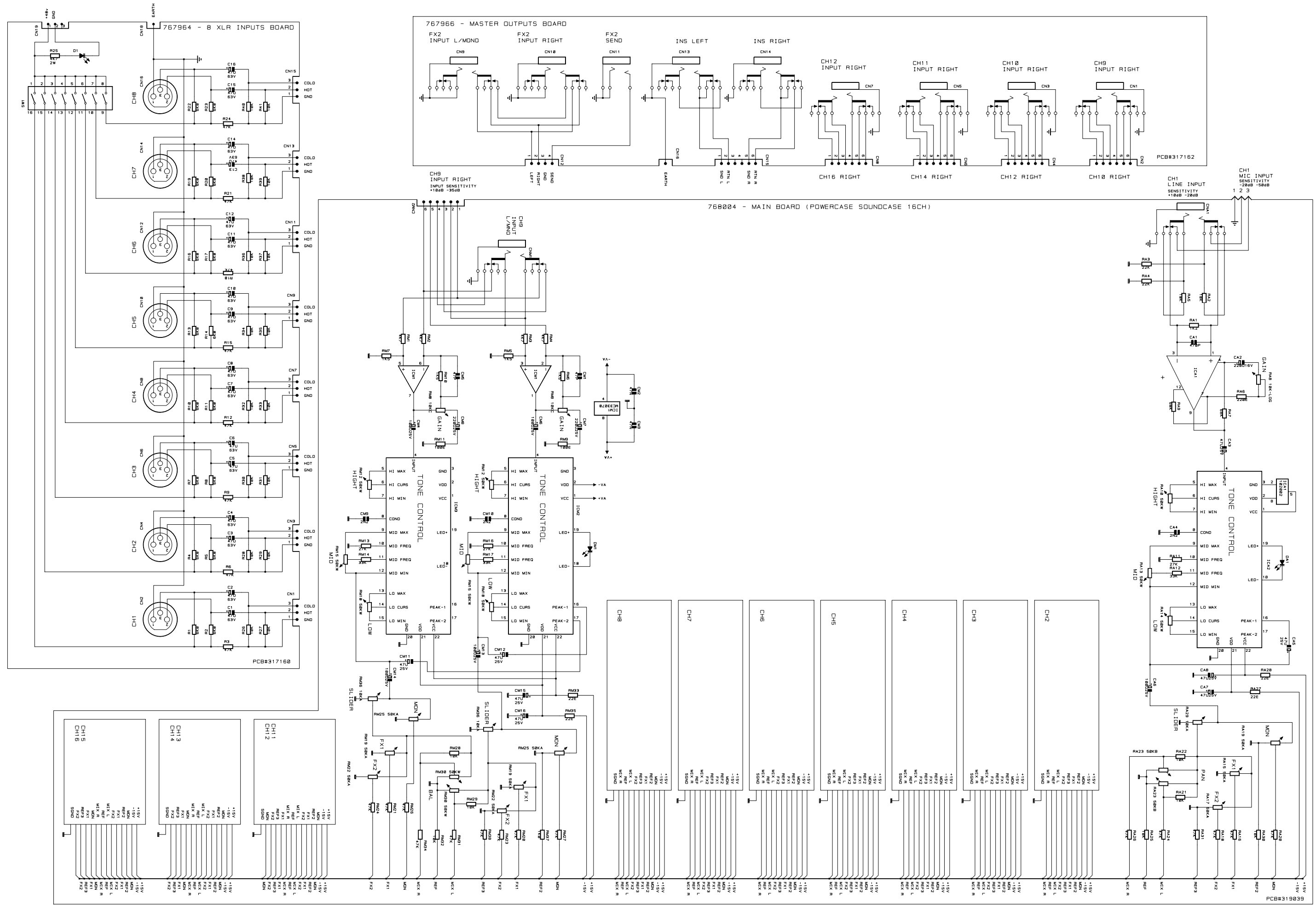

DRW	M. MALAZZANI	DSK#	767962	PCBR		GENERALMUSIC S.p.A. ITALY
CKD	M. MALAZZANI	SK#		SCHEMATIC DIAGRAM	MAIN BOARD	ALL RIGHTS ARE RESERVED. NO COPIES OR REPRODUCTIONS OF THIS DOCUMENT WITHOUT WRITTEN CONSENT BY GENERALMUSIC.
APP.	L. AULOZZI	REV.	38-11-93	POWERCASE SOUND CASE 16CH		

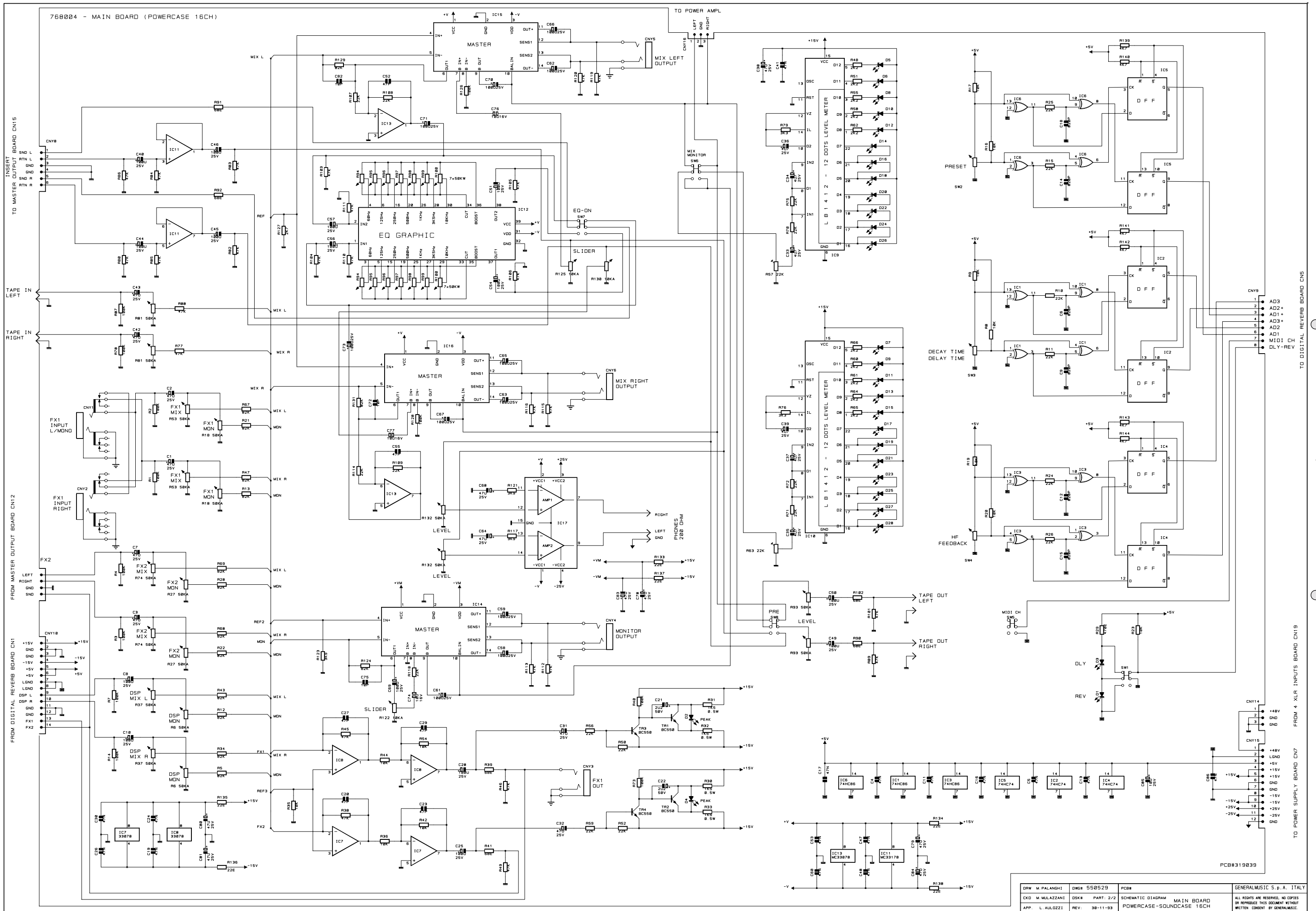

DRW M. PALANGHI	DWG 550529	PCBR	GENERALMUSIC S.p.A. ITALY
CKD M. LAZZANI	DSER	PART: 2/2	ALL RIGHTS ARE RESERVED. NO COPIES OR REPRODUCTIONS OF THIS DOCUMENT WITHOUT WRITTEN CONSENT BY GENERALMUSIC
APP. L. LAZZANI	REV. 30-11-93	SCHEMATIC DIAGRAM MAIN BOARD POWERCASE-SOUNDCASE 16CH	

768075 - DIGITAL REVERB PLUS BOARD

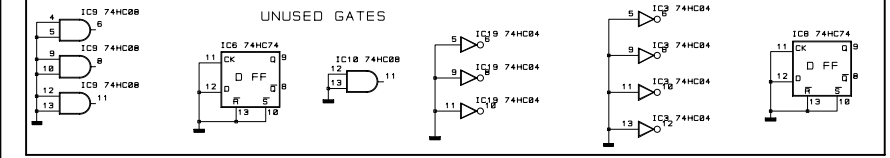
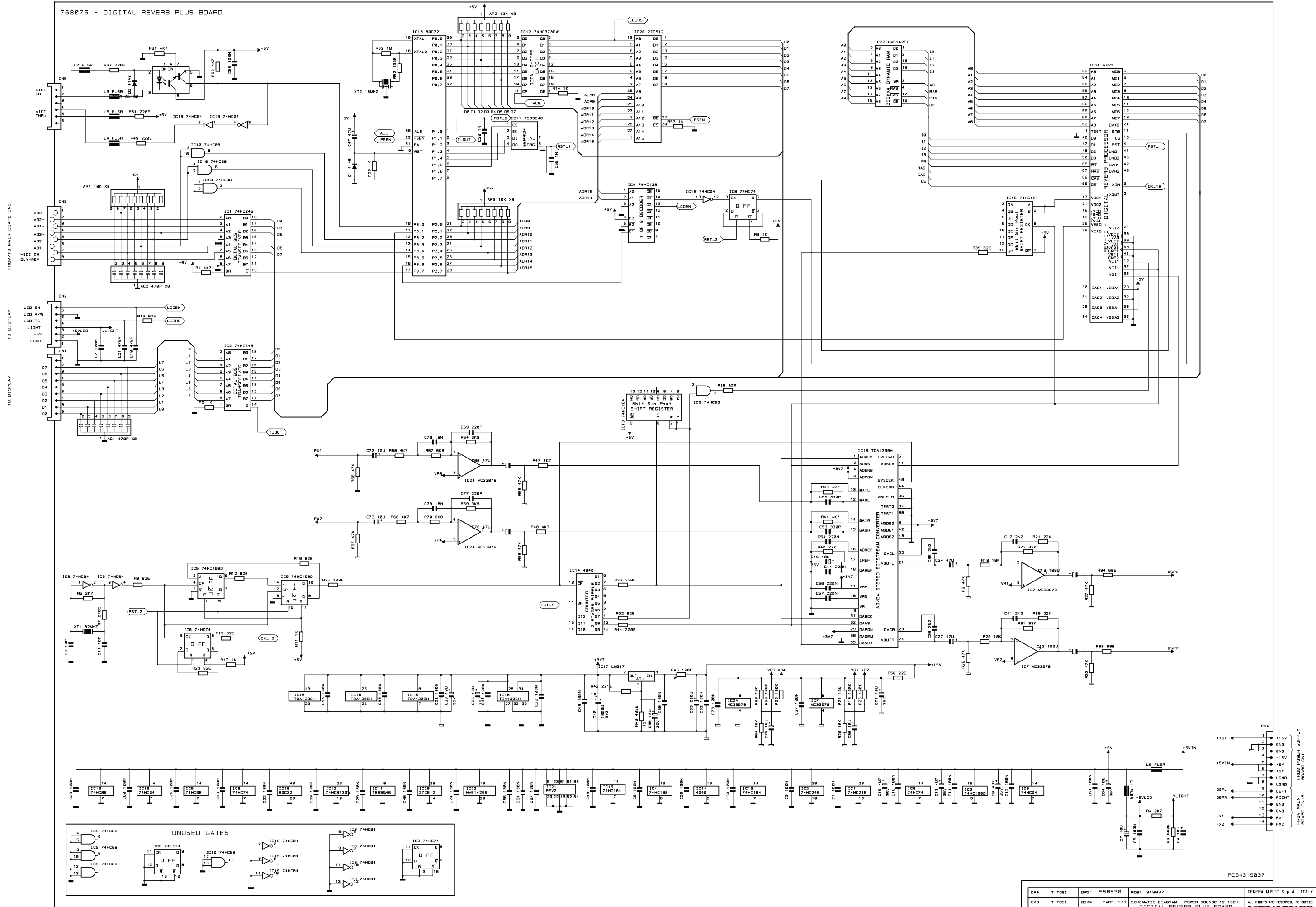

DRW	T. TOSI	DNDR	550530	PCBR	319037	GENERALMIC S.p.A. ITALY
CKD	T. TOSI	DSKB	PART: 1/1	SCHEMATIC DIAGRAM POWER-SOUND 12-INCH DIGITAL REVERB PLUS BOARD (III VERSION)		ALL RIGHTS ARE RESERVED. NO COPIES OR REPRODUCTIONS OF THIS DOCUMENT WITHOUT WRITTEN CONSENT BY GENERALMIC.
APP.	L. ALOZZI	REV.	28-06-96			

## SPARE PARTS LIST

Accessories	
277081	Owner's Manual
Various	
667560	Chassis (POWERCASE 16)
667577	Chassis (POWERCASE 12)
667418	Cover (POWERCASE 16)
667417	Cover (POWERCASE 12)
657213	Left side
657212	Right Side
347242	Handle (POWERCASE 16)
347241	Handle (POWERCASE 12)
347028	"System" foot
340435	Adhesive Foot
340186	Mains Cable Fixing
238060	Transformer 230V (POWERCASE 16) (EU)
238037	Transformer 117V (POWERCASE 16) (US)
238056	Transformer 230V (POWERCASE 12) (EU)
238057	Transformer 117V (POWERCASE 12) (US)
110614	Mains Socket
110278	Main Switch
110018	T6.3A Fuse 5x20mm (POWERCASE 16) (EU)
110027	T10A Fuse 6.3x32mm (POWERCASE 16) (US)
110003	T3.15A Fuse 5x20mm (POWERCASE 12) (EU)
110037	T6.3A Fuse 6.3x32mm (POWERCASE 12) (US)
130297	Mains Cord (Europe Version)

Mechanical Parts	
347256	Two-colored Switch Cup (Pantone 564)
347251	Two-colored Knob (Pantone 5493)
347250	Two-colored Knob (Pantone 5473)
347249	Two-colored Knob (Pantone 564)
347248	Two-colored Knob (Pantone 562)
347247	Two-colored Knob (Pantone 556)
177434	Inner Panel (POWERCASE 16)
177433	Inner Panel (POWERCASE 12)
177431	Jack Support
177252	Power Supply Board Fixing
140241	Red RCA Socket
140240	Black RCA Socket
140220	Jack Slim H F Apj678 Adimpex
667412	Front Panel (POWERCASE 16)
667411	Front Panel (POWERCASE 12)
657211	Display Cover
657210	LEDs Cover
347255	Two-colored Slider Knob (Pantone 5493)
347254	Two-colored Slider Knob (Pantone 5473)
347253	Two-colored Slider Knob (Pantone 564)
347252	Two-colored Slider Knob (Pantone 556)
080745	2x16 Characters Lcd Display

## Digital Reverb Board

758075 Digital Reverb Board (III Version) (PCB#319057)	
230569	* FL5R200PNT EMI Coil For Signal
141059	* Con V M 9 C Mini Mate Burndy
141058	* Con V M 6 C Mini Mate Burndy
141015	* Con V F 14c P=1.27 Mmatch Amp
141012	* Con V F 8 C P=1.27 Mmatch Amp
103021	* Tda1309hn2 Bitstream Ad/Da Con
103016	* 74hc373dw Octal D-Type Latch
103015	* 74hc164m 8bit S To P Shift Reg
103014	* 74hc109d Soic Dual J-/K F-F
103013	* 74HC138 1 OF 8 DECODER SMD
103010	* 74hc04d Soic Hex Inverter
103007	* 74hc74d Soic Dual Flip-Flop
103002	* 74hc245dw Soic Octal Bus Transceiver
103001	* 74hc08d Soic Quad 2-Input And Gate
100919	* Mc33078 Dual Ln J-Fet Operational Amplifier
100642	* Ts93c46 1Kbit Eeprom Memory
100628	* Rev2 Digital Reverb Processor
100617	* 74HC4040 12-Stage Binary Counter
100586	* HM514256P10 Dynamic Ram 1mbit Ta=100n
100579	* 80C32 Cpu Fc=16MHz
100066	* Lm317 1.2v-37v 1.5a Adj Reg
100035	* 6N138 Optocoupler
050492	* 10Kx8 1/8w 5% Resistor Array
042435	* 432E 1/4w 1% Metalized Film Resistor
042405	* 221E 1/4w 1% Metalized Film Resistor
010724	* 16MHz Ceramic Resonator With Capacitors
010718	* 32MHz Quartz Resonator
010660	* 470p 10% 50V X8 Cap Array
557023	Programed EPROM
100721	* 27C512 Eprom 512Kbit Ta=200ns

## Mains Filter Board

767987 Mains Filter Board (PCB#315016) (EU)	
768005 Mains Filter Board (Pcb#315016) (US)	
230565	* 2.5mH 250V 3A AC Line Filter
140010	* 3 Contacts P=10 Vert Terminal Block
110113	* Fuse Clip 5x20mm 6A max (EU)
110114	* Fuse Clip 6.3x32mm 10A Max (US)
020493	* 100n 250Vac MKP EMI Capacitor
010719	* 2n2 250V 7A 20% AC Line Capacitor

## 2x250W Power Amplifier Board

737063	2x250W Power Amplifier Board (EU)
737064	2x250W Power Amplifier Board (EU)
768067 * 2x250W Power Amplifier Board (PCB#317205)	
230557	** 1uh Hor Coil For Amplifier
141132	** Con V M 10c P=5.08 Pa253 Gibi
141065	** Con H M 12c Mini Mate Burndy
141056	** Con V M 3 C Mini Mate Burndy
141012	** Con V F 8 C P=1.27 Mmatch Amp
140350	** Con V M 3 C Msf Lumberg
110316	** Relay 24V / 1 Switch no 16A 250V
110119	** Fuse Clip 10A max (EU) (US)
110082	** T1A Fuse 6.3x32mm (US)
110026	** T1.25A Fuse 6.3x32mm (US)
110022	** T8A Fuse 6.3x32mm (US)
110021	** T5A Fuse 6.3x32mm (US)
100019	** TI071 Ln J-Fet Op Amp
090917	** MJE350 TO126 Pnp Transistor
090916	** MJE340 TO126 Npn Transistor
090201	** 2n5401 To92 Pnp Transistor
090200	** 2n5550 To92 Npn Transistor
090194	** BC560 TO92 LN Pnp Transistor
090183	** Bc550 To92 Ln Npn Transistor
080819	** Ptc 70 Pth59f04bg222ts
080607	** Kbp25 25a 200V Bridge Rec Dio
080606	** GBU8D 8A Rectifier Diodes Bridge
080342	** 30V 1w 5% Zener Diode
080293	** 15V 1w 5% Zener Diode
080282	** 13V 1w 5% Zener Diode
080261	** 10V1w 5% Zener Diode
080245	** 7V5 1w 5% Zener Diode
080171	** Fe6b 6a 100V Fast Recovery Diode
080168	** W02M 1.5A Rectifier Diodes Bridge
080156	** 1N4002 1A 100V Rectifier Diode
080103	** 1N4148 100mA 75V Signal Diode
727421	** Fan Group
110359	*** Dc Fan 24v 80x25
177586	** Jack Socket Support
177248	** Tunnel Closer
120819	** Fan Spacer
110023	** T8A Fuse 5x20mm (EU)
110020	** T5A Fuse 5x20mm (EU)
110013	** T1.25A Fuse 5x20mm (EU)
110011	** T1A Fuse 5x20mm (EU)
100132	** 7824 +24V 1A Voltage Regulator
100060	** 7815 +15v 1a Voltage Regulator
100059	** 7805 +5v 1a Voltage Regulator
100049	** 7915 -15v 1a Voltage Regulator
090920	** Mje803 To126 Npn Darl Transistor
090919	** Mje15031 To220 Pnp Transistor
090918	** MJE15030 TO220 Npn Transistor
090913	** MJE4352 TO218 Pnp Transistor
090912	** MJE4342 TO218 Npn Transistor
090863	** TIP36C TO218 Pnp Transistor
090862	** TIP35C TO218 Npn Transistor

## 2x150W Power Amplifier Board

767998 2x150W Power Amplifier Board (PCB#317183) (EU)	
768001 2x150W Power Amplifier Board (PCB#317183) (US)	
141130	* Con H M 8c P=5.08 Pa253 Gibi
141065	* Con H M 12c Mini Mate Burndy
141061	* Con H M 3 C Mini Mate Burndy
141012	* Con V F 8 C P=1.27 Mmatch Amp
140226	* Jack Mono Asme An
110307	* Relay 24V / 2 Switch 5A 250V
110113	* Fuse Clip 5x20mm 6A max (EU)
110114	* Fuse Clip 6.3x32mm 10A Max (US)
100941	* STK4241V 2x120w Hybrid Amplifi
100084	* TL074 Quad J-Fet Operational Amplifier
090917	* MJE350 TO126 Pnp Transistor
090201	* 2n5401 To92 Pnp Transistor
090200	* 2n5550 To92 Npn Transistor
090192	* BC307 TO92 Pnp Transistor
090182	* BC173C TO92 Npn Transistor
090153	* BC327 TO92 Pnp Transistor

080605	* KBL02 4A 200V Bridge Rectifier Diode
080342	* 30V 1w 5% Zener Diode
080293	* 15V 1w 5% Zener Diode
080282	* 13V 1w 5% Zener Diode
080168	* W02M 1.5A Rectifier Diodes Bridge
080156	* 1N4002 1A 100V Rectifier Diode
080103	* 1N4148 100mA 75V Signal Diode
042555	* 4K22 1/4w 1% Metalized Film Resistor
110358	Dc Fan 24v 60x25
110018	T6.3A Fuse 5x20mm (EU)
110013	T1.25A Fuse 5x20mm (EU)
110011	T1A Fuse 5x20mm (EU)
110082	T1A Fuse 6.3x32mm (US)
110037	T6.3A Fuse 6.3x32mm (US)
110026	T1.25A Fuse 6.3x32mm (US)
100132	7824 +24V 1A Voltage Regulator
100060	7815 +15V 1A Voltage Regulator
100059	7805 +5V 1A Voltage Regulator
100049	7915 -15v 1a Voltage Regulator
080819	Ptc 70 Pth59f04bg222ts

## Main Board

768004 Main Board (PCB#319039) (POWERCASE 16)	
768003 Main Board (PCB#319038) (POWERCASE 12)	
347020	* 15 LEDs Support
340771	* Led Spacer H=16,3mm
141065	* Con H M 12c Mini Mate Burndy
141061	* Con H M 3 C Mini Mate Burndy
141056	* Con V M 3 C Mini Mate Burndy
141015	* Con V F 14c P=1.27 Mmatch Amp
141012	* Con V F 8 C P=1.27 Mmatch Amp
141011	* Con V F 6 C P=1.27 Mmatch Amp
141010	* Con. Vert. Female 4 Contacts P=1.27 Match Amp.
140397	* 2sw 2pos V Slider Switch
140231	* Jack H F Socket S-G4617 Smk
140220	* Jack Slim H F Apj678 Adimpex
110258	* Encoder
102006	* Hybrid St Graphic Equalizer
102005	* Hybrid 3 Band Tone Control
102004	* Hybrid Master & Bal Output
102002	* Hybrid Balanced Input Circuit
102001	* Hybrid Stereo Headphones Amp
100927	* Lb1412 12 Dots Level Meter
100919	* Mc33078 Dual Ln J-Fet Operational Amplifier
100918	* Mc33178 Dual Op Amp
100620	* 74hc86 Quad 2-Input Exor Gate
100614	* 74HC74 Dual Flip-Flop
090183	* Bc550 To92 Ln Npn Transistor
080733	* Led 2.5x5mm Rect Diff Green
080731	* Led 2.5x5mm Rect Diff Red
080706	* Led 3mm 60deg Diffused Green
080705	* Led 3mm 60deg Diffused Red
075802	* 2x50Ka 14mm Vert. Rotary Pot
075699	* 50Ka 9mm Vert. Rotary Pot
075615	* 2x10Kc 14mm Vert. Rotary Pot
075591	* 10Kc 9mm Vert. Rotary Pot
074761	* 2x50Kb C.C. 14mm Vert. Rotary
074753	* 2x50Kw C.C. 14mm Vert. Rotary
074698	* 50Kw C.C. 9mm Vert. Rotary Pot
073596	* 2x10Ka 60mm Slider Pot Slim
073574	* 10Ka 60mm Slider Pot Slim
072705	* 2x50K W 30mm Slider Potentiometer
042537	* 3K01 1/4w 1% Metalized Film Resistor

## Master Outputs Board

767966 Master Outputs Board (PCB#317162)	
141011	* Con V F 6 C P=1.27 Mmatch Amp
141010	* Con. Vert. Female 4 Contacts P=1.27 Match Amp.
140231	* Jack H F Socket S-G4617 Smk
140220	* Jack Slim H F Apj678 Adimpex

## 8 XLR Inputs Board

767964 8 XLR Inputs Board (PCB#317160)	
141183	* Xlr H F Norit Nc3fprho Neutrik
141061	* Con H M 3 C Mini Mate Burndy
141056	* Con V M 3 C Mini Mate Burndy
080705	* Led 3mm 60deg Diffused Red

## 4 XLR Inputs Board

767963 4 XLR Inputs Board (PCT#317171)	
141183	* Xlr H F Norit Nc3fprho Neutrik
141061	* Con H M 3 C Mini Mate Burndy
141056	* Con V M 3 C Mini Mate Burndy
080705	* Led 3mm 60deg Diffused Red

## Notes:

Each spare part is single quantity unless otherwise specified

Asterisk prefix explanation:

Omitted = First level spare part.

One asterisk = Second level, part of previous listed first level part.

Two asterisk = Third level, part of previous listed second level part.

Three asterisk = .....

Any request for not above mentioned part must encompass specific description including:

- 1) Model name,
- 2) Section,
- 3) Module code,
- 4) Reference name,
- 5) Quantity number.