

Car Audio
Service Manual

GoldMaster

DVD-5060 USB

www.goldmaster.com.tr

SET BLOCK DIAGRAM

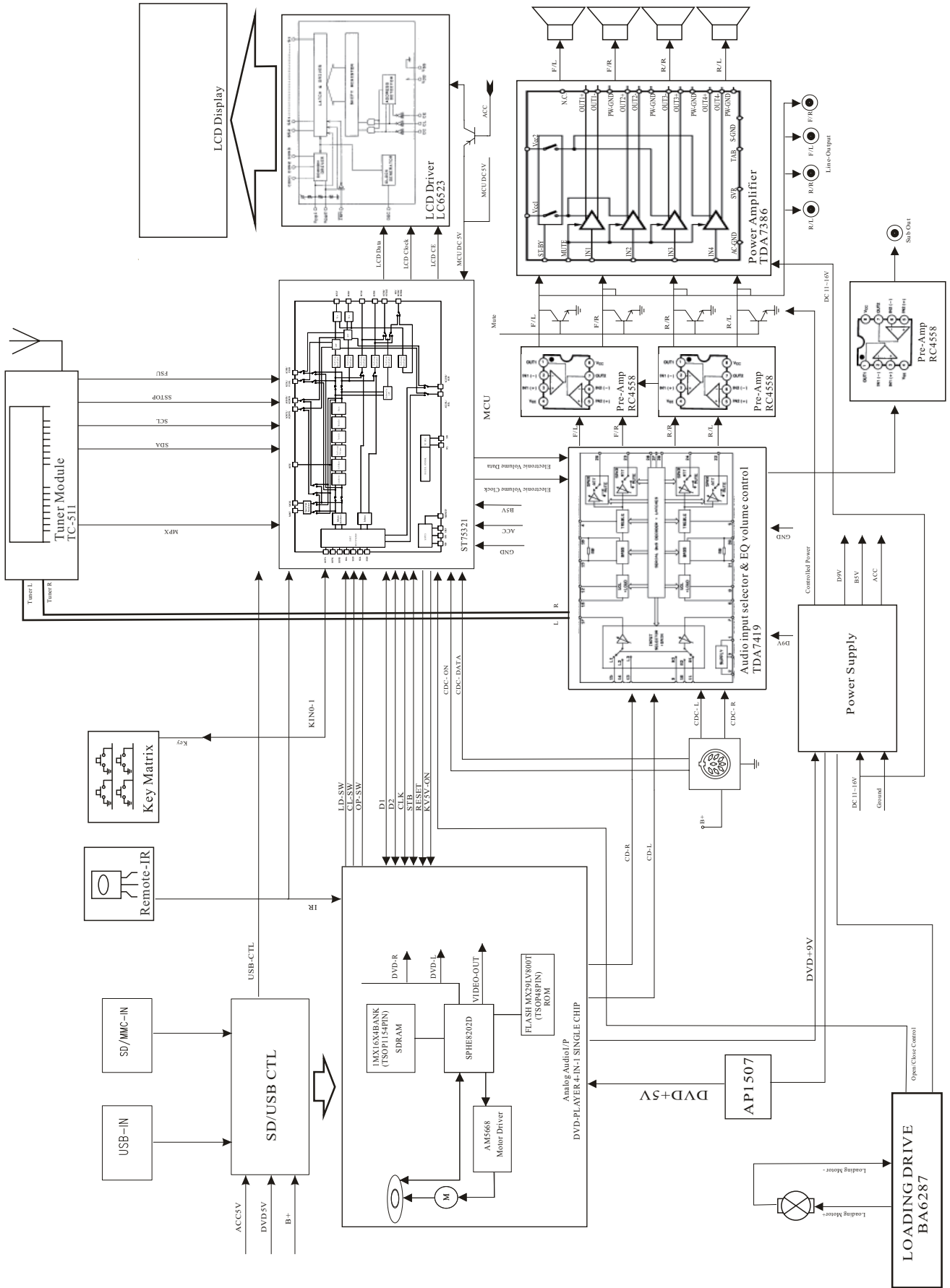

SET WIRING DIAGRAM

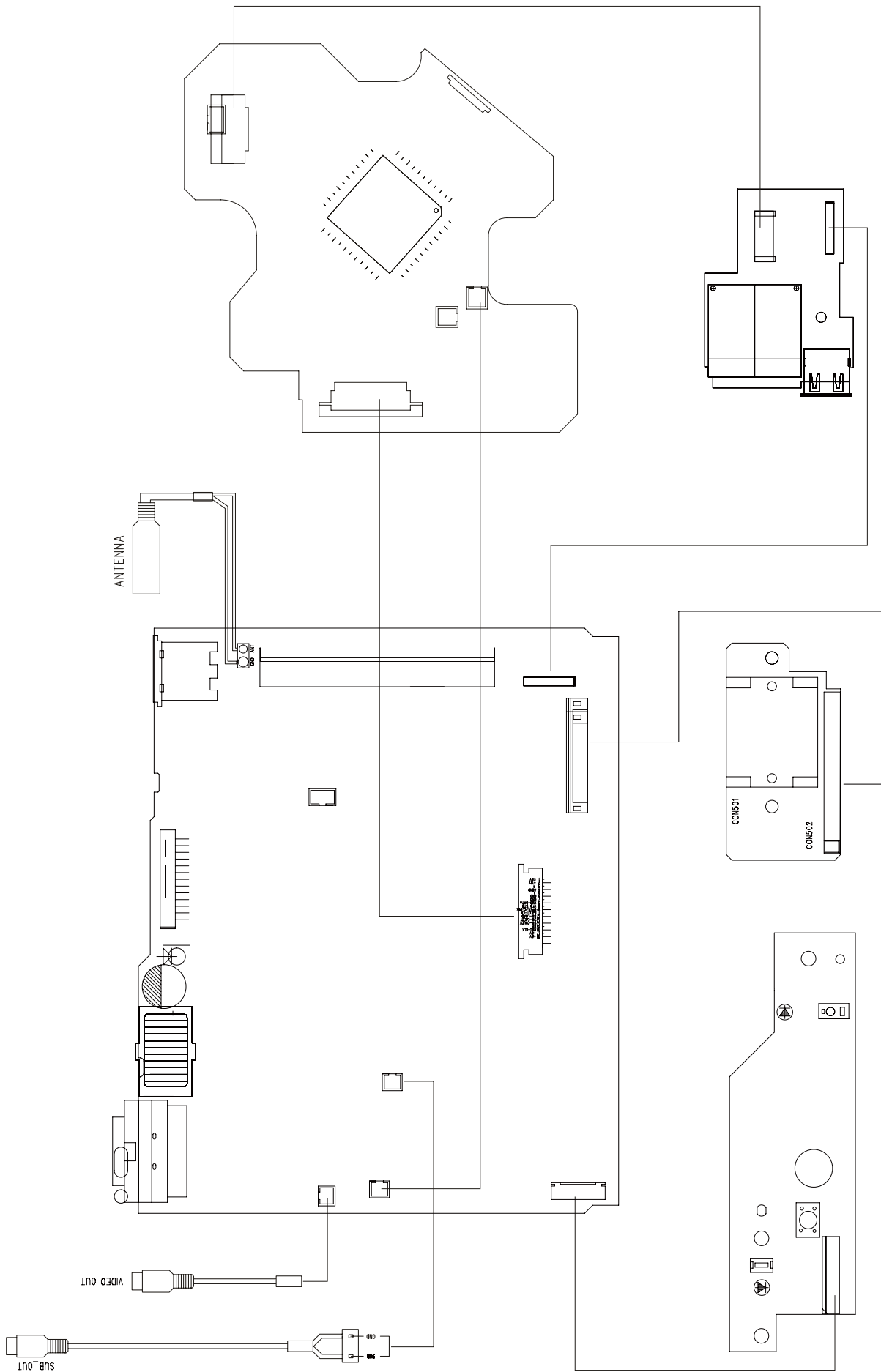

FRONT BOARD - CIRCUIT DIAGRAM

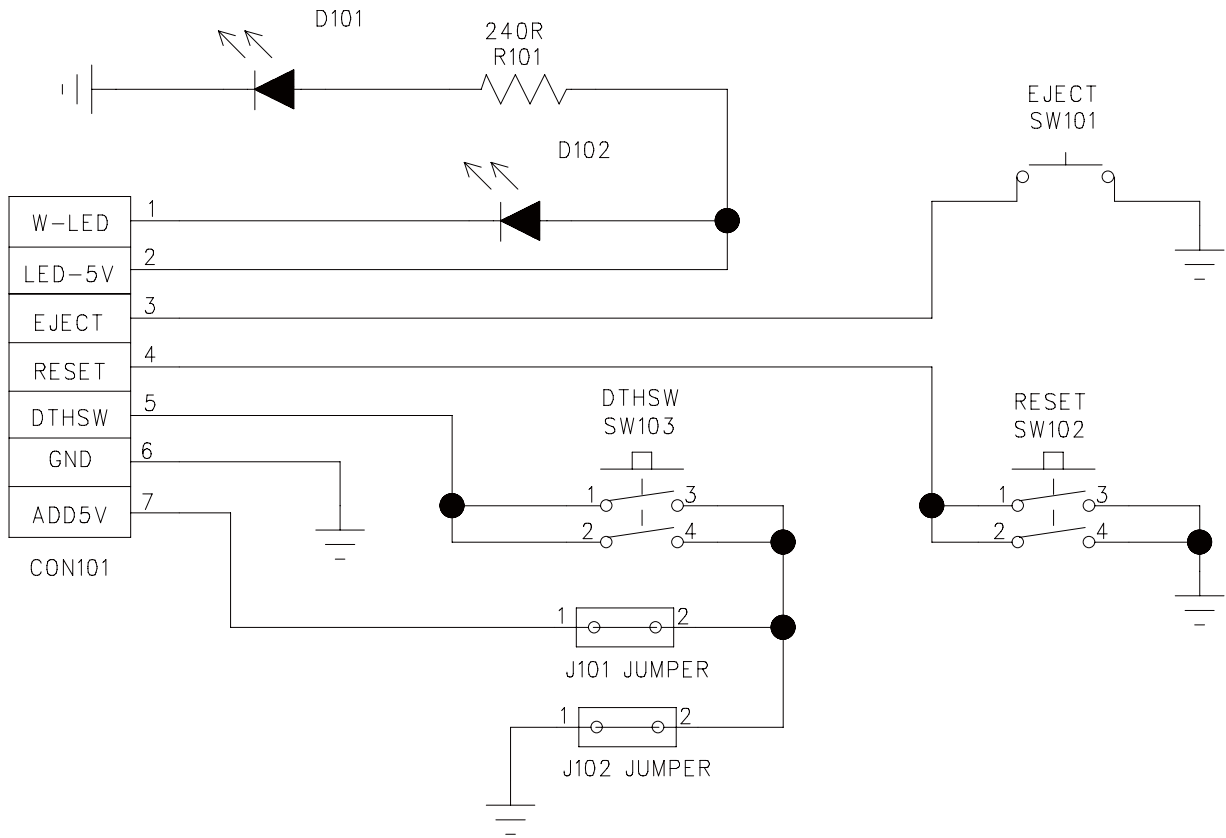

FRONT BOARD - LAYOUT DIAGRAM

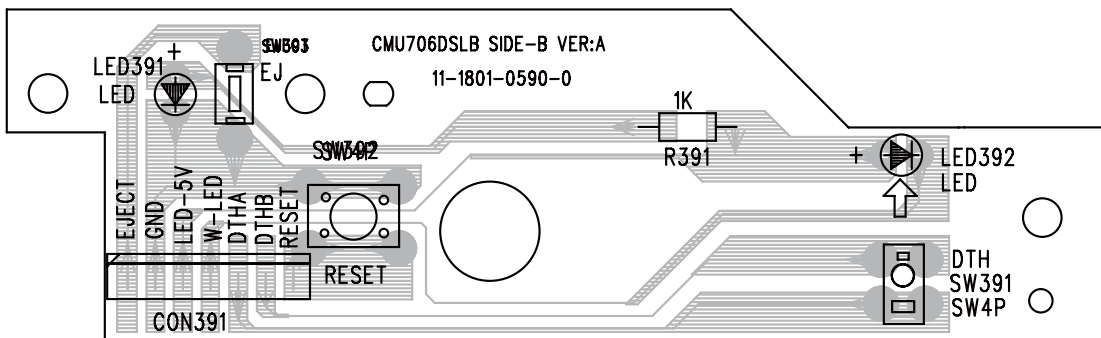

CONNECTOR BOARD - CIRCUIT DIAGRAM

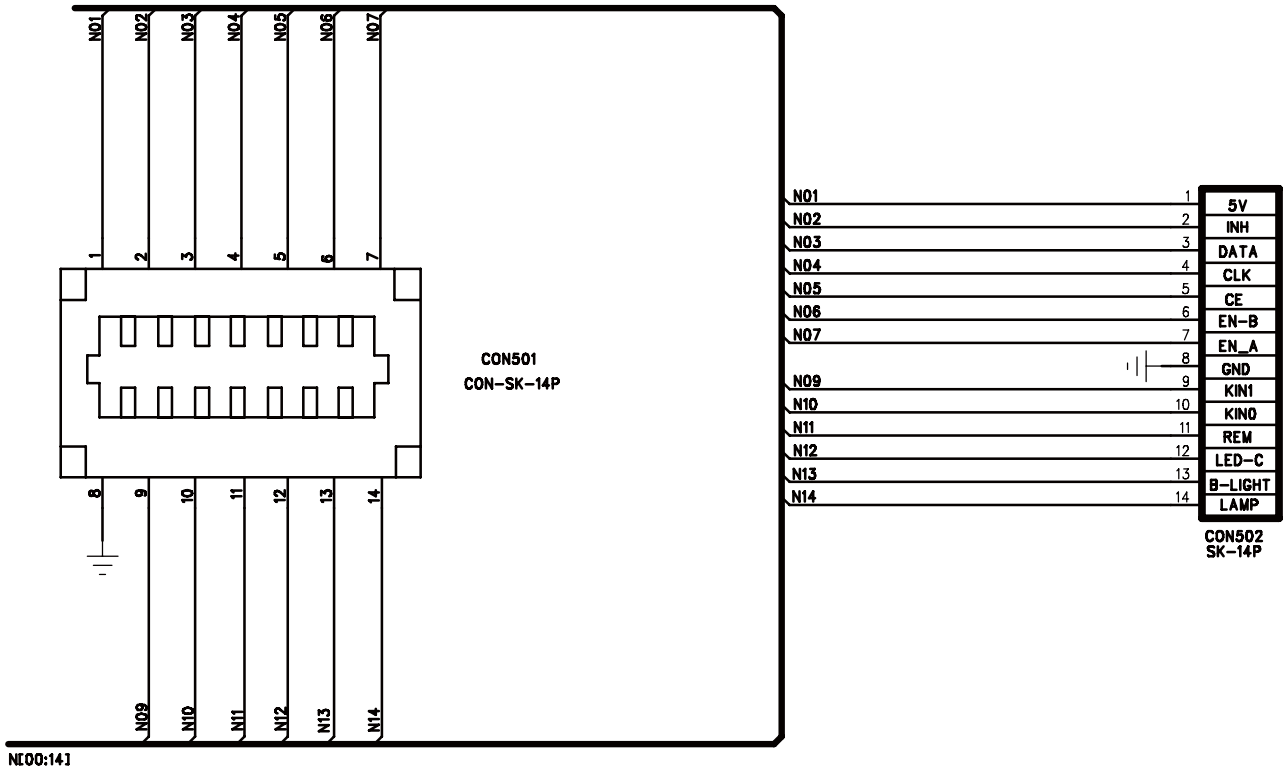

CONNECTOR BOARD - LAYOUT DIAGRAM

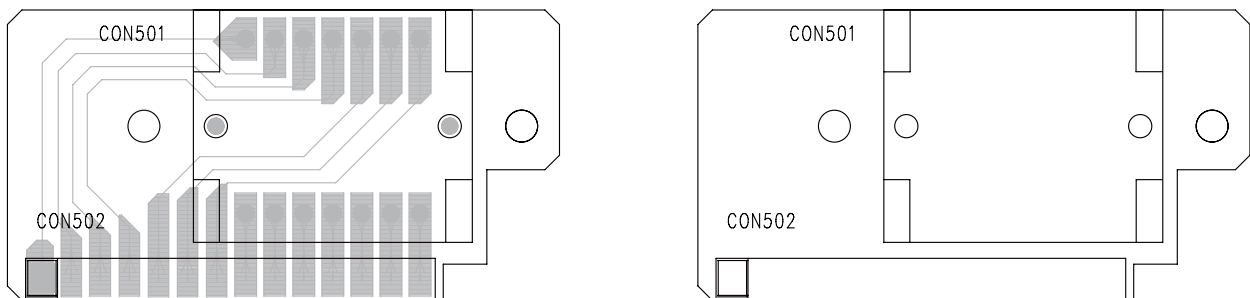

MAIN BOARD - CIRCUIT DIAGRAM

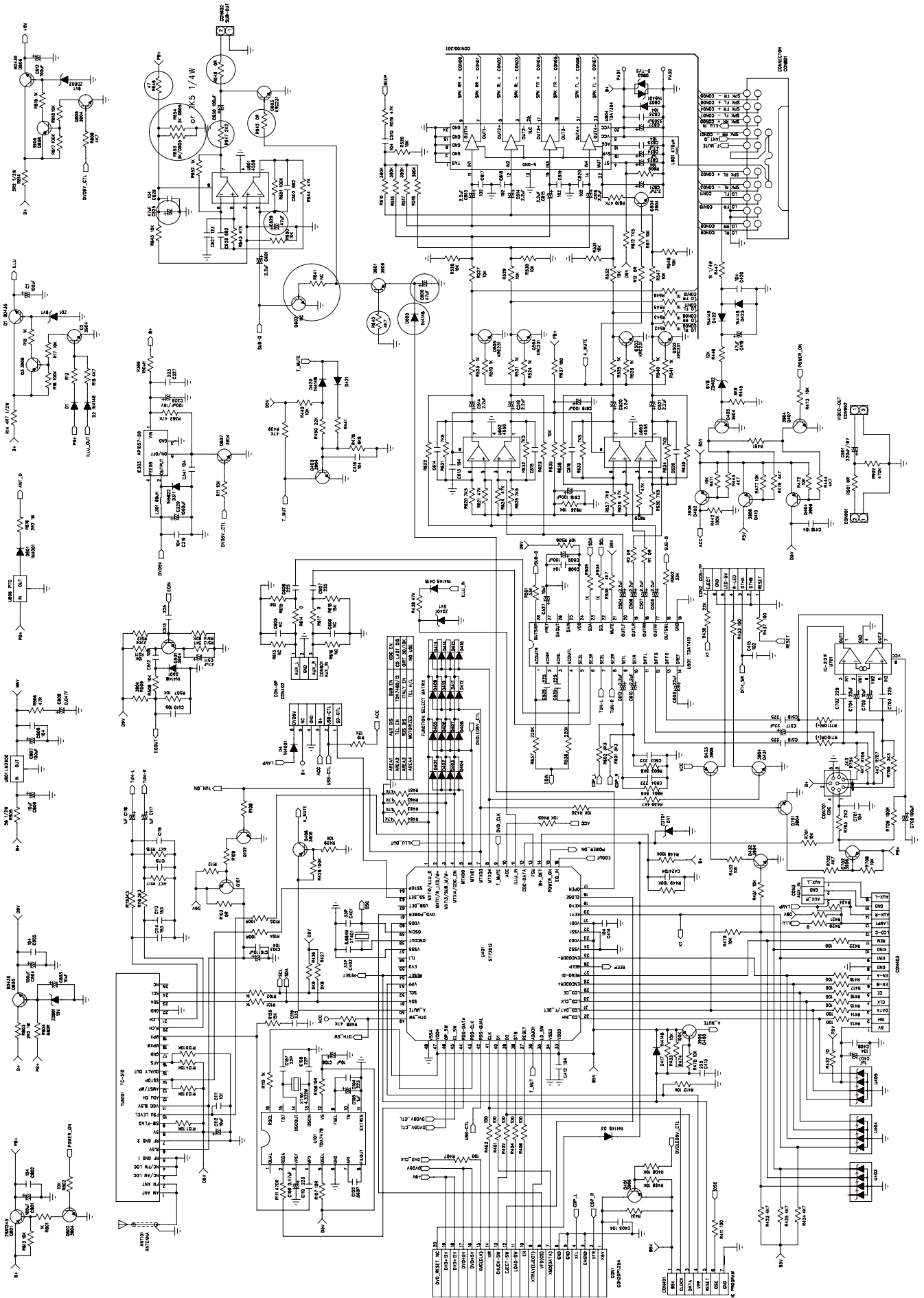

MAIN BOARD - PCB LAYOUT BOTTOM VIEW

P/N:12(4)3000010162
FORYOU GENERAL
DATE:2006-07-14
DVU719E MB SIDE-A 1.6MM VER.A

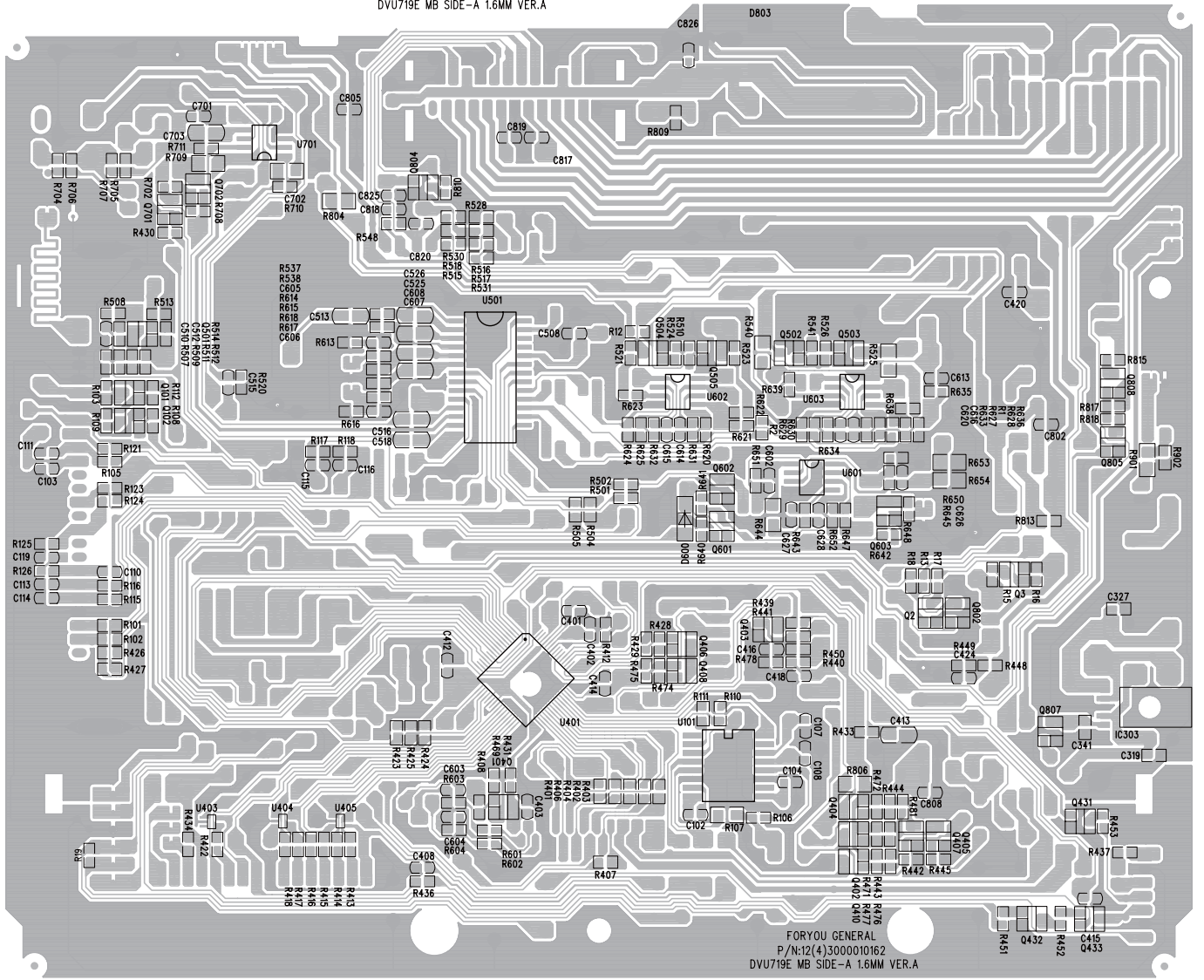

SD BOARD - CIRCUIT DIAGRAM

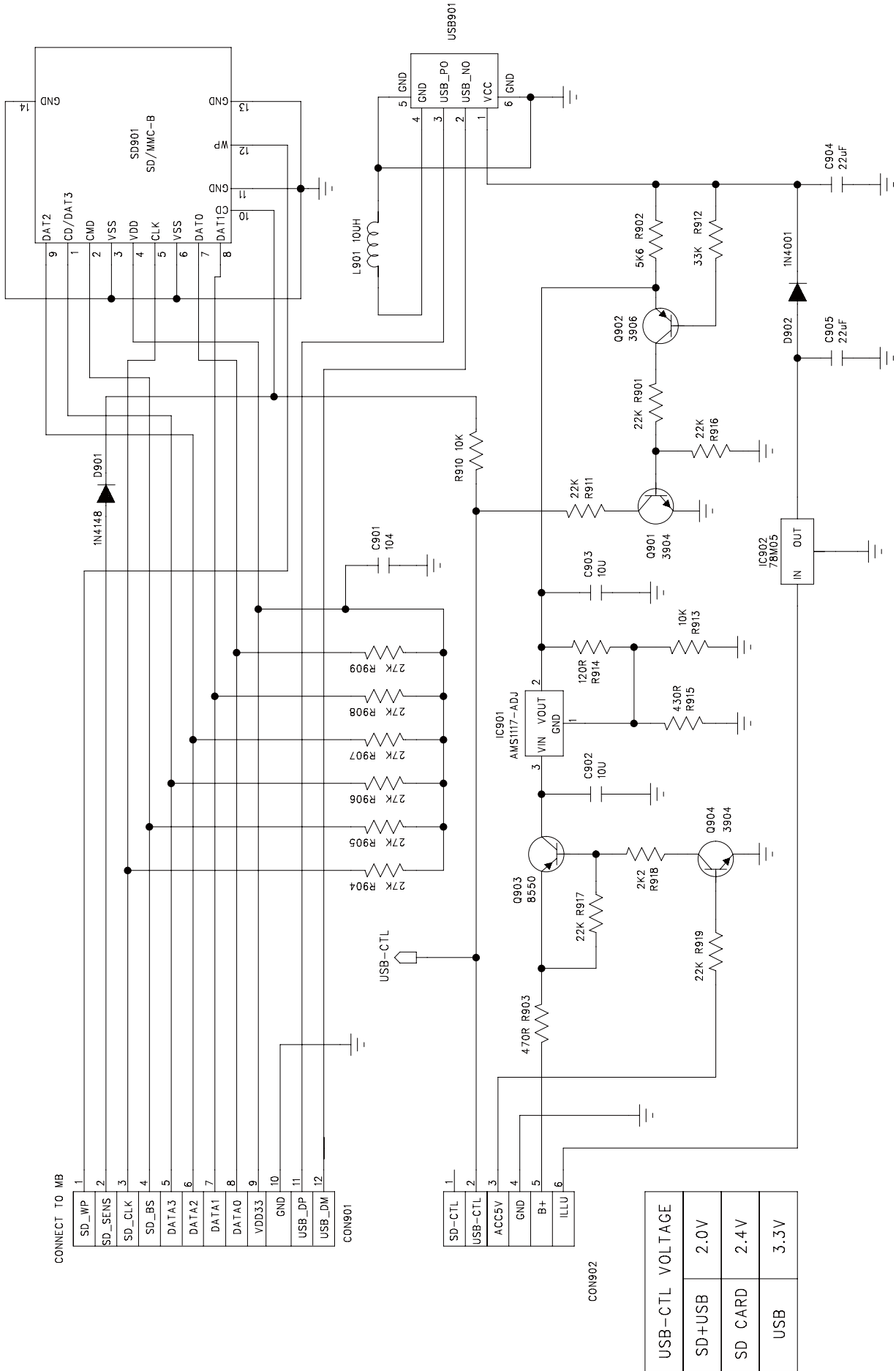

SD BOARD - LAYOUT DIAGRAM TOP VIEW

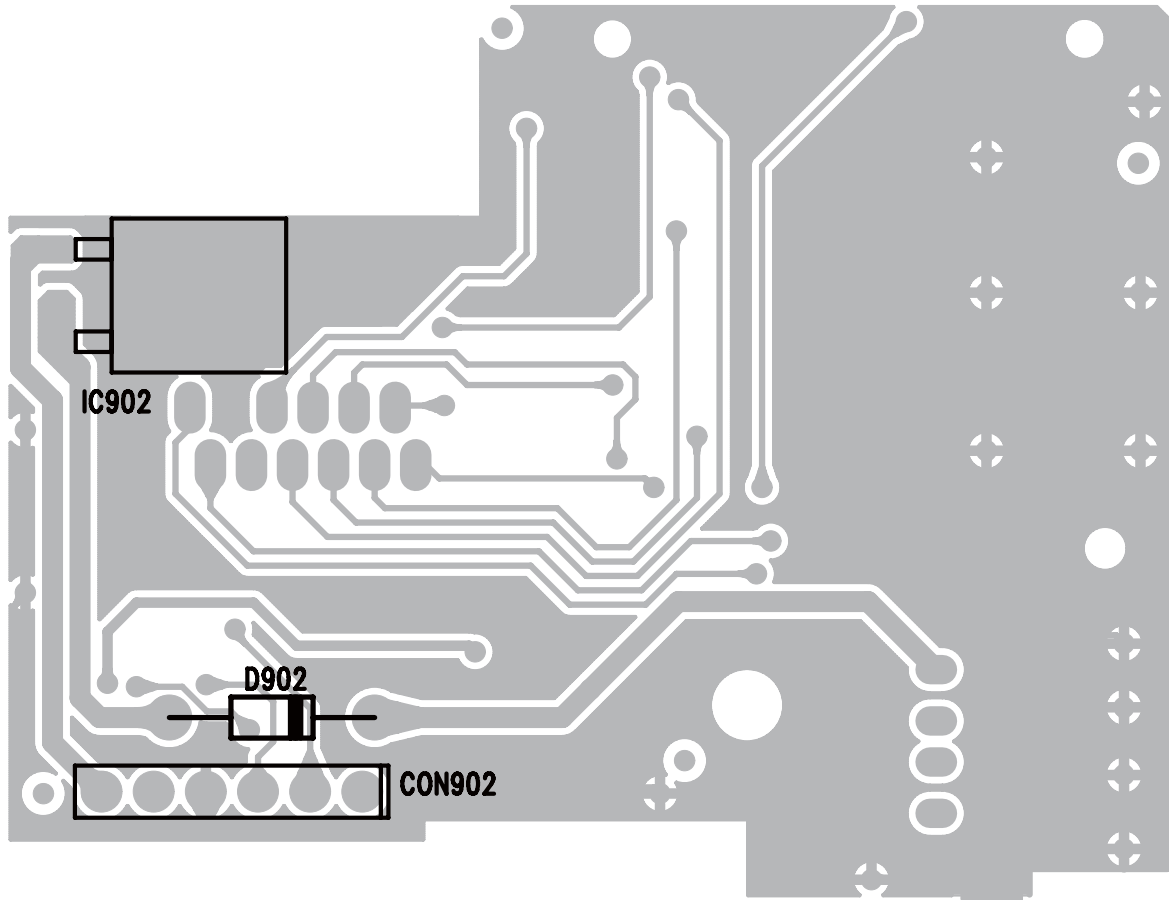

SD BOARD - LAYOUT DIAGRAM BOTTOM VIEW

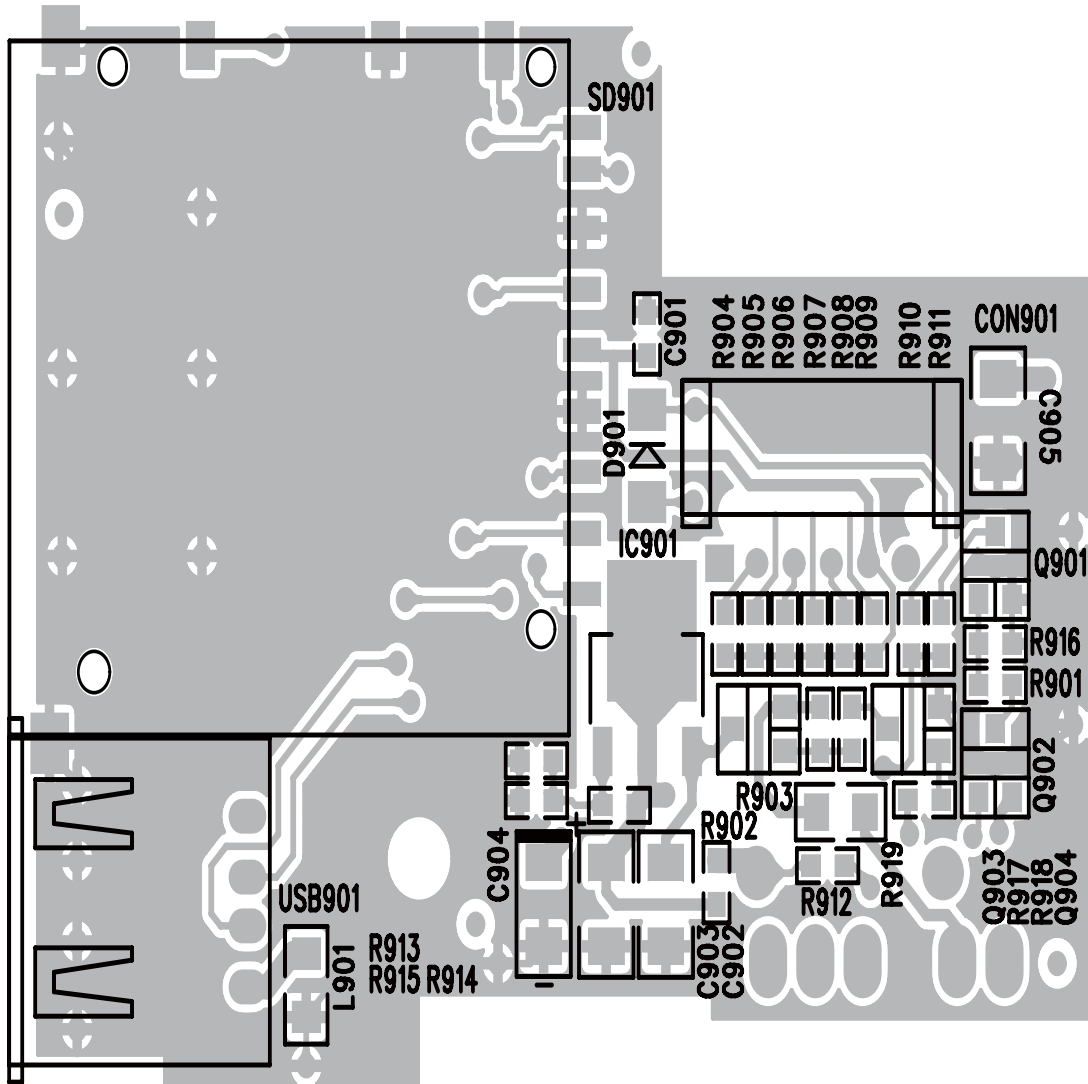

SERVO BOARD - CIRCUIT DIAGRAM

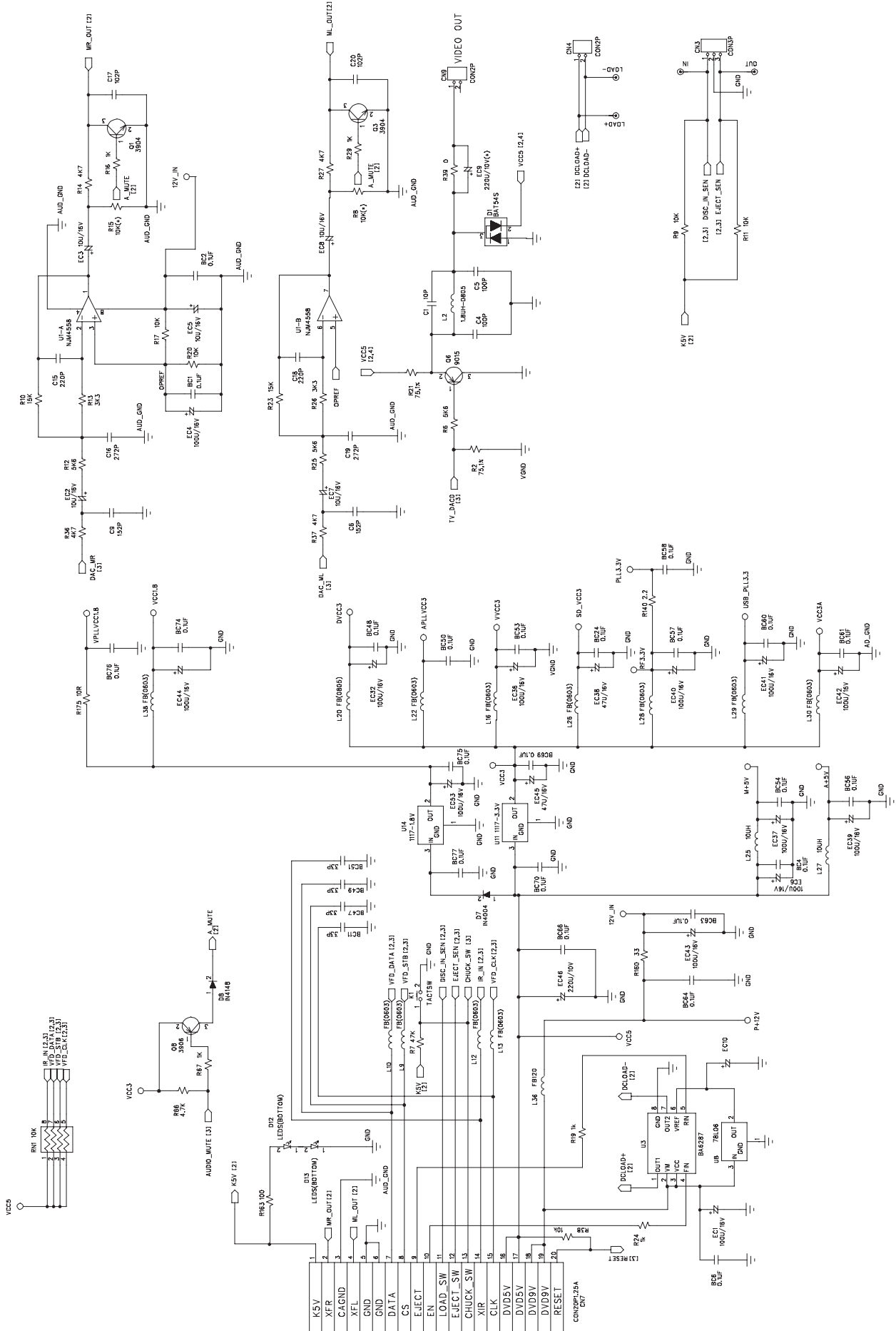

SERVO BOARD - CIRCUIT DIAGRAM

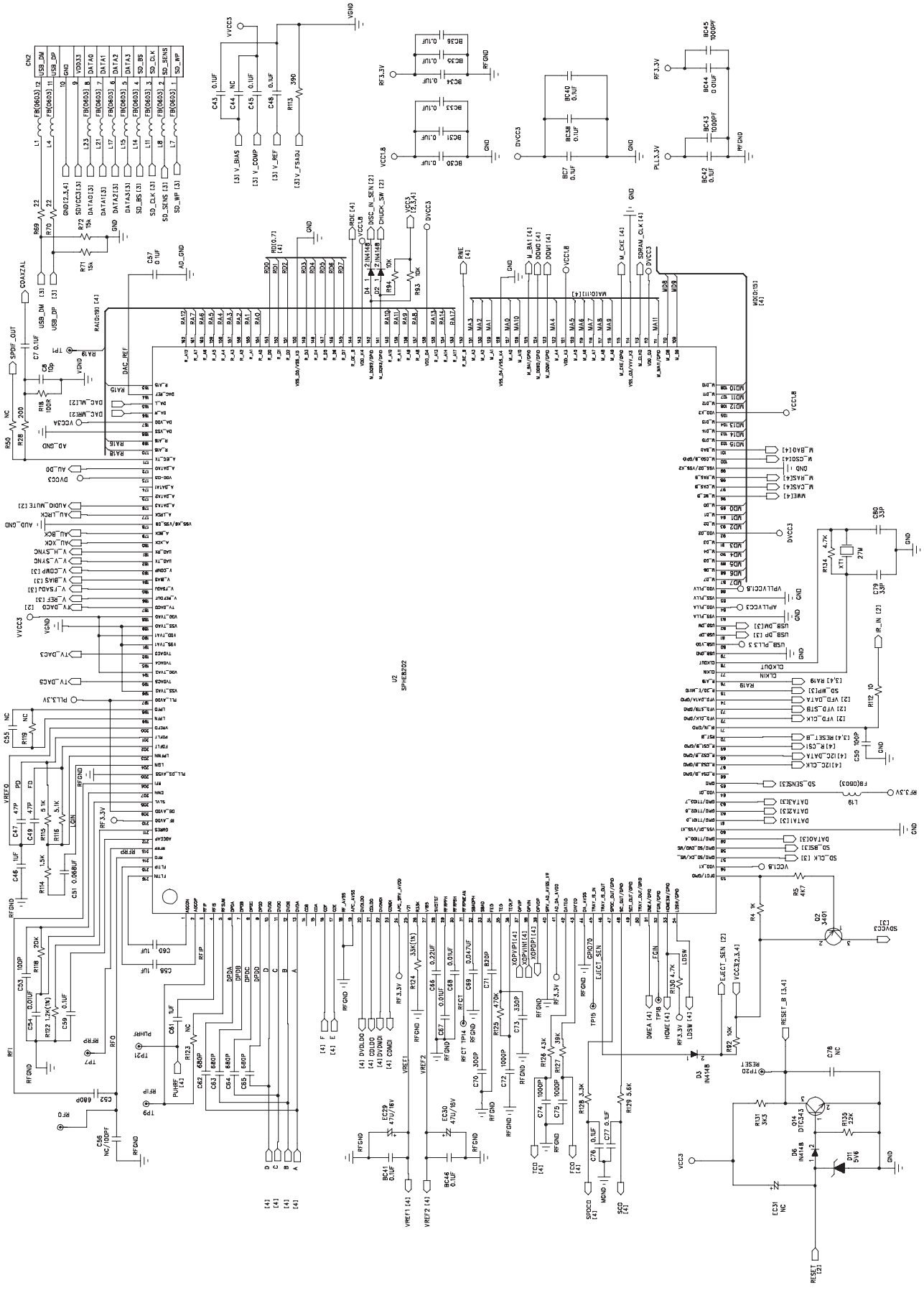

SERVO BOARD - LAYOUT DIAGRAM TOP VIEW

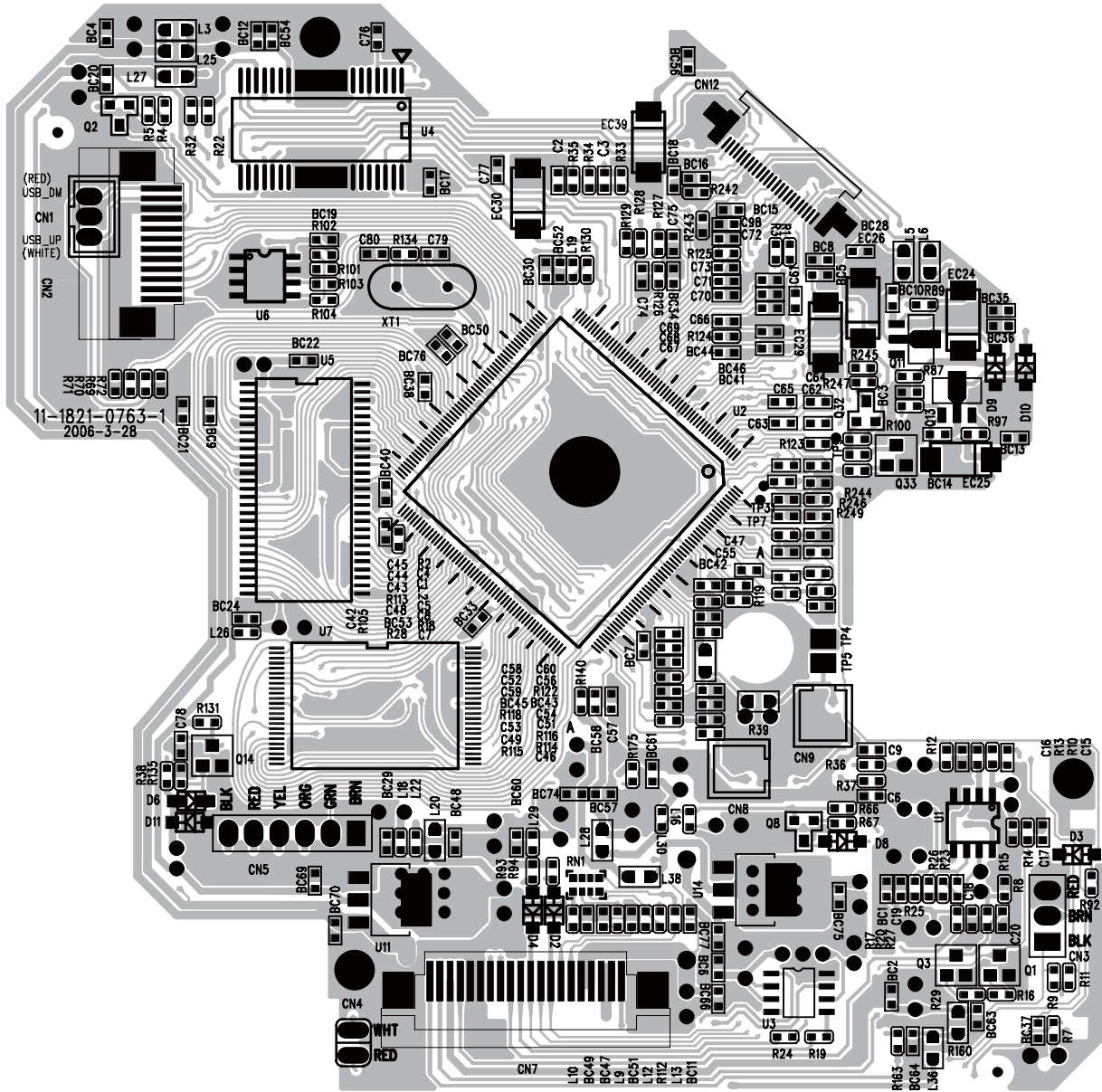

SERVO BOARD - LAYOUT DIAGRAM BOTTOM VIEW

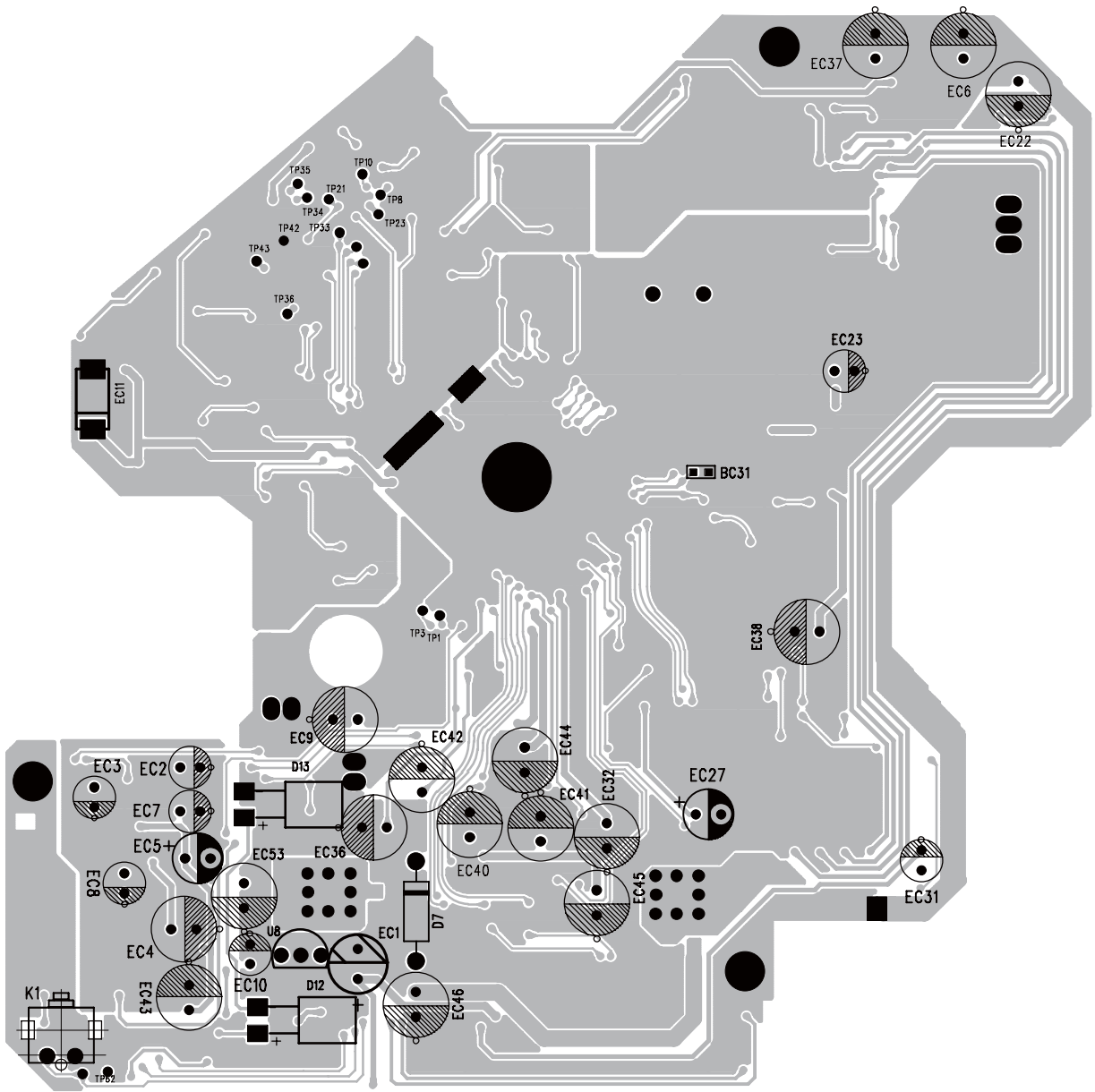

KB BOARD - CIRCUIT DIAGRAM

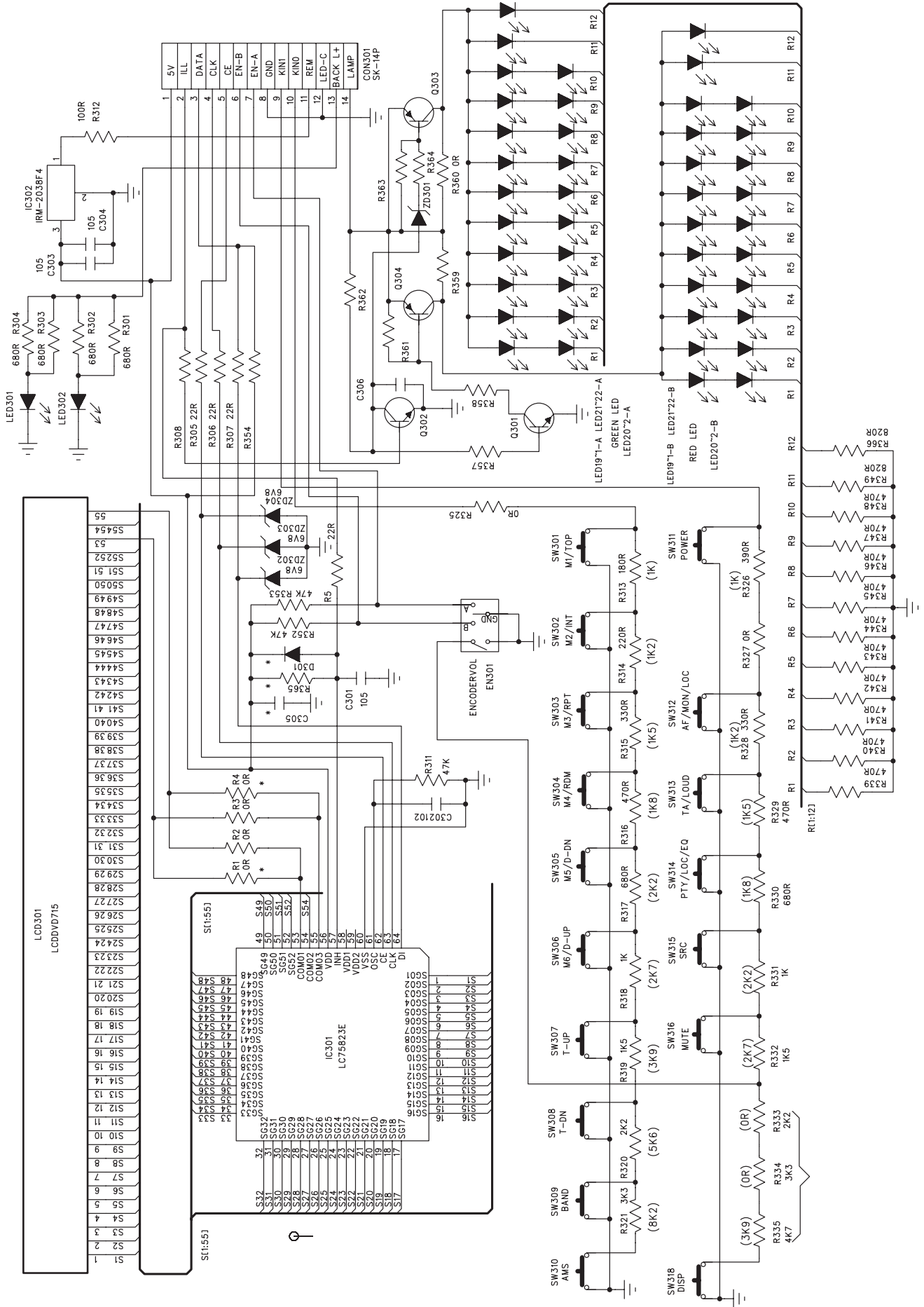

KB BOARD - CLAYOUT DIAGRAM TOP VIEW

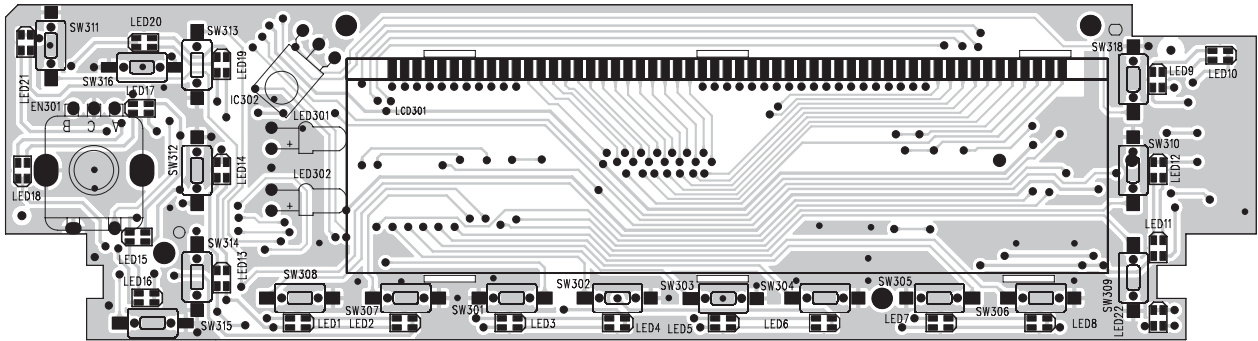

KB BOARD - CLAYOUT DIAGRAM BOTTOM VIEW

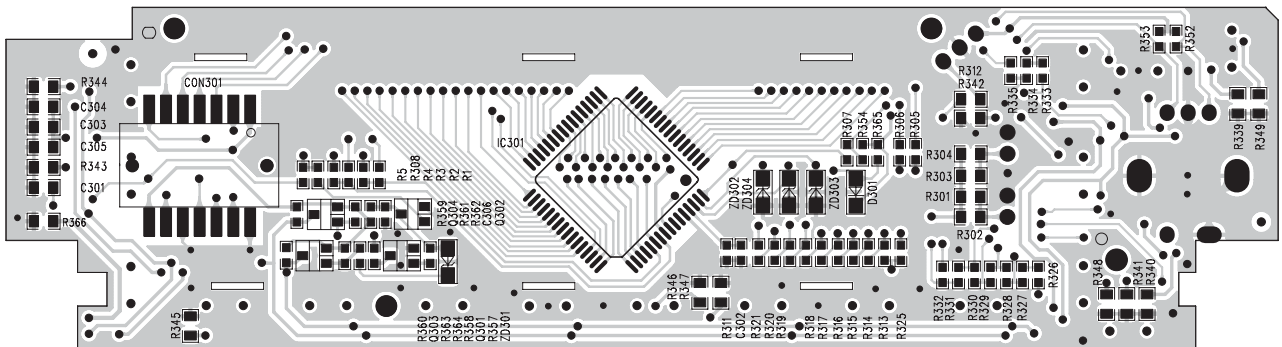

EXPLODED VIEW - MAIN NUIT

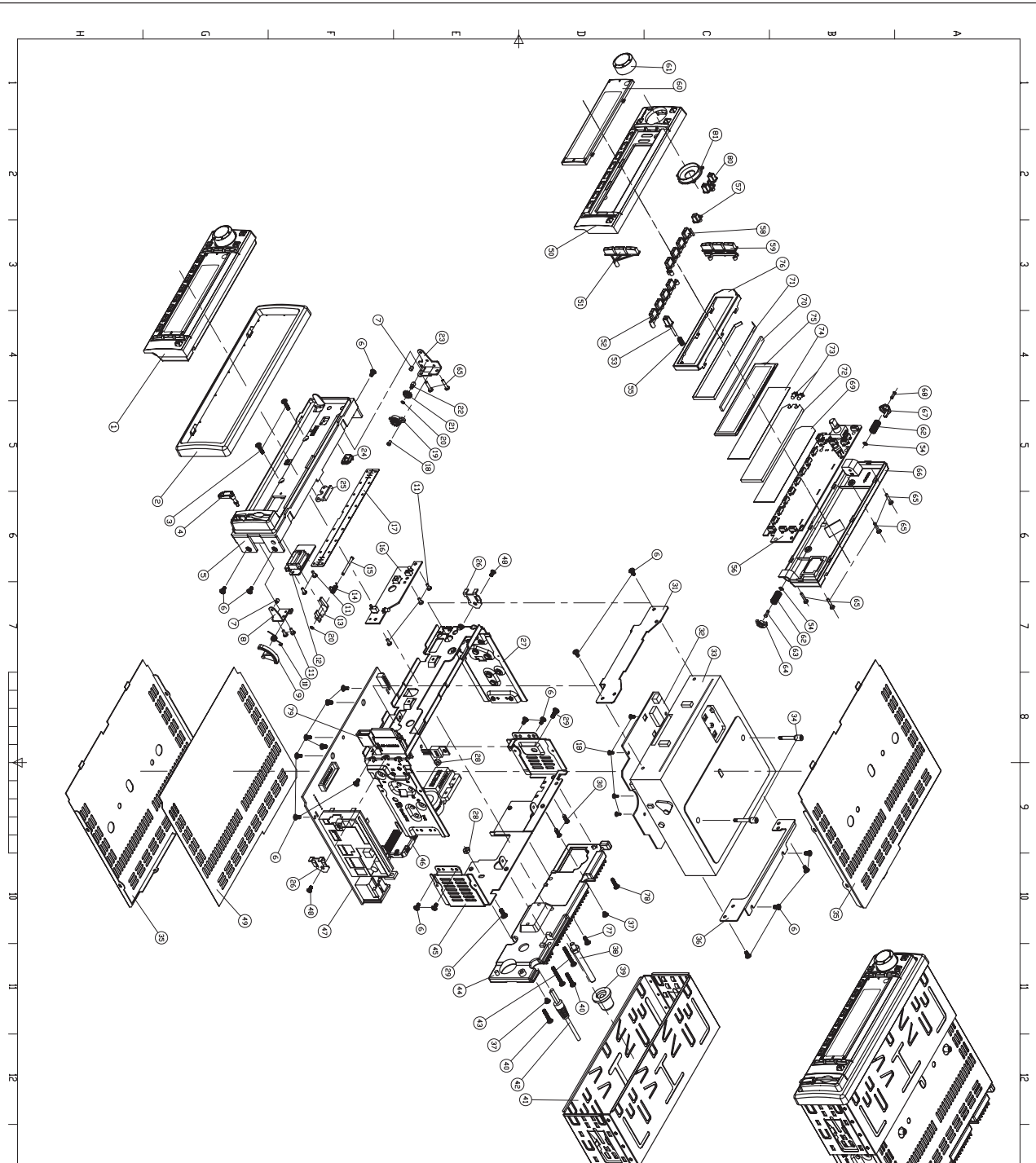

Part No.	Description	Qty	Unit
81	CHASSIS (MAIN UNIT)	1	PCB
82	FRONT PANEL	1	PCB
83	REAR PANEL	1	PCB
84	TOP COVER	1	PCB
85	BOTTOM COVER	1	PCB
86	FRONT PANEL (L)	1	PCB
87	FRONT PANEL (R)	1	PCB
88	REAR PANEL (L)	1	PCB
89	REAR PANEL (R)	1	PCB
90	TOP COVER (L)	1	PCB
91	TOP COVER (R)	1	PCB
92	BOTTOM COVER (L)	1	PCB
93	BOTTOM COVER (R)	1	PCB
94	FRONT PANEL (L) (L)	1	PCB
95	FRONT PANEL (L) (R)	1	PCB
96	FRONT PANEL (R) (L)	1	PCB
97	FRONT PANEL (R) (R)	1	PCB
98	REAR PANEL (L) (L)	1	PCB
99	REAR PANEL (L) (R)	1	PCB
100	REAR PANEL (R) (L)	1	PCB
101	REAR PANEL (R) (R)	1	PCB
102	TOP COVER (L) (L)	1	PCB
103	TOP COVER (L) (R)	1	PCB
104	TOP COVER (R) (L)	1	PCB
105	TOP COVER (R) (R)	1	PCB
106	BOTTOM COVER (L) (L)	1	PCB
107	BOTTOM COVER (L) (R)	1	PCB
108	BOTTOM COVER (R) (L)	1	PCB
109	BOTTOM COVER (R) (R)	1	PCB
110	FRONT PANEL (L) (L) (L)	1	PCB
111	FRONT PANEL (L) (L) (R)	1	PCB
112	FRONT PANEL (L) (R) (L)	1	PCB
113	FRONT PANEL (L) (R) (R)	1	PCB
114	FRONT PANEL (R) (L) (L)	1	PCB
115	FRONT PANEL (R) (L) (R)	1	PCB
116	FRONT PANEL (R) (R) (L)	1	PCB
117	FRONT PANEL (R) (R) (R)	1	PCB
118	REAR PANEL (L) (L) (L)	1	PCB
119	REAR PANEL (L) (L) (R)	1	PCB
120	REAR PANEL (L) (R) (L)	1	PCB
121	REAR PANEL (L) (R) (R)	1	PCB
122	REAR PANEL (R) (L) (L)	1	PCB
123	REAR PANEL (R) (L) (R)	1	PCB
124	REAR PANEL (R) (R) (L)	1	PCB
125	REAR PANEL (R) (R) (R)	1	PCB
126	TOP COVER (L) (L) (L)	1	PCB
127	TOP COVER (L) (L) (R)	1	PCB
128	TOP COVER (L) (R) (L)	1	PCB
129	TOP COVER (L) (R) (R)	1	PCB
130	TOP COVER (R) (L) (L)	1	PCB
131	TOP COVER (R) (L) (R)	1	PCB
132	TOP COVER (R) (R) (L)	1	PCB
133	TOP COVER (R) (R) (R)	1	PCB
134	BOTTOM COVER (L) (L) (L)	1	PCB
135	BOTTOM COVER (L) (L) (R)	1	PCB
136	BOTTOM COVER (L) (R) (L)	1	PCB
137	BOTTOM COVER (L) (R) (R)	1	PCB
138	BOTTOM COVER (R) (L) (L)	1	PCB
139	BOTTOM COVER (R) (L) (R)	1	PCB
140	BOTTOM COVER (R) (R) (L)	1	PCB
141	BOTTOM COVER (R) (R) (R)	1	PCB
142	FRONT PANEL (L) (L) (L) (L)	1	PCB
143	FRONT PANEL (L) (L) (L) (R)	1	PCB
144	FRONT PANEL (L) (L) (R) (L)	1	PCB
145	FRONT PANEL (L) (L) (R) (R)	1	PCB
146	FRONT PANEL (L) (R) (L) (L)	1	PCB
147	FRONT PANEL (L) (R) (L) (R)	1	PCB
148	FRONT PANEL (L) (R) (R) (L)	1	PCB
149	FRONT PANEL (L) (R) (R) (R)	1	PCB
150	FRONT PANEL (R) (L) (L) (L)	1	PCB
151	FRONT PANEL (R) (L) (L) (R)	1	PCB
152	FRONT PANEL (R) (L) (R) (L)	1	PCB
153	FRONT PANEL (R) (L) (R) (R)	1	PCB
154	FRONT PANEL (R) (R) (L) (L)	1	PCB
155	FRONT PANEL (R) (R) (L) (R)	1	PCB
156	FRONT PANEL (R) (R) (R) (L)	1	PCB
157	FRONT PANEL (R) (R) (R) (R)	1	PCB
158	REAR PANEL (L) (L) (L) (L)	1	PCB
159	REAR PANEL (L) (L) (L) (R)	1	PCB
160	REAR PANEL (L) (L) (R) (L)	1	PCB
161	REAR PANEL (L) (L) (R) (R)	1	PCB
162	REAR PANEL (L) (R) (L) (L)	1	PCB
163	REAR PANEL (L) (R) (L) (R)	1	PCB
164	REAR PANEL (L) (R) (R) (L)	1	PCB
165	REAR PANEL (L) (R) (R) (R)	1	PCB
166	REAR PANEL (R) (L) (L) (L)	1	PCB
167	REAR PANEL (R) (L) (L) (R)	1	PCB
168	REAR PANEL (R) (L) (R) (L)	1	PCB
169	REAR PANEL (R) (L) (R) (R)	1	PCB
170	REAR PANEL (R) (R) (L) (L)	1	PCB
171	REAR PANEL (R) (R) (L) (R)	1	PCB
172	REAR PANEL (R) (R) (R) (L)	1	PCB
173	REAR PANEL (R) (R) (R) (R)	1	PCB
174	TOP COVER (L) (L) (L) (L)	1	PCB
175	TOP COVER (L) (L) (L) (R)	1	PCB
176	TOP COVER (L) (L) (R) (L)	1	PCB
177	TOP COVER (L) (L) (R) (R)	1	PCB
178	TOP COVER (L) (R) (L) (L)	1	PCB
179	TOP COVER (L) (R) (L) (R)	1	PCB
180	TOP COVER (L) (R) (R) (L)	1	PCB
181	TOP COVER (L) (R) (R) (R)	1	PCB
182	TOP COVER (R) (L) (L) (L)	1	PCB
183	TOP COVER (R) (L) (L) (R)	1	PCB
184	TOP COVER (R) (L) (R) (L)	1	PCB
185	TOP COVER (R) (L) (R) (R)	1	PCB
186	TOP COVER (R) (R) (L) (L)	1	PCB
187	TOP COVER (R) (R) (L) (R)	1	PCB
188	TOP COVER (R) (R) (R) (L)	1	PCB
189	TOP COVER (R) (R) (R) (R)	1	PCB
190	BOTTOM COVER (L) (L) (L) (L)	1	PCB
191	BOTTOM COVER (L) (L) (L) (R)	1	PCB
192	BOTTOM COVER (L) (L) (R) (L)	1	PCB
193	BOTTOM COVER (L) (L) (R) (R)	1	PCB
194	BOTTOM COVER (L) (R) (L) (L)	1	PCB
195	BOTTOM COVER (L) (R) (L) (R)	1	PCB
196	BOTTOM COVER (L) (R) (R) (L)	1	PCB
197	BOTTOM COVER (L) (R) (R) (R)	1	PCB
198	BOTTOM COVER (R) (L) (L) (L)	1	PCB
199	BOTTOM COVER (R) (L) (L) (R)	1	PCB
200	BOTTOM COVER (R) (L) (R) (L)	1	PCB
201	BOTTOM COVER (R) (L) (R) (R)	1	PCB
202	BOTTOM COVER (R) (R) (L) (L)	1	PCB
203	BOTTOM COVER (R) (R) (L) (R)	1	PCB
204	BOTTOM COVER (R) (R) (R) (L)	1	PCB
205	BOTTOM COVER (R) (R) (R) (R)	1	PCB