

Garrard

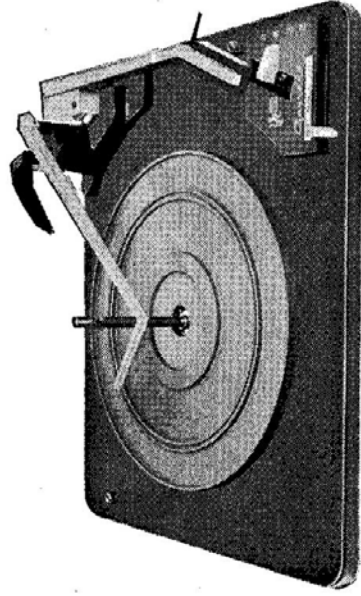

MODEL 1025T

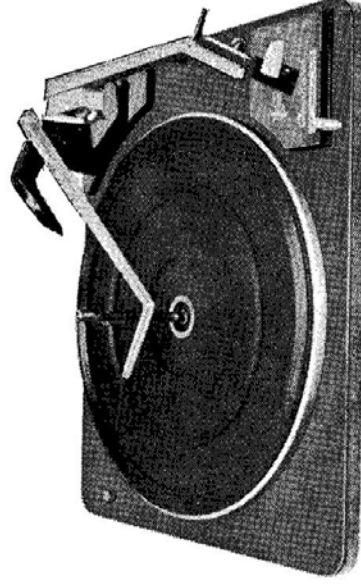

MODEL 2025

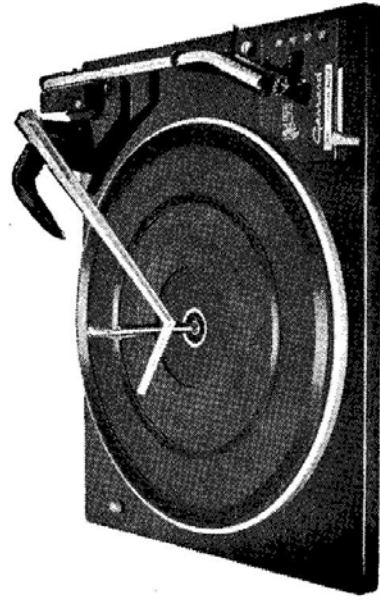

MODEL 2025T

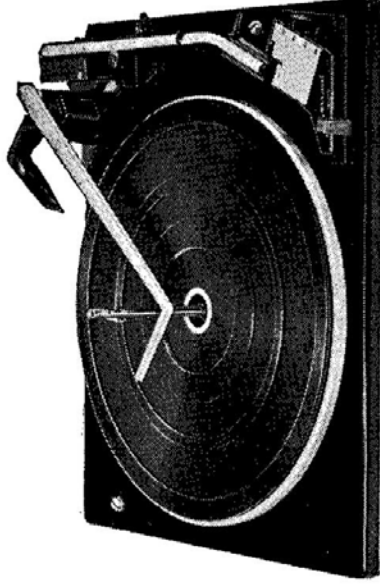

MODEL 2025TC

ALSO MODEL 1025T

ENGINEERS SERVICE MANUAL AND SPARE PARTS LIST

GARRARD ENGINEERING LIMITED
NEWCASTLE STREET - SWINDON - WILTSHIRE - ENGLAND

Enquiries to:

GARRARD ENGINEERING LIMITED
Sales Service Department
KEMBREY STREET
SWINDON, WILTSHIRE, ENGLAND
Telephone: Swindon 6211

Contents

- General Information
 - Operating Instructions
 - Installation and Wiring
 - Maintenance
 - Service Adjustments
 - Exploded Views
 - Spare Parts Lists
 - Fault Chart
-
- Diagram 5 Pickup Muting Switch Connections
 - Diagram 6 Transit Screw Positions
 - Diagram 7 Pickup Lifting Mechanism
 - Diagram 8 Friction Link
 - Diagram 9 Switch-off Lever and Selector Mechanism
 - Diagram 10 Intermediate Wheel Height Adjustment
 - Diagram 11 Pickup Arm Adjustments, Models 1025 and 2025
 - Diagram 12 Pickup Arm Adjustments, Models 2025 and 2025TC
 - Diagram 13 Motor Pulley Identification
 - Diagram 14 Pickup Cueing Mechanism, Model 2025TC
 - Diagram 15 Top View, Model 2025TC Illustrated
 - Diagram 16 Top View with Turntable Removed, Model 1025 Illustrated
 - Diagram 17 Underside View showing Line Cord Socket and Phono Socket
 - Diagram 18 Underside View showing Type 77 2-Pole Motor and Combined Line Cord Socket and Switch

Diagrams

- Diagram 1 Line Cord Circuit Diagram
- Diagram 2 Voltage Changeover Block Connections
- Diagram 3 Phono Socket Connections
- Diagram 4 Pickup Tag Strip Connections

General Information

This manual serves for Garrard Models 1025, 2025, 1025T, 2025T and 2025TC. All these units have the facility to play records automatically and permit single records to be played manually. The mechanisms are similar to those used for the Garrard '50 Series' and '60 Series' of units.

Models 1025 and 2025 have a diecast aluminium pickup arm which accepts a wide range of cartridges. Model 1025 has an 8" diameter turntable and Model 2025 a 10½" diameter turntable.

Model 1025T (8" diameter turntable) and Model 2025T (10½" diameter turntable) are similar to Model 2025, but are fitted with a tubular aluminium pickup arm which is suitable for high and medium compliance cartridges. Model 2025TC has the features of Model 2025T, but in addition it incorporates a cue and pause control.

These Garrard units may have differences, such as turntable trim, which vary according to the code number of the unit (see spare parts list). Also, depending on the code number of the unit, there may be other variables such as type of motor and pickup connector.

In general, two types of motor are employed on these units — Garrard 2-pole or 4-pole induction motors. Normally these motors operate on 100/130 volts A.C. as a low range version or 100/130 volts A.C. and 200/250 volts A.C. as a combined high and low range version with an attached voltage changeover block. The motors run on 50 Hz or 60 Hz power supply depending on the size of motor pulley fitted, which is interchangeable on 4-pole motors. On certain Model 1025 units, the Garrard type BM 32 battery driven motor may be fitted.

On later units the 2-pole motor fitted is the Garrard Type 77 and the 4-pole motor is the Garrard Type 85. Quote these types by name when ordering replacements.

All these models will play automatically up to eight records mixed in any order of 7", 10" or 12" diameter. A short manual spindle is supplied for single record play and large centre hole records may be played automatically using adaptor L.R.S.20 (optional extra) or adaptor type F.L.R.S.35. A single play adaptor is also available for use with large centre hole records.

These units play automatically when the records are of the same speed and record groove type. They can be stopped and started without rejecting the record being played, or records can be rejected as desired. Switch off is automatic after playing the last record. On Model 2025TC the cueing device permits the pickup arm to be accurately positioned on a record by manual means and also allows play to be interrupted when used as a Pause control.

Before using these record changers make sure that the power supply is as indicated on the motor. If the unit is connected to an amplifier whose wiring is not isolated from the power supply, isolating components should be incorporated in the pickup circuit, otherwise the pickup circuit can become live.

Always disconnect the power supply and protect the pickup, when servicing a unit.

As previously stated, components for these models may vary (other than as illustrated) due to the wide variety of customers' specifications. Therefore it is essential, when referring to these models for spares etc., to always quote the code number overstamped on the inspection label of the unit unless a full description can be given (see parts list).

The information in this manual applies to all models covered except where otherwise stated or illustrated.

Garrard units are made to play records complying to B.S. 1928:1965 and I.E.C. Publication 98, and similar standards.

Operating Instructions

Automatic Operation

1. See that the correct stylus is in position for the type of record to be played and free the pickup arm on its rest.
2. See that the speed control is set to the correct speed.
3. Place records horizontally on the record spindle step and swing the overarm fully inwards, on to the top record.
4. Switch on by moving the control to 'Auto', pause and release.
After playing all the records, the pickup arm will return to its rest and the unit will switch off.

To Unload

1. Lift the overarm and swing it to the right.
2. Lift the records clear of the spindle, even if replaying the same records.

Manual Operation

1. Place the record on the turntable by threading it over the record spindle. Swing the overarm fully inwards to its operating position.
2. Switch on by moving the control to 'Manual' and place pickup on the record.
After playing the record the pickup arm will return to its rest and the unit will switch off.
The record spindle may be replaced by a short manual spindle for manual operation.

Installation and Wiring

Cabinet Space

The size of these units is $13\frac{1}{2}$ " (343 mm) wide by $11\frac{3}{8}$ " (289 mm) front to rear by $4\frac{3}{8}$ " (106.5 mm) above and $2\frac{3}{4}$ " (70 mm) below lower edge of unit plate. The latter figure is $2\frac{3}{8}$ " (54 mm) if a 2-pole motor is fitted or if a Model 1025 with a battery motor.

Note, too, that the underside clearance can be cut down slightly on later units fitted with Type 77 and Type 85 motors.

Allowance must be made for clearance around the unit by adding $\frac{1}{2}$ " (12 mm) to all dimensions stated here. This will give $\frac{1}{2}$ " (6 mm) clearance all round edge of unit and $\frac{1}{2}$ " (12 mm) above and $\frac{1}{2}$ " (12 mm) below, allowing unit to float freely on its mounting springs and be clamped for transit.

According to the design of the cabinet or case, additional clearance may be required around the control area and for record handling, also as clearance for 12" records and removal of record spindle.

Reject

A record being played may be rejected by moving the control to 'Auto'.

Stop

Move the control to 'Off' and the motor will stop with the pickup remaining on the record. Restart by moving the control to 'Manual' and the same record will continue playing.

Cueing Device (Model 2025TC only)

The pickup can be raised or lowered on to any record on the turntable by operating the cueing lever. This lever can also be used for interrupting either Auto or Manual play for a short time by moving it backwards to lift the pickup from the record.

To resume play, move the lever steadily forwards to lower the pickup on to the record.

Note:

To avoid damage to the stylus, do not move the control to 'Auto' until records are loaded on the record spindle. Do not leave records on the unit when not in use. Keep the stylus point free from dust. To obtain best results from records, store and clean them as recommended by the record manufacturers.

Unpacking

When unpacking a unit, withdraw it and its polyfoam pack from its carton by lifting while gripping the sides of the unit plate. Never lift the unit by its pickup arm or overarm. Carefully remove all packing ties, rubber bands, polythene sleeves and cardboard fittings — which may include a wedge between the motor and unit plate. Accessories are found in the cavities of the polyfoam pack.

Preparing Motor Board

If it is necessary to prepare a mounting board, do so by drilling and cutting out the board to the paper template supplied with each unit. Do not moisten the template, but fix it to the mounting board with adhesive tape. Recommended board thickness is between $\frac{1}{8}$ " and $\frac{1}{2}$ ". Should a thicker board be used, it may be necessary to recess the $\frac{1}{8}$ " diameter holes from the underside to $1\frac{1}{8}$ " diameter, to clear the transit screw clips.

Motor Wiring

Before assembling the unit into the cabinet, connect a power supply lead to the terminals in the voltage changeover block if a high and low voltage motor is fitted. Connect an earth lead to the earthing tag on the motor or earth screw terminal. Use the convention of brown for 'live', blue for 'neutral' and green/yellow for 'earth' when choosing power supply leads. A connecting plug and socket (line cord) may already be fitted on certain units — diagram 1 illustrates the low voltage range circuit when this is so. Diagram 2 shows the power supply connections when a voltage changeover block is fitted.

Many of these units have a switch click suppressor connected across the switch contacts, consisting of a capacitor, Erie type K350081/811, 10,000PF + 80% - 20%, wired across the switch blades. On most of these units this forms part of the plug-in loom assembly.

Pickup Wiring

Screened leads should be connected to the pickup tag strip, or on some units the tags on the muting switch, suitable for connection to the amplifier as shown on diagrams 4 and 5. Certain units have phono sockets fitted to which phono leads may be connected, see diagram 3.

When a stereo pickup is used with a mono amplifier, parallel the right and left channels.

Before connecting the record changer to the amplifier, make sure that the pickup circuit of the radio set or amplifier to which it is to be connected is isolated from the power supply. If it is not then it is essential for isolating components to be incorporated in the pickup circuit. The pickup lead should be kept as short as possible and its screening connected to a good earth.

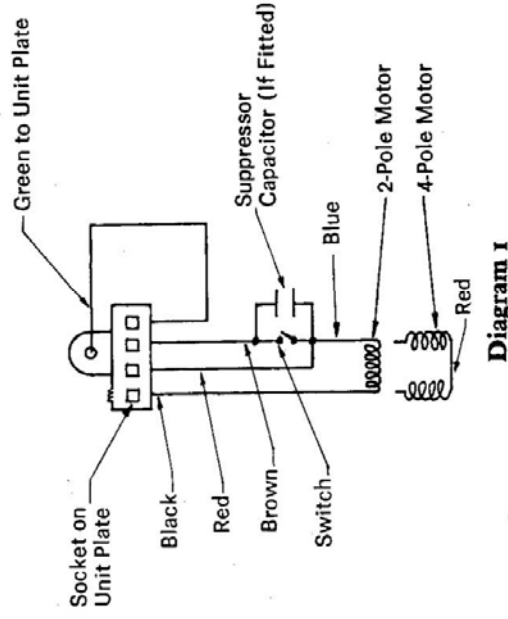
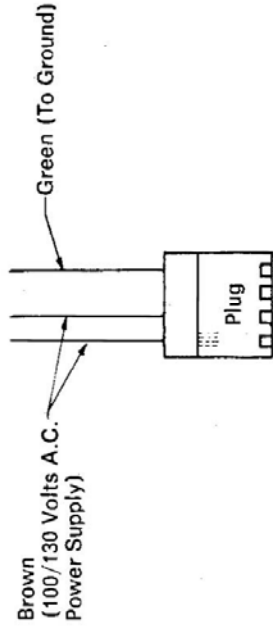

Diagram 1

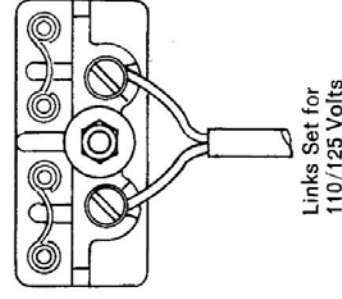
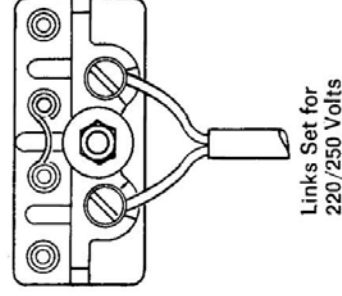

Diagram 2

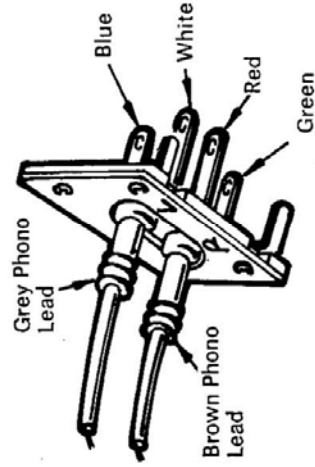

Diagram 3

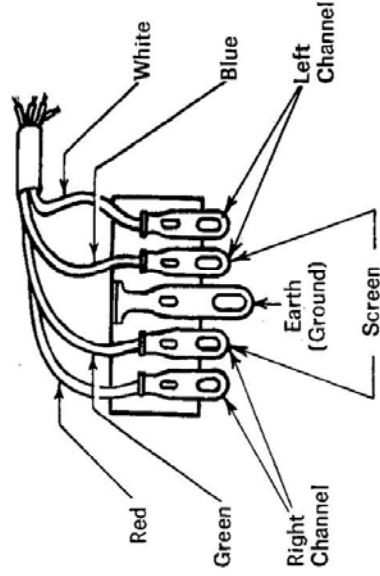

Diagram 4

Fitting Cartridge

These units accept a wide range of cartridges and in cases where a unit is supplied less cartridge, information on its connections is usually supplied with the chosen cartridge. Models 1025 and 2025 have the standard $\frac{1}{2}$ " spaced, 2 hole fixing arrangement for cartridges, plus a tapped hole for single hole, central fixing. Models 1025T, 2025T and 2025TC have only provision for single hole, central fixing. Garrard pickup hardware kit, part number 59048, supplies screws of the approximate length for fixing most cartridges; other kits are available according to the type of cartridge.

When connecting the colour coded leads in the pickup head to the connection tags on the cartridge, remove the tags, do not solder directly, as this may damage the cartridge elements. If the cartridge terminations are sockets, a special connector must be used.

Garrard units are made with the pickup wiring colour coded as follows:—

- Red — Right Channel Signal
- Green — Right Channel Ground
- White — Left Channel Signal
- Blue — Left Channel Ground (Black on later models)

For cartridges having 3 connections, use the green lead as the common connection or join the green and blue leads together and use these as the common connection. For mono cartridges use the red and green leads. Insulate and tuck away any leads not required.

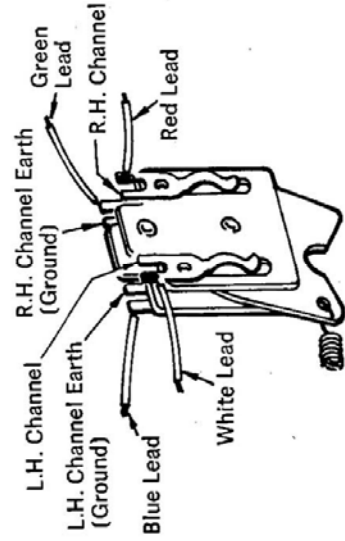

Diagram 5

Fitting Unit in Cabinet

The unit should be placed on the board so that the spring mountings locate correctly and the transit screws go through their respective holes. When in position, the spring locks on the ends of the transit screws should be turned through 90° so that they lie parallel to the mounting board, as in diagram 6.

In use, check that the 2 transit screws are screwed down clockwise and that the unit is floating freely on its mounting springs. Before transit, turn the transit screws counterclockwise, so that the unit is held against the mounting board as in diagram 6.

Note that all these units will fit the appropriate Garrard Mounting Bases; rigid plastic covers are also available.

Setting up for Play

Fit the record spindle in the turntable spindle, taking care in locating it, as it is held in position by the turntable retaining clip.

As a check on the mechanism, revolve the turntable slowly clockwise by hand, use an unvalued record for setting up purposes and with power supply disconnected, operate the Auto control to see that the mechanism cycles correctly.

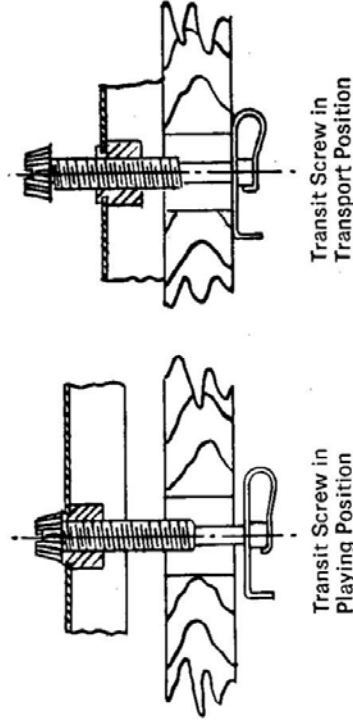

Diagram 6

Maintenance

Disconnect the power supply and protect pickup before carrying out maintenance.

To remove turntable

Pull out the record spindle (61) from its location, then remove the turntable retaining clip (59) using a small screwdriver and noting the clip's location for correct reassembly — small hole facing rear, left. Now lift the turntable with equal pressure on diametrically opposite sides.

When replacing the turntable, check that the tooth gap on the cam gear (76) is adjacent to the turntable spindle and that the automatic trip pawl (74) is pushed clear of the turntable spindle. Replace the turntable retaining clip (59) taking care that the clip and record spindle (61) locate correctly.

The overarm

When swung fully inwards, the overarm must drop freely in its location. If stiff, remove circlip, washer and spring, on overarm spindle (beneath unit), withdraw overarm and clean and oil its spindle, also check that spring (197) assists in positive dropping of overarm.

Lubrication

The bearings of the motor, turntable spindle and rubber intermediate wheel (49) are of the oil retaining type and rarely need lubricating. When the need for oil is apparent, remove the turntable and lubricate these bearings with a fine grade of machine oil. Carefully remove excess oil, particularly from the motor pulley, rubber intermediate wheel (49) and inside turntable rim by wiping these driving surfaces with a clean cloth.

Other pivots or working faces may need oil or grease from time to time. They are:—

1. Pivots (5) for vertical movement of Models 1025 and 2025 pickup arm — a spot of thin oil.

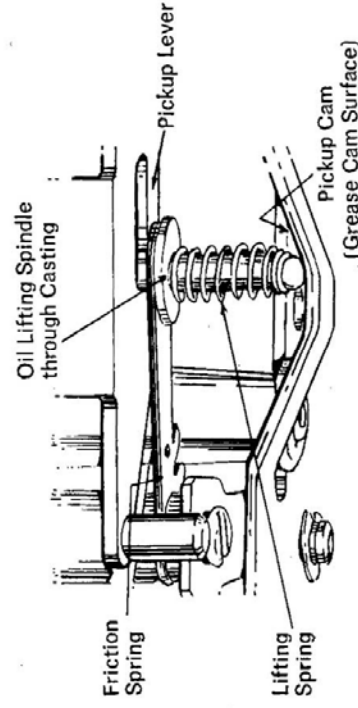

Diagram 7

2. Pivots (10) for horizontal pickup arm movement — a spot of thin oil.

3. Oil overarm lever on lower casting (153) where it contacts overarm spindle (65).

4. Oil overarm spindle (65) through hole in lower casting (153) so that the overarm drops freely when in its inward position.

5. Oil spindle of cam (76).

6. Friction link (165) apply a spot of thin oil, as in diagram 8.

A smear of grease may be applied occasionally at the following points:—

1. Control lever (142), working face against pin in switch lever (192).

2. Unit plate where switch lever pin (192) rubs.

3. Pickup cam (167), working area and end of lifting spindle (155) as in diagram 7.

4. (a) Pillar in pickup cam (167), running in unit plate slot.

- (b) Washer on lower casting (153), where it rubs pickup cam (167), see diagram 9.

- (c) Face of pickup cam (167) operating switch off lever on lower casting (153), see diagram 9.

5. Release lever (208), operating face against pin in pickup cam (167).

6. Track of cam (76).

7. Speed cam (178), top and side faces.

8. Support lever pin (180), operating face.

9. Switch off lever on lower casting (153), slot, ends of lever and underside of unit plate.

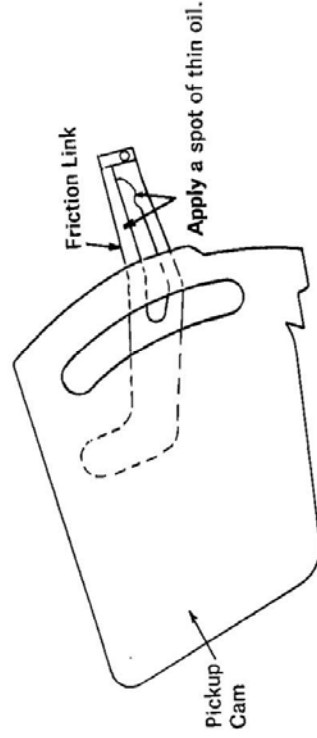

Diagram 8

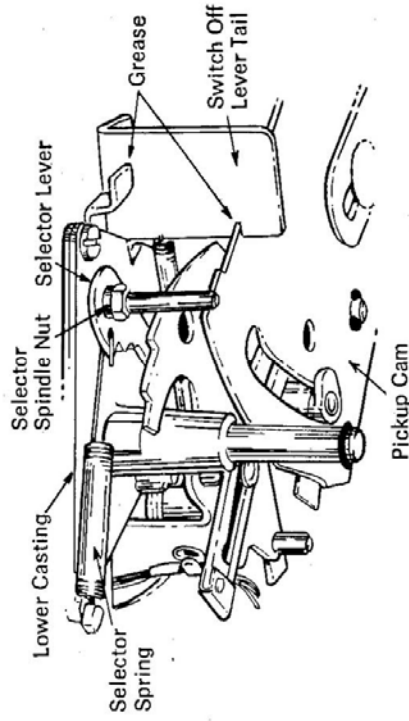

Diagram 9

Service Adjustments

Before making any adjustment, always disconnect the power supply and protect the stylus. If necessary, operate the controls and rotate the turntable clockwise by hand to actuate the mechanism.

Speed

If the turntable speed varies other than because of warped records slipping, remove the turntable and clean the driving surfaces as stated under 'Maintenance'. Should the turntable run fast or slow consistently, check that the motor and motor pulley match the power supply. The motor is labelled or stamped with its power supply details and the motor pulley, if the removable type, may be colour finished for identification, nickel for 50 Hz and brass for 60 Hz power supply or on later units, identified by pulley base being larger than 78 rev/min step for 60 Hz and smaller for 50 Hz. If a 4-pole motor pulley (176) check that the grub screws are tight. The 2-pole motor pulley is integral with the shaft and is not removable.

Check that the rubber intermediate wheel (49) runs in the centre of the appropriate pulley step and is not rubbing the side of the adjacent step. If necessary adjust the intermediate wheel height setting blade. This blue spring steel blade adjusts the position of the spindle on which the rubber intermediate wheel (49) is mounted. See diagram 10.

Pickup Tracking

Should there be a tendency for the pickup to track incorrectly, check that the correct stylus is in use and clean any dust build-up from the stylus. Make sure the stylus force is correct for the cartridge fitted and see that the leads from the pickup are free and not rubbing any mechanism. Also see that the unit is reasonably level.

Pickup Muting Switch

On some models a muting switch (187) is fitted, which short circuits the pickup connections during the time that the changing mechanism is in action. If this fails to operate,

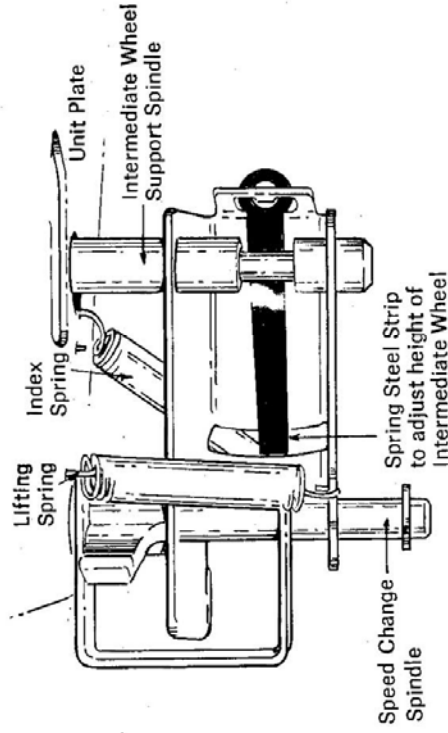

Diagram 10

check that the contacts are making and breaking correctly and that the wiring is secure. See that the bracket on which the muting switch is mounted is correctly positioned against the two small half-pierced lugs in the unit plate. If it is not, loosen the bracket fixing screw and position the switch correctly.

Pickup Lowering Position

Turn adjusting screw (C), shown in diagrams 11 and 12 counterclockwise to move the arm outwards, or clockwise to move it inwards. Setting for one standard record size automatically sets for the other standard sizes as well (7", 10" and 12").

Pickup Height

When on auto cycle, the pickup must clear a full stack of records on the turntable while returning to its rest, also the underside of any record on the record spindle step. For this condition, turn adjusting screw (A) counterclockwise to raise or clockwise to lower pickup height, so that stylus tip is $\frac{3}{4}$ " (Model 1025 $\frac{7}{8}$ ") above a single record on the turntable as the arm returns to its rest. See diagrams 11 and 12. If a cartridge is fitted with an overall depth greater than that in the normal range, this setting may need to be reduced, which decreases the number of records that can be played in automatic sequence.

Pickup lowering position and height are best adjusted with the power supply disconnected. Load a single record on the record spindle step, switch on to 'Auto' and operate the changer cycle by revolving the turntable clockwise by hand.

Pickup Arm Lifting Height Restrictor

When a restrictor is fitted it acts as a catch preventing excess vertical movement from damaging the pickup. Pressing the restrictor (B) inwards, allows the pickup arm to be raised in order to examine the pickup cartridge. See diagrams 11 and 12.

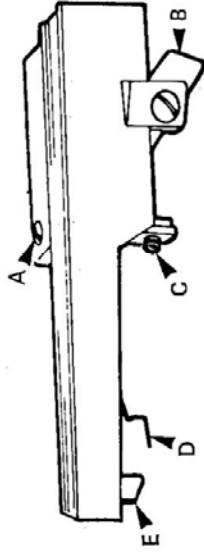

Diagram 11

Stylus Force

On Models 1025 and 2025 to reduce stylus force, pull ratchet finger (E) forwards. To increase force, pull spring (D) downwards taking care as ratchet finger (E) springs back, then reduce force as much as is necessary. See diagram 11. On Models 1025T, 2025T and 2025TC to adjust stylus force first press restrictor (B) from its catch position to raise pickup arm, then unhook adjusting spring (D) from plate (E) and refasten it in a higher hole to reduce force or a lower hole to increase stylus force. See diagram 12.

If a cartridge is already fitted, this will have been pre-set to the stylus force recommended by the cartridge manufacturer and any stylus force adjustments should always be made to the figure recommended, using a reliable stylus force gauge as a check.

To Remove Motor Pulley

The pulley has minimum clearance between its bore and the motor shaft, to ensure true running. If, with its locking screws loosened, the pulley is tight on the shaft, apply gentle heat to the base of the pulley for about 30 seconds using a small, clean soldering iron; the pulley should then slide off easily. Use this method to fit a new pulley if necessary (applies to 4-pole motors only), but take care not to damage the intermediate wheel or motor wiring when using a soldering iron.

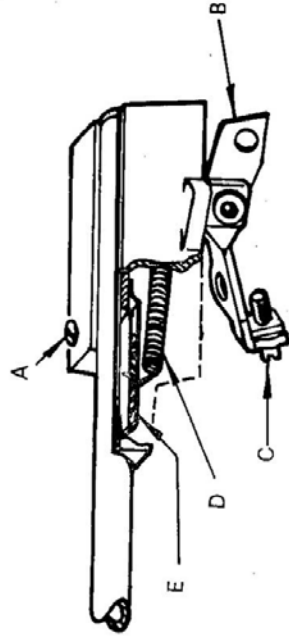

Diagram 12

Pickup Cueing Height (Model 2025TC)

Later models of this type have an independent adjustment for the height to which the pickup can be manually cued. Normally this height should be set to $\frac{3}{4}$ " between stylus tip and one record on the turntable. Turn the cueing adjustment screw shown in diagram 14 clockwise to increase cueing height or counterclockwise to decrease height. On the earlier version of this unit the cueing height is adjusted by altering the position of the square cast collar found on top of the lifting spindle (155). The collar is secured by a grub screw.

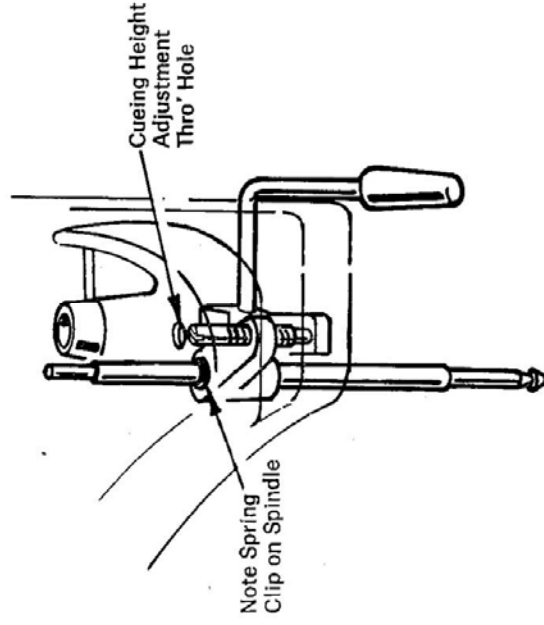
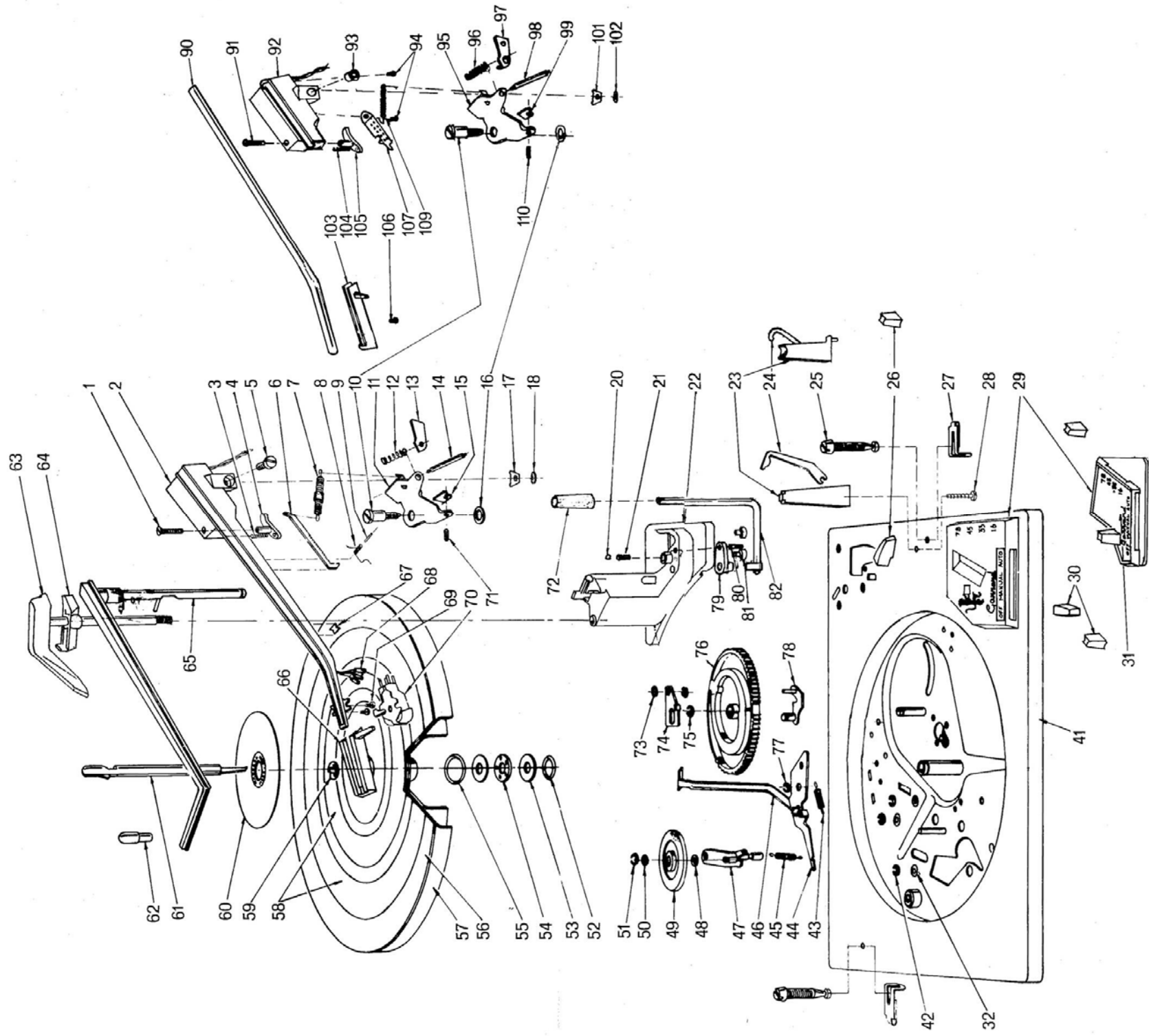

Diagram 13



PARTS SHOWN ABOVE UNIT PLATE

Spare Parts List Models 1025, 2025, 1025T, 2025T, 2025TC

When referring to these units it is essential to quote the model type and code number. The code number is over stamped on the inspection label taped to the underside of the unit plate.

On Model 1025 the code number is 73625 plus its following 3-figure stroke number.

On Model 2025 the code number is 73650 plus its following 3-figure stroke number.

On Model 1025T the code number is 75650 plus its following 3-figure stroke number.

On Model 2025T the code number is 73830 plus its following 3-figure stroke number.

On Model 2025TC the code number is 73750 plus its following 3-figure stroke number.

In addition when ordering spares, quote the part number and colour or voltage range, if applicable.

Ref. No.	Part No.	Description	Ref. No.	Part No.	Description
1	44188	Adjusting Screw	25	44120	Transit Screw (2)
2	73110	Pickup Arm Casting	26	70407	Knob, Speed Control Lever
3	44957	Overload Spring	26	72507	Knob, Speed Control Lever — 2025TC
4	73115	Adjusting Platform	27	43855	Spring Clip, for Transit Screw (2)
5	70155	Pivot Screw	28	44125	Screw, for Pickup Rest
6	59988	Adjusting Plate, for Stylus Force Spring	29	73639	Control Cover Moulding
7	72042	Spring, Stylus Force (Green)	29	72500	Control Cover Moulding — 2025TC (complete)
7	71556	Spring, Stylus Force (Silver) 1025			(inc. 31)
7	73522	Spring, Stylus Force (Dark Yellow) 2025	30	70410	Knob, for operating Control Lever
8	44762	Index Spring	30	72507	Knob, for operating Control Lever — 2025TC
9	70095	Pin, for Index Spring	31	73780	Decor Plate — 2025TC
10	44207	Pivot Screw (Top)	32	40695	Washer, Motor Mount
11	73124	Pickup Bracket			(4-pole only)
12	44956	Spring, for Restrictor	41	73664	Unit Plate, with Pins, Bushes, etc.
13	73123	Restrictor, for Pickup Arm	42	43863	Spring Clip, for Motor (3) 2-pole
14	59993	Pivot Spindle	42	41723	Spring Clip, for Motor (3) 4-pole
15	71217	Locking Clip, for Adjusting Screw	43	41503	Spring, for Tension Lever
16	40504	Washer, for Pivot Screw	44	71357	Tension Lever
17	40928	Washer, for Pickup Lead	45	44819	Spring, for Support Lever
18	43809	Spring Clip	46	71824	Tension Link
20	43200	Ball	47	71545	Support Lever, for Intermediate Wheel
21	41987	Spring	48	40826	Fibre Washer
22	73629	Upper Casting	49	58220	Intermediate Wheel
23	73116	Pickup Rest Body — 1025, 2025	50	40985	Nylon Washer
23	73145	Pickup Rest Assembly with Clip — 1025, 2025	51	43818	Spring Clip
23	73537	Pickup Rest Body — 1025T, 2025T, 2025TC	52	58749	Cushion Ring
23	73552	Pickup Rest Assembly with Clip — 1025T, 2025T, 2025TC	53	40894	Thrust Washer (2)
24	73117	Clip, for Pickup Rest — 1025, 2025	54	58229	Ball Race
24	73538	Clip, for Pickup Rest — 1025T, 2025T, 2025TC	55	73139	'O' Ring, for Turntable

Ref. No.	Part No.	Description	Ref. No.	Part No.	Description
56	73077	Turntable Mat (Model 1025)	79	73669	Lifting Bracket — 2025TC
56	73078	Turntable Mat (Model 2025, 2025T, 2025TC)	80	44329	Adjusting Screw — 2025TC
57	70941	Turntable with Mat and Trim Ring (Model 1025)	81	72997	Bearing Pad — 2025TC
57	73066	Turntable with Mat and Trim Ring (Model 2025, 2025T, 2025TC)	82	73646	Cueing Lever Unit — 2025TC
58	73029	Trim Ring, Large 9" for Mat (if fitted)	90	73536	P.U. Arm Tube
58	73030	Trim Ring, Small 6" (if fitted)	91	44188	Screw (P.U. Height Adjustment)
59	43834	Spring Clip, for turntable	92	73535	P.U. Arm Body
60	70916	Centre Disc for Turntable 1 $\frac{1}{8}$ " dia. (Model 1025)	93	73541	P.U. Arm Bearing
60	73539	Centre Disc for Turntable 1 $\frac{1}{8}$ " dia. (Model 2025, 2025T, 2025TC)	94	44159	Screw (2)
61	70932	Automatic Record Spindle	95	73124	P.U. Bracket Assembly complete (inc. 99-110)
62	72094	Manual Record Spindle (Black Nylon)	96	44956	Spring
63	70936	Selector Arm	97	73123	Restrictor
64	70938	Selector Extension	98	59993	Spindle
65	73401	Overarm	99	71217	Locking Clip
66	73119	Pickup Shell	100		
67	43836	Clip, for Pickup Lead	101	40928	Washer Presspahn
68	71478	Lead, for Pickup Arm (please state Cartridge Type)	102	43809	Clip
69	44185	Screw, for cartridge (2) 6 B.A. x $\frac{1}{8}$ "	103	73534	P.U. Head
		Other screw lengths listed see Ref. 106	104	44957	Spring
70		Pickup Cartridge — not made by Garrard.	105	73115	Height Adjusting Platform
		State type	106	40454	Screw 6 B.A. x $\frac{5}{32}$ " (Thin Head)
71	44210	Adjusting Screw	106	00245/057	Screw 6 B.A. x $\frac{1}{4}$ "
72	72748	Knob Cueing Lever — 2025TC	106	40295	Screw 6 B.A. x $\frac{7}{32}$ " (Thin Head)
73	41723	Spring Clip (2)	106	40430	Screw 6 B.A. x $\frac{3}{16}$ " (Thin Head)
74	58335	Trip Pawl	107	73549	Stylus Force Rack
75	41788	Spring Clip	108		
76	58328	Main Cam, with Pawl and Plate	109	44979	Stylus Force Spring (Silver)
77	41723	Spring Clip (2)	109	44993	Stylus Force Spring (Red)
78	58331	Pivot Plate	110	44210	Adjusting Screw

Items 90-110 show 1025T, 2025T and 2025TC

PARTS SHOWN BELOW UNIT PLATE

Spare Parts List Models 1025, 2025, 1025T, 2025T, 2025TC

When referring to these units it is essential to quote the model type and code number. The code number is over stamped on the inspection label taped to the underside of the unit plate.

On Model 1025 the code number is 73625 plus its following 3-figure stroke number.

On Model 2025 the code number is 73650 plus its following 3-figure stroke number.

On Model 1025T the code number is 75650 plus its following 3-figure stroke number.

On Model 2025T the code number is 73830 plus its following 3-figure stroke number.

On Model 2025TC the code number is 73750 plus its following 3-figure stroke number.

In addition when ordering spares, quote the part number and colour or voltage range, if applicable.

Ref. No.	Part No.	Description	Ref. No.	Part No.	Description
142	70408	Operating Control Lever, with Knob	176	60846	50Hz Pulley for Type 85 motor
142	72508	Operating Control Lever, with knob (2025TC only)	176	60845	60Hz Pulley for Type 85 motor
143	70405	Speed Control Lever, with Knob	177	60391	Earth Lead
143	72506	Speed Control Lever, with Knob (2025TC only)	178	70218	Speed Cam
144	71138	Return Spring, with Sleeve	179	43858	Spring Clip
146	41723	Spring Clip	180	58208	Support Bracket, with Blade
147	58327	Reject Lever	181	41848	Index Spring
152	44125	Screw (2)	182	58211	Index Bracket with Roller
153	73634	Lower Casting	183	73542	Spring Mounting, with Damping Pad (3)
154	44154	Screw	184	44708	Lifting Spring
155	73841	Lifting Spindle (1025, 2025)	185	71971	Clip, fixing Motor Lead (2)
155	73841	Lifting Spindle (2025T, 2025TC)	186	41503	Spring
156	44711	Overload Spring	187	71536	Muting Switch, with Phono Socket
157	43865	Clip Lifting Spindle (2025TC)		58862	Muting Switch, for Models without Phono Socket
160	70329	Pickup Lever	188	73532	Twin Phono Socket
161	41985	Friction Spring		58356	Pickup Lead Tag-Strip (not shown)
162	40514	Washer	189	44126	Screw
163	41986	Spring	190	41723	Spring Clip
164	58316	Collar	191	58274	Speed Lever
165	58348	Friction Link	192	58310	Switch Lever
166	41723	Spring Clip (2)	193	41723	Spring Clip
167	73632	Pickup Cam	194	44825	Spring
167	58958	Pickup Cam fitted to Units with Muting Switch	195	42500	Shakeproof Washer
168	71362	Return Spring	196	44126	Screw
169	01577/006	Self Tap Screw Securing Switch (2)	197	44855	Spring
171	44154	Screw	198	40967	Washer
172	59310	Insulating Plate	199	43813	Spring Clip
173	60365	Wiring Loom for Motor, with Switch etc.	200	58303	Selector Lever
174	60350	Motor 4-pole without Loom, state voltage	201	42513	Shakeproof Washer
174	60660	Type 85 4-pole motor (marked on cover)	202	41007	Nut
174	60373	Motor 2-pole without Loom, state voltage	203	44706	Spring
174	60580	Type 77 2-pole motor (marked on cover)	204	43200	Ball
175	43129	Mounting for 4-pole Motor (3)	205	72681	Auto Trip Link
175	43140	Mounting for 2-pole Motor (3)	206	44133	Screw
176	58920	Motor Pulley, 50 Hz	207	41759	Pawl Spring
	58921	Motor Pulley, 60 Hz	208	71637	Release Lever

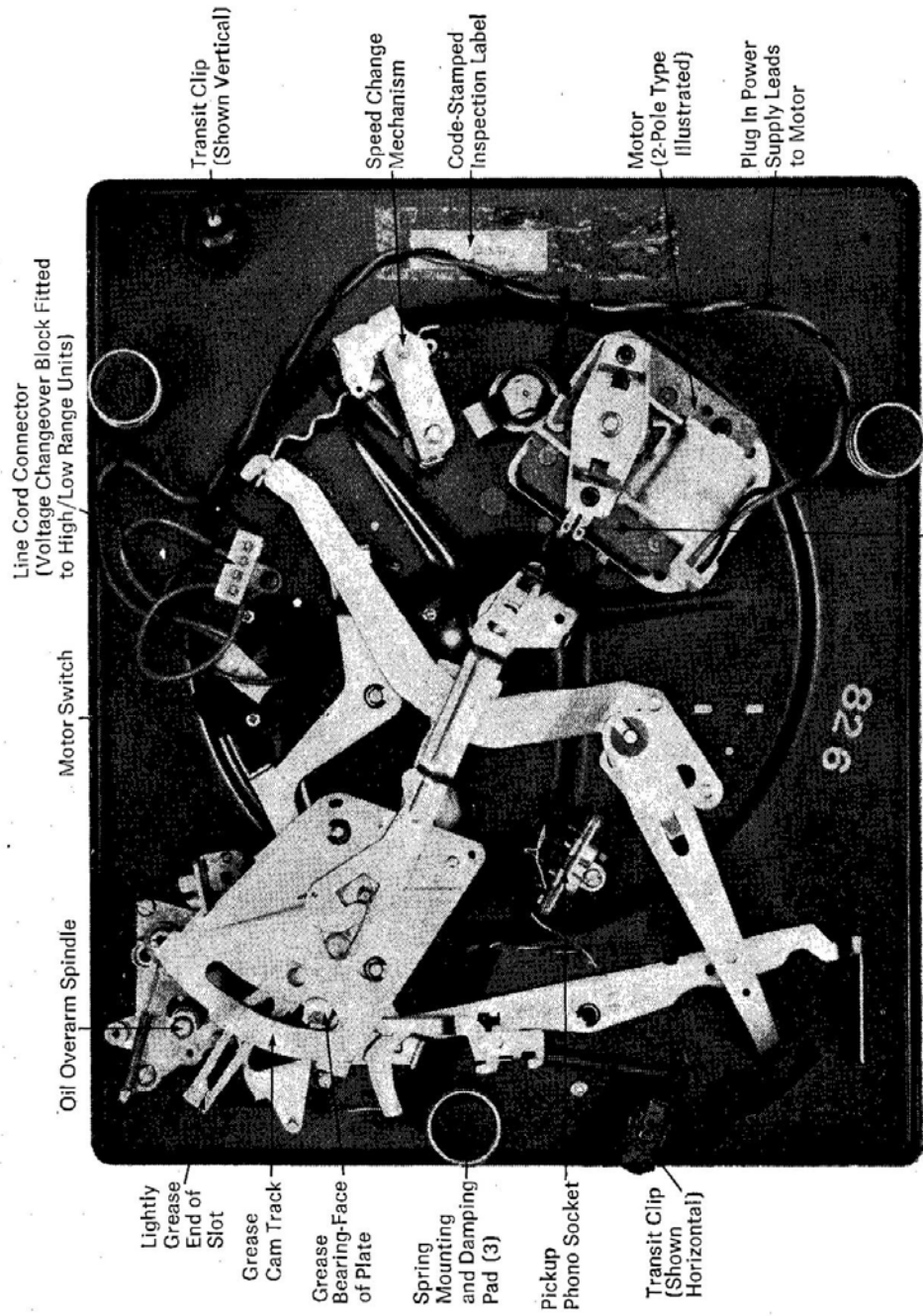

Motor Earth Tag
(If not earthed through line cord)

Lightly Oil All Pivot Points

Diagram 16

'Flying' Motor Leads.
Garrard units supplied to
Radiogram manufacturers, may
be wired in this way.

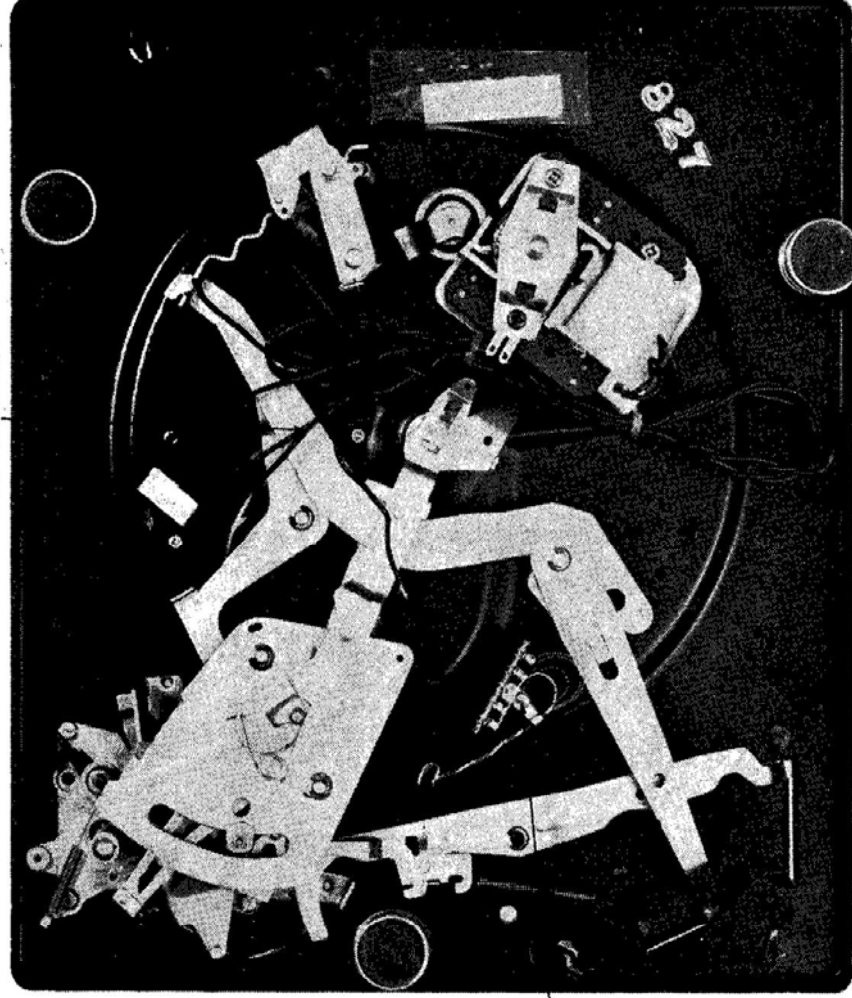
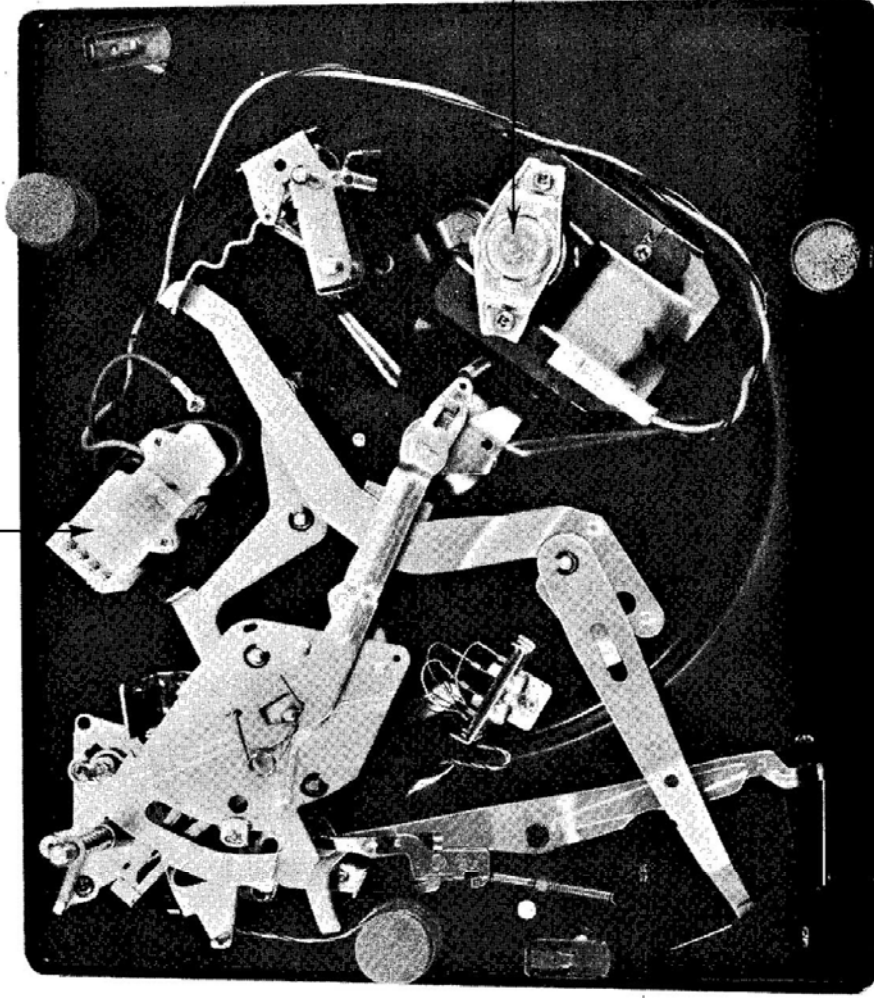

Diagram 17

Combined Line Cord Socket
and Switch



Type 77 2-Pole Motor
marked on Bearing
Cover

Diagram 18

DISCONNECT THE POWER SUPPLY BEFORE SERVICING A UNIT

The unit should be disconnected from its power supply and the stylus protected before servicing, whenever possible. Numbers in brackets refer to parts shown on the exploded view. References to "Motor Pulley" apply only to units with 4-pole motors.

FAULT	CAUSE	CORRECTION
Turntable Speed. A. Turntable fails to start, or runs slowly when switched on.	<ol style="list-style-type: none">1. Oil or dirt on driving surfaces.2. Faulty intermediate wheel spring (45).3. Intermediate wheel support bracket (180) not free.4. No voltage or low voltage at motor (174).5. Faulty motor coil(s).6. Bearings of motor (174) out of line.7. Motor pulley (176) or intermediate wheel (49) height set incorrectly.8. Bearings not free.	<p>Remove turntable (57) and clean inside rim, intermediate wheel (49) and motor pulley (176).</p> <p>Check that spring is secured. Move operating control to 'Manual' — spring should stretch. If it does not, replace it.</p> <p>Wheel (49) should engage motor pulley (176) firmly when switched on and retract when switched off. If not, replace damaged parts or lightly oil spindles.</p> <p>Remove plug from motor, switch on, and check with voltmeter. If no power, check back to source outlet, looking for loose connections, faulty switch contacts, etc. Voltage should not be lower than 100V for 100/130 volt A.C. motor or 200V for 200/250 volt A.C. motor.</p> <p>Remove plug from motor (174) to check continuity of coil, with ohm-meter. Replace motor if necessary.</p> <p>If rotor does not spin freely, tap the motor body with a small block of wood (e.g., screwdriver handle) to re-align bearings. Use only thin machine oil on these bearings; thick oil will clog them.</p> <p>See 'Service Adjustments'. Check that both motor pulley screws are tight.</p> <p>Check motor, intermediate wheel and turntable bearings. Clean and lightly oil, if necessary — see 'Maintenance'.</p>
B. Turntable speed varies (wow and flutter).	<ol style="list-style-type: none">1. Various.2. Warped records in stack slipping.3. Damaged rotor shaft.4. Flats on driving surface of intermediate wheel (49).	<p>See Fault A, Causes and Corrections 1, 7 and 8.</p> <p>If strips of adhesive tape on labels does not help, play warped records singly.</p> <p>Replace motor (174).</p> <p>If running for a few hours does not cure the fault, replace wheel.</p>
Record Dropping. C. Records fail to drop.	<ol style="list-style-type: none">1. Damaged record spindle (61).2. Record overarm (65) not free.3. Label paper in centre hole of new record.4. Non-standard records.5. Release lever return spring (168) or pawl spring (207) weak or disengaged.	<p>Remove spindle and check that it is straight and that its record pushing pawl moves freely. If not, replace spindle.</p> <p>This should fall freely under its own weight. It should rest flat on top of record stack. Clean and lightly oil its spindle if necessary.</p> <p>Remove it carefully with a pen knife or ream hole with pencil.</p> <p>Records with oversized centre holes or more than 0.090" thick at centre hole may fail to drop. Play them manually.</p> <p>Replace or re-secure.</p>
D. Two or more records drop together.	<ol style="list-style-type: none">1. Damaged record spindle.2. Non-standard records.	<p>Check that both latches at the top of the spindle (61) fall freely. Do not oil them. Replace spindle, if necessary.</p> <p>Records less than 0.053" thick at centre holes. Play them singly.</p>

FAULT**CAUSE****CORRECTION****Pickup Arm Movement.**

- E. Pickup tracks incorrectly.**
1. Stylus force too low. Check that force is not lower than recommended. Reset if necessary — see 'Service Adjustments'.
Clean carefully.
 2. Dust accumulated around stylus tip. Slacken them and check that they are not caught in mechanism below unit plate.
Replace stylus.
 3. Pickup leads (68) tight or trapped. If stylus lands too far out it may slide down the slope of the raised rim and jump the first playing grooves. Set lowering position so that stylus lands well inside the raised rim. See 'Service Adjustments'.
 4. Worn or wrong stylus. Apply a spot of thin oil.
 5. Groove guard on record. Move pickup inwards by hand checking for damaged linkage. Reshape or replace, as necessary.
Replace, as necessary.
 6. Excessive friction in friction link (165). Tighten fixing screw (106) or reshape cartridge bracket.
 7. Automatic trip links (74, 78, 205) not free.
 8. Damaged pickup pivots or bearing (10, 14, 93, 98).
 9. Body of cartridge (70) touches record.

F. Pickup lands on record too far out and/or in.

1. Lowering position incorrectly set. See 'Service Adjustments'.
2. Selector lever (202) nut loose. Check that nut (202) is tight to ensure that selector lever (200) is securely held.
3. Selector (63) damaged or out of position. Check that the selector (63) is not damaged. With no record on automatic spindle (61) and power turned off, switch operating control lever to 'Auto' and revolve the turntable clockwise by hand. Watch record spindle pawl as it moves across record spindle step. Stop revolving the turntable when the pawl reaches its outermost position. Then with the overarm (65) in its operating position, check that tip of the selector arm is between $4\frac{3}{4}$ " and $4\frac{1}{4}$ " radius from the turntable centre. Also, move separately 10", then 12" record slowly down the record spindle and make sure that the selector lever (200) catches into its 10" and 12" selecting positions.
Apply a spot of thin oil.
4. Friction link (165) requires lubrication. Move overarm (65) to operating position, then move selector arm (63) by hand away from the turntable centre; it should return by light spring pressure. If it does not, check that selector spring (203) is correctly assembled to lower casting (153) and selector lever (200). If it has stretched, replace it.
5. Selector spring (203) weak or incorrectly assembled.

1. Cueing lever lifted (205TC only).

Lower cueing lever.

G. Pickup arm fails to lower.

1. Cueing lever lifted (205TC only). Lower cueing lever.
2. Lifting spindle (155) not free. With pickup arm raised, if the lifting spindle is also raised by its top, it should spring back. If not, check for damage and freeness. Clean and oil if necessary.
Check for damage.
3. Pickup arm pivot, bearing and spindle (14, 93, 98) not free.

FAULT**CAUSE****CORRECTION**

H. Pickup begins to lower, then swings in.	1. Pickup leads (68) tight or trapped. 2. Lifting spring (163) or friction spring (161) binding.	Slacken them if necessary and see that they are not caught in mechanism, below unit plate. Check that lifting spring is secure and moves freely. With lifting spring held clear, deflect friction spring away from pickup cam (167); it should spring back when released. Replace damaged spring(s).
I. Pickup fails to lift and return at the end of the record.	1. Damaged trip pawl (74).	Reshape vertical lug, or replace pawl.
J. Pickup lands on record and immediately rejects, next record drops and fault repeats until normal switch off at end of a stack.	1. Return spring (168) disengaged. 2. Operating control lever (142) jammed. 3. Trip pawl (74) bent into turntable mesh.	Attach it to hole in release lever (208) and pin on pickup cam (167). Check operation of return spring (144) and grease sliding surfaces of control lever and unit plate. Lightly oil pivot of lever. Straighten trip pawl (74) or replace.
K. Rumble, heard through speaker(s) while stylus is in blank record groove.	1. Lack of lubrication. 2. Intermediate wheel (49) side rubbing against motor pulley. 3. Driving surface of intermediate wheel (49) dirty, indented or hardened. 4. Faulty installation. 5. Worn turntable bearings.	See 'Maintenance'. Check heights of wheel and pulley — see 'Service Adjustments'. If cleaning the surface of the wheel and running the unit for a few hours does not help, replace it. Check that unit floats freely on its mounting springs, that the motor hangs freely in its rubber grommets and that no part of the mechanism is in contact with the mounting board. Replace thrust washers (53), ball race (54) and/or cushion ring (52), as necessary.
L. Gear noise during change cycle.	1. Worn damping ring (55).	Replace damping ring (55) on bottom of turntable boss.
M. Electrical interference, heard as crackles, etc. through speaker(s).	1. Faulty contact in power supply circuit, pickup circuit or earth connections. 2. Faulty suppressor.	Examine all leads and connections for damage and check screws for tightness. Remove screws (169) holding motor switch, take off cover and check for good contact between blades. Also, if a voltage changeover block is fitted, check that changeover links make good contact. Open switch (see Correction 1) and replace suppressor capacitor (10,000pF + 80% - 20%, 1500 V.D.C.).
N. Automatic Switch. Fails to switch off when last record has played or switches off without playing.	1. Record overarm (65) not free. 2. Switch-off lever on lower casting stiff or bent. 3. Operating control lever (142) jammed.	Check that overarm falls freely, and make sure that rubber sleeve is against overarm casting. Remove spring clip (199), washer (198) and spring (197) to withdraw overarm and lightly oil its spindle, if necessary. With overarm inward in operating position and no records on spindle (61) check that end of overarm is not more than $\frac{3}{16}$ " below spindle step. Overarm should not tilt record stack. Reshape or replace overarm, as necessary. Check that it moves freely and returns under control of its spring. Lightly grease between lever and unit plate if necessary. If tail of lever is bent out of square, reshape it. See Fault J, correction 2.

PRINTED IN ENGLAND

73625

Issue 2

Garrard
A PLESSEY QUALITY PRODUCT

