

MANUAL  
*for the*  
GARRARD MODEL 301  
TRANSCRIPTION  
MOTOR



THE GARRARD ENGINEERING AND MANUFACTURING COMPANY LIMITED  
SWINDON : ENGLAND

**FIRST EDITION 1954**  
**SECOND EDITION 1956**

# *Introduction*

**A**S the owner of this Garrard Model 301 Transcription Motor you have a unit whose performance is supreme in its class and this manual has been prepared to enable you to enjoy and maintain the high performance which this motor can achieve.

Should you require any further information or advice not covered by this manual, please do not hesitate to ask your nearest Garrard agent or write to our Technical Service Department, Newcastle Street, Swindon, who will be pleased to help you.

# Index

	<i>page</i>
DESCRIPTION . . . . .	7
OPERATING INSTRUCTIONS - . .	8
TECHNICAL DETAILS - - . .	11
MAINTENANCE - - - .	12
INSTALLATION INSTRUCTIONS .	13
SERVICE ADJUSTMENTS . . .	17
SPARES LIST . . . . .	19

This Manual is supplied with Motor number . *16321*

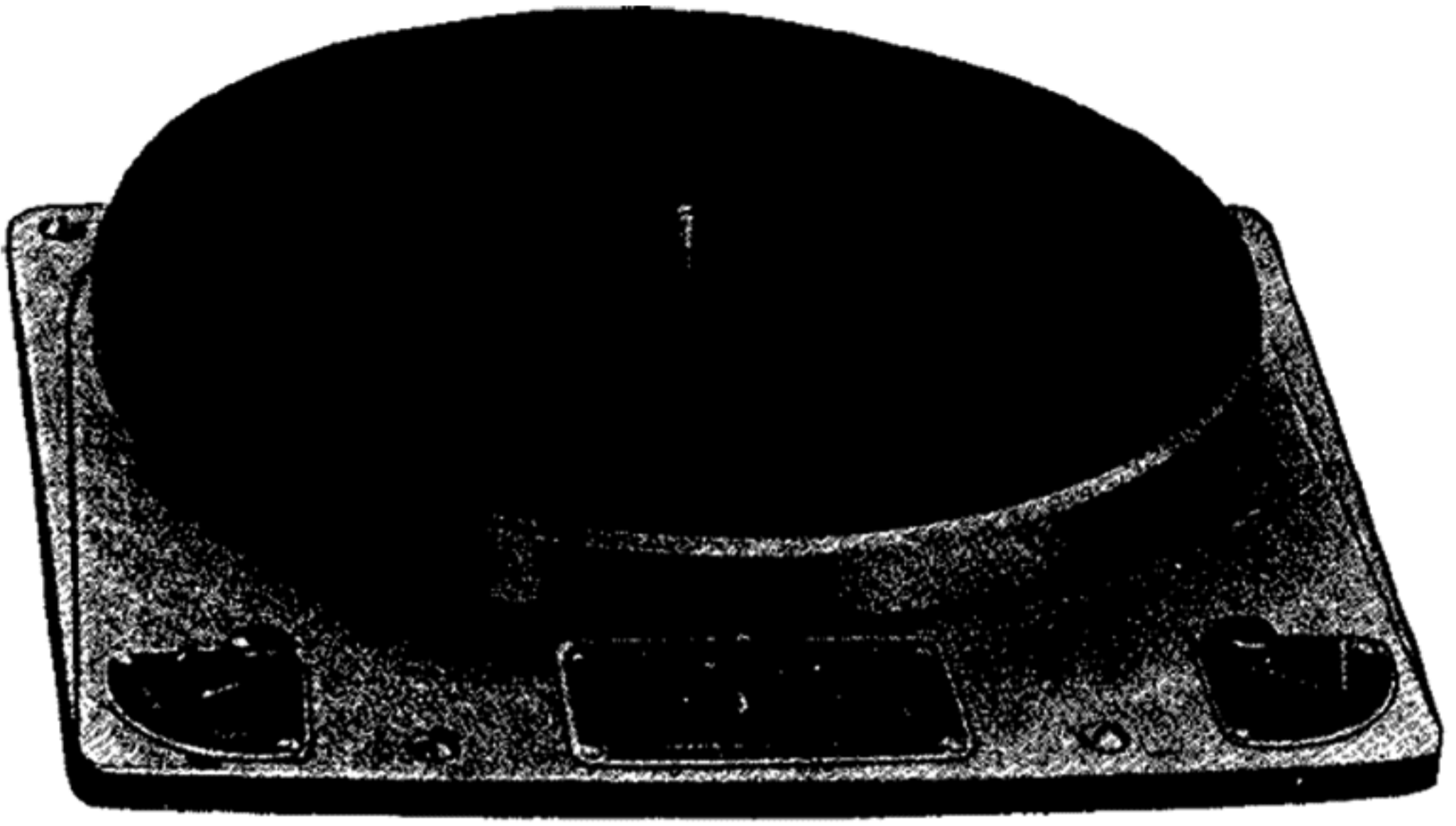

THE GARRARD MODEL 301 TRANSCRIPTION MOTOR

## *Description*

**T**HE Garrard Model 301 Transcription Motor is the culmination of 36 years experience in the design and manufacture of high quality gramophone equipment, and this motor has been designed to provide the professional user and quality enthusiast with a unit supreme in its class.

The Model 301 Transcription Motor has three controls, the speed range knob on the right hand side, speed adjusting control in the centre and the on-off knob on the left hand side.

It has extremely low wow and flutter content. rumble being almost non existent. Each of the three speeds is adjustable by means of a knob which operates a specially designed eddy current brake to enable the precise speed to be obtained.

Great attention has been given to details appreciated by the connoisseur, such as a suppressor condenser to avoid switch clicks, a heavy turntable diecast in aluminium and accurately balanced, a robust hardened and super finished turntable spindle pressure grease lubricated, a fully retracting intermediate wheel and a brake to reduce the free revolutions of the turntable on switching off.

The unit is supplied complete with stroboscope, record adaptor for 7" large hole records and clip, a tube of special high pressure grease, all fixing screws, set of spring suspensions, template, manual, and test report.

# Operation

To operate the Garrard Model 301 Transcription Motor proceed as follows:—

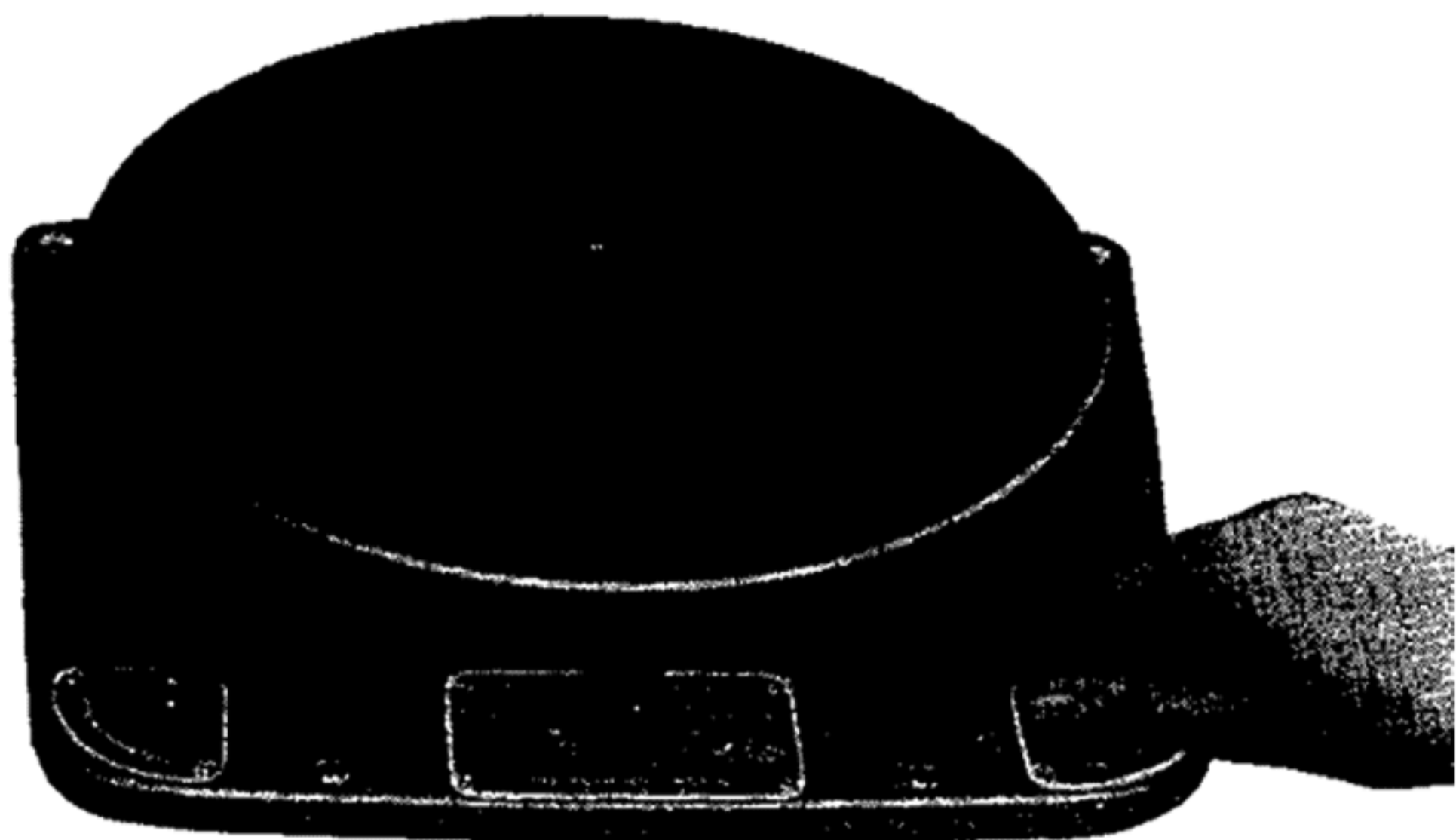

**(1) Move speed range knob to desired speed**

Diagram 1



**(2) Place record on turntable**

Diagram 2



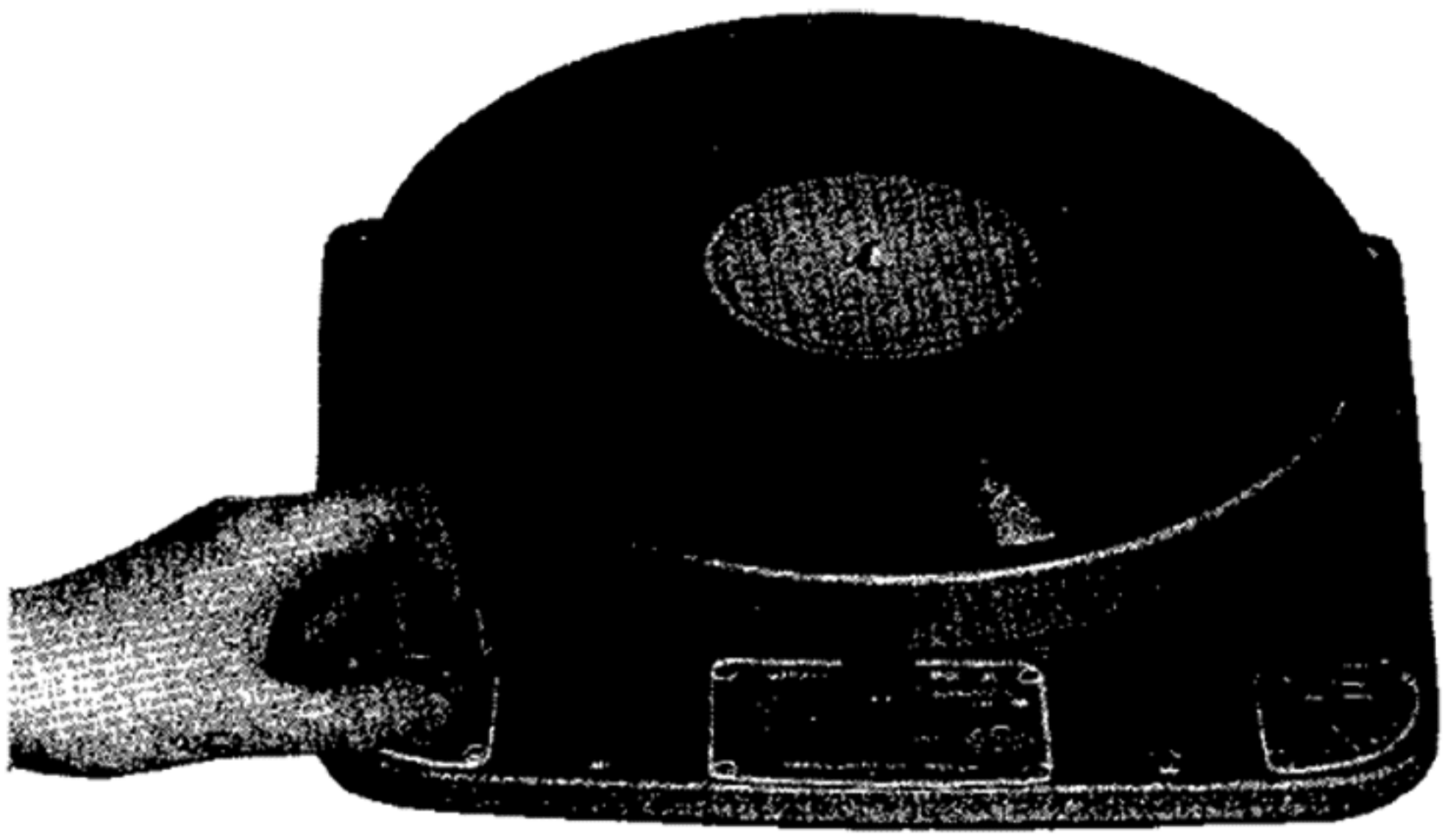

(3) Switch on

Diagram 3

To set speed place a record on the turntable and then place the stroboscope on the record. Start motor. Place pickup on record and turn the speed adjusting knob until the ring of dots applying to that speed for which you are setting appear to remain stationary when illuminated under an appropriate A.C. light source, Diagram 4.

For highly accurate transcription work where the slightest speed deviation is critical it is desirable to let the motor run for approximately 10 minutes so that it may reach its normal working temperature. For such critical work, speed should be re-checked on changing the speed range.



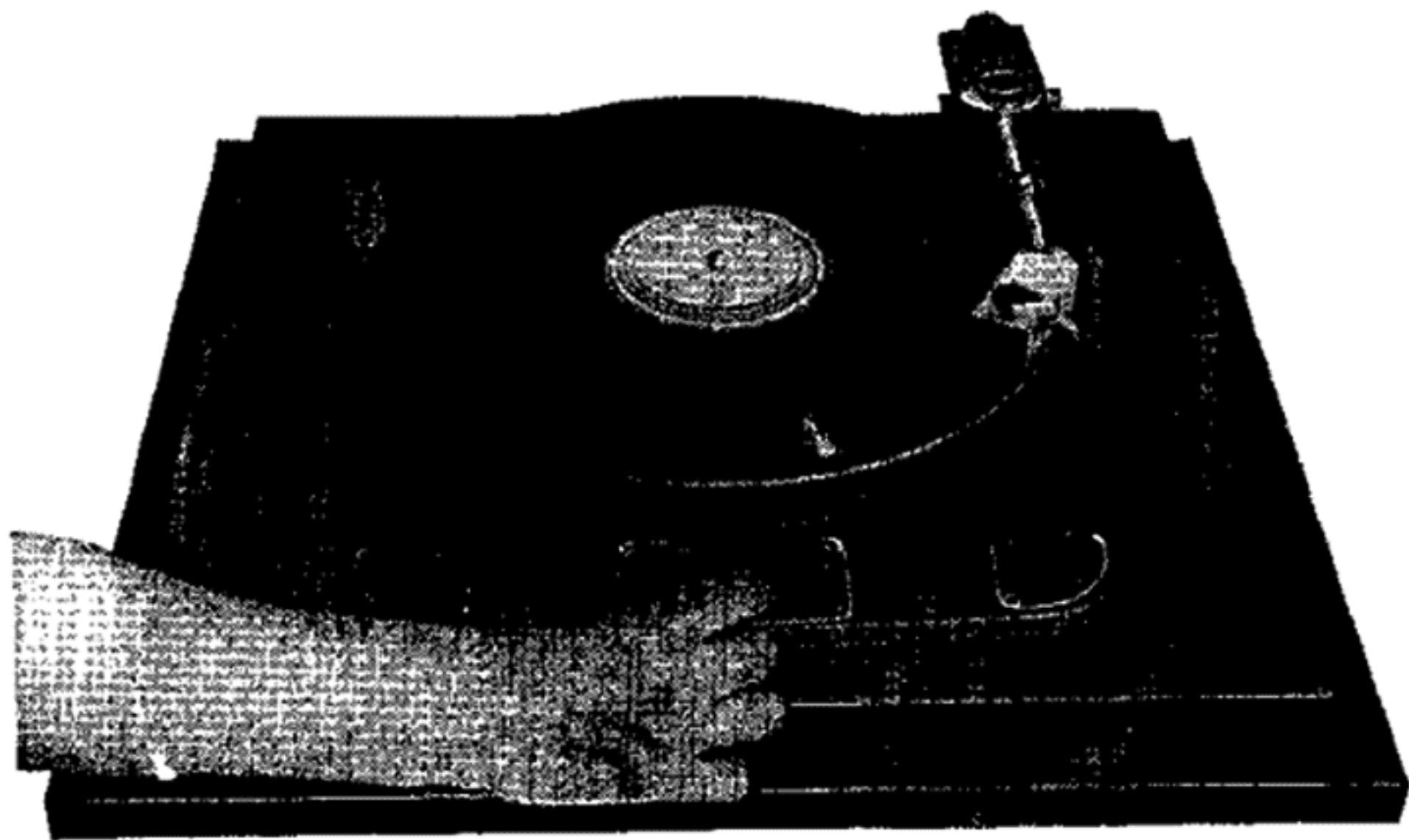

Diagram 4

To protect the intermediate wheel from damage the speed change knob is interlocked with the on-off knob. To change the speed range the motor must be switched off by means of the no-off knob.

The turntable must not be held stationary with the motor switched on and the on-off switch on the motor should always be used for stopping.

# Technical Details

- Turntable** - Diecast Aluminium 12" diameter machined all over and accurately balanced.  
Weight 6 lbs. Fitted with rubber mat.  
A three speed stroboscopically engraved turntable is available at extra cost.
- Unit Plate** - Diecast Aluminium.
- Motor** - Shaded pole induction in heavy cast casing suspended on six tensioned springs. Magnetically screened.
- Voltage** - Dual Range 100 to 130 and 200 to 250 volts.
- Frequency** - 50 or 60 cycles according to motor pulley fitted. Alternative pulley available.
- Consumption** - 16 watts maximum.
- Wow** - Less than 0.2%.
- Flutter** - Less than 0.05%.
- Rumble** - Almost non existent.
- Speed Range** - 32 to 34, 44 to 46 and 76 to 80 r.p.m. approx.
- Finish** - High quality grey tone or broken white enamel with black accessories.
- Size** - Motor Unit  $14\frac{1}{2}$ " back to front,  $13\frac{3}{4}$ " wide  
 $2\frac{1}{4}$ " above and  $3\frac{1}{2}$ " below under surface of unit plate. Recommended size for motor board 18" x 18".
- Weight** - Nett. 16 lbs. Gross 20 lbs.

**Instrumentation:—**  
Gaumont-Kalee Wow and Flutter Meter Type 564.  
3,000 cycle constant frequency records at  $33\frac{1}{2}$ , 45 and 78 r.p.m.

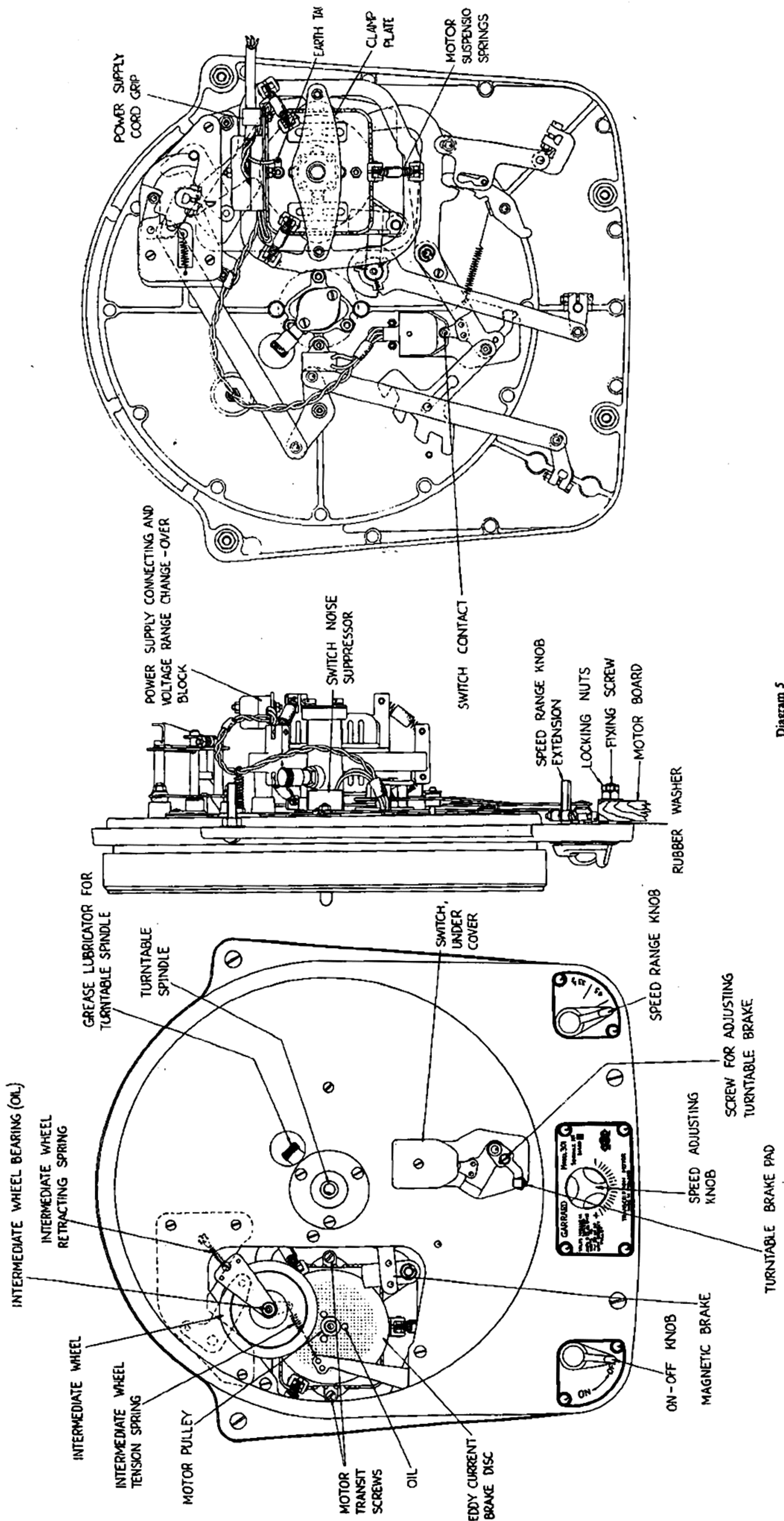

Diagram 5



# Maintenance

The turntable spindle is pressure grease lubricated by means of a screw down grease lubricator in the side of the turntable spindle housing. Diagram 5. An occasional turn of the cap of this lubricator is all that is required to ensure adequate lubrication of the top and bottom bearings also the thrust pad. When after a period of use the cap has been screwed right down it should be unscrewed and refilled with the special grease supplied with the unit.

The motor and intermediate wheel bearings being of the oil retaining type rarely need lubricating. When however the need for oil is apparent remove the turntable and sparingly lubricate these bearings afterwards removing all surplus oil and making sure that no oil is present on the motor pulley or intermediate wheel before replacing the turntable.

These oiling points are indicated on Diagram 5, the oil recess in the top motor bearing being accessible through one of the three holes in the aluminium disc of the eddy current brake.

The motor must be in the switched off position before removing or replacing the turntable. The turntable is an accurate taper fit on its spindle and if difficulty is experienced in removing it the spindle top should be given a sharp downward tap with a small block of wood while the turntable is lifted.

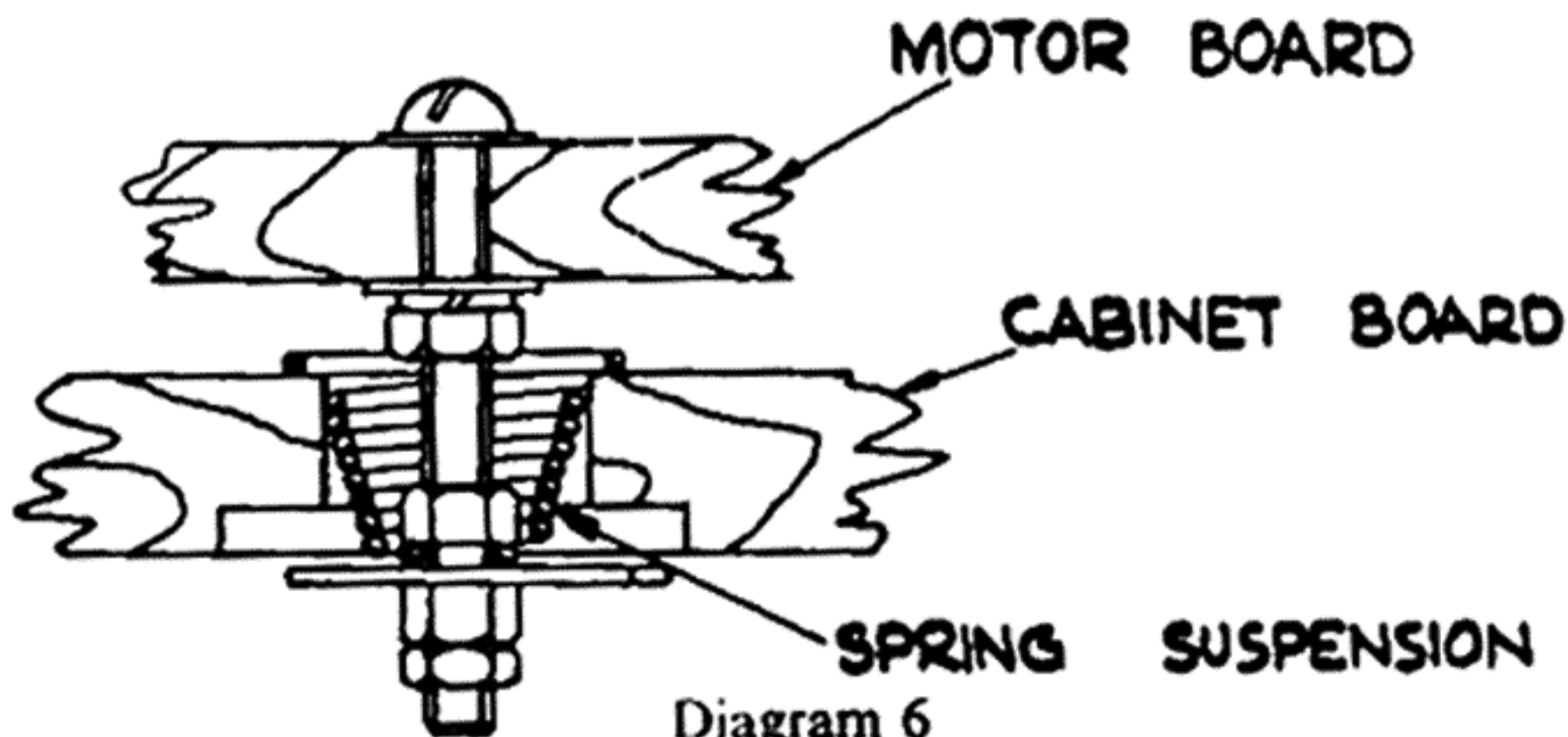

# *Installation*

The Garrard Model 301 Transcription Motor should be assembled to a substantial wooden motor board which should be cut out and drilled to the template supplied with each unit or to the dimensions given on Diagram 11. The motor should be assembled to the board, using the rubber washers supplied, between the unit plate and the board to prevent any distortion of the plate due to any possible inaccuracies in the board.

Insert the screws and assemble the washers and nuts as indicated in Diagram 5 tightening up the nuts equally a little at a time, then securely tightening up the lock nuts.

**To protect the electric motor during transit it is firmly clamped by means of two transit screws, Diagram 5.**

These screws, the heads of which are coloured red, must be unscrewed as far as they will go to release the motor clamp plate which allows the motor to float freely on its suspension springs. To clamp the motor for transit purposes the two motor transit screws should be tightened up.

The pickup to be used should be mounted on the board according to the manufacturers' instructions.

To prevent any extraneous vibrations reaching the motor and pickup, it is recommended that the wooden motor board carrying this assembly be spring mounted in the cabinet as illustrated on Diagram 7, the cabinet board being as shown in Diagram 8. With the motor and turntable in position there should be a gap of about  $\frac{3}{16}$ " to  $\frac{1}{4}$ " between the two boards. A reduced dimensioned template for this board is given in diagram 12.

On final installation the motor should be levelled by adjusting the inner nuts of the spring suspensions, removing the lower nut and lock nut to do so, replacing them when the unit is level.

The level should be checked by means of a spirit level placed on a record on the turntable.

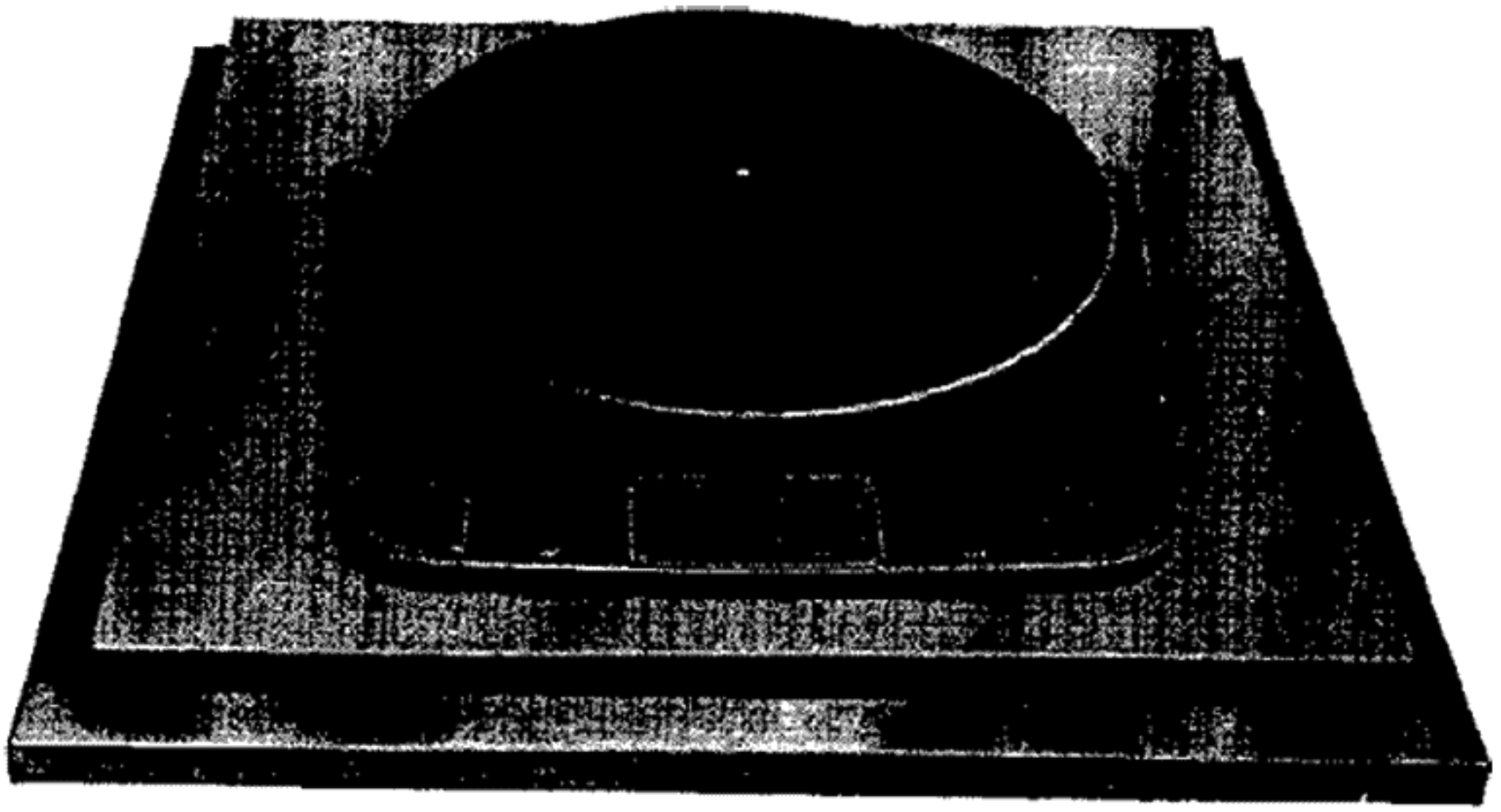

Diagram 7

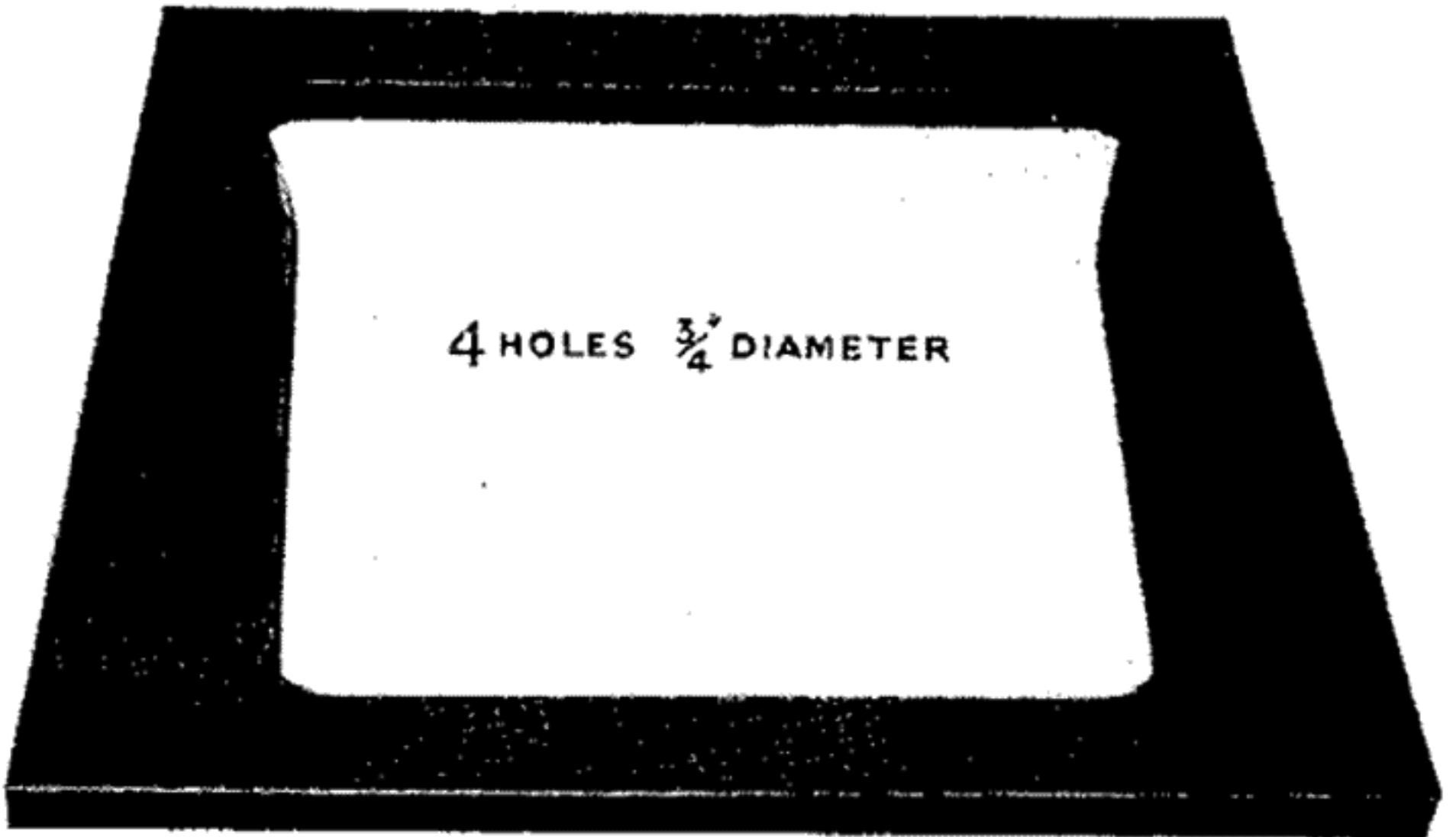
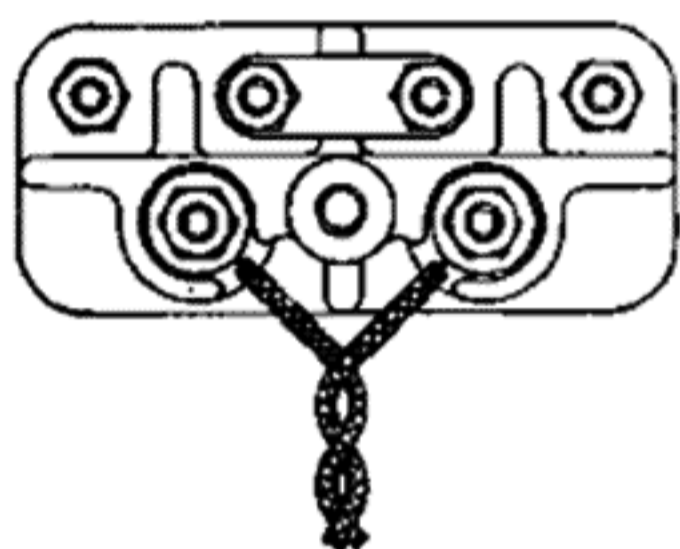

Diagram 8



A suitable set of four spring mounting assemblies are supplied with each transcription motor and they should be assembled as shown on Diagram 6.

Before assembling the motor into the cabinet connect the power supply lead, if not already fitted, to the power supply terminal block situated at rear of motor, making sure that the lead is securely clamped in the cord grip adjacent to the block. To open the cord grip remove the top clamp by sliding it sideways; then, after placing cord in position, press clamp over it, when it will click into position. Check that the voltage range is set correctly for the power supply to be used; the links should be set as shown on terminal block cover, and Diagrams 9 and



Set for 200/250 volts  
Diagram 9

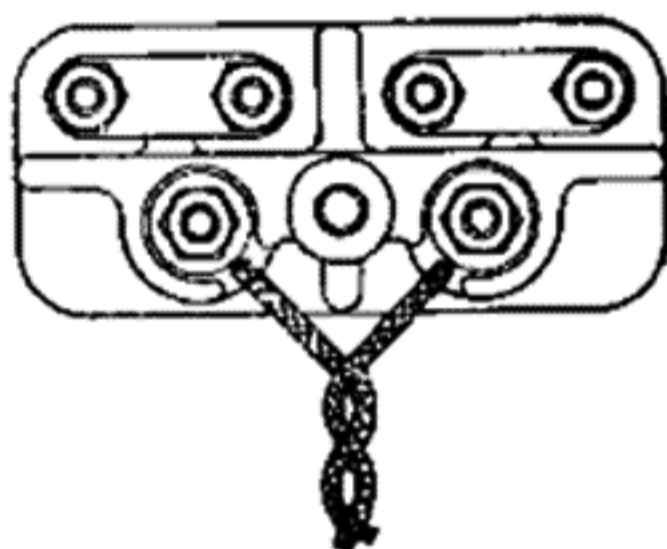

Set for 100/130 volts  
Diagram 10

10. The motor pulley should also be checked to see that the correct one for the frequency of the power supply is in position on the motor, a nickel finished one for 50 cycles, a brass one for 60 cycles.

Should the motor pulley require changing, remove the pulley on the motor by loosening the two grub screws holding it to the shaft and on fitting the other pulley check that it is in its correct position before tightening the screws, by moving the intermediate wheel inward, making sure that the rubber tyre runs in the centre of the appropriate step and its side face is clear of the pulley step face by  $\frac{1}{32}$ " when set on  $33\frac{1}{3}$  or 45 r.p.m.



The motor should be earthed by connecting a lead from the earthing tag on the motor, Diagram 5, to a good earth connection. For preference three core power supply lead should be used, two connections being made to the power supply terminals and the other to the motor earthing tag.

On final installation it is essential that the leads from the motor are not strained tight but should be very loosely looped so that the motor remains freely suspended on its springs.

The shaft of the speed range knob is extended so that a standard wafer switch may be fitted if required.

## *Service Adjustments*

The Garrard Model 301 Transcription Motor has been designed to give reliable service with continuous use and these instructions have been included to enable the user to make the few minor adjustments which may become necessary after long periods of use in order to maintain the high standard of performance which this motor is capable of producing.

### **Intermediate Wheel.**

The accuracy of the rubber tyred intermediate wheel is of supreme importance in maintaining the high standard of performance of the unit and should any wow or flutter be suspected check the intermediate wheel after first making sure the record is not at fault. Flutter or bump in the reproduction may be caused by flats on the intermediate wheel. These may result from the turntable being held stationary with the motor switched on, for this reason the turntable must never be stopped with the hand, but the unit switched off by means of the on-off switch on the unit plate. Should the intermediate wheel become damaged it should be replaced with a new one.

Flutter and wow can also be caused by the side face of the rubber tyre on the intermediate wheel rubbing on the side of one of the motor pulley steps, the position of the pulley on the motor shaft should be such that there is  $\frac{1}{32}$ " clearance between the side faces of the intermediate wheel and motor pulley steps. Wow can be caused by oil or grease on the motor pulley, intermediate wheel tyre or the driving surface of the turntable. In this case thoroughly clean all driving surfaces with a clean rag.

Should hum, originating from the motor, be suspected, see that the motor is freely suspended on its springs and that the motor transit fixing screws Diagram 5 have been removed. Also see that the power supply and earth leads are slack and not straining the motor on

its springs, these leads, if too rigid, will transmit the motor vibration to the cabinet and so be reproduced.

Should the motor fail to start on switching on, first make sure that the power supply is reaching the terminals in the terminal block. If found to be correct switch off at the power supply then check that the nuts holding the voltage range change over links are tight, also remove the switch cover and check that the switch contact moves each of the two switch blades as it moves between them when switching on. The switch blades and the contact should be thoroughly cleaned and a faint trace of vaseline placed on each of the two blades before replacing the cover.

Should the motor still fail to start check the circuit of the coils. The total resistance should be 460 ohms if set on the 200 to 250 volt range or 115 ohms on the 100 to 130 volt range.

If the turntable continues to revolve for several revolutions after switching off by means of the switch on the unit, the turntable brake pad probably needs adjusting. To make this adjustment, remove the turntable as described on page 12, loosen the turntable brake adjusting screw, Diagram 5, move the brake a small amount outward toward the rim and retighten the screw. Make sure that the brake is not set too far out because it can prevent the switch breaking contact if so set.

# Spare Parts List

No. on Diagram	Drawing No.	Name of Part
1	A.51397	Turntable Spindle.
2	A.40151	Screw.
3	A.51799	Housing with Bearings A.51889.
4	A.51803	Greaser with Cap A.51803A.
5	A.51888	Circlip.
6 } 7 }	A.52493	Thrust Pad Assembly.
8	A.52075	Gasket.
9	A.51802	Thrust Plate.
14	A.42501	Spring Washers.
15	A.40132	Screw.
16	A.40458	Screw.
17	A.40085	Screw.
18	A.40254	Screw.
19	C.51447	Motor Plate with Speed Plate. A.51370, On-Off Plate A.51371. Name Plate A.51372 and Rivets A.42009. (State colour).
20	A.51779	Stop Pin.
21	A.51778	Pivot Pin.
22	A.40768	Rubber Washer.
23	A.40678	Washer.
24	A.41058	Nut.
25	A.41061	Nut.
26	A.41737	Spring Clip.
27	A.42520	Spring Washer.
28	A.41006	Nut.
29	A.51814	Knob.
30	A.51813	Spindle.
31	B.51424	Control Knob Speed Change.
32	B.51206A	Control Knob On-Off.
33	A.42539	Friction Spring.
34	A.42144	Rivet.
35	A.40514	Washer.



## *Spare Parts List—continued*

No. on Diagram	Drawing No.	Name of Part
36	A.51854	Pad Spring with Brake Pad A.45064 and Spring Clip A.41722.
37	A.40055	Screw.
38	A.40519	Washer.
39	A.50448	Collar.
40	A.51856	Catch Lever.
41	A.40643	Washer.
42	A.42042	Rivet.
43	A.51851	Brake Lever Assembly.
44	A.52004	Interlocking Lever Assembly.
45	A.41695	Spring fixing to items 40 and 43.
46	A.40519	Washer.
47	A.42503	Spring Washer.
48	A.40014	Screw.
49	A.51847	Switch Lever.
50	A.42006	Rivet.
51	A.50448	Collar.
52	A.51850	On-Off Lever.
53	A.51849	Link for Switch Lever.
54	A.40018	Screw.
55	A.45210	Collar.
56	A.51843	Intermediate Lever.
57	A.51844	Speed Change Lever.
58	A.42006	Rivet.
59	A.51841	Link 'A'.
60	A.47594	Collar.
61	A.40560	Washer.
62	A.41012	Nut.
63	A.51840	Link 'B'.
64	A.51837	Index Lever Assembly with Pin A.43303.
65	A.51836	Spindle.
66	A.51886	Collars.
67	A.43101	Grommet.
68	A.40051	Screw.

## *Spare Parts List—continued*

No. on Diagram	Drawing No.	Name of Part
69	A.43031	Tag.
70	A.51815	Mounting Plate Assembly.
71	A.40627	Washers.
72	A.40105	Screw.
73	A.42503	Spring Washer.
74	A.51831	Top Plate Assembly.
75	A.51858	Intermediate Wheel Assembly.
76	A.41688	Spring, fixing to items 49 and 77.
77	B.51827	Support Bracket Assembly.
78	A.41670	Spring, fixing to items 69 and 77.
79	B.51825	Support Lever with Pin A.51826.
80	A.43319	Pin.
81	A.51823	Lifting Spindle Assembly.
82	A.51820	Spring Lever Assembly.
83	A.41639	Spring, fixing to items 82 and 86.
84	A.40501	Washer.
85	A.40182	Screw.
86	A.51818	Mounting Plate.
87	B.51834	Lifting Cam.
88	C.51380	Turntable Mat.
89	C.51793	Turntable (State Colour).
	C.53241	Turntable Stroboscopically Engraved for 50 cycles.
	C.53475	Turntable Stroboscopically Engraved for 60 cycles.
90	A.51863	Pulley for Motor 50 cycles. (Nickel finish.)
	A.51864	Pulley for Motor 60 cycles. (Brass finish.)
91	A.40267	Screw.
92	A.51894	Speed Disc.
93	A.43300	Split Pin.
94	A.40503	Washer.
95	A.41693	Friction Spring.
96	A.42043	Rivet.
97	A.51880	Bearing Cover.

No. on Diagram	Drawing No.	Name of Part
98	A.41721	Spring.
99	A.43526	Rotor Bearing.
100	A.40730	Felt Washer.
101	A.51806	Spring Pin.
102	B.51882	Top Motor Cover with Pivot Pin A.51885.
103	A.42068	Rivet.
104	A.51809	Centre Plate.
105	A.51812	Link.
106	A.41720	Spring.
107	A.51807	Magnet Assembly less Washer, Collars and Rivet.
108	A.51811	Brake Operating Lever.
109	A.40460	Stud.
110	A.51870	Rotor Spindle Assembly.
111	B.51869	Stator Assembly.
112	A.40070	Screws.
113	A.41700	Top Spring.
114	A.45120	Rubber Sleeves.
115	A.41701	Bottom Spring.
116	C.51419	Yoke.
117	B.51879	Bottom Motor Cover.
118	A.43000	Earthing Tag.
120	A.43210	Thrust Ball.
121	A.51883A	Bottom Bearing Cover.
123	A.52641	Switch Suppressor Unit.
124	A.52663	Switch Lead Assembly.
125	A.41686	Contact Spring.
126	A.41008	Nut.
128	A.51322	Switch Block.
129	A.40130	Screw.
130	A.51327	Cover for Switch Block.



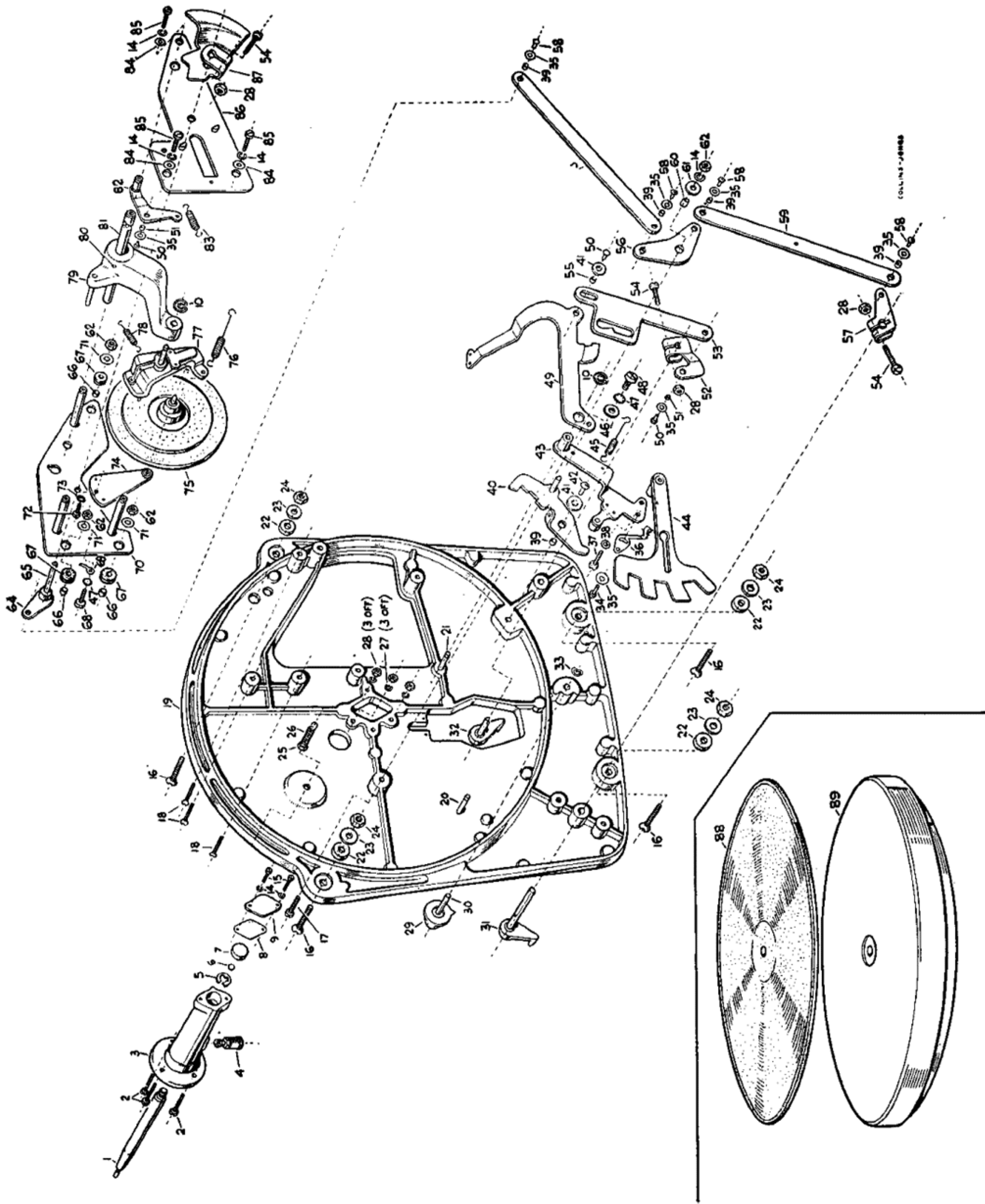

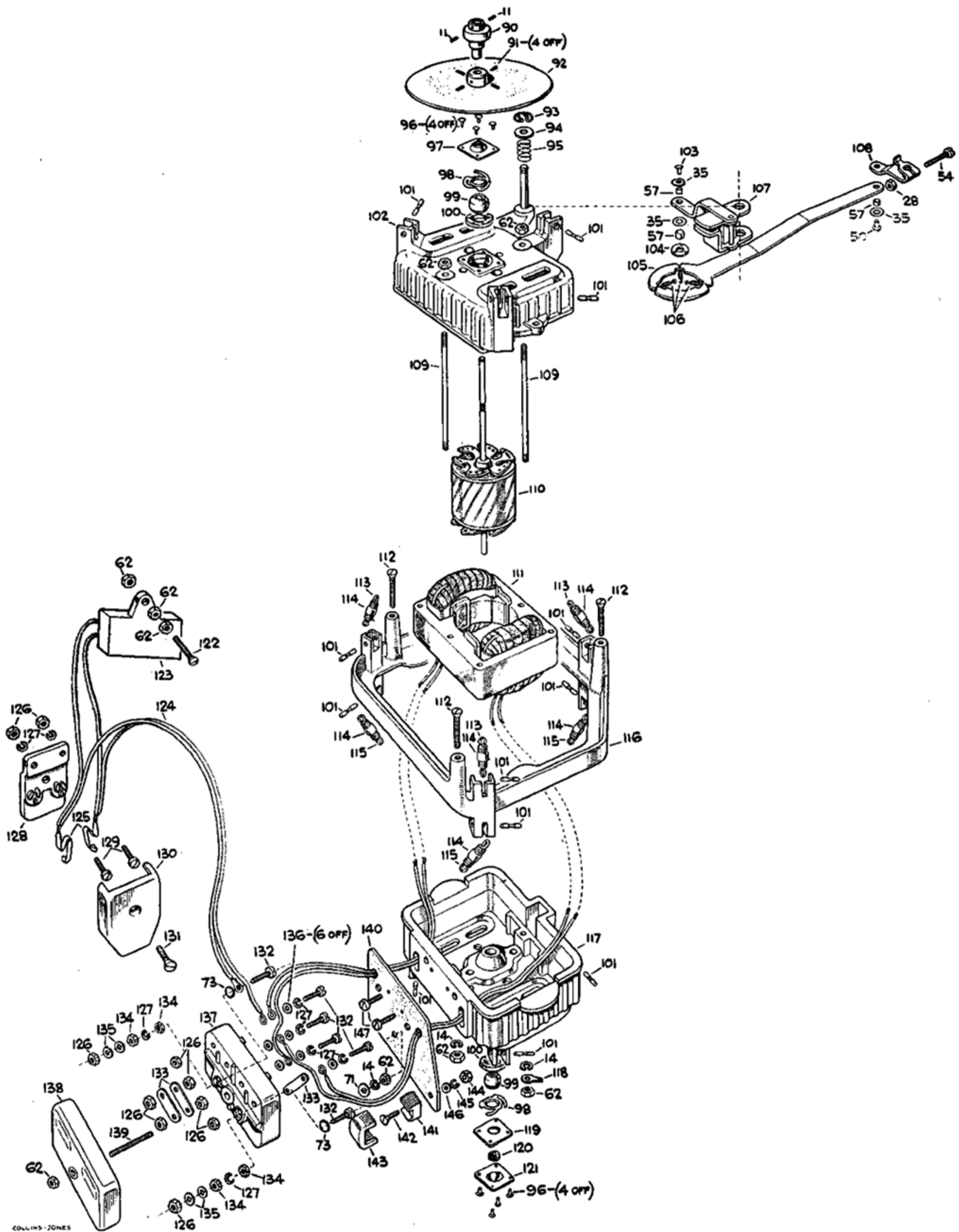

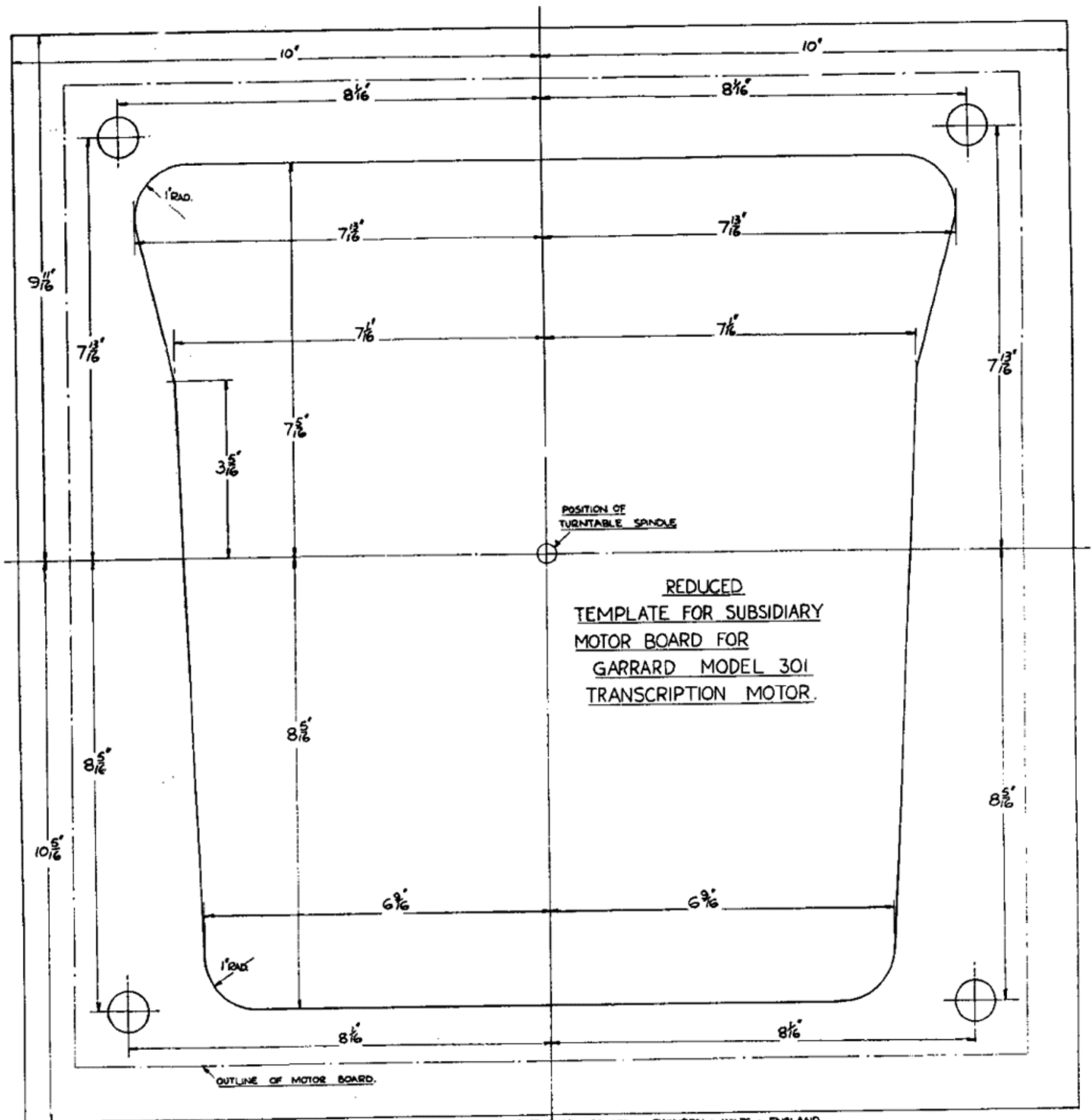

REDUCED DIAGRAM OF  
TEMPLATE FOR 'GARRARD' MODEL 301  
TRANSCRIPTION MOTOR

OUTLINE OF HOLE IN MOTOR BOARD

OUTLINE OF UNIT PLATE

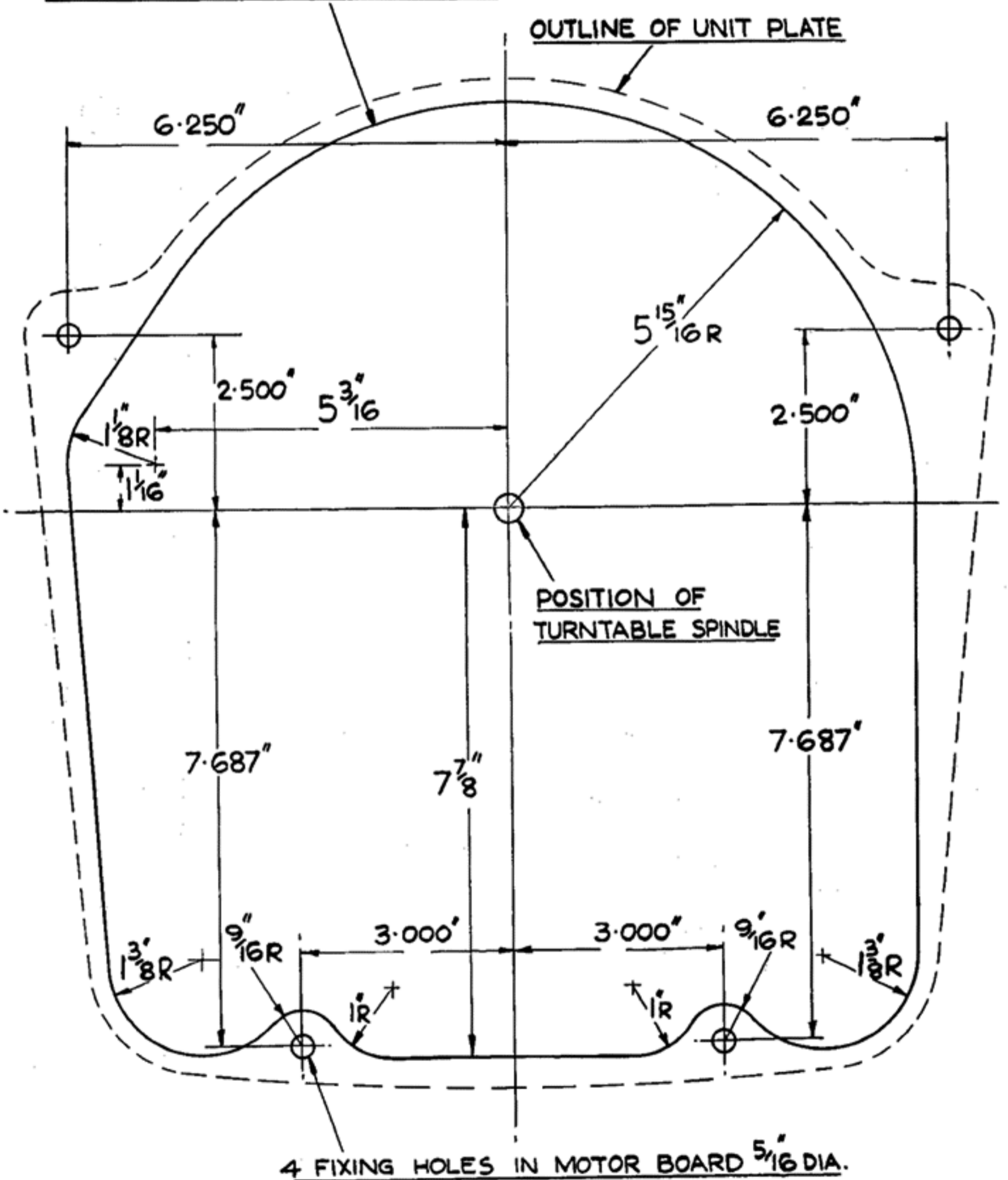

4 FIXING HOLES IN MOTOR BOARD  $5 \frac{1}{16}$  DIA.

Diagram 11

