

Garrard

Spare parts list and exploded view for DD131 and DD132 direct drive turntables

For Service Manuals Contact
MAURITRON TECHNICAL SERVICES
8 Cherry Tree Rd, Chinnor
Oxon OX9 4QY
Tel:- 01844-351694 Fax:- 01844-352554
Email:- enquiries@mauritron.co.uk

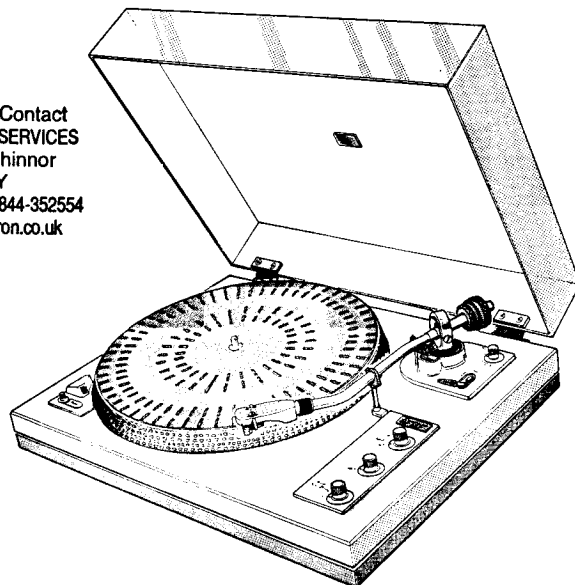

TO BE USED
WITH THE
GTS
SERVICE
MANUAL

3675

Notes:

When ordering spare parts please quote 'DD131' or 'DD132', the 8-figure code no. on the coloured inspection label and part no., as well as colour and operating voltage when applicable. Items are common to both units, unless otherwise specified. Reference numbers are those used on the exploded view overleaf.

Ref. No.	Garrard Part No.	Description	Ref. No.	Garrard Part No.	Description
1	606/2/80105/001	Rubber foot	21	999/4/00411/052	Screw (2)
2	606/1/80917/001	Cover, with hinges	22		Not used
3	999/4/31019/001	Screw (4)	23	606/7/80073/001	Control knob
4	606/7/80199/001	Clamp plate (2)	24	606/7/81191/003	Pickup arm trim
5		Screw (M2.5), length to suit cartridge (2)	25	606/2/80156/001	Adjusting screw
6	606/1/80570/100	Type H1 pickup head shell (pearl grey)	26	606/1/80207/001	Cueing lifter
	606/1/80570/200	Type H1 pickup headshell (black)	27	999/4/30979/002	Screw (2)
	606/1/80627/002	Type H1 pickup head shell (pearl grey) with cartridge fixing kit	28	606/2/80124/001	Cueing plate
	606/1/80627/003	Type H1 pickup head shell (black) with cartridge fixing kit	29	606/1/80240/001	Cueing lever
7	606/2/41235/002	Washer for head shell (2)	30		Not used
8		Not used	31	999/4/31029/017	Screw
9	606/1/80237/001	Pickup arm sleeve, with grip ring and leads	32	606/2/80688/001	Friction pad
10	606/1/81166/001	Pickup arm tube, with leads and gimbal (silver)	33	606/1/80241/001	Cueing system, with lifter and lever
	606/1/81166/002	Pickup arm tube, with leads and gimbal (black)	34	606/7/67055/001	Spring
	606/1/81631/001	Pickup arm tube, with leads (silver)	35	606/2/80256/001	Nut
	606/1/81631/002	Pickup arm tube, with leads (black)	36	606/1/81205/001	Pickup lead (DIN plug) with outlet plate and tag strip
11	606/7/80174/001	Hinge (2)		606/7/81092/001	Pickup lead only (DIN plug)
12	606/7/80193/001	Pivot screw	37	606/1/81206/001	Phono lead (RCA type plugs) with outlet plate and tag strip
13	606/1/80468/001	Gimbal, with support and restrictor		606/7/81091/001	Phono lead only (RCA type plugs)
14	606/7/81183/001	Retainer	38	606/2/80500/012	Graphics trim (DD131)
15	606/1/81153/001	Counterbalance weight		606/2/80500/013	Graphics trim (DD132)
16	606/7/80194/001	Pivot screw	39	606/1/81357/002	Control trim with graphics trim (DD131)
17	606/2/80183/001	Restrictor screw		606/1/81357/003	Control trim with graphics trim (DD132)
18	999/4/31039/001	Screw (2)	40		Not used
19	999/4/01145/002	Screw	41	606/7/80091/001	Bias cam
20	606/2/80204/001	Gimbal support	42	606/7/67043/001	Spring

continued overleaf

Garrard Sales Service Department,
Newcastle Street,
Swindon, SN1 2LH, Wiltshire.
Telephone: Swindon (0793) 35381
Telex: 44271.

In U.S.A.:
Plessey Consumer Products,
Garrard Dealer Sales Division,
100 Commercial Street,
Plainview, New York 11803.
Telephone: (516) 938 8900.

Ref. No.	Garrard Part No.	Description	Ref. No.	Garrard Part No.	Description
43		Not used	133	999/4/30979/006	Screw (2)
44	606/7/80092/001	Bias cam follower	134	606/7/79977/001	Impulse link
45	999/4/00431/046	Spring clip (2)	135	999/4/30976/002	Screw
46	606/7/80203/001	Bias lever	136	999/4/30979/008	Screw (2)
47	606/1/80474/001	Bias plate, with lever, cam and follower	137	999/4/00431/002	Spring clip
48	606/4/42561	Bowed washer	138	606/7/80400/001	Trip pawl
49	606/2/41234/002	Washer	139	606/7/80399/001	Trip friction lever
50		Not used	140		Not used
51	999/4/31029/017	Screw (2)	141		Not used
52	999/4/01515/020	Screw	142		Not used
53	999/4/01167/004	Spring clip	143	606/7/44668/001	Spring
54	606/2/78476/001	Nut (2)	144	606/1/81114/001	Main cam, with lever and pawl
55	606/1/79982/001	Overload casting, with screws	145	606/1/78742/001	Pinion spindle with clip
56	991/4/01665/039	Screw (2)	146	606/1/79793/001	Pinion moulding
57	606/4/44448/001	Overload spring	147	606/2/41234/002	Washer (2)
58	606/2/81123/001	Vertical pivot support	148	999/4/31003/001	Fastener (2)
59	606/1/81121/001	Pickup spindle	149		Not used
60		Not used	150		Not used
61	606/1/80467/001	Pickup lever, with overload casting	151		Not used
62	606/2/80163/001	Collar	152	999/4/30979/002	Screw
63	606/2/80143/001	Nut	153	999/4/31029/036	Screw (4)
64	606/1/80472/001	Selector actuating lever with link (DD132)	154	606/7/78675/001	Lower bearing
65	606/7/80191/001	Size selector link (DD132)	155	606/7/43217/001	Ball
66	606/2/41218/068	Washer (3) (DD132)	156	606/7/44644/001	Spring
67	999/4/30993/002	Fastener (DD132)	157	606/7/80662/001	Programme lever
68	606/4/79526/001	Spring clip (DD132)	158	606/1/81146/001	Modular mechanism, complete, with pickup lever
69	606/4/79526/001	Spring clip	159	999/4/00687/006	Spring clip
70		Not used	160	606/2/41218/055	Washer
71	606/2/41234/003	Washer	161	606/7/44690/001	Spring
72	999/4/31029/047	Screw (8)	162	606/2/80719/001	Roller
73		Not used	163	606/7/67048/001	Wire clip
74		Not used	164	606/1/81115/001	Cam lever, with roller
75		Not used	165	606/4/67050/001	Spring
76	999/4/30979/001	Screw	166	606/7/81116/001	Index lever
77	606/7/79879/001	Lifting blade	167	999/4/02654/001	Spring clip
78		Not used	168	606/7/78973/002	Drive belt
79	999/4/30979/002	Screw	169	999/4/31029/021	Screw
80		Not used	170		Not used
81	606/7/78672/001	Selector lever	171	606/1/79983/001	Support plate
82	606/2/79724/001	Inter-selector lever	172	408/4/51881/001	Microswitch (2)
83	999/4/00431/002	Spring clip	173	999/4/30979/001	Screw (DD131)
84	606/4/79526/001	Spring clip (3)	174	501/1/61530/001	Low tension loom with microswitches
85	606/7/80101/001	Switch lever (3)	175	606/1/80217/007	Control plate, with programme actuating and switch levers (DD131)
86		Not used		606/1/80217/004	Control plate, with programme actuating and switch levers (DD132)
87	606/7/80171/001	Ball	176	606/2/81377/001	Spacer
88	606/7/44644/001	Spring	177	999/4/31029/017	Screw (3)
89	606/1/80222/001	Control moulding (3)	178	606/1/81565/001	Power supply transformer
90	606/7/80093/001	Programme actuating lever	179	999/4/30993/004	Fastener
91	606/7/80073/001	Control knob (3)	180	991/4/01728/005	Nut (3)
92		Earth lead (part of 36 or 37)	181	999/4/00852/008	Shakeproof washer (3)
93	606/4/73057/001	Terminal strip	182	606/2/41234/003	Washer (3)
94		Outlet plate (part of 36 or 37)	183	606/7/80102/001	Grommet (2)
95		Rivet (part of 36 or 37)	184	606/2/41218/026	Washer (2)
96	999/4/31029/017	Screw	185	999/4/00432/007	Spring clip (2)
97	999/4/31029/017	Screw	186	606/2/72698/001	Adaptor for large hole records
98	999/4/00431/036	Spring clip	187	606/7/80098/001	Turntable mat
99	702/4/26564/001	'Heyco' bush	188	606/1/78251/069	Screw (3)
100		Not used	189	606/2/81145/001	Mat centre
101	606/7/80504/001	Cueing lever knob	190	606/2/81579/001	Turntable
102	606/7/80075/001	Cueing trim	191	606/2/81095/001	Turntable hub
103	606/1/80939/008	Mains lead with Europlug and strain relief plate	192	999/4/30979/030	Screw (3)
104	606/1/80939/009	Line cord with flat-pin plug (U.S.A.) and strain relief plate	193	606/7/81203/001	Cover
105	606/1/80939/007	Mains lead (U.K.) with strain relief plate	194	501/2/61563/002	Thrust plate (nylon)
106	606/7/67053/001	Spring	195	501/2/61563/001	Thrust plate (steel)
107	606/1/80229/001	Lifting platform with insert	196	606/1/80574/001	Pitch control knob
108	606/2/80086/001	Insert	197	999/4/30979/003	Screw (3)
109	606/2/80167/001	Screw	198	606/7/81168/002	Pitch control trim
110	991/02077/039	Screw	199	606/2/81665/001	Unit plate moulding
111		Not used	200		Not used
112	606/2/75392/001	Tilt wedge	201	999/4/02321/004	Flanged screw (6)
113	606/2/80696/001	Auxiliary weight	202	419/7/41514/001	Printed circuit board. See Note 1
114	991/4/02018/105	Screw (3)	203	999/4/31029/017	Screw (4)
115	606/2/41234/003	Washer (6)	204	702/1/26563/001	L.E.D. with lead
116		Pickup cartridge (please state type)	205	606/7/67066/001	Spring (4)
117	606/2/78480/001	Nut (2)	206	606/7/81102/001	Isolator foot (4)
118	501/2/61538/001	Mounting plate	207		Not used
119	606/2/81376/001	Spacer (3)	208	606/2/81103/001	Isolator foot bush (4)
120	501/1/61525/001	Garrard Type DDM2 direct drive motor complete with belt and mounting plate. See Note 1	209	999/4/31029/021	Screw (4)
121	501/1/60343/173	Earth lead	210		Not used
122	999/4/00852/022	Shakeproof washer	211	606/1/81167/001	Bottom cover (U.S./Canada)
123	999/4/30979/030	Screw		606/1/81167/002	Bottom cover (U.K./Europe)
124	702/4/26564/001	'Heyco' bush (black)			
	702/4/26574/001	'Heyco' bush (white)			
125	606/2/81085/002	Strain relief plate			
126	606/1/80233/001	Pickup rest			
127	999/4/31036/001	Lead clip			
128	999/4/30993/001	Fastener			
129	999/4/00852/008	Shakeproof washer			
130		Not used			
131	991/4/01911/004	Nut			
132	408/4/51883/001	Microswitch			

Note 1 The printed circuit board is 'trimmed' to match the electronic characteristics of each individual motor by means of a fixed resistor and pre-set potentiometers on the board. When ordering either a P.C.B., or a complete Type DDM 2 motor, please quote the colour of the mark (red, green or blue) on the motor casing near the point at which the flexible printed circuit strip emerges.

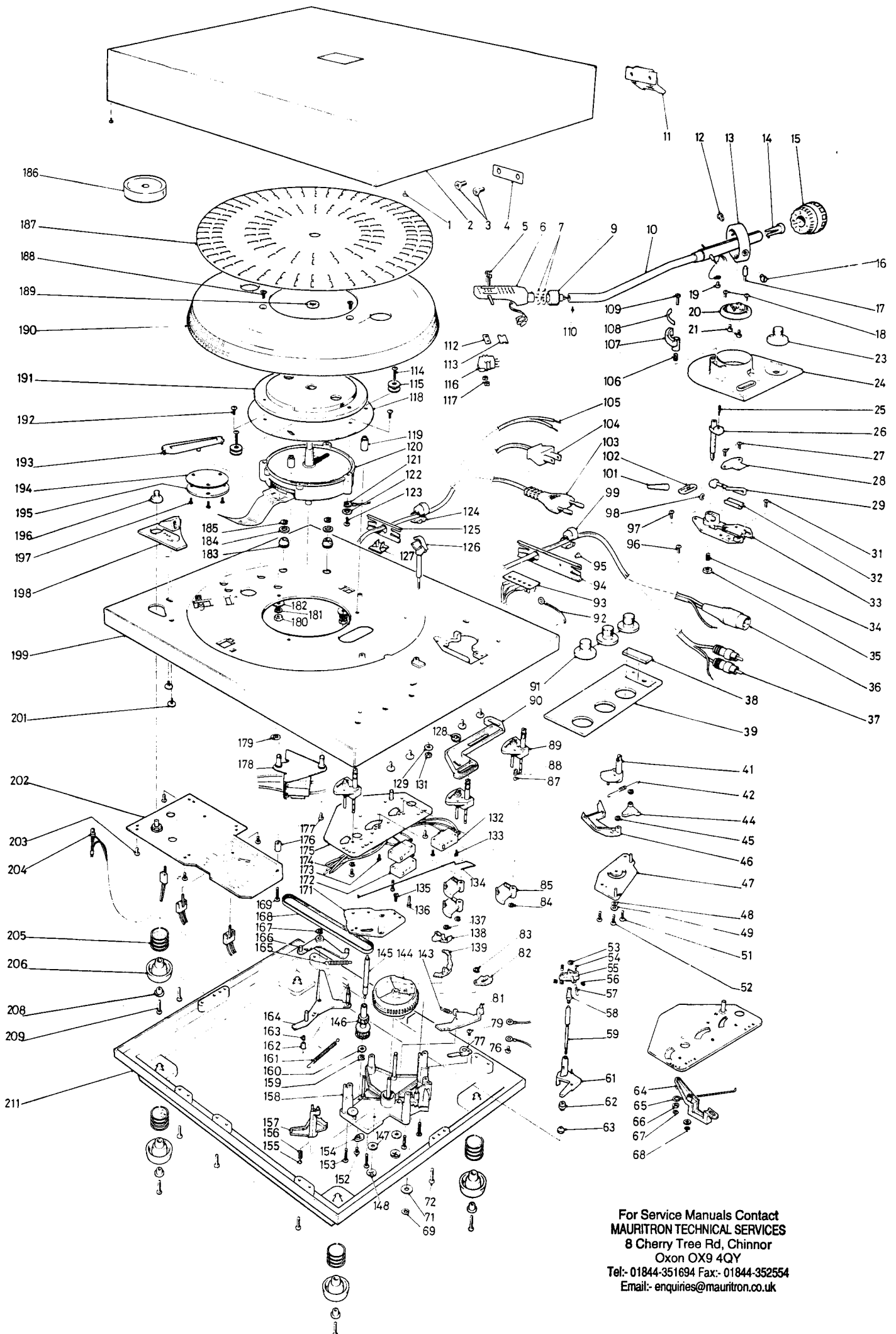

For Service Manuals Contact
MAURITRON TECHNICAL SERVICES
 8 Cherry Tree Rd, Chinnor
 Oxon OX9 4QY
 Tel:- 01844-351694 Fax:- 01844-352554
 Email:- enquiries@mauritron.co.uk

Service notes

Numbers in brackets identify parts on the exploded view.

General

The owner's manual, provided with each DD131 and 132, contains the following information:

- Unpacking and setting up, with wiring connections.
- Fitting the cartridge and setting stylus force.
- Operating instructions.
- User's service adjustments, routine maintenance and fault-finding hints.

Speed adjustment

The pitch control (196) provides a range of about $\pm 3\%$ adjustment at both $33\frac{1}{3}$ and 45 rev/min.

In addition to this, there is a pre-set control for each speed with a range of approximately 10%. These are accessible through a pair of plain, round holes in the bottom cover (211), near the front, left-hand isolator foot (206). Both controls are set and locked during assembly and should not normally require further attention.

If the pitch control does not provide sufficient adjustment to obtain the correct speed then:

- Set it to the half-way position.
- Rotate the appropriate pre-set potentiometer through its hole in the bottom cover, using a small screwdriver. The hole nearer the front of the base is for 45 rev/min, the hole nearer the back for $33\frac{1}{3}$ rev/min. Turn the potentiometer sliders clockwise to increase, counterclockwise to reduce speed and pitch.

Dismantling

To gain access to the underside of the unit, remove the bottom cover (211) by taking out eight fixing screws (72). Clip the pickup arm to its rest (126) then lift off the turntable mat (187), turntable (190) and hub (191).

Remove the pickup arm counterbalance weight (15). The unit can now be turned upside down, to rest with its closed top cover (2) on a soft, level surface taking care to avoid scratches or other damage.

To remove a 'Heyco' lead clamp bush (99 or 124), and release a connecting lead, squeeze the compressible section of the bush firmly with pliers and withdraw the bush from the strain relief plate (94 or 125).

To remove control knobs (23, 91 or 196) simply pull them straight off.

Fitting a new motor (120) or printed circuit board (202).

(See Note 1 at end of spare parts list)

In order to provide the sinewave drive that minimises cogging torque, and wow and flutter it is necessary to match the electronic circuit of the P.C.B. to the motor during assembly. Ideally, these would be supplied as a factory-matched set. However, equivalent results can be obtained by carrying out the following adjustments:

- Drive balance**
Adjust trim potentiometer TP5 for equal phase voltage amplitude at pins 10 and 11 on socket SK4 while the motor is running with the automatic mechanism out of operation. For convenience, probes can be attached to the wire leads of R24 and R30 (180K resistors) nearest to the socket. Finally, seal TP5 with lacquer to prevent further movement.
- Drive offset**
Connect an oscilloscope to the end of R24 nearer the motor connecting socket. Switch on the turntable and play a record at $33\frac{1}{3}$ rev/min. The oscilloscope should display a 2.2Hz sinewave having about 1.2V peak-to-peak amplitude. With the 'scope switched for a d.c. coupled input, adjust TP3 to produce equal excursions of the sinewave each side of the true d.c. zero. Repeat this test, connecting the 'scope to the end of R30 nearer to the motor socket and adjusting TP4.
- Alternative method for adjustment of both drive balance and offset, using 'Lissajous figure'**
This method may be used only with a 'scope having X-Y facilities. Connect the X probe to the end of R25 nearer the motor connecting socket and the Y probe to the corresponding end of R30. Adjust the 'scope for a d.c. coupled input (about 0.2V per cm) and, with the player switched off, centralise the dot on the 'scope screen. Switch on the turntable and play a record. Adjust TP3 and TP4 to obtain equal excursions of the trace on each side of the X and Y axes respectively. Adjust TP5 to make the X excursions equal to the Y excursions, measured along the X and Y axes.

Circuit diagram, showing test voltages and waveforms

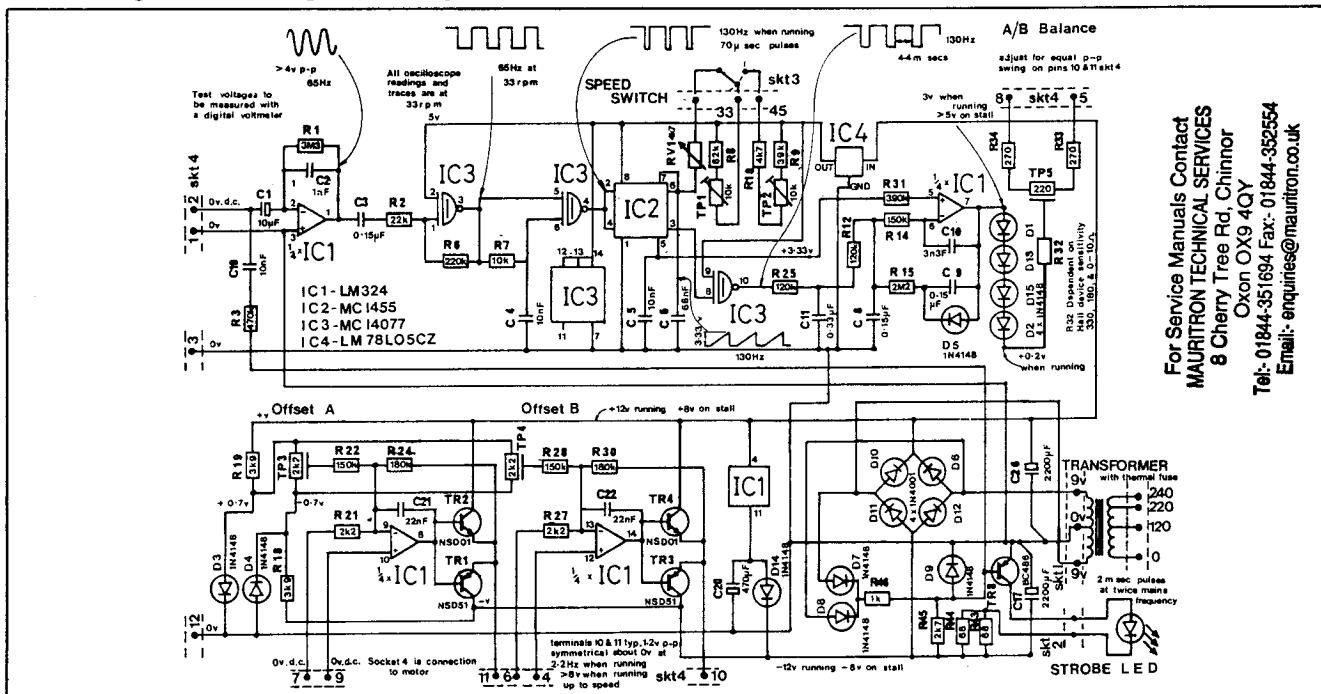

For Service Manuals Contact
MAURITRON TECHNICAL SERVICES
8 Cherry Tree Rd, Chinnor
Oxon OX9 4QY
Tel: 01844-351694 Fax: 01844-352554
Email: enquiries@mauritron.co.uk