

# Garrard

## Belt drive turntable Models GT-35 and GT-35P Servicing information

For Service Manuals Contact  
MAURITRON TECHNICAL SERVICES  
8 Cherry Tree Rd, Chinnor  
Oxon OX9 4QY  
Tel: 01844-351694 Fax: 01844-352554  
Email: enquiries@mauritron.co.uk

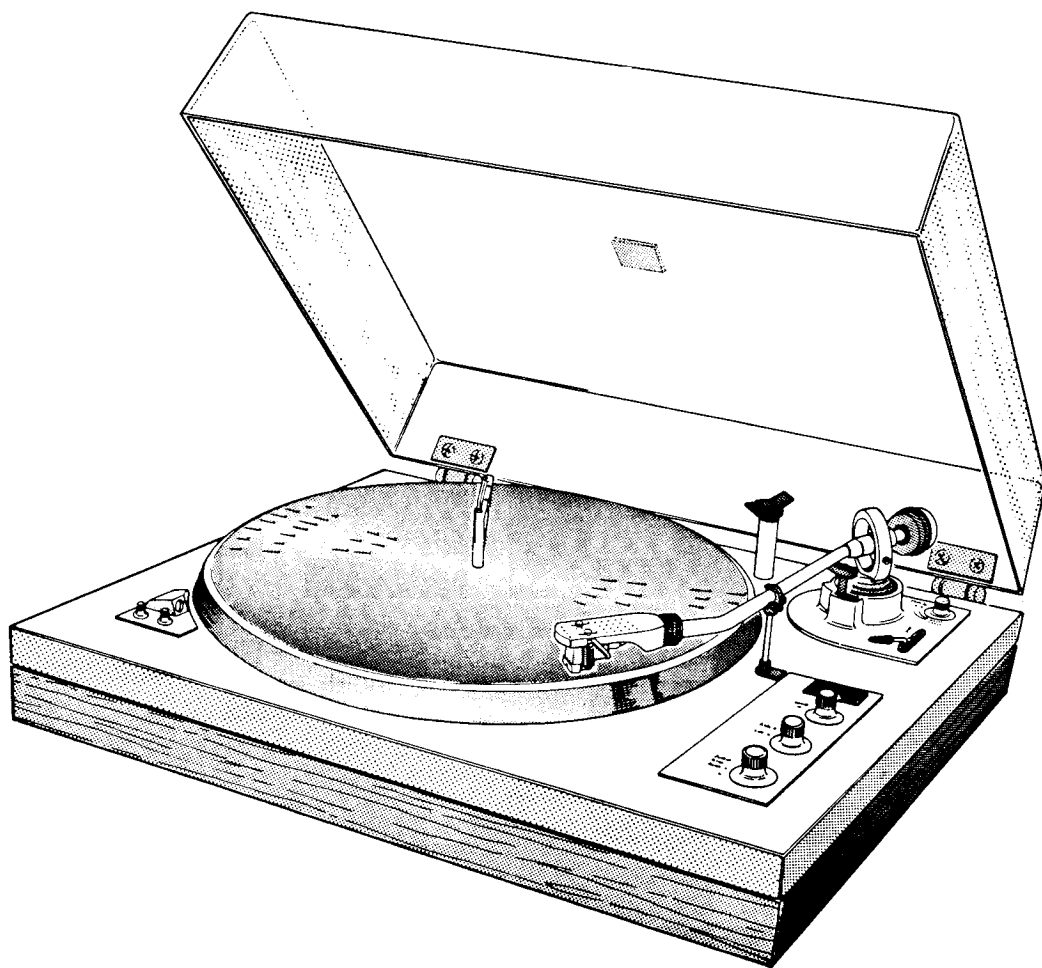

3674

**Model GT-35**

Garrard Sales Service Department,  
Crowdy's Hill Estate, Kembrey Street,  
Swindon, SN2 6BP, Wiltshire, England.  
Telephone: Swindon (0793) 41701.  
Telex: 44271.

In U.S.A. :  
Plessey Consumer Products,  
Garrard Dealer Sales Division,  
100 Commercial Street,  
Plainview, New York 11803.  
Telephone: (516) 938 8900.

# Contents Part 1 – GT-35

	<i>page</i>		<i>page</i>
General information	1	Release lever setting	
Specifications	2	Mechanism friction check – pickup arm movement	7
Installation	2	Motor pulley height setting	
Unpacking sequence		Access to components	7
Accessories – packed		Dismantling main component assemblies	7
Setting up	3	Pickup arm assembly complete	
Fitting a cartridge		Pickup arm assembly (less o/load and p.u. spindle assembly)	
Stylus force and bias compensator setting	4	Pickup base cover	
Phono connections		Lifting platform assembly	
Power supply connections		Bias compensator assembly	
Voltage setting		Mechanism module	
To play records	5	P.C.B. assembly	
To play a record manually		Stroboscope L.E.D. housing	
To play a record automatically		General views of unit	8
To repeat play		Exploded view	9
To interrupt play		Spare parts list for exploded view	10
To play a stack of records automatically		Circuit diagram – mains supply connections	11
To control drive speed and vary pitch of the recording		Circuit diagram – electronics	12
Service notes – adjustments	6	Modular fault diagnosis chart	13
Pickup arm lifting height		Servicing – fault diagnosis	14
Pickup arm lowering position (GT-35 only)		Modular mechanism – function and operation	17
Pickup arm return position		Routine maintenance	18
Cueing lowering rate			
Pickup cartridge angle (horizontal)			
Pickup headshell out of parallelism			
Pickup arm bearings (horizontal)			
Pre-set speed control			
Record support platform position (GT-35 only)			
Mechanism drive belt tension			
		<b>Part 2 – GT-35P</b>	
		Information	19

## General information

The GT-35 is the most sophisticated model of a new range of belt-driven integrated record changers. It is also produced in the single player form, as a semi-automatic model with a trip, lift and return to arm rest facility.

The GT-35 (changer) is a fully automatic unit employing a turntable drive through a flat rubber belt, from a DC servo-controlled motor, electronically regulated for 33½ rev/min and 45 rev/min speeds, to a moulded drive drum on to which a die-cast aluminium turntable platter and an anti-static rubber mat is placed. The turntable has an integral stroboscope pattern for both speeds and 50Hz and 60Hz power supply systems.

A newly-designed, low effective mass pickup arm assembly is fitted which is 'S' shaped with a detachable cast magnesium headshell from a bright anodized aluminium arm tube, integral counterbalance weight/stylus force adjuster and a combination of jewel and precision ball pivots to ensure the minimum of frictional forces. The manually operated cue/pause control and bias compensator control, calibrated for elliptical and CD4 (and conical) stylus forms, are housed in the pickup base cover. The operating functional controls at the right hand side of the base, provide power on/off with power on in the manual, automatic

and repeat modes, auto start/reject facility and speed selection of the two speeds.

Pitch control knobs are at the left hand side of the base, and provide ± 3% of the nominal speed (a semi-tone), and are located in the stroboscope illuminating L.E.D. housing. The GT-35 is made in two forms, with moulded base plinth or various wood grain finish. Plug-in sockets are provided at the back of the base for power supply input, DIN and RCA type connections for audio output.

The clear acrylic dust cover has spring assisted hinges which allow minimum effort to open, and ensures the records are played in clean conditions.

A low profile is obtained by recessing anti-vibration resonance resisting feet at the four corners.

Low and high range (110/125V and 220/240V respectively) versions are made for the U.S.A./Canadian market and the U.K./European market. Some special versions may have a voltage change-over switch to cater for dual power supplies.

For reasons of territorial and special customer's requirements, it is important to quote the eight figure code number of the unit (commencing 80030/—) in all enquiries.

Garrard's policy is one of continued development and therefore the Company reserves the right to alter specifications without notice.

**WARNING: To prevent fire or shock hazard, do not expose this appliance to rain or moisture.**

# Specifications

## Motor and turntable

Motor  
Drive  
Speeds  
Turntable size and type

Turntable moment of inertia  
Turntable weight  
Wow and flutter  
Rumble

## Pickup arm

Type  
Effective length  
Overhang  
Offset  
Tracking error

Effective mass (with Shure M95ED fitted)  
Horizontal pivot friction (with reference to stylus)  
Vertical pivot friction  
Acceptable cartridge weight  
Adjustable stylus force range  
Minimum tracking force

## General

Power supply  
Power consumption  
Dimensions

Weight

For Service Manuals Contact  
**MAURITRON TECHNICAL SERVICES**  
8 Cherry Tree Rd, Chinnor  
Oxon OX9 4QY  
Tel: 01844-351694 Fax: 01844-352554  
Email: enquiries@mauritron.co.uk

DC multi-pole servo controlled.  
Belt drive.  
33 $\frac{1}{3}$  rev/min and 45 rev/min, variable by  $\pm 3\%$  each.  
298mm/317mm dia. die-cast aluminium with integral strobe bars.  
263kg cm<sup>2</sup> (including mat).  
1.58kg (3.48lb) approximately.  
 $\pm 0.10\%$  weighted peak to DIN 45507.  
DIN A (unweighted) -45dB (typical).  
DIN B (weighted) -65dB (typical).

Direct static-balance, 'S' shape aluminium tubular.  
230mm (9.055in).  
17mm (0.670in).  
23° 24'  
+ 0.36' /cm at 5.14cm radius.  
- 0.145' /cm at 8.25cm radius.  
Zero error at 6.25cm radius and 11.15cm radius.  
18.86g.  
40mg.  
30mg.  
4 to 9g.  
0 to 3g (direct reading calibration).  
0.75g.

110/125V AC or 220/240V AC, 50Hz or 60Hz.  
2.5 watts.  
450mm x 360mm x 195mm (W x D x H).  
17.7in x 14.15in x 7.69in.  
6.5kg (14.40lb).

# Installation

## Unpacking sequence

- 1 Open the carton (1.8) and read any instructions on its top flaps.
- 2 Remove the cardboard top pad (1.1) and lift out the moulded dust cover (1.2).
- 3 Place one hand on each side of the mounting base (1.6) and carefully lift out the complete assembly. Seek help rather than risk damage at this stage.
- 4 Remove both support mouldings (1.7) from the back and front of the base and take out all the accessories in the cavities in the support mouldings.
- 5 Unpack the turntable platter (1.4) with its packing ring (1.5) and its mat (1.3).
- 6 Remove the wire tie from the pickup arm.
- 7 Store the packing materials for possible future use.

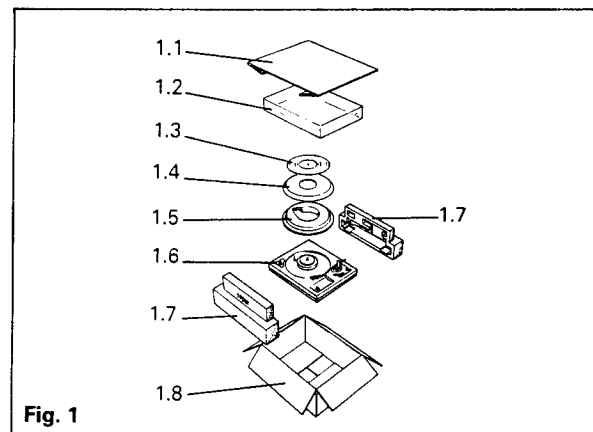

## Accessories – packed

The following accessories will be found in the support moulding cavities (1.7):

- 2.1 Headshell assembly. If cartridge is not fitted, screws and nuts for fixing one are provided.
- 2.2 A gauge to align the cartridge in the headshell for optimum tracking.
- 2.3 A multi-play record spindle.
- 2.4 A 45 rev/min single large hole record adaptor.
- 2.5 Pickup arm counterbalance weight.
- 2.6 A single-play record spindle.
- 2.7 A capsule of lubricating oil for routine maintenance.

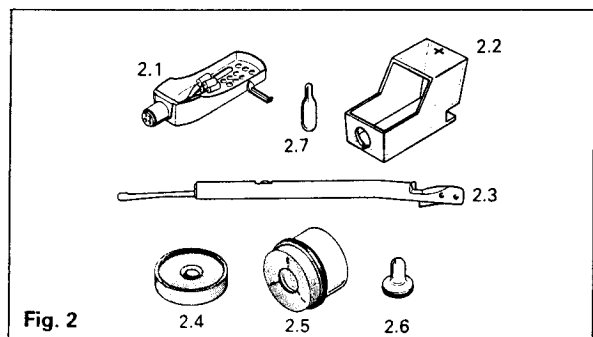

## Setting up

- 1 If the turntable drive belt (3.1) is not fitted when the unit is unpacked, it should be fitted around the drive drum (3.2) and the motor pulley (3.3). The belt must not be twisted, and any coloured identification mark (3.4) on the belt must face outwards.
- 2 Locate the turntable platter centrally on the drum and fit the rubber mat, ensuring that the central hole locates over the circular rib on the turntable drum.
- 3 (a) If there is a cartridge in the headshell already, attach the headshell to the pickup arm. To do this, secure the arm to its rest, then fit the locating pin on the headshell into the slot at the front of the arm tube (3b). Press the headshell gently inwards while turning the locking collar fully clockwise until the pin engages the collar as it turns and the headshell is drawn firmly in to make a good connection.  
(b) If a cartridge is not fitted, obtain one to suit your amplifier, then see section 'Fitting a cartridge' and paragraph (3a).
- 4 Fit the counterbalance weight by pressing it on to the back of the pickup arm tube with its black calibrated barrel facing the front of the arm.  
**Note:** The counterbalance weight must be removed from the arm before re-transit.
- 5 Set the stylus and bias compensator controls as directed in Section 5.
- 6 Attach the connecting leads, see Section 6.
- 7 Fit the dust cover. To do this, lift the front of the cover so that both spring assisted hinges can be fitted in to their slots in the back of the base.

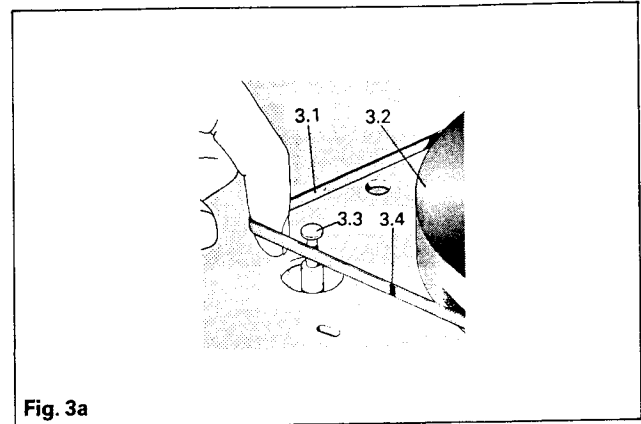

Fig. 3a

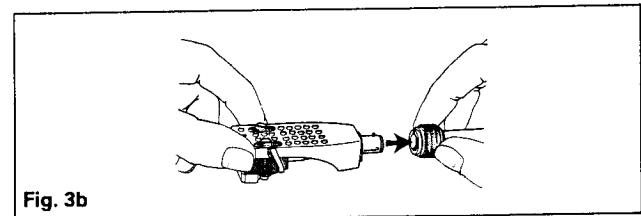

Fig. 3b

The cover is designed to stay open at almost any angle.

- 8 Secure the pickup arm, set the mode selector (7.4) to 'Manual' and turn the turntable platter clockwise. Return the selector to 'Off' if it does not soon do so. See figure 7a.

## Fitting a cartridge

If a cartridge is supplied with the unit, disregard the following instructions.

If a cartridge is not supplied, fit as follows:

- 1 Lock the pickup arm on its rest, by means of the safety catch, then turn the arm headshell (4.5) over and fit the cartridge (4.2) to it, having first removed the stylus assembly in its positioning carrier. Great care must be taken in doing this to prevent damage to the stylus bar.

The cartridge is then fitted to the headshell by passing a pair of screws of suitable length (4.6) through the slots in the top of the headshell, through the holes or slots in the cartridge and into a pair of round nuts (4.1).

The shape of a small minority of cartridges causes them to slope sufficiently for the heel of the cartridge to touch the record. If this happens, fit the tilt wedge (4.3) inside the headshell with the deep edge forward. Similarly, a few cartridges are more shallow than most. These will cause the arm to slope downwards when playing a record. In this case fit one or two pairs of spacing washers (4.4), as shown, to level the arm.

If a light cartridge causes difficulty in setting the stylus force, fit the slotted auxiliary weight (not shown) inside and next to the headshell.

- 2 Push the tags on the four coloured connecting leads (4.7) in the headshell, on to the corresponding cartridge output pins, using a pair of tweezers if these are available. Connecting leads use the following code:

Red – Right channel signal  
Green – Right channel ground  
White – Left channel signal  
Blue (or Black) – Left channel ground

- 3 Slide the pickup headshell, with stylus carrier replaced, into the setting gauge (figure 4b), taking care not to damage the stylus.

With the cartridge body parallel to the sides of the headshell,

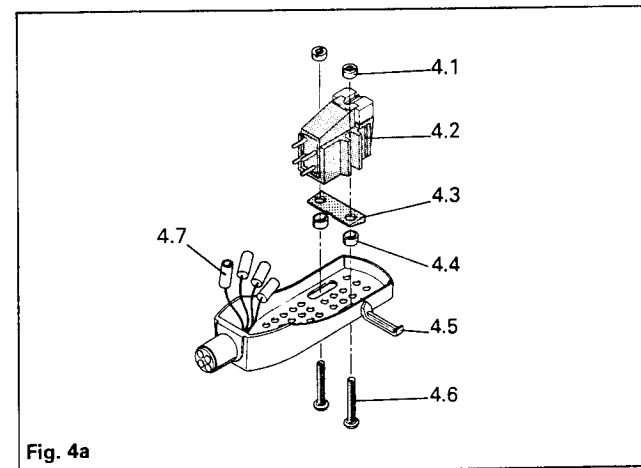

Fig. 4a

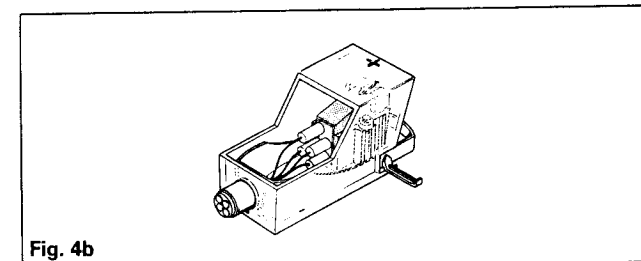

Fig. 4b

the stylus tip must be vertically below the point at which the lines on the gauge cross.

- 4 Tighten both fixing screws equally and recheck the stylus position. If it is correct, remove the headshell with cartridge from the gauge.

## Stylus force and bias compensator setting

- 1 Secure the pickup arm to the rest, fit the short record spindle and place a record on the platter.
- 2 Press the counterbalance weight (5.1) with its black calibrated barrel (5.2) facing the pickup head, half-way along the tube at the back of the pickup arm.
- 3 Turn the bias control (5.4) to '0' and remove the stylus guard or swing it aside, according to type.
- 4 Release the pickup arm and support it above the outside edge of the record.
- 5 Wind the weight backwards or forwards along the arm tube until it balances with the stylus tip just clear of the record surface. Secure the arm in its rest.
- 6 Hold the body of the counterbalance weight still and turn the black barrel until the '0' mark is at the red line (5.3) on the top of the arm tube. Balance will be upset if the weight is accidentally turned with the barrel.
- 7 Turn the weight and barrel together in an anti-clockwise direction (seen from the front of the arm) until the figure corresponding to the required stylus force in grams is at the red line. The barrel is calibrated from 0-3g in  $\frac{1}{4}$ g steps. Minimum stylus force with a capable cartridge is  $\frac{3}{4}$ g. Set the stylus force recommended by the cartridge manufacturer. When Garrard fits a cartridge, its stylus force range (in grams) is shown on the identification ticket on the packing carton.

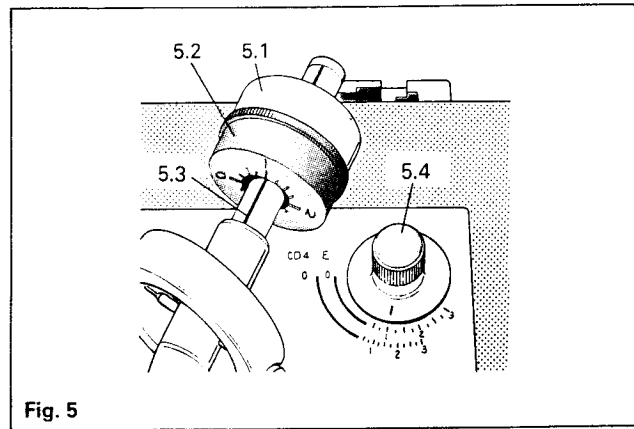

Fig. 5

- 8 Set the bias compensator force as follows:

The bias compensator control (5.4) has two calibrated scales: one for cartridges with elliptical styli (E) and one for cartridges with a CD4 (or conical) stylus. Turn the control knob to correspond with the stylus force already set. For instance, if a cartridge with an elliptical stylus calls for a stylus force of 1g, set the calibration mark on the control to the figure 1 on the E scale (as shown).

## Phono connections

The following instructions should be read together with the amplifier manufacturer's recommendations.

A simple but effective method of linking the pickup output sockets allows the unit to be connected to almost any amplifier. The Garrard phono connecting lead is of low capacitance and suitable for any stereo or 4-channel system.

Right channel coding:

Red, brown or black plug. Socket R.

Left channel coding:

White or grey plug. Socket L.

If the amplifier has RCA type phono input sockets:

- 1 Attach the phono plugs on the Garrard connecting lead to these.
- 2 Connect the bared end of the signal ground lead to the ground terminal on the amplifier, to reduce hum.\*
- 3 Attach the 5 pin DIN type plug on the other end of the lead to the DIN type socket (6.3) on the turntable base panel.

If the amplifier has a 5 way DIN type input socket:

- 1 Attach the 5 pin DIN type plug on the Garrard phono connecting lead to this.
- 2 Attach the RCA type plugs on the other end of the lead to the RCA type sockets (6.2) on the base.
- 3 Press the spring-loaded ground terminal (6.1) on the base and insert the bared end of the signal ground lead to minimise hum.\*

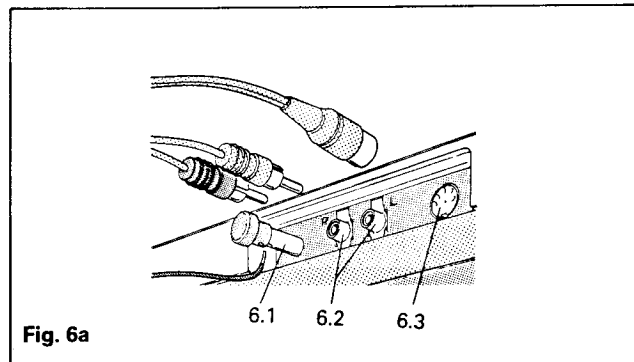

Fig. 6a

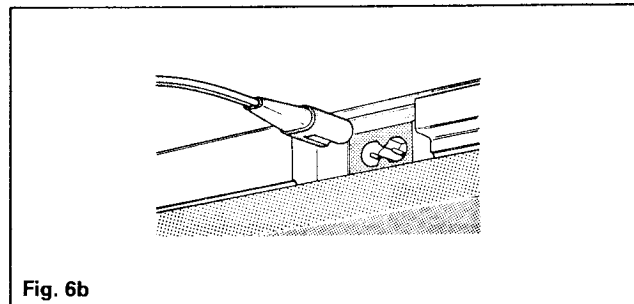

Fig. 6b

\*If both ends of the ground lead are bared, connect it between the ground terminals on the record player (6.1) and the amplifier chassis.

## Power supply connections

- 1 Attach the plug of the Garrard connecting lead to the power supply input socket on the back of the base, see figure 6b.
- 2 Connect the AC power plug on the other end of the lead to any normal household AC outlet, or to the accessory outlet on the amplifier.

## Voltage setting

Voltage setting does not apply to U.S.A. and Canadian models. These are built specifically for 110/125V AC power supplies.

Voltage setting will also not be applicable to models in general, for other world markets. These models will be built specifically for 220/240V AC power supplies. Special variants of the model will be dual voltage, 110/125V AC and 220/240V AC power supplies.

These variants will be fitted with a voltage change switch, which is accessible when the turntable is removed from its centre spindle. It is located in the top surface of the base at the rear of the area covered by the turntable.

The switch will show '115' for 110/125V or '230' for 220/240V power supplies. Check that the switch is set for the power supply in use. If incorrect, slide the switch to the appropriate value.

For Service Manuals Contact  
MAURITRON TECHNICAL SERVICES  
8 Cherry Tree Rd, Chinnor  
Oxon OX9 4QY  
Tel:- 01844-351694 Fax:- 01844-352554  
Email:- enquiries@mauritron.co.uk

# To play records

Open the dust cover and check that the stylus guard has been removed or swung clear, according to type, and that the stylus is correct for the record. Release the pickup arm from its rest by moving the safety catch (7.2) aside. See also figure 7b.

## To play a record manually

- 1 Fit the short, single-play record spindle and place a record on the turntable.
- 2 Select 33 $\frac{1}{3}$  or 45 rev/min speed (7.3). Set the playing mode selector (7.4) to 'Manual'.
- 3 Swing the cue lever (7.1) to  $\surd$  to raise the arm and position the stylus over the beginning of the record, using the finger lift on the side of the headshell.
- 4 Ease the cue lever to  $\surd$  to lower the pickup on to the record. After playing the record the pickup arm will return to its rest and the unit will switch off.

## To play a record automatically

- 1 Fit the short, single-play record spindle and place a record on the turntable.
- 2 Select 33 $\frac{1}{3}$  or 45 rev/min (7.3), according to turntable speed. At 33 $\frac{1}{3}$  the pickup arm is automatically set to play 12in records. At 45 it is set to play 7in records.
- 3 Set the mode selector to 'Automatic'. To begin to play the record, turn the auto selector (7.5) to 'Start'. Hold it there for a moment, then release it.

## To repeat play

To play a single record (or the last of a stack) continuously, turn the selector to 'Repeat'. To resume normal play, turn the selector to 'Manual'.

## To interrupt play

To stop play for a short time, move the cue control lever gently to  $\surd$ .

To continue, move it to  $\surd$ .

## To play a stack of records automatically

- 1 Fit the long, multiple-play record spindle. Insert only when the pickup arm is on the rest, and turn it until it can be pressed fully down into place.
- 2 Place up to five 33 $\frac{1}{3}$  rev/min, 12in records on the spindle, with the edge of the lowest record resting on the support platform (7.8). Lift the record steady until it can be swung inwards and down to bear lightly on the top of the record stack. See figure 7c.
 

To play up to five 45 rev/min records with large centre holes, use Garrard LRS100 Mk2 record spindle, available from your dealer as an optional extra.
- 3 Select 33 $\frac{1}{3}$  or 45 rev/min, according to record speed. At 33 $\frac{1}{3}$  the pickup arm is automatically set to play 12in records. At 45 it is set to play 7in records.
- 4 Set the mode selector to 'Automatic'. To begin playing the records, turn the auto selector to 'Start'. Hold it there for a moment, then release it.

After playing all the records, the arm will return to the rest and the unit will switch off. Remove the records by lifting them clear of the record spindle, even if they are to be played again immediately.

To interrupt a record during play and play the next, move the auto control to the 'Reject' position.

To switch off while playing a stack of records, move the mode selector to 'Manual', then the auto control to 'Reject' – this will first cause the next record to be lowered.

## To control drive speed and vary pitch of the recording

The DC servo-controlled motor ensures that the turntable revolves without variation from its exact 33 $\frac{1}{3}$  and 45 rev/min setting. It is revolving at the precise speed when the appropriate row of bars on the turntable rim appears to be stationary, when illuminated by stroboscope light emitting diode (L.E.D.).

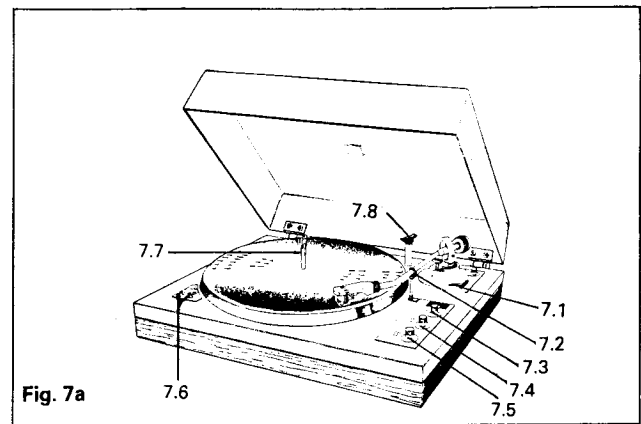

Fig. 7a

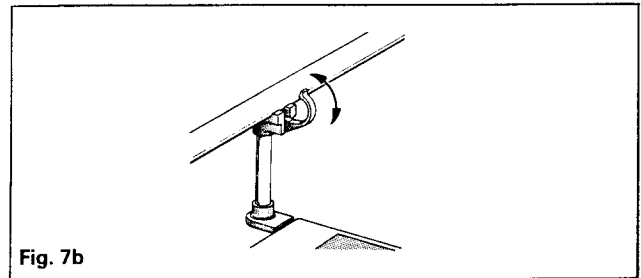

Fig. 7b

For Service Manuals Contact  
**MAURITRON TECHNICAL SERVICES**  
 8 Cherry Tree Rd, Chinnor  
 Oxon OX9 4QY  
 Tel:- 01844-351694 Fax:- 01844-352554  
 Email:- enquiries@mauritron.co.uk

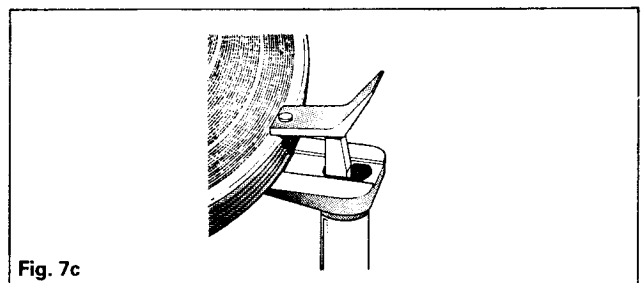

Fig. 7c

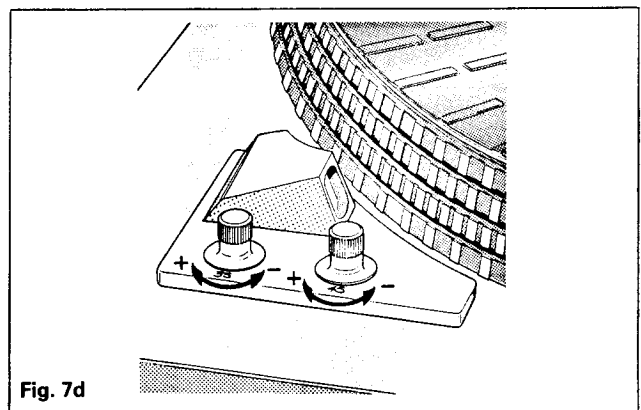

Fig. 7d

row of bars	rev/min	power supply
top	45	50Hz
2nd	33 $\frac{1}{3}$	50Hz
3rd	33 $\frac{1}{3}$	60Hz
bottom	45	60Hz

To raise pitch, by increasing speed, turn the 33 $\frac{1}{3}$  or 45 knob (7.6) clockwise. To lower pitch, turn the knob anti-clockwise. See figure 7d.

# Model GT-35 service notes

## Service adjustments

### Pickup arm lifting height

After playing a record, the arm will lift off the record, return to its rest and swing in again to lower on to the next record and continue to cycle whilst there are records on the record spindle (GT-35 only).

When the last record of a stack on the record spindle has been played (GT-35) or after playing one record manually, the arm will lift, return to its rest and the unit will switch off. A restrictor prevents the arm lifting too high and on the GT-35 prevents the top of the headshell hitting the underside of a record on the record spindle. The restrictor also prevents the arm bouncing when it is cued up manually and quickly.

If adjustment is required:

- 1 Switch the power off as the arm returns to its rest. Turn the restrictor screw (8.1) clockwise to disengage it.
- 2 Turn the lifting height adjusting screw (8.2) clockwise to reduce or anti-clockwise to increase height (limited by record on auto spindle).
- 3 Reset the restrictor screw by turning it until there is about 1.5mm free upward movement at the front of the arm.
- 4 Switch the unit on again to allow the automatic cycle to be completed.

### Pickup arm lowering position (GT-35 only)

The stylus should land on the record at the bottom of the sloping groove guard rim, just before the start of the playing groove.

If adjustment is needed:

Hold arm by hand at the rest position (protect stylus) and turn the adjusting screw (8.3) clockwise to move the stylus set-down position in, or anti-clockwise to move it further out.

### Pickup arm return position

If the pickup arm overshoots its rest position after playing records, set the cue lever to  $\nabla$ , move the pickup arm fully outwards and steady it while turning the adjusting screw (8.4) clockwise one turn. Test again.

### Cueing lowering rate

The cueing lowering rate has been adjusted during assembly, but if for any reason it requires adjustment to increase or decrease the rate, this may be achieved by rotating the nut (108) at the bottom end of the cueing lifter spindle clockwise to increase the rate or anti-clockwise to decrease the rate of lowering. This adjustment also alters the pickup arm lifting rate.

Should the preceding adjustment fail to reduce the rate of cueing or lifting, the mechanism will require to be removed from the unit in order to apply a charge of viscous damping fluid to the lifter spindle. See 'Dismantling main component assemblies'.

### Pickup cartridge angle (horizontal)

Detach the headshell from the pickup arm and slide it into the setting gauge supplied, taking great care not to damage the stylus. Slacken the two screws holding the cartridge to the headshell and reposition so that the stylus coincides with the graticule on the setting gauge and the cartridge lies parallel with the sides of the headshell. Tighten the screws and recheck the stylus position and angle of cartridge.

### Pickup headshell out of parallelism

If the headshell is not parallel with the top of the turntable to within  $\pm 1^\circ$ , adjustment is made by:

Slacken the small screw (78) under the arm tube to the rear of the headshell connection. Gently turn the headshell in the required direction until parallel. Tighten screw.

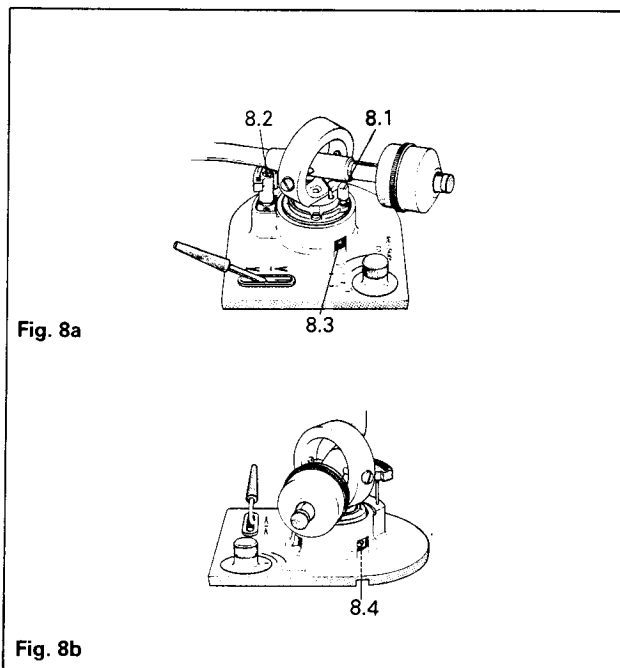

### Pickup arm bearings (horizontal)

The horizontal arm pivots must be quite free, under spring pressure, with a minimum end play of 0.25mm (0.01in).

No adjustment is provided, but make sure that the right hand pivot screw is tight. Change spring-loaded pivot screw (16) as necessary.

### Pre-set speed control

With the base plinth or the wood finish plinth cover removed, select for  $33\frac{1}{3}$  rev/min and the pitch control knob in its mid-travel position, adjust the pre-set potentiometer on the P.C.B. so that the appropriate strobe band on the turntable appears stationary with the unit running.

Repeat for 45 rev/min speed.

### Record support platform position (GT-35 only)

The top front edge of the support platform (24) should be at 151mm (5.95in) radius from the turntable centre.

Slacken the screw (28) on the underside of the base and move the platform in the direction necessary until a 12in record, of international recognised size, on the multi-play record spindle overlaps the top edge of the platform by 1.6mm (0.062in).

Tighten screw.

### Mechanism drive belt tension

To set the belt tension:

With turntable, drive drum and belt removed, and access to the underside of the base, slacken screws (183) securing turntable spindle housing (177). Bias the spindle housing to the left of centre of the unit base moulding with a load of 1400g, such that the mechanism drive belt tightens. Insert the setting block in the slot in the base and locate the drive belt against the flat. Secure the spindle housing. Ensure the spindle housing does not move during this operation.

With the setting block still in position and locating the belt, the force required to close the loop of the belt together to be 90 to 120g.

### Release lever setting

To set the release lever effective length, remove the record spindle and replace with Gauge No. GT64477. With access to the underside of the base, ensure the cam gear (131) is indexed in the neutral (play) position.

Place the release lever assembly on the gauge protruding from the turntable spindle housing, and rotate the adjusting screw (133) in the required direction, alter the effective length such that the end of the slot in the overload moulding (end nearest the adjusting screw) just clears the pin diameter in the cam lever (158). Complete assembly and remove the gauge.

### Mechanism friction check – pickup arm movement

Rotate the cam (131) anti-clockwise until the moulded pin of the selector lever (117) is located at the bend of the slot in the inter-selector lever (115). Hold the selector lever in this position, continue to rotate the cam until the steel pin on the pickup lever (75) just touches the smallest radius face on the inter-selector lever. The force then applied tangentially to a line between the small radiused end of the arm of the pickup lever and the pickup arm vertical pivot centre, at the radiused end and in an outward direction, must be a minimum of 35g to 'break' the friction assembly on the cam lever.

Adjust friction of the friction assembly on the cam lever by

turning the red lacquered nut in a clockwise direction. Relacquer when the adjustment is completed.

### Motor pulley height setting

To adjust the height of the motor pulley (213) obtain access to the underside of the base. Remove the three circlips (212) and washers (211) and withdraw the motor and transformer mounting plate assembly from its grommets in the base moulding. Support the plate assembly and loosen the two grub screws (213) which retain the pulley on the motor spindle.

Adjust the position of the pulley so that the bottom face of the pulley is 1.5mm (0.60in) from the top surface of the mounting plate. Retighten the two grub screws and insert the pillars on the mounting plate assembly into the grommets, making sure that the pillars are fully home and supported by the grommets. Replace the washers and the circlips.

If pulley is fitted to motor spindle without grub screws, replace motor and pulley assembly.

## Access to components

Disconnect the power supply as appropriate, when carrying out service work.

Carefully remove the turntable and mat for convenient handling of the unit.

To obtain access to components on the underside of the unit, carefully support the unit to avoid damage.

When the unit is fitted with a moulded plinth (196), remove the eight self-tapping screws (191).

The reference numbers used in the foregoing paragraphs and the following text are those corresponding to parts shown on the exploded view diagram.

When the unit is fitted with a wood finish type plinth (46), remove the ten screws (48) which retain the cover (47) to the plinth. This will give access to the main components, but not for the removal of all of them. To do this, the wood finish type plinth will need to be removed from the base by extracting the eight self-tapping screws (49).

For Service Manuals Contact  
**MAURITRON TECHNICAL SERVICES**  
8 Cherry Tree Rd, Chinnor  
Oxon OX9 4QY  
Tel:- 01844-351694 Fax:- 01844-352554  
Email:- enquiries@mauritron.co.uk

## Dismantling main component assemblies

### 1 Pickup arm assembly complete

This necessitates the removal of the wood finish type plinth if fitted.

Remove the screw and washer (55 and 54) and lift off the shield (53). Unsolder the pickup leads at the phono connections on the panel (29). Remove all lead dressing attached to the base and mechanism casting. Remove the nut (77) from the p.u. spindle (74) at the bottom face of the mechanism casting (locked with coloured loctite). Withdraw the pickup arm assembly upwards through the aperture in the base moulding taking care to feed the pickup lever (75) through.

### 2 Pickup arm assembly (less o/load and p.u. spindle assembly)

As in 1 above except do not remove nut (77) from p.u. spindle (74). Remove the two screws (15) which attach the arm sub-assembly through the gimbal support to the overload and p.u. lever assembly. The arm sub-assembly may now be lifted off the unit. Care must be taken to ensure the p.u. leads do not snag as they are withdrawn. Also, when replacing the arm assembly, ascertain that the yellow grounding lead is attached to its tag at the gimbal.

### 3 Pickup base cover

Having first removed the pickup arm as in 1 or 2 above, pull off the bias control knob (85) and the cue lever knob (105), undo the two screws (220) with their washers and lift off the pickup base cover.

### 4 Lifting platform assembly

This is removed from the base moulding by undoing the three retaining screws (95).

### 5 Bias compensator assembly

Pull off the bias control knob (85) and remove the two retaining screws (45). The bias plate assembly (41) can be removed by

feeding the tail of the bias lever (39) around its operating pin on the pickup lever (75).

### 6 Mechanism module

Remove the pickup arm as described in paragraph 1. Remove any grounding lead which may be attached to the mechanism casting. Disconnect the drive belt (153) by first removing the pinion bearing and its retaining screw (186) and (187). Withdraw the pinion spindle (159) through the hole vacated by the pinion bearing. Care must be taken to recover the brass washer (164) which is fitted to the pinion spindle, between the retaining circlip (165) and the end of the pinion (161).

Applicable to GT-35 changer only – detach the release lever (143) from the cam lever (158) by removing the circlip (132). Remove the selector control lever and link (65) by unclipping the retaining circlip (113), and withdraw the link from engagement with the mechanism.

Applicable to GT-35 and GT-35P – remove the four screws (188) which retain the module to the base moulding. The module can now be taken off the base by easing the casting locating pegs out of their tight-fitting location holes in the base moulding.

### 7 P.C.B. assembly

This is removed from the unit simply by first disconnecting the multi-pin plugs from their sockets on the p.c.b. and removing the screws (216) at each corner of the board.

### 8 Stroboscope L.E.D. housing

Two attachment screws (220) with washers (221) are accessible through holes in the p.c.b. Disconnect the two-pin plug from its socket, pull off the two pitch control knobs from their potentiometers, undo the two retaining screws and lift off the housing.



# General views of unit above and below base

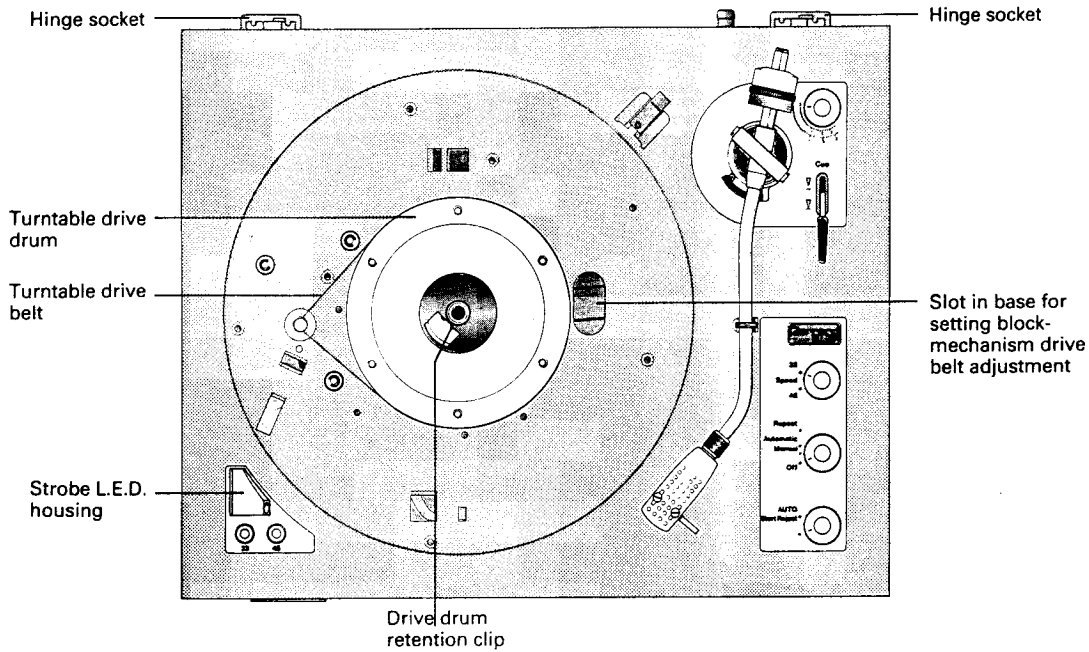

Top view

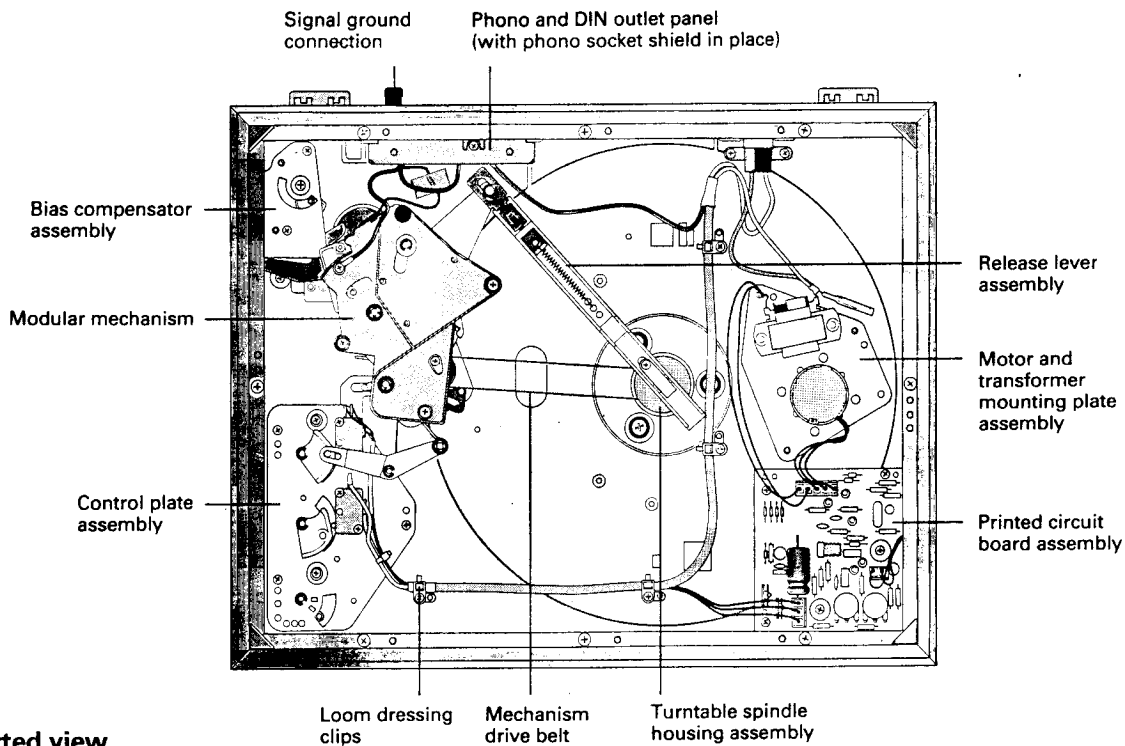

Inverted view

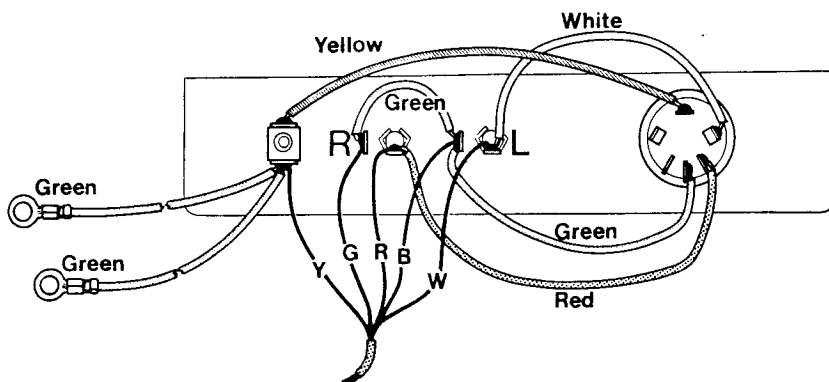

## Phono and DIN connections

- (R) Red – Right channel signal
- (G) Green – Right channel ground
- (W) White – Left channel signal
- (B) Black or Blue – Left channel ground
- (Y) Yellow – Pickup ground

Phono connections (RCA type):  
 Grey phono lead: Left channel  
 Brown or Black phono lead: Right channel

# Model GT-35 exploded view

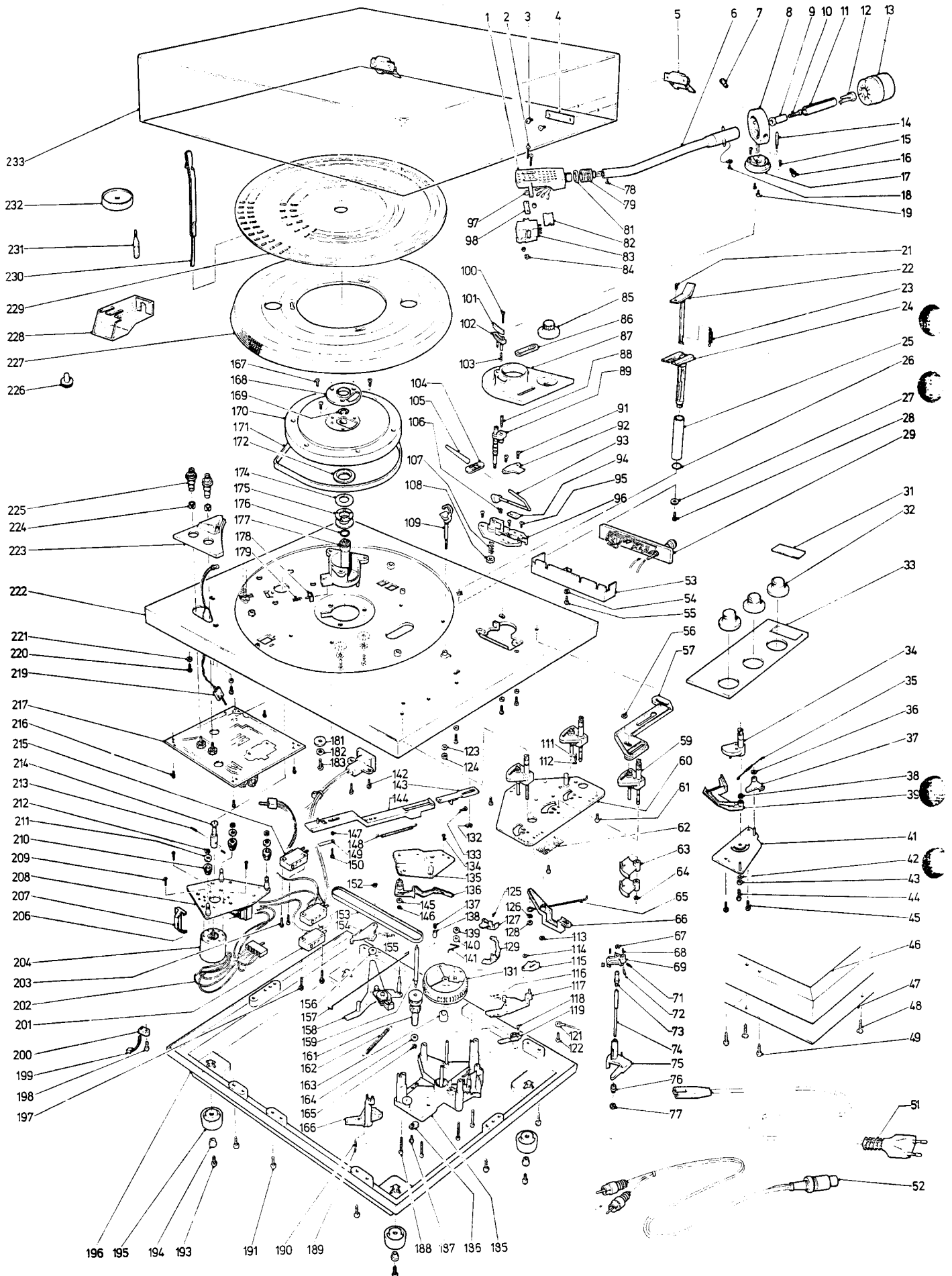

# Model GT-35 spare parts list

Ref. No.	Garrard Part No.	Description	Ref. No.	Garrard Part No.	Description
1	606/1/80627/001	Type H1 pickup head with fixing kit	81	606/2/41235/002	Washer
	606/1/80570/001	Type H1 pickup head with leads	82	606/2/80696/001	Auxiliary weight
2		M2.5 screw, length to suit cartridge (2)	83		Cartridge (please state type)
3	999/4/31019/001	Screw (4)	84	606/2/78480/001	Nut (2)
4	606/7/80199/001	Clamp plate (2)	85	606/7/80073/001	Control knob
5	606/7/80174/001	Hinge (2)	86	606/7/80208/001	Lever surround
6	606/1/80216/001	Pickup arm tube with gimbal	87	606/1/80232/001	Pickup arm trim with surround
7	606/7/80193/001	Pivot screw	88	606/2/80156/001	Adjusting screw
8	606/1/80231/001	Gimbal with support	89	606/1/80207/001	Cueing lifter
9	606/7/78475/001	Isolator	90		Not used
10	606/2/78494/001	Screw	91	999/4/30979/003	Screw (2)
11	606/2/80142/001	Tube	92	606/2/80124/001	Cueing plate
12	606/7/78474/001	Tensioner	93	606/1/80240/001	Cue lever
13	606/1/80228/001	Counterbalance weight	94	606/2/80688/001	Friction pad
14	606/2/80183/001	Restrictor screw	95	999/4/31029/017	Screw (3)
15	999/4/31039/001	Screw (2)	96	606/1/80241/001	Cueing assembly with lifter and lever
16	606/7/80194/001	Pivot screw	97	606/2/80673/001	Spacer (2)
17	606/2/80204/001	Gimbal support	98	606/2/75392/001	Tilt wedge
18	999/4/01145/002	Screw	99		Not used
19	999/4/00411/052	Screw (2)	100	606/2/80167/001	Screw
20		Not used	101	606/7/80086/001	Insert
21	606/2/80800/001	Grommet	102	606/1/80229/001	Lifting platform with insert
22	606/2/80699/001	Record clip	103	606/7/67047/001	Spring
23	606/7/67032/001	Spring	104	606/7/80075/001	Cueing trim
24	606/7/80083/001	Record platform	105	606/7/80504/001	Cue lever knob
25	606/2/80182/001	Trim tube	106	999/4/00431/036	Spring clip
26	606/2/80689/001	Platform washer	107	606/7/45017/001	Spring
27	606/2/41218/014	Washer	108	606/2/80256/001	Nut
28	999/4/31029/017	Screw	109	606/1/80233/001	Pickup rest
29	606/1/80485/001	Phono and DIN output panel	110		Not used
30		Not used	111	606/7/44644/001	Spring
31	606/2/80500/002	Name plate	112	606/7/80171/001	Ball
32	606/7/80073/001	Control knob (3)	113	606/4/79526/001	Spring clip
33	606/1/80476/002	Control trim with nameplate	114	999/4/00431/002	Spring clip
34	606/7/80091/001	Bias cam	115	606/7/80206/001	Inter selector lever
35	606/7/67043/001	Bias spring	116	606/7/44668/001	Spring
36	999/4/00431/046	Spring clip	117	606/7/78672/001	Selector lever
37	606/7/80092/001	Bias lever	118	999/4/30979/002	Screw
38	999/4/00431/046	Spring clip	119	606/7/79879/001	Lifting blade
39	606/7/80203/001	Bias lever	120		Not used
40		Not used	121	501/1/60343/153	Earth lead
41	606/1/80474/001	Bias assembly with lever, cam and follower	122	999/4/30979/001	Screw
42	606/4/42561	Spring washer	123	999/4/00852/008	Washer
43	606/2/41234/002	Plain washer	124	991/4/01911/004	Nut
44	999/4/01515/020	Screw	125	999/4/00431/002	Spring clip
45	999/4/31029/017	Screw (2)	126	606/2/41218/068	Washer
46	606/7/80179/001	Plinth - walnut style	127	606/7/80400/001	Trip pawl
	606/7/80179/002	Plinth - rosewood style	128	999/4/30993/002	Fastener
	606/7/80179/003	Plinth - teak style	129	606/7/80399/001	Trip friction lever
47	606/1/80218/001	Bottom cover with feet	130		Not used
48	999/4/00973/028	Screw (8)	131	606/1/80398/001	Main cam complete
49	999/4/31029/049	Screw (8)	132	999/4/00431/021	Circlip
50		Not used	133	999/4/30979/006	Screw
51	606/1/80514/001	Line cord (U.S.A. and Canada)	134	999/4/30976/002	Screw
	606/1/80515/001	Mains lead (U.K. no plug)	135	606/1/80484/001	Support plate
	606/1/80518/001	Mains lead (with Europlug)	136	606/7/80097/001	Cycle lever
52	606/1/80517/001	Audio connecting lead	137	606/7/67048/001	Wire clip
53	606/2/80129/001	Phono socket shield	138	606/2/80719/001	Roller
54	999/4/00852/008	Washer	139	999/4/30993/002	Fastener
55	999/4/31029/017	Screw	140	606/2/41234/002	Washer
56	999/4/30993/001	Fastener	141	606/7/44643/001	Spring
57	606/7/80093/001	Programme actuating lever	142	999/4/31029/018	Screw (2)
58		Not used	143	606/7/80255/001	Overload arm
59	606/1/80222/001	Control moulding (3)	144	606/7/80200/001	Release lever
60	606/1/80217/004	Control plate with mouldings	145	606/2/41218/063	Washer
61	999/4/31029/017	Screw (3)	146	999/4/00431/011	Spring clip
62	606/7/80495/001	Insulator pad	147	606/2/79934/001	Spacer
63	606/7/80101/001	<b>Switch lever (3)</b>	148	606/7/67031/001	Spring
64	606/4/79526/001	<b>Spring clip (2)</b>	149	606/2/79241/001	Spring blade
65	606/7/80191/001	Selector link	150	999/4/30979/004	Screw
66	606/7/80094/001	Selector actuating lever	151		Not used
67	999/4/01167/004	Spring clip	152	999/4/02654/001	Spring clip
68	606/2/78476/001	Nut (2)	153	606/7/78973/001	Drive belt
69	606/1/80471/001	Overload casting complete	154	606/7/78670/001	Index lever
70		Not used	155	606/4/44699/001	Spring
71	991/4/01665/039	Screw	156	606/2/41234/003	Washer
72	606/4/44448/001	Overload spring	157	606/7/80172/001	Impulse link
73	606/7/80197/001	Vertical jewel bearing	158	606/1/80632/001	Cam lever assembly
74	606/1/80235/001	Pickup spindle	159	606/2/78628/001	Pinion spindle
75	606/1/80470/002	Pickup lever	160		Not used
76	606/2/80163/001	Collar	161	606/1/80220/001	Pinion
77	606/2/80143/001	<b>Pickup spindle nut</b>	162	606/7/44690/001	Spring
78	999/4/02077/039	<b>Screw</b>	163	606/2/80321/001	Cueing damper
79	606/1/80237/001	Pickup arm sleeve with grip ring and leads	164	606/2/41218/055	Washer
80		Not used	165	999/4/00687/006	Spring clip

# Model GT-35 spare parts list (continued)

Ref. No.	Garrard Part No.	Description
166	606/1/80573/001	Programme lever
167	999/4/31031/019	Screw (3)
168	606/7/80089/001	Manual spindle housing
169	606/4/43857/001	Spring clip
170	606/1/80214/001	Drive hub complete
171	606/7/76992/001	Drive belt
172	606/7/80503/001	Spacer
173		Not used
174	606/2/75417/001	Thrust washer
175	606/1/75285/001	Thrust bearing
176	606/4/58174/001	Cushion ring
177	606/1/80481/001	Turntable spindle
178	606/2/79242/001	Retainer
179	606/4/44660/001	Spring
180		Not used
181	606/2/41218/007	Washer (3)
182	999/4/00852/022	Shakeproof washer (3)
183	999/4/30979/032	Screw (3)
184		Not used
185	606/1/80215/001	Modular mechanism complete
186	606/7/78675/001	Pinion bearing
187	999/4/01576/049	Screw
188	999/4/31029/036	Screw (4)
189	606/4/43217/001	Ball
190	606/7/44644/001	Spring
191	999/4/31029/047	Screw (8)
192		Not used
193	999/4/31029/019	Screw (4)
194	606/2/80078/001	Bush (4)
195	606/7/80077/001	Isolator foot (4)
196	606/1/80247/001	Bottom cover moulding with feet
197	999/4/30979/008	Screw (2)
198	999/4/31029/018	Screw (4)
199	999/4/30980/001	Cable tie (5)
200	999/4/31011/001	Fixing head (4)
201	408/4/51881/001	Main switch Type V3-92123-MF (2)
	501/1/61407/003	Loom complete with microswitches (U.S.A. and Canada)
	501/1/61407/005	Loom complete with microswitches (U.K. and Europe)
202		Part of 204
203	999/4/30979/006	Screw (2)
204	501/1/61449/001	Motor type MHN5P2RDA
205		Not used
206	501/1/61401/001	Mounting plate and transformer
207	405/SC/17128/003	Cover
208	501/1/61440/001	Mounting plate with transformer and motor 115V 60Hz (U.S.A. and Canada)
	501/1/61440/002	Mounting plate with transformer and motor 230V 50Hz (U.K. and Europe)
209	999/4/30975/001	Screw (3)
210	606/7/80102/001	Motor grommet (3)
211	606/2/41218/026	Washer (3)
212	999/4/00431/007	Spring clip (3)
213	999/4/01668/034	Screw (2)
214	501/1/61450/001	Motor pulley
215	408/4/51883/001	Speed switch Type V3-92101-MF
216	999/4/31029/017	Screw (4)
217	419/1/41478/001	Printed circuit board
218		Not used
219	702/1/26563/001	L.E.D. assembly
220	999/4/31029/016	Screw (6)
221	606/2/41218/009	Washer (6)
222	606/2/80460/001	Unit plate moulding
223	606/7/80072/001	Pitch control trim
224	999/4/30988/001	Clip (2)
225	606/7/80074/001	Knob – pitch control
226	606/1/80246/001	Single record spindle
227	606/7/80131/001	Turntable
228	606/7/80106/001	Cartridge setting gauge
229	606/7/80098/001	Turntable mat
230	606/1/79250/001	Multiple-play record spindle
231	606/7/78243/001	Capsule of lubricating oil
232	606/4/72698/001	45 rev/min record adaptor
233	606/1/80917/002	Top cover complete

## Circuit diagram – mains supply connections

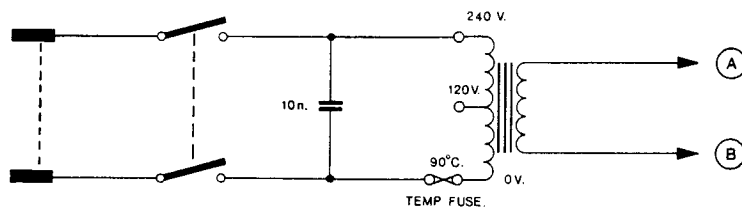

High range 240V

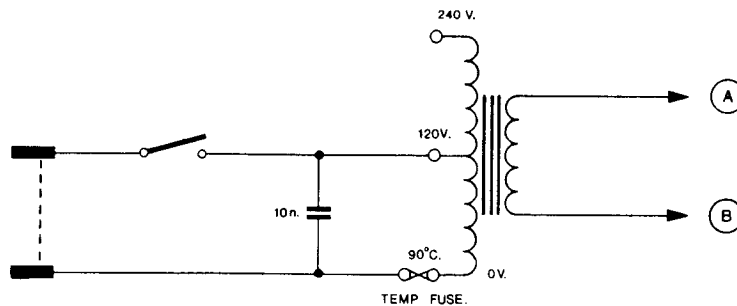

Low range 120V

**Note:** Loom screen sleeve ground wire taken from position adjacent to power socket to shield attachment screw at the Phono and DIN outlet panel (29).

# Garrard Model GT-35 – circuit diagram control and strobe electronics

## Strobe circuit

The full wave rectified signal from D7 and D8 supplies the triggering pulses for Tr2 at twice mains frequency. The CR network comprising R15, R17 and C15 controls the length

of the trigger pulse for Tr3 and has been arranged to give a duty cycle of approximately 7:1. R13 and R18 are used to limit the current through the L.E.D.

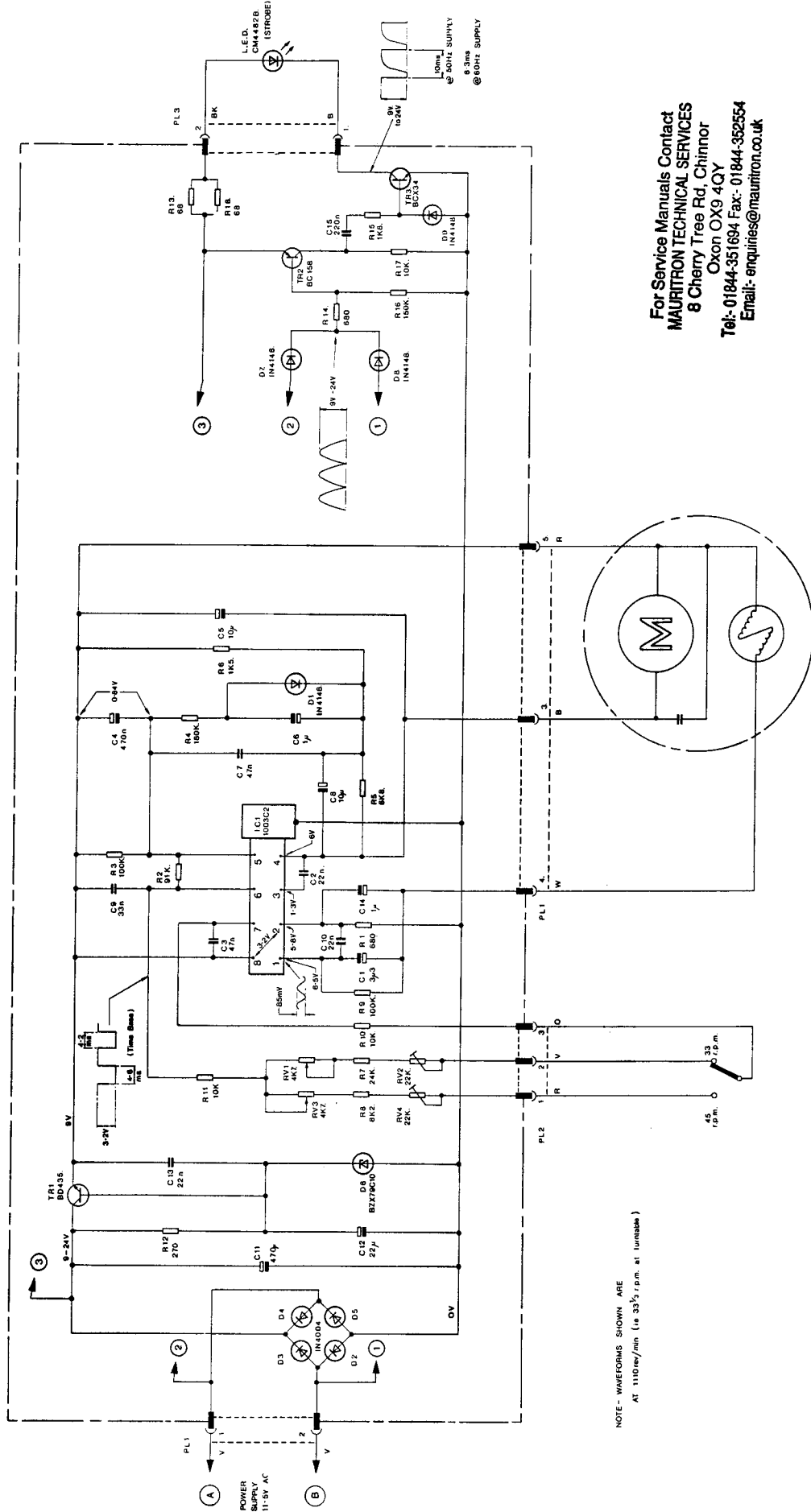

NOTE - WAVEFORMS SHOWN ARE AT 110rev/min (ie 33 1/3 r.p.m. at 1 rev/sec)

For Service Manuals Contact  
**MAURITRON TECHNICAL SERVICES**  
 8 Cherry Tree Rd, Chinnor  
 Oxon OX9 4QY  
 Tel: 01844-351694 Fax: 01844-352554  
 Email: enquiries@mauritron.co.uk



# Servicing – fault diagnosis – cause – remedy

It must be borne in mind that many faults, real and apparent, can be caused by incorrect installation, wiring or operation. They can also be attributed to warped, damaged or dirty records, faulty associated equipment or damage suffered as a result of rough handling in transit.

Reference numbers in the following charts stated in brackets, thus (50), are those of corresponding parts on the exploded view diagram.

As previously stated, before servicing or making adjustments, disconnect the power supply wherever practicable.

Remove headshell with cartridge, or protect stylus, secure pickup arm on its rest wherever practical.

When the pickup arm is secured to the rest, it must NEVER be in the manually cued up or automatically lifted position. This may result in permanent distortion of the rubber insert (101) in the lifting platform (102).

## Audio problems

### Symptom

No sound on one or more channels, or only low volume sound.

### Cause

- 1 Pickup cartridge, amplifier or speakers faulty.
- 2 Connections at the pickup head faulty. Pickup arm leads or audio connections at DIN and phono outlet faulty.
- 3 Incorrect amplifier input selected.
- 4 Cartridge not compatible with amplifier (low volume both channels).

### Remedy

- 1 Check by substitution and interchanging channel connections. Repair or replace as appropriate.
- 2 Disconnect cartridge and carry out continuity checks on leads and connectors. Disconnect head shell and carry out continuity checks on arm leads and connectors. Check connections at panel.
- 3 Select input with sufficient gain for cartridge fitted.
- 4 Replace cartridge with correct type.

Sound distorted, possibly as a result of pickup mistracking.

- 1 Insufficient or excessive stylus force.
- 2 Worn, chipped or incorrect stylus tip.
- 3 Accumulation of dust around the stylus tip.
- 4 Pickup cartridge insecurely fixed or out of position.
- 5 Incorrect amplifier input selected.
- 6 Tight pickup leads at back of pickup arm.
- 7 Heel of cartridge touches record.
- 8 Acoustic feedback.
- 9 'Cue' control not moved to fully  $\nabla$  .
- 10 Unit not mounted level.
- 11 Plastic dust cover cleaned with dry cloth, so that static electricity attracts pickup arm.
- 12 Pickup arm bearings tight.

- 1 Reset stylus force to cartridge manufacturer's recommendations. See 'Adjustments'.
- 2 Examine stylus tip microscopically and check condition of stylus bar. Fit new stylus if necessary.
- 3 Clean with a camel-hair brush. See 'Routine maintenance'.
- 4 Reset cartridge using gauge, tighten fixing screws. See 'Adjustments'.
- 5 Select input with the correct gain for cartridge.
- 6 Relieve tension, leaving leads slack. Check that leads are not caught in moving parts of mechanism.
- 7 Fit tilt wedge, deep end forward, between top of cartridge and underside of headshell.
- 8 Check that turntable is not too close to speakers. Unit must be free to move on its resilient feet.
- 9 Move control to fully forward,  $\nabla$  .
- 10 Check with spirit level. Stand base on a horizontal surface.
- 11 Wipe the cover with a clean damp cloth.
- 12 Check horizontal freedom of pivots (vertical motion) (16) when the arm is pushed inwards against spring loading. This is required to be carefully done to avoid cracking the jewel in the pivot screw (16). Fit new pivot screw if necessary. Check the vertical pivot assembly for freedom of movement. Check side forces on the arm measured at the stylus. See 'Specifications'.
- 13 Check pickup lever is not bent. Check clearance between pickup lever and bias plate (41). Replace pickup lever, improve clearance by bending corner of bias plate if necessary.
- 14 Reset bias control. Check bias mechanism for correct functioning. Replace spring as necessary.
- 15 Check height, and reset. See 'Adjustments'.  
**Note:** When adjusting the height, great care must be taken to ensure that the top of the headshell does not hit the underside of a record on the multi-play record spindle, during the automatic change cycle and manual cue.

For Service Manuals Contact  
MAURITRON TECHNICAL SERVICES  
8 Cherry Tree Rd, Chinnor  
Oxon OX9 4QY  
Tel: 01844-351694 Fax: 01844-352554  
Email: enquiries@mauritron.co.uk

Symptom	Cause	Remedy
Hum.	<ol style="list-style-type: none"> <li>1 Grounding lead(s) disconnected.</li> <li>2 'Ground loop' in pickup wiring system.</li> <li>3 Faulty audio connections, such as plug, pickup head and socket. Damaged pickup leads, or phono leads.</li> <li>4 Proximity of audio and AC power leads.</li> <li>5 Polarity of mains AC power supply connections at the plug.</li> </ol>	<ol style="list-style-type: none"> <li>1 Reconnect.</li> <li>2 No part should be connected to ground by more than one route. If a second route exists, including wire on phono leads, disconnect it.</li> <li>3 Check security of leads to pickup cartridge at headshell (1) and arm socket (79), check correct function of connecting pins in arm socket. Carry out continuity tests on leads and connectors. Replace arm sleeve (79) or phono lead as necessary.</li> <li>4 Reroute leads, checking that pickup leads do not hang in long loops.</li> <li>5 Reverse connections at the plug.</li> </ol>
Rumble.	<ol style="list-style-type: none"> <li>1 Turntable spindle and/or turntable hub bearings dry or dirty.</li> <li>2 Turntable thrust bearings dry, dirty or damaged.</li> <li>3 Unit resilient mounting feet too stiff or distorted.  Motor and transformer plate grommets not resilient.</li> <li>4 Rumble on particular records only.</li> <li>5 Excessive AC ripple in regulated DC motor supply.</li> <li>6 Tight isolator (9) at the back of the pickup arm.</li> </ol>	<ol style="list-style-type: none"> <li>1 Remove turntable clip (169) and hub (170), clean and relubricate. See 'Maintenance'.</li> <li>2 <b>GT-35</b> Remove turntable, hub (170), pinion (161) and drive belt (153) and spacer (172) to check condition of thrust washers (174) and thrust bearings (175). Clean and relubricate or replace as necessary. See 'Maintenance'. <b>GT-35P</b> Remove turntable clip (169), hub (170) and thrust housing (174) from hub. Examine, clean and relubricate, or replace spindle housing (177) and/or thrust housing as necessary.</li> <li>3 Check feet and unit freedom of movement on feet, check feet not bottoming. Replace feet as necessary.  Check motor and transformer plate hangs freely and level in its rubber mountings.</li> <li>4 Recorded rumble. Use amplifier's rumble filter, if fitted. Otherwise no cure.</li> <li>5 Using a decoupling capacitor (200µF), measure the AC voltage across red motor lead and zero volts line. It should not exceed 20mV r.m.s. Check electrolytic capacitors by substitution and replace as necessary.</li> <li>6 Back off screw just sufficiently to increase compliance of isolator. Replace screw (modified).</li> </ol>
Wow and flutter.	<ol style="list-style-type: none"> <li>1 Recorded wow and flutter. Record hole off-centre or enlarged.</li> <li>2 Warped record in a stack slipping (GT-35 only).</li> <li>3 Record label paper or moulding 'flash' in centre hole binding on record spindle (GT-35 only).</li> <li>4 Lubricant on turntable drive belt (171).</li> <li>5 Automatic mechanism drive belt (153) tight or slack.</li> <li>6 Incorrect motor pulley height.</li> <li>7 Damaged motor spindle.</li> </ol>	<ol style="list-style-type: none"> <li>1 No cure.</li> <li>2 Play record singly.</li> <li>3 Carefully ream hole with a pencil or penknife.</li> <li>4 Clean belt (171), turntable hub (170) and motor pulley (214).</li> <li>5 Reset tension. See 'Adjustments'.</li> <li>6 Slacken both fixing screws and reset pulley (214). See 'Service notes – adjustments'.</li> <li>7 Fit new motor.</li> </ol>
Radio or television sound heard through speakers.	<ol style="list-style-type: none"> <li>1 Radio frequency signals detected by amplifier.</li> </ol>	<ol style="list-style-type: none"> <li>1 This trouble is seldom caused by the record player, providing grounding and audio connections have been made securely and the audio connecting lead is kept short. The amplifier manufacturer should be consulted in persistent cases.</li> </ol>



# Mechanical problems

Symptom	Cause	Remedy
Pickup arm will not leave rest (GT-35 only).	<ol style="list-style-type: none"> <li>Pickup arm lifting height or height restriction adjustment upset. Arm not balanced before setting stylus force.</li> <li>Pickup arm not released from rest.</li> <li>Excessive stylus force.</li> <li>Mechanism drive belt (153) broken.</li> <li>Mechanism friction too low.</li> <li>'Auto' operating control knob not fully rotated to the end of movement, or not held in 'Auto' position long enough to allow trip pawl (127) to be picked up by the turntable drum striker.</li> <li>Friction between the pickup arm tube and the insert (101) in the lifting platform is too high.</li> </ol>	<ol style="list-style-type: none"> <li>Reset. See 'Adjustments'.</li> <li>Move locking catch to free position.</li> <li>Check and reset stylus force. See 'Adjustments'.</li> <li>Fit new belt.</li> <li>Check friction and reset. See 'Service notes'.</li> <li>Turn control knob to fullest extent of its travel and hold in that position for a few moments.</li> <li>Check is not too high. Maximum value of side force due to friction is 4g. See 'Service notes'.</li> </ol>
Pickup arm lands too far in or out on the record (GT-35 only).	<ol style="list-style-type: none"> <li>Pickup arm lowering position out of adjustment.</li> <li>Record speed/size selector incorrectly set.</li> </ol>	<ol style="list-style-type: none"> <li>Reset. See 'Adjustments'.</li> <li>Move control to 33 or 45 for 12in or 7in respectively.</li> </ol>
Pickup arm continuously lands on record and immediately returns to its rest (GT-35 only).	<ol style="list-style-type: none"> <li>Automatic trip mechanism binding.</li> </ol>	<ol style="list-style-type: none"> <li>Check freedom of movement of the friction and cycle levers (129) and (136). Check condition of impulse link (157). Replace as necessary.</li> </ol>
Pickup arm lowers too fast.	<ol style="list-style-type: none"> <li>Cueing rate requires adjustment.</li> <li>Lack of sufficient viscous damping fluid on cueing lifter (89).</li> </ol>	<ol style="list-style-type: none"> <li>Adjust nut (108) clockwise. See 'Dismantling main component assemblies'.</li> <li>Recharge cueing lifter spindle, using only Garrard fluid (part no. 606/1/71724/004). See 'Dismantling main component assemblies'.</li> </ol>
Pickup arm lowers on to record and jumps first few playing grooves (GT-35 only).	<ol style="list-style-type: none"> <li>Stylus lands at top of record groove guard rim and slides down it.</li> <li>Insufficient bias force applied.</li> </ol>	<ol style="list-style-type: none"> <li>Set lowering position inwards so that stylus lands at bottom of guard rim. See 'Adjustments'.</li> <li>Reset. See 'Adjustments'.</li> </ol>

## Additional faults – miscellaneous

Two records lowered at once (GT-35).	<ol style="list-style-type: none"> <li>Automatic record spindle damaged.</li> <li>Non-standard records.</li> <li>Record support platform position incorrect, or record clip (169) faulty (GT-35).</li> </ol>	<ol style="list-style-type: none"> <li>Check that both latches at top of spindle fall freely. Do not oil them. Fit a new spindle if necessary.</li> <li>If records are less than 1.35mm (0.053in) thick at their centre holes, play them singly.</li> <li>Make sure that the clip on the platform steadies a stack of records and that the platform supports the record stack at its edge. Reset the platform. Check tension in record clip spring functionally. See 'Adjustments'.</li> </ol>
Records fail to lower (GT-35).	<ol style="list-style-type: none"> <li>Automatic record spindle damaged.</li> <li>Moulding 'flash' or label paper in centre hole.</li> <li>Non-standard records.</li> <li>Record release lever (143) disengaged, or its controlling spring blade damaged.</li> <li>Record spindle seated incorrectly.</li> </ol>	<ol style="list-style-type: none"> <li>Remove the spindle and check that its record pushing pawl moves freely. Fit a new spindle if necessary.</li> <li>Ream hole carefully with a penknife. Do not enlarge it or distort it.</li> <li>Records with oversize centre hole, or more than 2.3mm (0.09in) thick at the centre. Play these records singly.</li> <li>Refit retaining circlip. Replace or fit new blade.</li> <li>Make sure that the turntable retaining clip (169) is fitted securely and the record spindle fully down.</li> </ol>

Symptom	Cause	Remedy
Unit fails to trip automatically at the end of the record side.	1 Automatic trip binding.	1 Check freedom of friction and cycle levers (129) and (136).
	2 Mechanism drive belt broken.	2 Replace drive belt.
Unit fails to switch off automatically.	1 Programme lever (166) binding.	1 Check that the programme lever pivots freely and that the selector link (65) can slide up and down.
	2 'Mode' selector moved to 'Off' position during automatic cycle.	2 Check that the selector link is not disengaged with programme lever roller (166). Re-engage roller.
'Mode' selector cannot be re-programmed.	1 Selector moved to 'Off' position during the automatic cycle.	1 Rotate the turntable hub a few times in a clockwise direction to release the selector.

# Modular mechanism – function and operation

The modular mechanism provides the means of automatically lowering each record of a stack of up to five, moving the pickup arm off the rest, swinging the arm inwards and lowering its pickup stylus on to the record at the beginning of the recorded grooves and lifting off the record at the end of the recording, swinging the arm outwards to the rest position and repeating the cycle whilst there are records on the record spindle to be played. At the end of play of the last record, the arm will stay on its rest and the unit will switch off.

Facility is also built into the mechanism to repeat play the last of the stack of records, or a single record on the turntable platter indefinitely.

## Condition of unit

Set up as described in the preceding text, page 3, on a level surface so that the lateral forces acting on the pickup arm do not interfere with the tracking performance. A stack of records of up to five in number is placed on the automatic multi-play record spindle, resting on the support platform and retained by the record steady. The pickup arm rest clip is released and the cartridge stylus guard removed or swung to expose the stylus.

## Control operations

- 1 Select speed for  $33\frac{1}{3}$  rev/min by rotating the control knob which is attached to a control lever (59) and cams the speed micro-switch (201) plunger in to change from 45 to  $33\frac{1}{3}$  rev/min. At the same time the control lever swings the selector control lever (66) which pivots about a pin on the control plate (60) and moves the selector link in to a position where it will arrest the selector lever (117) and provide the precise pickup arm lowering position at the beginning of the run-in grooves of a 12in record.
- 2 Select the mode control at 'Automatic' which moves the programme lever (166) via a programme actuating lever (57) and a control lever (59). At the same time the control lever cams the mains power supply micro-switch plunger to switch the power and turntable drive on.
- 3 Impulse the mechanism by turning the control knob to 'Start' and holding it in the fully turned position for a few seconds. With the drive on as in 2, the trip pawl (127) on the main cam (131) is picked up by the striker on the pinion (161) which is being rotated by the drive belt from the turntable. The control knob is connected to the trip friction lever (129) by an impulse link (157) which swings inwards to pivot the trip pawl to its outermost position for collection by the pinion.

## Sequence of movements of the levers

- a The pin on the cam lever (158) swings into the 'Sense' detent of the main cam as it rotates and the tail end of the cam lever moves past the trailing lug on the programme lever, without collecting it.
- b The pickup arm is lifted via the lifting blade (119) in contact with the cam rise.
- c The cam lever reverses as its follower moves outwards with the cam form, and the phosphor bronze pin on the cam lever moves the pickup actuating lever outwards to collect the arm in the rest position.
- d Immediately prior to the maximum out position of the cam lever, the friction assembly, incorporated on the cam lever, is reset by contact with a pin attached to the mechanism casting. Simultaneously, the cam lever releases a record on its spindle via the release lever (143) which is connected to the cam lever.
- e Also at this point in the cycle, the selector lever (117) moves outwards as its follower drops inwards, at the gap in the cam form, under spring tension. The catch face arm of the selector lever is moved out to contact the tail of the selector rod which predetermines the stylus set-down position. The other arm of the selector lever carries the inter-selector lever (115) inwards into the path described by the selector pin on the pickup lever.
- f Movement of the cam lever is then reversed by the cam form, such that the friction assembly on the cam lever carries the pickup arm inwards from its rest, until the selector pin on the pickup lever makes contact with the step on the inter-selector lever.
- g With the pickup arm movement arrested by the inter-selector lever, the cam lever moves inwards and the friction assembly is disengaged from the pin on the pickup lever.
- h At this point the inter-selector lever is moved from the path described by the selector pin on the pickup lever, as the selector lever follower engages the cam form again. Also the spring tail (141) engages with the leading lug on the programme lever, rotating it such that the trailing lug on the programme lever is moved into the path described by the cam lever tail.
- j The pickup arm is then lowered to place the stylus on to the record at the run-in grooves, as the lifting blade moves down the face cam and the main cam then moves into the index position under the influence of the spring-tensioned index lever (154).

k At the end of play of the record side, the pickup lever initiates the cycle as the stylus moves quickly through the run-out grooves of the record, and the trip pawl is engaged by the striker on the rotating pinion. At this point, the pin on the cam lever moves into the 'Sense' detent of the cam as described in 'a', but since there are records still on the record spindle, the tail of the cam lever does not swing in far enough to pick up the trailing lug of the programme lever and move it on where it will be picked up by the spring tail on the cam and the unit will be switched off.

The mechanism will be recycled whilst there are records on the spindle and the preceding description of the movements will continue to apply.

When the last record has been lowered and recording played, and the cycle has been initiated by the engagement of the trip pawl by the rotating pinion, the pin on the cam lever moves into the 'Sense' detent on the cam. As the trailing lug on the programme lever has been positioned into the path of the tail of the cam lever, during the preceding cycle, it is picked up and the programme lever rotated such that the centre lug is moved into the described path of the spring tail of the main cam and the tail of the selector rod is lowered below the path of the selector lever.

l The cam lever reverses and moves the lifted pickup arm outwards to the rest at which point the friction assembly is reset as described in 'd' and the selector lever moves inwards against the cam form.

m Because the selector rod tail has been lowered by action of the programme lever rotation, the selector lever moves fully inwards over the top of the selector rod, allowing the rest stop position of the inter-selector lever to move into the path of the selector pin on the pickup lever.

n The pickup lever is pulled inwards with the selector pin on the pickup lever engaging with the rest-stop face of the inter-selector lever, and the friction assembly on the cam lever is disengaged. At this point the inter-selector lever is removed from the path of the selector pin on the pickup lever.

o Immediately prior to the cam completing its rotation and lowering the pickup arm under the action of the index lever indexing the main cam, the middle lug of the programme lever is contacted by the spring tail of the cam, causing it to rotate and register the switch-off of the turntable drive and power.

p To continuously repeat the auto play of the last record of the stack, or a single record on the turntable platter, the programme lever is rotated further by the mode control such that the tail of the spring on the cam, or the tail of the cam lever does not make contact with the programme lever during the cycle of the main cam.

## Routine maintenance

Careful design has reduced the need for maintenance to a minimum, but attention to the following points will prolong trouble-free listening.

It will be noted that only the turntable and its spindle require lubrication.

### The pickup cartridge stylus

If the stylus tip gathers dust, sound quality will suffer.

Brush the dust away with an artist's camel-hair brush, working only from the back of the stylus towards the front to avoid bending it. Do not use solvent without the cartridge manufacturer's approval. Examine the stylus tip under a microscope of 50X magnification for wear periodically, as the cartridge manufacturer advises. A worn or chipped stylus tip damages records permanently.

### The turntable mat

Periodically remove the mat and clean it with a soft brush or a slightly moistened sponge. It is made of conductive rubber to minimise the effect of static electricity on records.

### The drive system

Once a year, remove the turntable, belt and drive drum (see later instructions). Care must be taken to avoid contaminating the rubber drive belt with oil. Clean the drive drum bearing sleeve with a lint-free cloth. At the same time remove the turntable spindle thrust bearing and washers (GT-35 only).

Before reassembly (see later instructions), apply a thin film of lubricating oil, part no. 606/7/78243/001, or similar grade sewing machine oil, to the thrust bearing and washers (GT-35 only), turntable spindle and drive drum bearing sleeve. Also

check the condition of the drive belt and fit a new one if in doubt.

**Note:** If the driving surfaces of the drive drum and belt become contaminated with lubricant, wipe them with a clean lint-free cloth moistened with alcohol.

### To remove the turntable drive drum

- 1 Remove rubber mat.
- 2 Remove the turntable platter.
- 3 Detach the drive belt from the motor pulley and drive drum.
- 4 Rotate the drive drum to align the gap in the spindle housing (168) with the flat of the turntable drum spindle, withdraw the record spindle and slide out the hub retaining wire clip.
- 5 Lift off the drive hub.

The spacer (172), thrust washers (174) and thrust bearing (175) can now be lifted off the spindle for cleaning and examination for defects (GT-35 only).

The GT-35P has none of these latter parts, fitted to the spindle. The thrust is taken by a hardened and lapped thrust disc in the spindle housing (168) which runs on a precision bearing ball attached to the top of the turntable drum spindle.

For assembly of the drive drum, thrust washers and bearings after cleaning and lubricating, follow the preceding instructions in reverse order.

For Service Manuals Contact  
MAURITRON TECHNICAL SERVICES  
8 Cherry Tree Rd, Chinnor  
Oxon OX9 4QY  
Tel:- 01844-351694 Fax:- 01844-352554  
Email:- enquiries@mauritron.co.uk

# Model GT-35P

## belt drive single player

## servicing information

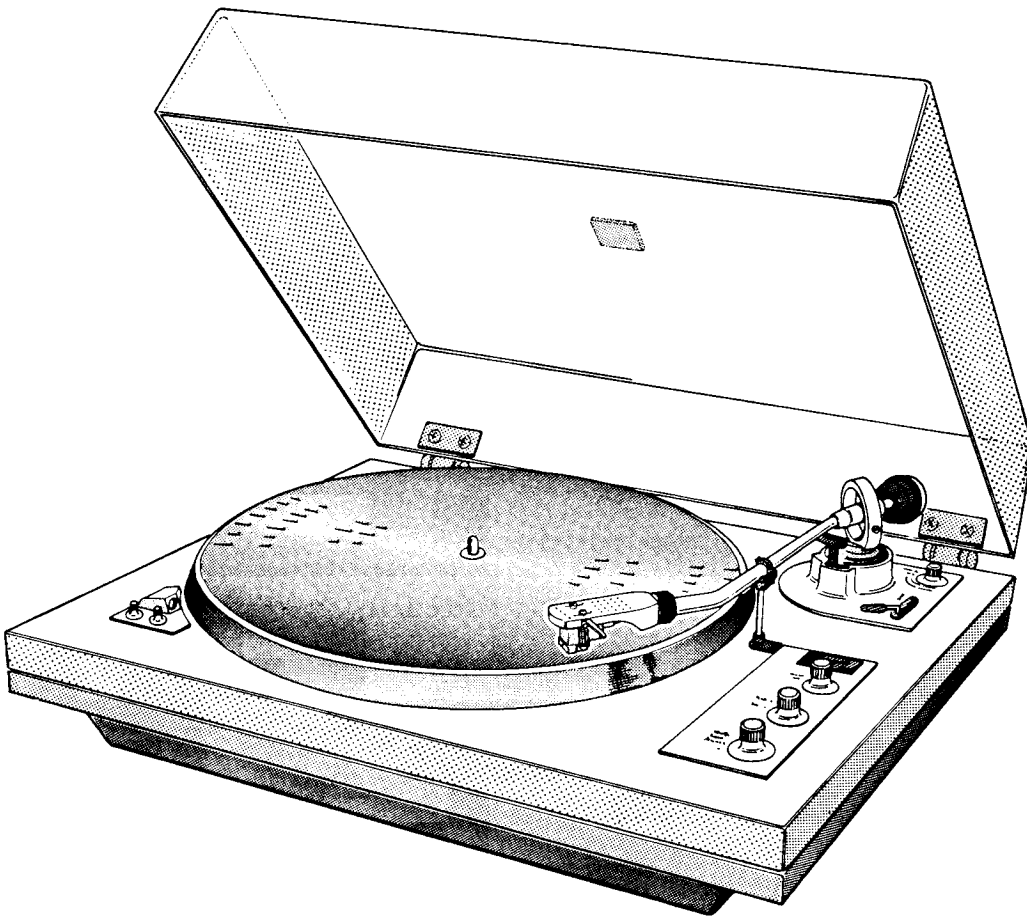

### Model GT-35P

Information in this part is exclusive to the GT-35P and is a supplement to the GT-35 text.

It must be noted that the reference numbers shown in the following exploded view and spare parts list are different from those of the GT-35, and care should be taken to quote the correct part number in any query.

# General information

The GT-35P is the single play version of the GT-35 (changer). It is similar in appearance to the GT-35 in most respects. A lower profile is obtained by the use of a low dust cover.

The GT-35P is a semi-automatic integrated player with a trip, lift and return to the rest, pickup arm facility. The playing facilities, apart from the manual control of the pickup arm and the playing of a stack of records, are the same as the GT-35.

The GT-35P is also made with the alternative base plinths in simulated wood finishes and moulded style.

Low and high range (110V/125V and 220V/240V respectively) are made for world-wide use.

As for the GT-35, it is important to quote the eight figure code number of the unit (commencing 80035/---) in all enquiries.

# Specifications

The specifications for the GT-35P are identical to those of the GT-35 with the following exceptions:

Dimensions 450mm × 360mm × 156mm (W × D × H).  
17.7in × 14.15in × 6.14in.

Weight 6.225kg (13.79lb).

# Accessories – packed

The following accessories will be stowed in the poly-pack cavities:

- 1.1 Headshell assembly. If a cartridge is not fitted, screws and nuts etc. for fixing one are provided.
- 1.2 A gauge to align the cartridge in the headshell for optimum tracking.
- 1.3 A 45 rev/min single hole record adaptor.
- 1.4 Pickup arm counterbalance weight.
- 1.5 A capsule of lubricating oil for routine maintenance.

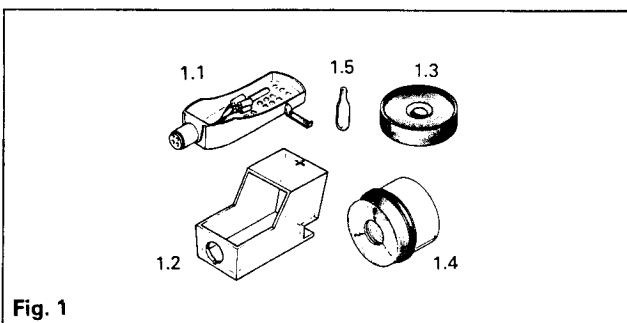

Fig. 1

# Installation

The directions for the unpacking, setting up, fitting a cartridge, adjusting the stylus force and bias compensator force, phono connections and power supply connections are the same as stated for the GT-35.

# To play a record

The method used to play a record is similar to that used for the GT-35 and described in its text.

The GT-35P has an integral record spindle which rotates with the turntable.

At the end of play of the record, the pickup arm will lift and return to its rest and the unit will switch off automatically.

# Service notes – adjustments

The chapter contained in the GT-35 text regarding Service Notes – Adjustments contains all the details required for the GT-35P, with the following exceptions.

Since the pickup arm does not set down on the record automatically, the paragraphs appertaining to lowering position, record support platform position, release lever setting and mechanism friction check – pickup arm movement are not applicable.

# Turntable bearings

The suspension of the turntable in terms of journal and thrust bearings differ considerably from the method employed on the GT-35.

The unit being a single player, has no need for a hollow turntable spindle. Consequently, a 6mm diameter solid spindle is fitted to the spindle housing with the use of a shouldered brass bush pressed into the standard size hole in the housing casting. The top end of the spindle is recessed to house a precision steel ball bearing which is free to rotate in the spindle and is retained by a stabbing operation.

The thrust housing (195), attached to the turntable drive drum contains a flat, hardened and lapped thrust disc on which the ball in spindle runs.

Care must be taken in the handling of the turntable during assembly to the drive hub, to prevent the turntable from dropping accidentally which may result in the 'brinelling' of the thrust disc by the ball in the spindle. When assembling the drive drum to the spindle check the cleanliness of both spindle and brass bearing in the drive drum – lubricate.

For Service Manuals Contact  
**MAURITRON TECHNICAL SERVICES**  
8 Cherry Tree Rd, Chinnor  
Oxon OX9 4QY  
Tel:- 01844-351694 Fax:- 01844-352554  
Email:- enquiries@mauritron.co.uk

# Exploded view

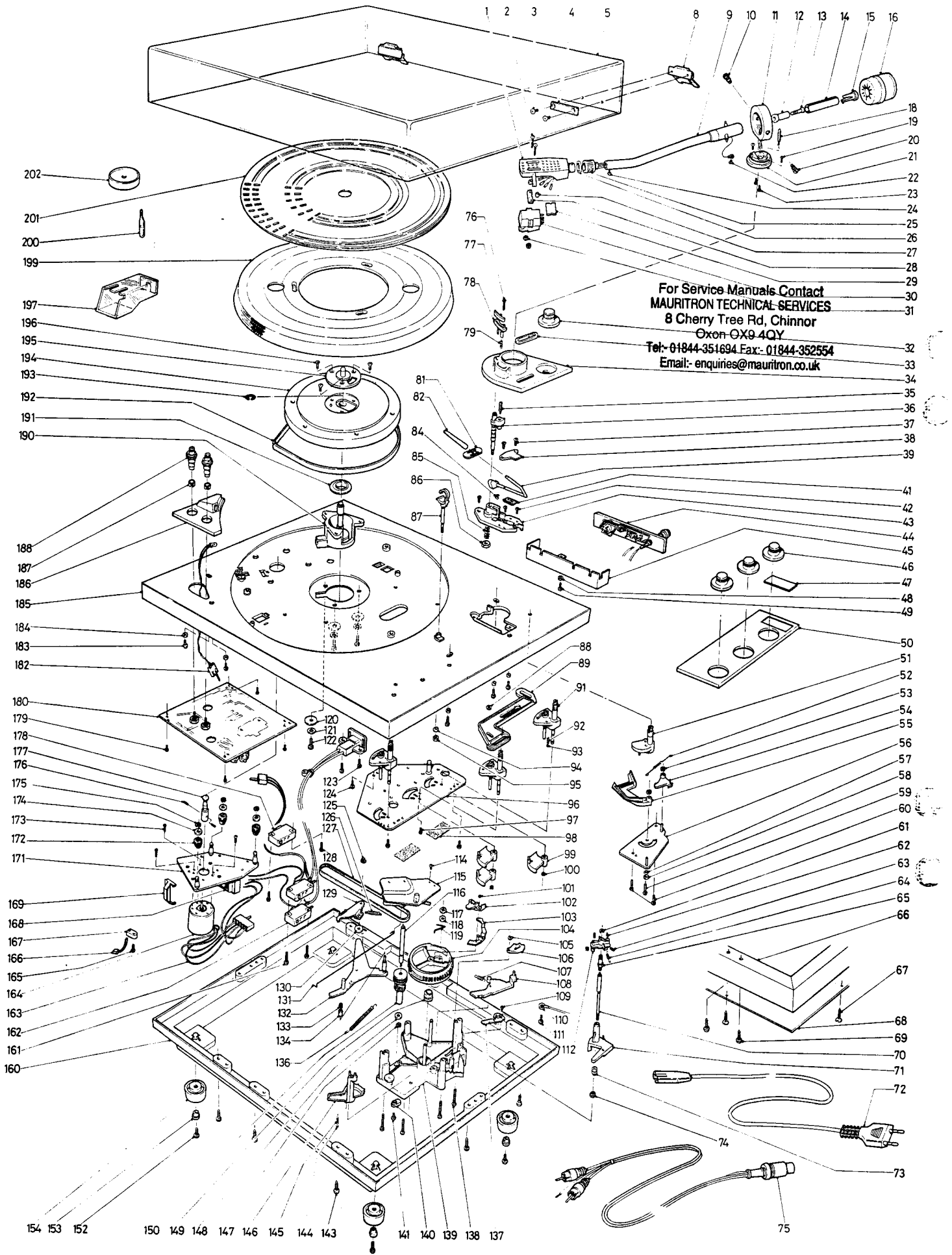

# Spare parts list for exploded view

Ref. No.	Garrard Part No.	Description	Ref. No.	Garrard Part No.	Description
1	606/1/80570/001	Type H1 pickup head	79	606/7/67047/001	Spring
	606/1/80627/001	Type H1 pickup head, with fixing kit	80		Not used
2		M2.5 screw - length to suit cartridge	81	606/7/80075/001	Cueing trim
3	999/4/31019/001	Screw (4)	82	606/7/80504/001	Cue lever knob
4	606/7/80199/001	Clamp plate (2)	83		Not used
5	606/1/80917/001	Top cover complete	84	999/4/00431/036	Spring clip
6		Not used	85	606/7/45017/001	Spring
7		Not used	86	606/2/80256/001	Nut
8	606/7/80174/001	Hinge (2)	87	606/1/80233/001	Pickup rest
9	606/1/80216/001	Pickup arm tube with gimbal	88	999/4/30993/001	Fastener
10	606/7/80193/001	Pivot screw	89	606/7/80093/001	Programme actuating lever
11	606/1/80231/001	Gimbal with support	90		Not used
12	606/7/78475/001	Isolator	91	606/1/80222/001	Control moulding
13	606/2/78494/001	Screw	92	606/7/44644/001	Spring
14	606/2/80142/001	Tube	93	606/7/80171/001	Ball
15	606/7/78474/001	Tensioner	94	999/4/00852/008	Washer
16	606/1/80228/001	Counterbalance weight	95	991/4/01911/004	Nut
17		Not used	96	606/1/80217/004	Control plate with mouldings
18	606/2/80183/001	Restrictor screw		606/1/80238/001	Control plate only
19	999/4/31039/001	Screw (2)	97	999/4/30979/001	Screw
20	606/7/80194/001	Pivot screw	98	606/7/80495/001	Insulator pad (2)
21	606/2/80204/001	Gimbal support	99	606/7/80507/001	Switch lever
22	999/4/01145/002	Screw	100	606/4/79526/001	Spring clip
23	999/4/00411/052	Screw (2)	101	999/4/00431/002	Spring clip
24	999/4/02077/039	Screw	102	606/7/80400/001	Trip pawl
25	606/1/80237/001	Pickup arm sleeve, with grip ring and leads	103	606/7/80399/001	Trip friction lever
26	606/2/41235/002	Washer	104	606/1/80398/001	Cam
27	606/2/80673/001	Spacer	105	999/4/00481/002	Spring clip
28	606/2/75392/001	Tilt wedge	106	606/7/80206/001	Inter selector lever
29	606/2/80696/001	Auxiliary weight	107	606/7/44668/001	Spring
30		Cartridge (please state type)	108	606/7/78672/001	Selector lever
31	606/2/78480/001	Nut (2)	109	999/4/30979/002	Screw
32	606/7/80073/001	Control knob	110	501/1/60343/153	Earth lead
33	606/7/80208/001	Lever surround	111	999/4/30979/001	Screw
34	606/1/80232/001	Pickup arm trim, with surround	112	606/1/80471/001	Overload casting, with screws
35	606/2/80156/001	Adjusting screw	113		Not used
36	606/1/80207/001	Cueing lifter	114	999/4/30976/002	Screw
37	999/4/30979/003	Screw (2)	115	606/1/80236/001	Support plate, with cycle lever
38	606/2/80124/001	Cueing plate	116	606/2/78628/001	Pinion spindle
39	606/1/80240/001	Cue lever	117	999/4/30993/002	Fastener
40		Not used	118	606/2/41234/002	Washer
41	606/2/80688/001	Friction pad	119	606/7/44643	Spring
42	999/4/31029/017	Screw (2)	120	606/2/41218/007	Washer (3)
43	606/1/80241/001	Cueing assembly, with lifter and lever	121	999/4/00852/022	Shakeproof washer (3)
44	606/1/80485/001	Phono and DIN output panel	122	999/4/30979/032	Screw (3)
45	606/2/80129/001	Phono socket shield	123	999/4/31029/018	Screw (2)
46	606/7/80073/001	Control knob (3)	124	999/4/31029/017	Screw (3)
47	606/2/80500/004	Name plate	125	999/4/02654/001	Spring clip
48	606/4/00852/008	Washer	126	606/4/44699/001	Index lever spring
49	999/4/31029/017	Screw	127	606/7/78973/001	Drive belt
50	606/1/80476/004	Control trim with nameplate	128	999/4/30979/006	Screw (2)
51	606/7/80091/001	Bias cam	129	606/7/78670/001	Index lever
52	606/7/67043/001	Bias spring	130	606/2/41234/003	Washer
53	999/4/00431/046	Spring clip (2)	131	606/7/80172/001	Impulse link
54	606/7/80092/001	Bias cam follower	132	606/1/80243/001	Cam lever
55	606/7/80203/001	Bias lever	133	606/7/67048/001	Wire clip
56	606/1/80474/001	Bias assembly with lever, cam and follower	134	606/2/80719/001	Roller
57	606/5/42561	Spring washer	135		Not used
58	606/2/41234/002	Washer	136	606/7/44690/001	Spring (cam lever)
59	999/4/01515/020	Screw (1)	137	606/7/79879/001	Lifting blade
60	999/4/30129/017	Screw (2)	138	999/4/31029/036	Screw (4)
61	999/4/01167/004	Spring clip	139	606/1/80488/001	Modular mechanism complete
62	606/2/78476/001	Nut (2)	140	606/7/78675/001	Pinion bearing
63	991/4/01665/039	Screw (2)	141	999/4/01576/049	Screw
64	606/4/44448/001	Overload spring	142		Not used
65	606/7/80197/001	Vertical jewel bearing	143	999/4/31029/047	Screw (8)
66	606/7/80179/001	Plinth (walnut style)	144	606/4/43217/001	Ball
	606/7/80179/002	Plinth (rosewood style)	145	606/7/44644/001	Spring
	606/7/80179/003	Plinth (teak style)	146	606/1/80573/001	Programme lever
67	999/4/00973/028	Screw (8)	147	999/4/00687/006	Spring clip
68	606/1/80218/001	Bottom cover with feet	148	606/2/41218/055	Washer
69	999/4/31029/049	Screw (8)	149	606/2/80321/001	Cueing damper
70	606/1/80235/001	Pickup spindle	150	606/1/80220/001	Pinion
71	606/1/80470/001	Pickup lever	151		Not used
72	606/1/80514/001	Line cord (U.S.A. and Canada)	152	999/4/31029/019	Screw (4)
	606/1/80515/001	Mains lead (U.K. - no plug)	153	606/2/80078/001	Bush (4)
	606/1/80518/001	Mains lead (with Europlug)	154	606/7/80077/001	Isolator foot (4)
73	606/2/80163/001	Collar	155		Not used
74	606/2/80143/001	Nut	156		Not used
75	606/1/80517/001	Audio connecting lead	157		Not used
76	606/2/80167/001	Screw	158		Not used
77	606/7/80086/001	Insert	159		Not used
78	606/1/80229/001	Lifting platform, with insert	160	606/1/80247/001	Bottom cover - dark grey moulding with feet
			161	999/4/30979/008	Screw (8)

# Spare parts list for exploded view

Ref. No.	Garrard Part No.	Description			
162	408/4/51881/001	Main switch (2) Burgess V3 - 92123 - MF	179	999/4/31029/017	Screw (4)
163	501/1/61407/003	Loom complete with microswitches (U.S.A. and Canada)	180	419/1/41478/001	Printed circuit board
	501/1/61407/005	Loom complete with microswitches (U.K. and Europe)	181		Not used
164	501/1/61449/001	Motor, type MHN5P2RDA	182	702/1/26563/001	L.E.D. and lead assembly
165	999/4/31029/018	Screw (4)	183	999/4/31029/016	Screw (6)
166	999/4/30980/001	Cable tie (5)	184	606/2/41218/009	Washer (6)
167	999/4/31011/001	Fixing head (4)	185	606/7/80065/001	Unit plate moulding
168	501/1/61401/001	Motor plate, with transformer	186	606/7/80072/001	Control trim
169	405/5C/17128/003	Cover	187	999/4/30988/001	Clip (2)
170		Not used	188	606/7/80074/001	Knob (pitch control) (2)
171	501/1/61440/001	Motor plate with transformer and motor 115V, 60Hz (U.S.A.)	189		Not used
	501/1/61440/002	Motor plate with transformer and motor 230V, 50Hz (U.K. and Europe)	190	606/1/80479/001	Turntable spindle
172	606/7/80102/001	Motor grommet (3)	191	606/7/80502/001	Spacer
173	999/4/30975/001	Screw (3)	192	606/7/76992/001	Drive belt
174	606/2/41218/026	Washer (3)	193	999/4/31033/009	Spring clip
175	999/4/00431/007	Spring clip (3)	194	606/1/80213/001	Turntable hub complete
176	999/4/01668/034	Screw (2)	195	606/1/80239/001	Thrust housing
177	501/1/61450/001	Motor pulley	196	999/4/31031/019	Screw (3)
178	408/4/51883/001	Speed switch - 92101-MF	197	606/7/80106/001	Cartridge setting gauge
			198		Not used
			199	606/7/80131/001	Turntable
			200	606/7/78243/001	Capsule of lubricating oil
			201	606/7/80098/001	Turntable mat
			202	606/4/72698/001	45 rev/min record adaptor

## Amendments and notes

For Service Manuals Contact  
**MAURITRON TECHNICAL SERVICES**  
 8 Cherry Tree Rd, Chinnor  
 Oxon OX9 4QY  
 Tel:- 01844-351694 Fax:- 01844-352554  
 Email:- enquiries@mauritron.co.uk

Garrard Engineering Limited,  
 Newcastle Street,  
 Swindon, Wiltshire, England.  
 Telephone: (0793) 35381.  
 Telex: 44271.

**Garrard**  
 A Plessey Company

80030/80035/002 Issue 1  
 Printed in England