

Garrard

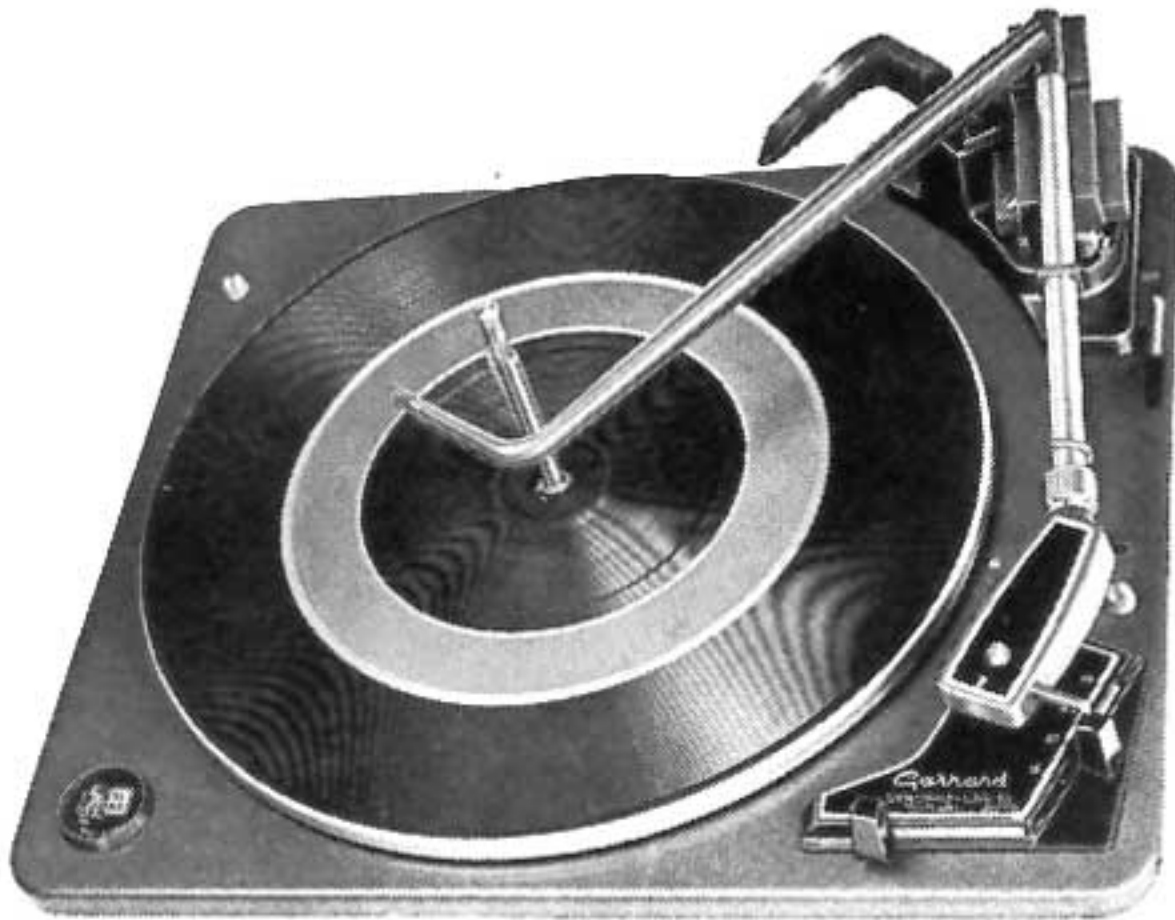

MODEL 50 Mk II
MODEL S.L.55



MODEL 60 Mk II
MODEL S.L.65

ENGINEERS SERVICE MANUAL **AND** **SPARE PARTS LIST**

GARRARD ENGINEERING LIMITED

Service and Spares Department:

NEWCASTLE STREET - SWINDON - WILTSHIRE - ENGLAND

Telephone: Swindon 5381

Contents

General Information
Operating Instructions
Installation and Wiring
Maintenance
Service Adjustments
Record Changer Cycle
Exploded Views
Spare Parts List
Fault Chart

Diagrams

Diagram 1 Line Cord and Socket Connection
Diagram 2 Voltage Changeover Block Connection
Diagram 3 Phono Socket Connection

Diagram 4 Muting Switch Connection
Diagram 5 Tag Strip Connection
Diagram 6 M.7 Plug-in Pickup Shell
Diagram 7 Transit Screw Positions
Diagram 8 Pickup Lifting Mechanism
Diagram 9 Friction Link
Diagram 10 Switch-off Lever and Selector Mechanism
Diagram 11 Intermediate Wheel Height Adjustment
Diagram 12 60 Mk II and S.L.65 Pickup Arm Adjustments
Diagram 13 50 Mk II and S.L.55 Stylus Force Adjustment
Diagram 14 50 Mk II and S.L.55 Pickup Arm Adjustments
Diagram 15 60 Mk II and S.L.65 Cueing Linkage
Diagram 16 60 Mk II and S.L.65 Bias Compensator
Diagram 17 S.L.65
Diagram 18 S.L.65 with Turntable Removed
Diagram 19 Underside View of S.L.65

General Information

This manual serves for Garrard Models 50 Mk II, S.L.55, 60 Mk II and S.L.65. These units have the facility to play records automatically or they can be used manually to play single records.

Models 50 Mk II and S.L.55 are similar, having large diameter steel turntable and diecast aluminium pickup arm with fixed counterbalance weight. Pickup leads terminate at a tag strip or a phono socket/muting switch. The major difference between these two units is that Model 50 Mk II may be fitted with either a two or a four pole induction motor, whereas Model S.L.55 is fitted with the Garrard Synchro Lab motor.

Models 60 Mk II and S.L.65 are also similar to each other. They have a diecast turntable and tubular, counterbalanced pickup arm with bias compensator. Pickup leads terminate at a phono socket or muting switch. Again, the major difference between these two units is that Model 60 Mk II is fitted with the Garrard Laboratory Series four pole induction motor, whereas Model S.L.65 is fitted with the Garrard Synchro Lab motor.

The Garrard Synchro Lab motor uses induction principles to attain running speed: at that speed a magnetic element then locks the rotor so that it runs synchronously with the frequency of the power supply.

Common to all four units is the cueing device and auto mechanism, and service engineers will note that these units have been developed from Models 50 (also known in some areas as 40 Mk II) and A.T.60.

All models will play up to eight mixed records automatically of 7", 10" or 12" diameter. A short manual spindle is supplied for single record play and large centre hole records may be played automatically using adaptor L.R.S. 20 (optional extra). A single play adaptor is also available for use with large centre hole records.

These units also feature plastic foam damped spring suspensions and a plug-in pickup head, designated M7, which will accept a wide range of cartridges.

The units are made in a number of different colour finishes and with differing turntable mat trims. Synchro Lab motors can be supplied to run on 110/130 volts A.C. only or for 110/130 volts and 220/250 volts A.C. The latter version is fitted with a voltage changeover block attached to the motor. (Induction motor voltages 100/130 volts A.C., or 100/130 volts and 200/250 volts A.C.)

The Synchro Lab and 4-pole induction motors are suitable for 50 or 60 Hz according to the motor pulley fitted. The 2-pole motor does not have a removable pulley and a different motor is required for 50 or 60 Hz supply.

These units play automatically when the records are of the same speed and record groove type. They can be stopped and started without rejecting the record being played, or records can be rejected as desired. Switch off is automatic after playing the last record. The cueing device permits the pickup arm to be accurately positioned on a record by manual means and also allows play to be interrupted when used as a pause control.

Before using these record changers make sure that the power supply is as labelled on the motor. If the unit is connected to an amplifier whose wiring is not isolated from the power supply, isolating components should be incorporated in the pickup circuit, otherwise the pickup circuit can become live.

Always disconnect the power supply and protect the pickup, when servicing a unit.

In some cases such as those associated with pickup and power connections, components for these models may vary (other than as illustrated) due to the wide variety of customers' specifications. Therefore, when referring to these models, obtaining spares etc., always quote the code stamped on the inspection label, unless a full description can be given. (See parts list.)

The information in this manual applies to all models covered except where otherwise stated or illustrated.

Garrard units are made to play records complying to B.S. 1928 : 1965 and I.E.C. Publication 98, also similar standards.

Operating Instructions

Automatic Operation

1. See that the correct stylus is in position for the type of record to be played and free the pickup arm on its rest.
2. See that the speed control is set to the correct speed.
3. Place records horizontally on the record spindle step and swing the overarm fully inwards, on to the top record.
4. Switch on by moving the control to 'Auto', pause and release.
After playing all the records, the pickup arm will return to its rest and the unit will switch off.

To Unload

1. Lift the overarm and swing it to the right.
2. Lift the records clear of the spindle, even if replaying.

Manual Operation

1. Place the record on the turntable by threading it over the record spindle. Swing the overarm fully inwards to its operating position.
2. Switch on by moving the control to 'Manual' and place pickup on the record.

After playing the record the pickup arm will return to its rest and the unit will switch off.

The record spindle may be replaced by a short manual spindle for manual operation.

Reject

A record being played may be rejected by moving the control to 'Auto'.

Stop

Move the control to 'Off' and the motor will stop with the pickup remaining on the record. Restart by moving the control to 'Manual' and the same record will continue playing.

Cueing Device

The pickup can be raised from or lowered on to any record on the turntable by operating the cueing lever. This lever can also be used for interrupting either Auto or Manual play for a short time by moving it backwards to lift the pickup from the record.

To resume play, move the lever steadily forwards to lower the pickup on to the record.

Note:

To avoid damage to the stylus, do not move the control to 'Auto' until records are loaded on the record spindle.

Do not leave records on the unit when not in use.

Keep the stylus point free from dust.

To obtain best results from records, store and clean them as recommended by the record manufacturers.

Installation and Wiring

Cabinet Space

Models 50 Mk II and S.L.55 are $13\frac{1}{8}$ " (354 mm) wide by $11\frac{3}{8}$ " (289 mm) front to rear by $4\frac{3}{8}$ " (106 mm) above and $2\frac{3}{4}$ " (70 mm) below lower edge of unit plate. The latter figure is 2" (51 mm) if 2-pole motor fitted.

Models 60 Mk II and S.L.65 are $15\frac{1}{8}$ " (383 mm) wide by $12\frac{1}{2}$ " (317 mm) front to rear by $4\frac{5}{8}$ " (110 mm) above and $2\frac{3}{4}$ " (70 mm) below lower edge of unit plate.

The actual unit dimensions are given and where applicable include the rear and side overhang of the pickup arm.

Clearances required are obtained by adding $\frac{1}{2}$ " (12 mm) to all dimensions. This will give $\frac{1}{4}$ " (6 mm) clearance all round edge of unit and $\frac{1}{2}$ " (12 mm) above and $\frac{1}{2}$ " (12 mm) below allowing unit to float freely on its mounting springs and be clamped for transit.

According to the design of the cabinet or case, additional clearance may be required around the control area and for record handling, also as clearance for 12" records and removal of record spindle.

Unpacking

When unpacking a unit received from the factory, withdraw it from its carton as instructed on the carton inner flap; never lift the unit by its pickup arm or overarm. Carefully remove all packing ties, rubber bands, polythene sleeves and

cardboard fittings — including the wedge between the motor and unit plate. Accessories are found in the cavities of the polyfoam pack.

Support the unit on its mountings and fit the counterbalance weight to the rear extension of the pickup arm. On Models 50 Mk II and S.L.55 align locating pin on weight with slot in tube and push weight until it locks in position, where it will be permanently held. On Models 60 Mk II and S.L.65 make sure the counterbalance weight has its clamping screw forward as in diagram 17; instructions for setting stylus pressure and connecting bias compensator are found under 'Service Adjustments'.

Record spindles for these models are located in the turntable spindle by the retaining clip; therefore take care to position record spindles correctly when fitting.

Preparing Mounting Board

If it is necessary to prepare a mounting board, do so by drilling and cutting out the board to the paper template supplied with each unit. Do not moisten the template, but fix it to the board with adhesive tape. Recommended board thickness is between $\frac{1}{8}$ " and $\frac{1}{2}$ ". Should a thicker board be used, it may be necessary to recess the $\frac{3}{8}$ " diameter holes from the underside to $1\frac{1}{8}$ " diameter, to clear the transit screw clips.

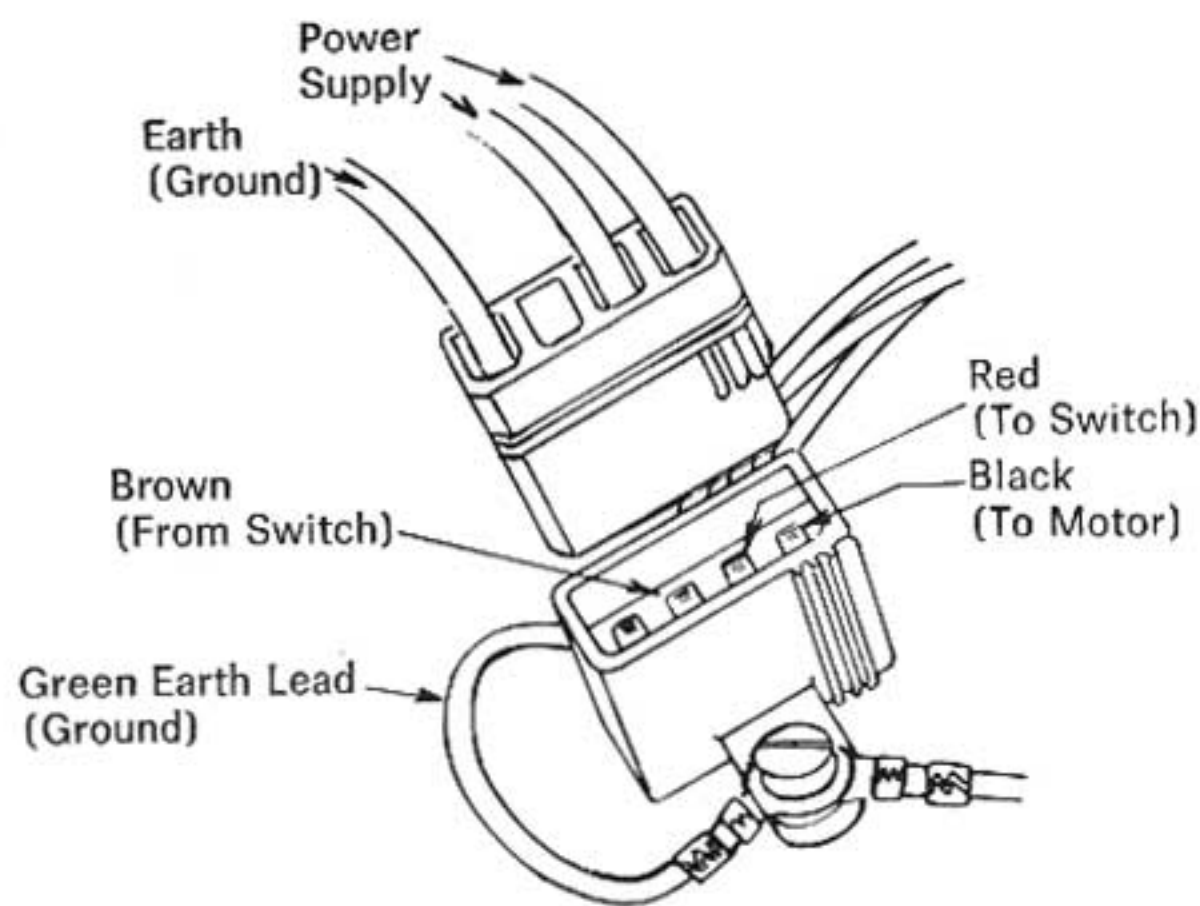

Diagram 1

Motor Wiring

Before assembling the unit into the cabinet, connect a power supply lead to the terminal block, or voltage changeover block if a high and low voltage motor is fitted. Connect an earth lead to the earthing tag on the motor. A connecting plug and socket may already be fitted on certain units. See diagrams 1 and 2.

Switch Click Suppressor

Some units may have a switch click suppressor incorporated in the motor switch, consisting of a capacitor, 10,000PF +80% -20%, wired across the switch blades. On most units this forms part of the plug-in loom assembly.

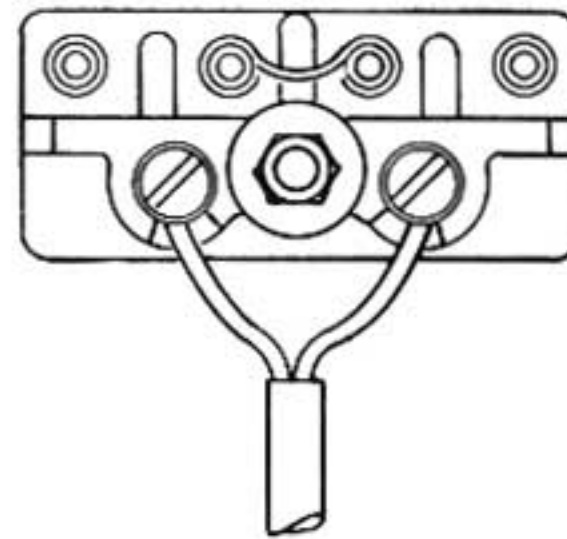

Links Set for 220/250 Volts

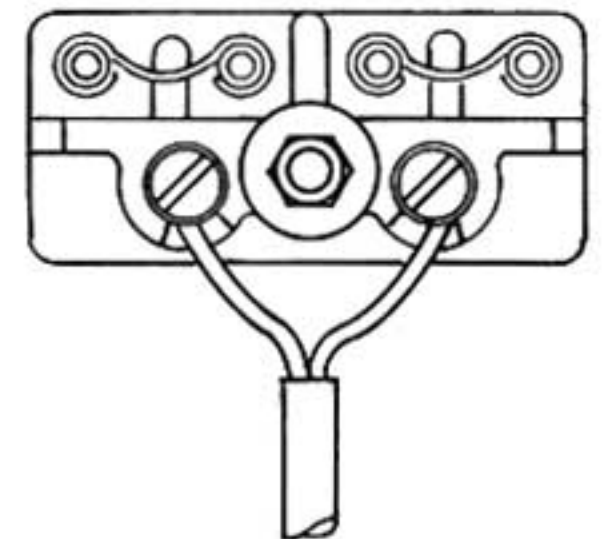

Links Set for 110/125 Volts

Diagram 2

Pickup Wiring

Screened leads should be connected to the pickup tag strip, or on some units the tags on the muting switch, suitable for connection to the amplifier as shown in diagrams 4 and 5. Certain units have phono sockets fitted to them to which phono leads may be connected, see diagram 3.

Before connecting the record changer to the amplifier, make sure that the pickup circuit of the radio set or amplifier to which it is to be connected, is isolated from the power supply. If it is not, then it is essential for isolating components to be incorporated in the pickup circuit. The pickup lead should be kept as short as possible and its screening connected to a good earth.

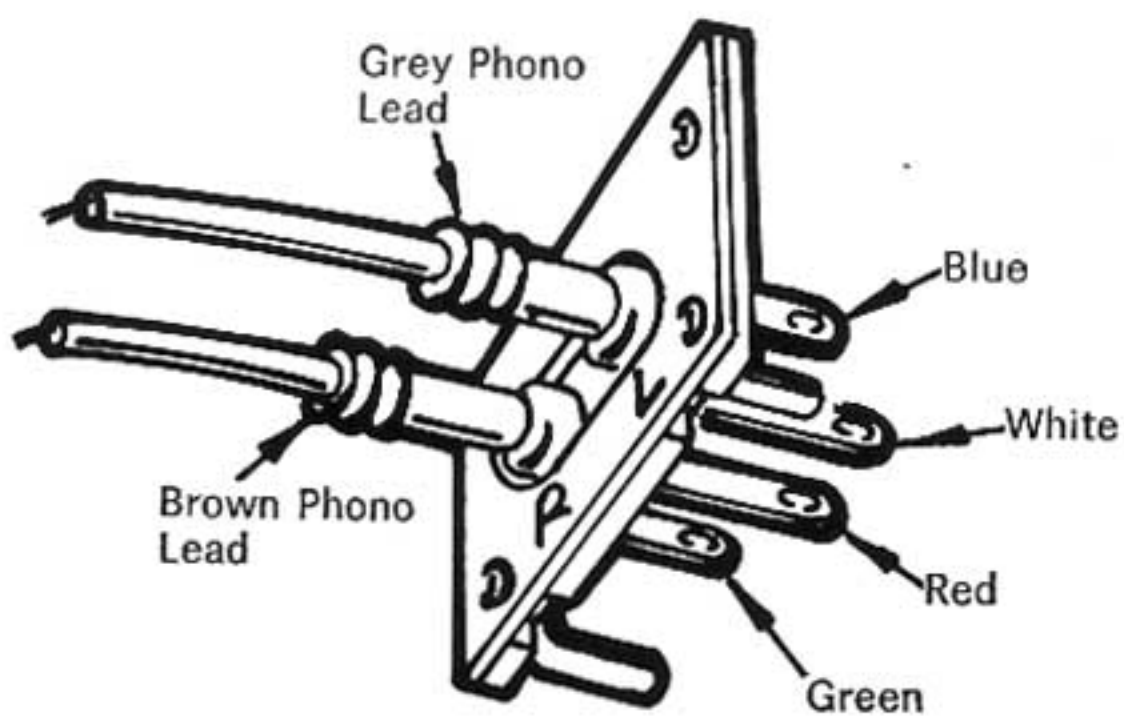

Diagram 3

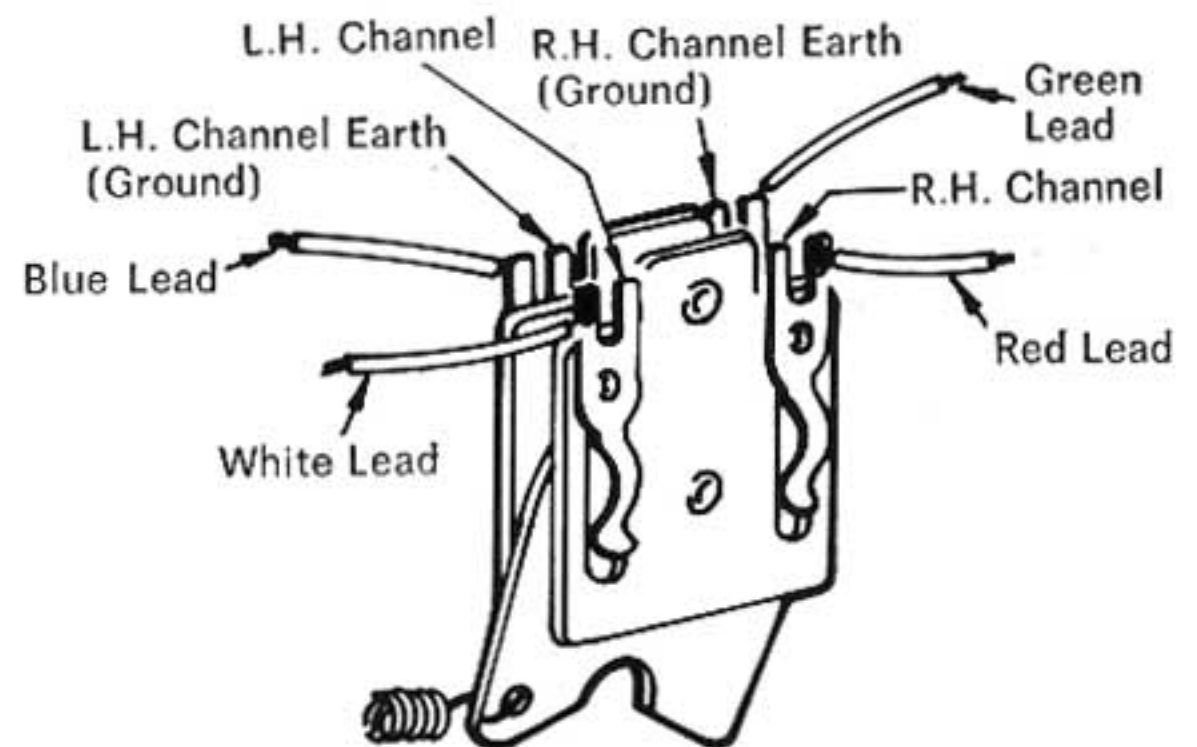

Diagram 4

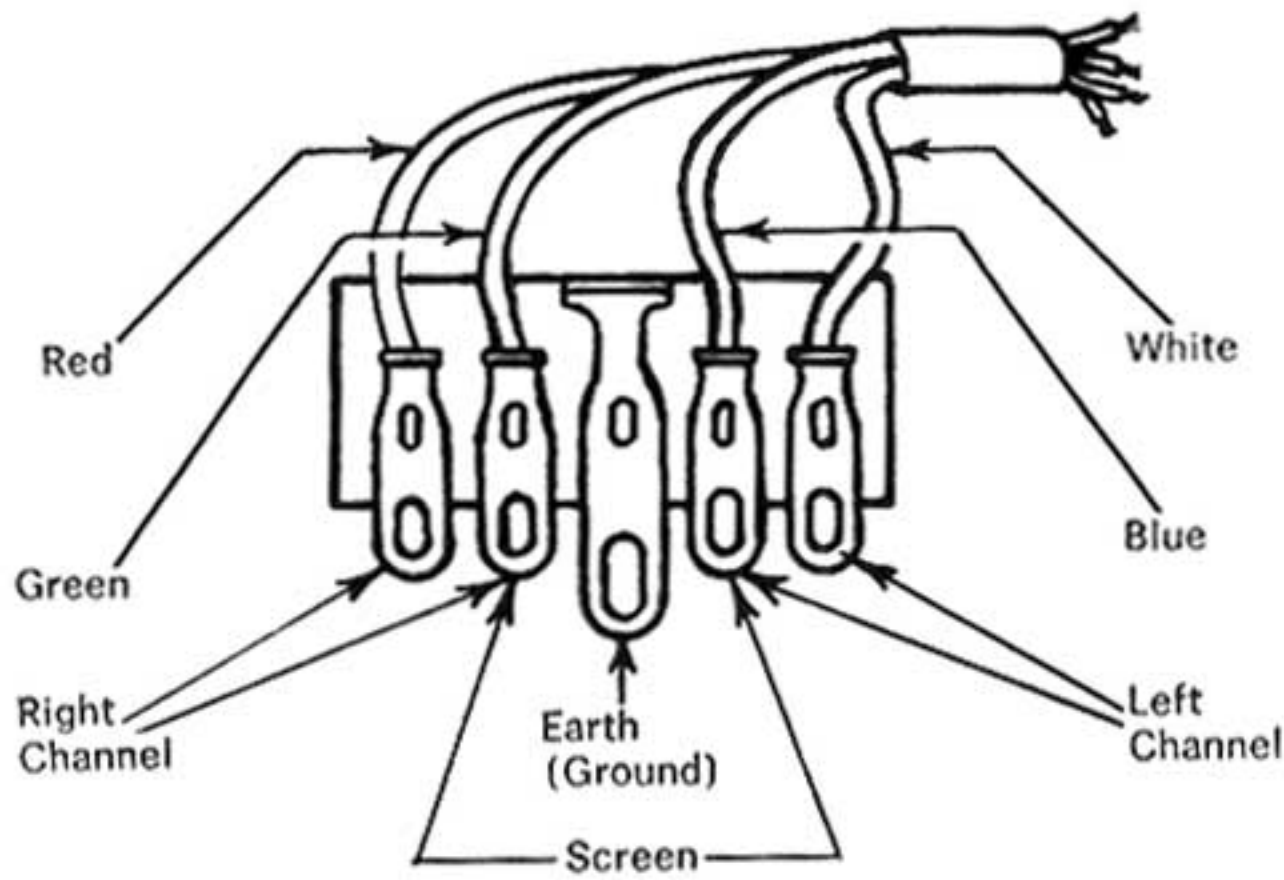

Diagram 5

Fitting Cartridge

A plug-in pickup shell designated M7 is used on these units. This may be supplied with or without a pickup cartridge. The pickup shell kit, less cartridge, part number 59048, contains a set of fixing accessories comprising:

- Alternative mounting plates
- Two 6 BA x $\frac{1}{16}$ " screws
- One 6 BA x $\frac{1}{8}$ " screw

These parts allow most types of cartridge to be fitted without difficulty by screwing the cartridge to the mounting plate which has the most suitable length of stand off and securing the assembly to the pickup shell with the $\frac{1}{8}$ " screw. Cartridges having a single fixing hole may be fitted directly to the pickup shell using the $\frac{1}{8}$ " screw.

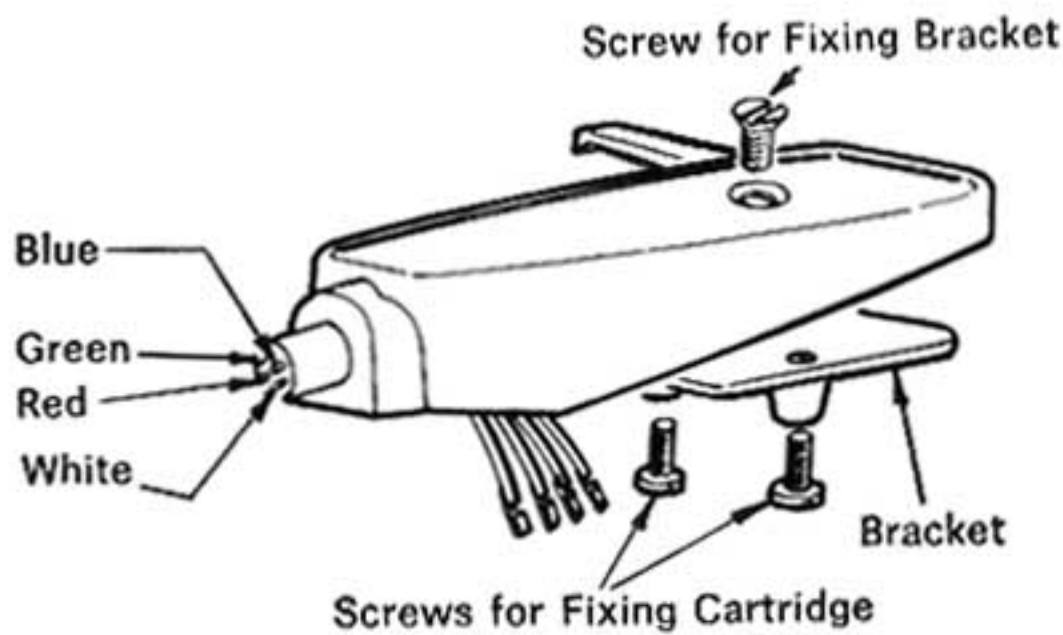

Diagram 6

Connect the colour coded leads in the pickup shell to the connection tags on the cartridge. Do not solder leads to the cartridge. If the cartridge terminations are sockets a special connector must be used. Lead connections should be made as follows:—

- Red to Right Channel Signal
- Green to Right Channel Ground
- White to Left Channel Signal
- Blue to Left Channel Ground

Information on its connections are usually supplied with the cartridge. For cartridges having three connections, use the green lead as the common connection or join the green and blue leads together and use these as the common connection. For monophonic cartridges use the red and green leads. Insulate and tuck away any leads not required.

Fitting in Cabinet

The unit should be placed on the board so that the spring mountings locate correctly and the transit screws go through their respective holes. When in position, the spring locks on the ends of the transit screws should be turned through 90° so that they lie parallel to the motor board as in diagram 7.

In use, check that the two screws are screwed down clockwise and that the unit is floating freely on its mounting springs. Before transit, turn the transit screws counter-clockwise so that the unit is held against the motor board as in diagram 7.

Note that all these units will fit the appropriate Garrard Mounting Base (or its equivalent in U.S.A.).

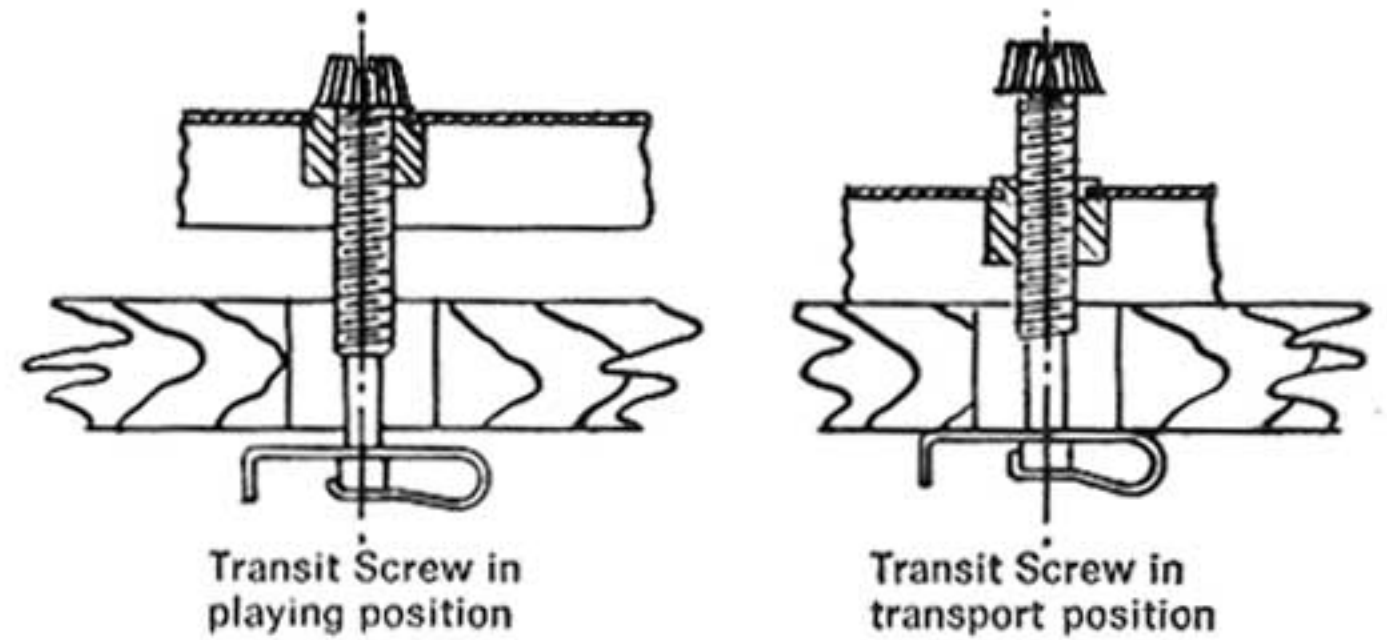

Diagram 7

Maintenance

Disconnect the power supply and protect pickup before carrying out maintenance.

To remove turntable

Pull out the record spindle (31) from its location, then if 60 Mk II or S.L.65 mat is fitted, prise out the nameplate from the centre of the turntable — taking care not to damage the turntable mat. Remove the turntable retaining clip (32) using a small screwdriver and noting the clip's location for correct reassembly (small hole to rear-left), then lift the turntable with equal pressure on diametrically opposite sides.

When replacing the turntable, check that the tooth gap on the cam gear (41) is adjacent to the turntable spindle and that the automatic trip pawl (43) is pushed clear of the turntable spindle. Replace the turntable retaining clip (32) taking care that the clip and record spindle (31) locate correctly. When fitting 60 Mk II or S.L.65 turntable nameplate, take care not to damage the mat. Using a screwdriver, gently stretch the mat to sandwich in position the 3 locating segments of the nameplate.

The overarm

When swung fully inwards, the overarm must drop freely in its location. If stiff, remove circlip on overarm spindle (beneath unit), withdraw overarm and clean and oil its spindle.

Lubrication

The bearings of the motor, turntable spindle and rubber intermediate wheel (50) are of the oil retaining type and rarely need lubricating. When the need for oil is apparent, remove the turntable and lubricate these bearings with a fine grade of machine oil. Carefully remove excess oil, particularly from the motor pulley, rubber intermediate wheel (50) and inside turntable rim by wiping these driving surfaces with a clean cloth.

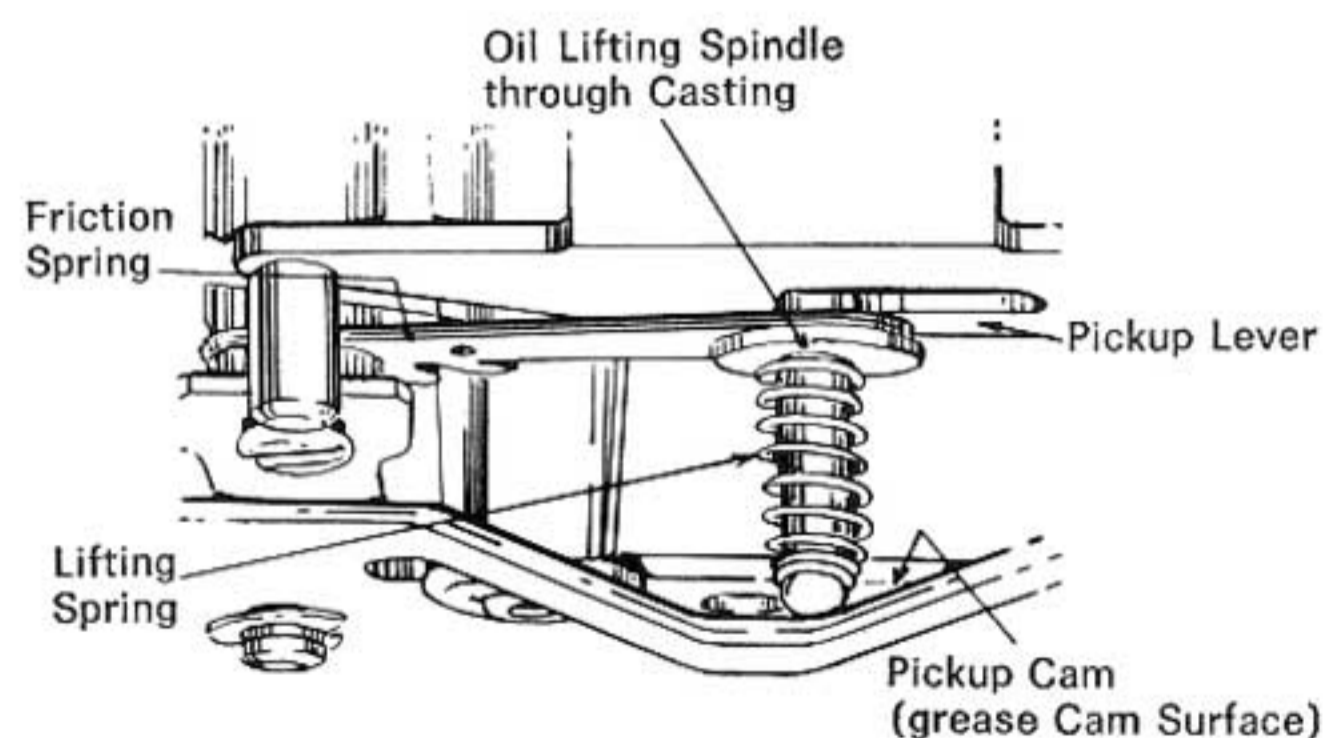

Diagram 8

Other pivots or working faces may need oil or grease from time to time. They are:—

1. Pivots for vertical movement of 50 Mk II and S.L.55 pickup arm — a spot of thin oil.
2. Pivots for horizontal pickup arm movement — a spot of thin oil.
3. Oil overarm lever (77) where it contacts overarm spindle (3).
4. Oil overarm spindle (3) through hole in lower casting (78) so that the overarm drops freely when in its inward position.
5. Oil spindle of cam (41).

A smear of grease may be applied occasionally at the following points:—

1. Friction link (92), working face as on diagram 9.
2. Control lever (66), working face against pin in switch lever (72).
3. Unit plate where switch lever pin (72) rubs.
4. Pickup cam (93), working area and end of lifting spindle (91) as in diagram 8.
5. (a) Pillar in pickup cam (93), running in unit plate slot.
(b) Washer on lower casting (78), where it rubs pickup cam (93), see diagram 10.
(c) Face of pickup cam (93) operating switch off lever (76), see diagram 10.
6. Release lever (96), operating face against pin in pickup cam (93).
7. Track of cam (41).
8. Speed cam (112), top and side faces.
9. Support lever pin (110), operating face.
10. Switch off lever (76), slot, ends lever and underside of unit plate.

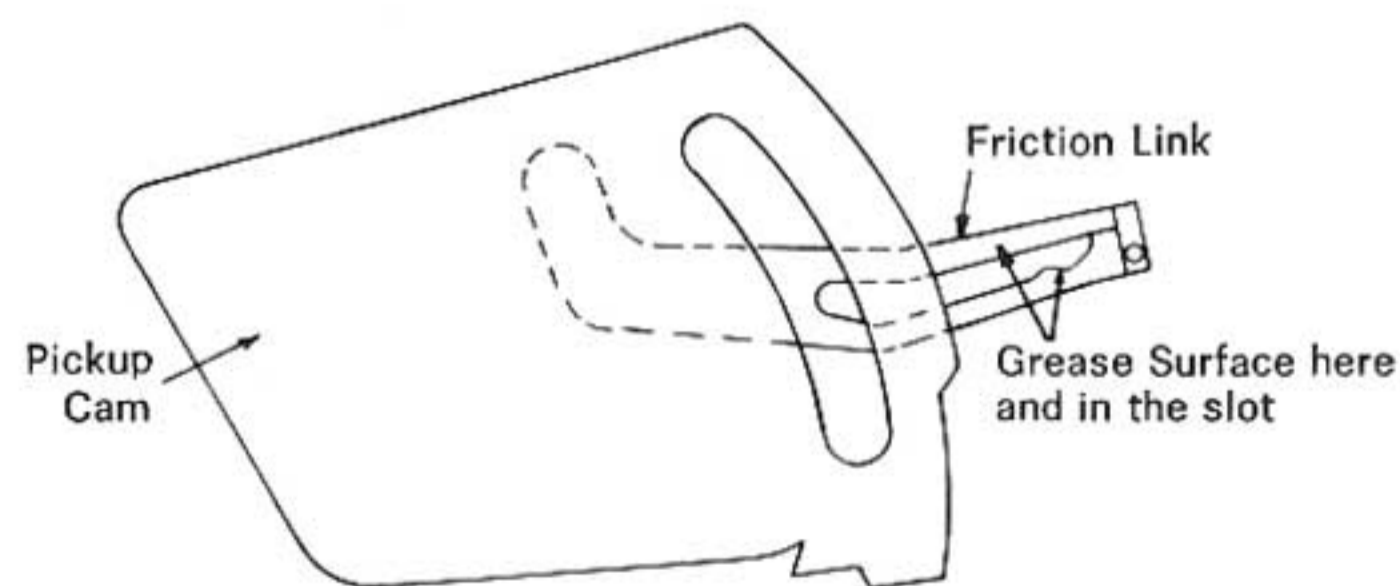

Diagram 9

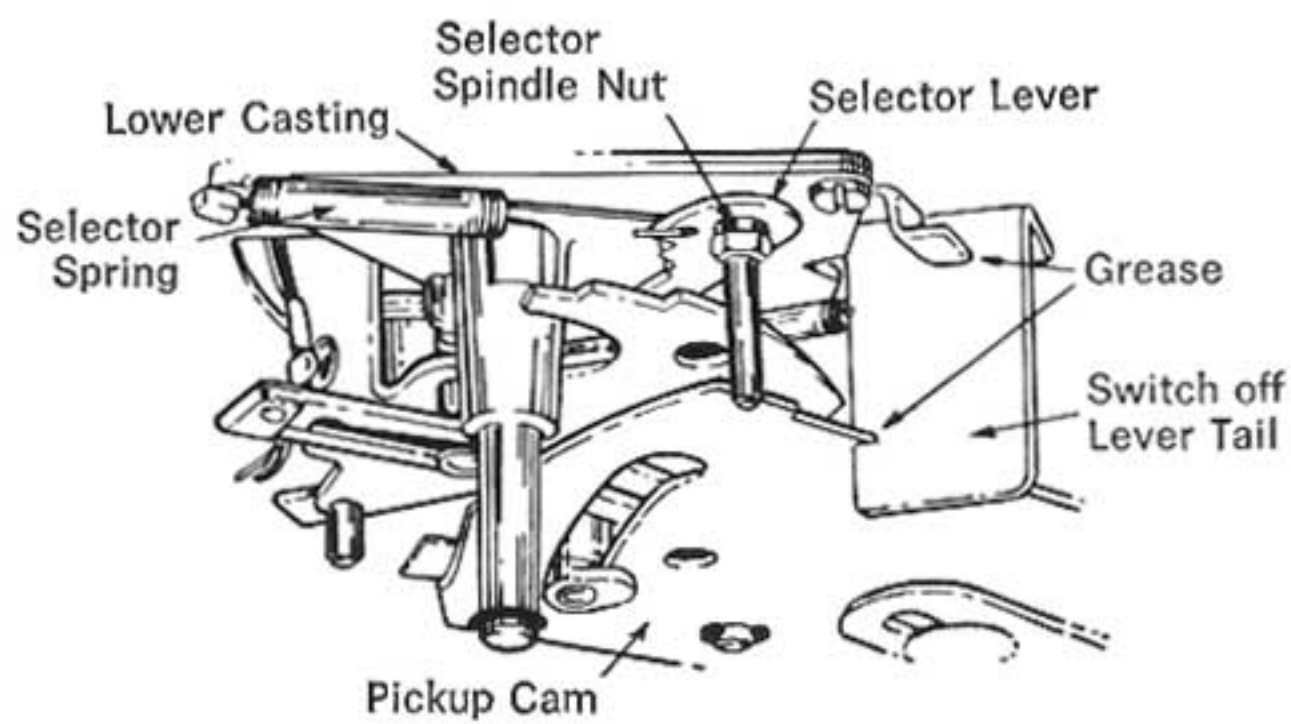

Diagram 10

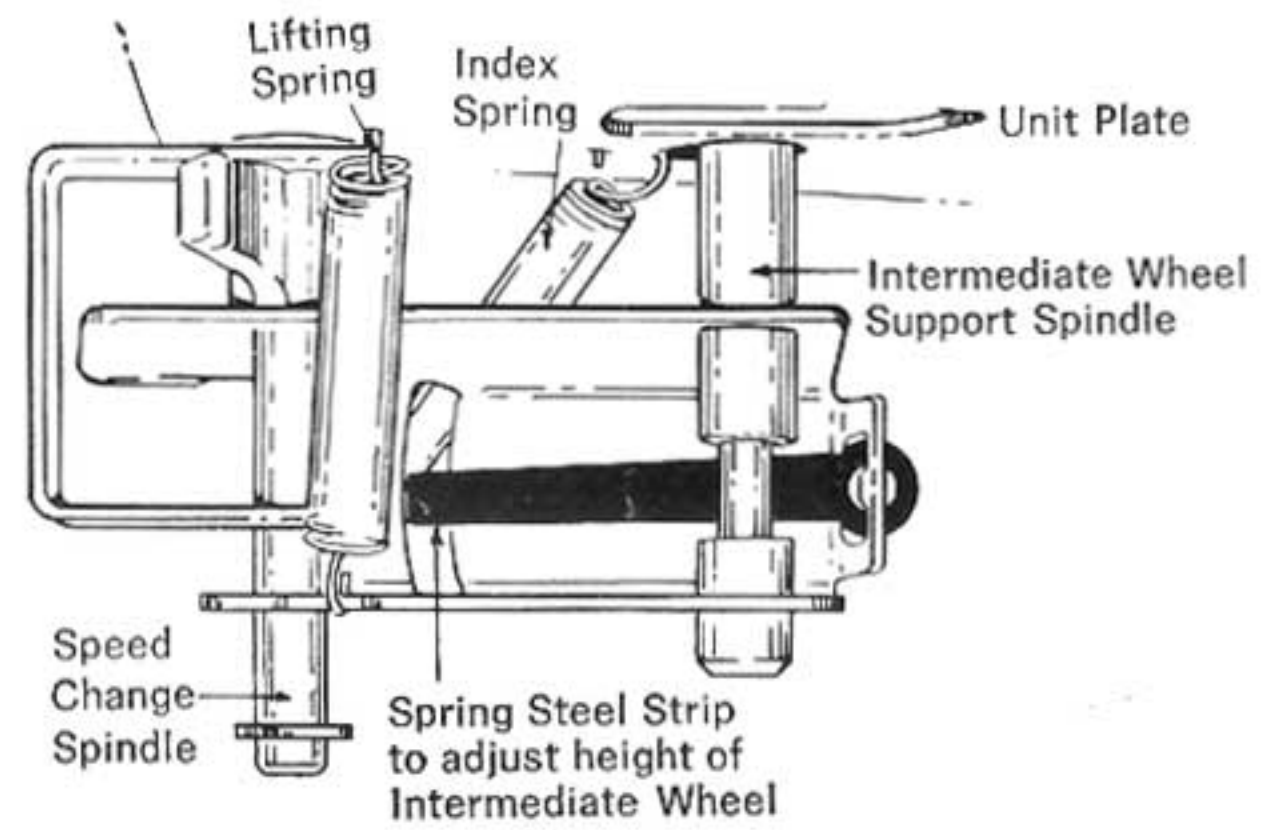

Diagram 11

Service Adjustments

Speed

If the speed varies other than because of warped records slipping, remove the turntable and clean the driving surfaces as stated under 'Maintenance'. Should the turntable run fast or slow consistently, check that the motor and motor pulley match the power supply. The motor is labelled with its power supply details and the motor pulley, if the removable type, is colour finished for identification, nickel for 50 cycle and brass for 60 cycle power supply. If a 4-pole motor pulley (115G) check that the grub screws are tight. The 2-pole motor pulley is integral with the shaft and is not removable.

Check that the rubber intermediate wheel (50) runs in the centre of the appropriate pulley step and is not rubbing the side of the adjacent step. If necessary adjust the intermediate wheel height setting blade. This blue spring steel blade (110A) adjusts the position of the spindle on which the rubber intermediate wheel (50) is mounted. See diagram 11.

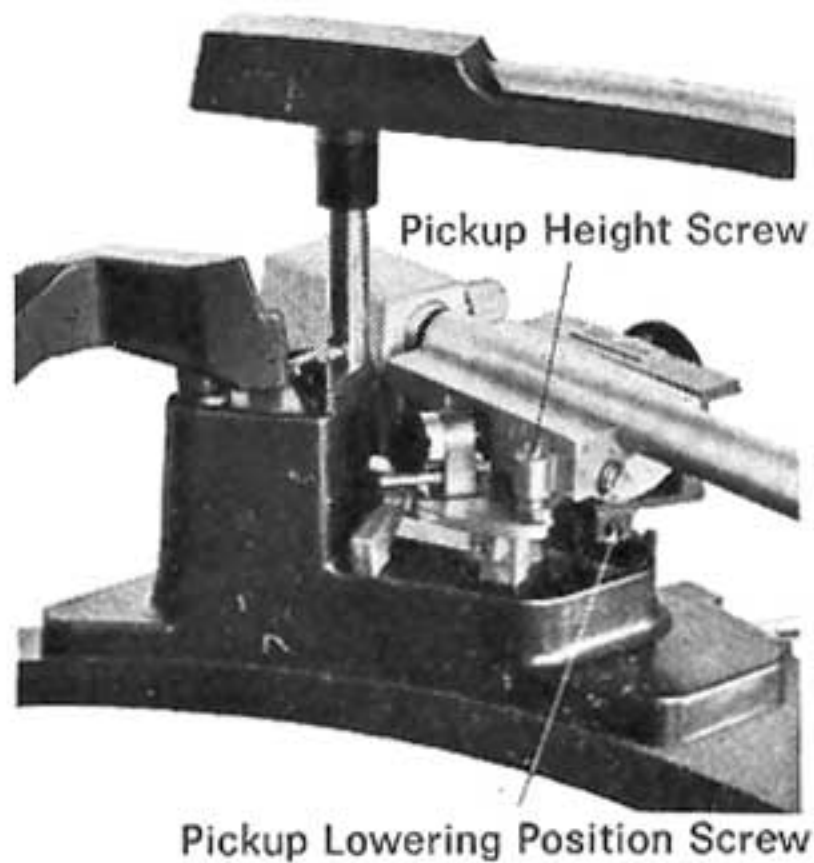

Diagram 12

To Remove Motor Pulley

The pulley has minimum clearance between its bore and the motor shaft, to ensure true running. If, with its locking screws loosened, the pulley is tight on the shaft, apply gentle heat to the base of the pulley for about 30 seconds using a small, clean soldering iron; the pulley should then slide off easily. Use this method to fit a new pulley if necessary, but

take care not to damage the intermediate wheel or motor wiring when using a soldering iron.

Pickup Dropping Position

This position is preset but may be adjusted by turning screw (24) clockwise to move the dropping position in and counterclockwise to move the dropping position out on Models 50 Mk II and S.L.55. For 60 Mk II and S.L.65 models, grub screw (24A) adjusts the dropping position in a similar manner. See diagrams 12 and 14.

Pickup Height

Pickup arm lift on automatic cycle can be adjusted on Models 50 Mk II and S.L.55 by turning screw (6) set vertically in the rear of the pickup arm, clockwise to decrease and counterclockwise to increase pickup height. 60 Mk II and S.L.65 models are adjusted by screw (6A) turned clockwise to increase and counterclockwise to decrease pickup height. For all models the stylus tip should be set $\frac{3}{4}$ " above one record on the turntable mat, as the arm returns to its rest. See diagrams 12 and 14. The settings given may need to be reduced if cartridges of a greater overall height than the normal range are fitted. Reducing the setting decreases the number of records that can be played in automatic sequence. Pickup dropping position and height are best adjusted with the unit switched off. Load a single record on the record spindle step, switch on to 'Auto' and operate the changer cycle by revolving the turntable clockwise by hand.

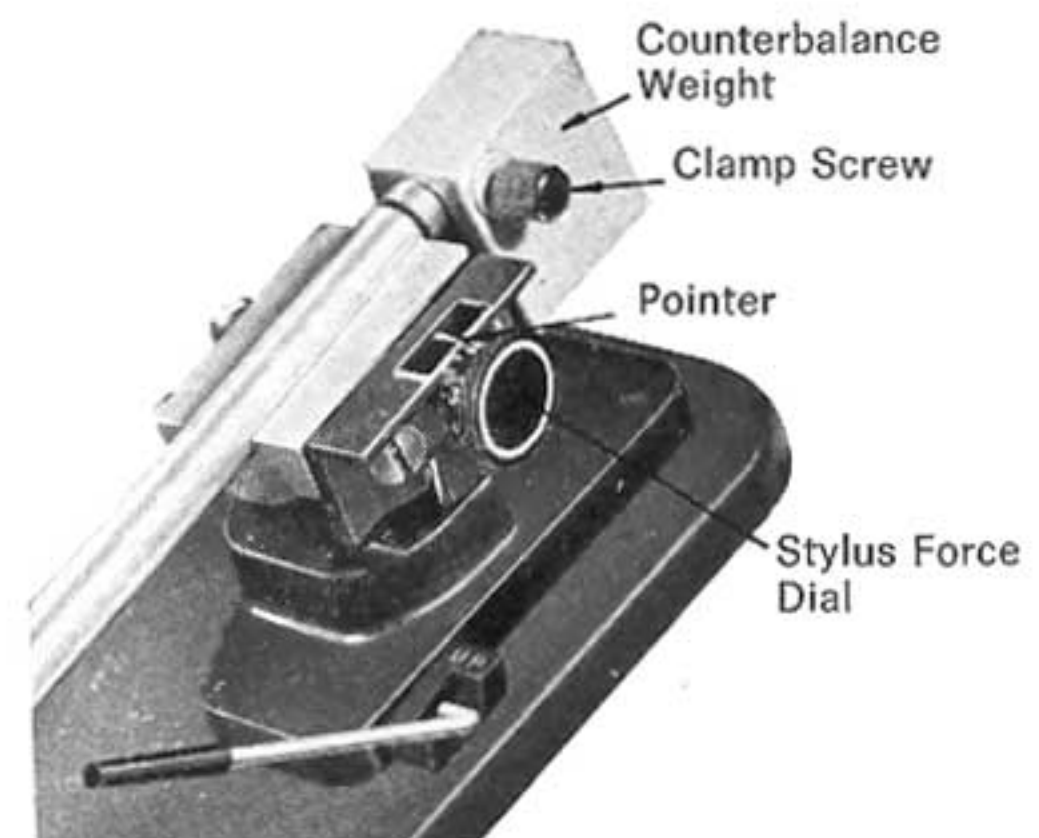

Diagram 13

Pickup Tracking

Should there be a tendency for the pickup to track incorrectly, check that the correct stylus is in use and clean any dust build-up from the stylus. Make sure the stylus force is correct for the cartridge fitted and see that the leads from the pickup are free and not rubbing any mechanism. Also see that the unit is reasonably level. The unit mounting board may need packing. If a Model 60 Mk II or S.L.65 pickup tracking should not be affected by the level of the unit because the pickup arm is fully counterbalanced. Check, however, that the 60 Mk II and S.L.65 bias compensator is connected and pivots freely, unless tracking at very low stylus pressures, in which case it may be found preferable to disconnect the compensator. If a later model with cueing adjustment, see also 'Cueing' paragraph.

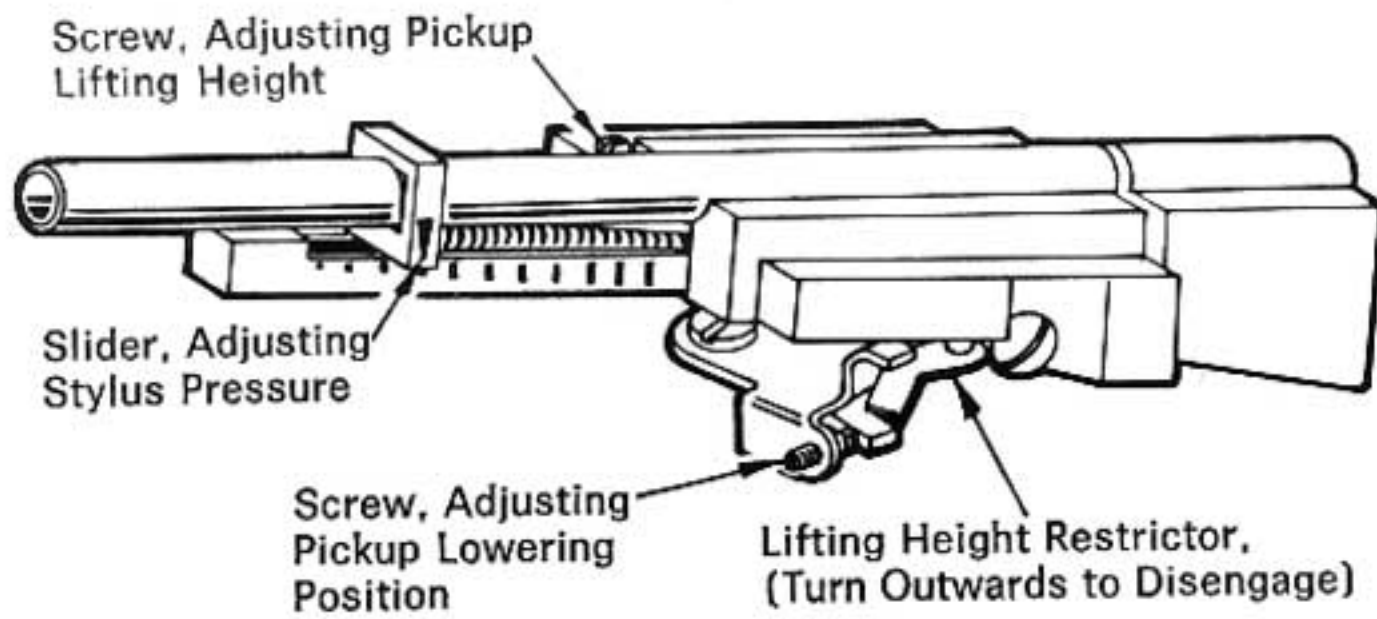

Diagram 14

Cueing

On early models the cueing mechanism operates through the pickup height adjustment linkage. See diagram 15. On later models an adjustment screw, accessible through a hole in the top of upper casting (40) allows the cueing mechanism to be adjusted, should it apply unwanted friction to friction spring (87) while the pickup arm is tracking.

Stylus Force

This should be set to the force recommended. If a Model 50 Mk II or S.L.55, check occasionally with a stylus force gauge, adjusting the stylus force by moving the slider (14A) on the top of the pickup arm frontwards to decrease and backwards to increase stylus force.

60 Mk II and S.L.65 models have a built-in stylus force gauge. To set, turn dial (14) to zero, then loosen the screw (123) holding the counterbalance weight (122) on the rear of the pickup arm. With the pickup arm off its rest, slide the weight along the arm until the weight balances the pickup arm (the arm will lie horizontal), then tighten the counterbalance weight screw (123). To set the required stylus force, turn the dial (14) — marked in one gram divisions — to the required figure. See diagrams 13 and 14.

Pickup Muting Switch

On some models a muting switch (101A) is fitted, which short circuits the pickup connections during the time that the changing mechanism is in action. If this fails to operate, check that the contacts are making and breaking correctly and that the wiring is secure. See that the bracket on which the muting switch is mounted is correctly positioned against the two small half-pierced lugs in the unit plate. If it is not, loosen the bracket fixing screw and position the switch correctly.

Removing and Replacing Plug-in Pickup Head

Unscrew locking collar (4A) clockwise and gently pull the head from the arm. To replace the pickup head, locate the pin on the pickup head in the slot of the pickup arm and slide the head in. Bring the locking collar forward, locating its slot over the pickup head pin and screw the collar up until tight.

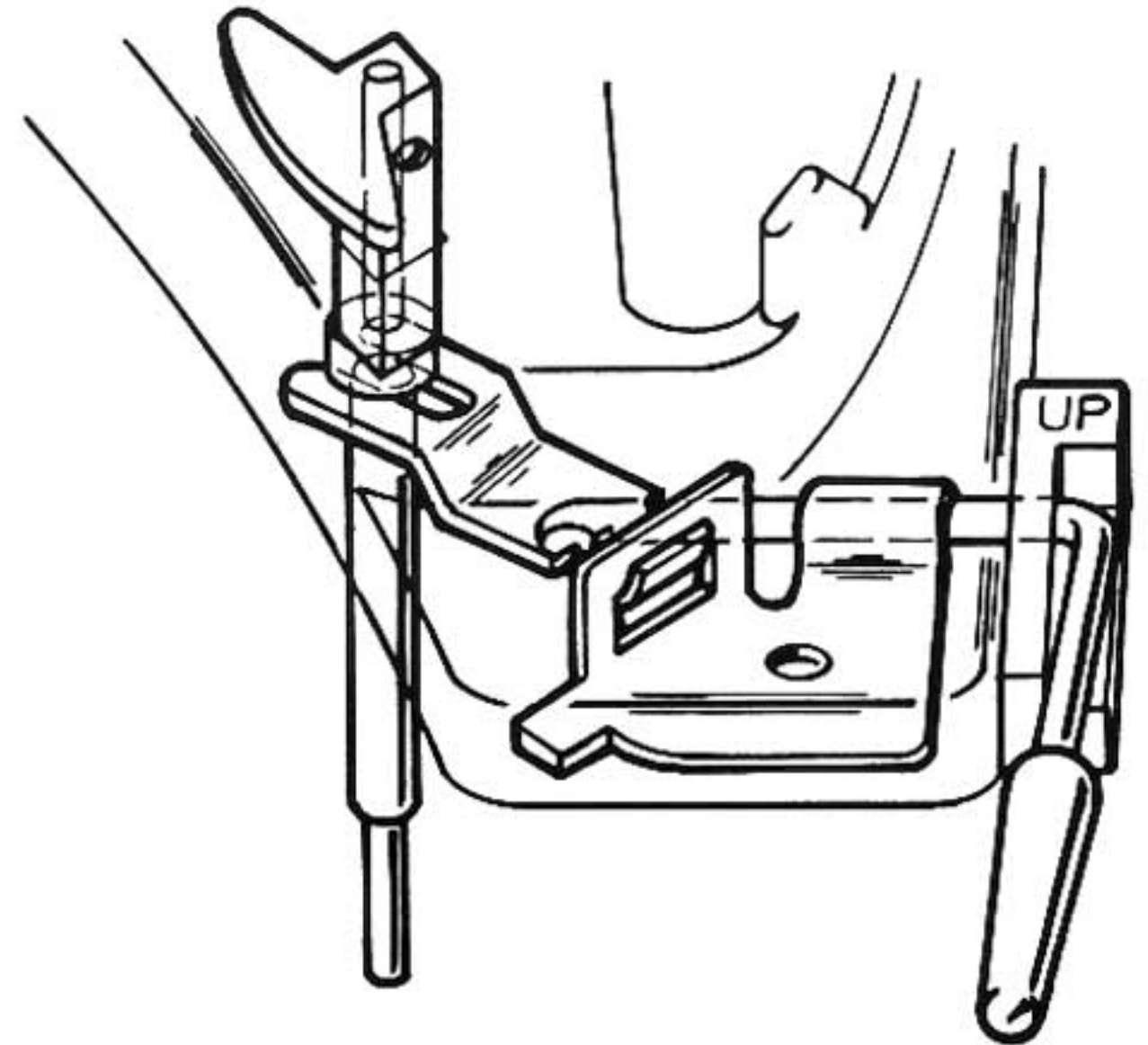

Diagram 15

60 Mk II and S.L.65 Bias Compensator

Models 60 Mk II and S.L.65 may be supplied with bias compensator disconnected. If this is the case then the pin bracket (129) should be swung from the position shown in diagram 16a to the position shown in diagram 16b so that its pin will carry the compensator weight as the pickup arm tracks.

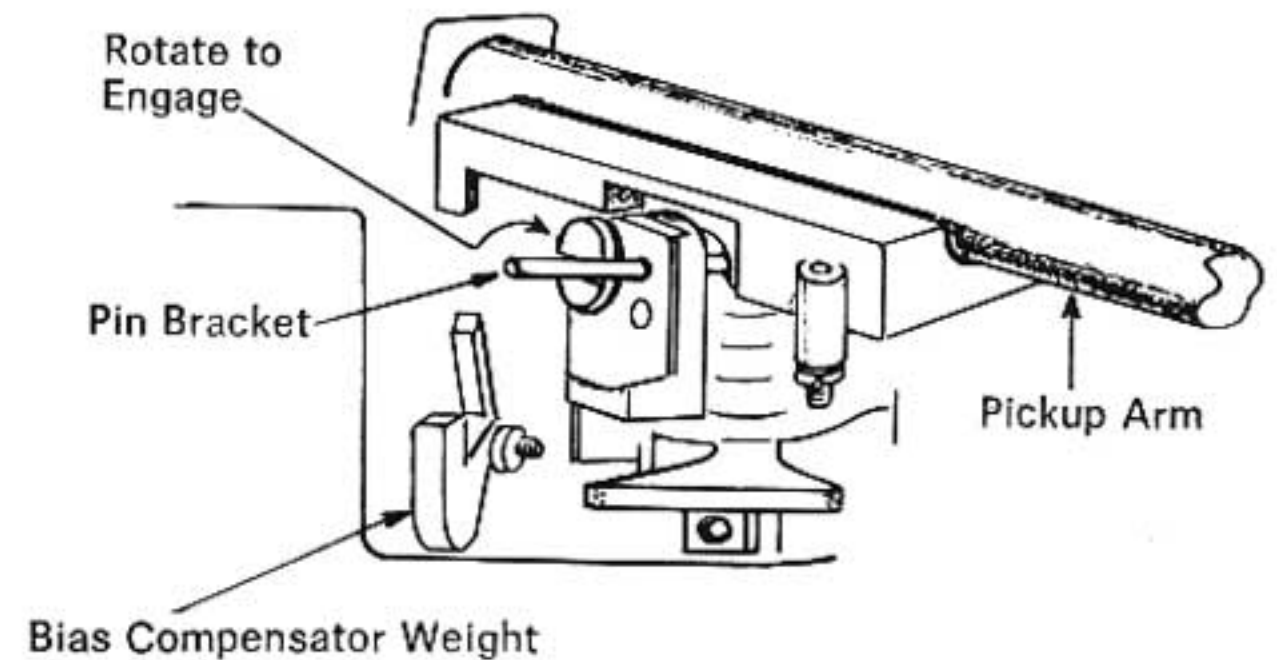

Diagram 16a

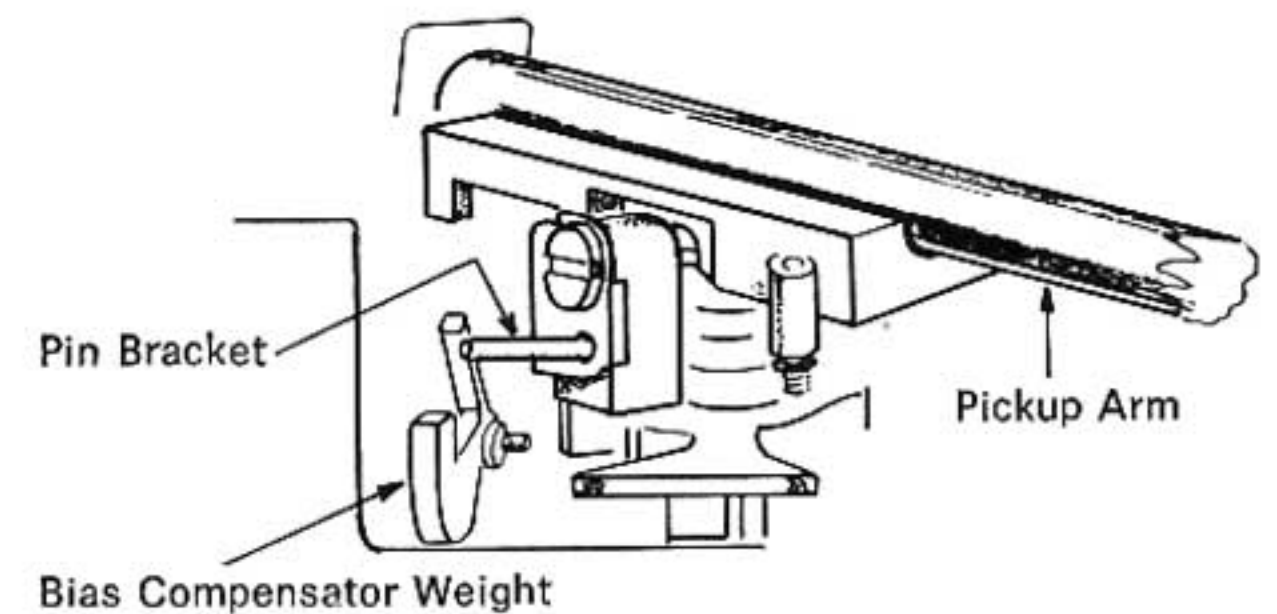

Diagram 16b

Record Changer Cycle

Turntable Drive

The record changer cycle is commenced by moving control lever (66) to 'Auto' position, pausing and allowing it to spring back to the 'Manual' position.

The end of control lever (66) acts as a cam and pivots switch lever (72), the forked end of which holds tension link (46). The tension link (46) is pushed as switch lever (72) pivots, and slides forward, itself pivoting tension lever (47) to which one end of rubber intermediate wheel spring (54) is connected. The other end is connected to support lever unit (63) which carries rubber intermediate wheel unit (50). Thus as tension lever (47) pulls spring (54), rubber intermediate wheel (50) is drawn into engagement with motor pulley and inside of turntable rim.

A moment after rubber intermediate wheel (50) has taken up its driving position, a lug on switch lever (72) depresses the plunger (103D) which supplies power to the motor, thus revolving the turntable via its drive.

Trip Mechanism

The same control lever (66) movement which initiates the turntable drive also operates the trip mechanism.

Reject lever (71), attached to the manually operated control lever (66), slides automatic trip lever (89) towards the turntable centre. A pin in automatic trip lever (89) operates through the unit plate (55A) to push pivot plate unit (45), which in turn pushes trip pawl (43), pivoted from cam (41), towards the turntable centre. The lug on trip pawl (43) enters the path of the cast lug on the revolving turntable boss. The lugs collide and the trip pawl (43) is swept along so that the cam (41) to which it is attached, is moved sufficiently for its teeth to mesh with the teeth on the turntable boss, commencing a changer cycle.

It will be noted from the above that a pause after moving control lever (66) to 'Auto' is advisable to give opportunity for the trip pawl (43) to engage the turntable boss lug.

Pickup Arm Movement and Record Dropping

As cam (41) is driven round, its cam track guides the roller of pickup cam (93), causing pickup cam (93) to pivot towards the front of the changer. This movement lifts lifting spindle (91) up the inclined perimeter of pickup cam (93). Lifting spindle (91) raises the pickup arm.

At the same time, pickup cam (93) is pushing release lever (96) towards the turntable centre. Release lever (96) pivots the vertically mounted pawl in record spindle (31) which pushes the bottom record off the record spindle step.

The pickup arm dropping position is determined by the dropping record.

When a 7" diameter record drops, it does not touch selector (1), consequently selector lever (82), which selector (1) carries on its spindle, stays set to engage selector lever stop pin with its 7" notch. This positions the selector spindle to act as a stop for the 7" step of pickup lever (85).

When a 10" or 12" diameter record drops to the turntable, its edge strikes the selector (1) in falling. The selector arm movement pivots the selector lever (82) far enough for it to move in and engage the selector lever stop pin with its appropriate 10" or 12" notch. This positions the selector spindle to act as a stop for the 10" or 12" step of pickup lever (85).

At this stage in the cycle of cam (41) by means of its cam track, it reverses the movement of pickup cam (93) which now pushes friction link (92). The friction link (92) pivots the pickup arm inwards via pickup lever (85) until the appropriate step in the pickup lever (85) is stopped by the selector spindle (1).

The pickup cam (93) continues its reverse movement and lifting spindle (91) now drops back down the inclined perimeter of the pickup cam thus lowering the pickup arm on to the record. The continued movement of pickup cam (93) now brings it into contact with selector spindle (1) which it sweeps clear of pickup lever (85), thereby allowing the pickup arm to track the record freely. Cam (41) completes its cycle and comes out of mesh with its tooth gap adjacent to the turntable boss.

Starting New Cycle Automatically

As the pickup arm enters the lead-out record groove, pickup lever (85) comes up against and starts pushing automatic trip lever on cam (41) which moves the trip mechanism towards the turntable boss as previously described. A premature change cycle is prevented by the turntable boss lug tapping away trip pawl (43) until the accelerated motion imparted by the lead-out groove causes the lug to trip the trip pawl (43) and commence a new cycle.

Since the pickup arm is now in the centre, however, when pickup cam (93) is first pivoted forward, the attached friction link (92) carries the pickup arm back to the pickup rest just after the lifting spindle (91) lifts the arm off the record. This positions the pickup arm to allow the next record to drop, or ready to switch off.

Automatic Switch Off

In a normal cycle, pickup cam (93) swings back and sweeps the switch off lever on lower casting (78) with it. The switch off lever returns under spring pressure to its playing position guided by overarm lever also on lower casting (78).

After the last record has dropped, however, overarm (3) drops to its bottom position and a notch in its spindle falls adjacent to overarm lever on lower casting (78), allowing this lever some movement.

Therefore when switch off lever on lower casting (78) returns with pickup cam (93), it moves overarm lever on lower casting (78) into the overarm spindle notch and is pulled by its spring into a stop position for the 7" step of pickup lever (85), preventing the pickup arm from being carried into the 7" dropping position. Pickup cam (93) continues its movement and pushes switch off lever on lower casting (78) along its new course.

Consequently, a cut-out in the end of switch off lever on lower casting (78) pushes the pin in switch lever (72) holding switch lever (72) and control lever (66) in position. This action releases control lever (66) which is pulled to the 'Off' position by return spring (70). Control lever (66) resets switch off lever on lower casting (78) which allows switch lever (72) to retract the intermediate wheel mechanism and also allows switch plunger (103D) to spring out, cutting out the power supply.

(continued on page 19)

Exploded View Above Unit Plate

Models 50 Mk II, S.L.55, 60 Mk II, S.L.65

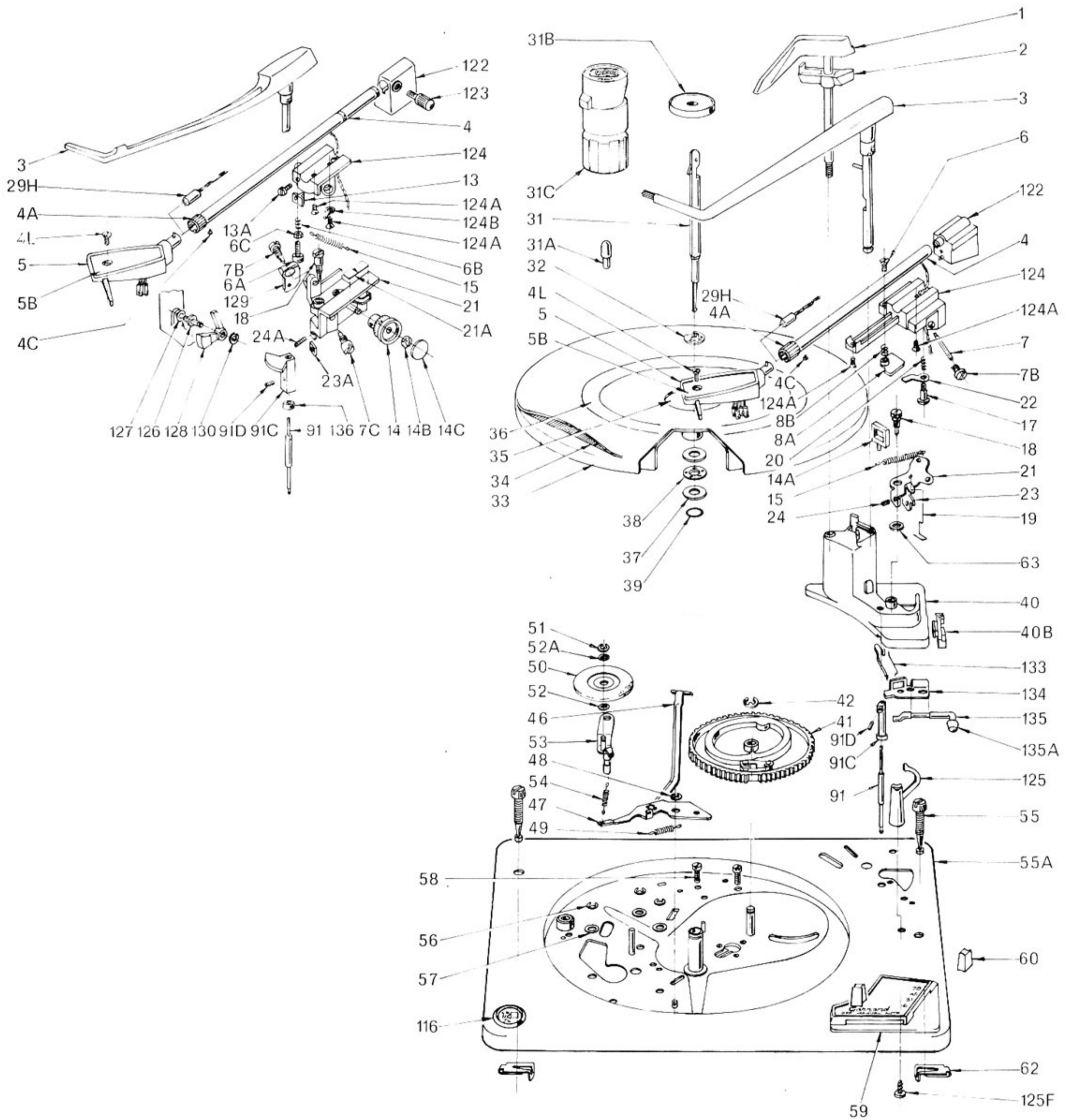

PARTS SHOWN ABOVE UNIT PLATE

Spare Parts List Models 50 Mk II, S.L.55, 60 Mk II, S.L.65

When referring to these units it is essential to quote the model type and code number. The code number is over stamped on the inspection label taped to the underside of the unit plate.

On Model 50 Mk II the code number is 72560 plus its following 3-figure stroke number.

On Model S.L.55 the code number is 73455 plus its following 3-figure stroke number.

On Model 60 Mk II the code number is 72550 plus its following 3-figure stroke number.

On Model S.L.65 the code number is 73465 plus its following 3-figure stroke number.

In addition when ordering spares, quote the part number and colour or voltage range, if applicable.

Ref. No.	Garrard Part No.	Description	Ref. No.	Garrard Part No.	Description
1	70936	Record Size Selector	15	44718	Spring (50 Mk II, S.L.55)
2	70938	Selector Extension	15	44893	Spring (60 Mk II, S.L.65)
3	72495	Overarm (50 Mk II, S.L.55)	17	40322	Screw (50 Mk II, S.L.55)
3	71056	Overarm (60 Mk II, S.L.65)	18	70954	Pivot Screw (50 Mk II, S.L.55)
4	72509	Pickup Arm, less Head and Weight (50 Mk II, S.L.55)	18	59003	Pivot Screw (60 Mk II, S.L.65)
4	72173	Pickup Arm, less Head and Weight (60 Mk II, S.L.65)	19	44711	Overload Spring (50 Mk II, S.L.55)
4A	58962	Collar	19	44928	Overload Spring (60 Mk II, S.L.65)
4C	40264	Screw	20	44705	Spring (50 Mk II, S.L.55)
4L	41776	Screw	21	72548	Pickup Bracket (50 Mk II, S.L.55)
5	70870	M7 Pickup Shell	21	72178	Pickup Bracket (60 Mk II, S.L.65)
5B	72561	Cover Plate for Shell (50 Mk II, S.L.55)	21A	72529	Marker Plate (60 Mk II, S.L.65)
5B	72538	Cover Plate for Shell (60 Mk II, S.L.65)	22	70918	Restrictor Blade (50 Mk II, S.L.55)
6	44273	Screw (50 Mk II, S.L.55)	23	71217	Locking Clip (50 Mk II, S.L.55)
6A	71878	Screw (60 Mk II, S.L.65)	23A	40906	Locking Washer (60 Mk II, S.L.65)
6B	44716	Spring (60 Mk II, S.L.65)	24	44210	Screw (50 Mk II, S.L.55)
6C	41037	Nut (60 Mk II, S.L.65)	24A	40268	Grub Screw (60 Mk II, S.L.65)
7	59993	Pivot Spindle (50 Mk II, S.L.55)	29H	71449	Pickup Lead, with Connector
7B	70155	Pivot Screw (50 Mk II, S.L.55)	31	70932	Automatic Record Spindle
7B	70585	Pivot Screw (60 Mk II, S.L.65)	31A	59830	Manual Record Spindle
7C	59756	Pivot Screw (60 Mk II, S.L.65)	31B	50391	Large Centre Hole Record Adaptor
8A	72516	Plate (50 Mk II, S.L.55)	31C	71711	L.R.S.20
8B	44892	Spring (50 Mk II, S.L.55)	32	43834	Spring Clip
13	72844	Anchor Pad (60 Mk II, S.L.65)	33	71753	Turntable with Mat and Trim Ring (50 Mk II, S.L.55)
13A	44279	Screw (60 Mk II, S.L.65)	33	72551	Turntable with Mat and Trim Ring (60 Mk II, S.L.65)
14	72185	Knob (60 Mk II, S.L.65)	33	71692	Turntable, for Plain Mat (50 Mk II, S.L.55)
14A	73013	Slider (50 Mk II, S.L.55)	34	72977	Turntable Mat and Trim Ring (50 Mk II, S.L.55)
14B	43860	Spring Clip (60 Mk II, S.L.65)	34	72747	Turntable Mat and Trim Ring (60 Mk II, S.L.65)
14C	72186	Disc (60 Mk II, S.L.65)	34	57422	Plain Turntable Mat (50 Mk II, S.L.55)

Ref. No.	Garrard Part No.	Description	Ref. No.	Garrard Part No.	Description
35	73352	Name Plate	63	40504	Washer
35	71638	Plain Centre Plate (50 Mk II, S.L.55)	91	72872	Lifting Spindle (50 Mk II, S.L.55)
36	72549	Grey Trim Ring (50 Mk II, S.L.55)	91	72869	Lifting Spindle (60 Mk II, S.L.65)
36	59396	Trim Ring (60 Mk II, S.L.65)	91A	41986	Spring
37	40894	Thrust Washer (2)	91B	40514	Washer
38	58229	Ball Race	91C	72870	Cueing Collar (50 Mk II, S.L.55)
39	58749	Cushion Ring	91C	73024	Lifting Platform (60 Mk II, S.L.65)
40	72849	Upper Casting (50 Mk II, S.L.55)	91D	44052	Screw
40	73026	Upper Casting (60 Mk II, S.L.65)	116	73195	Name Plate in Holder
40B	72746	Cueing Stop Moulding	121	73542	Spring Mounting with Damping Pads (3)
41	58328	Main Cam with Pawl and Plate	121A	70447	Damping Pad (3)
42	41788	Spring Clip	122	72584	Counterbalance Weight (50 Mk II, S.L.55)
46	71824	Tension Link	122	59080	Counterbalance Weight with Screw (60 Mk II, S.L.65)
47	71357	Tension Lever	123	58919	Screw (60 Mk II, S.L.65)
48	41723	Spring Clip	124	72512	Pickup Arm Body Moulding (50 Mk II, S.L.55)
49	41503	Tension Spring	124	72536	Pickup Arm Body (60 Mk II, S.L.65)
50	58220	Intermediate Wheel	124A	44137	Screw (2)
51	43818	Spring Clip	124B	43043	Tag (60 Mk II, S.L.65)
52	40826	Fibre Washer	125	73524	Pickup Rest with Fixing Screw
52A	40985	Nylon Washer	125F	44125	Screw for Pickup Rest
53	71545	Support Lever	126	70584	Pivot (60 Mk II, S.L.65)
54	44819	Spring	127	40649	Spacer (60 Mk II, S.L.65)
55	44120	Transit Screw (2)	128	71961	Weight (60 Mk II, S.L.65)
55A	71520	Unit Plate with Pins and Bushes	129	70845	Pin Bracket (60 Mk II, S.L.65)
56	41723	Spring Clip	130	41868	Spring Clip (60 Mk II, S.L.65)
57	40695	Washer	133	72745	Cueing Lift Bracket
58	44220	Screw (2)	134	72744	Cueing Pivot Bracket
59	72500	Control Moulding and Plate	135	73027	Cueing Lever
60	72507	Control Knob (2)	135A	72748	Knob for Cueing Lever
62	43855	Transit Screw Clip (2)	136	72868	Cueing Collar (60 Mk II, S.L.65)

Exploded View Beneath Unit Plate

Models 50 Mk II S.L.55, 60 Mk II, S.L.65

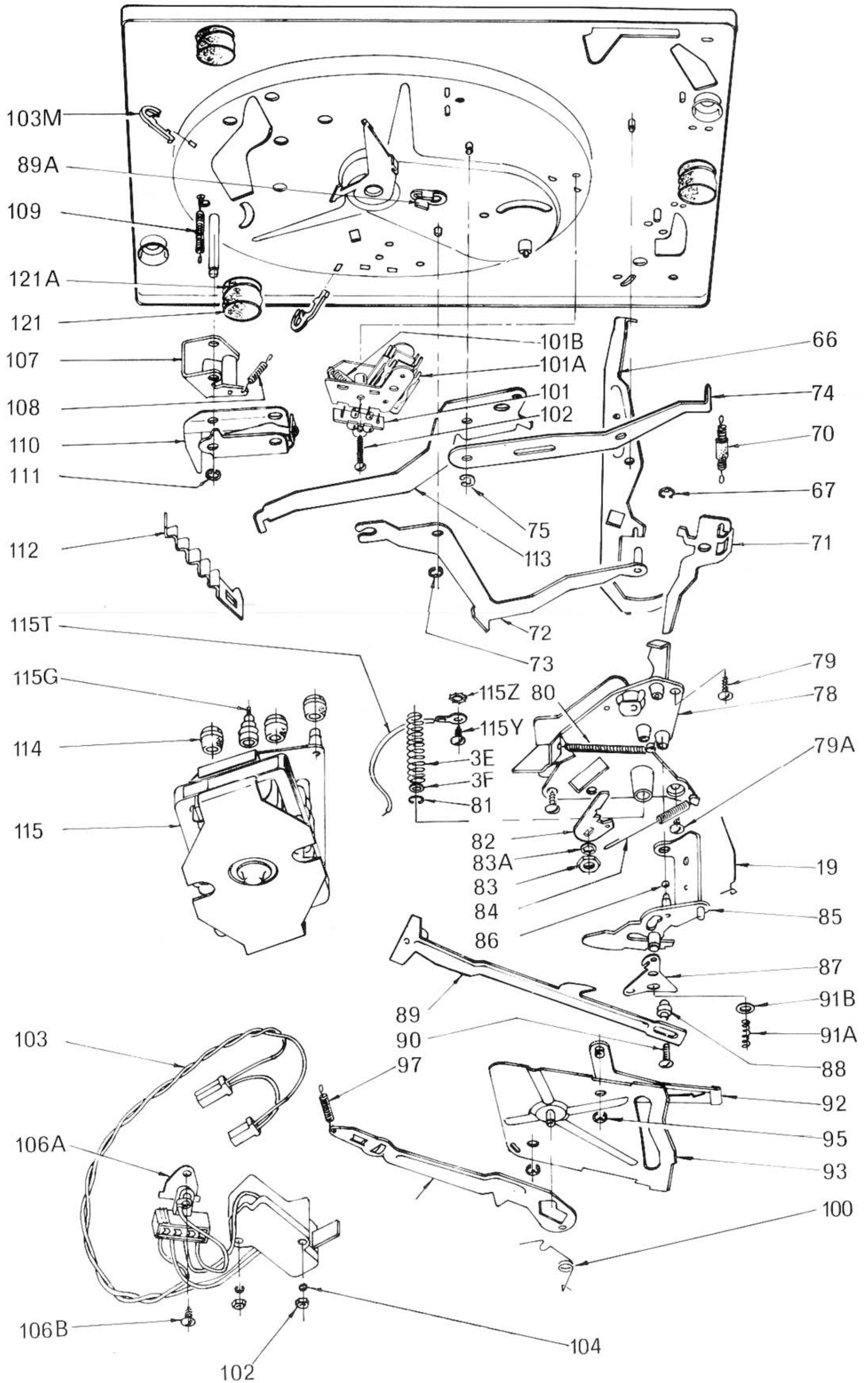

PARTS SHOWN BELOW UNIT PLATE

Spare Parts List Models 50 Mk II, S.L.55, 60 Mk II, S.L.65

When referring to these units it is essential to quote the model type and code number. The code number is over stamped on the inspection label taped to the underside of the unit plate.

On Model 50 Mk II the code number is 72560 plus its following 3-figure stroke number.

On Model S.L.55 the code number is 73455 plus its following 3-figure stroke number.

On Model 60 Mk II the code number is 72550 plus its following 3-figure stroke number.

On Model S.L.65 the code number is 73465 plus its following 3-figure stroke number.

In addition when ordering spares, quote the part number and colour or voltage range, if applicable.

Ref. No.	Garrard Part No.	Description	Ref. No.	Garrard Part No.	Description
3E	44855	Spring	93	58317	Pickup Cam (50 Mk II, S.L.55)
3F	40967	Washer	93	58958	Pickup Cam (60 Mk II, S.L.65)
66	72508	Control Lever with Knob	95	41723	Spring Clip (2)
67	41723	Spring	96	71637	Release Lever
70	71138	Return Spring with Sleeve	97	41759	Pawl Spring
71	58327	Reject Lever	100	71362	Return Spring
72	58310	Switch Lever	101	59611	Twin Phono Socket
73	41723	Spring Clip	101	58356	Tag Trip (50 Mk II, S.L.55) not shown
74	72506	Speed Control Lever with Knob	101A	71536	Muting Switch and Phono Socket (60 Mk II, S.L.65)
75	41723	Spring Clip	101A	58862	Muting Switch only (60 Mk II, S.L.65)
78	72018	Lower Casting Assembly	101B	41503	Spring (60 Mk II, S.L.65)
79	44288	Screw (2)	102	44126	Screw (50 Mk II, S.L.55)
79A	44154	Screw	102	44139	Screw (60 Mk II, S.L.65)
80	44825	Spring	103	60365	Wiring Loom for Motor with Switch
81	43813	Spring Clip	103M	71971	Clip Fixing Motor Lead (2)
82	58303	Selector Lever	104	42526	Shakeproof Washer (2)
83	41007	Nut	105	41008	Nut (2)
83A	42513	Shakeproof Washer	106A	59310	Insulation Plate
84	44706	Spring	106B	44154	Screw
85	70329	Pickup Lever	107	58211	Index Bracket, with Roller
86	43200	Ball	108	41848	Index Spring
87	41985	Friction Spring	109	44708	Lifting Spring
88	58316	Collar	110	58208	Support Bracket, with Blade
89	72681	Auto Trip Link	111	43858	Spring Clip
90	44133	Screw	112	70218	Speed Cam
91A	41986	Spring	113	58274	Speed Lever
91B	40514	Washer	114		Rubber Mount, 4-pole Motor (3)
92	58348	Friction Link	114	43140	Rubber Mount, 2-pole Motor (3)

Ref. No.	Garrard Part No.	Description	Ref. No.	Garrard Part No.	Description
115	60510	4-pole Synchro-Lab Motor	Parts not shown		
115	60350	4-pole Motor (50 Mk II, 60 Mk II)	59028		Phono Lead (Grey)
115	58570	2-pole Motor (50 Mk II only)	59029		Phono Lead (Brown)
115G	58920	4-pole Motor Pulley, 50 Hz, with Screws	71473		Line Cord, with Strain Relief
115G	58921	4-pole Motor Pulley, 60 Hz, with Screws	51333		Insulating Plate
115G	60622	4-pole Synchro-Lab Motor Pulley, 50 Hz, with Screws	58179		Cover for Voltage Changeover Block
115G	60623	4-pole Synchro Lab Motor Pulley, 60 Hz, with Screws	40367		Screw
115T	60391	Earth Lead	41012		Nut
115V	44126	Screw	40515		Washer
115Z	42500	Shakeproof Washer	42501		Spring Washer
			<p>Note: References 120B, C, G, H, J, and K are for parts of the voltage changeover block used with high and low range combined motors. In such motors, the voltage changeover block itself, is part of the wiring loom.</p>		

Speed Change Mechanism

A four-stepped pulley is used to drive the turntable via the rubber intermediate wheel unit (50). Speeds are selected by the speed change mechanism moving rubber intermediate wheel (50) to the appropriate driving step of the pulley. When the speed control lever (74) is moved to the desired speed, it pivots speed lever (113) which carries speed cam (112). Speed cam (112) lifts or lowers the rubber intermediate wheel mechanism and also motivates the index bracket (107) which retracts the rubber intermediate wheel (50) while it is changing pulley steps.

Cueing Mechanism

The cueing mechanism can be operated at any time by moving cueing lever (135), which by a camming action on cueing pivot bracket (134) lifts cueing lift lever (133). This raises the lifting spindle mechanism, which in turn lifts the pickup arm through its pickup height adjustment linkage. The pickup arm can then be aligned over a record manually and by slowly moving cueing lever (135) forward and down, the reversed cam movement lowers the pickup on to the record. On later models a diecast cam is fitted to cueing lever (135) which operates a plastic cueing lifting bracket via an adjustment screw.

The following three diagrams illustrate Model S.L.65. They serve as a reference for Model 60 Mk II, also for Models 50 Mk II and S.L.55 when used with diagram 14, which shows the Model 50 Mk II and S.L.55 pickup arm features.

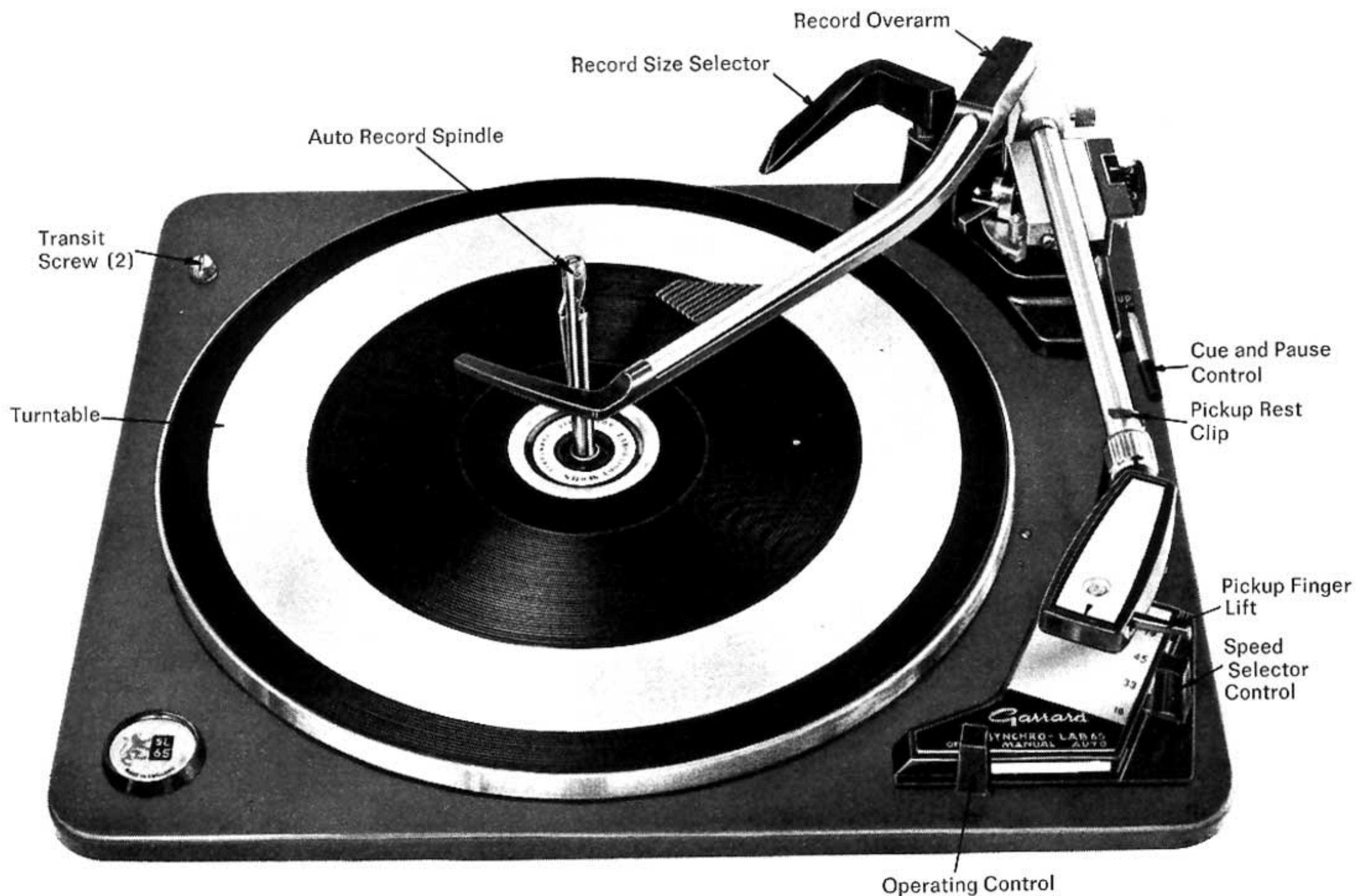

Diagram 17

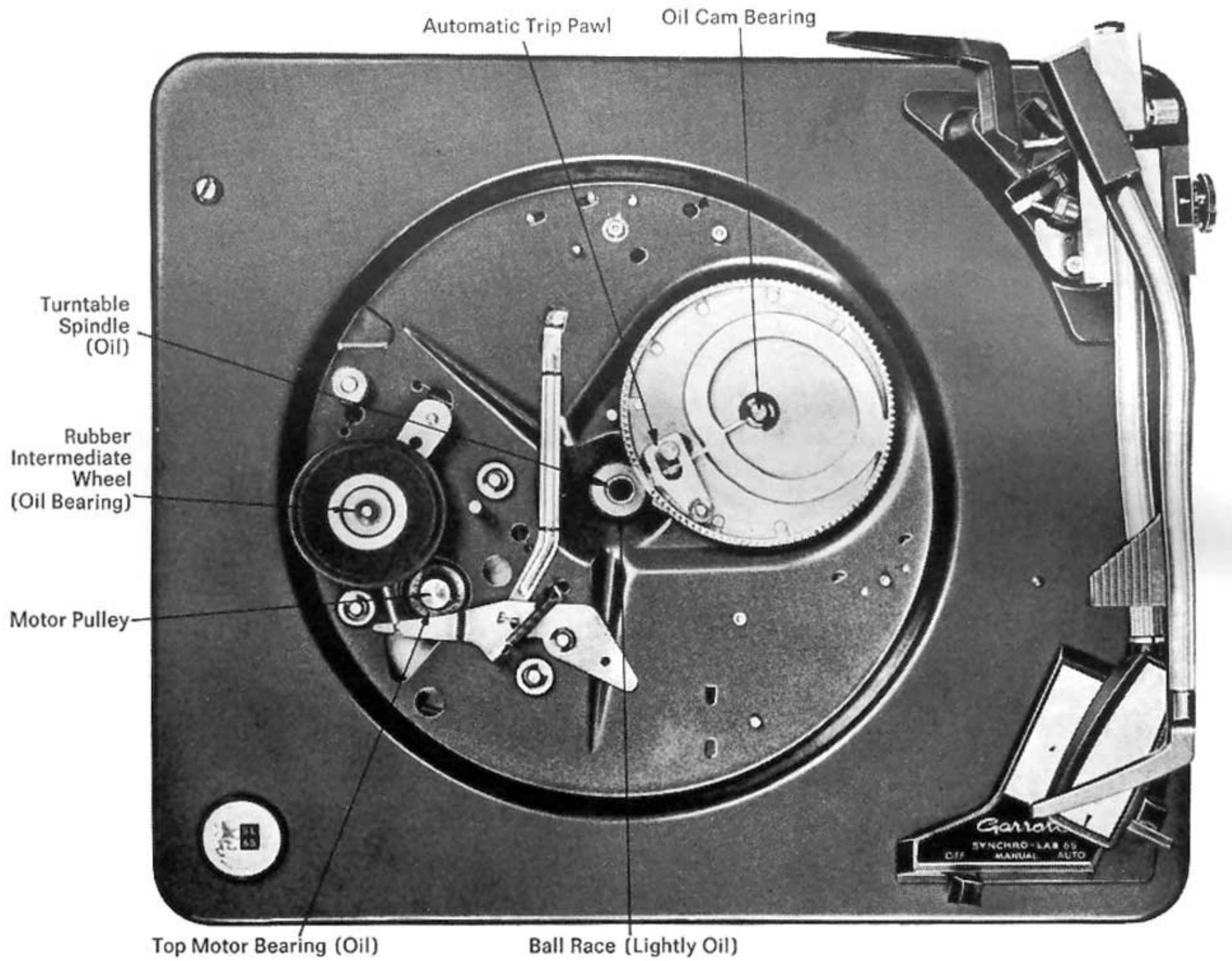

Diagram 18

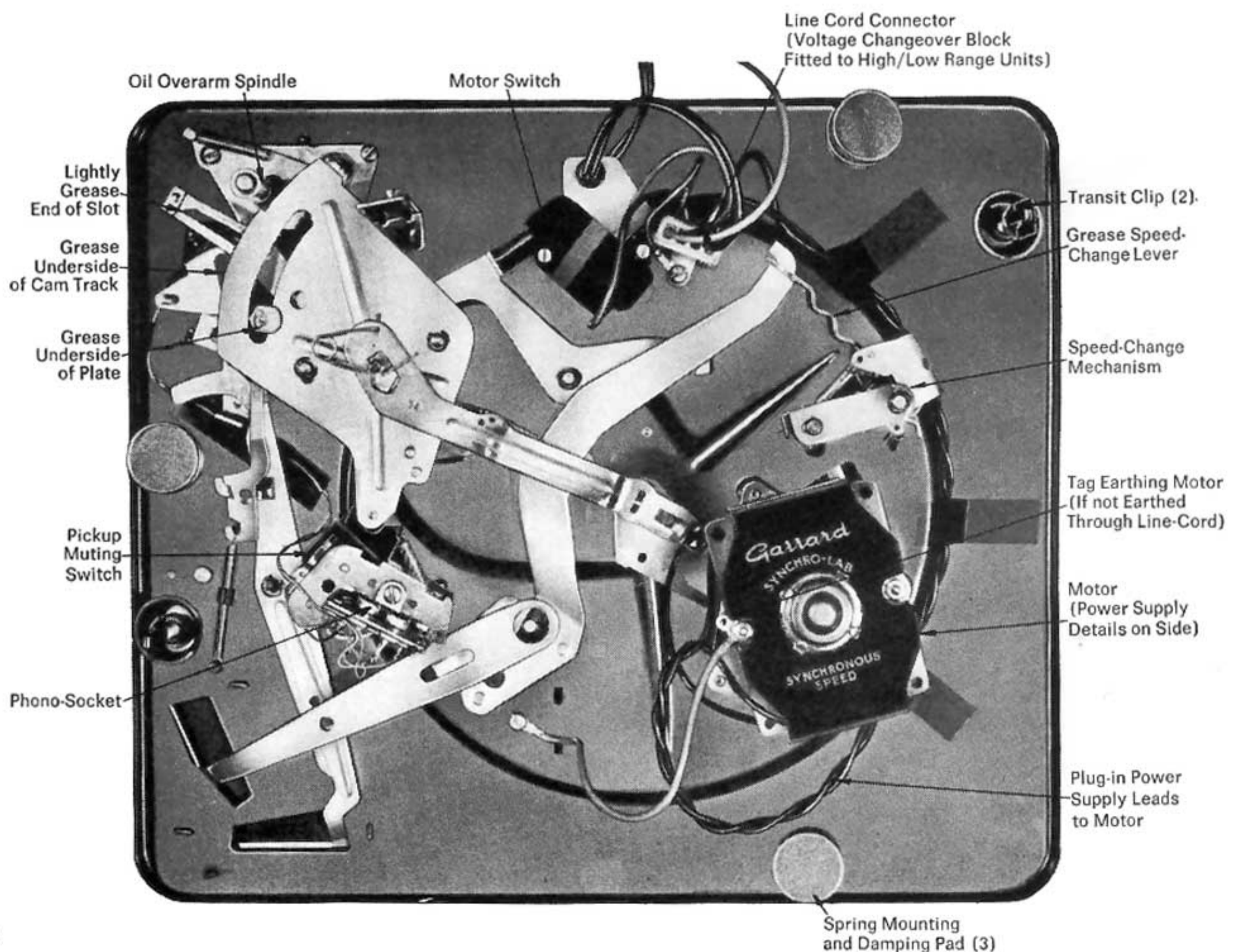

Diagram 19

DISCONNECT THE POWER SUPPLY BEFORE SERVICING A UNIT

FAULT	CAUSE	CORRECTION
Pickup remains in centre of record, or repeats in record groove when nearing centre of record.	1. Stylus force too light.	Make sure that vertical movement pivot spindle (7) is free on Models 50 Mk II and S.L.55. If necessary, lubricate with a spot of light machine oil. If Model 60 Mk II or S.L.65, make sure that ball races bearing pivot screws (7B and 7C) are clean. Check stylus force on both models and adjust as described under "Service Adjustments".
	2. Accumulation of dust on stylus or worn stylus.	Remove dust. Check stylus with magnifying glass. Replace it if worn.
	3. Pickup leads not free.	See in "Pickup Tracking" under "Service Adjustments".
	4. Pickup cartridge case (29) touching on record or record label.	Check that cartridge fixing screws (25) are tight. Then make sure that the stylus bar is not damaged.
	5. Too much friction on automatic trip links.	Guard stylus and move pickup arm slowly inward by hand. Should any stiffness be felt, check associated levers for freeness. Clean automatic trip lever (89) and bearing pad (89A).
Turntable runs excessively fast or slow.	1. Voltage range of motor set incorrectly.	Disconnect power supply and check all voltage connections. Make sure that specification on motor matches power supply. If high or low voltage range model, check changeover block connections against the information on the changeover block cover. Make sure links (diagram 2) are tight and making good contact.
	2. Incorrect motor pulley (115G) 4-pole motor only.	Remove turntable (see Maintenance) and check pulley (115G) by colour finish, nickel for 50 cycles and brass for 60 cycles power supply. If incorrect, replace it. When ordering, quote model type and frequency of power supply. Note: 2-pole motor pulley is not removable, therefore replace with new motor.
	3. Tight rubber intermediate wheel (50) bearing.	Spin the rubber intermediate wheel (50) to see if it runs freely. If not free, remove it, clean its spindle, lubricate with light machine oil and reassemble. Check that washers (52 and 52A) are in place above and below the wheel.
	4. Motor pulley (115G), or rubber intermediate wheel (50) height incorrect.	See "Service Adjustments" under "Speed". Note: If a 4-pole motor pulley (removable), check that it is set with the top of the pulley (115G) level with the top of the rubber intermediate wheel stop pin in the unit plate. Adjust by loosening grub screws (115S), if necessary to permit movement.
Speed slightly fast or slow.	1. Wrong size pulley (115G) — 4-pole motor only.	If the turntable fails to run within reasonable limits even after following the preceding instructions, time the speed of the turntable while playing a record. Send the existing pulley (115G) stating model type and turntable speed, to our Technical Service Department and your pulley will be replaced. Note: 2-pole motor pulley is not removable.

FAULT	CAUSE	CORRECTION
Speed varies erratically.	1. Oil on driving surface.	Remove turntable and clean driving surfaces (see Maintenance).
	2. Motor pulley (115G) loose or height incorrect — 4-pole motor only.	Check that pulley grub screws are tight. See “Turntable runs excessively fast or slow” — Cause 5.
	3. Motor shaft tight.	If the motor shaft is tight in its bearings it will not spin freely when spun with the fingers. This condition may be caused by too heavy a lubricating oil, or mis-aligned motor bearings. See “Motor runs slowly” — Causes 1 and 2 — for correction.
	4. Warped records slipping.	Warped records may slip if placed one on top of another. This may be overcome by sticking a small strip of adhesive tape on the offending record labels.
Speed varies consistently (Wow and Flutter).	1. Tight turntable spindle.	Revolve the turntable by hand without engaging the record changer mechanism; it should turn freely. If rough or sticky, remove the turntable (see Maintenance) and clean its bearing and spindle with a clean cloth. Oil the spindle and ball race (38) with light machine oil. Remove surplus oil.
	2. Dirt on inside of turntable rim.	Remove turntable (see Maintenance) and clean inside of turntable rim with a clean cloth.
	3. Loose motor pulley (115G) — 4-pole motor only.	See “Speed varies erratically” — Cause 2.
	4. Flats on rubber intermediate wheel (50).	Slight flats can be removed by running the unit continuously for a few hours. If this does not suffice, replace the rubber intermediate wheel (50). Avoid flats by allowing the unit to switch off automatically, for if the power point is used as a switch, the mechanism may remain in engagement, forming a flat on the rubber intermediate wheel (50).
	5. Bent shaft or unbalanced rotor.	Should the motor shaft with pulley removed (if the removable type) be more than .0005" out of alignment or the motor vibrates badly, replace the motor. (In most cases this is facilitated by plug-in connections.)
Turntable does not revolve when motor is running.	1. Oil on driving surfaces.	Remove turntable and clean driving surfaces (see Maintenance).
	2. Rubber intermediate wheel spring (54) not functioning.	Check that this spring (54) is still in place. Move the Control to “Manual” and watch to make sure that the spring (54) goes into tension. If not, it means that the spring has stretched and should be replaced.
	3. Rubber intermediate wheel support bracket (110) not free.	Check that this bracket (110) is free to move in the slot in the unit plate. The rubber intermediate wheel (50) should engage the motor pulley firmly on switching the Control to “Manual” and retract freely when switching to “Off”. If the bracket (110) is tight, check the speed change mechanism underneath the unit plate. See that none of the mechanism is damaged and lubricate the rubber intermediate wheel support spindle and speed change spindle with light machine oil.

FAULT	CAUSE	CORRECTION
Fails to switch off when last record has played, or switches off without playing a record.	<ol style="list-style-type: none"> 1. Record overarm spindle (3) not free. 2. Excessive friction on control lever (66). 3. Switch off lever on lower casting (78) stiff. 	<p>Check that the record overarm (3) when in its innermost (i.e. operating) position will drop freely under its own weight when lifted up. If not, remove spring clip (81), spring (3E) and washer (3F) if fitted, and pull out the overarm (3). Clean it, oil its spindle and replace components, checking for freeness. To reset the overarm (3) check that the rubber washers at the top of the spindle are right against the upper casting (40). Then with the overarm in its operating position and no records on the record spindle (31), check that the end of the overarm (3) is not more than $\frac{3}{4}$" below the record spindle step. Make sure the record spindle (31) is located properly.</p> <p>Check that the movement of the control lever (66) is not restricted and its associated levers are not damaged. Should any lever be damaged, repair or replace it. Grease the end of control lever (66) that operates switch lever (72).</p> <p>Check that this lever moves freely between unit plate and lower casting (78). When the tail of this lever is moved away from the pickup arm, it should return under spring pressure. For the switch off mechanism to work properly, the switch off lever tail must be square with the unit plate. If it has been bent in transit, carefully bend it square again. Apply grease as stated under "Maintenance" and in diagram 11.</p>
Pickup consistently lands too far in or out.	<ol style="list-style-type: none"> 1. Pickup dropping position requires adjustment. 2. Selector lever nut (83) loose. 3. Selector moulding (1) damaged or out of position. 	<p>See "Pickup Dropping Position" under "Service Adjustments".</p> <p>Check that nut (83) is tight to ensure that selector lever (82) is securely held.</p> <p>Check that the selector (1) arm moulding is not damaged. Check its position thus:— With no record on spindle step (31) and power turned off, switch control to "Auto" and revolve the turntable clockwise by hand. Watch record spindle pawl as it moves across the record spindle step. Stop revolving the turntable when the pawl reaches its outermost position. Then with the overarm (3) in its operating position, check that the tip of the selector arm is between $4\frac{3}{4}$" and $4\frac{1}{4}$" radius from the turntable centre. Also, move separately a 10", then a 12" record slowly down the record spindle and make sure that the selector lever (82) catches into its 10" and 12" selecting positions. If the selector (1) is faulty, it should be replaced.</p>
Erratic selection of records.	<ol style="list-style-type: none"> 1. Selector lever nut (83) loose. 2. Selector spring (84) weak or incorrectly assembled. 3. Friction link (92) requires lubrication. 	<p>Tighten nut (83).</p> <p>Move overarm (3) to operating position, then move selector arm (1), by hand, away from the turntable centre; it should return by light spring pressure. If it does not, check that selector spring (84) is correctly assembled to lower casting (78) and selector lever (82). If it has stretched, replace it.</p> <p>Make sure that the friction link (92) is not damaged; grease it along its slot.</p>

FAULT	CAUSE	CORRECTION
Records do not drop.	<ol style="list-style-type: none"> 1. Damaged record spindle (31). 2. Top of record spindle pawl rough. 3. Record overarm (3) tight. 4. Non-standard records. 5. Return spring (100) off or weak. 6. Pawl spring (97) off or weak. 	<p>Press the record spindle pawl into the spindle (31) against its spring tension. It should readily return. If it sticks, the spindle has been damaged and should be replaced.</p> <p>Lightly polish with fine emery paper, if rough, to prevent sticking.</p> <p>Oil overarm spindle (3) so that the overarm follows a stack of records downwards as dropping occurs.</p> <p>Records conforming to B.S. 1928:1965 and I.E.C. Publication 98 should be used on these units. Records with oversize centre holes or over .090" thick around the centre hole may fail to drop. Remove label flash from new records if obstructing hole.</p> <p>Check that the tail of this spring (100) goes through hole in release lever (96) and that the spring is retained on stud of pickup cam (93). If stretched, replace it.</p> <p>Check that this spring (97) is connected from the release lever (96) to the unit plate. If stretched, replace it.</p>
Two or more records drop together.	<ol style="list-style-type: none"> 1. Record spindle latch not free. 2. Non-standard records. 	<p>The latch must move up and down freely. If it sticks up while playing records, then two or more may drop together. Remove noticeable burrs from the latch with a fine file. If necessary, remove latch by driving out cross pin at top of spindle (31). Make sure that latch and its slot are smooth and that latch is flat. Lightly clinch hole to retain pin when reassembling. Carefully support record spindle (31) during this operation.</p> <p>Records conforming to B.S. 1928:1965 and I.E.C. Publication 98 should be used on these units. If records under .053" thick around centre holes are played, then two may drop together.</p>
Pickup jumps first few grooves of record.	<ol style="list-style-type: none"> 1. Stylus force too light. 2. Worn or wrong size stylus. 3. Changer not level. 4. Pickup leads not free. 5. Groove guard on record. 6. Too much friction in friction link (92). 	<p>See "Service Adjustments".</p> <p>Check that the stylus is correct for the type of record being played. Examine the stylus under a magnifying glass and replace if chipped or worn.</p> <p>Check level as described in "Pickup Tracking" under "Service Adjustments". The fully counterbalanced pickup arm on Models 60 Mk II and S.L.65 will not be affected by the level of the unit.</p> <p>See "Pickup Tracking" under "Service Adjustments".</p> <p>Some records are made with a raised rim around the edge of the record to guard the record surface. If the stylus drops too far out on the slope of this rim, it may jump across the first few record grooves. Therefore set the Pickup Dropping Position — see "Service Adjustments" — so that the stylus lands well inside the raised rim.</p> <p>Grease friction link (92) along its slot.</p>

FAULT	CAUSE	CORRECTION
Pickup arm does not lower on to record.	<ol style="list-style-type: none"> 1. Lifting spindle unit (91) sticking. 2. Pickup arm pivot not free. 	<p>With pickup arm raised, pull up lifting spindle (91) and watch for it to return readily under spring pressure. If sticking, examine beneath changer to see that no leads or mechanism foul it. Check that lifting spring (91B) has not slipped over its retaining shoulder. Lubricate lifting spindle (91) with light machine oil.</p> <p>Check pickup arm vertical movement pivots as described under "Pickup remains in centre of record" — Cause 1.</p>
Pickup begins to lower, then swings in.	<ol style="list-style-type: none"> 1. Pickup leads not free. 2. Lifting spring (91B) or friction spring (87) not working. 	<p>See "Pickup Tracking" under "Service Adjustments".</p> <p>Check that lifting spring (91B) has not slipped over its retaining shoulder and is not damaged or obstructed. Check that blue spring steel friction spring (87) is working; with the lifting spring held clear, deflecting it away from pickup cam (93) it should spring back. Replace either of these springs if faulty.</p>
Stylus fails to track.	<ol style="list-style-type: none"> 1. Dust build-up on stylus. 2. Stylus force too light. 3. Pickup arm pivot not free. 4. Worn or wrong size stylus. 	<p>Remove accumulated dust from stylus.</p> <p>See "Service Adjustments".</p> <p>Check pickup arm vertical movement pivots as described under "Pickup remains in centre of record" — Cause 1.</p> <p>Check that the stylus is correct for the type of record being played. Examine the stylus under a magnifying glass and replace if chipped or worn.</p>
Rumble.	<ol style="list-style-type: none"> 1. Motor pulley (115G) height incorrect — 4-pole motor only. 2. Lack of lubrication. 3. Faulty mounting. 4. Dirt on rubber intermediate wheel (50). 5. Rubber intermediate wheel (50) perished. 6. Out of true motor pulley (115G) — 4-pole motor only. 7. Incorrect pickup match with amplifier. 	<p>See "Turntable runs excessively fast or slow" — Cause 5.</p> <p>Remove turntable (see "Maintenance"), clean turntable spindle, bearing and ball race (38); lubricate them with a light oil. Remove any excess oil.</p> <p>Check that the spring mountings (121) hold the unit free of the cabinet surround and that the plastic foam damping pads (121A) are fitted correctly. See that the motor is free in its suspensions and not affected by the attachment of a heavy power supply cable.</p> <p>Clean the rubber intermediate wheel (50) with a cloth, or scrape the driving surface lightly to remove any impregnated dirt.</p> <p>Should the rubber intermediate wheel (50) have hardened, showing cracks on its surface, replace it.</p> <p>Make sure that the two fixing grub screws (115S) are equally tightened. See "Turntable runs excessively fast or slow" — Cause 5.</p> <p>Make sure that pickup matching circuit is to amplifier manufacturer's recommendations.</p>

FAULT	CAUSE	CORRECTION
Interference on reproduction.	<ol style="list-style-type: none"> 1. Bad switch (103) contact. 2. Loose power supply lead connections. 3. Loose pickup cartridge connections. 	<p>Switch off the power supply and remove cover from switch. Check leads are securely soldered, contacts are clean and close when the control is moved to "Manual". To do this, it may be necessary to screw temporarily the switch to the unit plate without the cover on.</p> <p>Examine all connections to make sure of good electrical contact. If a high and low voltage model, check that the voltage changeover links are tight on their studs. Scrape any tarnish causing bad contact from the studs. See the links are set to the correct voltage as shown on the changeover block cover.</p> <p>Check that the pickup leads are securely soldered to the pickup cartridge tags and tagstrip (101). See appropriate diagrams 3, 4, 5 or 6. Also check the continuity of the leads by removing the tags from the cartridge and checking the circuit from the tags to the tagstrip. Do not solder direct to the cartridge as heat may damage the elements.</p>
Mechanical noise.	<ol style="list-style-type: none"> 1. Lack of lubrication. 2. Flats on rubber intermediate wheel (50). 3. Loose lever. 	<p>See "Rumble" — Cause 2.</p> <p>See "Speed varies consistently (Wow and Flutter)" — Cause 4.</p> <p>Eliminate buzz or chattering noise by checking each lever in turn, damping it with a finger. A spot of light oil on pivots and points of contact should remedy the trouble when the offending lever is found.</p>
Motor will not start.	<ol style="list-style-type: none"> 1. No power supply. 2. Loose connections. 3. Bad switch contact. 4. Open circuit coils. 	<p>Check that the current is reaching the motor.</p> <p>See "Interference on reproduction" — Cause 2.</p> <p>See "Interference on reproduction" — Cause 1.</p> <p>Check coils (115) for continuity using an ohm-meter, removing plug-in leads from motor, if fitted. Replace the motor if necessary.</p>
Motor runs slowly.	<ol style="list-style-type: none"> 1. Motor lubrication. 2. Motor bearings out of line. 3. Motor coils (115) incorrect polarity — 4-pole motor only. 4. Motor coil(s) open circuit. 	<p>The rotor shaft should spin freely by hand. If not, a too thick or congealed oil may have been used. Dismantle the motor and clean bearings and rotor shaft. Lubricate with thin machine oil and reassemble.</p> <p>If rotor shaft will not spin freely, although properly lubricated, tap the body of the motor with a piece of wood such as a screwdriver handle, to shock the self-aligning bearings into line and free the rotor shaft. If this is ineffective, replace motor.</p> <p>The polarity of the poles on which the coils (115) are assembled should be the same. If the motor runs slowly, check polarity and if necessary change over the leads to one coil. (If a plug-in connection, change over the leads in one plug.)</p> <p>The two coils (4-pole motor) or two windings of the single bobbin (2-pole motor) are connected in parallel to run on low voltage on the dual voltage model. If one coil or winding becomes open circuit, the motor will still run, but slowly. Check coil continuity as stated under "Motor will not start" — Cause 4. On single voltage range models, the coils are connected in series.</p>

FAULT	CAUSE	CORRECTION		
Motor runs hot.	5. Motor frequency wrong. (50 or 60Hz.)	Check motor pulley colour finish, see "Speed" under "Service Adjustments". A motor running on a frequency lower than the correct motor frequency will run slow and a motor running at a frequency higher than the correct motor frequency will run fast.		
Motor runs hot.	1. Normal running conditions.	Provided the motor current does not exceed the following figures at the voltage stated, the temperature of the motor should not rise above its designed running temperature.		
	MOTOR			
	Power	2-pole	4-pole	Synchro
	Supply			Lab
	115 volts 60 Hz	0.16 amp	0.1 amp	0.15 amp
240 volts 50 Hz	0.09 amp	0.16 amp	0.08 amp	
Although Garrard motors are designed to run under un-ventilated conditions, as much ventilation as possible is beneficial.				
2. Short circuit in coil(s).	Check the windings for short circuit with an ohmmeter; see "Motor will not start" — Cause 4.			
3. Incorrect voltage.	Check that voltage specification on motor corresponds to voltage of the power supply. If supply voltage is too high, the coil may burn out. If a voltage changeover block is fitted, check that its links are set correctly.			
4. Insulation leakage to earth.	Test insulation between windings and frame with a 500 volt insulation test meter; it should not be less than two megohms. It is recommended that the motor be earthed from its earthing tag to a good earthing point.			



Garrard L.R.S.20 illustrated above
Allows up to 8 large centre hole 7" diameter records to be played in automatic sequence on these units.

