

Garrard

**SERVICE MANUAL FOR
SL 75 AND SL 95**



AUTO TRANSCRIPTION TURNTABLES

**GARRARD ENGINEERING LIMITED
NEWCASTLE STREET
SWINDON - WILTSHIRE - ENGLAND
Telephone: Swindon 5381**

Contents

Index	Page 3
General Information	Page 3
Installation	Page 4
Wiring	Page 5
Fitting Pickup Cartridge	Page 6
Installation Adjustments	Page 7
Operating Instructions	Page 8
Maintenance and Adjustments	Page 10
Parts Lists and Exploded Views	Page 11
Lubrication	Page 20
Fault Charts	Page 23

General Information

This manual provides instructions for servicing the Garrard Synchrono-Lab 75 and Synchrono-Lab 95 Automatic Transcription Turntables. The SL 75 and SL 95 are 3-speed transcription turntables with facilities for automatic record playing if required. This manual applies to both units except where special reference is made.

The units automatically play up to six 12" records at 33½ or 78 rpm or up to six 7" records with large centre holes at 45 rpm using large record spindle LRS 25 (an optional extra). They will also automatically play a single record loaded manually, and any standard record can be played manually or by using the cue and pause control. Any record can be rejected or interrupted and a single record or the top record of a stack can be replayed. The pickup will return to its rest and the unit will automatically switch off when the last record has played (see operating instructions).

Both models are driven by the Garrard Synchronous Motor which runs at a constant speed. The pickup arms have resiliently mounted counterbalance weights and stylus force is applied by turning a dial calibrated between 0 and 5 grammes. Removable slide-in cartridge carriers accepted cartridges with standard fixing arrangements and calibrated pickup arm bias compensators to counteract side pressure on the stylus are also fitted to the pickup arms. Pickups can be raised and lowered steadily by means of a built in cue and pause device, the action of which is damped by a special viscous fluid.

The 11½" turntable is of double construction with an inner driving turntable and a non-magnetic outer turntable of large diameter.

The special record supporting platform can be retracted for manual play and raised for automatic play.

Both units float on four foam damped mounting springs to counteract the effects of extraneous vibrations and acoustic feedback.

Before connecting the unit make sure that the power supply is as shown on the motor. If the pickup circuit of the unit is connected to an amplifier whose wiring is not isolated from the power supply, isolating components, either capacitors or transformer, should be incorporated in the pickup circuit; otherwise the pickup circuit can become live.

Always disconnect the power supply and protect the stylus before servicing a unit.

Garrard record playing equipment is made to play records complying with BS 1928/1965 and IEC Publication 98, also other similar standards.

If you have occasion to ask for spare parts, please quote the model number of the Garrard unit and the reference numbers on the coloured label attached below the unit plate.

Installation

Cabinet Space

Model SL 75 is 15 $\frac{5}{8}$ " wide (395.5 mm) x 14 $\frac{1}{8}$ " deep (357 mm) x 4 $\frac{3}{8}$ " (111 mm) above top of mounting board and 2 $\frac{1}{8}$ " (74.5 mm) below top of mounting board.

Model SL 95 is 15 $\frac{5}{8}$ " wide (389 mm) x 14 $\frac{1}{8}$ " deep (359 mm) x 4 $\frac{3}{8}$ " (111 mm) above top of mounting board and 2 $\frac{1}{8}$ " (74.5 mm) below top of mounting board.

These dimensions allow for the maximum overhang of the pickup arm counterbalance weight, and transit position **but in addition to the above dimensions there should be clearance of at least $\frac{1}{4}$ " (6.5 mm) all round the unit for free movement.** The board size may also be larger to suit individual requirements around the control area and give extra space for record handling, depending on the type of cabinet. See also cabinet space details on template.

Unpacking

Remove the unit from its carton according to the instructions on the carton flaps, taking care that all accessories are unpacked from the support mouldings and that all packing ties are stripped from the unit. See diagrams 1(a) and 1(b).

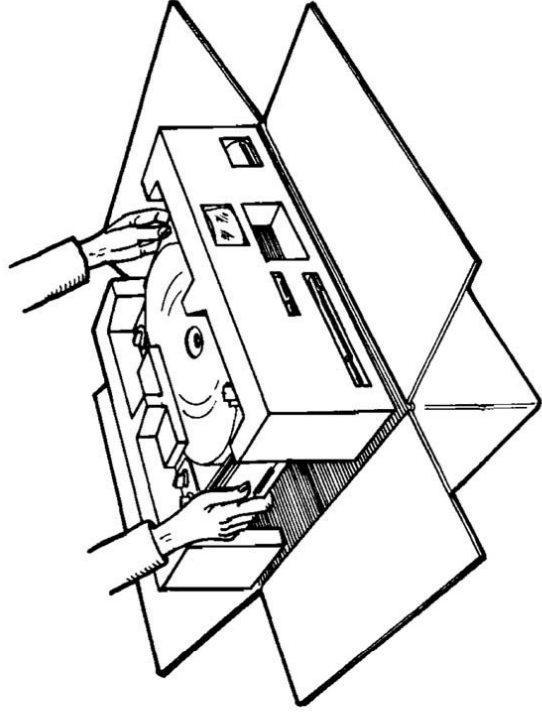

Diagram 1(a) Removing unit from carton

Fitting

1. Drill and cut out mounting board to template (fix template to board with adhesive tape). If the mounting board is thicker than $\frac{1}{2}$ " both the transit screw holes must be recessed from underneath to at least 1 $\frac{3}{8}$ " diameter (28.5 mm) to reduce board thickness to $\frac{1}{2}$ " (12.5 mm).
2. Attach power supply, earth and audio leads so that when the unit is in position they will not restrict its free movement on its mounting springs. See 'Wiring' section.
3. Screw transit screws right down, set locking clips vertical and check that damping pads are fitted in mounting springs, then place unit on board, locating mounting springs in their recesses. See diagrams on template.
4. When the unit is in place, press it down on its springs, then turn transit screw clips horizontal. (Note: During transportation the transit screws should always be turned counterclockwise to clamp unit against board and the record platform should be set in its raised position.)
5. Check that turntable mat and centre disc are located concentrically then insert the chosen record spindle in the turntable centre, rotate it until its location is felt, then press firmly to secure it in position.

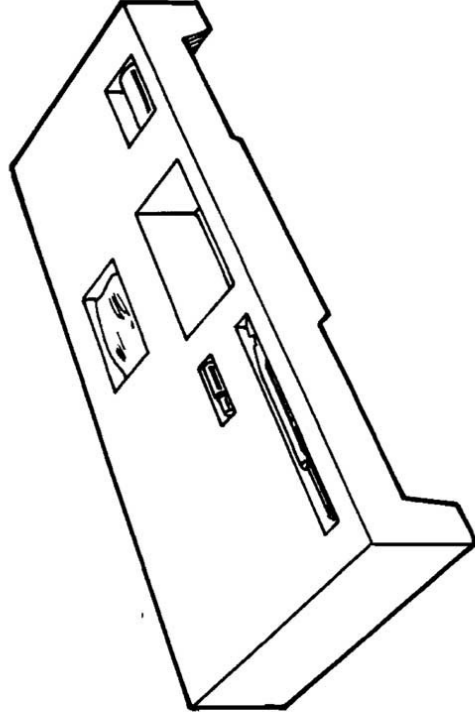

Diagram 1(b) Location of accessories in carton

6. If a pickup cartridge is to be fitted, see 'Fitting Pickup Cartridge' section, page 6.
7. Attach counterbalance weight by sliding it onto end of pickup arm (check locking screw loosened on SL 95) and make installation adjustments as described on page 7 and diagrams 6 or 7.

Wiring

These units may be supplied as single voltage range models for 110/125 volt AC, or as dual voltage range models for 110/125 and 220/250 volts AC. The voltage range of the latter model is set according to the position of the two wire links in its combined voltage changeover and power supply connecting block. See diagram 2, or cover of block.

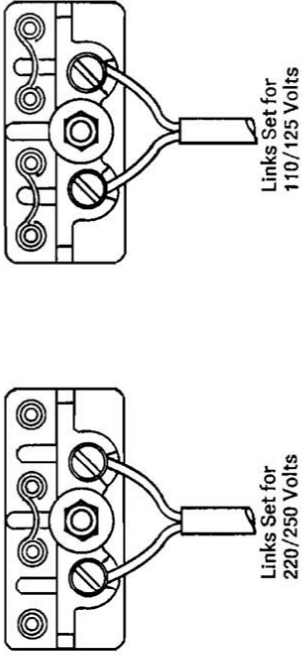

Diagram 2

The units can be used on either 50 or 60 Hz power supplies, depending on the size of the motor pulley fitted. These interchangeable pulleys are colour finished for identification, nickel for 50 and brass for 60 Hz power supply.

Power Supply Leads (Line Cords)

If a line cord, or socket, is fitted, make appropriate connections to 110/125 volts, AC 60 Hz power supply. See diagram 3. If a dual voltage changeover block is fitted, attach a suitable lead from its terminals to the power supply, first checking that changeover links are set to the correct voltage. See diagram 2.

Earth (Ground) Lead

If a line cord is fitted, earth the unit from the appropriate (Green lead) terminal in the socket, otherwise attach a lead between a good earthing point and the earth tag adjacent to the motor, or where the green motor earth lead is connected to the unit plate.

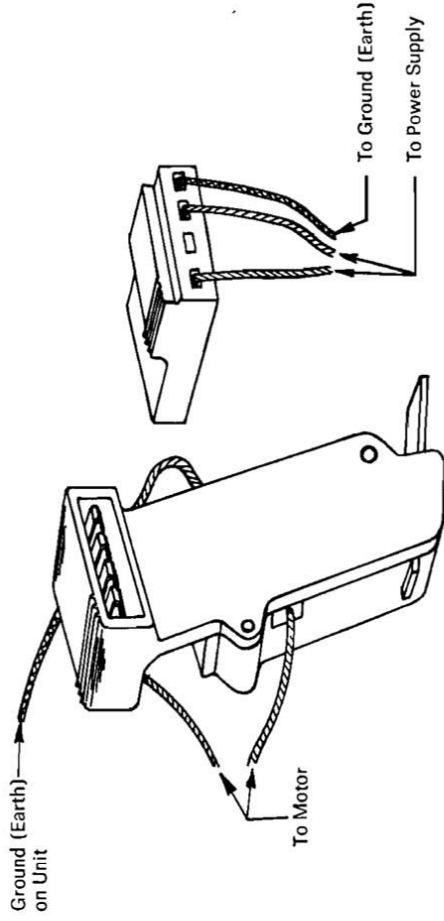

Diagram 3

Audio (Phono) Connections

If a phono socket/muting switch is fitted, connect phono leads to amplifier from sockets. A colour code of brown phono lead from amplifier right channel to phono socket right channel (marked R), and grey phono lead from amplifier left channel to phono socket left channel (marked L) is used. See diagram 4. Where tag connections are to be made, all Garrard pickup leads are colour coded to the following standard and connections should be made to the lead terminals as follows:

Red - Right Channel, **Green** - Right Channel Ground, **White** - Left Channel, **Blue** - Left Channel Ground.

Note:— When a mono cartridge is fitted use only the **Right** channel. When a stereo cartridge is used with a mono amplifier, it is advisable to parallel the two channels.

If your unit is connected to an amplifier whose wiring is not isolated from the power supply, isolating components must be incorporated in the pickup circuit.

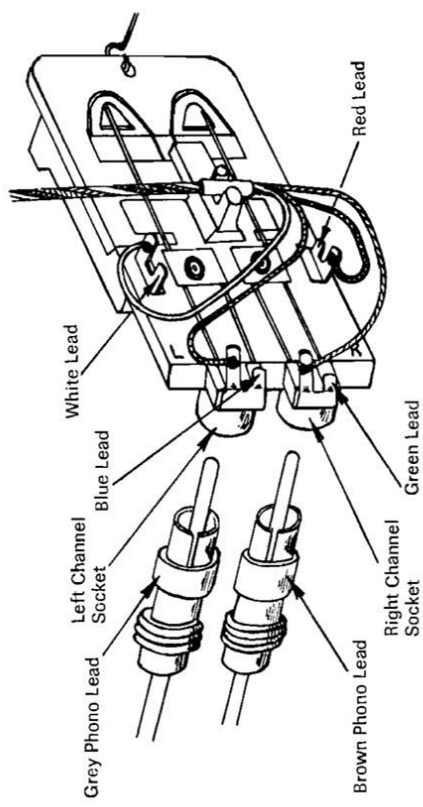

Diagram 4

Fitting Pickup Cartridge

A slide-in cartridge carrier, designated type C1, is used in the SL 75 pickup head and carrier C2, in the SL95 pickup head. If a cartridge is to be fitted, the carrier can be withdrawn by sliding it from the front of the head (lift arm to avoid control knob if necessary) and any of a wide range of cartridges can then be fixed to it, using the items in the pickup cartridge hardware kit. Use the fixing screws of the appropriate length to secure the cartridge centrally to the carrier; insert spacers (A) between cartridge and carrier if necessary. A balance weight (B) is available if a particularly lightweight cartridge is used which cannot be counterbalanced.

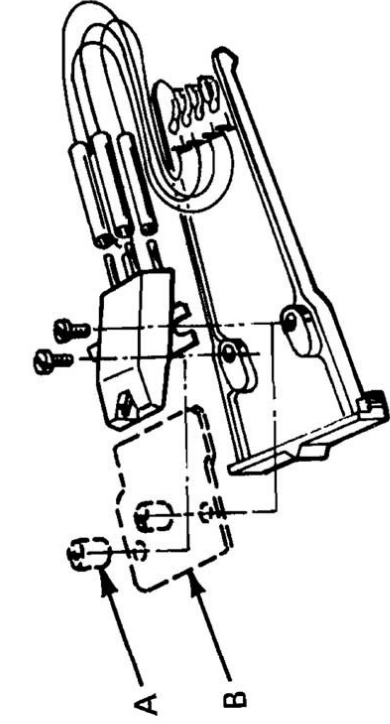

Diagram 5a Pickup cartridge assembly SL 75

Connect the pickup leads on the carrier to the cartridge, linking the colour code given on page 5 to the information supplied with the cartridge. See also diagrams 4 and 5. If there are socket connections, a suitable connector should be used. On no account solder leads directly to the tags on the cartridge. For cartridges having three connections, use the green pickup lead as the common or join the green and blue together to use as common. Insulate then tuck away any leads not required. Align the assembled cartridge carrier with the pickup head and carefully slide it back in position.

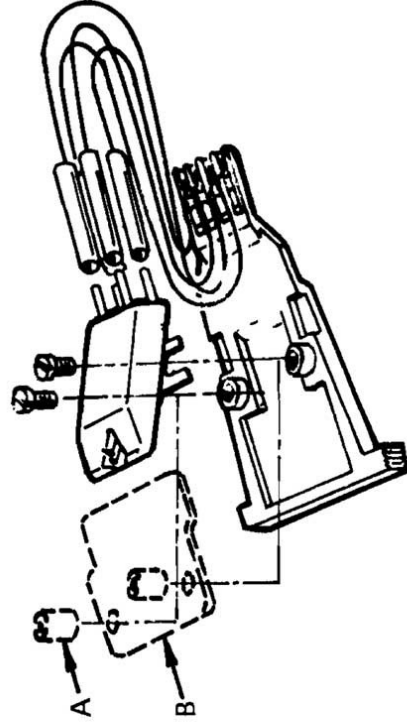

Diagram 5b Pickup cartridge assembly SL 95

Installation Adjustments

Stylus Force

Set stylus force dial to zero, then check that the auto play mechanism is not engaged by rotating the turntable clockwise by hand until free running. Unclip the pickup arm safety catch and with the arm off its rest and free to pivot, position the counterbalance weight, using its adjusting wheel for SL 75, or sliding it for SL 95, so that the pickup arm is in balance. Reclip the arm on its rest, then turn the stylus force dial to apply the force recommended by the cartridge manufacturer. The graduations of the dial represent 0 to 5 grams and on model SL 95 there are audible clicks at approximately $\frac{1}{4}$ gram intervals. See diagrams 6 and 7.

Pickup Arm Bias Compensator

To use the bias compensator, it must be engaged as in diagram 6 (SL 75) or diagram 7 (SL 95). Unlike the compensator of the SL 95, that of the SL 75 can be disengaged and, if it is desired to engage (or disengage) the compensator, the pickup arm must be moved in manually towards the turntable centre, to enable the drive arm of the compensator to be moved in or out of engagement.

To set the bias compensator, the moveable weight on the numbered carrier arm must be positioned with its 'window' over the number corresponding to that set on the stylus force dial.

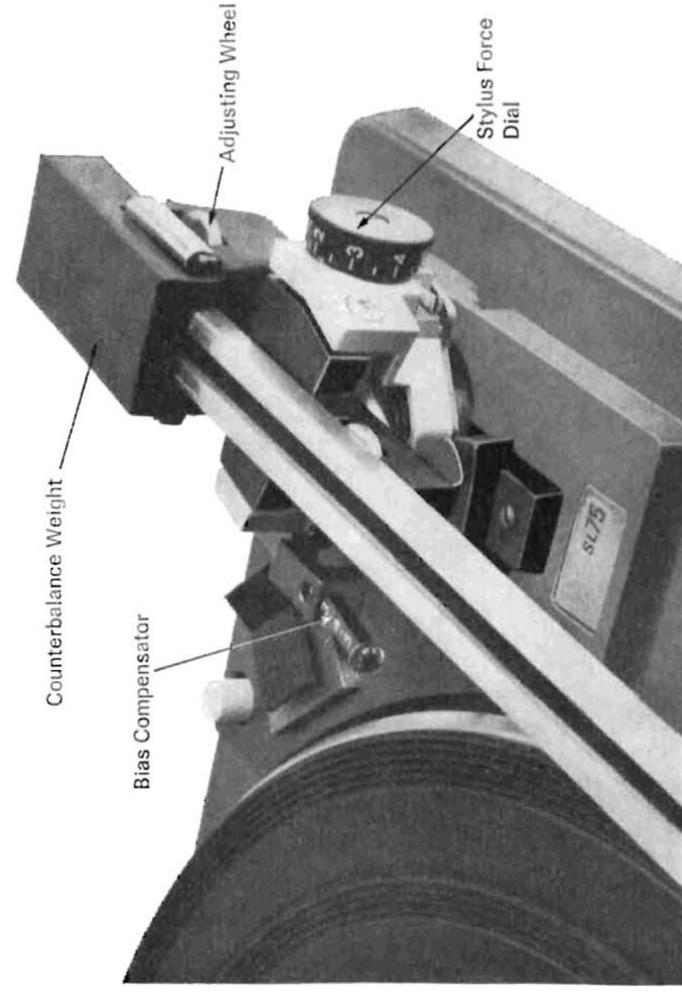

Diagram 6 (SL 75)

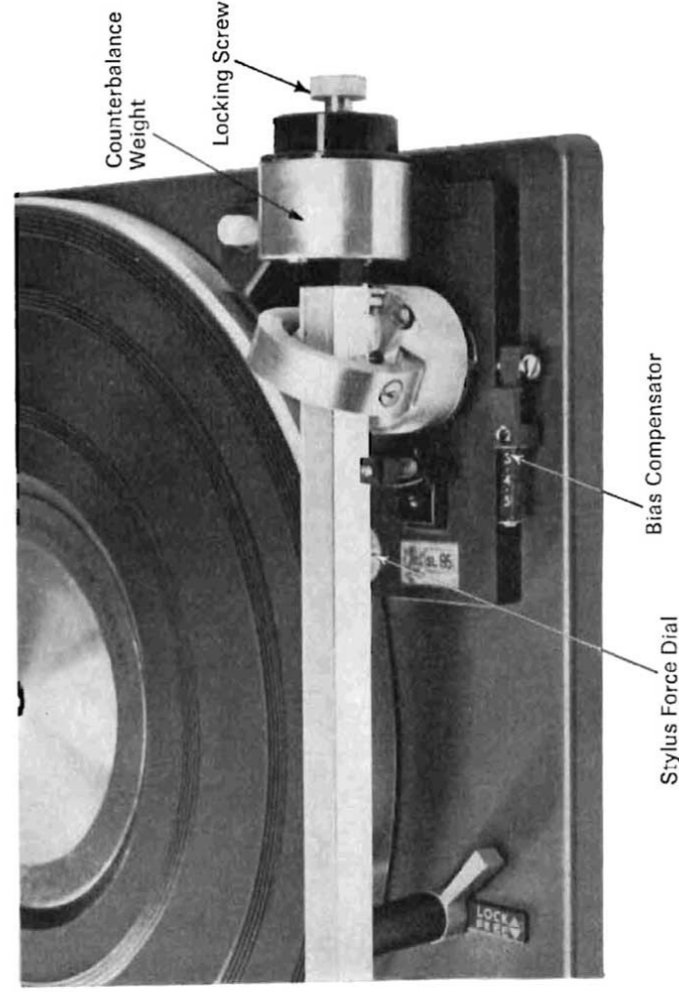

Diagram 7 (SL 95)

Operating Instructions

Automatic Play:

1. Release pickup rest safety catch, remove stylus guard if fitted and check that stylus is correct for type of record to be played. Press record platform release button if platform is retracted.
2. Set speed/size selector control to the desired position.
3. Load up to six 12" records locating them on record spindle step and platform. Clip the record steady to the edge of the record stack. (To play 7" records with large centre holes, turn control to 7" - 45 position, fit large record spindle LRS 25 (optional extra) over auto spindle and load records, locating on spindle steps only.)
4. Switch on by turning auto control to **START**. After playing all records, the pickup will lift, return to its rest and the unit will switch off. Do not switch on when no records are on unit.

To Unload:

1. Lift records clear of spindle, even if replaying the same

records. (If using LRS 25, lift records with thumbs pressing down on spindle top.)

Single Record Auto Play:

1. Fit short manual spindle in place of automatic record spindle. (For a 7" large centre hole record, fit large hole adaptor over manual spindle.)
2. Follow **Automatic Play** instructions above but press down the record steady to retract the record platform, if desired, then place the record directly onto the turntable.

Manual/Cueing Play:

1. Fit short manual spindle, release pickup rest safety catch and remove stylus guard if fitted. Check stylus suits type of record. Press down record steady to retract platform if desired.
2. Set speed/size selector control to chosen speed.
3. Place record on turntable.



Diagram 8

4. Switch on by turning manual/cueing control to **PLAY**.
5.
 - a) For normal play, place pickup on record.
 - b) To cue, turn manual/cueing control to **LIFT**. The pickup will lift and can be positioned over any point on the record. Gently turn the control back to **PLAY** and the pickup will lower.

After playing the record the pickup will return to its rest and the unit will switch off.

Repeat:

Any single record, or the last record of a stack, can be replayed by turning the auto control to **START** during play.

Pause:

A record can be interrupted by turning the manual/cueing control to **LIFT**. The pickup will lift but the turntable will continue to revolve. Gently turn the control back to **PLAY** and the pickup will lower.

Reject:

Any record of a stack being played, except the last, can be rejected by turning the auto control to **START**. The last record of a stack or any record being played manually, can be rejected by turning the auto control to **STOP**.

Stop:

Turn the auto control to **STOP**, when playing any record, and the pickup will return to its rest and the unit switch off. (If records are loaded on the spindle, the next record will drop before switch off.)

Alternatively turn the manual control to **OFF** and the unit will switch off, leaving the pickup on the record.



Diagram 9

Maintenance and Adjustments

See also Installation Adjustments.

To obtain best results from records, store and clean them as recommended by the record manufacturers. Do not leave records on the unit when not in use. Keep the stylus free from accumulated dust and replace when worn. Before carrying out any adjustments or servicing, always switch off power supply and protect pickup stylus; if necessary operate controls and rotate turntable clockwise by hand to actuate the cycling mechanism.

Pickup Lowering Position:

This setting governs the radius at which the pickup lowers onto a record when on automatic play. Turn screw in diagram 10 (SL 75) or 11 (SL 95) clockwise to move pickup lowering position inwards and counterclockwise to move it outwards, if necessary.

Pickup Height:

This adjustment controls the height which the pickup lifts on automatic play and normally should be $\frac{3}{4}$ " between the stylus tip and the top face of one record on the turntable as the pickup returns to its rest. Turn knurled screw in diagram 10 (SL 75) clockwise to decrease pickup height, counterclockwise to increase, or screw in diagram 11 (SL 95) clockwise to increase pickup height, counterclockwise to decrease.

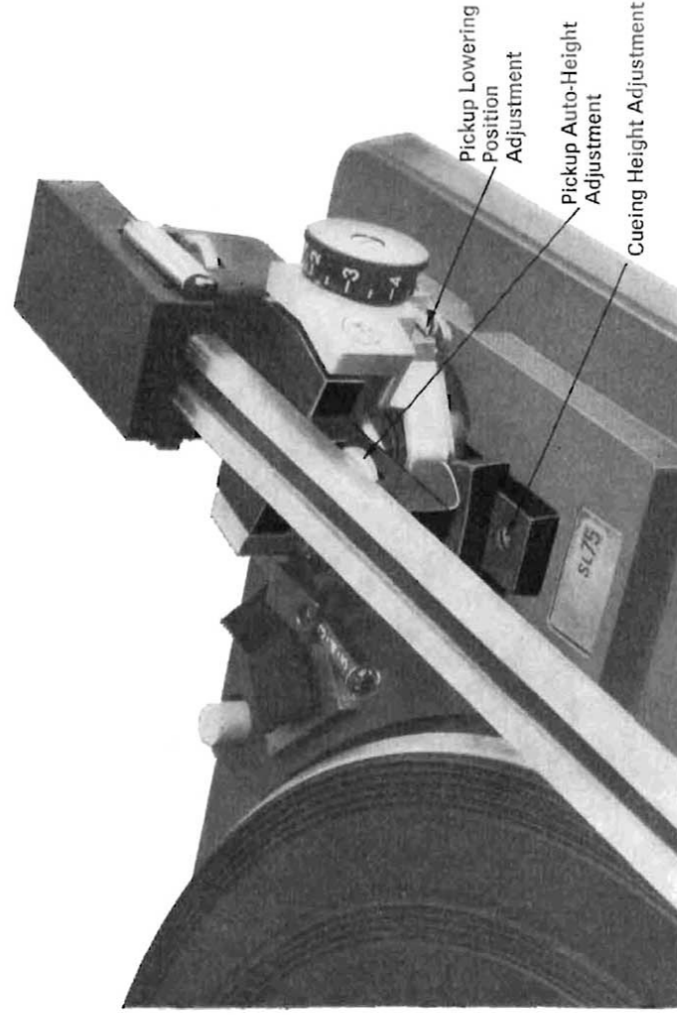

Diagram 10 (SL 75)

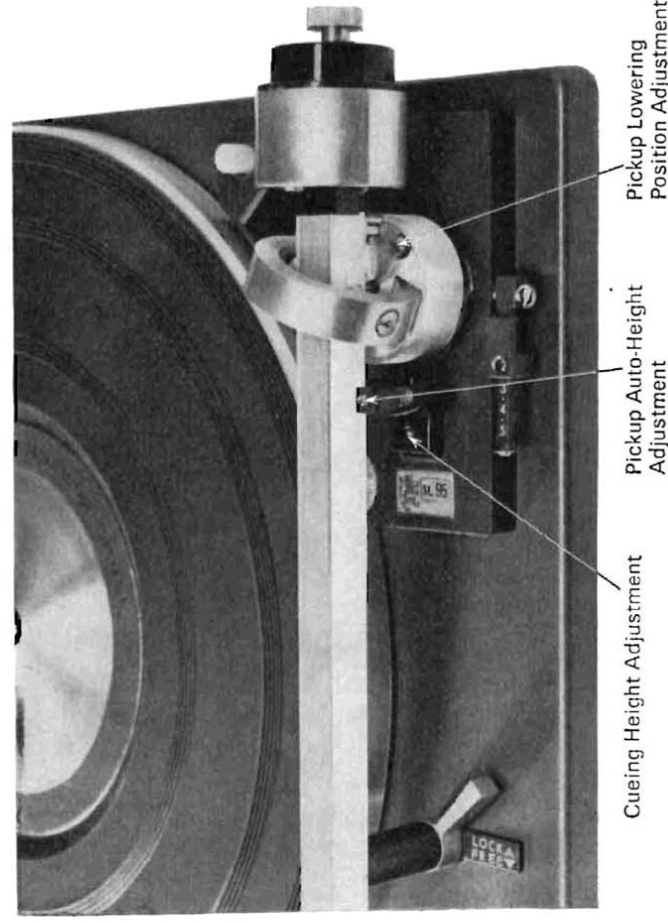
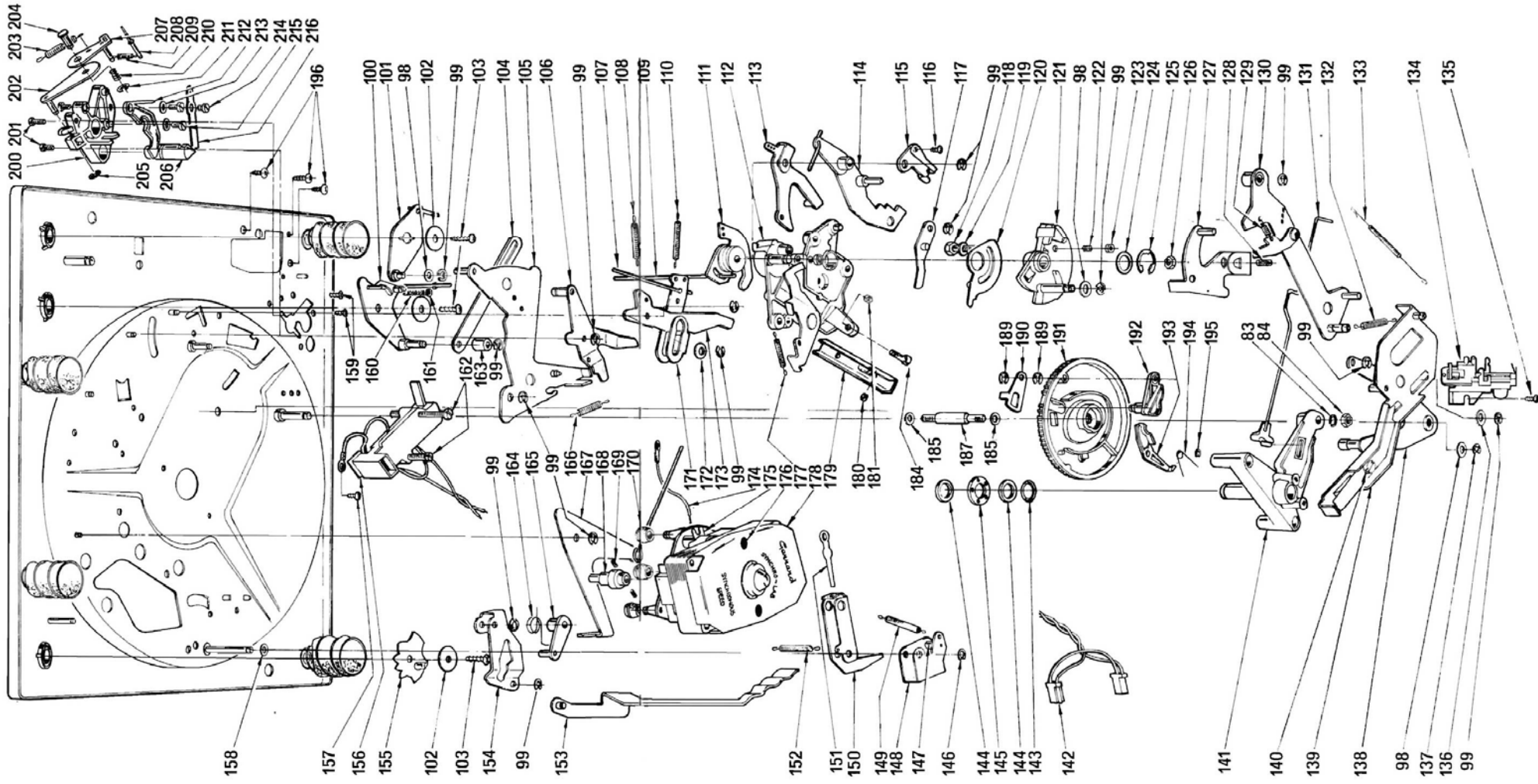

Diagram 11 (SL 95)

SL 75 • SL 95 UNDERSIDE VIEW



EXPLODED VIEW PARTS BENEATH UNIT PLATE

Ref	Part No.	Description	Ref	Part No.	Description
98	40695	Washer (Standard)	154	72354	Speed Lever
99	41723	Spring Clip (Standard - see also 105A)	155	72361	Selector Cam
100	72215	Manual Control Lever	156	73599	Insulating Plate
101	72212	Auto Control Lever	157	44126	Screw
102	40973	Washer (3)	158	40537	Washer
103	44214	Screw (3)	159	44276	Screw (2)
104	73592	Stop Link	160	44929	Spring
105	73073	Switch Lever	161	40607	Washer
105A	41787	Spring Clip for Switch Lever (labelled as 99)	162	44220	Screw (2)
106	73595	Catch Lever	163	72470	Roller
107	72264	Reject Link	164	44927	Torsion Spring
108	44948	Spring	165	72366	Index Lever
109	73756	Cueing Link	166	41506	Switch Spring
110	44718	Spring	167	72445	Selector Follower, with Link
111	72898	Cueing Cam	168	60534	60 Hz Motor Pulley with screws
112	72272	Pickup Base	168	60536	50 Hz Motor Pulley with screws
113	73495	Switch off Return Lever Unit	169	44052	Screw (2)
114	72281	Selector Lever	170	43129/001	Motor Mount (2)
115	72278	Link Guide	170	43129/002	Motor Mount (1)
116	44034	Screw	171	72441	Trip Operating Lever
117	72467	Retracting Lever	172	40695	Washer
118	44266	Screw	173	72260	Trip Lever
119	40975	Friction Washer	174	60391	Earth Lead
120	72421	Pickup Friction Lever	175	42932	Earth Tag
121	73505	Pickup Cam	176	44242	Screw (2)
122	44975	Spring	177	44951	Spring
123	72435	Friction Adjustment Nut	178	60510	Motor, Synchronous (State voltage)
124	40976	Washer	179	72287	Support Leg
125	41764	Spring Clip	180	70806	Grommet
126	41006	Nut	181	41012	Nut
127	72414	Pickup Lever	184	40155	Screw
128	44041	Screw	185	40537	Washer (2)
129	44963	Spring	187	72233	Cam Stud
130	73504	Cam Link	189	41723	Spring Clip (2)
131	72324	Trip Rod	190	58335	Trip Pawl
132	41631	Spring	191	72240	Main Cam
133	44950	Spring	192	72237	Friction Lever Unit
134	72401	Muting Switch and Phono Socket	193	72404	Cam Index Lever
135	44154	Screw	194	44973	Retaining Spring
136	40864	Washer	195	43864	Spring Clip
137	43800	Spring Clip	196	44276	Screw (3)
138	72328	Cam Lever	200	73398	Platform Base
139	72332	Release Lever	201	00245	Screw (3)
140	40023	Screw	202	73411	Support Lever
141	73292	Turntable Spindle Housing	203	41848	Spring
142	60365	and Switch)	204	73412	Pivot Pin
143	58174	Cushion Ring	205	41723	Spring Clip
144	40804	Thrust Washer (2)	206	73447	Press Button
145	72230	Ball Race	207	73480	Lifting Lever
146	43858	Spring Clip	208	73481	Screw
147	71572	Index Roller	209	41611	Spring
148	58212	Index Bracket	210	41804	Spring
149	41848	Spring	211	41723	Spring Clip
150	58209	Support Bracket	212	73414	Index Lever Moulding
151	58210	Setting Blade	213	40627	Washer (2)
152	44708	Spring	214	40021	Screw
153	72352	Speed Cam	215	44034	Screw (2)
			216	73416	Spring Blade
			Also		
59028		Grey Phono Lead	73511		Strain Relief Lead Clip
59029		Brown Phono Lead	44126		Strain Relief Screw
58999		Line Cord Assembly	73661		Damping Pad for Mounting Spring (4)

SL 75 TOP VIEW

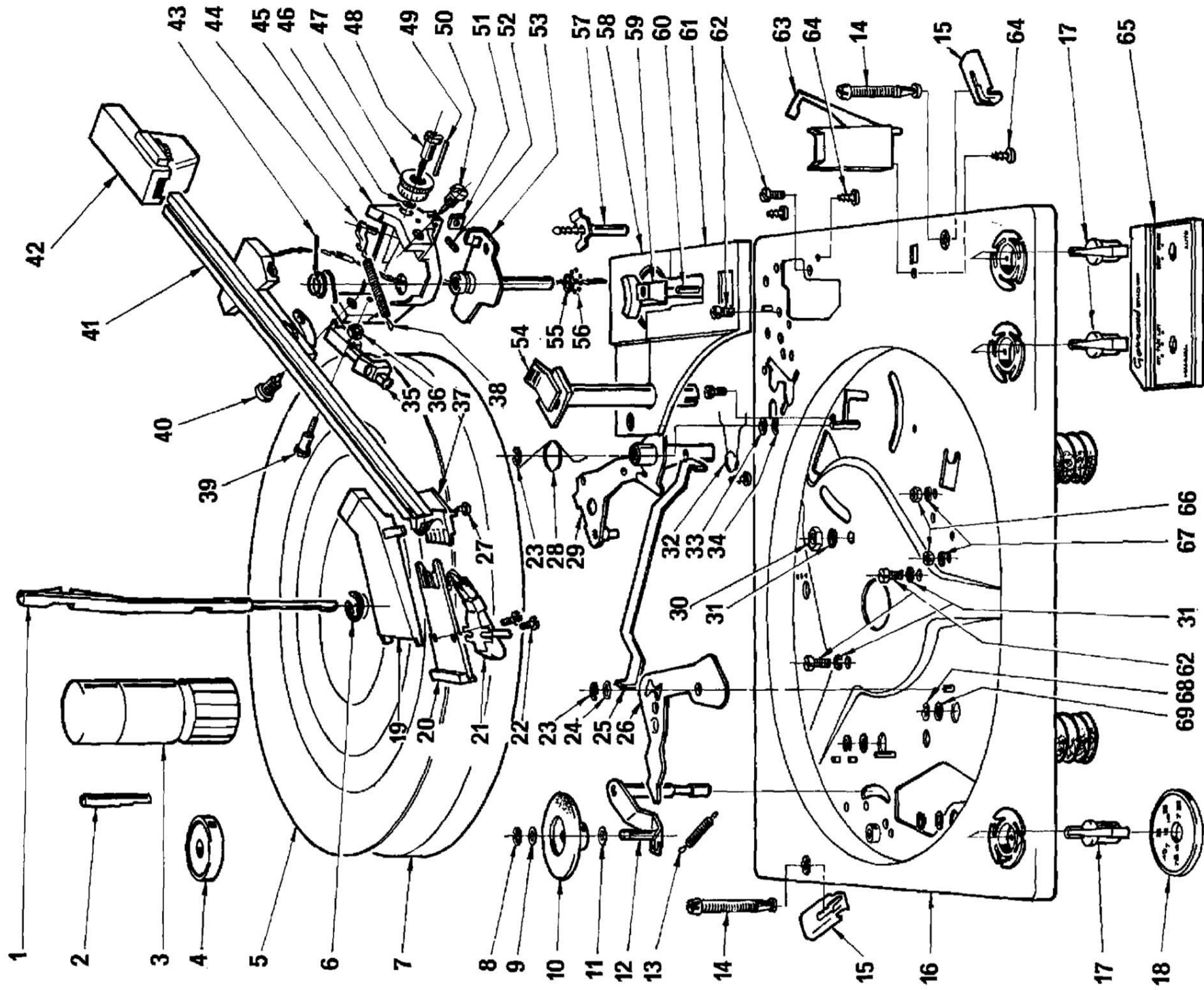

MODEL SL 75 EXPLODED VIEW PARTS ABOVE UNIT PLATE

Ref	Part No.	Description	Ref	Part No.	Description
1	72340	Automatic Record Spindle	53	72305	Pickup Spindle
2	73475	Manual Record Spindle	54	73397	Record Platform and Steady
3	LRS 20	Large Centre Hole Automatic Record Spindle	55	43279	Thrust Washer (2)
4	72698	Large Centre Hole Manual Record Spindle Adaptor	56	43204	Ball (15)
5	73308	Turntable Mat with Centre Disc	57	72479	Friction Bracket
6	43057	Spring Clip	58	73578	Pickup Base Cover (Back Section)
7	73310	Turntable, without Mat	59	72319	Lifting Platform
8	43818	Spring Clip	60	72314	Cueing Plunger
9	40985	Washer	61	73579	Pickup Base Cover (Front Section)
10	58220	Intermediate Wheel	62	40183	Screw (5)
11	40826	Washer	63	72267	Pickup Rest (1)
12	71545	Support Lever	63A	40560	Washer for Pickup Rest - not shown
13	44819	Spring	63B	44214	Screw for Pickup Rest - labelled (64)
14	44120	Transit Screw (2)	64	44126	Screw (2)
15	43855	Clip for Screw (2)	65	73372	Control Panel (1)
16	73312	Unit Plate, with Pins, etc.	66	41008	Nut (2)
17	73257	Control Knob (3)	67	42526	Spring Washer (2)
18	73255	Speed Control Panel	68	41723	Spring Clip (3)
19	72375	Head Shell	69	40695	Washer (3)
20	72390	Cartridge Mounting Plate Type C1			
21	State Type	Pickup Cartridge			
22	59048 / 045	Screws etc. Fixing cartridge			
23	41723	Spring Clip (5)			
24	40944	Washer			
25	72255	Tension Link			
26	72254	Tension Lever			
27	44177	Screw			
28	44952	Spring			
29	72256	Stop Lever			
30	41006	Nut			
31	42520	Spring Washer (3)			
32	44952	Spring			
33	40944	Washer			
34	42561	Bowed Washer			
35	73237	Bias Compensator			
36	73228	Bush			
37	72424	Pickup Leads with Connector			
38	44962	Spring			
39	44321	Screw			
40	70697	Pivot Screw			
41	72370	Pickup Arm Tube, with Wiring and Bearings			
42	73241	Counterbalance Weight			
43	44947	Spring			
44	72357	Spring Anchor			
45	73240	Pivot Bracket, with Pivot Screws			
46	42562	Washer			
47	72417	Dial			
48	44281	Screw			
49	71194	Pin			
50	70697	Pivot Screw			
51	72891	Locking Washer			
52	40240	Screw			

SL 95 PICKUP ARM

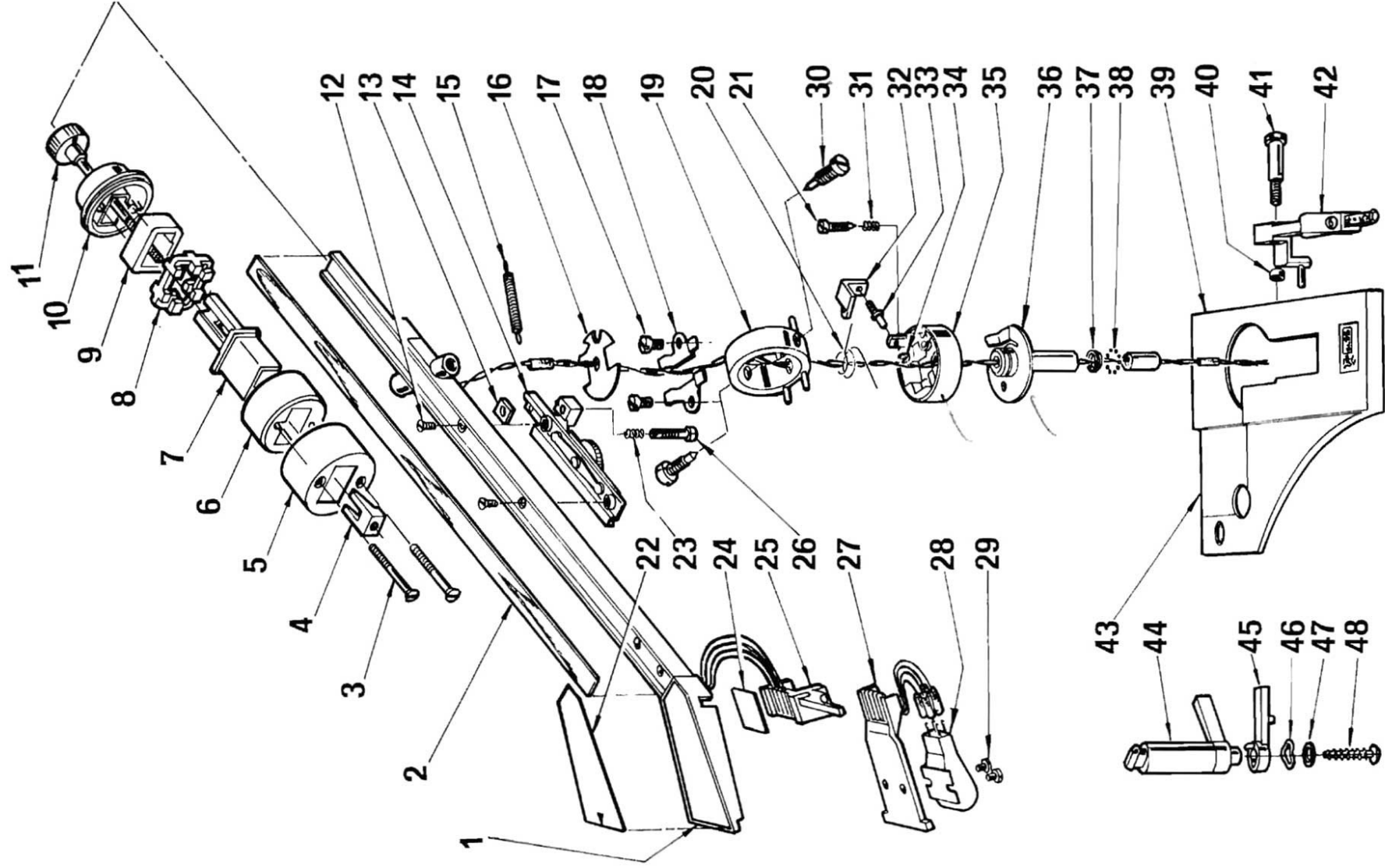

SL 95 PICKUP ARM EXPLODED VIEW

PARTS LIST

Ref	Part No.	Description	Ref	Part No.	Description
1	73324	Pickup Arm Unit	25	73325	Pickup Lead and Contact Assembly
2	73366	Wood Trim	26	44312	Pickup Height Adjustment Screw
3	44314	Fixing Screw (2)	27	73361	Cartridge Mounting Plate Type C2
4	73342	Locking Bar	28	State Type	Pickup Cartridge
5	73340	Cover	29	59048/045	Pickup Cartridge Fixing Kit
6	73338	Lead Weight	30	73434	Pivot Screw Assembly (2)
7	73335	Slide Casting	31	44963	Spring
8	73337	Rubber Mount	32	73360	Anchor
9	73368	Spacer	33	44311	Screw
10	73369	End Moulding	34	43820	Spring Clip
11	73441	Locking Screw Unit	35	73346	Gimbal Base
12	44318	Screw fixing Stylus Adjuster (2)	36	73384	Pickup Spindle Unit
13	40906	Friction Washer	37	73279	Thrust Washer
14	73331	Stylus Force Adjuster Unit	38	43204	Steel Ball (15)
15	44962	Counterbalance Spring	39	73388	Pickup Base Cover, Rear
16	73358	Decor Plate	40	40992	Washer
17	00243	Screw (2)	41	44321	Pivot Screw
18	73359	Clamp (2)	42	73390	Bias Compensator Assembly
19	73354	Gimbal Assembly (with cross pivots)	43	73387	Pickup Base Cover, Front
20	44922	Overload Spring	44	73491	Pickup Rest Body Assembly
21	44310	Pickup Lowering Position Screw	45	73428	Pickup Rest Base
22	73440	Pickup Head Cover	46	02293	Spring Washer
23	44972	Spring	47	40560	Washer
24	73439	Insulation Plate	48	44126	Screw

Maintenance and Adjustments (continued)

Cueing Height:

This adjustment controls the height which the pickup rises when the cueing lever is operated and is normally set to be $\frac{1}{16}$ " between stylus tip and the top face of one record on the turntable. When extra accuracy is required in aligning the pickup over a record the height can be reduced and when the Pause feature is to be used for a complete stack of records, the height can be increased. Turn screw in diagrams 10 and 11 counterclockwise to reduce setting and clockwise to increase.

Pickup Tracking:

To track correctly, the pickup stylus force must be that recommended for the cartridge fitted, the stylus must be clean and not worn and pickup arm movement must not be affected by any restriction such as tight pickup leads at the rear of the arm.

Pickup Muting Switch:

The muting switch is incorporated with the phono socket, diagram 4, and short circuits the pickup output when mechanism is engaged. If faulty, check that the muting switch spring contact wires are clean and make and break contact properly. If necessary, clean contact faces or adjust anchorage of spring operating switch.

To Remove and Refit Turntable:

When this is necessary, remove the record spindle, lift off the turntable mat, then spring off the wire clip retaining the turntable, using a small screwdriver and noting location for re-assembly. Place fingertips around edge of turntable, and lift clear. When replacing turntable, revolve it clockwise slowly by hand, so that it locates and runs freely. If thrust washer adheres to turntable boss see that it is replaced when refitting turntable.

Speed:

Speed variation may be caused by warped records slipping on one another. If so, play singly or put a small piece of adhesive tape on record labels to improve drive. Check that there is no lubricant on the driving surfaces of the motor pulley, intermediate wheel or turntable causing the drive to slip. Check too, that the rubber intermediate wheel height is set correctly to the appropriate motor pulley steps, without rubbing the side of the adjacent step. Adjust height if necessary, see diagrams 12 and 13.

Motor:

If speed is consistently fast or slow, check that motor pulley is suitable for frequency of power supply. Power supply details are labelled on the motor and the motor pulley is colour finished, nickel for 50 Hz and brass for 60 Hz power supply. If motor fails to start, check power supply to motor, then with power supply disconnected check motor switch and plug-in lead connections to switch and motor. See that switch blades are clean and make good contact and if a dual voltage range unit make sure links in connecting block are secure and connected as in diagram 2.

To Remove Motor Pulley:

The pulley has minimum clearance between its bore and the motor shaft, to ensure true running. If, with its fixing screws loosened, the pulley is tight on the shaft, apply gentle heat to the base of the pulley for about 30 seconds using a small, clean soldering iron, the pulley should then slide off easily. Use this method to fit a new pulley if necessary, but take care not to damage the intermediate wheel or any wiring when using a soldering iron. Also make sure pulley fixing screws are equally tight. When fitted, the pulley should be set relative to the intermediate wheel, as in diagram 12.

Intermediate Wheel Set Level
With Top of Stop Pin at
33 $\frac{1}{2}$ Speed Setting

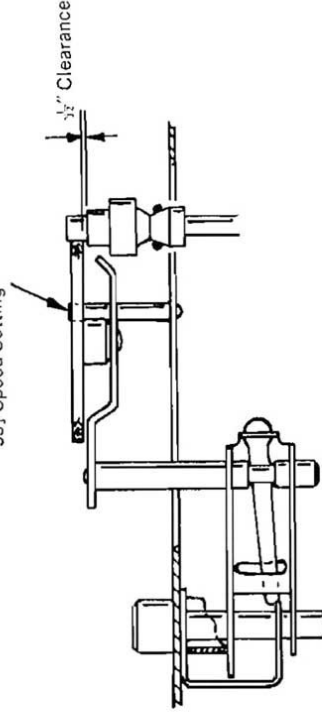

Diagram 12

Rubber Intermediate Wheel Height:

The position of the intermediate wheel may be adjusted, using the blue spring steel blade, shown in diagram 13; the wheel should be set to the pulley step appropriate to the speed control setting, with clearance as shown in diagram 12.

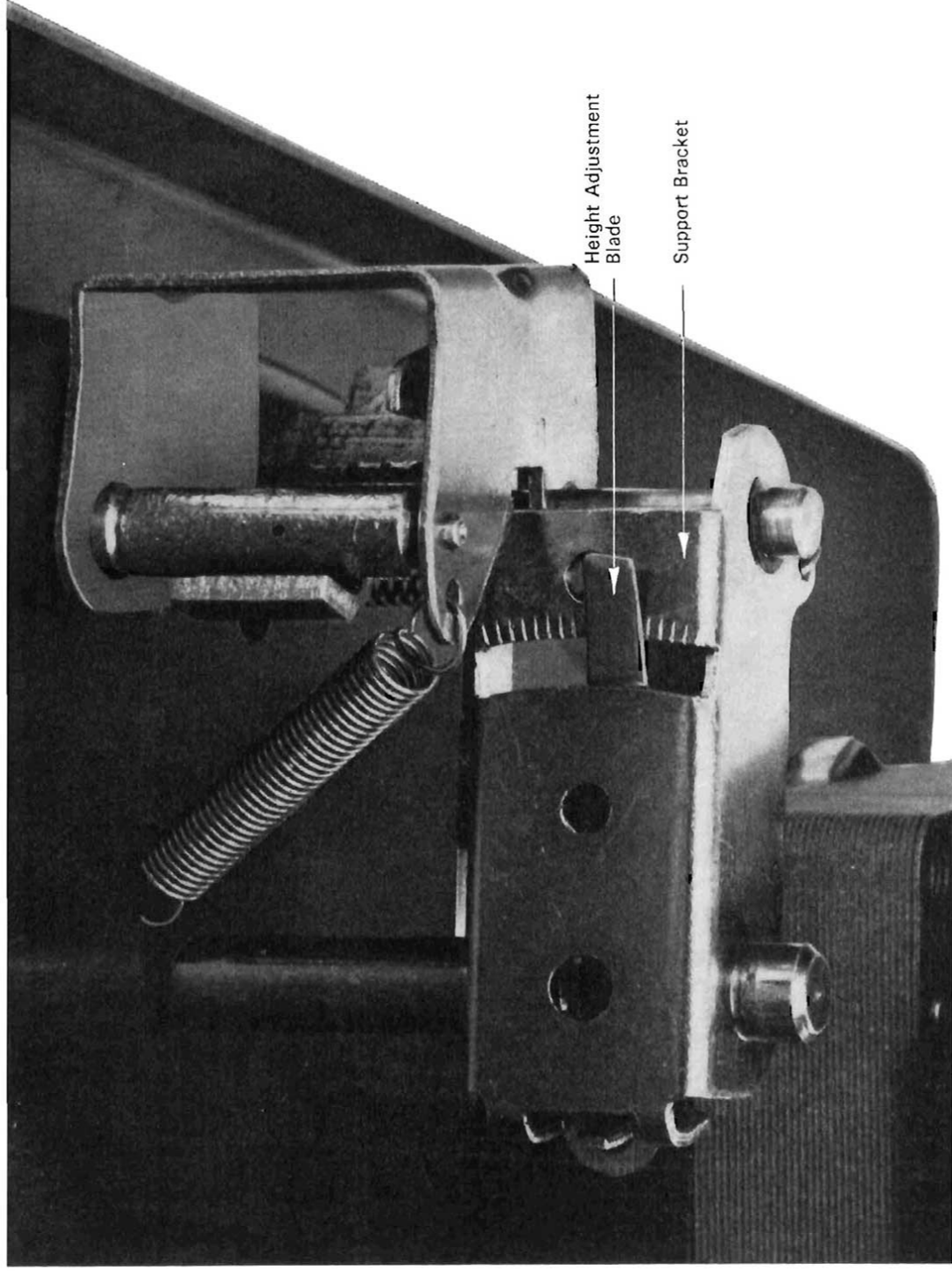

Diagram 13

Lubrication

(Numbers in brackets refer to S.L. 75 exploded views)

Thin, high grade machine oil such as that used on sewing machines and grease similar to, or lighter than, petroleum jelly should be used. The bearings in the motor, turntable and intermediate wheel are of the oil-retaining type and rarely need lubricating. When the need for oil is apparent these bearings should be lubricated very sparingly.

It is essential that the motor pulley, rubber intermediate wheel and the inside rim of the turntable be kept completely free from oil or grease to prevent slipping. After lubrication, remove all traces of surplus lubricant from these driving surfaces with clean, dry cloth before running the unit.

The main lubrication points are shown on Diagram 14 but additional points which may require attention at more extended intervals are as listed. Numbers in brackets identify associated parts on the exploded views.

Apply a smear of light grease to the following parts:

1. Pickup Base

- a) Pickup Cam (121), on working surfaces and main bearing surface.
- b) Cueing Cam (111), on lifting cam face and slot for cueing link (109).
- c) Switch off Lever (rivetted pivot), on face contacting stop lever (29) and edge contacting tail of pickup level (127).
- d) Retracting Lever (117), on edge contacting the pin on friction lever (120). The radial slot in the friction lever must be kept free from lubricant.

2. General

- a) Main Cam (191), on surfaces of ribs on top of cam.
- b) Switch Lever (105), on working surfaces.

- c) Stop Link (104), in slot and hole.
- d) Catch Lever (106), on working surfaces.
- e) Trip Lever (173), on the edge contacting the pin on trip operating lever (171).
- f) Release Lever (139), on surface sliding against cam lever (138), in slots and on edges guided by lugs on turntable spindle housing casting (141).
- g) Auto Control Lever (100), in hole and on working edge.
- h) Manual Control Lever (100), in slot for cueing link (109).
- i) Selector Cam (155), on working edges.
- j) Speed Lever (154), in slot.
- k) Speed Cam (153), on both sides.
- l) Unit Plate (16), in V-shaped slot at right hand side of turntable well and on the area under the plate around this slot.

- m) Stop Lever (29), on edges contacting the pin on trip operating lever (171).
- n) Trip Operating Lever (171), in slots and between lever and retaining washer (172).

Apply light oil sparingly to the following parts:

I. General

- a) Turntable spindle and Pickup Arm, on ball bearings (145 and 56).
- b) All pivot pins, spindles and rollers except the pivot of the cueing cam (111) which is lubricated during assembly with Garrard Damping Fluid, and the trip rod (131) or any part moved by it which must be kept clean and dry.
- c) Main Cam (191), on tracks on underside.
- d) Record Support Platform (54), a thin smear on the pillar.
- e) Press Button (206), on the surface sliding inside the platform base casting (200).

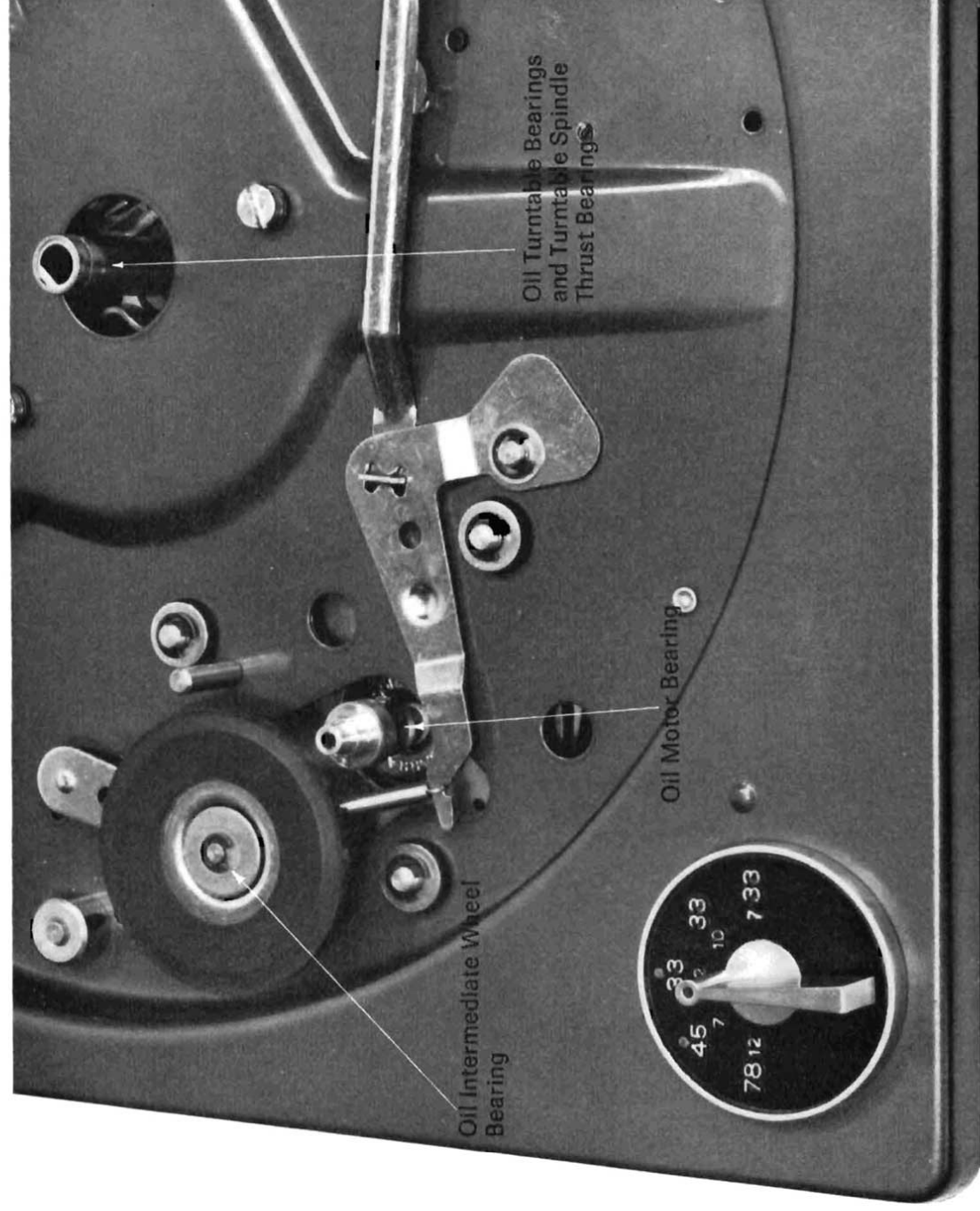
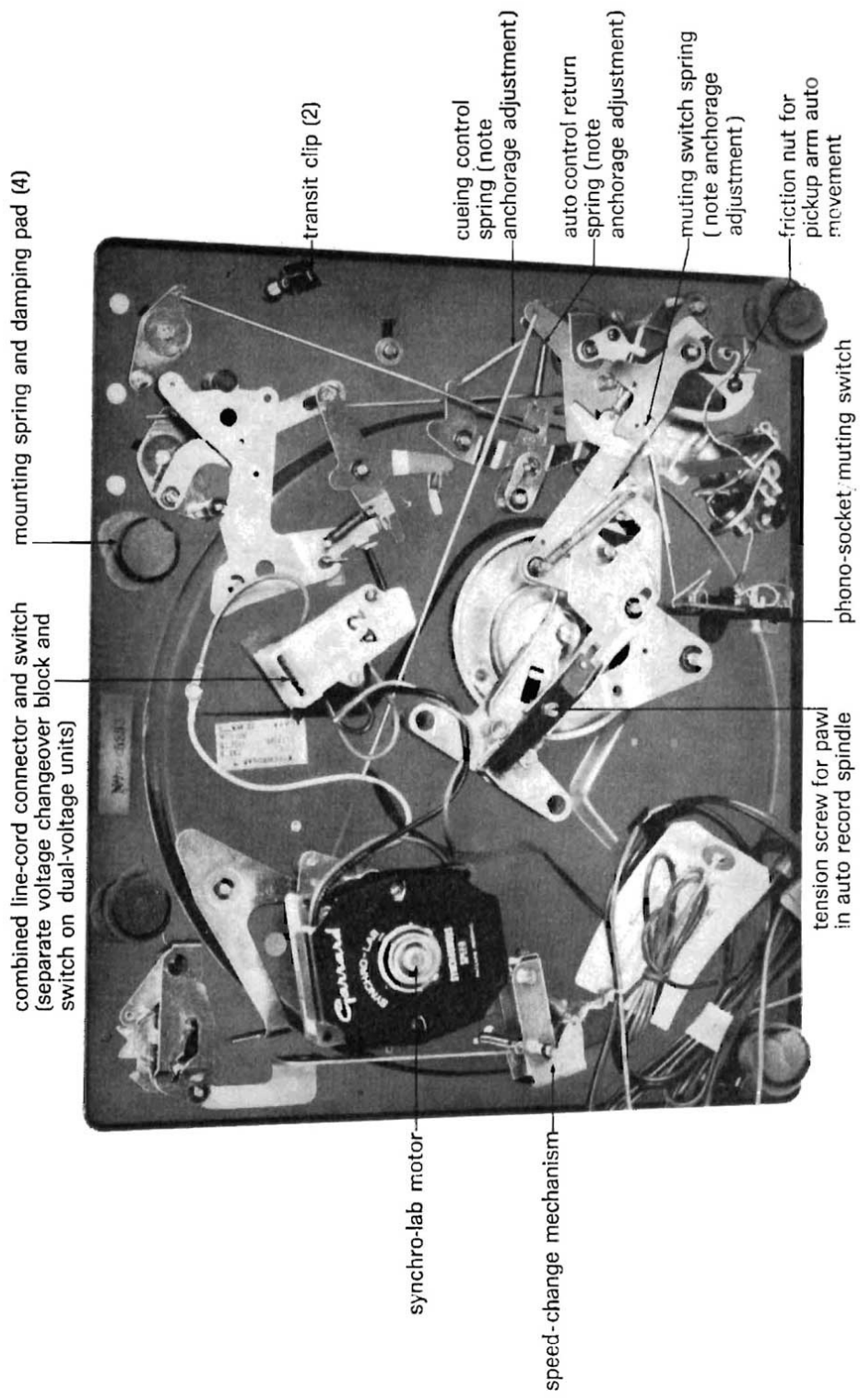

Diagram 14



Underside view SL 75-SL 95

FAULT CHART

THE UNIT SHOULD BE DISCONNECTED FROM ITS POWER SUPPLY AND THE STYLUS PROTECTED BEFORE MAKING SERVICE ADJUSTMENTS.
NUMBERS IN BRACKETS REFER TO PARTS SHOWN ON THE SL 75 EXPLODED VIEW.

FAULT	CAUSE	CORRECTION
TURNTABLE SPEED Turntable fails to start, or runs slowly when switched on.	<ol style="list-style-type: none"> 1. Oil or dirt on driving surfaces 2. Faulty intermediate wheel spring (13) 3. Intermediate wheel support lever (12) not free 4. No power supply 5. Faulty motor coil(s) 6. Bearings of motor out of line 7. Motor pulley (168) or intermediate wheel (10) height set incorrectly 8. Bearings not free 	<ol style="list-style-type: none"> 1. Take off spring clip (6), remove turntable (7) and clean inside rim, intermediate wheel (10) and motor pulley (168). 2. Check that spring is secured. Move manual control to PLAY - spring should extend. If it does not, replace it. 3. Wheel (10) should engage motor pulley (168) firmly when switched on and retract when switched off. If not, lubricate spindles; if damaged replace. 4. Remove plugs (142) from motor (178), switch on, and check with voltmeter. If no power, check back to source outlet, looking for loose connections, faulty switch contacts, etc. 5. Remove plugs from motor (178) to check continuity of each coil with ohm meter. Replace motor if necessary. 6. If rotor shaft is tight, tap the motor body with a small block of wood (e.g. screwdriver handle) to realign bearings. Use only thin machine oil on these bearings. 7. See 'Adjustments'. Check that both motor pulley screws are tight. 8. Check motor, intermediate wheel and turntable bearings for free running. Clean and lightly oil, if necessary - see 'Lubrication'.
Record speed varies (Wow and Flutter.)	<ol style="list-style-type: none"> 1. Various 2. Warped records in stack causing slipping 3. Damaged rotor shaft 4. Flats on driving surface of intermediate wheel (10) 	<ol style="list-style-type: none"> 1. See 'Turntable Speed', above, Causes and Corrections 1, 7 and 8. 2. It is not advisable to play badly warped or 'Dished' records automatically, although small strips of adhesive paper on their labels may help adjacent records to key together. 3. Replace motor (178). 4. If running unit for a while does not cure the fault, replace the wheel.

FAULT	CAUSE	CORRECTION
-------	-------	------------

RECORD DROPPING

Records fail to drop.

- | | | |
|----|---|--|
| 1. | Damaged record spindle (1) | 1. Remove spindle and check that its record pushing pawl moves freely. If not, replace spindle. |
| 2. | Moulding flash or label paper in centre hole of new record | 2. Remove carefully with a pen-knife. |
| 3. | Non-standard records | 3. Records with over-sized centre holes or more than 0.090" thick at centre hole may fail to drop. Play them manually. |
| 4. | Insufficient tension in leaf spring supporting pawl of record spindle (1) | 4. Tighten screw (140) to apply light pressure. |
| 5. | Record Spindle (1) not seated properly | 5. Press it down until a light click is felt as spring clip (6) holds it in position. |

Two or more records drop together.

- | | | |
|----|------------------------|--|
| 1. | Damaged record spindle | 1. Check that both latches at the top of the spindle (1) fall freely. Do not oil them. Replace spindle, if faulty. |
| 2. | Non-standard records | 2. Records less than 0.053" thick at centre holes. Play them singly. |

PICKUP ARM MOVEMENT

Pickup tracks incorrectly.

- | | | |
|----|---|---|
| 1. | Stylus force too low | 1. Check that force is not lower than cartridge manufacturer's recommended figure. Adjust if necessary - see 'Adjustments'. |
| 2. | Dust accumulated around stylus tip | 2. Clean carefully. |
| 3. | Pickup leads tight or trapped at rear of arm | 3. Make sure leads are slack and check that they are not caught in mechanism below unit plate. |
| 4. | Worn or wrong side stylus tip radius | 4. Replace stylus. |
| 5. | Groove guard on record (Raised rim) | 5. If stylus lands too far out it may slide down the slope of the raised rim and jump the first playing grooves. Set lowering position so that stylus lands well inside the raised rim - see 'Adjustments'. |
| 6. | Automatic trip links (127, 131, 192 and 190) not free | 6. Move pickup inwards by hand checking for damaged or tight linkage. Reshape or replace, as necessary. |
| 7. | Damaged pickup spindle bearing (53, 55 and 56) | 7. Replace, as necessary. |
| 8. | Body of cartridge (21) touches record | 8. Make sure fixing screws (22) are tight, pack up end of cartridge bracket with thin card or reshape bracket (21) if metal. |

FAULT	CAUSE	CORRECTION
Pickup lands on record too far out or in.	<ol style="list-style-type: none"> 1. Lowering position incorrectly set 2. Tails of pickup lever (127) not square 	<ol style="list-style-type: none"> 1. See 'Adjustments'. 2. Reshape or replace.
Pickup arm fails to lower.	<ol style="list-style-type: none"> 1. Spring (108) controlling cueing cam (111) disengaged 2. Lifting spindle (59) not free 3. Pickup arm pivots (40) and (50) not free 4. Pickup rest safety catch (63) not released 	<ol style="list-style-type: none"> 1. Anchor spring (108) to cueing cam and trip lever (173), being careful not to over stretch it. 2. With pickup arm raised, lift platform moulding at top of spindle. It should spring back. If not, check for damage or restriction. Clean and oil if necessary. 3. Clean or replace part(s). 4. Turn it outwards.
Pickup begins to lower, then swings in.	<ol style="list-style-type: none"> 1. Pickup leads tight or trapped 	<ol style="list-style-type: none"> 1. Make sure the leads are slack, and see that they are not caught up in mechanism below unit plate.
Pickup fails to lift when Auto control is moved to 'START' or to return at end of record.	<ol style="list-style-type: none"> 1. Damaged trip pawl (190) 2. Auto Trip Link (131) Bent 	<ol style="list-style-type: none"> 1. Reshape vertical lug or replace pawl. 2. Reshape or replace it.
Pickup lands on record and immediately rejects, next record drops and fault repeats until normal switch off at end of stack.	<ol style="list-style-type: none"> 1. Spring (110) disengaged 2. Auto control lever (101) tight 	<ol style="list-style-type: none"> 1. Anchor spring (110) to hole in trip operating lever (171) and to switch off return lever (113). 2. Check operation of return spring (110) and grease sliding surfaces of trip operating lever (171) and unit plate.
NOISE Rumble, heard through speaker(s) while stylus is in blank record groove.	<ol style="list-style-type: none"> 1. Lack of lubrication 2. Intermediate wheel (10) rubbing against side of motor pulley step (168) or dirt on running surface 3. Driving surface of intermediate wheel (10) dirty, indented or hardened 4. Faulty installation 5. Worn turntable spindle bearings 6. Dirty turntable thrust bearings (144) and (145) or cushion ring (143) 	<ol style="list-style-type: none"> 1. See 'Maintenance'. 2. Check heights of wheel and pulley - see 'Adjustments'. 3. If running the unit for a while and cleaning the surface of the wheel does not help, replace it. 4. Check that unit floats freely on its mounting springs, that the motor hangs freely in its rubber grommets and that no part of the mechanism is in contact with the mounting board. 5. Replace thrust washers (144) ball race (145) and/or cushion ring (143) as necessary. 6. Clean and oil bearings. Replace cushion ring if hard.

FAULT	CAUSE	CORRECTION
Interference, heard as crackles etc. through speaker(s)	<p data-bbox="280 898 392 1177">1. Faulty contact in power supply circuit, pickup circuit or earth connection</p> <p data-bbox="448 898 515 1177">2. Muting switch (134) not operating</p>	<p data-bbox="219 43 280 898">N.B. DISCONNECT POWER BEFORE OPENING SWITCH</p> <p data-bbox="280 43 425 898">1. Examine all leads and connections for damage and check screws for tightness. Remove screws (162) holding motor switch, take off cover and check for good contact between blades. Clean and form blades as necessary.</p> <p data-bbox="448 43 515 898">2. Check that spring (133) is anchored at both ends.</p>
<p data-bbox="548 1177 582 1543">AUTOMATIC SWITCH</p> <p data-bbox="582 1177 660 1543">Fails to switch off when last record has played or switches off without playing.</p>	<p data-bbox="582 898 660 1177">1. Auto control lever (101) tight</p>	<p data-bbox="582 43 660 898">1. Check operation of return spring (110) and grease sliding surfaces of trip operating lever (171) and unit plate.</p>
<p data-bbox="705 1177 739 1543">RECORD SUPPORT PLATFORM</p> <p data-bbox="739 1177 851 1543">Platform fails to rise and lock into position when button (206) is pressed.</p>	<p data-bbox="739 898 817 1177">1. Return spring (203) damaged or disengaged</p> <p data-bbox="840 898 884 1177">2. Need for lubrication</p> <p data-bbox="907 898 974 1177">3. Button not pressed down far enough</p> <p data-bbox="996 898 1052 1177">4. Locating pin (208) damaged</p>	<p data-bbox="739 43 817 898">1. Replace or re-anchor spring to hole in lever (207) and projection on casting (200).</p> <p data-bbox="840 43 884 898">2. See 'Lubrication'.</p> <p data-bbox="907 43 974 898">3. Press button down until the top is level with top of cover moulding (61).</p> <p data-bbox="996 43 1052 898">4. This pin should be held in a V-slot in casting (200) if it is bent, unscrew and replace it.</p>
Platform fails to stay down when pressed.	<p data-bbox="1086 898 1176 1177">1. Index lever moulding (212) damaged or fixing screws (215) loose</p> <p data-bbox="1198 898 1321 1177">2. Centre of Platform not pressed down far enough for locking device to engage</p>	<p data-bbox="1086 43 1153 898">1. Replace moulding or re-tighten screws.</p> <p data-bbox="1198 43 1321 898">2. Press down until stopped by cover moulding (61).</p>

When ordering spares, please quote model SL 75 or SL 95 code (from inspection label), part number and colour, voltage and frequency when applicable. Also reference number stamped on underside of unit plate.

Service and Spares Enquiries in U.S.A.:
Garrard Sales Corporation,
Westbury,
New York 11590.

In other territories:—

Garrard Engineering Limited
Service and Spares Department,
Newcastle Street,
Swindon,
Wiltshire,
England.

(Telephone: SWINDON 5381)

