

**INSTRUCTION MANUAL**

**GOLDRING**

**'88'**

**TRANSCRIPTION UNIT**

**GOLDRING MANUFACTURING CO. (G.B.) LTD.**

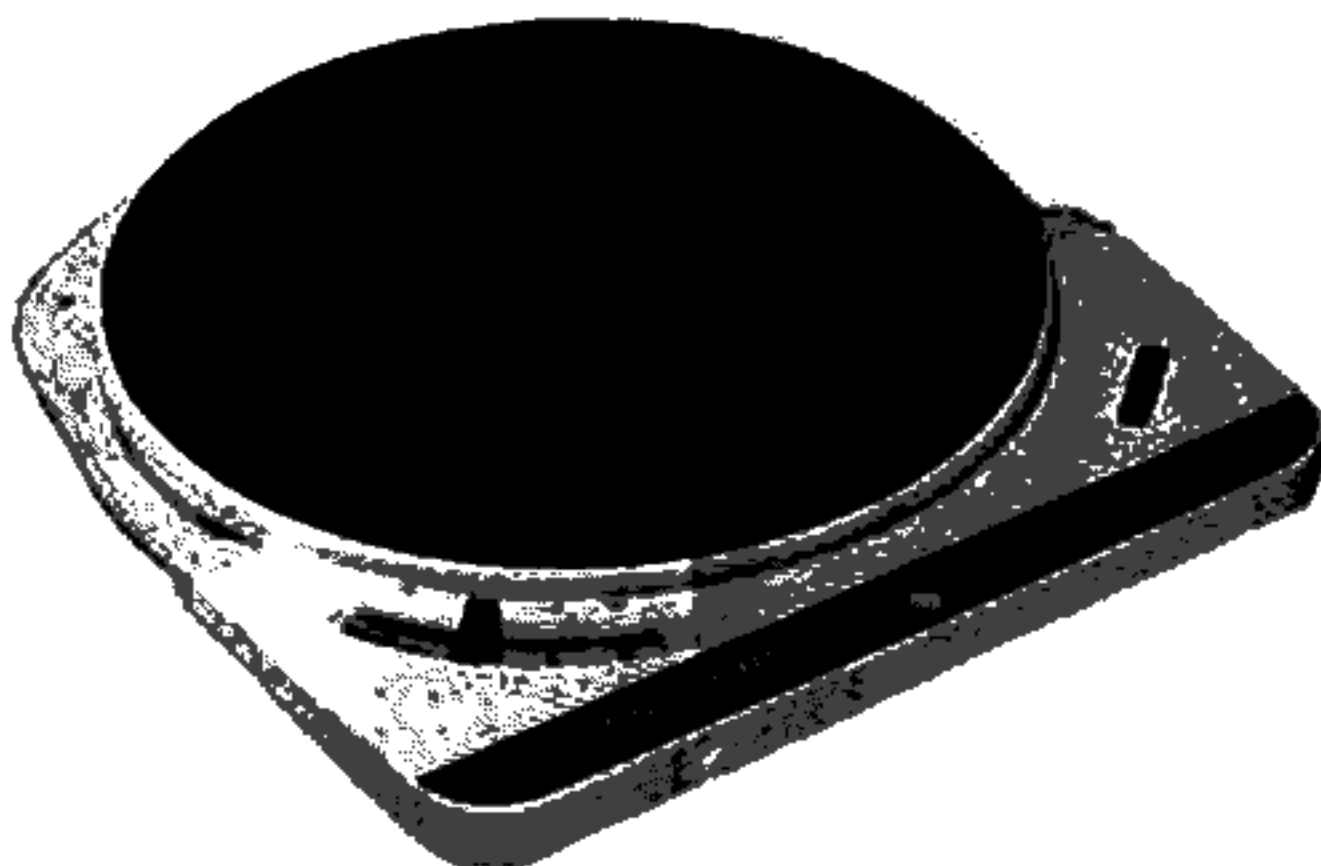

## **INSTRUCTION MANUAL FOR GOLDRING '88' TRANSCRIPTION UNIT**

### **DESCRIPTION**

This new Goldring-Lenco Transcription Unit has been developed particularly for those high-fidelity enthusiasts who require a unit of high transcription quality but wish to use a transcription arm of their own choice. It offers complete freedom in mounting arrangements.

The '88' is styled in the modern idiom and beautifully finished in white enamel. It has all the highly successful mechanical features of other Goldring-Lenco transcription units—some of which are still unique. The steel

centre spindle runs in a sintered bronze bush, with a special thrust pad. The 4-pole constant velocity motor limits changes in turntable speed to less than 1% for up to 13% change in line voltage. Rumble and hum are negligible. Maximum wow and flutter is 0.2%. The 8 lb. die-cast anti-magnetic turntable is fitted with a radially-ribbed rubber mat, facilitating cleaning.

A new feature is the push button "on/off" switch, which also engages and disengages the drive. A neon pilot light gives the '88' an added refinement. The switch circuit is entirely click-suppressed.

The vertical idler in the '88' transmits positive drive from the conical shaft and gives continuously variable speed control—from less than 30 r.p.m. to above 80 r.p.m., and in the 15 to 18 r.p.m. range. All four standard playing speeds are located at pre-set click-in positions, which may be adjusted for complete accuracy with the aid of the stroboscopic disc supplied.

The GOLDRING-LENCO '88' is designed to be used with any pick-up arm.

#### SPECIFICATION

A.C. Mains 200-250 V., 50 c.p.s. 4-pole constant velocity motor (15 watts).

Continuously variable speed control.

Pre-set click-in position (adjustable) on the four standard speeds.

Centre spindle is of lapped, hardened steel in sintered bronze main bearing.

Wow and flutter—maximum 0.2%.

Rumble and hum—negligible.  
Turntable speed—less than 1% variation for 13% mains voltage change.

Fully positive drive and accurate control through precision conical shaft and vertical idler.

**DIMENSIONS:** 13" x 14".

Turntable diameter: 12".

Clearance required above motor board dependent on pickup arm fitted.

Clearance required below top of motor board: 2".

#### INSTALLATION AND OPERATION

**1 UNPACKING.** This unit was carefully checked before leaving the factory. Observe the conditions of the packing carton for signs of improper handling in transit. If damage is apparent make an immediate claim to the dealer from whom you made the purchase. Check that all items shown in paragraph 3 are complete.

**2 BASEBOARD.** The unit should be mounted on a wooden baseboard 4" to 2" thick and large enough to accommodate the unit and a separate pick-up arm. The board should be cut to provide one large cut-out and drilled for three holes of 1/2" diameter.

The position of the cut-out and the holes may be obtained by either of these two methods:—

(a) Cover the baseboard with carbon paper laid face downwards and fix the template in the desired position with drawing pins; then scribe on the heavy outline of the cut-out, so that the line is reproduced on the baseboard by the carbon paper.

(b) Attach template to the baseboard with self-adhesive tape or with pins; and prick through the template with a sharp pointed instrument such as a scriber or bradawl.

**3 CONTENTS OF CARTON.** The following items are contained in the carton:

- (a) The turntable packed in cardboard sleeve.
- (b) Rubber turntable mat.
- (c) The motor unit complete with mounting plate.
- (d) Fixing screws.
- (e) Stroboscope.

FIG. 1.

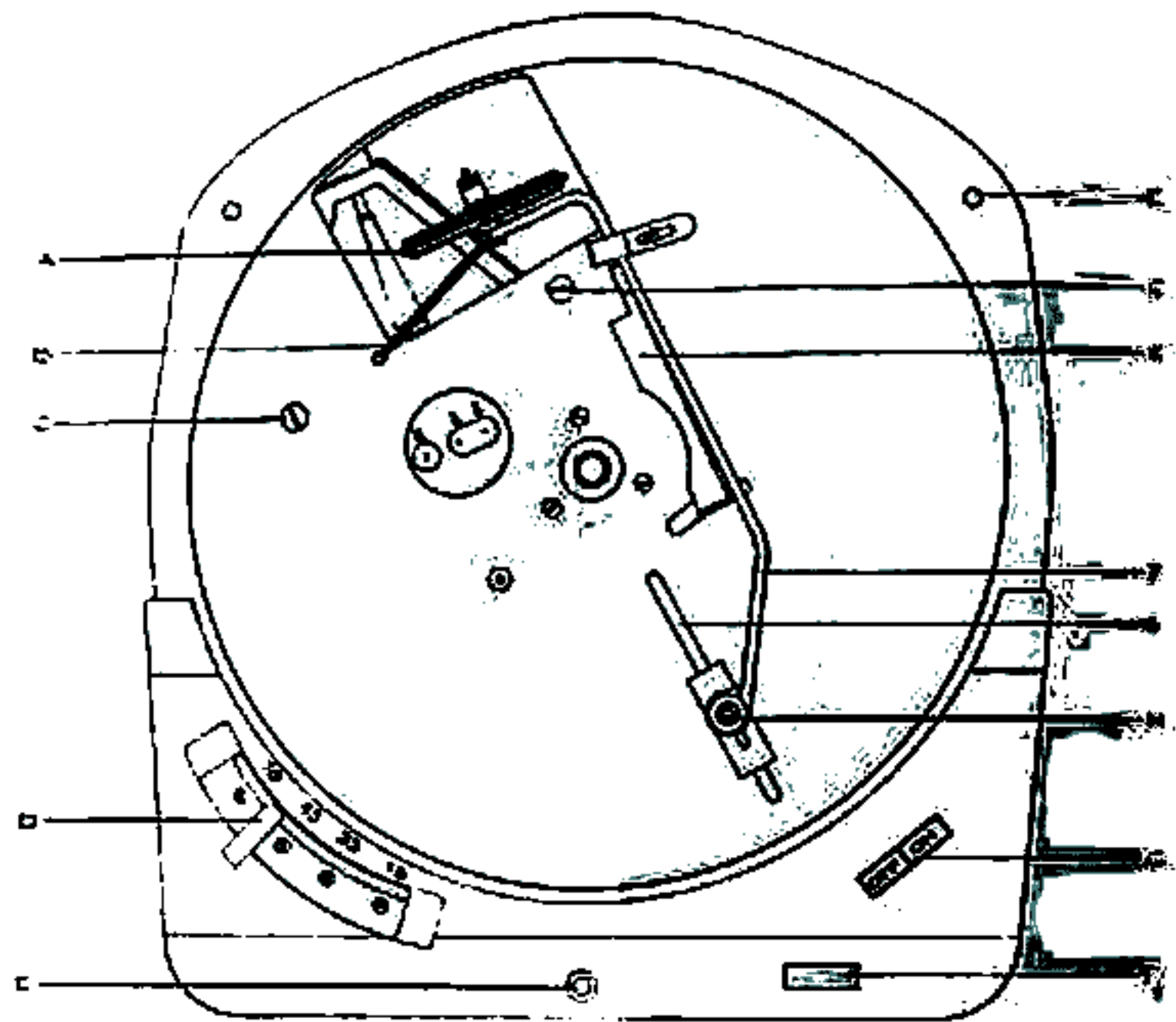

TRUE PLAN.

- WHEEL \_\_\_\_\_ A
- WHEEL SPRING \_\_\_\_\_ B
- TRANSIT SCREWS \_\_\_\_\_ C
- SPEED CHANGE \_\_\_\_\_ D
- FIXING HOLES \_\_\_\_\_ E
- NEON \_\_\_\_\_ F
- ON-OFF SWITCH \_\_\_\_\_ G
- WHEEL ARM CLIP \_\_\_\_\_ H
- SLIDE WAY \_\_\_\_\_ I
- WHEEL ARM \_\_\_\_\_ J
- DISENGAGEMENT ARM \_\_\_\_\_ K

FIG. 2

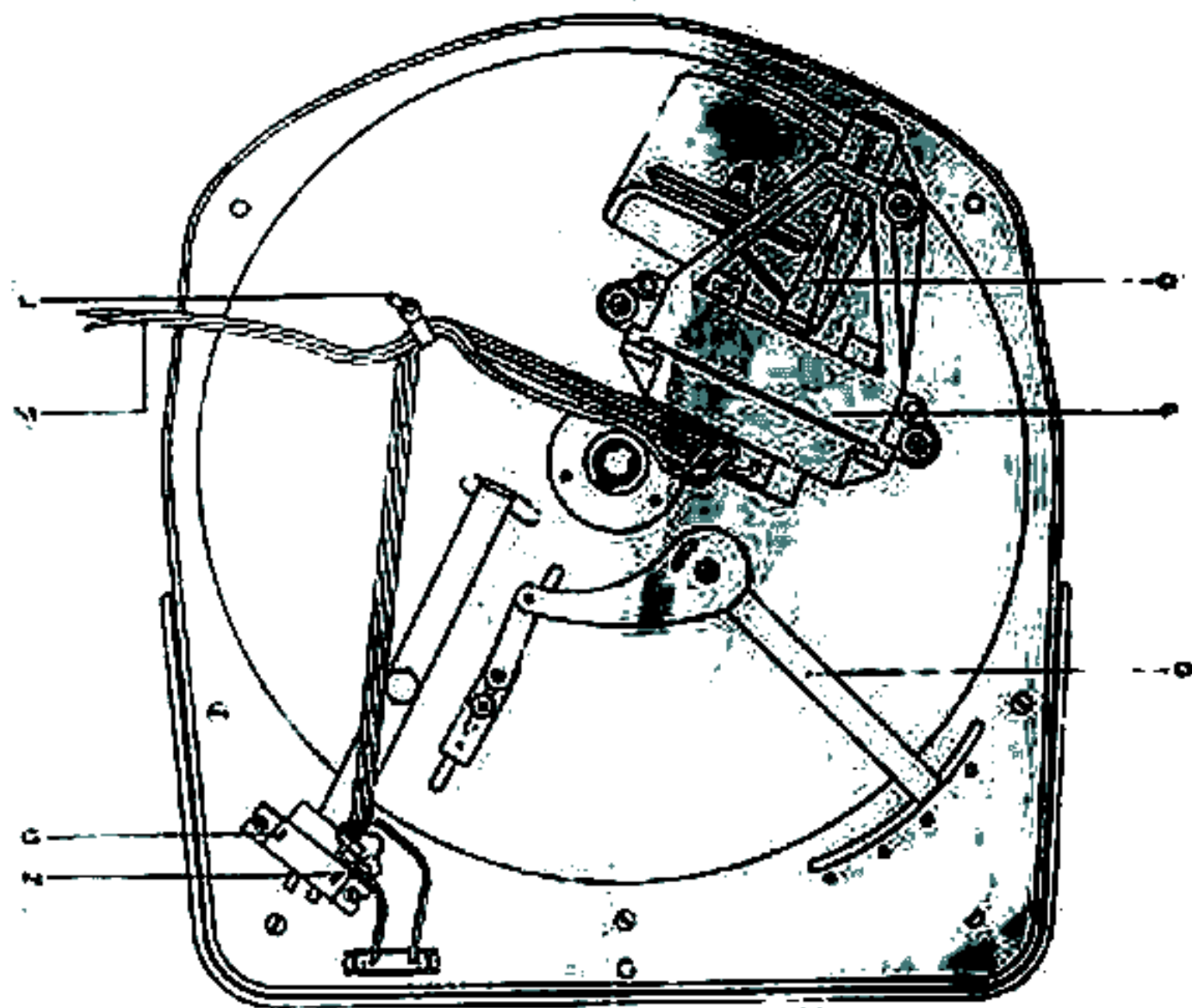

UNDERSIDE PLAN.

- EARTH TAG \_\_\_\_\_ L
- MAIN LEAD \_\_\_\_\_ M
- SWITCH \_\_\_\_\_ N
- CONDENSER \_\_\_\_\_ O
- SPEED CHANGE LINKAGE \_\_\_\_\_ P
- MOTOR ASSEMBLY \_\_\_\_\_ Q
- MOTOR CONE \_\_\_\_\_ R

FIG. 3.

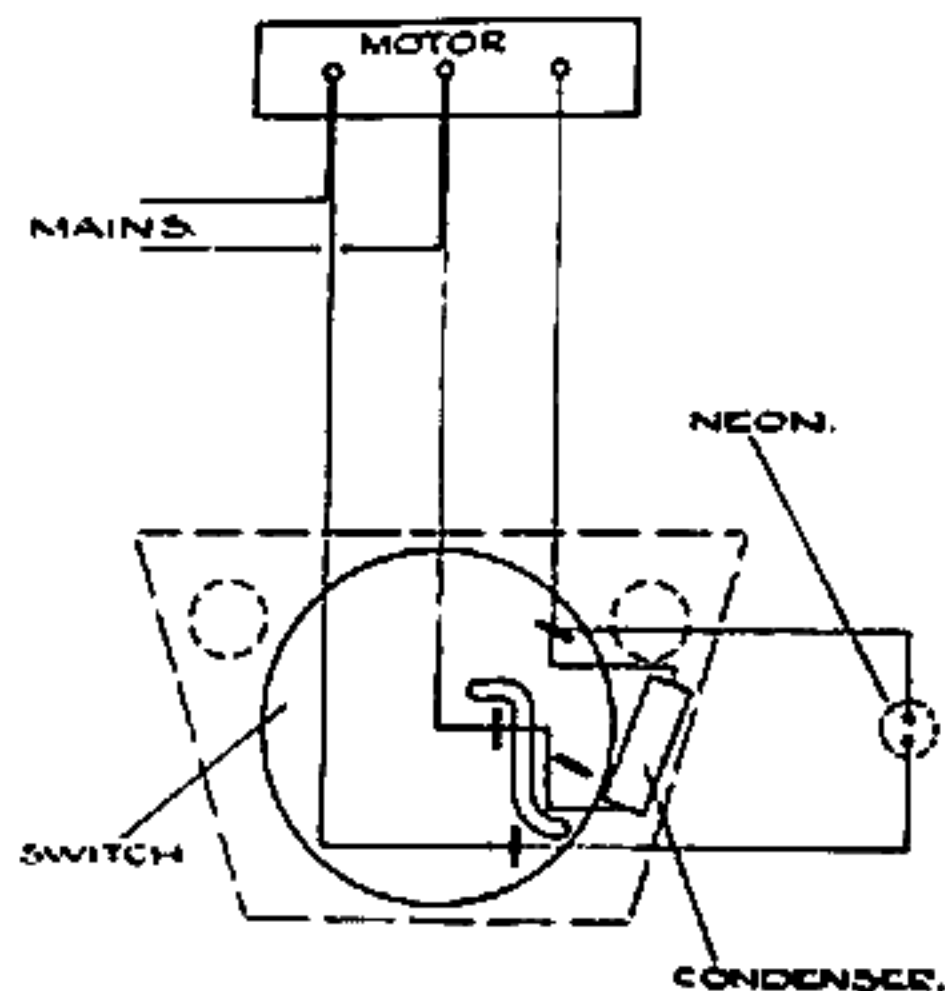

Wiring Diagram

**4 MOUNTING PROCEDURE.** The unit should be screwed down to the wooden baseboard by means of the wood screws provided. Fixing holes are shown in fig. 1(E) and coincide with the drilled holes in the baseboard. Having screwed the baseplate into position remove the two red transit screws, fig. 1(C), which hold the motor, fig. 2(P), against the baseplate.

**5 TURNTABLE.** Place the turntable over the centre spindle ensuring that it is properly seated. Place loose rubber mat over centre spindle.

In order to remove the turntable apply a sharp tap with a wooden block to the centre spindle while lifting the turntable.

**6 MAINS SUPPLY.** The unit is normally supplied for 200-250 volts 50 cycles A/C mains. Connect the mains lead fig. 2 (M) to your supply, ensuring that before this is done the unit is in the "off" position. An earth lag fig. 2(L) is fitted to the baseplate and it is recommended that a separate lead be taken from this lag to either an earth point on the amplifier or to an external earth point.

The unit is now ready for playing.

**7 TO PLAY.** Press the button, fig. 1(G), marked "ON". This will switch the motor on and illuminate the neon light, fig. 1(F). At the same time it will engage the idler wheel, fig. 1(A). Allow a few minutes for the motor to warm up before playing your records.

**8 SPEED ADJUSTMENTS.** Although every care has been taken to ensure the speed locations are pre-set accurately, it is possible that due to transit, or in mounting, these have become slightly altered. Check each speed with the stroboscope which is supplied with the unit, and should adjustment be necessary this may be done by loosening the set-screw at the side of each speed catch, and adjusting the variable speed, bar fig. 1(D), until the lines for the required speed on the stroboscope appear to remain stationary. The set-screw should then be tightened. Repeat this test at each speed.

**N.B.** The stroboscope must be used under an electric lamp operating on A/C mains. The lines on the stroboscope will never appear to be stationary if used in natural daylight or illuminated by a D/C torch light.

**IMPORTANT.** Always switch off the motor before switching off the mains supply.

## **9 MAINTENANCE & SERVICE**

The motor bearings and turntable spindle bearings are self-lubricating and no further lubrication should be necessary. Should the slide way, fig. 1(L), of the speed change mechanism run dry then a small amount of vaseline should be applied. Care must always be taken that the underside of the turntable and the idler wheel be kept clean and free from oil.

IF the turntable does not rotate but the motor is going then the idler wheel spring, fig. 1(B), needs replacing.

IF the motor does not operate but the neon light is on then the motor has developed a fault and should be repaired.

IF the neon light does not come on when the unit is switched on, the wiring should be checked, fig. 3.

IF the motor does not turn off when the unit is switched off then the switch click suppressing condenser is faulty and should be replaced, fig. 2(N).

IF speed is erratic or a rumble develops then the idler wheel should be cleaned with carbon tetrochloride as should the underside of the turntable and the motor cone, fig. 2(Q).