

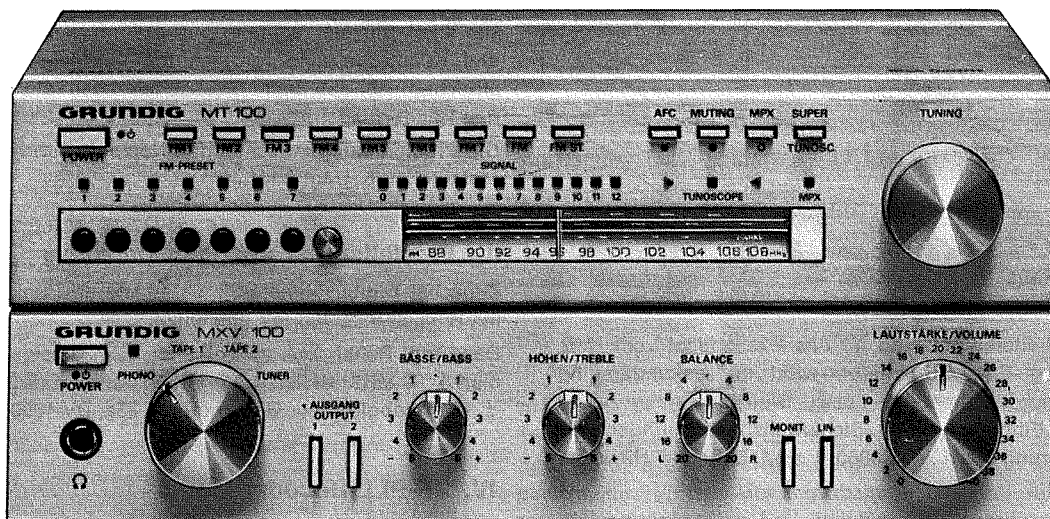

2/80

MT 100 / GB / U
MXV 100 / GB / U



Abgleich- und Prüfvorschrift

- | | |
|---|------------------------------------|
| I. Chassis-Ausbau | X. Überprüfung Frequenzgang |
| II. Allgemeine Hinweise | XI. Überprüfung Tunoscope |
| III. Einstellen der Abstimmspg. | XII. Überprüfung Muting |
| IV. ZF-PLL-Decoder-Steck-Modul | XIII. Super-Tunoscope |
| V. FM-ZF-HF-Abgleich | XIV. Überprüfung der AFC |
| VI. 19 kHz-Stereo-Tiefpaß | XV. Überprüfung FM-ST |
| VII. Messen des FM-Klirrfaktors | XVI. Prüfung der Stummschaltung |
| VIII. Messen des FM-Fremdspannungsabstandes: Mono | XVII. Einschaltverzögerung TCA 530 |
| IX. UKW-Begrenzung (-1-db-Wert) | |

Anderungen vorbehalten
ALTERATIONS RESERVED
MODIFICATIONS RESERVEES
CON RISERVA DI MODIFICA

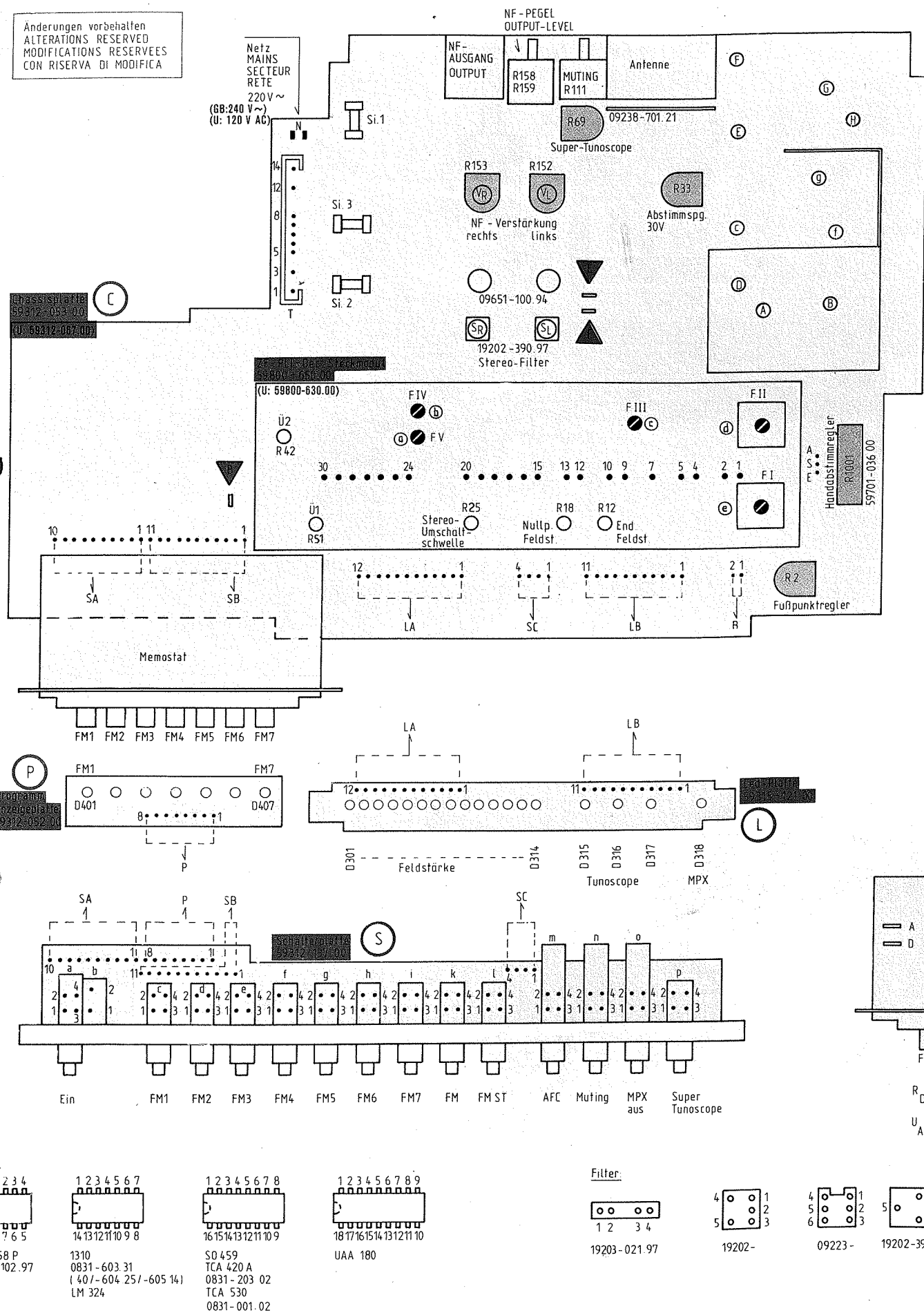

- ELKO
 - Styroflex Kondensator
 - Folien Kondensator
 - Keramik Kondensator
 - 0309 DIN
 - 0207 DIN
 - 0207 DIN Rauscharm
 - Metalloxydschichtwiderstand
 - 0204 DIN
 - schwer entflammbar
- Transistoren
- BF 245
 - BF 324, 414 RC 413, 415 BC 548, 558
 - BF 240, 241 BF 440 (BF 450)
 - 9D 135 GD 679 09654-480 97

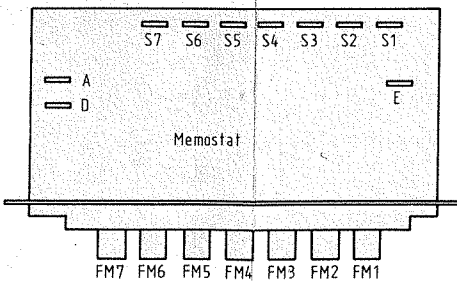
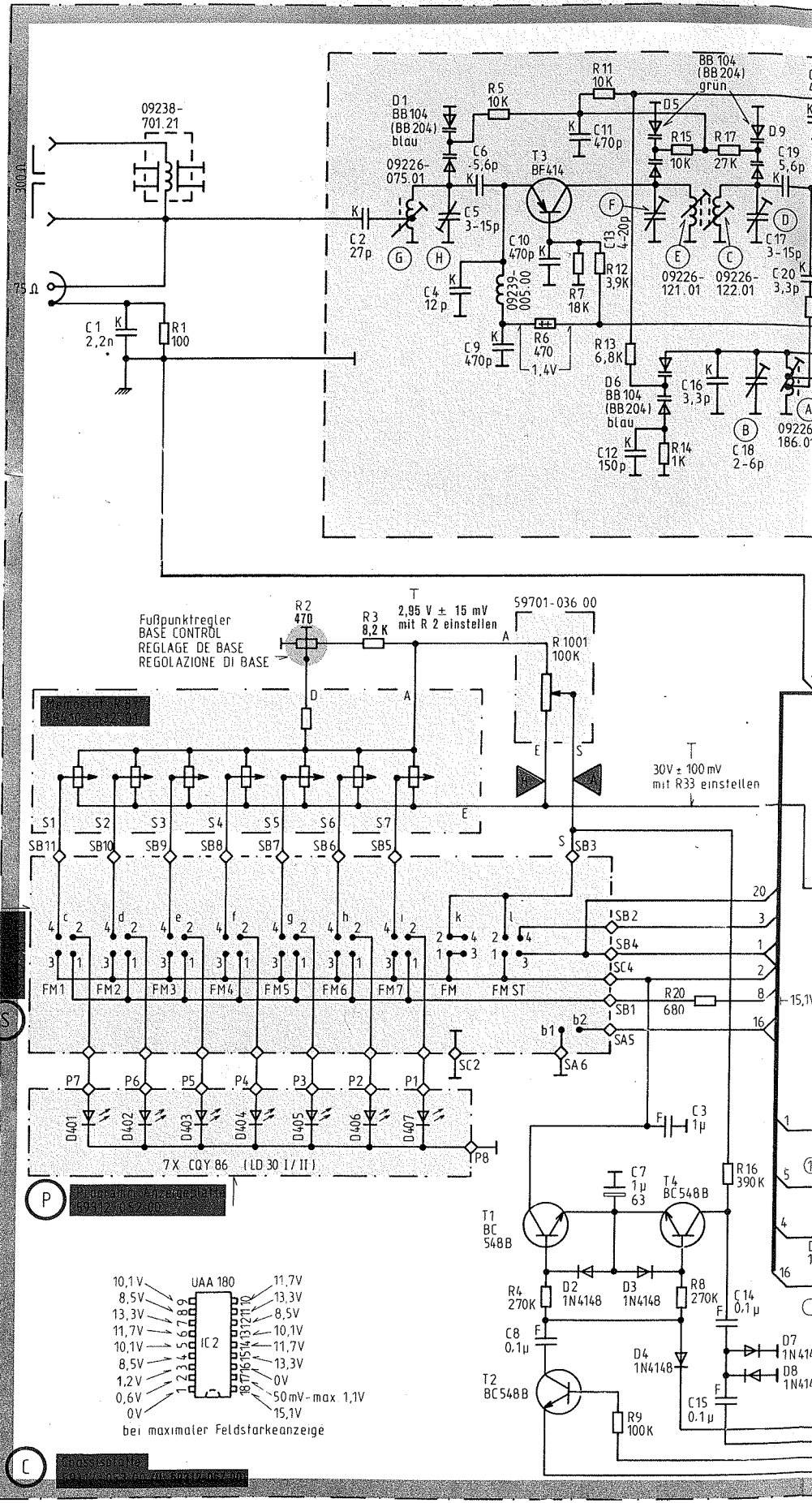

R_{D-E} = 15K ± 15%

U_{A-D} = 9% vom Wert U_{E-D}

Gleichrichter: B 30 C 300 0820-310.01 (04 / 05)

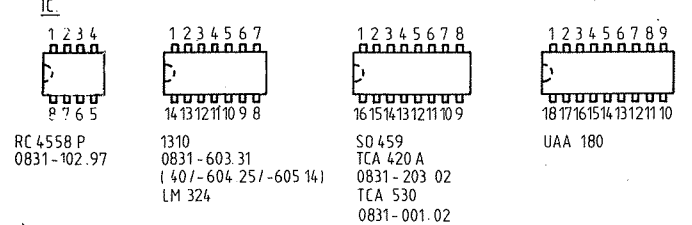

Ersatztypen in Klammer ()
INTERCH TYPES IN BRACKETS ()
TYPES DE RECHANGE EN PARENTHESE ()
TIPI DI RICAMBI IN ()

Ansicht von unten / BOTTOM VIEW / VUE DE DESSOUS / VISTA DA SOTTO

C	1,	2,	5, 4, 6, 9,	10, 11,	12, 13,	16, 17,	19, 21,
R	1,	2,	3,	5,	6, 7, 11, 13,	14, 15,	18, 20,
				1001, 8, 12,	4,	9,	8, 20, 16,

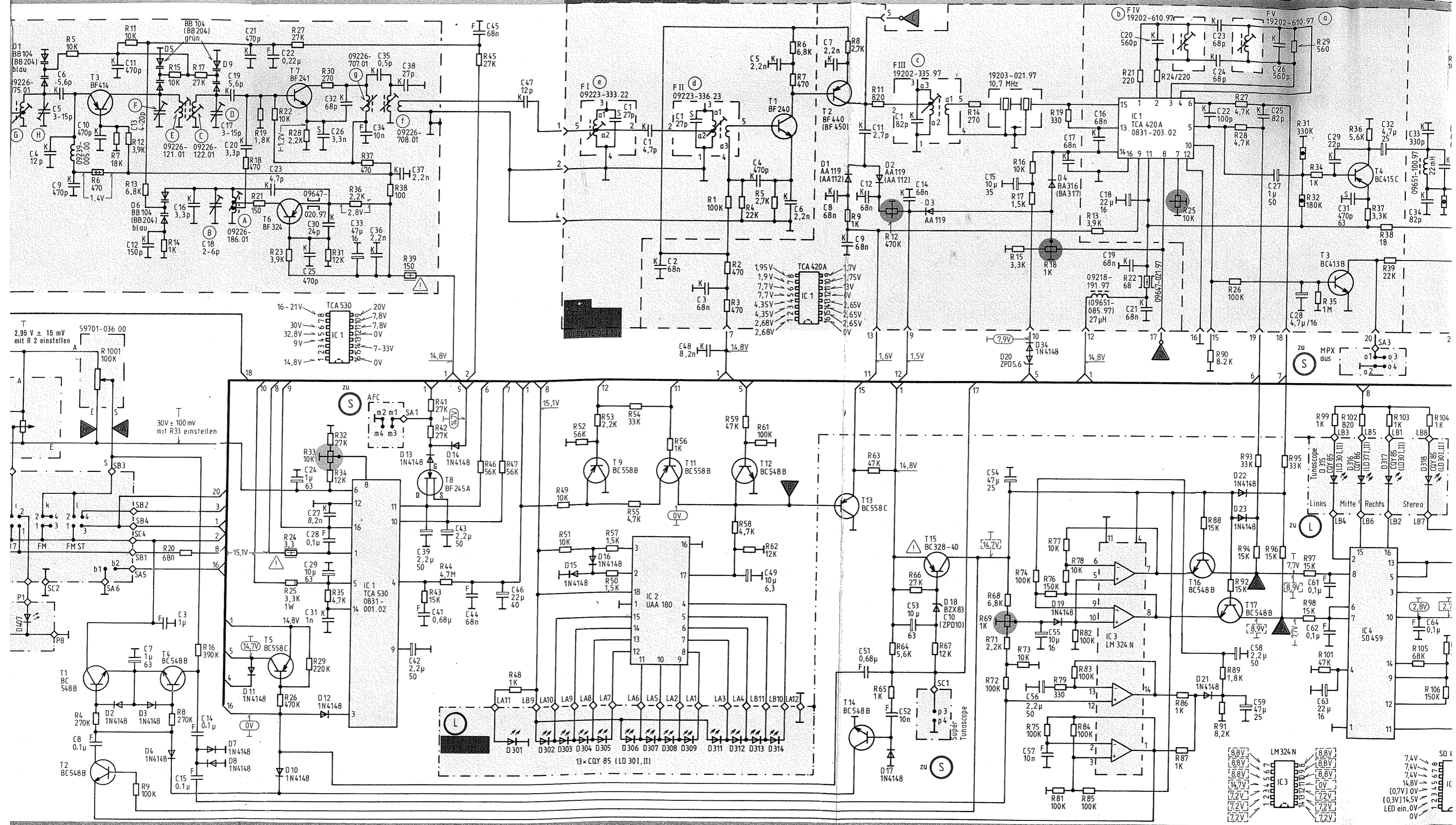

5, 4, 6, 9,	10, 11,	12, 13,	16, 17,	19, 21,	22,	24, 25, 26, 27, 31,	33, 34, 35,	37, 42, 39,	43,	45,	46, 47,	48,	49,	51,	52,	53,	54,	55, 57,	54,	56,	58, 59, 61,	63,	64,	66,	67,	68, 72, 73, 74, 76,	77, 81, 84,	86,	88,	89, 92,	93,	95,	97,	99,	102,	103,	105, 104,	107,		
8,	7,	3, 14, 15,	18,	20,	23,	28, 32,	29, 30,	36,	41,	44,	44,	45, 46,	47, 48,	49,	50,	55,	55,	56,	56,	56,	58, 59, 61,	62,	63,	64,	65,	69,	75,	78, 82, 85,	79, 83,	87,	90, 91,	94,	96,	98,	101,	102,	103,	105, 104,	107,	
5,	6,	7, 11,	13,	14, 15,	17,	18,	19, 22, 23, 27, 28,	30, 31, 32, 35, 36, 37,	38,	39,	41,	44,	45, 46,	47, 48,	49,	52,	53,	57,	54,	56,	58, 59, 61,	62,	63,	64,	65,	66,	67,	68, 72, 73, 74, 76,	77, 81, 84,	86,	88,	89, 92,	93,	95,	97,	99,	102,	103,	105, 104,	107,
4,	8,	9,	8,	20,	16,	21,	26, 24,	29,	33,	34,	42,	43,	43,	43,	51,	51,	50,	55,	55,	56,	58, 59, 61,	62,	63,	64,	65,	66,	67,	68, 72, 73, 74, 76,	77, 81, 84,	86,	88,	89, 92,	93,	95,	97,	99,	102,	103,	105, 104,	107,

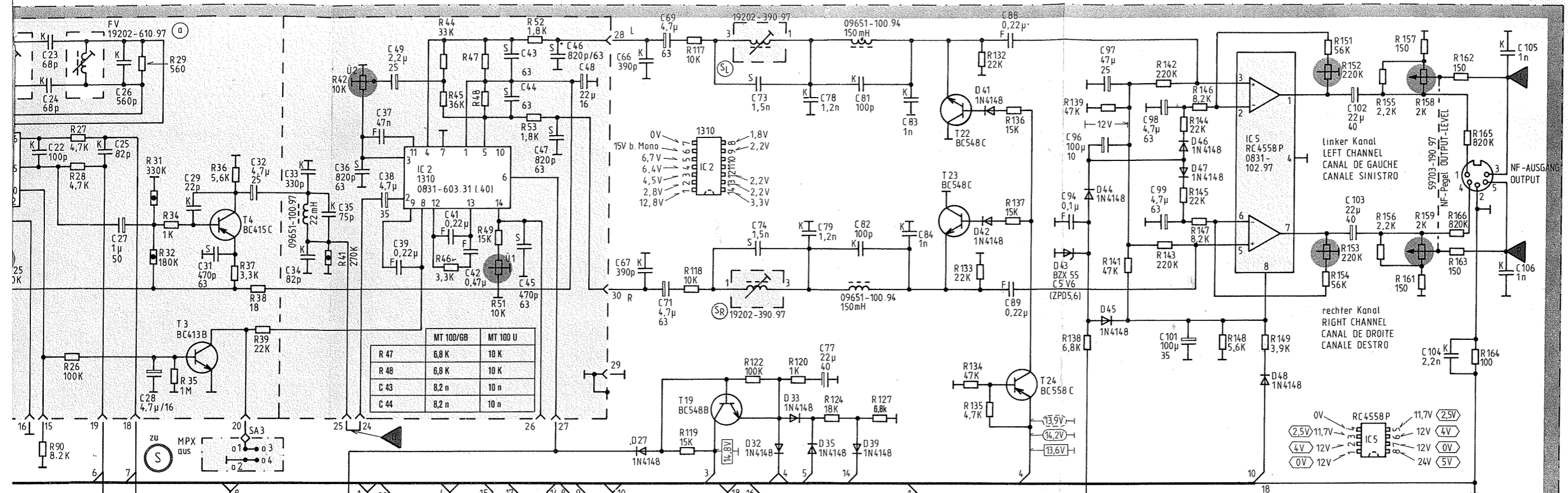

59800 - 650.00
 Automatische Stereumschaltung mit R 25 (10K) auf 20µV Antennenspannung (300Ω) einstellen. (Sender 19KHz, 7,5KHz Hub, moduliert)

SET R 25 (10K) TO OBTAIN AUTOMATIC STEREO SWITCHOVER WITH AN AERIAL INPUT SIGNAL OF 20µV ACROSS 300Ω (TRANSMITTER 19KHZ, 7,5KHZ DEVIATION, MOD WITH AUDIO SIGNAL)

REGLER LE SEUIL LA COMMUTATION AUTOMATIQUE STEREO PAR R 25 (10K) POUR UNE TENSION D'ANTENNE DE 20µV SUR 300Ω (EMMETEUR MODULE 19KHZ, EXCURSION 7,5 KHZ)

REGOLARE LA COMMUTAZIONE AUTOMATICA STEREO AGENDO SU R 25 (10K) PER UNA TENSIONI DI ANTENNA DI 20 MICROVOLT (300Ω). (GENERATORE 19KHZ, 7,5KHZ DI DEVIAZIONE, MODULATO)

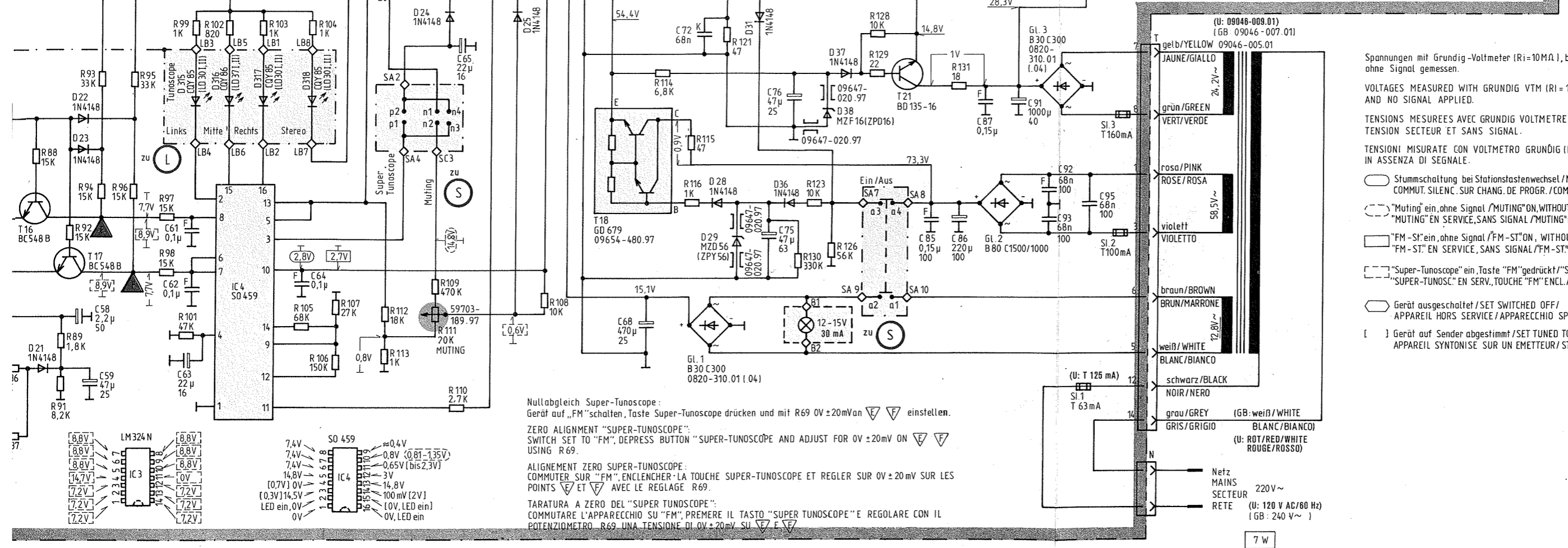

Nullabgleich Super-Tunoscopes:
 Gerät auf „FM“ schalten, Taste Super-Tunoscopes drücken und mit R 69 0V ± 20mV an ∇ ∇ einstellen.
 ZERO ALIGNMENT "SUPER-TUNOSCOPE":
 SWITCH SET TO "FM", DEPRESS BUTTON "SUPER-TUNOSCOPE" AND ADJUST FOR 0V ± 20mV ON ∇ ∇ USING R 69.
 ALIGNEMENT ZERO SUPER-TUNOSCOPE:
 COMMUTER SUR "FM", ENCLANCHER LA TOUCHE SUPER-TUNOSCOPE ET REGLER SUR 0V ± 20mV SUR LES POINTS ∇ ET ∇ AVEC LE REGLAGE R 69.
 TARATURA A ZERO DEL "SUPER TUNOSCOPE":
 COMMUTARE L'APPARECCHIO SU "FM", PREMERE IL TASTO "SUPER TUNOSCOPE" E REGOLARE CON IL POTENZIOMETRO R 69 UNA TENSIONE DI 0V ± 20mV SU ∇ ∇

- Spannungen mit Grundig-Voltmeter (Ri=10MΩ), bei 220V~ Netzspannung ohne Signal gemessen.
 VOLTAGES MEASURED WITH GRUNDIG VTM (RI=10 MΩ) AT 220V~ AC AND NO SIGNAL APPLIED.
 TENSIONS MESUREES AVEC GRUNDIG VOLTMETRE (RI=10 MΩ) A 220V~ TENSION SECTEUR ET SANS SIGNAL.
 TENSIONI MISURATE CON VOLTMETRO GRUNDIG (RI=10 MΩ) CON 220V~ IN ASSENZA DI SEGNALE.
- \square Stummschaltung bei Stationstastenwechsel / MUTING WHEN CHANGING STATIONS / COMMUT. SILENC. SUR CHANG. DE PROG. / COMMUT. SILENC. CON CAMBIO DELLE STAZIONI
 - \square "Muting" ein, ohne Signal / "MUTING" ON, WITHOUT SIGNAL / "MUTING" EN SERVICE, SANS SIGNAL / "MUTING" INSERITO, SENZA SEGNALE
 - \square "FM-St" ein, ohne Signal / "FM-ST" ON, WITHOUT SIGNAL / "FM-ST" EN SERVICE, SANS SIGNAL / "FM-ST" INSERITO, SENZA SEGNALE
 - \square "Super-Tunoscopes" ein, Taste "FM" gedrückt / "SUPER-TUNOSC" ON, BUTTON "FM" DEPRESSED / "SUPER-TUNOSC" EN SERV, TOUCHE "FM" ENCL. / "SUPER-TUNOSC" INSERITO, TASTO "FM" PREM.
 - \square Gerät ausgeschaltet / SET SWITCHED OFF / APPAREIL HORS SERVICE / APPARECCHIO SPENTO
 - [] Gerät auf Sender abgestimmt / SET TUNED TO STATION / APPAREIL SYNTONISE SUR UN EMETTEUR / STAZIONE SINTONIZZATA

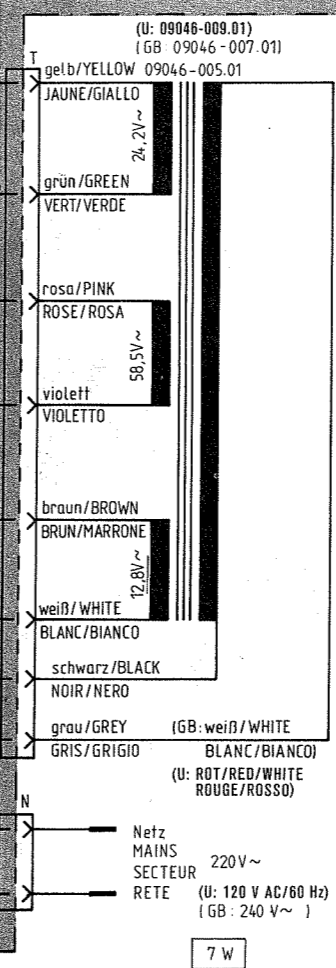

58, 59,	61,	64,	65,	66, 68, 69,	72,	73, 75,	76, 78,	81,	83,	85,	86,	87,	88, 91,	92,	94,	95, 96,	97,	98,	101,	102,	104,	105,	106,										
88, 89, 92,	93,	95,	97,	99,	102,	103,	105, 104,	107,	112,	109, 110,	108,	114,	117, 115,	121,	122,	123, 130,	124,	127,	131, 134, 132,	136,	138, 139,	141,	142, 144, 146,	148,	149,	151, 154,	155,	157, 161,	162,	164, 165,	166,		
7,	90, 91,	94,	96,	101,	106,	111,	113,	119,	118, 116,	119,	126,	128,	129,	133, 137,	135,	152,	153,	158,	159,	163,	166,												

GRUNDIG
MT 100/GB/U
 (55029-906.02)

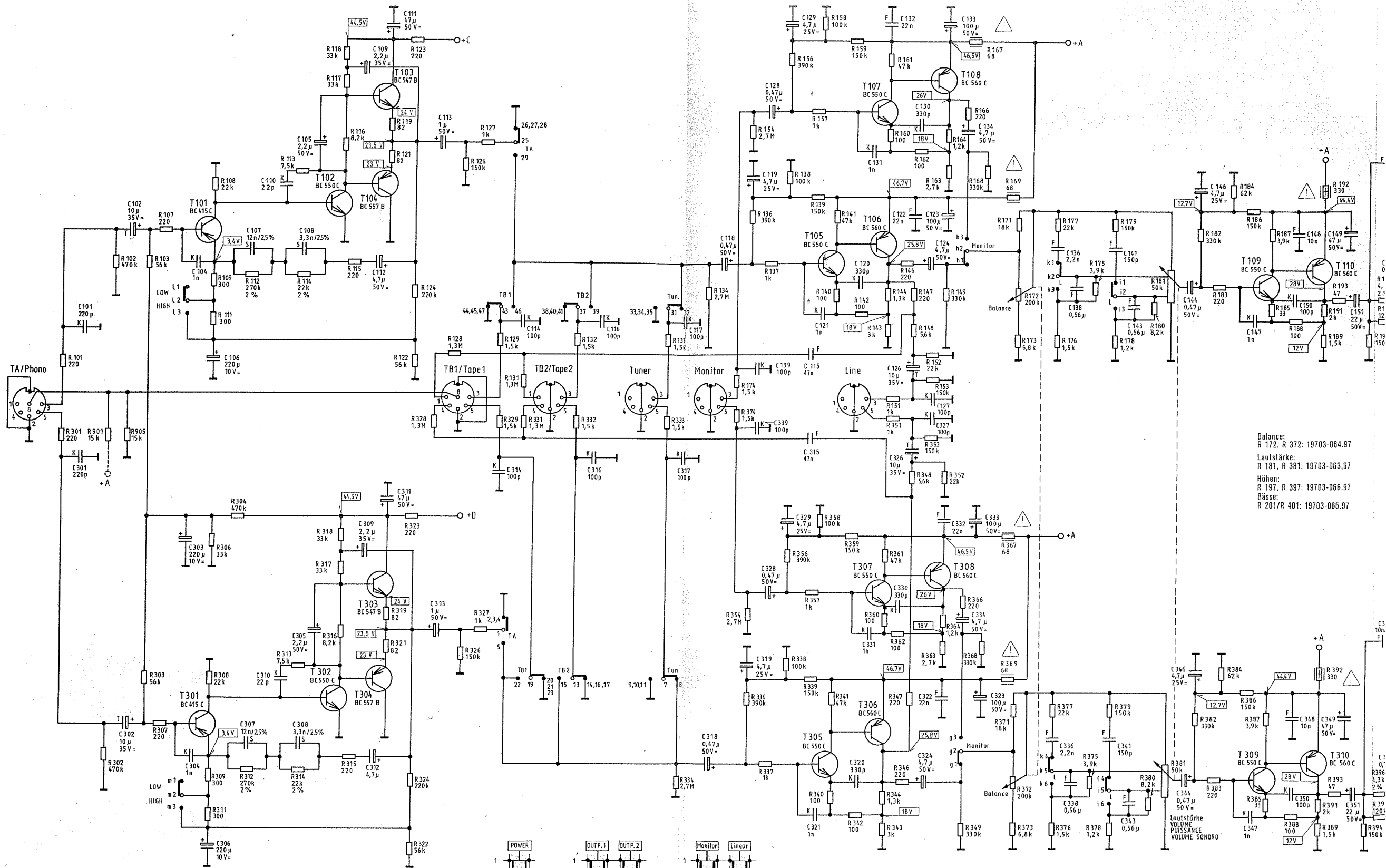

Balance: R 172, R 372: 19703-064.97
 Lautstärke: R 181, R 381: 19703-063.97
 Höhen: R 197, R 397: 19703-066.97
 Bässe: R 201/R 401: 19703-065.97

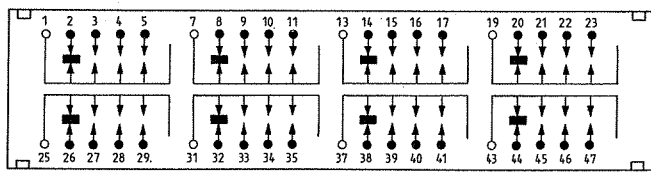

gezeichnet in Stellung: Tuner
 SHOWN POSITION: TUNER
 MONTRE EN POSITION: TUNER
 RAPPRESENTATO IN POS.: TUNER

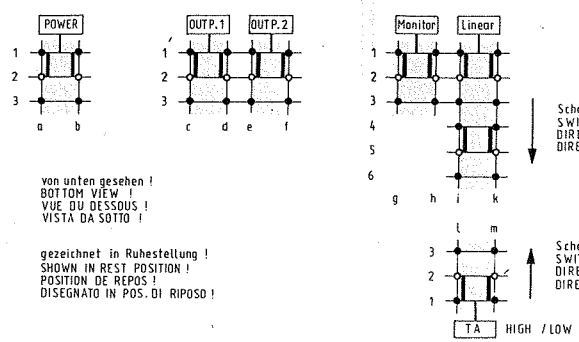

von unten gesehen!
 BOTTOM VIEW!
 VUE DU DESSOUS!
 VISTA DA SOTTO!

gezeichnet in Ruhestellung!
 SHOWN IN REST POSITION!
 POSITION DE REPOS!
 DISEGNATO IN POS. DI RIPOSO!

Schaltrichtung!
 SWITCHING DIRECTION!
 DIRECTION DE COMMUTATION!
 DIREZIONE DI COMMUTAZIONE!

Schaltrichtung!
 SWITCHING DIRECTION!
 DIRECTION DE COMMUTATION!
 DIREZIONE DI COMMUTAZIONE!

C:	101, 301,	102, 302,	104, 304,	106, 306,	107, 307,	110, 310,	108, 308,	105, 305,	109, 309,	112, 312,	111, 311,	113, 313,	114, 314,	116, 316,	117, 317,	118, 318,	119, 319,	128, 328,	138, 338,	129, 329,	115, 315,	121, 321,	120, 320,	131, 331,	130, 330,	126, 326,	127, 327,	124, 324,	122, 322,	123, 323,	134, 334,	132, 332,	133, 333,	136, 336,	138, 338,	141, 341,	143, 343,	144, 344,	146, 346,	147, 347,	148, 348,	150, 350,	149, 349,	151, 351,	152, 352,	153, 353,	154, 354,	155, 355,	156, 356,	157, 357,	158, 358,	159, 359,	160, 360,	161, 361,	162, 362,	163, 363,	164, 364,	165, 365,	166, 366,	167, 367,	168, 368,	169, 369,	170, 370,	171, 371,	172, 372,	173, 373,	174, 374,	175, 375,	176, 376,	177, 377,	178, 378,	179, 379,	180, 380,	181, 381,	182, 382,	183, 383,	184, 384,	186, 386,	187, 387,	188, 388,	189, 389,	190, 390,	191, 391,	192, 392,	193, 393,	194, 394,	195, 395,
R:	101, 301,	901, 302,	102, 303,	905, 307,	103, 307,	107, 308,	108, 309,	309, 311,	306, 312,	111, 313,	112, 314,	113, 315,	114, 316,	116, 317,	117, 318,	118, 319,	119, 320,	128, 328,	138, 329,	139, 330,	129, 331,	115, 332,	121, 333,	120, 334,	131, 335,	130, 336,	126, 337,	127, 338,	124, 339,	122, 340,	123, 341,	134, 342,	132, 343,	133, 344,	136, 345,	138, 346,	141, 347,	143, 348,	144, 349,	146, 350,	147, 351,	148, 352,	150, 353,	149, 354,	151, 355,	152, 356,	153, 357,	154, 358,	155, 359,	156, 360,	157, 361,	158, 362,	159, 363,	160, 364,	161, 365,	162, 366,	163, 367,	164, 368,	165, 369,	166, 370,	167, 371,	168, 372,	169, 373,	170, 374,	171, 375,	172, 376,	173, 377,	174, 378,	175, 379,	176, 380,	177, 381,	178, 382,	179, 383,	180, 384,	182, 386,	183, 387,	184, 388,	186, 389,	187, 390,	188, 391,	189, 392,	190, 393,	191, 394,	192, 395,	193, 396,	194, 397,	195, 398,

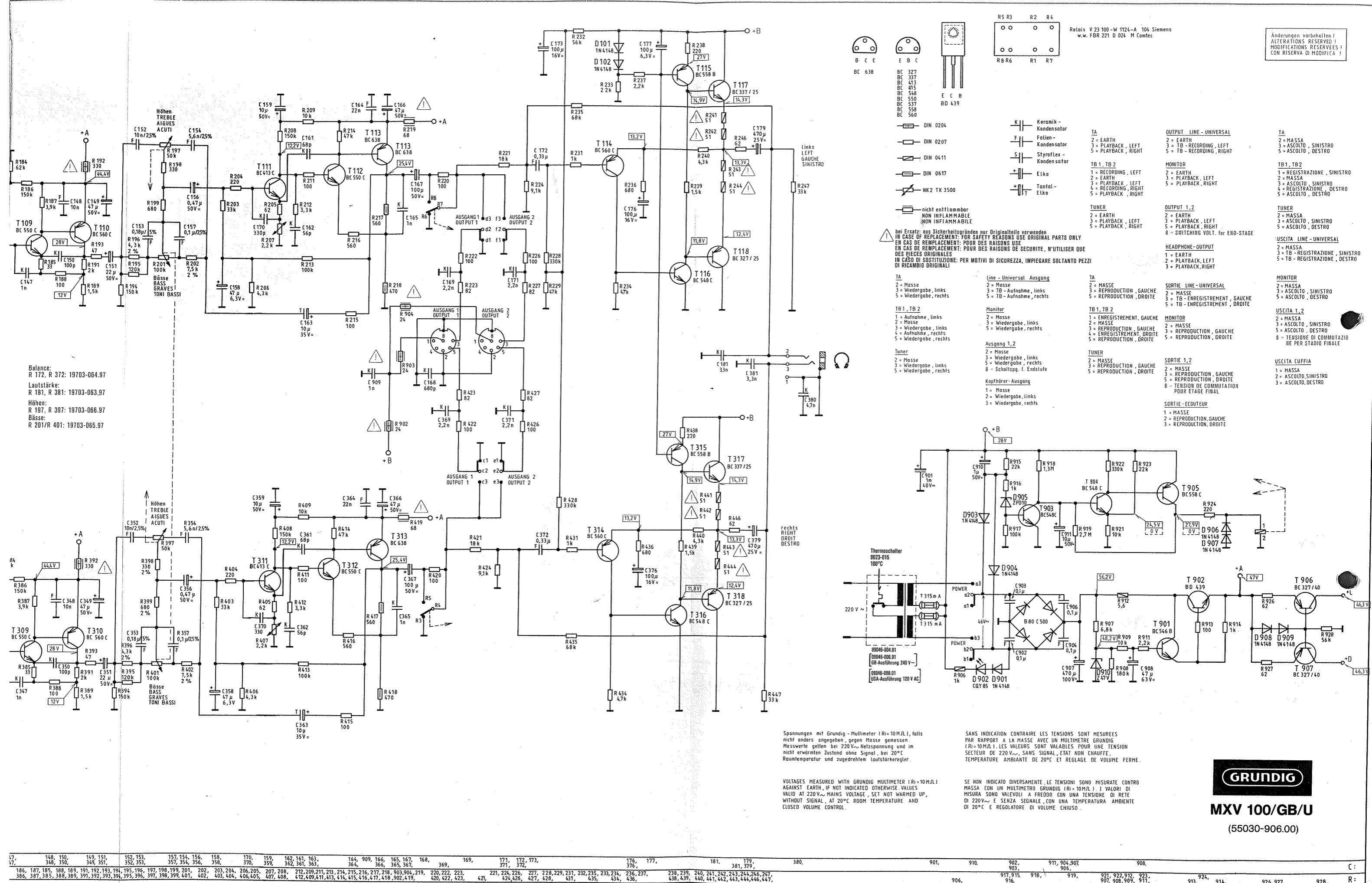

Balance:
R 172, R 372: 19703-064.97
Lautstärke:
R 181, R 381: 19703-063.97
Höhen:
R 197, R 397: 19703-066.97
Bässe:
R 201/R 401: 19703-066.97

Höhen TREBLE
AIGUES ACUTI
C152 10n/25%
C154 5,6n/25%
Bässe BASS
GRAVES
TONI BASSI
C352 10n/25%
R397 50k
C356 0,47µ 50V=
C357 0,1µ/25%
C358 4,3k 2%
C359 10µ 50V=
C360 0,47µ 50V=
C361 68p
C362 33k
C363 10µ 35V=
C364 22n
C365 1n
C366 47µ 50V=
C367 100µ 50V=
C368 4,3k
C369 2,2k
C370 330
C371 2,2k
C372 0,33µ
C373 10µ 16V=
C374 10µ 16V=
C375 10µ 16V=
C376 100µ 16V=
C377 2,2k
C378 2,2k
C379 470µ 25V=
C380 4,7n

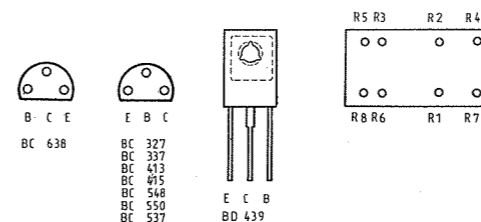

Relais V 23 100-W 1124-A 104 Siemens
w.w. FBR 221 D 024 M Comtec

Änderungen vorbehalten!
ALTERATIONS RESERVED!
MODIFICAZIONI RISERVATE!
CON RISERVA DI MODIFICA!

- BC 327
 - BC 337
 - BC 413
 - BC 405
 - BC 540
 - BC 550
 - BC 557
 - BC 558
 - BC 560
- K Keramikkondensator
 F Folienkondensator
 S Styroflexkondensator
 + Elko
 + Tantal-Elko
- bei Ersatz: aus Sicherheitsgründen nur Originalteile verwenden
 IN CASE OF REPLACEMENT: FOR SAFETY REASONS USE ORIGINAL PARTS ONLY
 EN CAS DE REMPLACEMENT: POUR DES RAISONS DE SECURITE, N'UTILISER QUE DES PIECES ORIGINALES
 IN CASO DI SOSTITUZIONE: PER MOTIVI DI SICUREZZA, IMPIEGARE SOLTANTO PEZZI DI RICAMBIO ORIGINALI
- Line-Universal Ausgang**
 2 = Masse
 3 = TB - Aufnahme, links
 5 = Wiedergabe, rechts
- Monitor**
 2 = Masse
 3 = Wiedergabe, links
 5 = Wiedergabe, rechts
- Ausgang 1,2**
 2 = Masse
 3 = Wiedergabe, links
 5 = Wiedergabe, rechts
 8 = Schallspg. f. Endstufe
- Kopfhörer-Ausgang**
 1 = Masse
 2 = Wiedergabe, links
 3 = Wiedergabe, rechts
- TA**
 2 = MASSE
 3 = REPRODUCTION, GAUCHE
 5 = REPRODUCTION, DROITE
- TB 1, TB 2**
 1 = ENREGISTREMENT, GAUCHE
 2 = MASSE
 3 = REPRODUCTION, GAUCHE
 4 = ENREGISTREMENT, DROITE
 5 = REPRODUCTION, DROITE
- TUNER**
 2 = MASSE
 3 = REPRODUCTION, GAUCHE
 5 = REPRODUCTION, DROITE
- Sortie-Line-Universal**
 2 = MASSE
 3 = REPRODUCTION, GAUCHE
 5 = REPRODUCTION, DROITE
- Sortie-Monitor**
 2 = MASSE
 3 = REPRODUCTION, GAUCHE
 5 = REPRODUCTION, DROITE
- Sortie-Ausgang 1,2**
 2 = MASSE
 3 = REPRODUCTION, GAUCHE
 5 = REPRODUCTION, DROITE
 8 = TENSION DE COMMUTATION NE PER STADIO FINALE
- USCITA LINE-UNIVERSAL**
 2 = MASSA
 3 = ASCOLTO, SINISTRO
 5 = ASCOLTO, DESTRO
- USCITA MONITOR**
 2 = MASSA
 3 = ASCOLTO, SINISTRO
 5 = ASCOLTO, DESTRO
- USCITA 1,2**
 2 = MASSA
 3 = ASCOLTO, SINISTRO
 5 = ASCOLTO, DESTRO
 8 = TENSIONE DI COMMUTAZIONE NE PER STADIO FINALE
- USCITA CUFFIA**
 1 = MASSA
 2 = ASCOLTO, SINISTRO
 3 = ASCOLTO, DESTRO

Spannungen mit Grundig-Multimeter (Ri=10MΩ), falls nicht anders angegeben, gegen Masse gemessen. Messwerte gelten bei 220V~ Netzspannung und im nicht erwärmten Zustand ohne Signal, bei 20°C Raumtemperatur und zugehörtem Lautstärkeregel.

SANS INDICATION CONTRAIRE LES TENSIONS SONT MESUREES PAR RAPPORT A LA MASSE AVEC UN MULTIMETRE GRUNDIG (Ri=10MΩ). LES VALEURS SONT VALABLES POUR UNE TENSION SECTEUR DE 220V~, SANS SIGNAL, ETAT NON CHAUFFE, TEMPERATURE AMBIANTE DE 20°C ET REGLAGE DE VOLUME FERME.

VOLTAGES MEASURED WITH GRUNDIG MULTIMETER (Ri=10MΩ) AGAINST EARTH, IF NOT INDICATED OTHERWISE VALUES VALID AT 220V~ MAINS VOLTAGE, SET NOT WARMED UP, WITHOUT SIGNAL, AT 20°C ROOM TEMPERATURE AND CLOSED VOLUME CONTROL.

SE NON INDICATO DIVERSAMENTE, LE TENSIONI SONO MISURATE CONTRO MASSA CON UN MULTIMETRO GRUNDIG (Ri=10MΩ). I VALORI DI MISURA SONO VALEVOLI A FREDDO CON UNA TENSIONE DI RETE DI 220V~ E SENZA SEGNALE, CON UNA TEMPERATURA AMBIANTE DI 20°C E REGOLATORE DI VOLUME CHIUSO.

GRUNDIG
MXV 100/GB/U
(55030-906.00)

17,	148, 150,	149, 151,	152, 153,	157, 154, 156,	158,	170,	159,	162, 161, 163,	164,	909, 166,	165, 167,	168,	176,	177,	181,	179,	380,	901,	910,	902,	911, 904, 907,	908,	C :									
186, 187, 185,	188, 189,	191, 192, 193, 194,	195, 196,	197, 198, 199, 201,	202,	203, 204,	206, 205,	207, 208,	212, 209, 211, 213,	214, 215, 216, 217, 218,	903, 904, 219,	220, 222, 223,	221, 224, 226,	227,	228, 229, 231,	232, 235,	233, 234,	236, 237,	238, 239,	240, 241, 242, 243, 244, 245, 247,	438, 439,	440, 441, 442, 443, 444, 446, 447,	906,	917, 915,	918,	919,	921, 922, 912, 923,	924,	914,	926, 927,	928,	R :
366, 367, 365, 368, 369,	391, 392, 393, 395,	395, 396,	397, 398, 399, 401,	402,	403, 404,	406, 405,	407, 408,	412, 409, 411, 413, 414,	415, 416, 417, 418, 902, 419,	420, 422, 423,	421,	424, 426,	427, 428,	431,	435,	434,	436,	438, 439,	440, 441, 442, 443, 444, 446, 447,	906,	917, 915,	918,	919,	921, 922, 912, 923,	924,	914,	926, 927,	928,	R :			

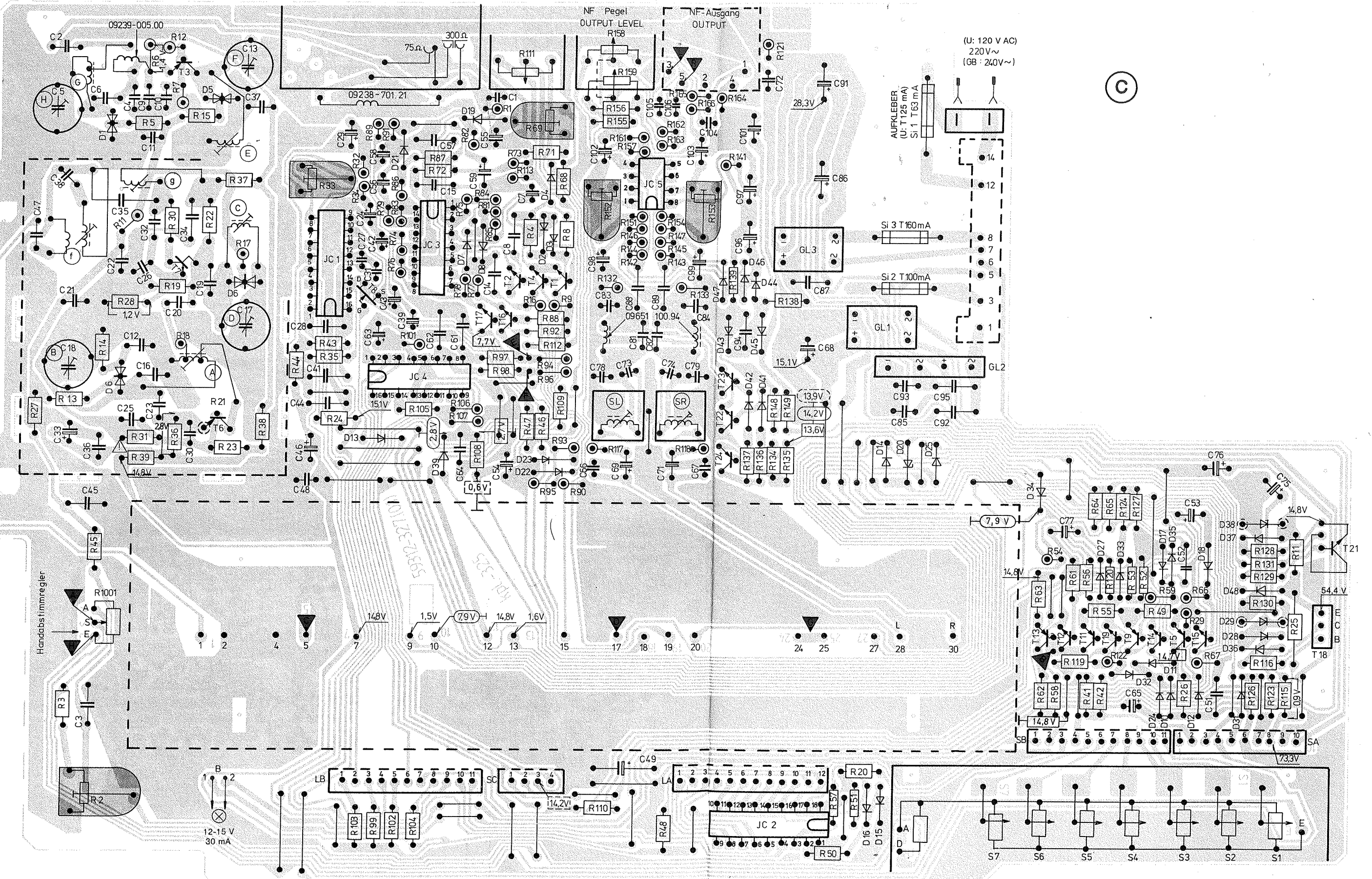

Druckschaltungsplatte, Lötseite MT 100/GB: 59312-053.00
PRINTED CIRCUIT BOARD, SOLDER SIDE
PLAQUE DES CIRCUITS IMPRIMES, COTE DES SOUDURES
PIASTRA DI COMANDO A PRESSIONE, LATO SALDATURE

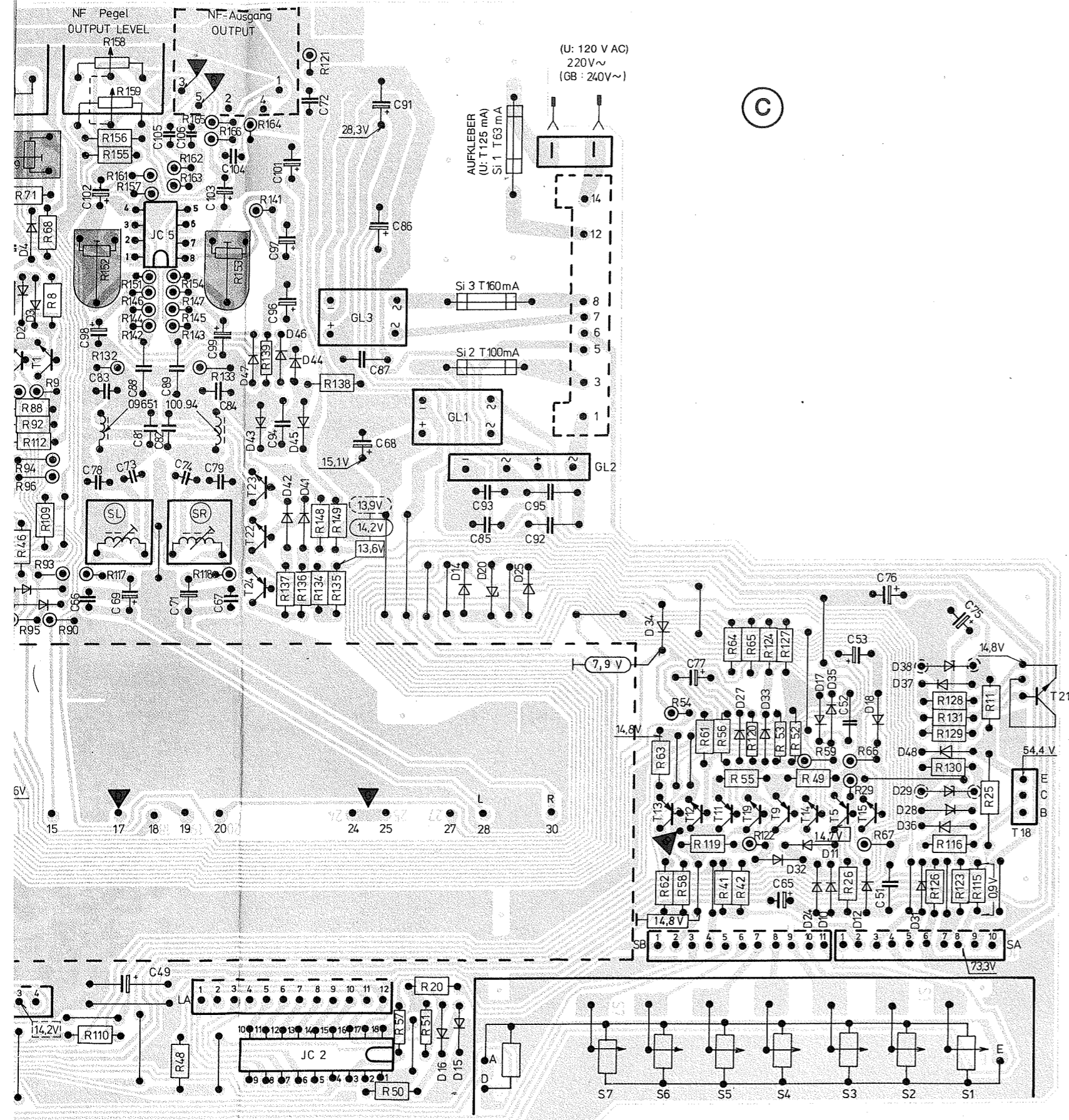

ZF-PLL-Decoder, Lötseite 59315-110.00 (U: 59315-004.00)
IF-PLL-DECODER, SOLDER SIDE
DECODEUR FI-PLL, COTE SOUDURES
DECODER FREQUENZA FI-PLL, LATO SALDATURE

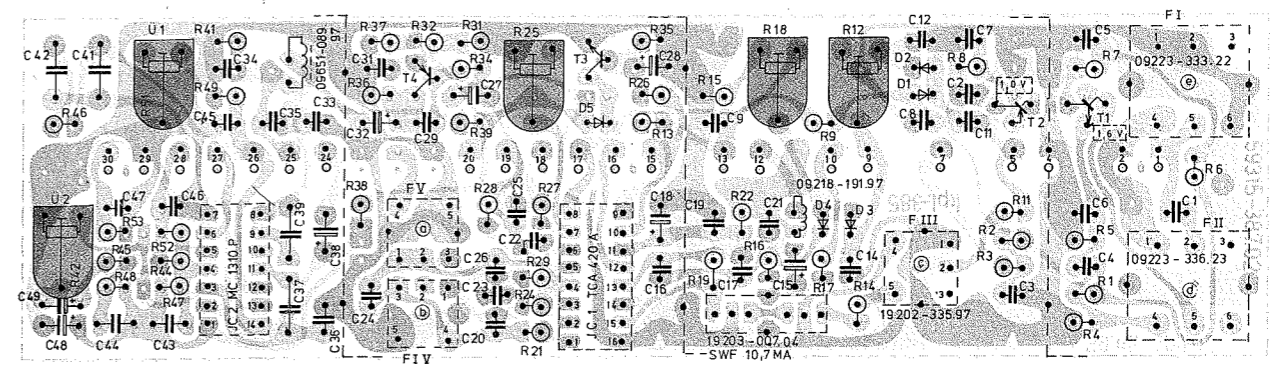

LED-Platte, Lötseite 59315-121.00
LED BOARD, SOLDER SIDE
CIRCUIT IMPRIME LEDs, COTE SOUDURES
PIASTRA LED, LATO SALDATURE

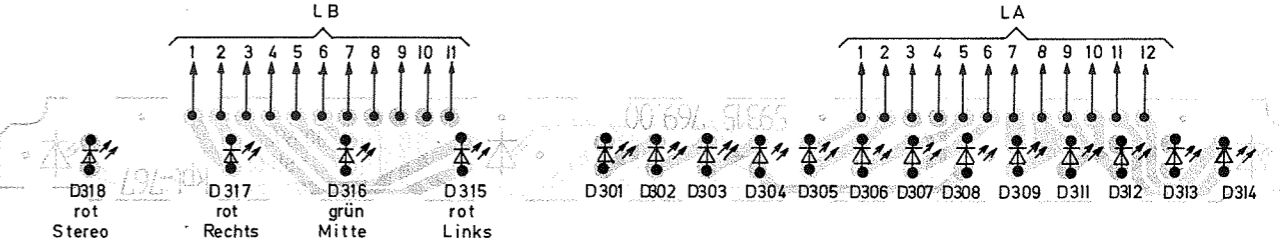

Schalterplatte, Lötseite 59312-137.00
SWITCH BOARD, SOLDER SIDE
CIRCUIT IMPRIME COMMUTATEURS, COTE SOUDURES
PIASTRA COMMUTATORI, LATO SALDATURE

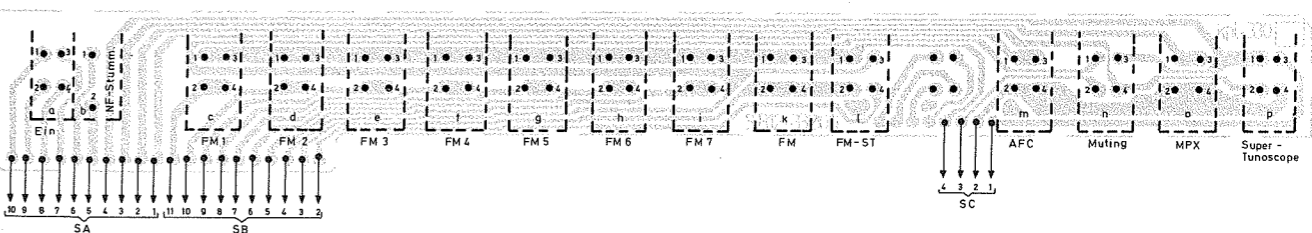

Programmanzeige-Platte, Lötseite 59312-052.00
PROGRAMME INDICATION BOARD, SOLDER SIDE
CIRCUIT IMPRIME INDICATION Progr., COTE SOUDURES
PIASTRA INDICAZIONE PROGRAMMI, LATO SALDATURE

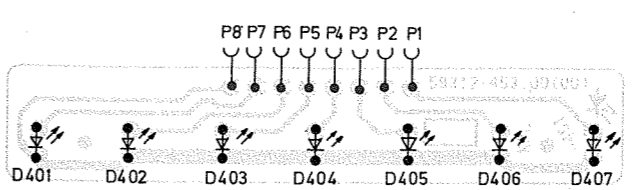

Lötseite
SOLDER SIDE
COTE DES SOUDURES
LATO SALDATURE

Bestückungsseite
COMPONENT SIDE
VUE DU COTE DES COMPOSANTS
LATO COMPONENTI

FM-Seilzug

SEILLÄNGE I CA. 418 mm

SEILLÄNGE II CA. 256 mm

FM Drive Cord

CORD LENGTH I APPROX. 418 mm

CORD LENGTH II APPROX. 256 mm

Entraînement FM

LONGUEUR DE LA CORDE I ENV. 418 mm

LONGUEUR DE LA CORDE II ENV. 256 mm

Montaggio della funicella

LUNGHEZZA DELLA FUNICELLA I CA. 418 mm

LUNGHEZZA DELLA FUNICELLA II CA. 256 mm

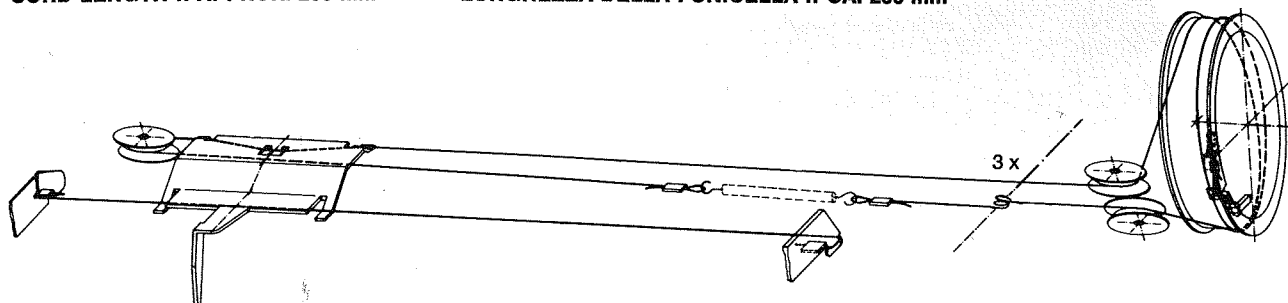

Notizen:

A series of horizontal dotted lines for taking notes.

TA / Phono

TB1/ Tape 1

TB 2 / Tape 2

Tuner

Line

Monitor

Ausgang 2

Ausgang 1

(A)

Druckschaltungsplatte, Lötseite MXV 100/GB/U
PRINTED CIRCUIT BOARD, SOLDER SIDE
PLAQUE DES CIRCUITS IMPRIMES, COTE DE SOUDURES
PIASTRA DI COMANDO A PRESSIONE, LATO SALDATURA

Lötseite
SOLDER SIDE
COTE DES SOUDURES
LATO SALDATURA

Bestückungsseite
COMPONENT SIDE
VUE DU COTE DES COMPOSANTS
LATO COMPONENTI

