

Technische Daten

Empfangsbereiche

UKW FM 87,5... 108 MHz
 MW 513... 1620 kHz
 (für USA umrüstbar auf 520... 1620 kHz)
 LW 146... 353 kHz
 (umrüstbar auf 153... 351 kHz durch Fachhändler)

FM-Empfindlichkeiten (75 Ω, 40 kHz Hub)

UKW-Mono: $\leq 1 \mu\text{V}$ für 26 dB S/R-Abstand
 UKW-Stereo: $\leq 35 \mu\text{V}$ für 46 dB S/R-Abstand

Stereo-Umschaltsschwelle

Stereo ein/aus: $< 25 / < 18 \mu\text{V}$ bei 98 MHz an 75 Ω

Muting-Schwelle

Muting ein/aus: $< 18 / < 25 \mu\text{V}$ bei 98 MHz an 75 Ω

FM-Fremdspannungsabstand

gemessen im Bereich 31,5 Hz... 15000 Hz, bei
 40 kHz Hub und 1 mV an 75 Ω.
 Spitzenwert nach DIN 45405/Effektivwert
 Mono $\geq 68/72$ dB; Stereo $\geq 66/70$ dB

FM-Geräuschspannungsabstand

bei 1 mV an 75 Ω gemessen bei 40 kHz.
 Spitzenwert nach DIN/Effektivwert über Kurve »A«:
 Mono $\geq 67/75$ dB; Stereo $\geq 64/73$ dB.

Übertragungsbereich bei FM

bei Ant. bis NF-Ausg. 10 Hz-15 kHz ≤ 3 dB

Klirrfaktor

Mono/Stereo: $\leq 0,2/0,4\%$ bei 1 kHz und 40 kHz Hub,
 gemessen nach DIN 45500 bei 1 mV an 75 Ω

Dynamische Trennschärfe

Mono: ≥ 70 dB; Stereo: ≥ 65 dB
 (± 300 kHz, auf bez. 40 kHz Hub,
 -30 dB Störspannung)

FM-Übersprechdämpfung

1 mV Antennenspannung, 47,5 kHz Gesamthub
 1 kHz ≥ 40 dB selektiv gemessen

Technical Specification

Waveband Coverage

VHF/FM 87.5... 108 MHz
 MW 513... 1620 kHz
 (convertible to 520... 1620 kHz for USA)
 LW 146... 353 kHz
 (convertible to 153... 351 kHz)

FM Sensitivities (75 Ω, 40 kHz deviation)

FM Mono: $\leq 1 \mu\text{V}$ with S/N ratio of 26 dB
 FM Stereo: $\leq 35 \mu\text{V}$ with S/N ratio of 46 dB

Stereo Switch-over Threshold

Stereo on/off: $< 25 / < 18 \mu\text{V}$ at 98 MHz into 75 Ω

Muting threshold

Muting on/off: $< 18 / < 25 \mu\text{V}$ at 98 MHz into 75 Ω

FM Signal-to-Noise Ratio (Unweighted)

in the range 31,5 Hz... 15000 Hz
 (deviation 40 kHz and 1 V into 75 Ω)
 Peak value to DIN 45505/rms value:
 Mono: $\geq 68/72$ dB; Stereo: $\geq 66/70$ dB

FM Signal-to-Noise Ratio (Weighted)

Measured at 1 mV into 75 Ω (40 kHz deviation)
 Peak value to DIN/rms value to curve "A"
 Mono: $\geq 67/75$ dB; Stereo: $\geq 64/73$ dB.

Frequency Response (VHF/FM)

from aerial to output: 10 Hz-15 kHz ≤ 3 dB

Distortion Factor

Mono/Stereo: $\leq 0,2/0,4\%$ bei 1 kHz und 40 kHz
 deviation at 1 mV into 75 Ω (to DIN 45500)

Dynamic Selectivity

Mono: ≥ 70 dB; Stereo: ≥ 65 dB
 (± 300 kHz, referred to 40 kHz deviation,
 -30 dB noise)

FM Crosstalk

1 mV at aerial and 47.5 kHz total deviation;
 1 kHz ≥ 40 dB measured at selected points

HF-Baustein, Lötseite 59420-032.00
HF MODULE, SOLDER SIDE
MODULE HF, COTE DES SOUDURES
MODULO AF, LATO SALDATURE

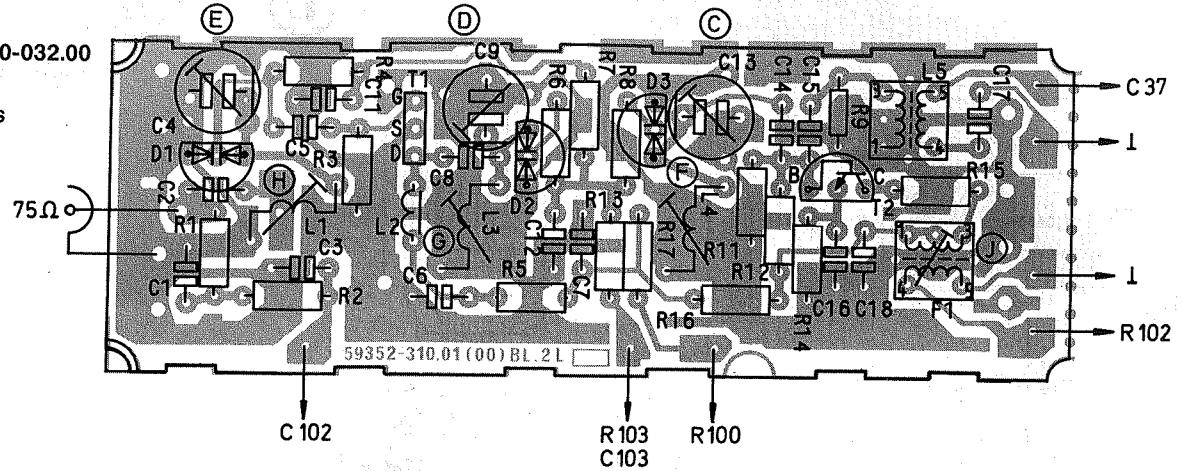

Oszillator-Baustein, Lötseite 59420-035.00
OSCILLATOR MODULE, SOLDER SIDE
MODULE OSCILLATEUR, COTE SOUDURES
MODULO OSCILLATORE, LATO SALDATURE

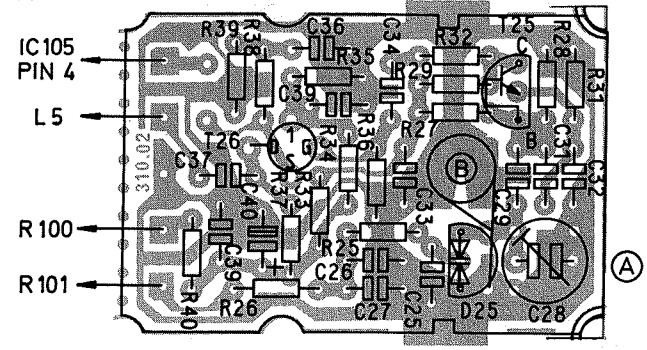

Lötseite
SOLDER SIDE
COTE DES SOUDURES
LATO SALDATURE

(BR)

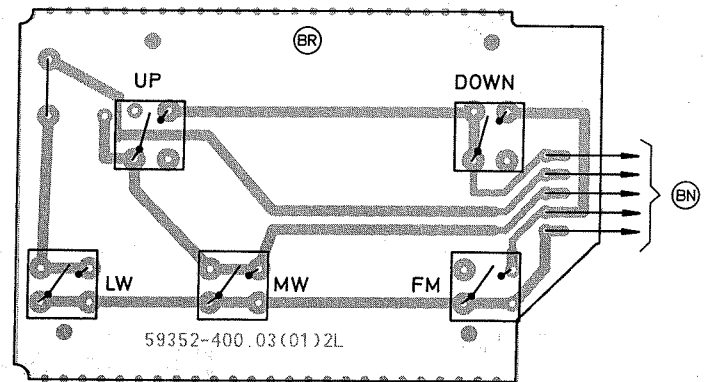

(BN)

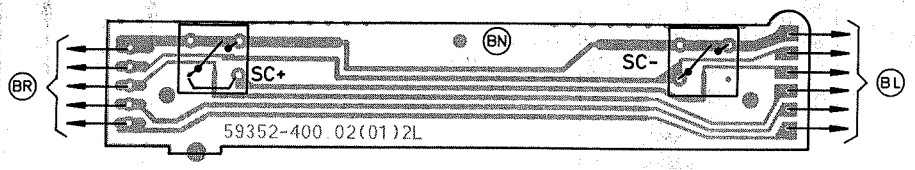

(BL)

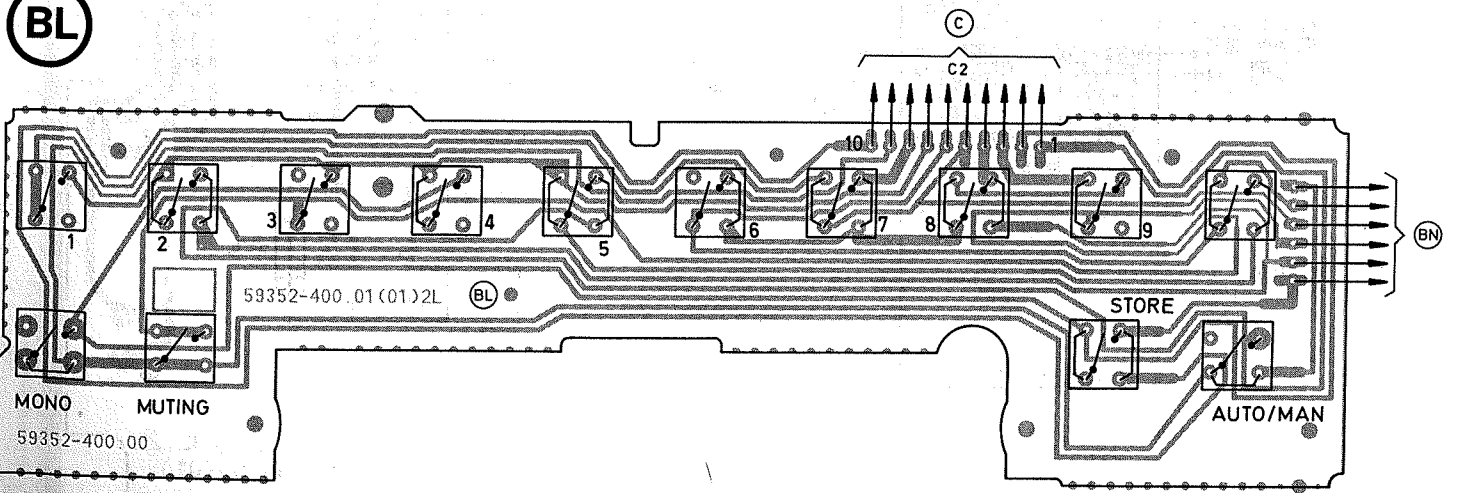

DISPLAY-ANZEIGE

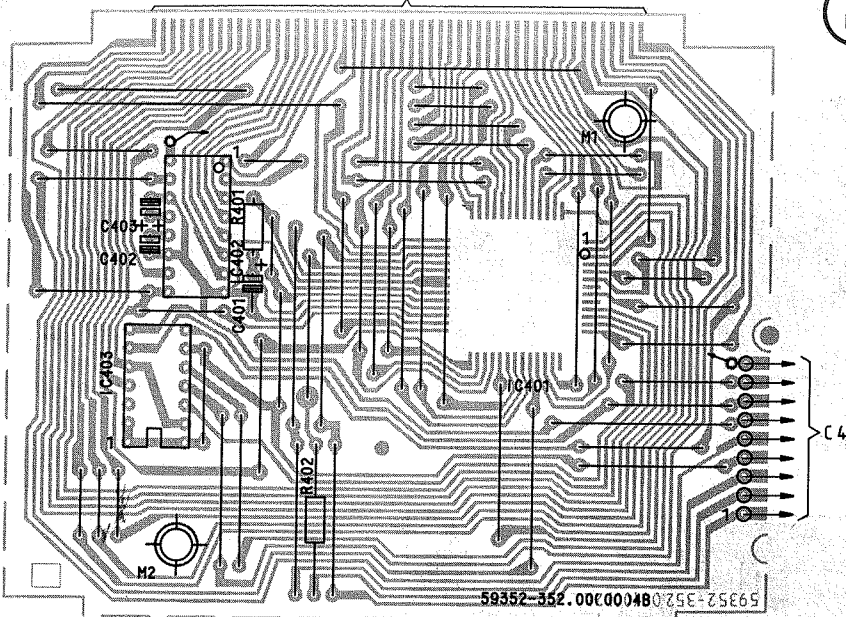

(D)

(N)

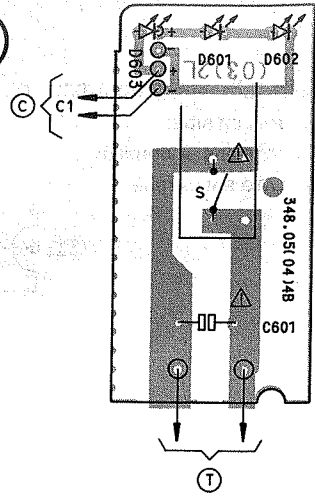

(L)

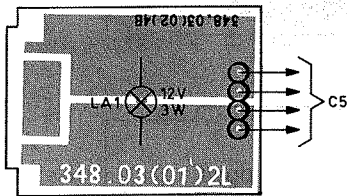

Lötseite
SOLDER SIDE
COTE DES SOUDURES
LATO SALDATURA

(A)

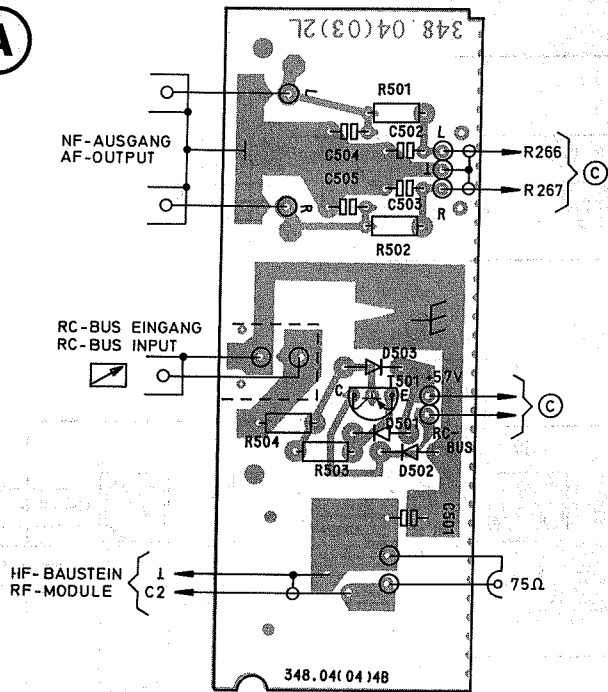

(T)

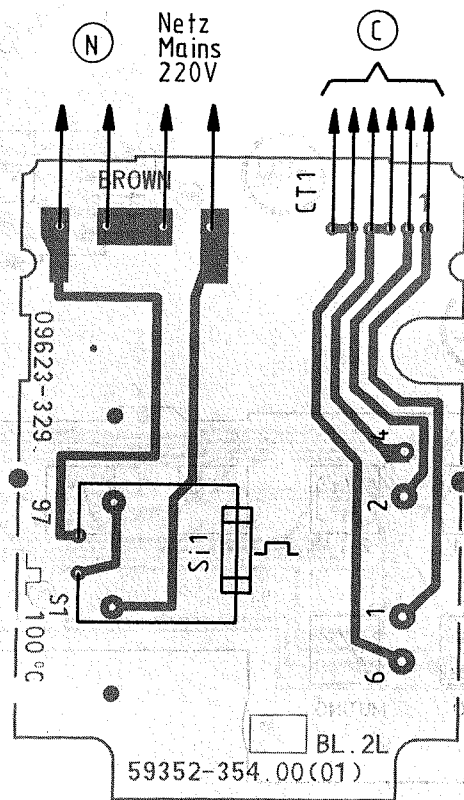

(C)

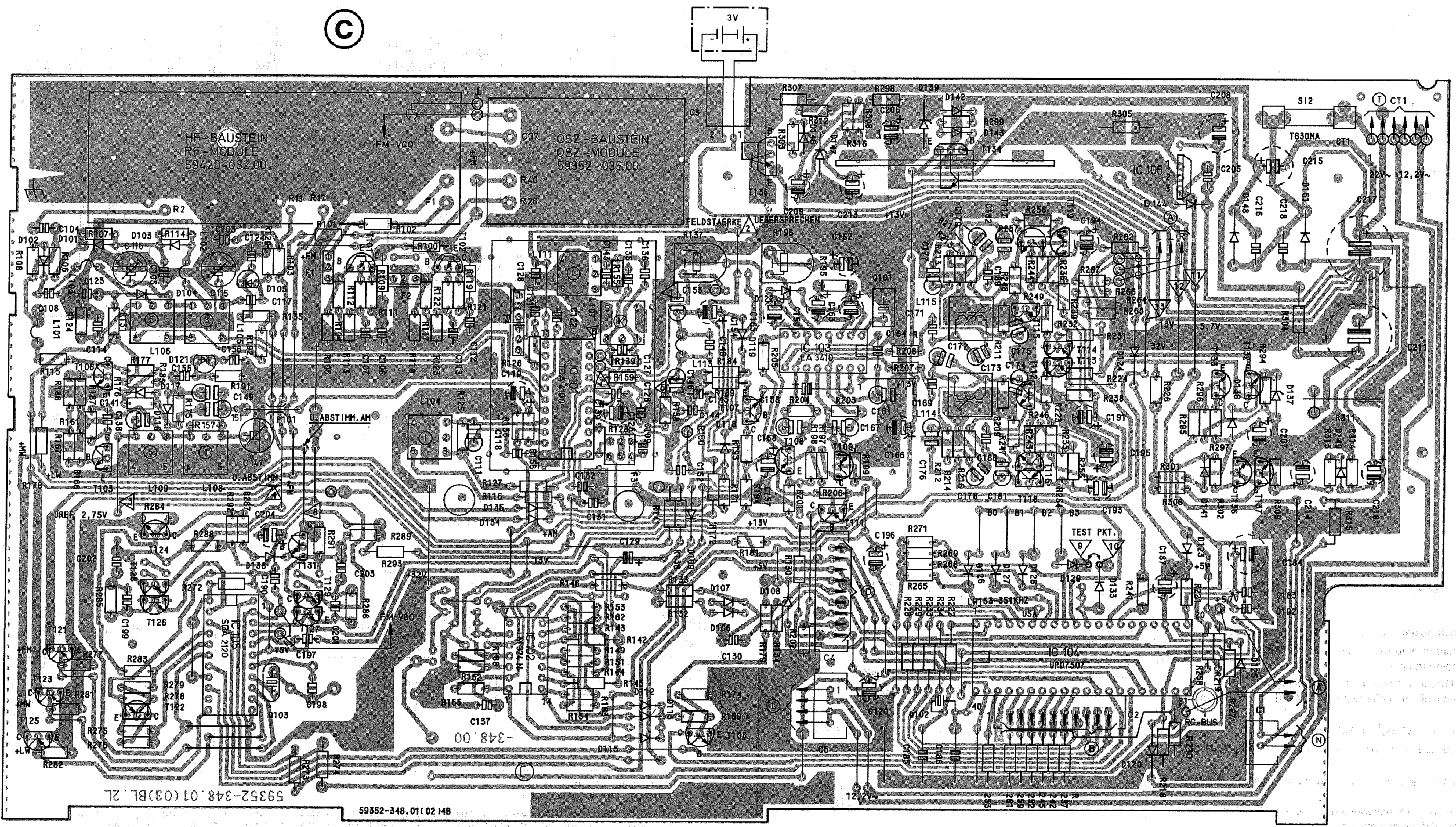

Faint, illegible text bleed-through from the reverse side of the page, appearing as ghostly impressions of a document.

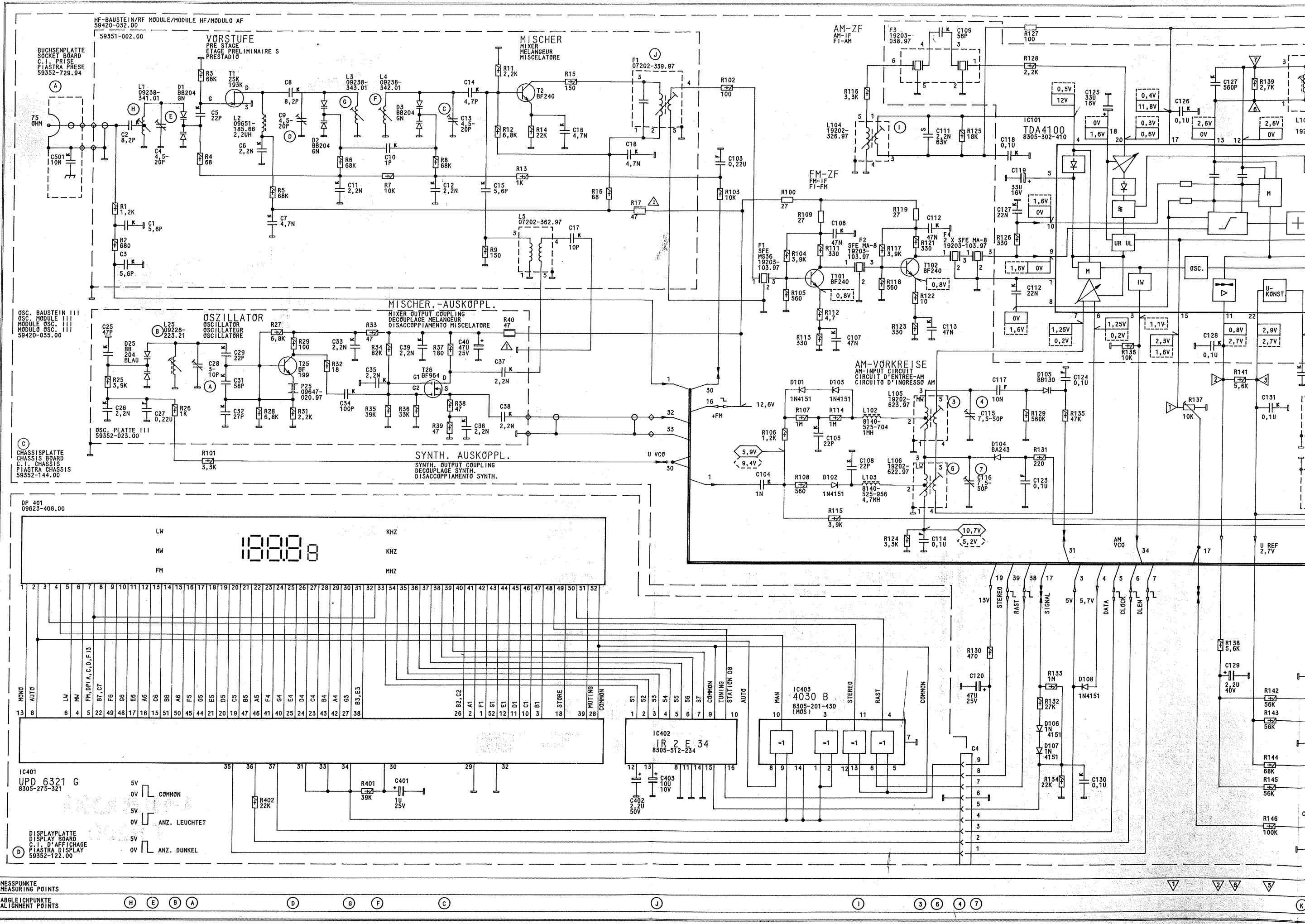

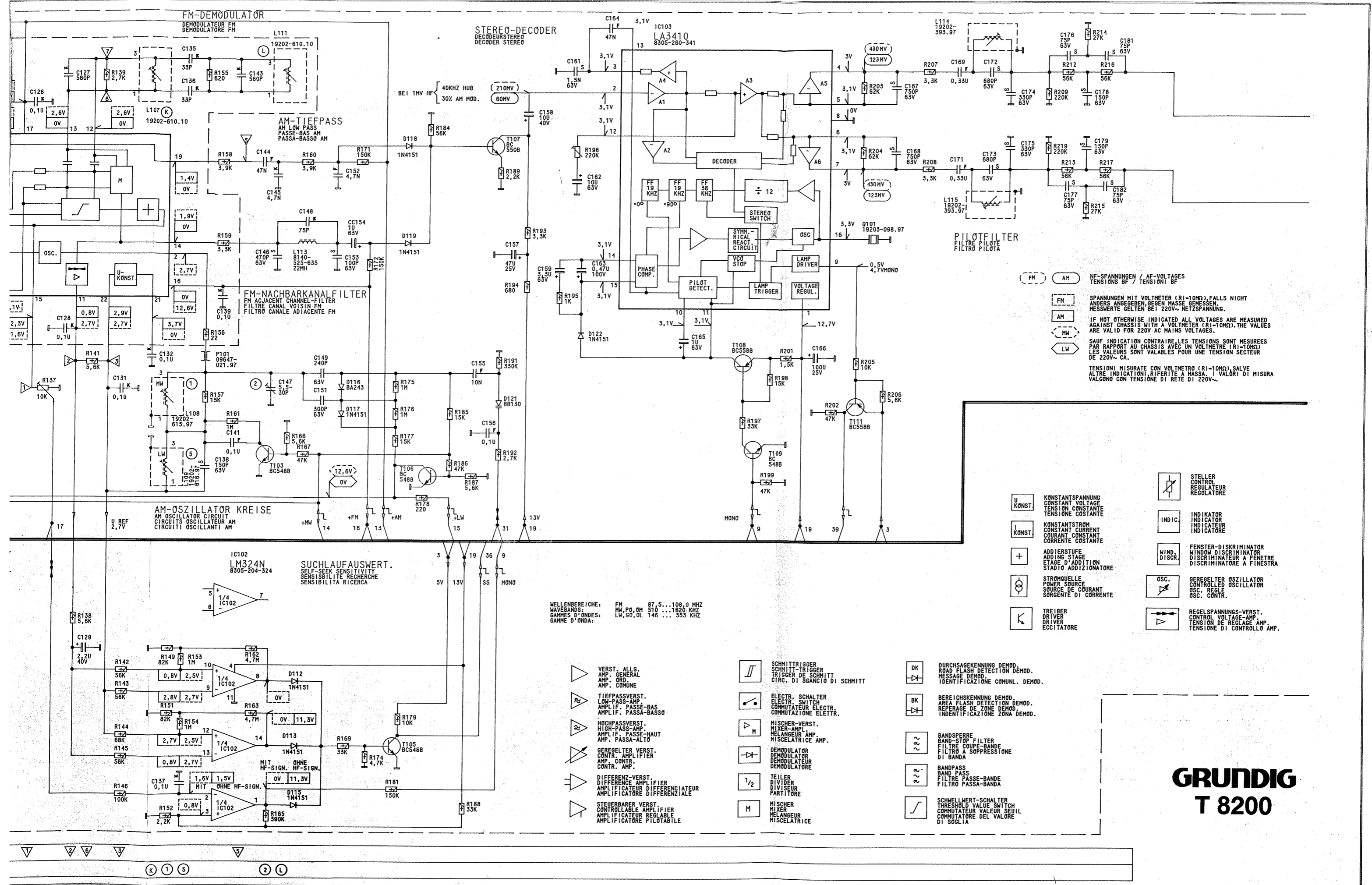

FM AM NF-SPANNUNGEN / AF-VOLTAGES
 TENSIONI BF / TENSIONI BF
 SPANNUNGEN MIT VOLTMETER (R1-10MΩ), FALLS NICHT
 ANDERS ANGEGEBEN, GEGEN MASSE GEMESSEN.
 MEßWERTE GELTEN BEI 220V~ NETZSPANNUNG.
 IF NOT OTHERWISE INDICATED ALL VOLTAGES ARE MEASURED
 AGAINST CHASSIS WITH A VOLTMETER (R1-10MΩ). THE VALUES
 ARE VALID FOR 220V AC MAINS VOLTAGES.
 SAUF INDICATION CONTRAIRE, LES TENSIONI SONT MESUREES
 PAR RAPPORT AU CHASSIS AVEC UN VOLTMETRE (R1-10MΩ).
 LES VALEURS SONT VALABLES POUR UNE TENSION SECTEUR
 DE 220V~ CA.
 TENSIONI MISURATE CON VOLTMETRO (R1-10MΩ), SALVE
 ALTRE INDICAZIONI, RIFERITE A MASSA. I VALORI DI MISURA
 VALGONO CON TENSIONE DI RETE DI 220V~.

- KONSTANTSPANNUNG
CONSTANT VOLTAGE
TENSION COSTANTE
- KONSTANTSTROM
CONSTANT CURRENT
CORRENTE COSTANTE
- ADDIERSTUFE
ADDING STAGE
ETAGE D'ADDITION
- STROMQUELLE
POWER SOURCE
SOURCE DE COURANT
- TREIBER
DRIVER
ECCITATORE
- STELLER
CONTROL
REGULATEUR
- INDIKATOR
INDICATOR
INDICATEUR
- FENSTER-DISKRIMINATOR
WINDOW DISCRIMINATOR
DISCRIMINATEUR A FENESTRA
- GEREGLER OSZILLATOR
CONTROLLED OSCILLATOR
OSC. CONTR.
- REGULIERBARE VERST.
CONTROL VOLTAGE-AMP
TENSION DE REGLAGE AMP.
- DURCHSAGEKENNUNG DEMOD.
ROAD FLASH DETECTION DEMOD.
MESSAGE DEMOD.
- BEREICHSKENNUNG DEMOD.
AREA FLASH DETECTION DEMOD.
IDENTIFICATION ZONE DEMOD.
- BANDSPERRE
BAND-STOP FILTER
FILTRE COUPE-BANDE
- BANDPASS
BAND PASS
FILTRE PASSE-BANDE
- SCHWELFWERT-SCHALTER
THRESHOLD VALUE SWITCH
COMBULATEUR VALEUR SEUIL

WELLENBEREICHE: FM 87,5...108,0 MHz
 MW, PO, OM 510...1620 KHz
 GAMME D'ONDES: LW, SO, OL 146...353 KHz

- VERST. ALLG.
AMP. GENERAL
AMP. ORD.
AMP. COMUNE
- TIEFPASSVERST.
LOW-PASS-AMP
AMPLIF. PASSE-BAS
AMPLIF. PASSA-BASSO
- HOCHPASSVERST.
HIGH-PASS-AMP
AMPLIF. PASSE-HAUT
AMPLIF. PASSA-ALTO
- GEREGLER VERST.
CONTR. AMPLIFIER
AMP. CONTR.
CONTR. AMP.
- DIFFERENZ-VERST.
DIFFERENCE AMPLIFIER
AMPLIFICATEUR DIFFERENCIEAU
AMPLIFICATEUR DIFFERENZIALE
- STEUERBARER VERST.
CONTROL VOLTAGE-AMP
AMPLIFICATEUR REGLABLE
AMPLIFICATEUR PILOTABILE
- SCHMITTRIGGER
SCHMITT-TRIGGER
TRIGGER DE SCHMITT
CIRC. DI SGANCIO DI SCHMITT
- ELECTR. SCHALTER
ELECTR. SWITCH
COMBULATEUR ELECTR.
COMBUTAZIONE ELETTA.
- MISCHER-VERST.
MIXER-AMPL.
MELANGEUR AMP.
MISCELATRICE AMP.
- DEMODULATOR
DEMODULATEUR
DEMODULATORE
- TEILER
DIVIDER
DIVISEUR
PARTITORE
- MISCHER
MIXER
MELANGEUR
MISCELATRICE
- DURCHSAGEKENNUNG DEMOD.
ROAD FLASH DETECTION DEMOD.
MESSAGE DEMOD.
- BEREICHSKENNUNG DEMOD.
AREA FLASH DETECTION DEMOD.
IDENTIFICATION ZONE DEMOD.
- BANDSPERRE
BAND-STOP FILTER
FILTRE COUPE-BANDE
- BANDPASS
BAND PASS
FILTRE PASSE-BANDE
- SCHWELFWERT-SCHALTER
THRESHOLD VALUE SWITCH
COMBULATEUR VALEUR SEUIL

GRUNDIG
T 8200

NF-VERSTÄRKER

AF-AMPLIFIER
AMPLIFICATEUR RF
AMPLIFICATORE RF

L - LINKER KANAL
LEFT CHANNEL
CANAL DE GAUCHE
CANALE SINISTRO

ZF-PROGRAMMIERUNG IF-PROGRAMMING

ZF MHZ	B3	B2	B1	B0
10,6000				
10,6125				I
10,6250			I	
10,6375			I	I
10,6500		I		
10,6625		I	I	
10,6750		I	I	I
10,6875		I	I	I
10,7000	I			
10,7125				
10,7250				
10,7375				
10,7500				
10,7625				
10,7750				
10,7875				

LCD-DISPLAY

09623-408.00 : GRUNDIG 09623-402.00 : BLAUPUNKT

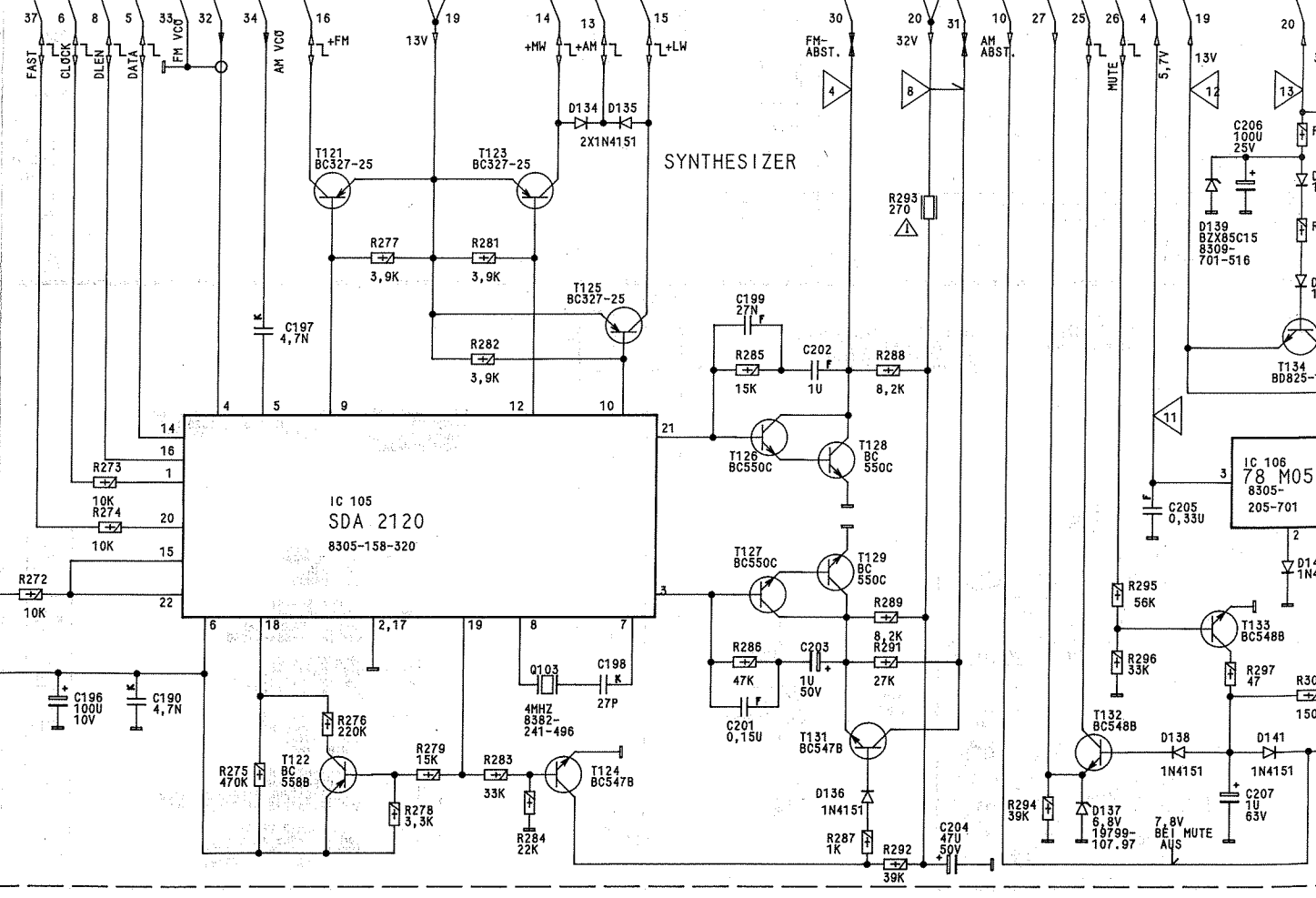
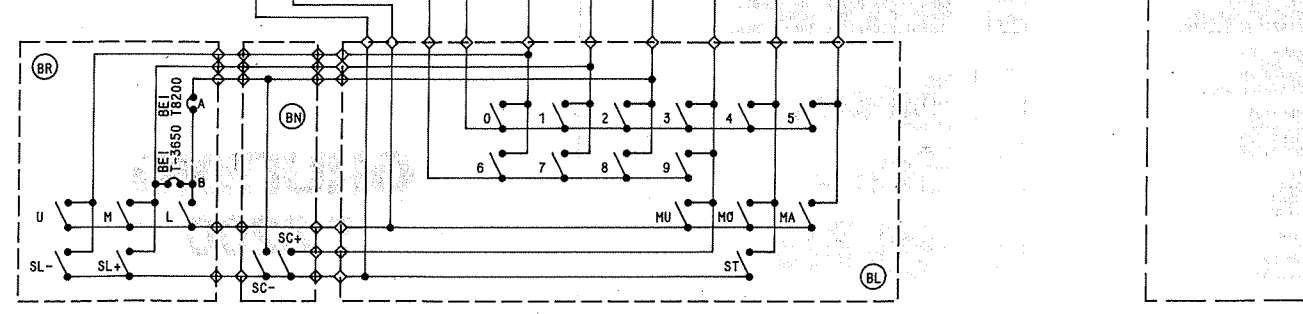
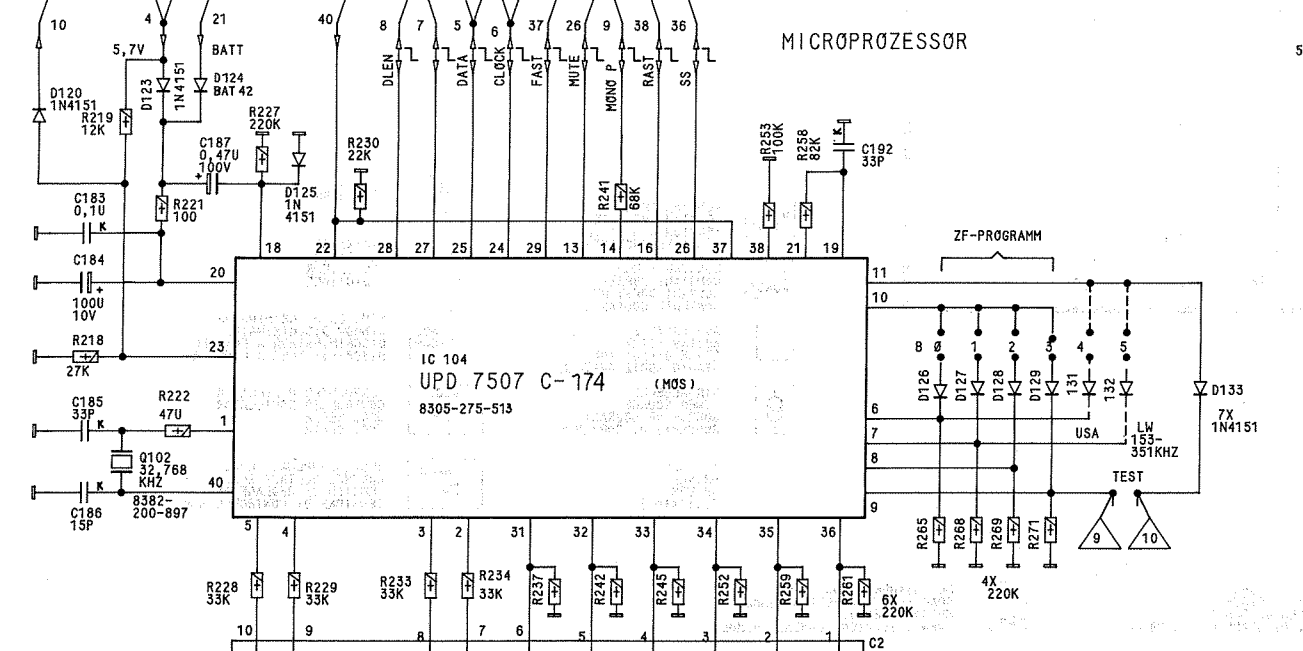
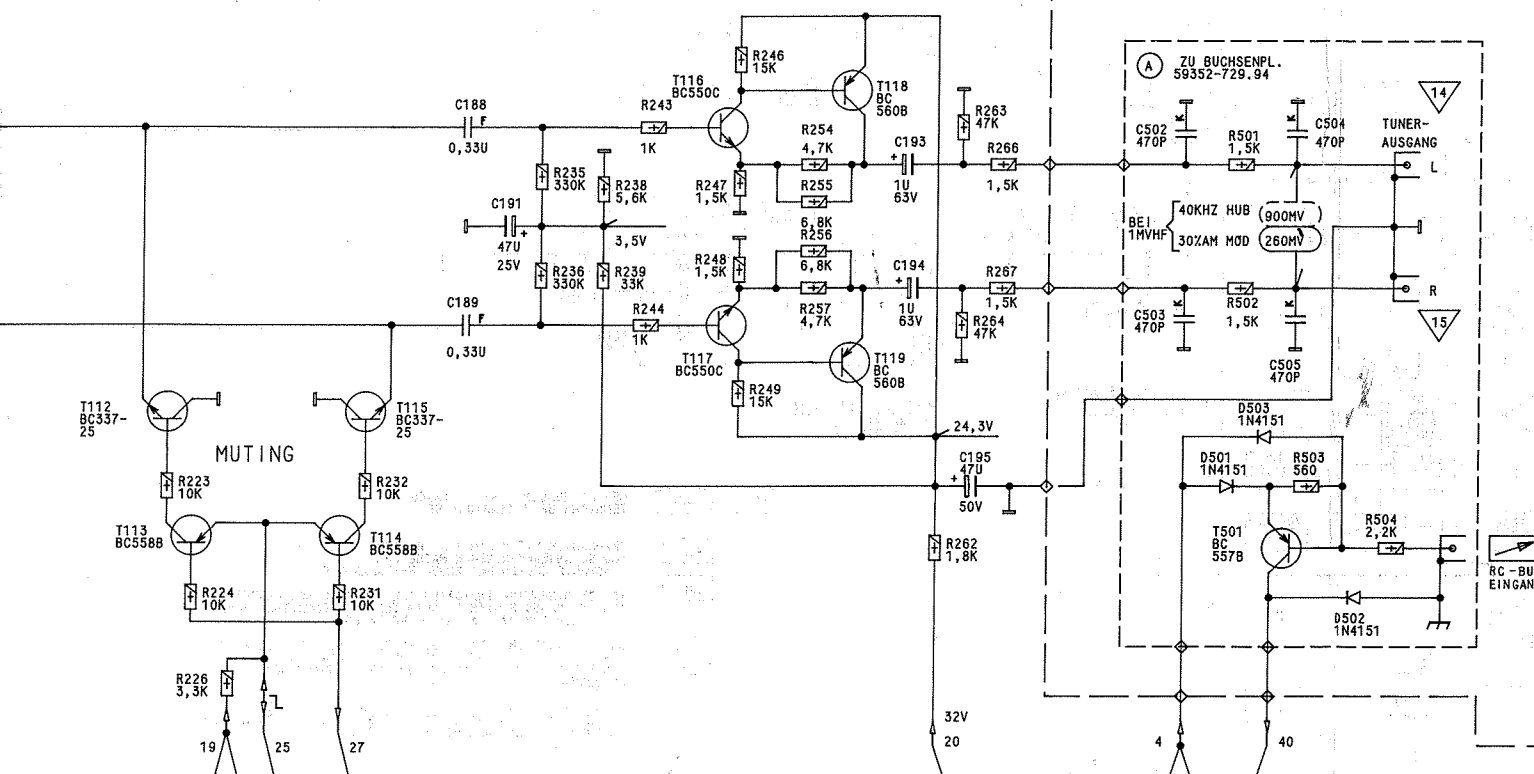
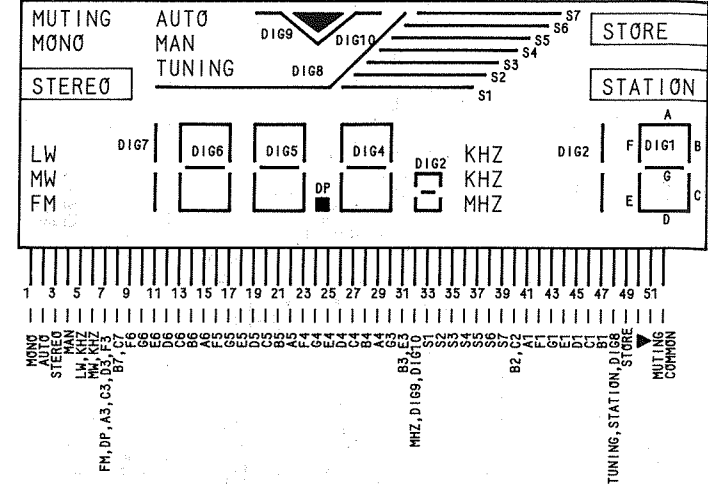

MESSPUNKTE
MEASURING POINTS
ABGLEICHPUNKTE
ALIGNMENT POINTS

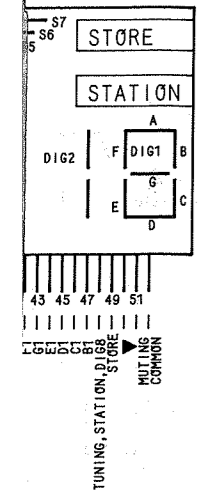

ANZEIGE MODUL
 STEREO-MODULIERTES HF-SIGNAL AN ANTENNENBUCHSE(1MV),GERAET ABSTIMMEN.
 TESTPUNKTE 9 ▽ ▽ 10 VERBINDEN.
 MAN-AUTO-TASTE DRUECKEN,ALLE SEGMENTE MUESSEN AUFLEUCHTEN

INDICATION MODULE
 STEREO-MODULATED HF SIGNAL TO AERIAL SOCKET(1MV),TUNE SET.
 CONNECT TEST POINTS 9 ▽ ▽ 10
 PRESS MAN/AUTO BUTTON,ALL SEGMENTS MUST LIGHT UP.

MODULE AFFICHAGE
 SIGNAL HF STEREO MODULE SUR PRISE ANTENNE(1MV),
 ACCORDER L'APPAREIL.
 RELIER POINTS DE TEST 9 ▽ ▽ 10
 ENFONCER TOUCHE MAN-AUTO,TOUS LES SEGMENTS DOIVENT S'ALLUMER.

MODULO D'INDICAZIONE
 SEGNALE AF A MODULAZIONE STEREO SULLA PRESA D'ANTENNA
 (1MV),TARARE L'APPARECCHIO.
 COLLEGARE I PUNTI DI CONTROLLO 9 ▽ ▽ 10
 PREMERE IL TASTO MAN-AUTO,DEVONO ACCENDERSI TUTTI I SEGMENTI.

⚠️ FUER DIE GERAETESICHERHEIT ABSOLUT NOTWENDIG UND ENTSPRECHEND DEN RICHTLINIEN DES VDE BZW. IEC. IM ERSATZFALL DUERFEN NUR BAUTEILE MIT GLEICHER SPEZIFIKATION VERWENDET WERDEN.

⚠️ ABSOLUTELY NECESSARY FOR THE SAFETY OF THE SET. THESE COMPONENTS MEET THE SAFETY REQUIREMENTS ACCORDING TO VDE OR IEC. RESP. AND MUST BE REPLACED BY PARTS OF SAME SPECIFICATION ONLY.

⚠️ ABSOLUMENT NECESSAIRE POUR LA SECURITE DE L'APPAREIL ET CONFORME AUX REGULATIONS VDE ET IEC. EN CAS DE REMPLACEMENT. N'UTILISER QUE DES COMPOSANTS AVEC LES MEMES SPECIFICATIONS.

⚠️ NECESSARI PER LA SICUREZZA DELL' APPARECCHIO E SONO CONFORMI ALLE NORME DI SICUREZZA VDE E IEC. IN CASA DI SOSTITUZIONE IMPIEGARE QUINDI SOLTANTO PEZZI IN RICAMBIO ORIGINALI.

- WIDERSTAND/RESISTOR - RESISTANCE/RESISTENZA**
- KSW 0204 DIN
 - HSW 0204 DIN
 - KSW 0207 DIN
 - HSW 0207 DIN
 - KSW 0309 DIN
 - KSW 0411 DIN
 - KSW 0617 DIN
 - HSW 0309 DIN
 - NTC
- KONDENSATOR/CAPACITOR - CONDENSATEUR/CONDENSATORE**
- ± ELKO ELECTROLYTIC / ELECTROLYTIC / ELETTROLITICO
 - ± TANTAL ELKO TANTALUM ELECTROLYTIC / ELECTROLYTIC AU TANTALE / ELETTROLITICO AL TANTALIO
 - FOLIE FOIL / A FEUILLE / A FOGLIA
 - KERAMIK CERAMIC / CERAMIQUE / A CERAMICA
 - GLIMMER MICA / AU MICA / A MICA
 - VIELSCHICHT MULTILAYER / A COUCHES MULTIPLES / A PIU' STRATI
 - POLYPROPYLEN (KS-KP)

ÄNDERUNGEN VORBEHALTEN
 SUBJECT TO ALTERATION
 MODIFICATIONS RESERVEES
 CON RISERVA DI MODIFICA

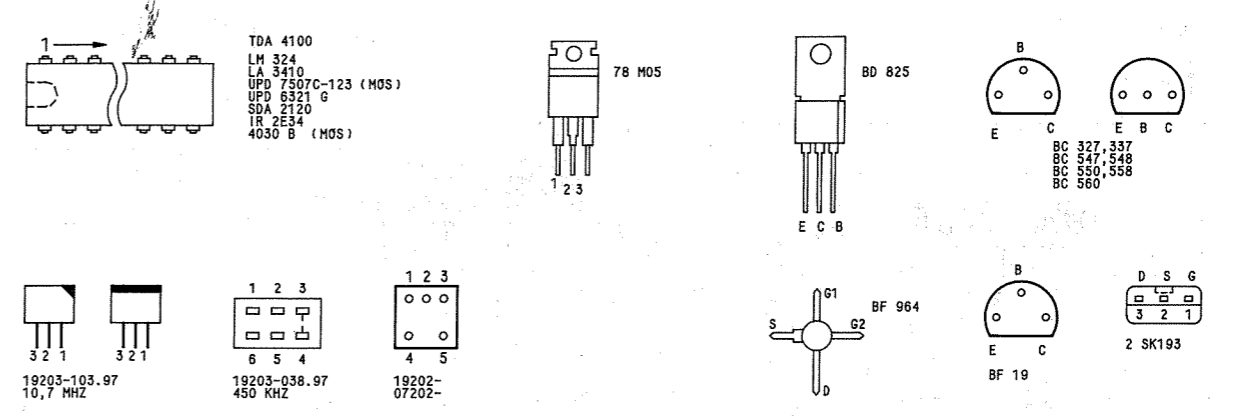

- GLEICHSPANNUNG DC-VOLTAGE / TENSION CONTINUE / TENSION CONTINUA
- WECHSELSPANNUNG AC-VOLTAGE / TENSION ALTERNATIVE / TENSIONE ALTERNATA
- REGENSPANNUNG CONTROL VOLTAGE / TENSION DE REGLAGE / TENSIONE DI CONTROLLO
- ABSTIMMSpannung TUNING VOLTAGE / TENSION DE SYNTONISATION / TENSIONE DI SINTONIA
- SCHALTSPANNUNG SWITCHING VOLTAGE / TENSION DE COMMUTATION / TENSIONE DI COMMUTAZIONE

ACHTUNG!
 VORSCHRIFTEN BEIM UMGANG MIT MOS-BAUTEILEN BEACHTEN!
 ATTENTION!
 OBSERVE MOS COMPONENTS HANDLING INSTRUCTIONS WHEN SERVICING!
 ATTENTION!
 LORS DE LA MANIPULATION DES CIRCUITS MOS, RESPECTER LES PRESCRIPTIONS MOS!
 ATTENZIONE!
 OSSERVARE LE RELATIVE PRESCRIZIONI DURANTE I LAVORI CON COMPONENTI MOS!

- | | | |
|---|--------------------------------------|---|
| SW-SCHWARZ
BLACK
NOIR
NERO | BN-BRAUN
BROWN
BRUN
MARRONE | RT-ROT
RED
ROUGE
ROSSO |
| GE-GELB
YELLOW
JAUNE
GIALLO | GN-GRUEN
GREEN
VERT
VERDE | BL-BLAU
BLUE
BLEU
BLU |
| VI-VIOLETT
VIOLET
VIOLET
VIOLETTIO | GR-GRAU
GREY
GRIS
GRIGIO | WS-WEISS
WHITE
BLANC
BIANCO |
| RS-ROSA
PINK
ROSE
ROSA | OR-ORANGE
ORANGE
ARANCIONE | TR-TRANSPARENT
TRANSPARENT
TRANSPARENT
TRASPARENTE |

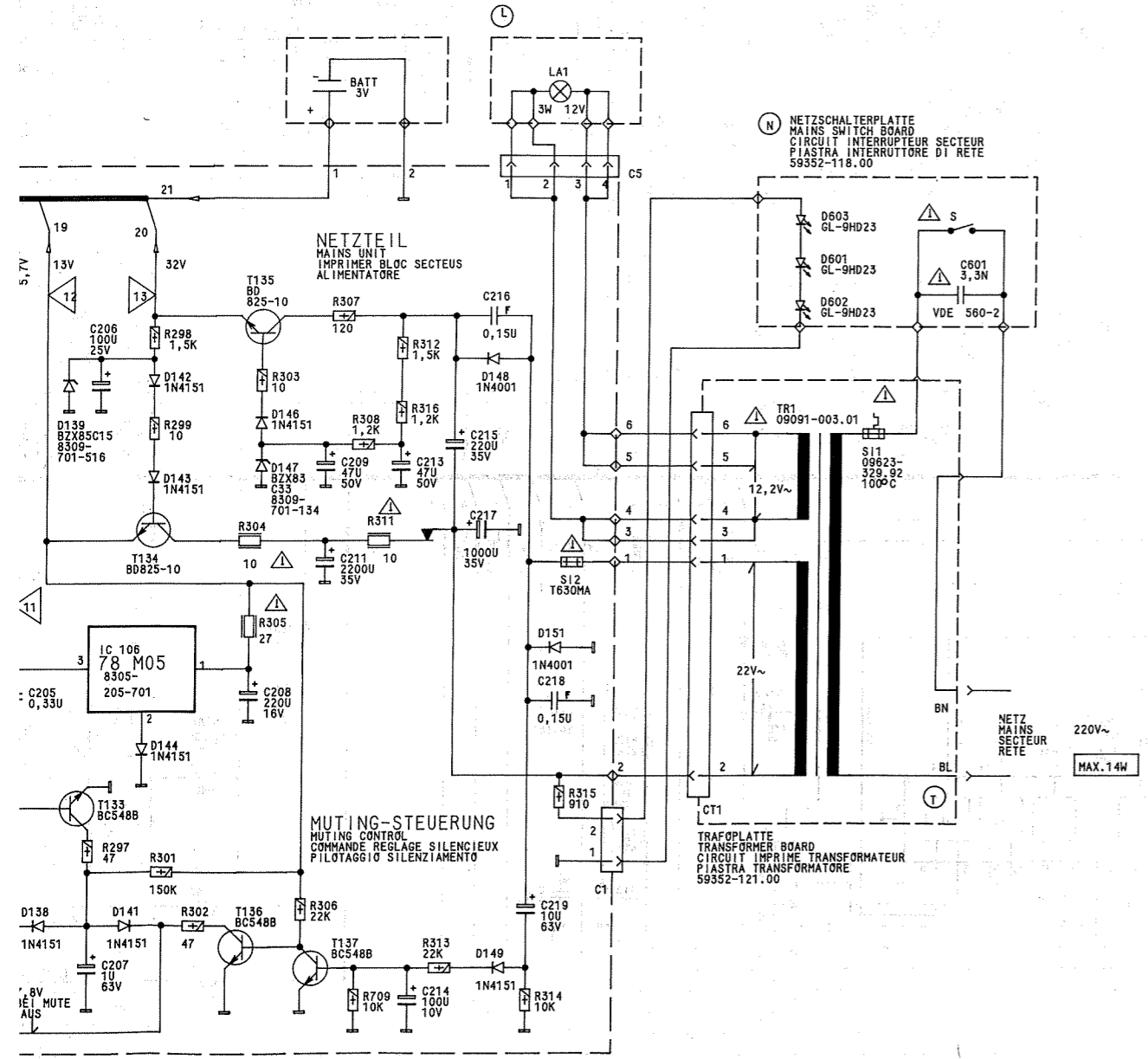

GRUNDIG
T 8200