

Platinenabbildungen und Schaltpläne / Layout of the PCB and Circuit Diagrams

Bauteilhinweise / Note on Components

SPANNUNGEN MIT VOLTMETER (RI=10 MOHM). FALLS NICHT ANDERS ANGEGEBEN, GEGEN MASSE GEMESSEN. MESSWERTE GELTEN BEI 220V- NETZSPANNUNG.

IF NOT OTHERWISE INDICATED ALL VOLTAGES ARE MEASURED AGAINST CHASSIS WITH A VOLTMETER(RI=10 MOHM). THE VALUES ARE VALID FOR 220V AC MAINS VOLTAGES.

SAUF INDICATION CONTRAIRE, LES TENSIONS SONT MESUREES PAR RAPPORT AU CHASSIS AVEC UN VOLTMETRE (RI=10 MOHM). LES VALEURS SONT VALIDES POUR UNE TENSION SECTEUR DE 220V CA.

TENSIONI MISURATE CON VOLTMETRO (RI=10 MOHM), SALVE ALTRE INDICAZIONI, RIFERITE A MASSA I VALORI DI MISURA VALGONO CON TENSIONE DI RETE DI 220V.

LAS TENSIONES, SIEMPRE QUE NO SE INDIQUE OTRA COSA, SE MIDEN CON RESPECTO A MASA CON VOLTMETRO (RI=10 MOHM). LOS VALORES DE MEDIDA SON VALIDOS CON 220V DE TENSION DE RED.

ACHTUNG ! VORSCHRIFTEN BEIM UMGANG MIT MOS BAUTEILEN BEACHTEN.

ATTENTION ! OBSERVE MOS COMPONENTS HANDLING INSTRUCTIONS WHEN SERVICING.

ATTENTION ! LORS LA MANIPULATION DES CIRCUITS MOS, RESPECTER LES PRESCRIPTIONS MOS.

ATTENZIONE ! OSSERVARE LE RELATIVE PRESCRIZIONI DURANTE I LAVORI CON COMPONENTI MOS.

ATENCIÓN ! RESPETAR EL TRATAMIENTO DE COMPONENTS MOS.

FUER DIE GERAETESICHERHEIT ABSOLUT ERFORDERLICH UND ENTSPRECHEND DEN RICHTLINIEN DES VDE BZW. IEC, IM ERSATZFALL DUERFEN NUR BAUTEILE MIT GLEICHER SPEZIFIKATION VERWENDET WERDEN.

ABSOLUTELY NECESSARY FOR THE SAFETY OF THE SET, THESE COMPONENTS MEET THE SAFETY REQUIREMENT ACCORDING TO VDE OR IEC. MUST BE REPLACED BY PARTS OF SAME SPECIFICATION ONLY.

ABSOLUMENT NECESSAIRE POUR LA SECURITE DE L'APPAREIL ET CONFORME AUX REGULATIONS VDE ET IEC, EN CAS DE REMPLACEMENT UTILISER QUE DE COMPOSANTS AVEC LES MEMES SPECIFICATION.

NECESSARI PER LA SICUREZZA DELL' APPARECCHIO E SONO CONFORMI ALLE NORME DI SICUREZZA VDE E IEC, IN CASO DI SOSTITUZIONE IMPIEGARE QUINDI SOLTANTO PEZZI IN RICAMBO ORIGINALI.

ABSOLUTAMENTE NECESARIO PARA LA SEGURIDA DEL APARATO Y DE ACUERDO CON LAS NORMAS DE SEGURIDAD VDE O IEC, EN CASO DE SUSTITUCION SOLO DEBEN EMPLEARSE COMPONENTS CON LA MISMA ESPECIFICACION.

VON OBEN GESEHEN
TOP VIEW
VUE DE HAUT
VISTA DA SOPRA
VISTO DESDE ARRIBA

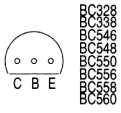

- BC328
- BC338
- BC348
- BC358
- BC550
- BC556
- BC558
- BC560

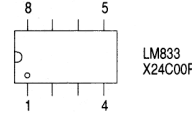

LM833
X24C00P

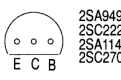

- 2SA949
- 2SC2229
- 2SA1145
- 2SC2705

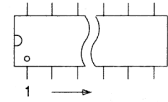

AN7062P
LC4966
LC7821
M68HC05-02

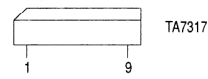

TA7317

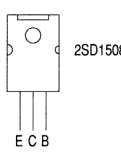

2SD1508

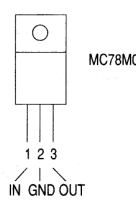

MC78M05

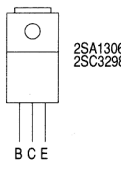

2SA1306
2SC3298

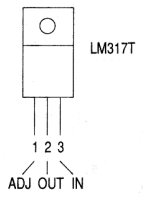

LM317T

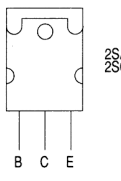

2SA1265N
2SC3182N

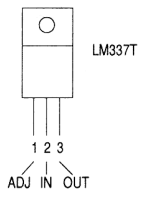

LM337T



NF-SPANNUNGEN BEI 2 x 8W AN 8 OHM = 8V ~ AM AUSGANG, 1KHZ, LAUTSTAERKE VOLL AUF, DEFEAT EIN, BALANCE MITTE, LAUTSPRECHERRELAIS EIN.

AF VOLTAGES AT 2 x 8W INTO 8 OHM = 8V ~ AT OUTPUT, 1KHZ, VOLUME FULLY UP, DEFEAT ON, BALANCE IN CENTRE SETTING, LOUDSPEAKER SWITCHES ON.

TENSIONS BF POUR 2 x 8W SUR 8 OHM = 8V ~ A LA SORTIE, 1KHZ, VOLUME AU MAXIMUM, DEFEAT EN SERVICE, REGLAGES DE BALANCE EN POSITION MEDIANE, COMMUTATEUR HAUT-PARLEURS EN SERVICE.

TENSIONI BF ALL' USCITA CON 2 x 8W E 8 OHM = 8V ~ 1KHZ, VOLUME AL MASSIMO, DEFEAT INSERITO, REGOLATORI DI BILANCIAMENTO AL CENTRO, COMMUTATORI DEGLI ALTOPARLANTI INSERITI.

BK= SCHWARZ BLACK NERO NOIR NEGRO YE= GELB YELLOW JAUNE GIALLO AMARILLO VT= VIOLETT VIOLET VIOLETT VIOLETA RS= ROSA PINK ROSE	BN= BRAUN BROWN BRUN MARRONE MARRON GN= GRUEN GREEN VERT VERDE GY= GRAU GREY GRIS GRIGIO OR= ORANGE ARANCIONE NARANJA	RD= ROT RED ROUGE ROSSO ROJO BU= BLAU BLUE BLEU BLU AZUL WH= WEISS WHITE BLANC BIANCO BLANCO NF= NATURFARBEN NATURAL COLOR COULEUR NATURELLE COLORI NATURALRE COLOR NATURAL
---	--	--

KONDENSATOR/CAPACITOR
CONDENSATEUR/CONDENSATORE/CONDENSADOR

- ELKO
ELECTROLYTIC
ELECTROLYTIQUE
ELETTROLITICO
ELECTROLITICO
- TANTAL
TANTALUM ELEC.
ELEC. AU TANTALE
ELET. AL TANTALICO
ELEC. DE TANTALO
- FOLIE
FOIL
A FEUILLE
A FOGLIA
DELAMINA
- KERAMIK
CERAMIC
CERAMIQUE
A CERAMICA
CERAMICO
- GLUMMER
MICA
AU MICA
A MICA
DE MICA
- VIELSCHICHT
MULTILAYER
A COUCHES MULTIPLES
A PILI STRATI
MULTICAPA
- POLYPROPYLEN
DE POLIPROPILENO
(KS-KP)
- BIPOLAR

WIDERSTAND/RESISTOR
RESISTANCE/RESISTENCIA

- DRAHT
WIRE
BOBINE
A FILO
- METALLOXYDSCHICHT
METAL OXIDE
A OXYDE METALLIQUE
AD OSSIDO METALICO
- RAUSCHARM
LOW NOISE
A SOUFFLE REDUIT
A BASSO RUMORE
- SCHWER ENTLAMMBAR
LOW FLAMMABILITY
PEU INFLAMMABLE
A BASSA INFLAMMABILITA
- SICHERUNGSWIDERSTAND
SAFETY RESISTOR
FUSIBLE
DI SICUREZZA

ÄNDERUNGEN VORBEHALTEN
SUBJECT TO ALTERATION
SOUS RESERVE DE MODIFIC
CON RISERVA DI MODIFICA
RES. EL DERECHO DE MODIFIC.

**Schaltbild / Circuit Diagram: -Bedienplatte / Operation Board
-Schalterplatte / Switch Board
-Lautstärke-LED-Platte / Volume-LED Board**

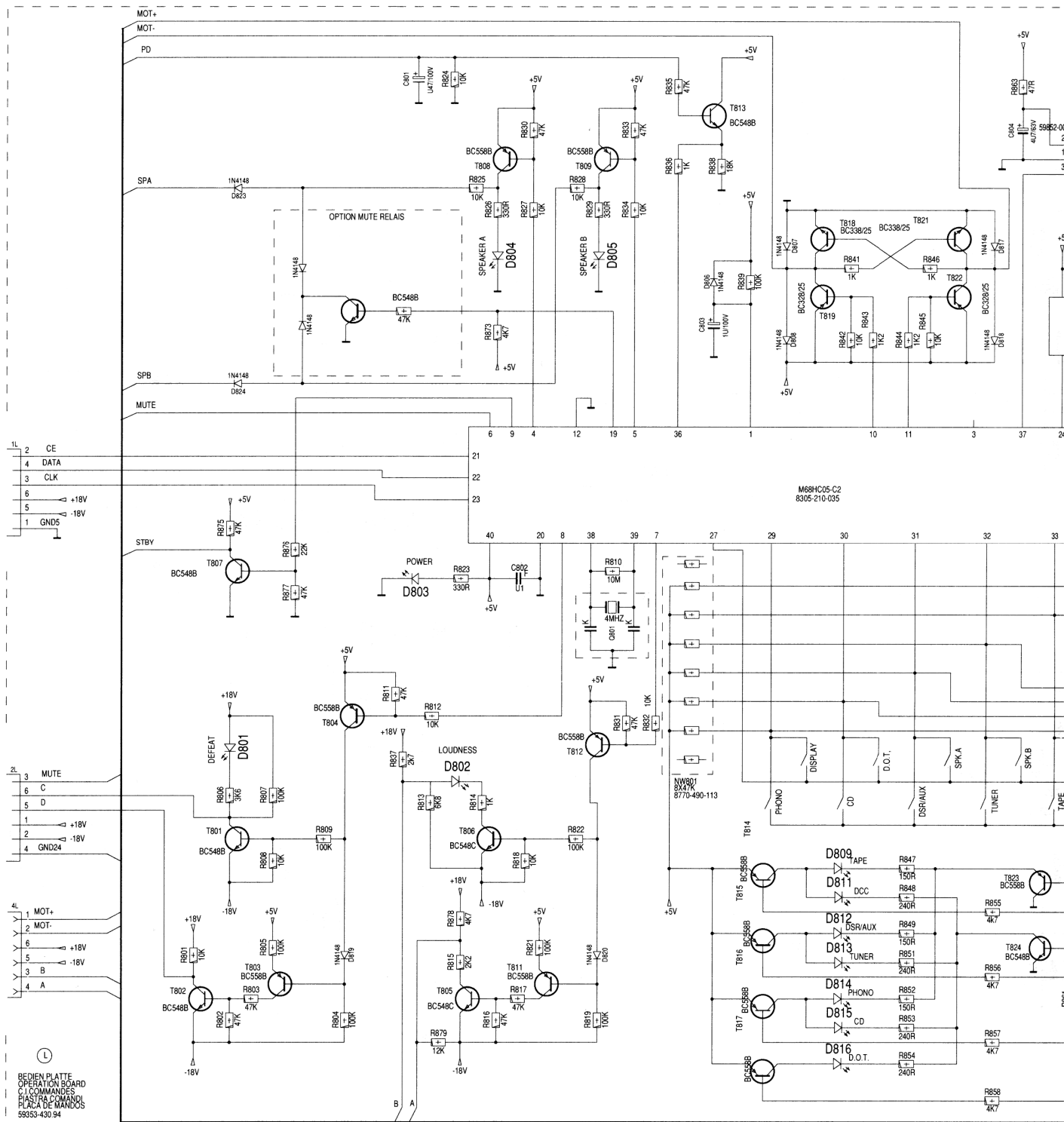

1L
2 CE
3 DATA
4 CLK
5
6 +18V
7
8 -18V
9 GND5

EINGANGSWÄHLER-PLATTE
INPUT BOARD
CLIENTREE
PIASTRA INGR
PLACA DEL ENT.

2H
3 MUTE
4 C
5 D
6
7 +18V
8 -18V
9 GND24

KLANGREGLER PLATTE
TONE CONTROL BOARD
C.I. REGI DE TONALITE
PIASTRA REG. DI TONALITE
PLACA REG. SONIDO

4G
1 MOT+
2 MOT-
3
4 +18V
5 -18V
6 A
7 B

LAUTSTÄRKE REGLER PLATTE
VOLUME BOARD
C.I. SONORE
PIASTRA VOLUME
PLACA VOLUMEN

Ⓛ
BEDIEN PLATTE
OPERATION BOARD
C.I. COMMANDES
PIASTRA COMANDI
PLACA DE MANDOS
59353-430 94

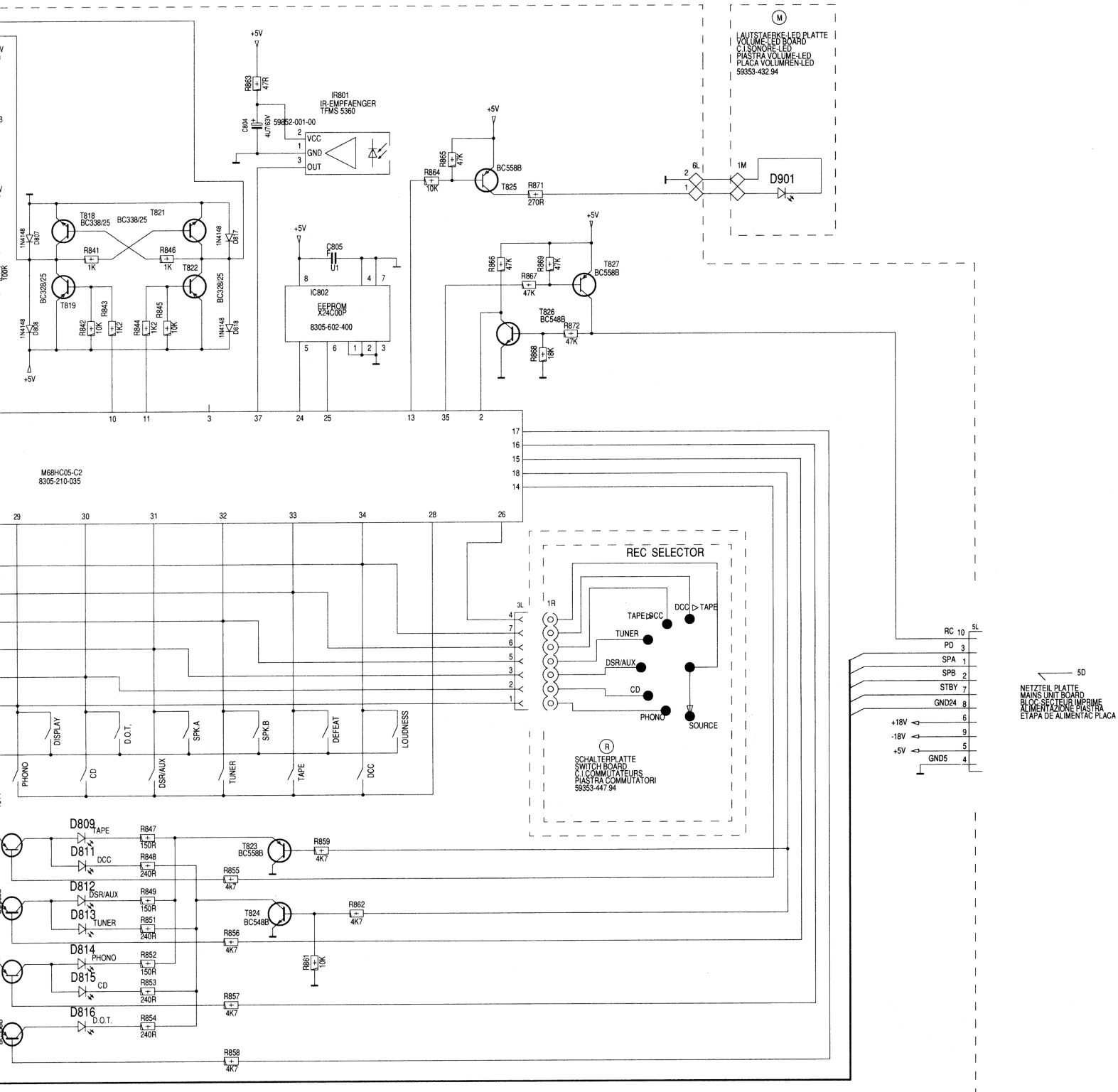

50
 NEZTEL-PLATTE
 MAINS UNIT BOARD
 BLOC SECTEUR IMPRIME
 ALIMENTAZIONE PIASTRA
 ETAPA DE ALIMENTAC PLACA

Schaltbild Klangreglerplatte / Circuit Diagram Tone Control Board

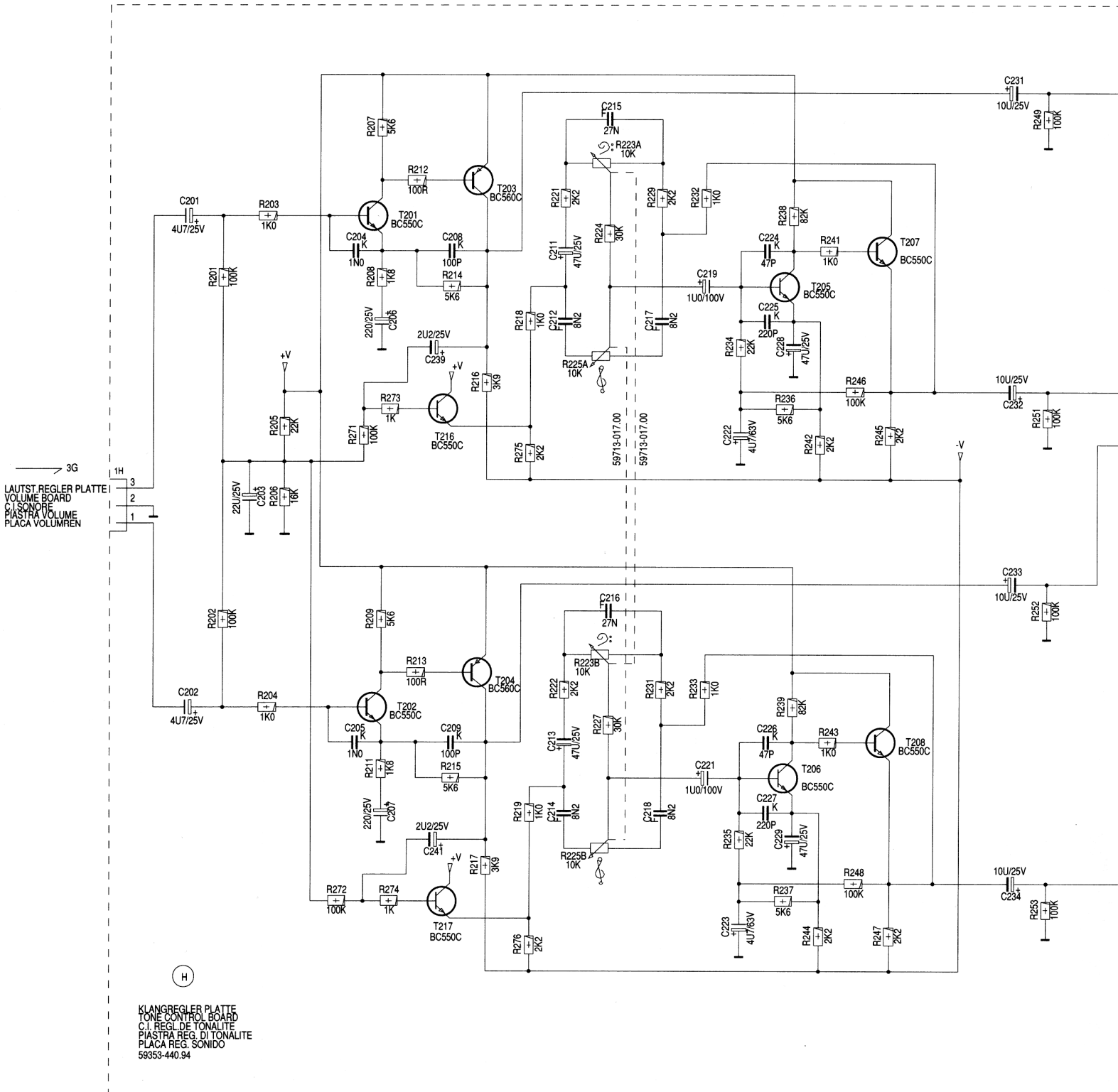

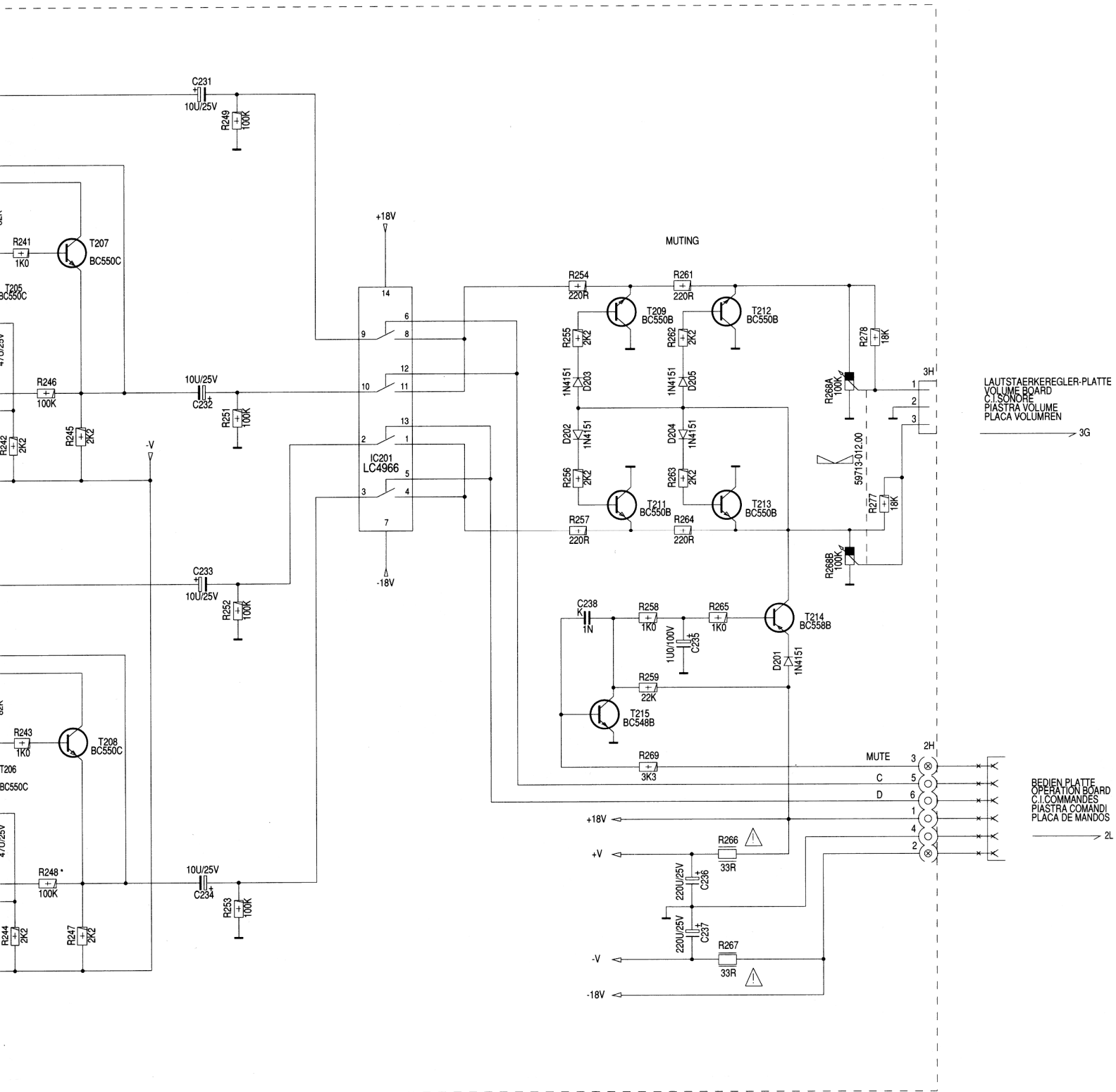

Eingangswählerplatte / Input Board

Ansicht von der Bestückungsseite / View of components side

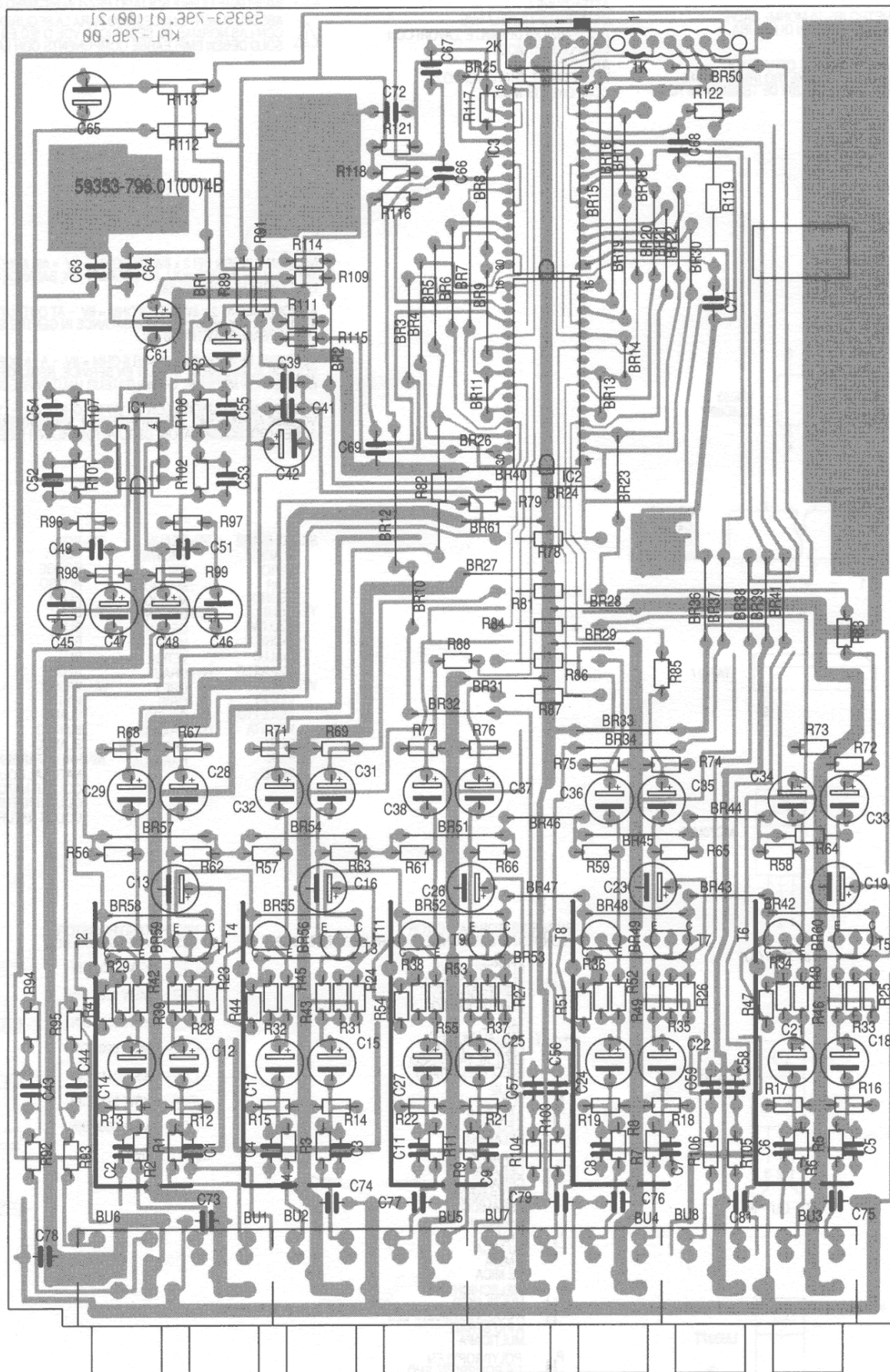

Schaltbild Eingangswählerplatte / Circuit Diagram Input Board

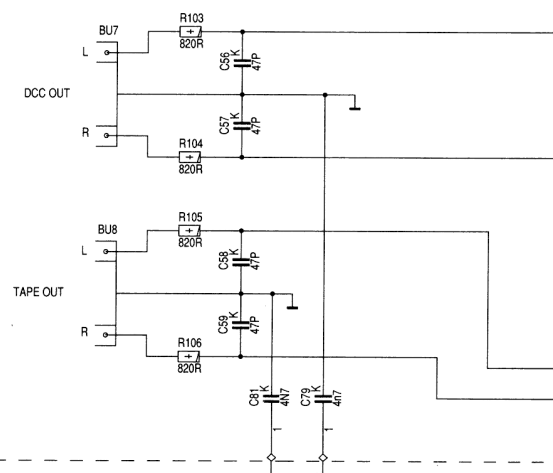
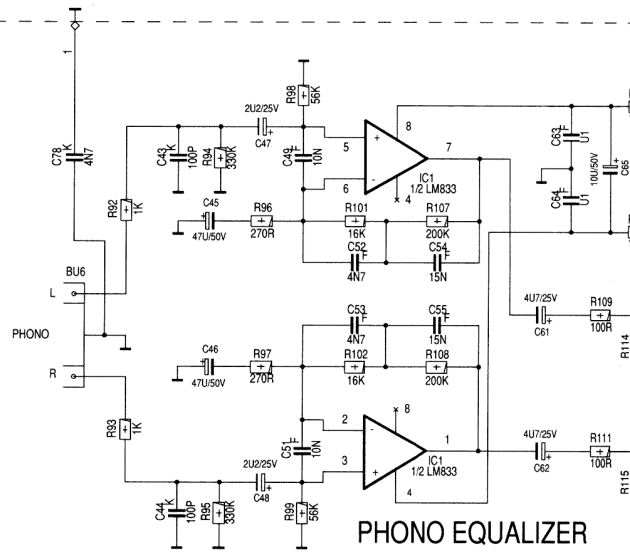
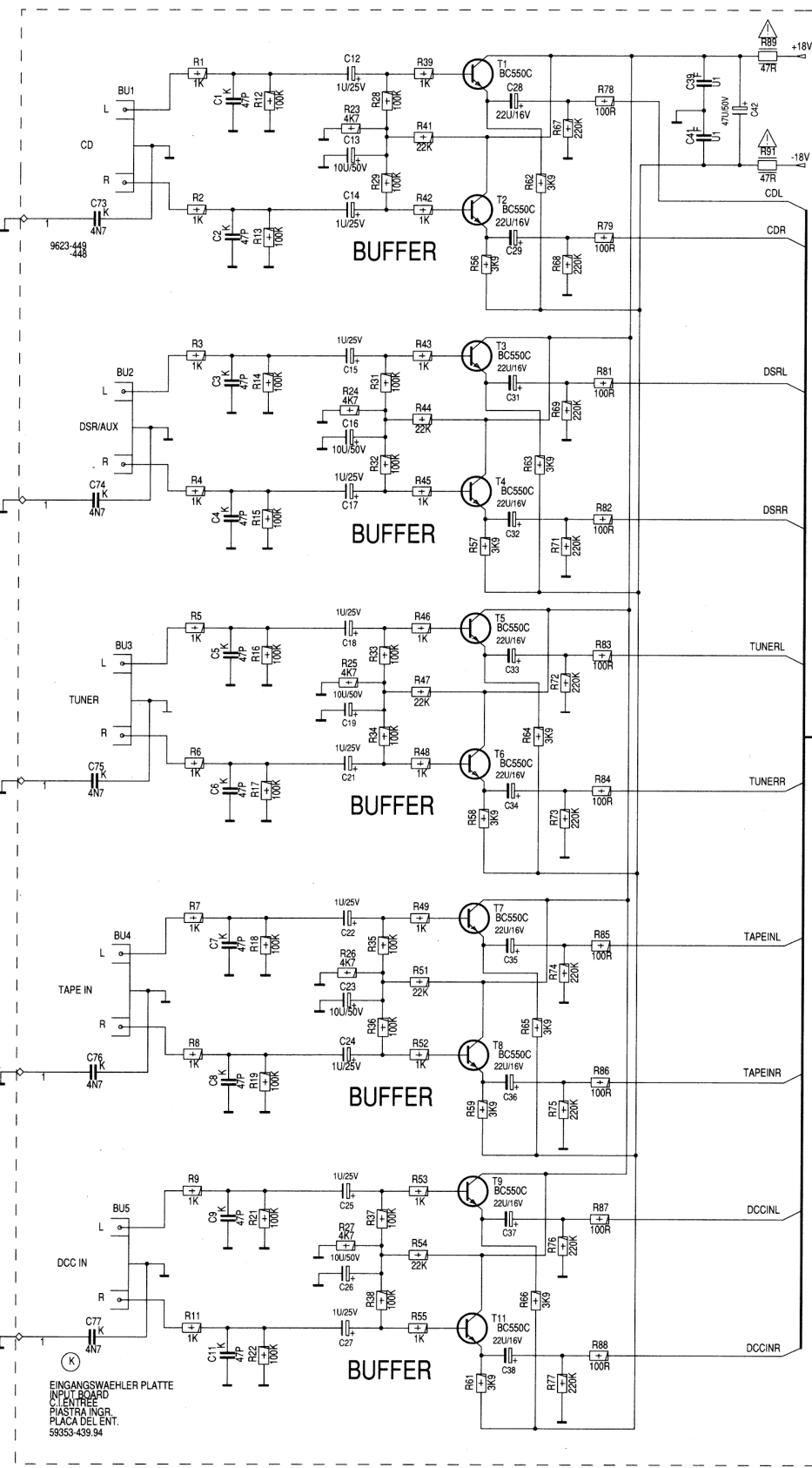

INGANGSWAEHLER PLATTE
INPUT BOARD
PIASTRA INGR.
PLACA DEL ENT.
58353-439.94

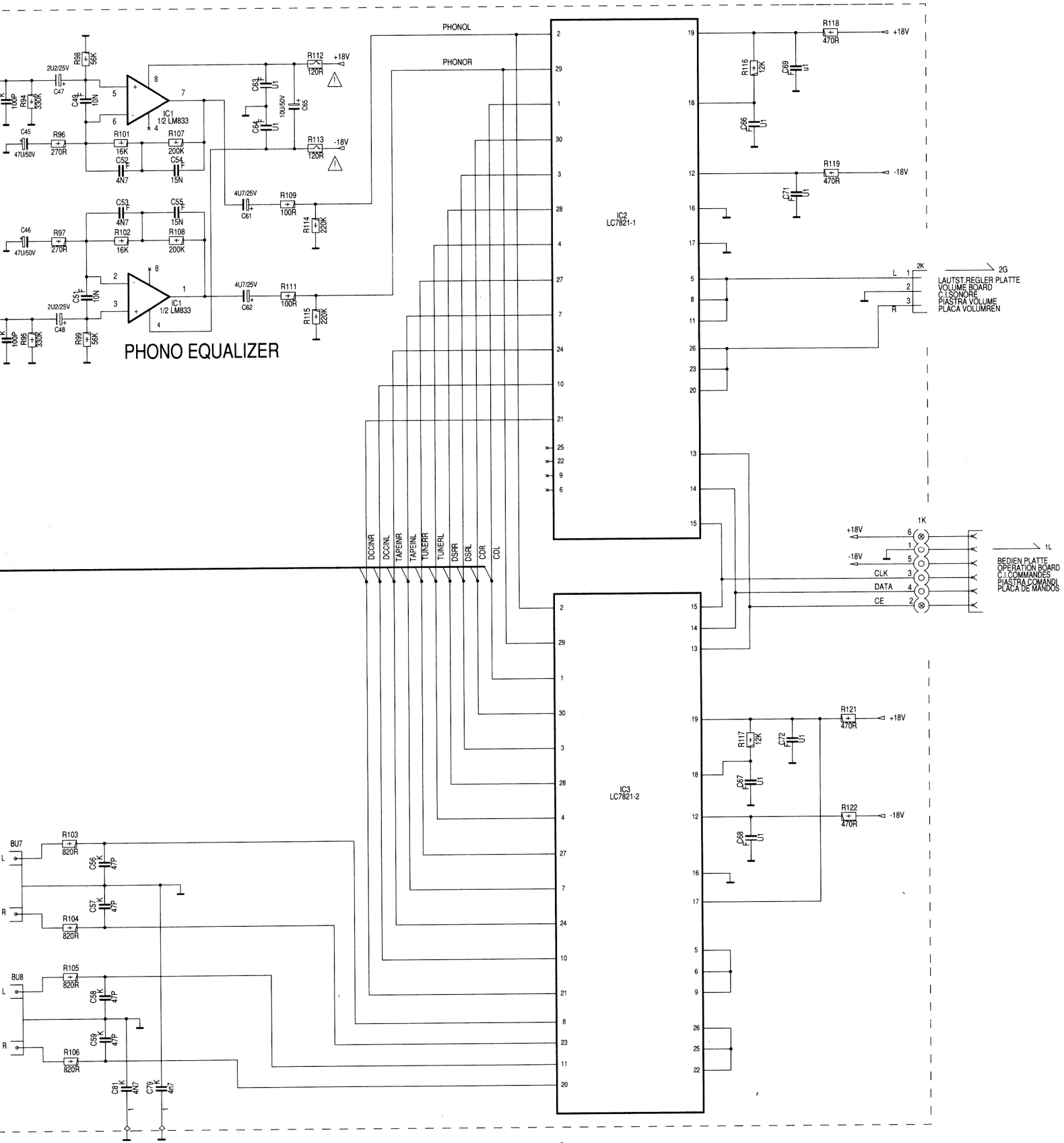

Lautstärkereglerplatte / Volume Board

Ansicht von der Bestückungsseite / View of components side

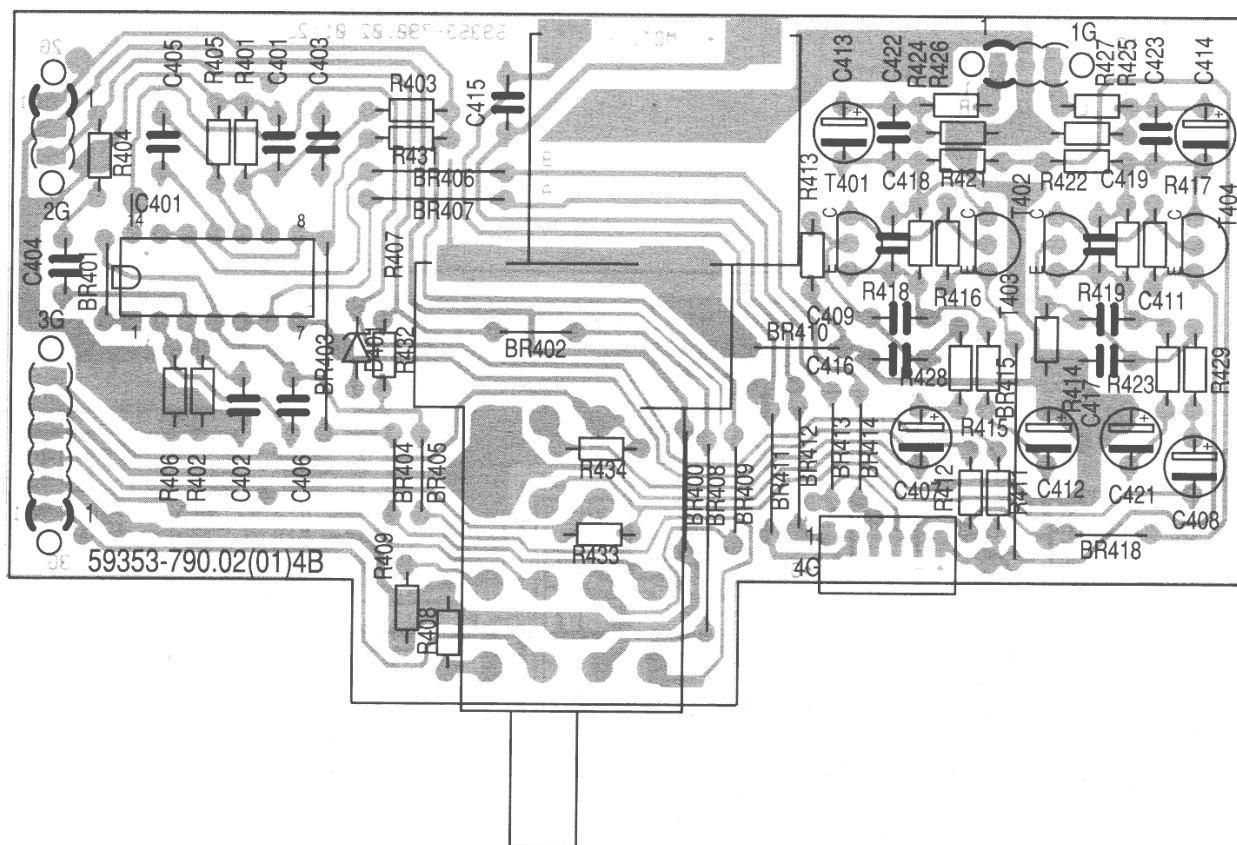

Ansicht von der Lötseite / View of solder side

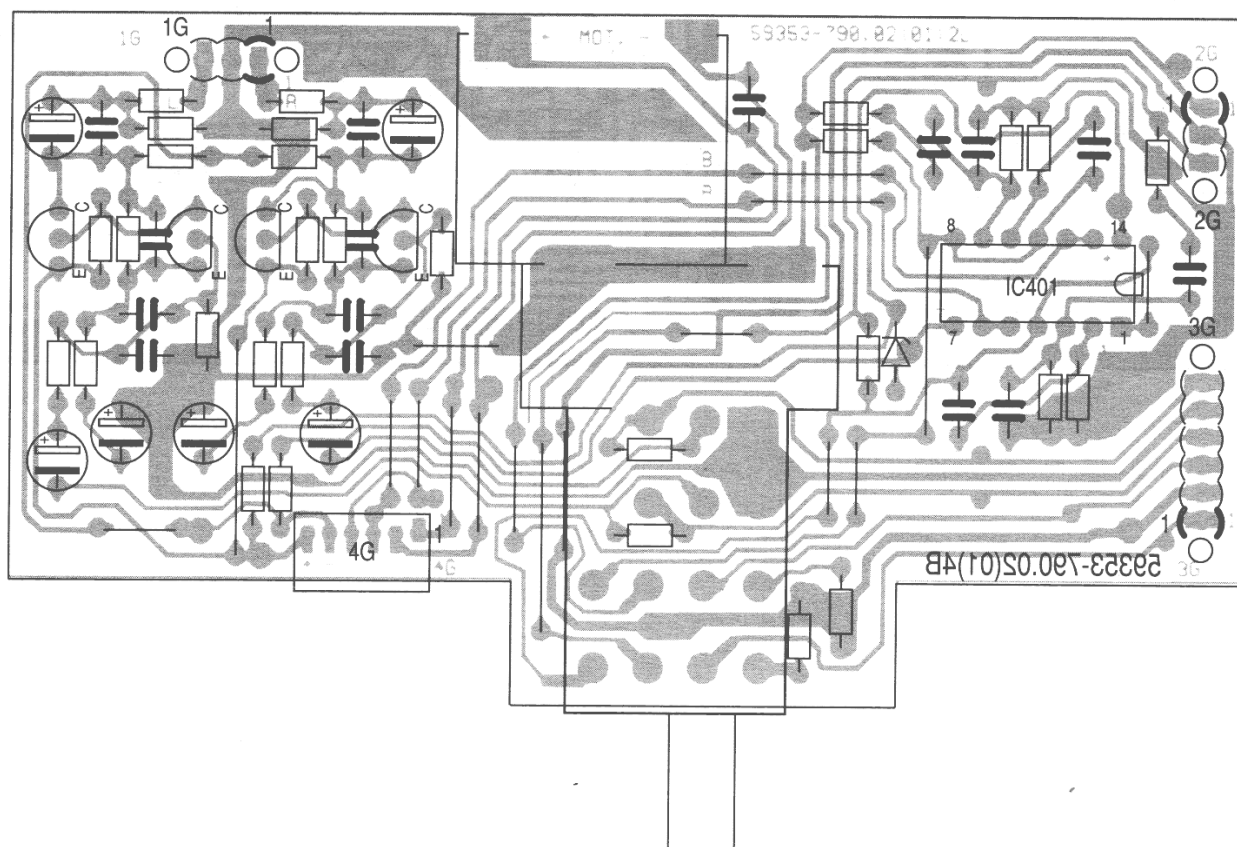

Klangreglerplatte / Tone Control Board

Ansicht von der Bestückungsseite / View of components side

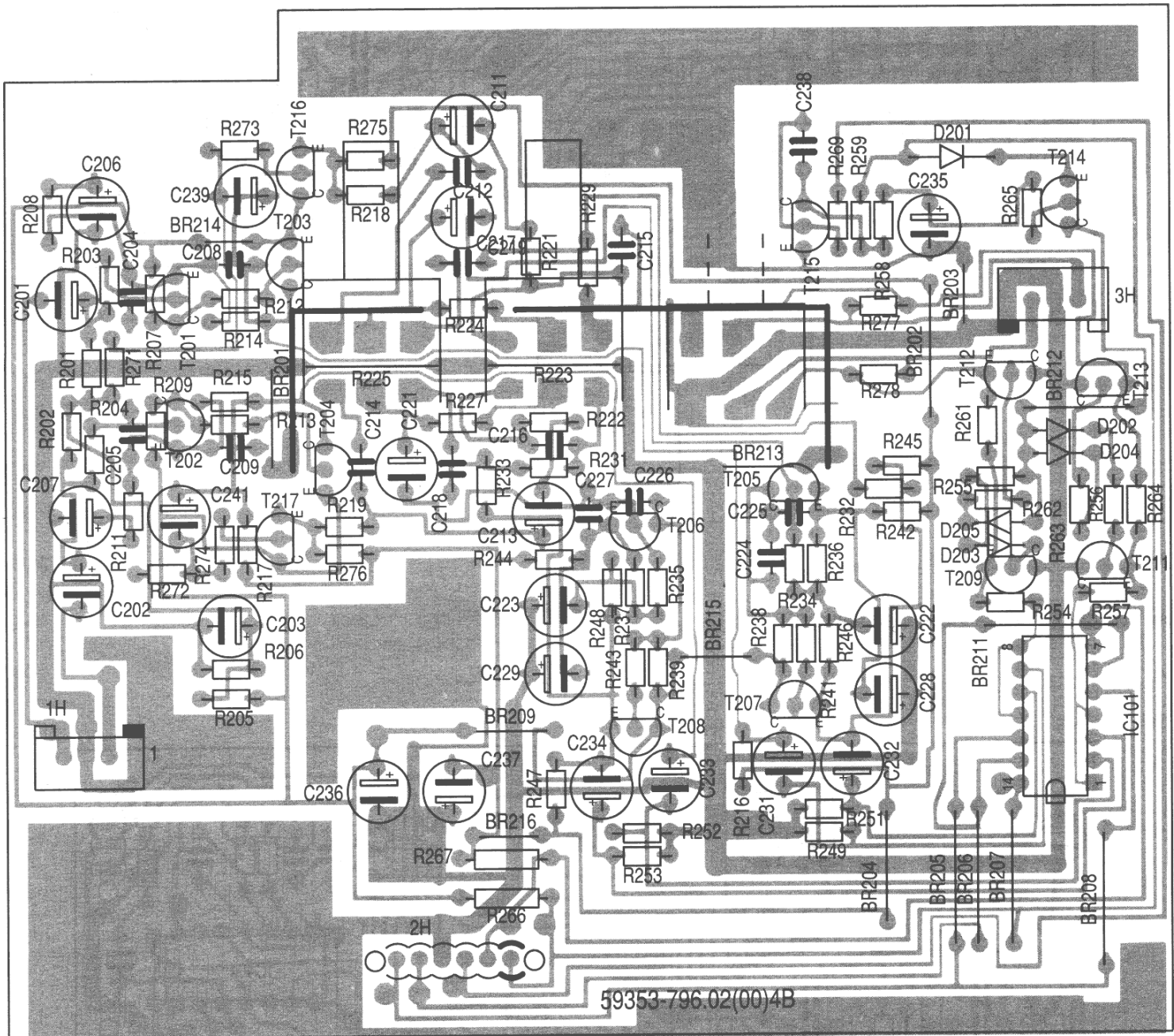

Schaltbild Lautstärkereglerrplatte / Circuit Diagram Volume Board

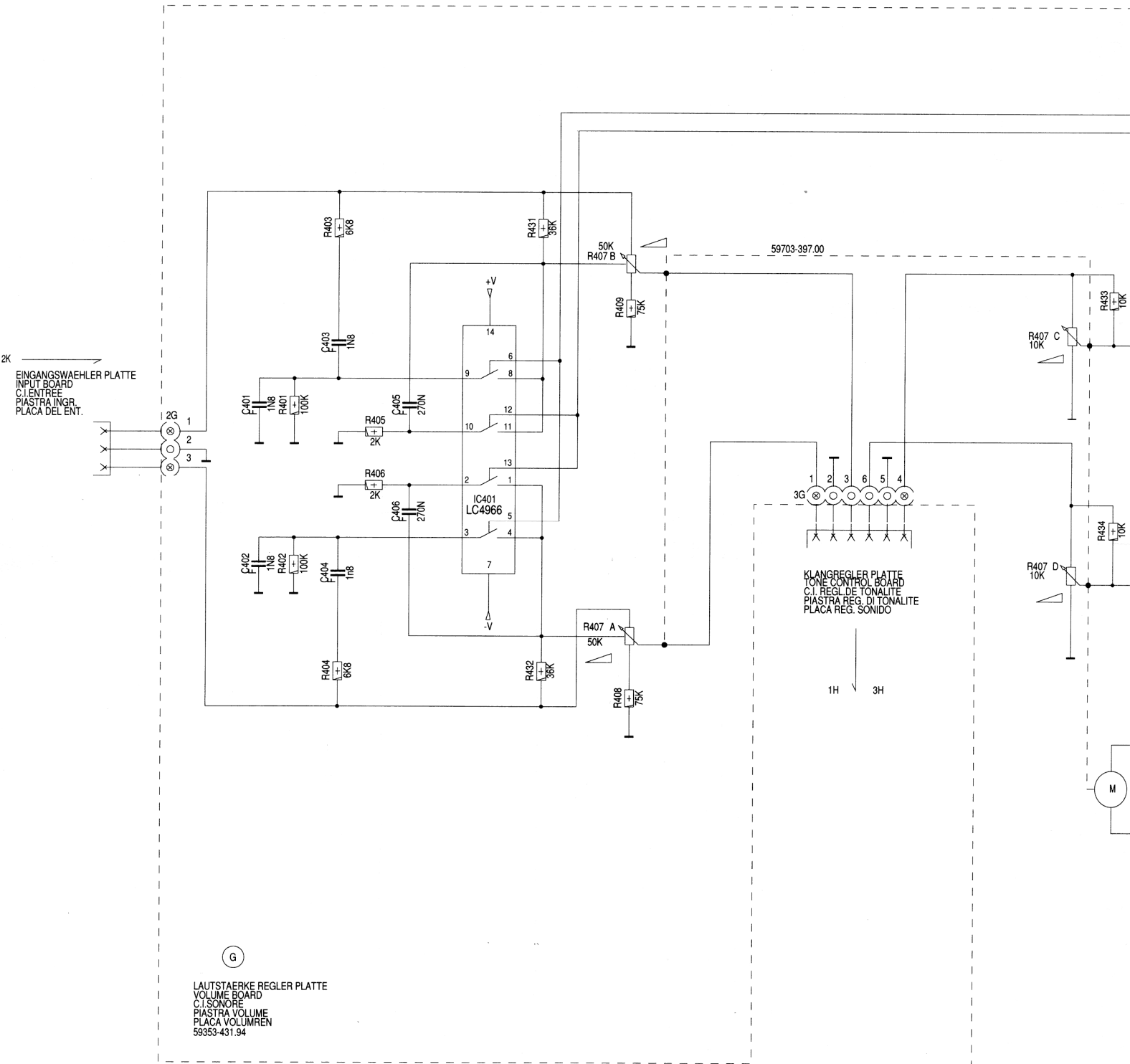

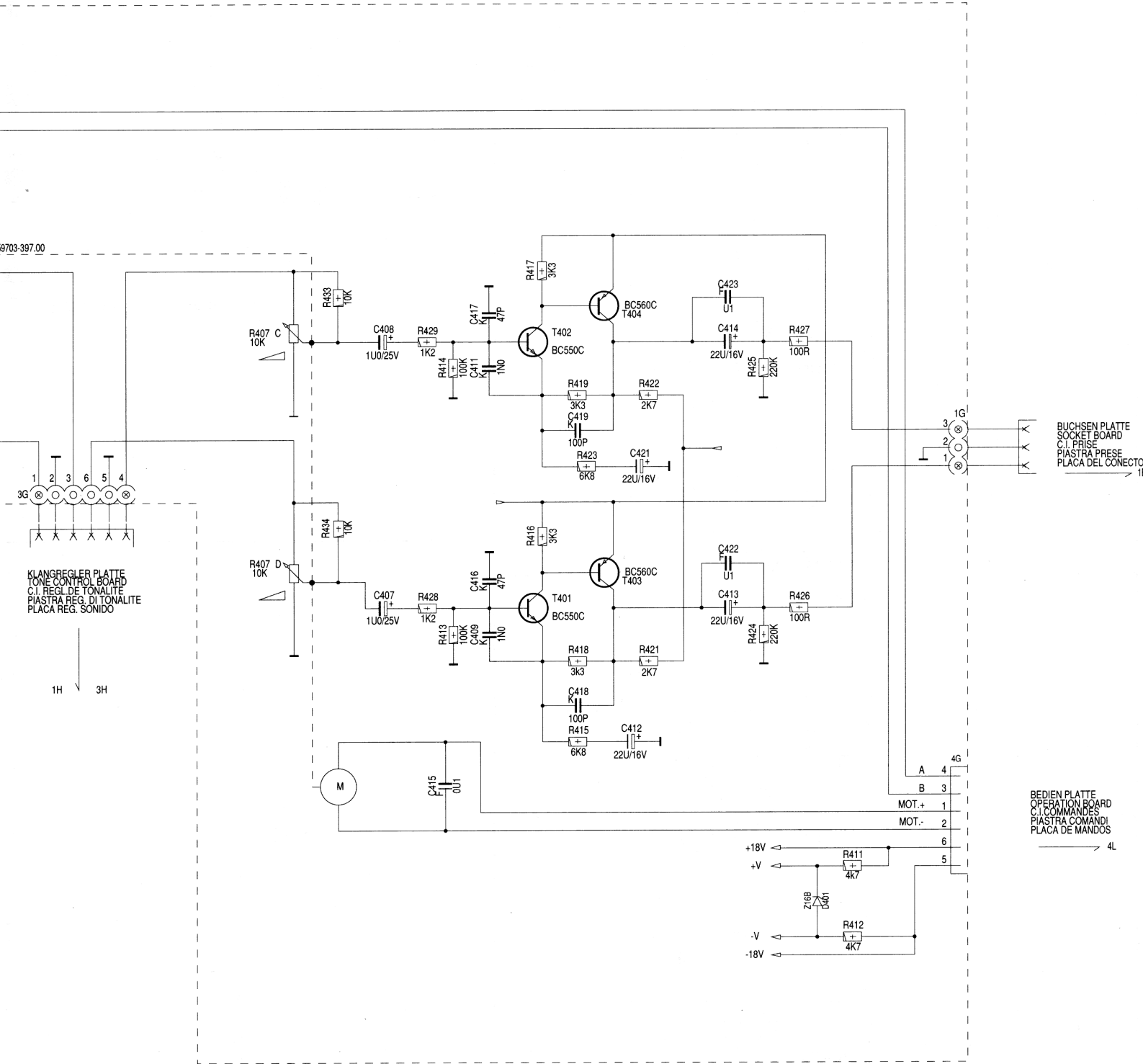

9703-397.00

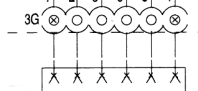

KLANGREGLER PLATTE
TONE CONTROL BOARD
C.I. REGL. DE TONALITE
PIASTRA REG. DI TONALITE
PLACA REG. SONIDO

1H 3H

BUCHSEN PLATTE
SOCKET BOARD
C.I. PRISE
PIASTRA PRESE
PLACA DEL CONECTOR

BEDIEN PLATTE
OPERATION BOARD
C.I. COMMANDES
PIASTRA COMANDI
PLACA DE MANDOS

4L

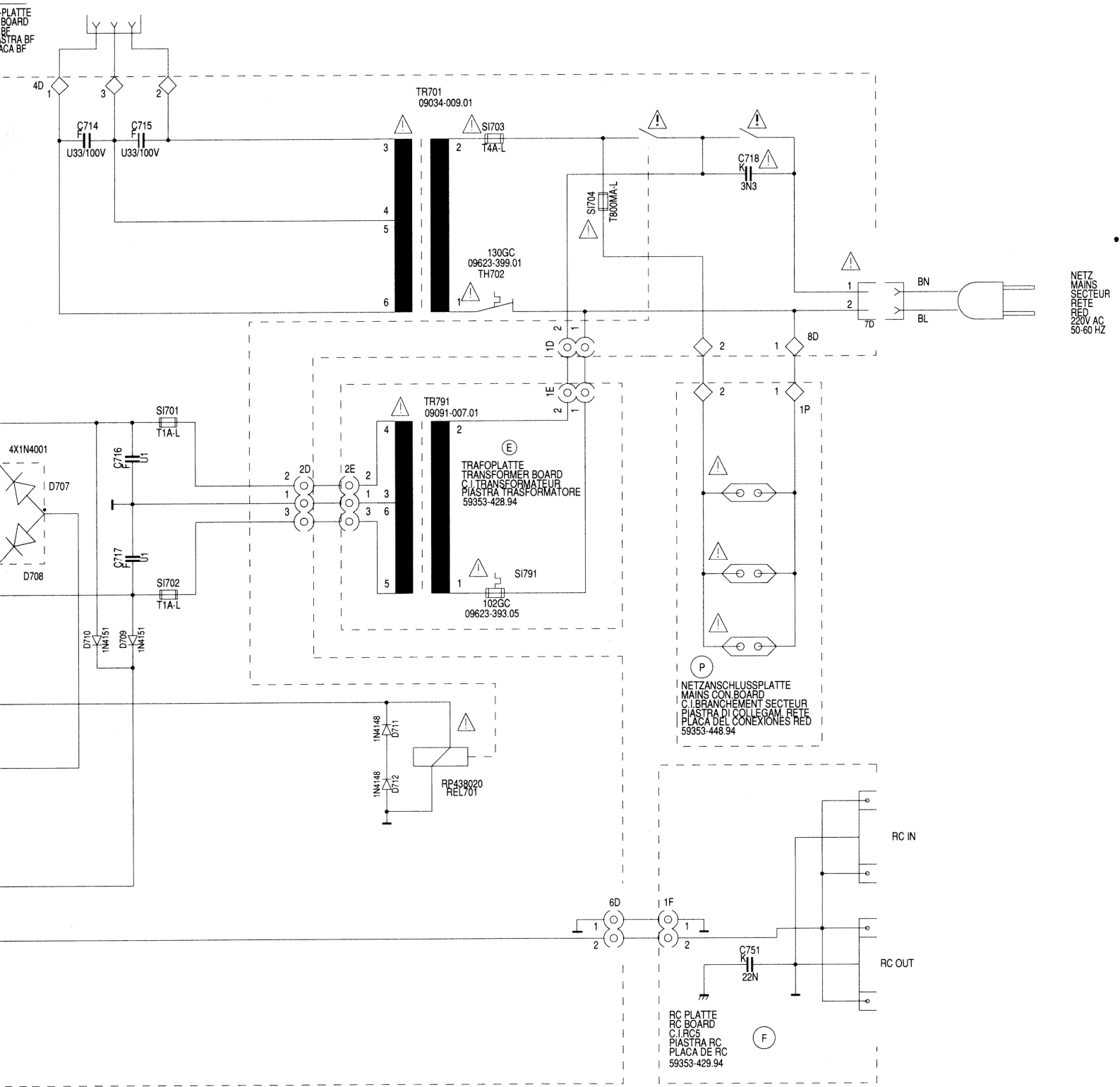

Schaltbild / Circuit Diagram: -Netzteilplatte / Mains Unit Board
-Trafoplatte / Transformer Board
-Netzanschlußplatte / Mains Con. Board
-RC-Platte / RC Board

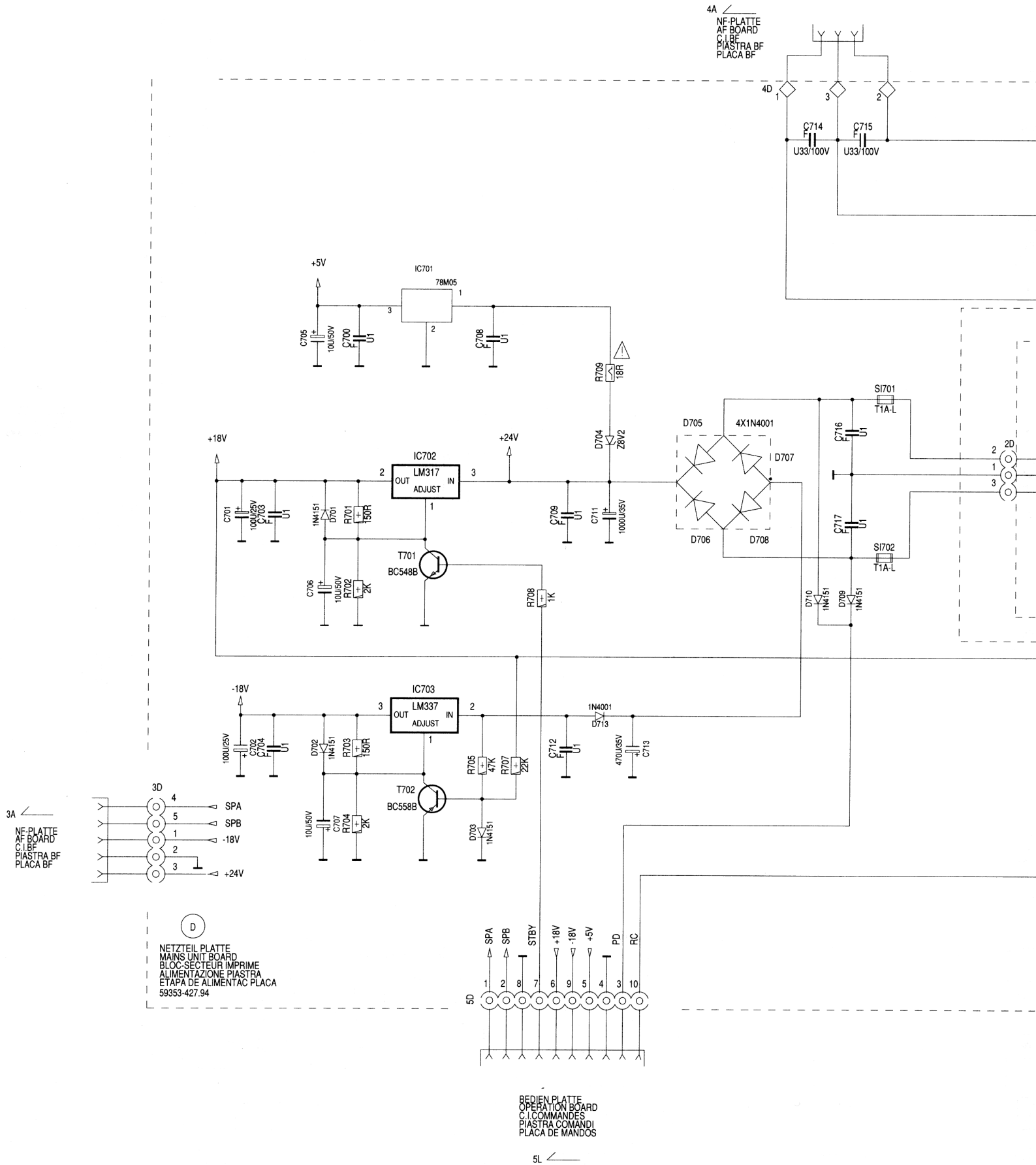

Schaltbild / Circuit Diagram: -NF-Platte / AF Board
-Buchsenplatte / Socket Board
-Kopfhörerplatte / Headphone Board

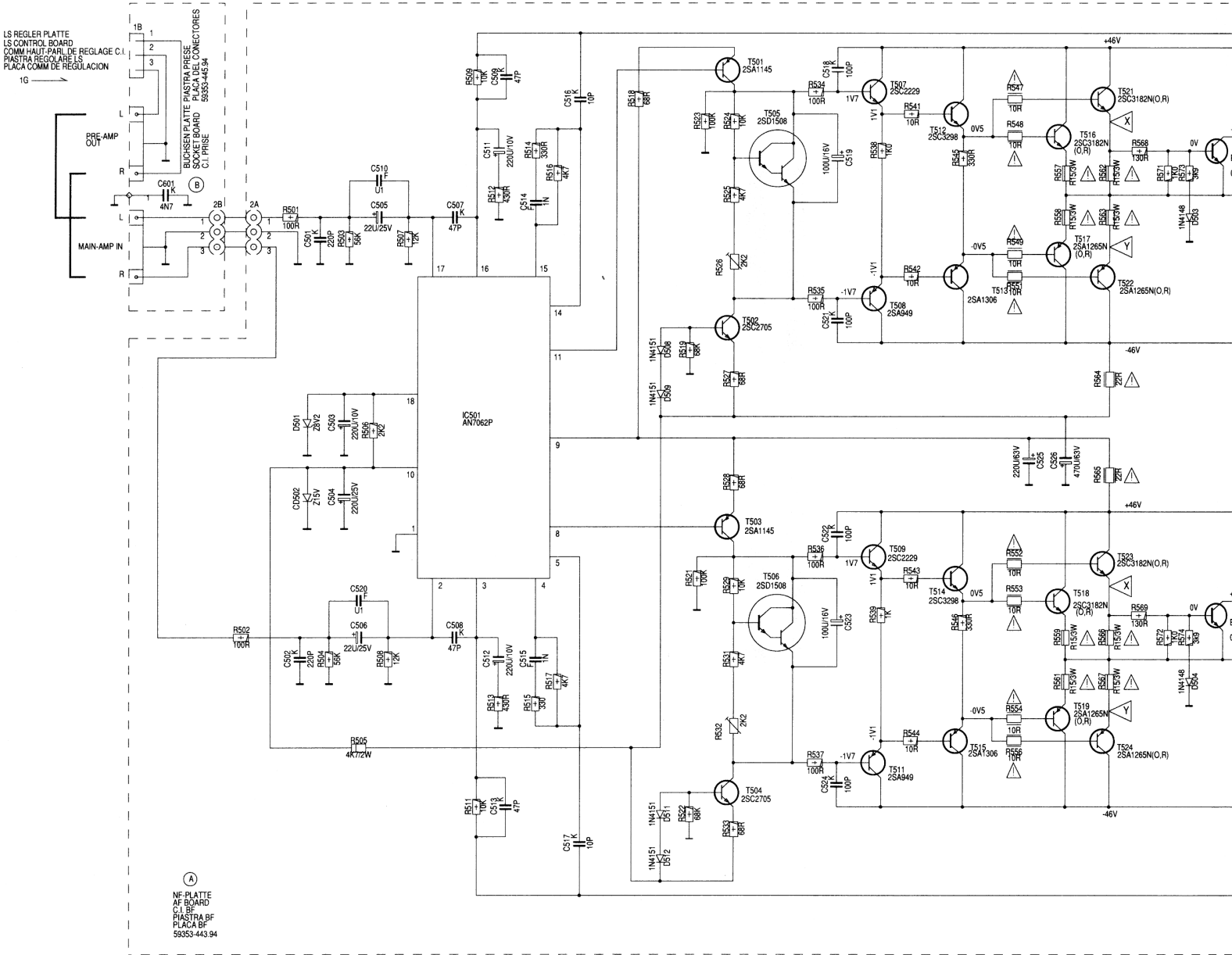

A
 NF-PLATTE
 AF BOARD
 C.I. BF
 PIASTRA BF
 PLACA BF
 59353-443 94

RUHESTROMEINSTELLUNG: MIT R526/532 ZWISCHEN X UND Y 9MV +0.5MV EINSTELLEN.
 SETTING OF QUIESCENT CURRENT: ADJUST WITH R526/532 9MV +0.5MV BETWEEN X AND Y
 REGLAGE DU COURANT DE REPOS: REGLER AVEC R526/532 SUR 9MV +0.5MV ENTRE X ET Y
 REGOLAZIONE CORRENTE DI RIPOSO: TARARA CON R526/532 PER 9MV +0.5MV FRA X E Y



NF-SPANNUNGEN BEI 2 x 8W AN 8 OHM = 8V - AM AUSGANG, 1KHZ, LAUTSTÄRKE VOLL AUF, DEFEAT EIN, BALANCE MITTE, LAUTSPRECHERRELAIS EIN.

AF VOLTAGES AT 2 x 8W INTO 8 OHM = 8V - AT OUTPUT, 1KHZ, VOLUME FULLY UP, DEFEAT ON, BALANCE IN CENTRE SETTING, LOUDSPEAKER SWITCHES ON.

TENSIONS BF POUR 2 x 8W SUR 8 OHM = 8V - A LA SORTIE, 1KHZ, VOLUME AU MAXIMUM, DEFEAT EN SERVICE, REGLAGES DE BALANCE EN POSITION MEDIANE, COMMUTATEUR HAUT-PARLEURS EN SERVICE.

TENSIONI BF ALL'USCITA CON 2 x 8W E 8 OHM = 8V - 1KHZ, VOLUME AL MASSIMO, DEFEAT INSERITO, REGOLATORI DI BILANCIAMENTO AL CENTRO, COMMUTATORI DEGLI ALTOPARLANTI INSERITI.

IC 501 AN 7062 P

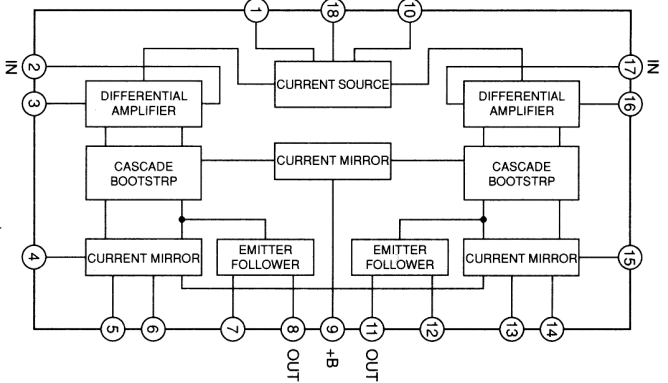

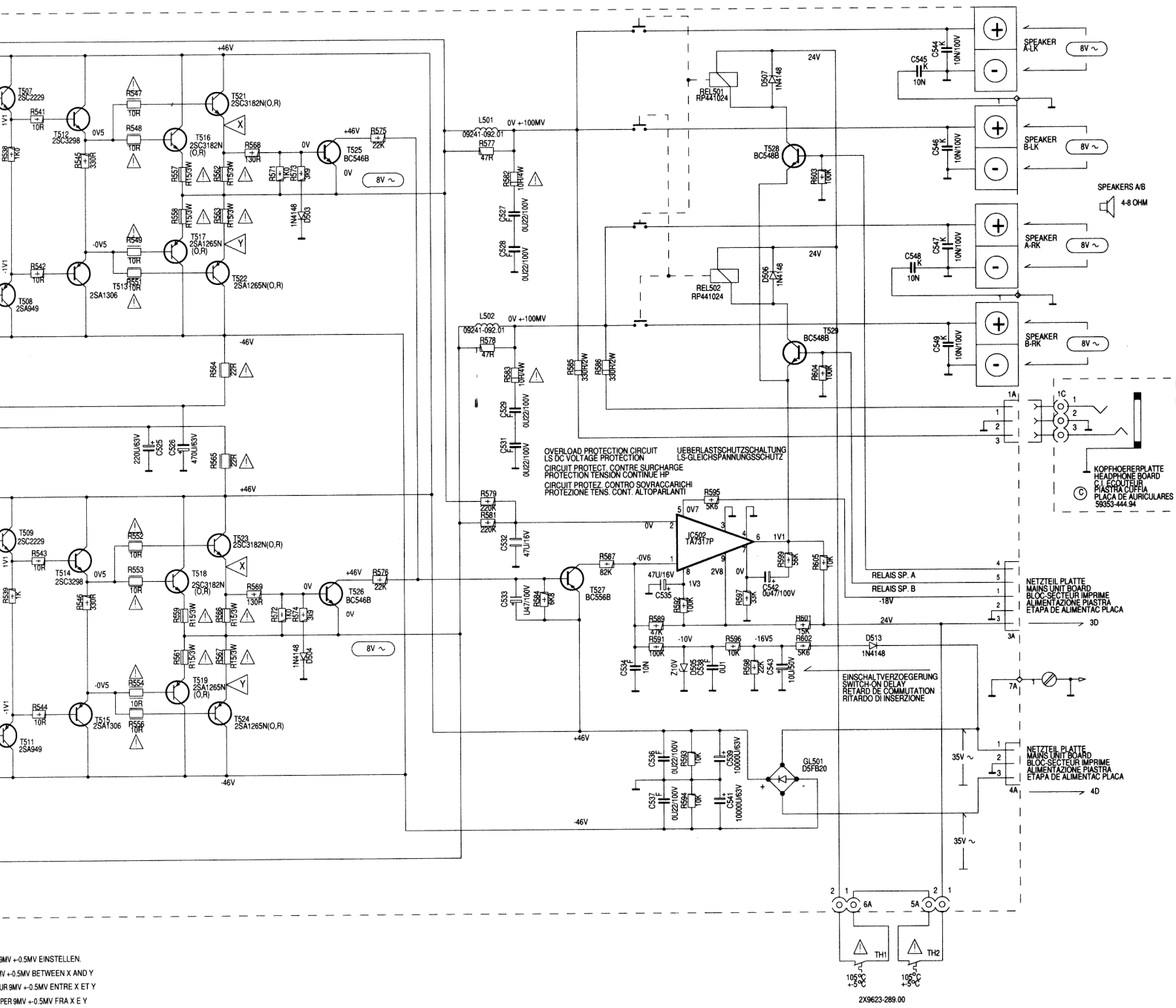

9MV +0.5MV EINSTELLEN.
 9V +0.5MV BETWEEN X AND Y
 9V +0.5MV ENTRE X ET Y
 9V +0.5MV FRA X E Y

2X8623-289.00

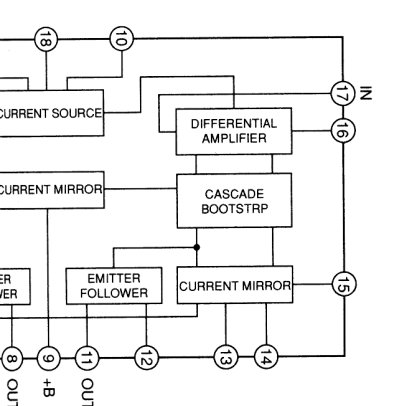

IC 502 TA 7317 P

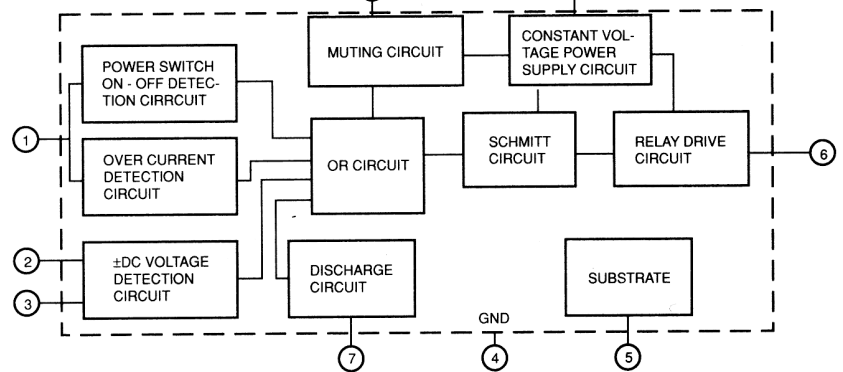

Bedienplatte / Operation Board

Ansicht von der Bestückungsseite / View of components side

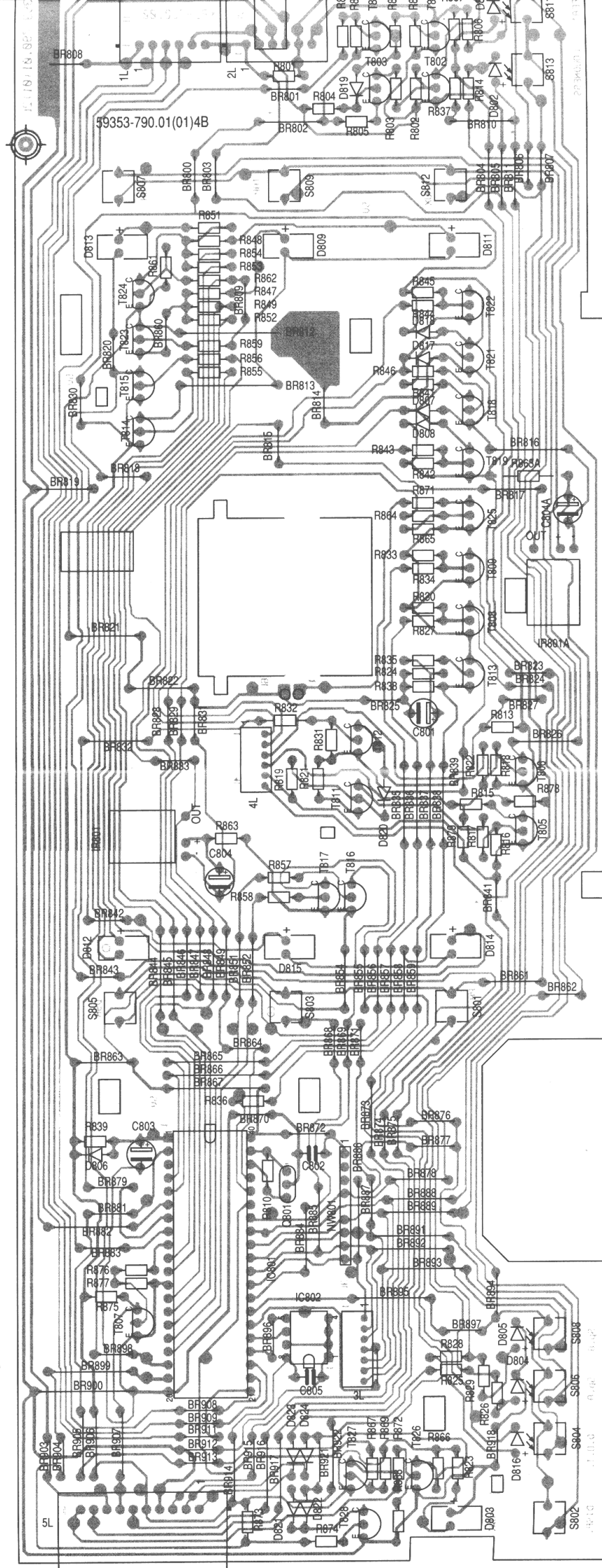

NF-Platte / AF Board

Ansicht von der Bestückungsseite / View of components side

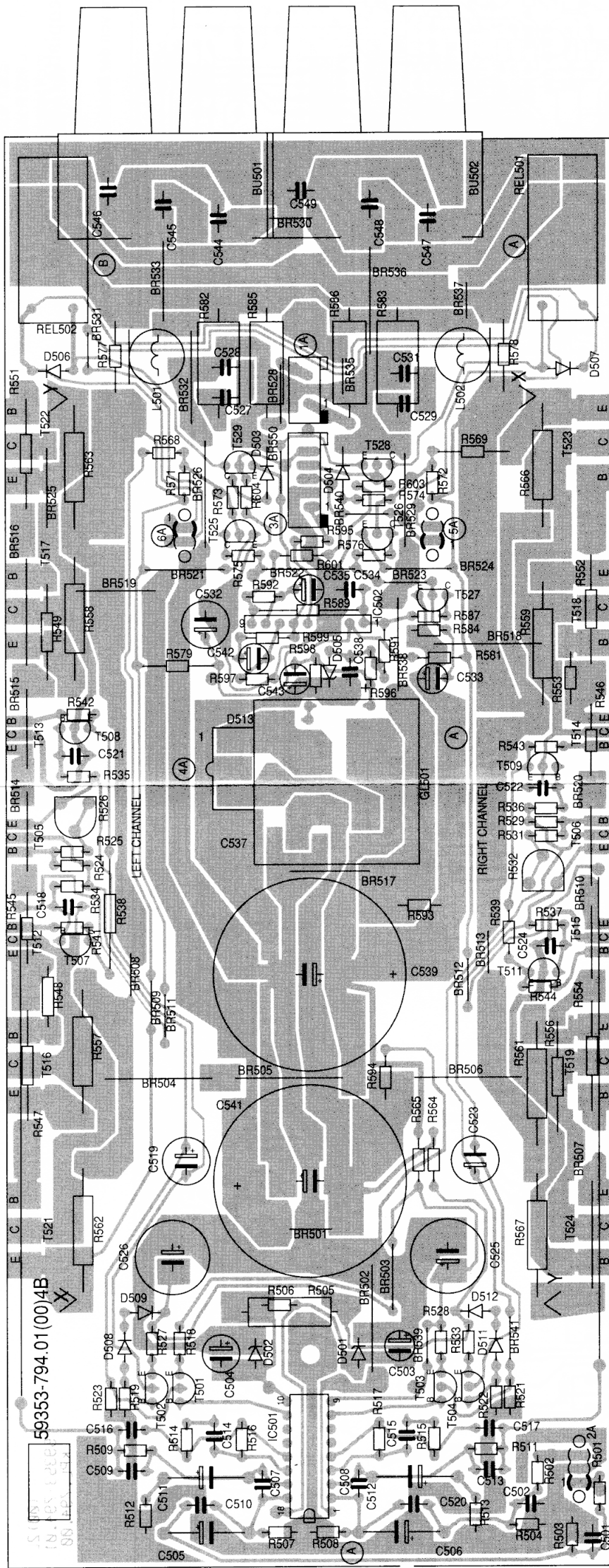

Netzteilplatte / Mains Unit Board

Ansicht von der Bestückungsseite / View of components side

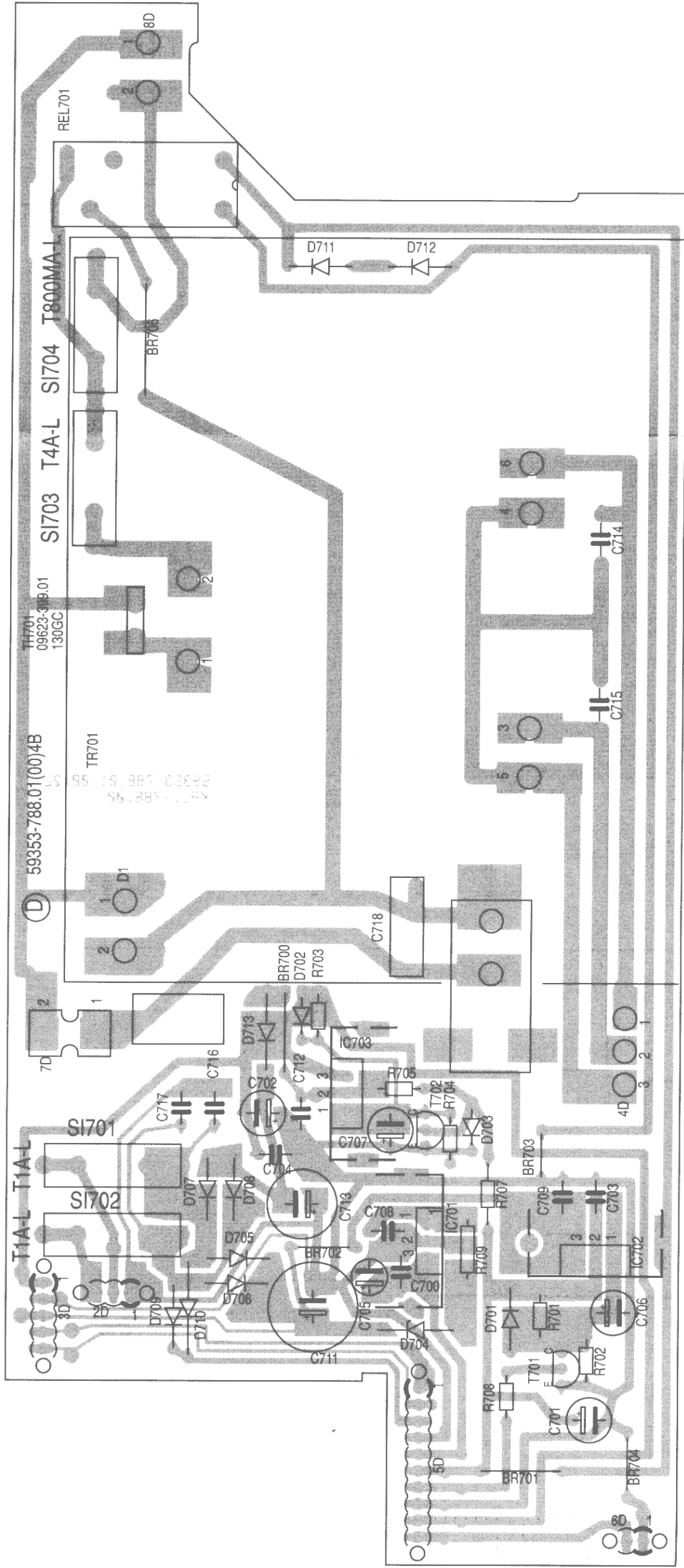

D

Abgleichvorschriften

Meßgeräte:
Digitalvoltmeter

Abgleich	Vorbereitung	Abgleichprozedur
Ruhestrom	Kein Eingangssignal. Lautstärke auf Null. Gerät mindestens 2 min warmlaufen lassen. Linker Kanal: Digitalvoltmeter zwischen Meßpunkte X und Y. Rechter Kanal: Digitalvoltmeter zwischen Meßpunkte X und Y.	Linker Kanal: Mit R 526 auf 9 mV ± 0,5 mV einstellen. Rechter Kanal: Mit R 532 auf 9 mV ± 0,5 mV einstellen.

GB

Adjustment Procedures

Test equipment:
Digital voltmeter

Adjustment	Preperation	Adjustment Procedure
Quiescent current	No Input Signal. Volume to Minimum. Turn on the set for at least 2 minutes. Left channel: Digitalvoltmeter between testpoints X and Y. Right channel: Digitalvoltmeter between testpoints X and Y.	Left channel: Adjust with R 526 for 9 mV ± 0.5 mV . Right channel: Adjust with R 532 for 9 mV ± 0.5 mV .

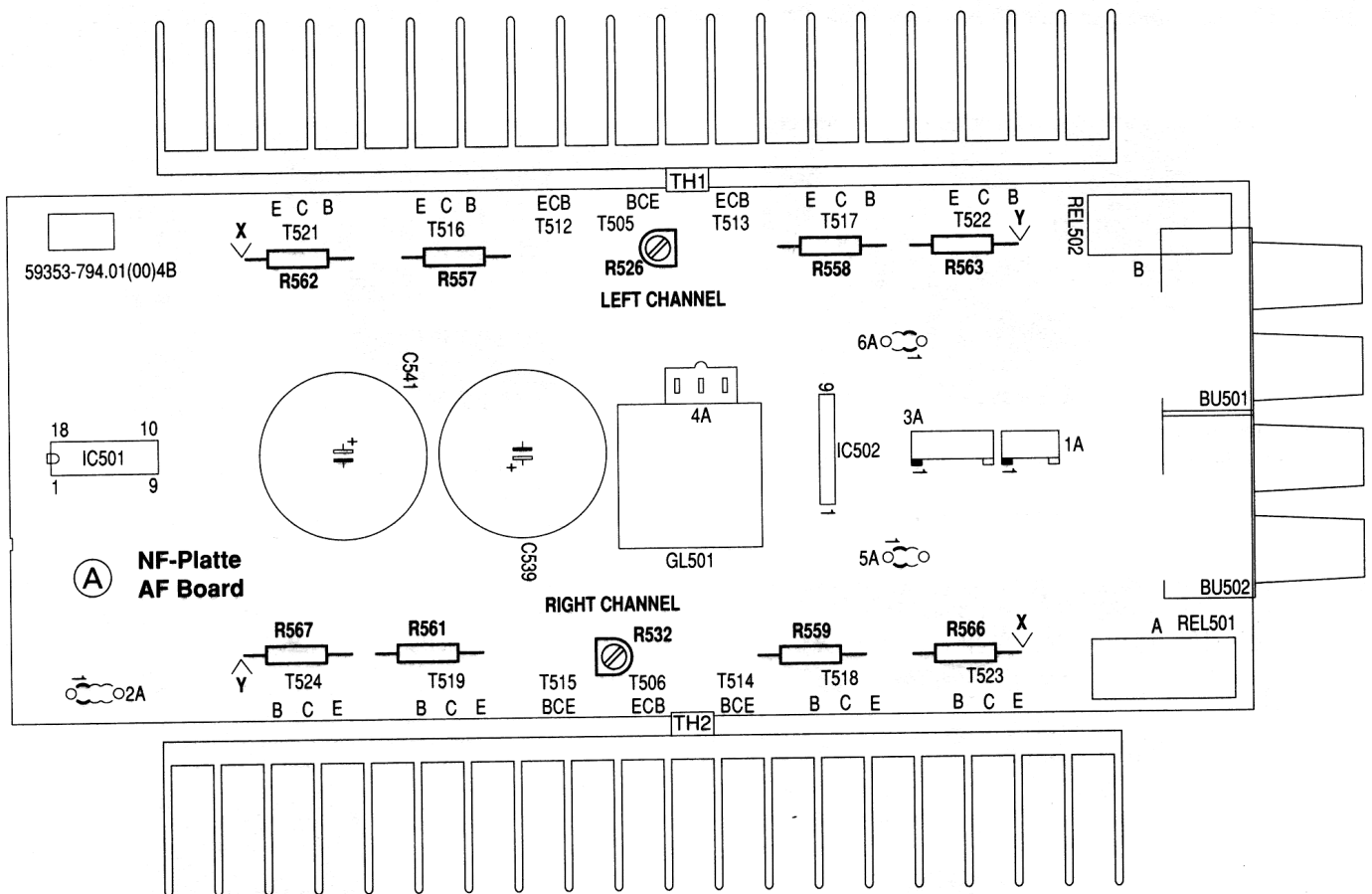

10. Ausbau der Netzteil-, Trafo- und Netzanschlußplatte

- Die Frontplatte ausbauen (siehe Kapitel 2).
- Die Steckverbindung **M** abziehen (Abb. 2).
- Die 4 Schrauben **O** herauserschrauben (Abb. 4).
- Die Schraube **P** herauserschrauben (Abb. 2).
- Die 4 Schrauben **Q** herauserschrauben (Abb. 6).
- Die 4 Schrauben **R** herauserschrauben (Abb. 2).
- Die Netzteil-, Trafo- und Netzanschlußplatte kann jetzt nach vorne herausgenommen werden.

11. Zerlegen der Frontplatte:

- Die Frontplatte ausbauen (siehe Kapitel 2).

11a. Ausbau der Bedienplatte

- Die Lautstärkereglerplatte ausbauen (siehe Kapitel 9).
- Die 7 Schrauben **S** herauserschrauben (Abb. 7).
- Die 6 Rastnasen **T** ausrasten (Abb. 7).
- Die Bedienplatte kann jetzt herausgenommen werden.

11b. Ausbau der Eingangswahltafeln (Abb. 9)

- Mit einem kleinen Schraubendreher die Rastnase **U** ausrasten.
- Die Taste kann jetzt nach außen entnommen werden.

11c. Ausbau der Tasten (Abb. 10)

- Mit einem kleinen Schraubendreher die Taste heraushebeln.
- Ein Abbrechen der Nase **V** ist für die Funktion ohne Bedeutung.

11d. Ausbau des Fensters

- Die 6 Rastnasen **W** ausrasten (Abb. 8).
- Die Schraube **X** herauserschrauben und LED-Platte entnehmen (Abb. 5).
- Das Fenster kann jetzt nach vorne herausgenommen werden.

10. Removing the power supply board, transformer board and the mains connecting board

- Remove the front panel (see para 2).
- Disconnect the plug-in connection **M** (Fig. 2).
- Undo the 4 screws **O** (Fig. 2).
- Undo screw **P** (Fig. 4).
- Undo the 4 screws **Q** (Fig. 2).
- Undo the 4 screws **R** (Fig. 4).
- The power supply board, transformer board and mains connecting board can now be removed.

11. Disassembling the front panel

- Remove the front panel (see para 2).

11a. Removing the operation board

- Remove the volume control board (see para 9).
- Undo the 7 screws **S** (Fig. 7).
- Disengage the 6 catches **T** (Fig. 7).
- The operation board can now be removed.

11b. Disassembling the input selection buttons (Fig. 9)

- Disengage the catch **U** with a small screw driver.
- The button can now be removed towards the outside.

11c. Disassembling the buttons (Fig. 10)

- Lift off the button with a small screw driver.
- Breaking the nose **V** does not affect the function.

11d. Removing the window

- Disengage the 6 catches **W** (Fig. 8).
- Undo screw **X** and remove the LED board (Fig. 5).
- The window board can now be removed towards the front.

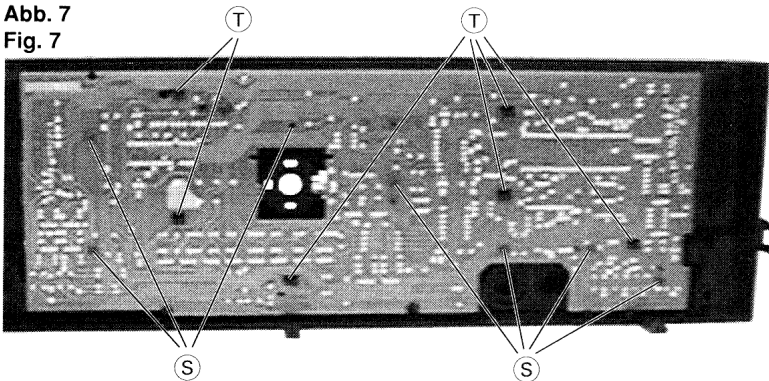
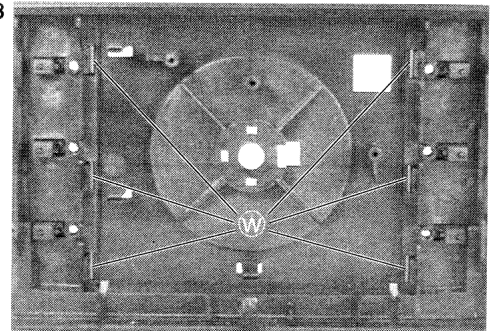
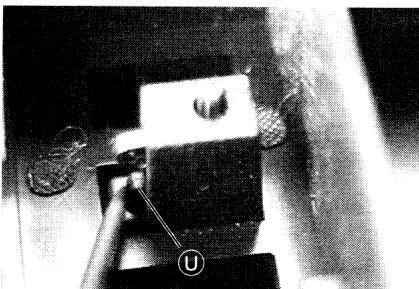
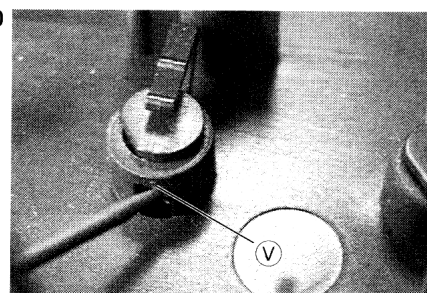
**Abb. 7
Fig. 7****Abb. 8
Fig. 8****Abb. 9
Fig. 9****Abb. 10
Fig. 10****12. Ausbau des Fußes**

- Mit einem Steckschlüssel (Größe 4,5 - 5,5) die Rastung **Y** durchdrücken.
- Beim Einsetzen des Fußes auf Rastnase **Z** achten!

12. Removing the foot

- Push the lock **Y** out of the bottom plate using a socket wrench (size 4.5 - 5.5).
- Take care of the catch **Z** when fitting the foot!

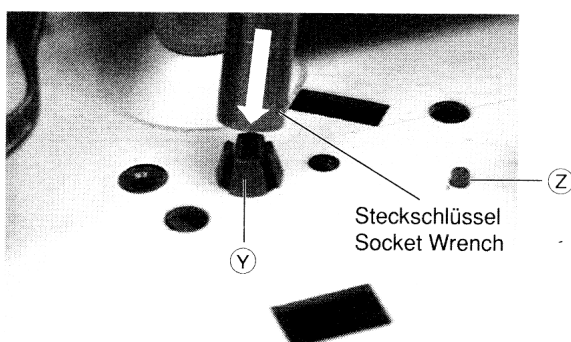
**Abb. 11
Fig. 11****Abb. 12
Fig. 12**