

## Howard Radio Co.

**Model:** 518APC

**Chassis:**

**Year:** Pre June 1940

**Power:**

**Circuit:**

**IF:**

**Tubes:**

**Bands:**

### Resources

[Riders Volume 11 - HOWARD 11-6](#)

[Riders Volume 11 - HOWARD 11-7](#)

[Riders Volume 11 - HOWARD 11-15](#)

MODEL 301APC    MODEL 518APC  
 MODEL 302APC    MODEL 520APC  
 MODEL 308APC    MODEL 580APC

HOWARD RADIO CO.

Automatic Phono. Data

## INSTALLATION AND OPERATING INSTRUCTIONS AUTOMATIC PHONOGRAPH COMBINATION

### INSTALLATION

**PREPARING FOR OPERATION** - Remove the bracket "A" securing the pickup and needle mechanism. This bracket is shown in place in Figure 1. It is held to the motorboard by means of a screw "B". Remove the screw, lift off the bracket and replace screw in motorboard to cover hole. Then remove red bolts "C" and "D" which hold the motorboard secure during shipment. These are also shown in Figure 1. When these bolts are removed it will allow the wood strips to be taken out. "E" and "F".

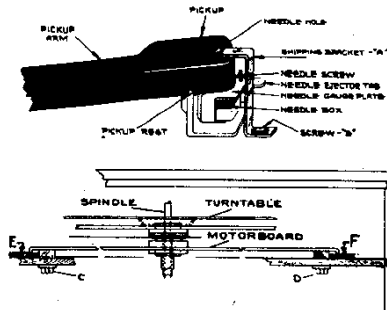

Figure 1 - Unpacking

The two record holder posts (See Figure 6) are covered with paper held in place by rubber bands as is also the pickup. Remove these paper coverings.

THE SCREWS THAT HOLD THE RADIO CHASSIS ARE LOOSEENED JUST ENOUGH TO ALLOW THE WOOD STRIPS (USED IN SHIPMENT) TO BE REMOVED. CAUTION: ONLY A SMALL AMOUNT OF TURNING OF THE WING SCREWS IS NECESSARY. IF THEY ARE TOO LOOSE THE CHASSIS WILL DROP OUT OF POSITION AND THE PUSH BUTTONS WILL NOT OPERATE PROPERLY.

**LOCATION:** The instrument should be located near an electric outlet and on a level surface. The cabinet should not be located near a source of heat such as a radiator or register. If the cabinet is placed parallel to a wall, at least an inch space should exist between the back of the cabinet and the wall, for best tone quality. The instrument must be installed in a level position for proper operation of the phonograph.

**POWER SUPPLY:** Unless otherwise specified on the chassis and on the power transformer, the standard receiver is to be operated from an alternating current only - (105 to 120 Volts, 60 cycle).

**SPEED REGULATION:** There are no adjustments on the Phonograph Motor for speed regulation since the design of the motor is for a constant speed, similar to an electric clock. Be certain that the power line frequency is the same as specified on the motor frame, the standard models being 60 cycle.

### PHONOGRAPH INSTRUCTIONS

**CAUTIONS** - 1. NEVER USE FORCE TO START OR STOP THE MOTION OF ANY PART OF THE RECORD-CHANGING MECHANISM OR PICKUP ARM.  
 2. THE USE OF RECORDS WHICH HAVE BECOME WARPED OR DAMAGED THROUGH IMPROPER CARE MAY CAUSE THE MECHANISM TO JAM AND DAMAGE THE INSTRUMENT. IN ADDITION, RECORDS WHICH HAVE BECOME WARPED WILL SLIDE ON ONE ANOTHER WHEN PLAYING, RESULTING IN UNSATISFACTORY REPRODUCTION.

3. THIS INSTRUMENT IS NOT RECOMMENDED FOR PLAYING 10-INCH AND 12-INCH RECORDS IN MIXED SEQUENCE. IF THE USER DESIRES THIS SERVICE HE MUST BE POSITIVE THAT ALL RECORDS ARE PERFECTLY FLAT AND FREE FROM WARP. THE INDEX AND RECORD REJECT LEVER MUST BE SET AT "10" AND AFTER PLAYING. THE LAST SELECTION THE PICKUP WILL COME DOWN IN POSITION FOR A 10-INCH RECORD AND REPEAT THE PLAYING OF THIS LAST RECORD ON A 10-INCH DIAMETER UNLESS THE TURNTABLE SWITCH IS TURNED OFF. ANY JAMMING OF THE MECHANISM UNDER THESE CONDITIONS INDICATES THAT THE RECORDS USED ARE NOT PERFECTLY FLAT OR THAT THEIR EDGES ARE NOT SUFFICIENTLY SMOOTH TO PERMIT NORMAL OPERATION OF THE SEPARATORS IN DROPPING EACH RECORD IN SEQUENCE ONTO THE TURNTABLE.

4. DO NOT LEAVE RECORDS ON THE RECORD HOLDER POSTS, AS THEY ARE LIABLE TO WARP. KEEP YOUR RECORDS IN A RECORD FILE (ALBUM OF CABINET) WHEN NOT IN USE. IF ANY RECORDS SHOULD BECOME WARPED PLACE THEM ON A FLAT SURFACE WITH A FLAT HEAVY ARTICLE, SUCH AS A LARGE BOOK, ON TOP AND LEAVE THEM IN THIS POSITION FOR A FEW DAYS.

ONLY LOAD YOUR RECORDS ON THE RECORD HOLDER SHELVES AFTER THE PICKUP IS IN ITS REST POSITION AND THE TURNTABLE STOPPED WITH TURNTABLE SWITCH AT "OFF".

**TURNTABLE SWITCH:** The Turntable Switch is a toggle type located in the front of the index plate on the motorboard (See Figure 6). It is used to start and stop the motor.

**INDEX LEVER:** The Index Lever moves in a small arc in the slot in the index plate. (See Figure 6). The plate is labeled for four positions of the lever - "Manual", "12", "10" and "Reject". If a single record is to be played the automatic record-changing feature will not be used and the Index Lever should be set to the "Manual" position.

If either 10 or 12-inch records are to be played automatically the index lever must be moved to the position indicating the size records that are to be played. If 10-inch records are to be played, or 10 and 12 inch mixed, the Index Lever must be set at "10" and if 12-inch records are to be played, the lever must be set at "12". To reject a record being played, or to start the record-changing cycle in case the record just played does not have the standard eccentric or spiral changing groove simply push the lever to the "REJECT" position and let go. The pickup will raise up and swing outwards and the next record will drop down. Upon releasing the lever, it will automatically return to the "10" position. If you are playing a series of 12-inch records, the lever should be returned to the "12" position after rejecting a record. Keep the lever in its "MANUAL" position when not actually playing records automatically.

Before operating the phonograph, either automatically or manually, be sure that the Pickup Arm is down at playing level and can be easily moved by hand. If not, the Index Lever will be in "10" or "12" and an "Eject cycle" must be completed to bring the arm down. To do this, turn the power switch on the radio panel to "ON" position, then throw the turntable switch "ON". The turntable will start to revolve and the cycle of motion of the pickup arm will be resumed. When the Pickup Arm comes down, turn off the turntable switch.

**TO OPERATE THE PHONOGRAPH:** To play records, set the radio Power switch to the "ON" position. With the Index Lever at Manual and the pickup resting on the support over the needle gauge plate, arm in groove, loosen the needle screw and drop a needle, point first, through the needle hole in the pickup. (See Figures 1 and 6). The needle will be stopped in the right position by the needle gauge plate. Press gently on top of pickup to seat it squarely on the gauge plate. Then tighten the needle screw with your fingers.

Lift the Record Holder shelves, Figure 6, with the fingers underneath and revolve to clear the record circle, also push back the lever sticking up adjacent to the rear record holder post. You now have clear access to the turntable. Place the first record upon the turntable with the spindle protruding through the center of the record.

Swing the shelves back into position down in place and load up. For automatic operation seven 10-inch records or six 12-inch records may be stacked on the record holder shelves.

It is not recommended to mix 10 and 12 inch records for automatic operation. Records should never be stacked higher than the spindle.

### STEP BY STEP PROCEDURE FOR OPERATING PHONOGRAPH

A. TO PLAY 10" OR 12" RECORDS INDIVIDUALLY:

1. Move Index Lever to "Manual" position. See Figure 6.
2. Make sure the pickup arm is resting in its groove with pickup over used needle box. See Figures 1 and 6.
3. Lift the record holder shelves and swing outwards. See Figure 6.
4. Push back the vertical lever near the rear record holder post.
5. Place single record on turntable.
6. Turn power on at receiver, and switch to "Phono" position.
7. Turn on turntable switch. See Figure 6. The turntable will start revolving. Wait till it has reached its normal speed.
8. Lift pickup arm and carefully place needle in first groove of record.
9. Adjust "Volume" and "Tone" as for radio. The same controls are used.

The phonograph will not shut off until the turntable switch (Figure 6) or the Receiver switch is turned off.

To repeat the selection on records with the center changing groove, set index lever to the "10" or "12" position depending upon which size record is being played.

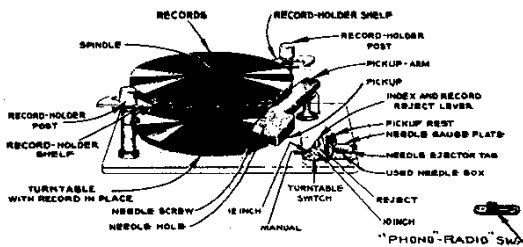
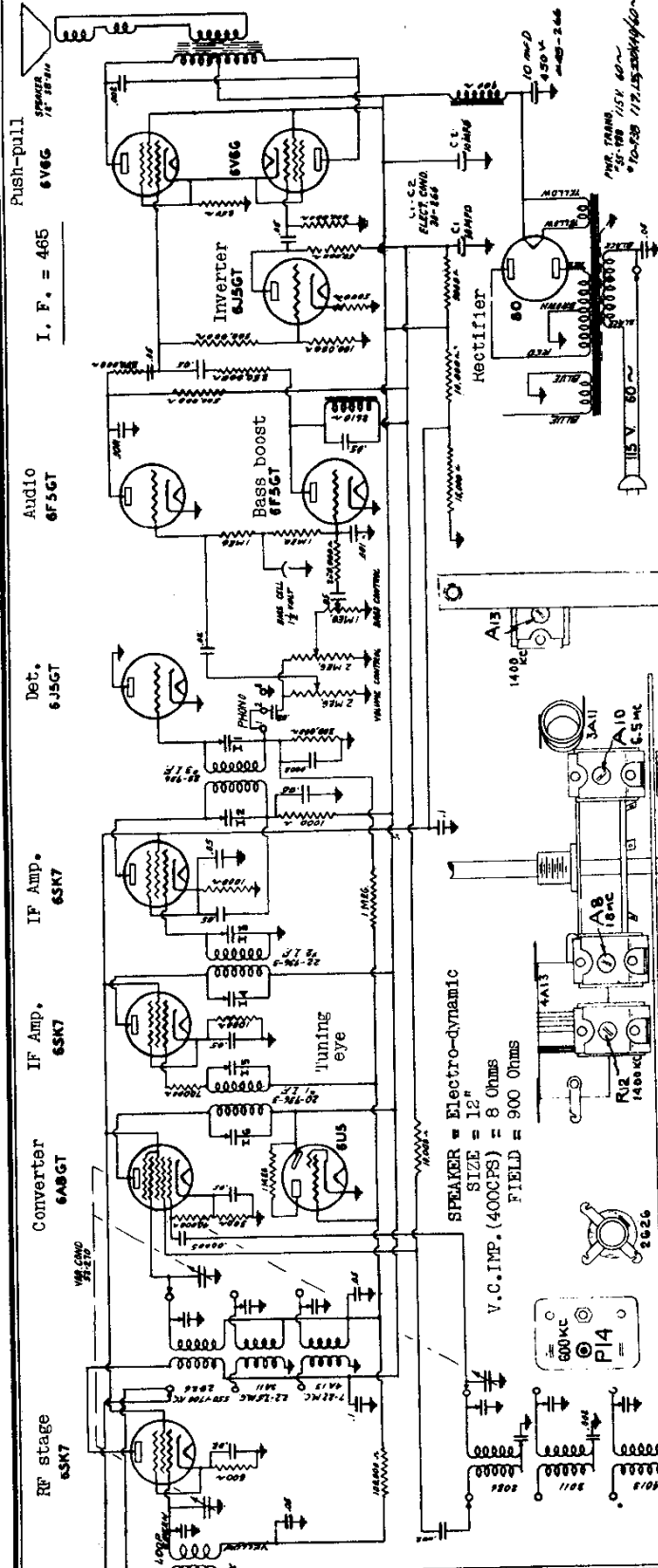

Figure 6



HOWARD RADIO CO.

MODELS 518, 518S, 518APC  
Schematic, Voltage, Socket  
Alignment, Trimmers



POWER SUPPLY - (Standard Models)  
CONSUMPTION 105 WATTS APC + 30  
POWER OUTPUT - (MAX.) = 12 W, up to 8

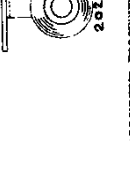
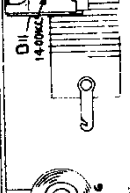
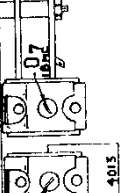
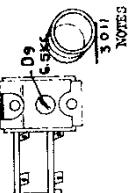
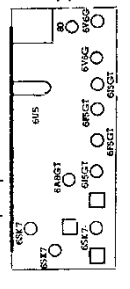

MODEL: 518

DWG. NO.	C-59-715	8-3-39
DWN. BY	CHND. BY	APPROV. BY
R. B. M.	V	

TUBE FUNCTION	TYPE	PLATE	FILTER	FUNCTION	GRID	GRID	GRID	FLATE
6SK7 RF	8	100	245	6F5	Audio	1	1	65
6AB8 Converter	4	100	245	6F5	Base B.	1	1	500
6SK7 1st IF	5	100	245	6F5	Inverter	0	1	150
6SK7 2nd IF	5	100	240	6F5	Output	1 1/2	2 1/2	255
6SK7 3rd IF	5	100	240	6F5	Output	1 1/2	2 1/2	255

NOTES  
A- Each step of the alignment should be repeated in the original order for greater accuracy. Keep output from signal generator low. The I.F. trimmers are reached through the two holes on the top of each I.F. can.  
B- When aligning the short wave bands, do not adjust to the TRACE frequency. For example, if the adjustment is correctly made at 21 MC, then weaker signals will be heard at 21,000 KC less 950 KC, or about 20,070 KC on the dial.  
C- When adjusting this pad, move the tuning hand back and forth and adjust pointer until the peak of greatest intensity is obtained.  
D- See that the tuning hand is set exactly on the last line above 540 when the capacitor is at maximum capacity.  
E- The following dummy antenna circuit is recommended, since it is adaptable for any frequency range. The grid cap should remain in place during alignment.

ALIGNMENT PROCEDURE

Wave-Band Position	Generator Frequency	Generator Connection	Trimmer Adjusted (In order shown)	Trimmer Function
SW	18 MC	6AB Grid	A, B, C, D, E, F, G, H, I, J, K, L, M, N, O, P, Q, R, S, T, U, V, W, X, Y, Z	Ant. Post
SW	18 MC	Ant. Post	A, B, C, D, E, F, G, H, I, J, K, L, M, N, O, P, Q, R, S, T, U, V, W, X, Y, Z	Ant. Post
SW	18 MC	Ant. Post	A, B, C, D, E, F, G, H, I, J, K, L, M, N, O, P, Q, R, S, T, U, V, W, X, Y, Z	Ant. Post
SW	18 MC	Ant. Post	A, B, C, D, E, F, G, H, I, J, K, L, M, N, O, P, Q, R, S, T, U, V, W, X, Y, Z	Ant. Post
SW	18 MC	Ant. Post	A, B, C, D, E, F, G, H, I, J, K, L, M, N, O, P, Q, R, S, T, U, V, W, X, Y, Z	Ant. Post
SW	18 MC	Ant. Post	A, B, C, D, E, F, G, H, I, J, K, L, M, N, O, P, Q, R, S, T, U, V, W, X, Y, Z	Ant. Post
SW	18 MC	Ant. Post	A, B, C, D, E, F, G, H, I, J, K, L, M, N, O, P, Q, R, S, T, U, V, W, X, Y, Z	Ant. Post
SW	18 MC	Ant. Post	A, B, C, D, E, F, G, H, I, J, K, L, M, N, O, P, Q, R, S, T, U, V, W, X, Y, Z	Ant. Post
SW	18 MC	Ant. Post	A, B, C, D, E, F, G, H, I, J, K, L, M, N, O, P, Q, R, S, T, U, V, W, X, Y, Z	Ant. Post
SW	18 MC	Ant. Post	A, B, C, D, E, F, G, H, I, J, K, L, M, N, O, P, Q, R, S, T, U, V, W, X, Y, Z	Ant. Post

