

Hafler[®]
HOME AUDIO COMPONENTS

O W N E R S
M A N U A L

Series • 9130

P O W E R A M P L I F I E R

NOTICE - IMPORTANT SAFETY INFORMATION

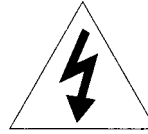
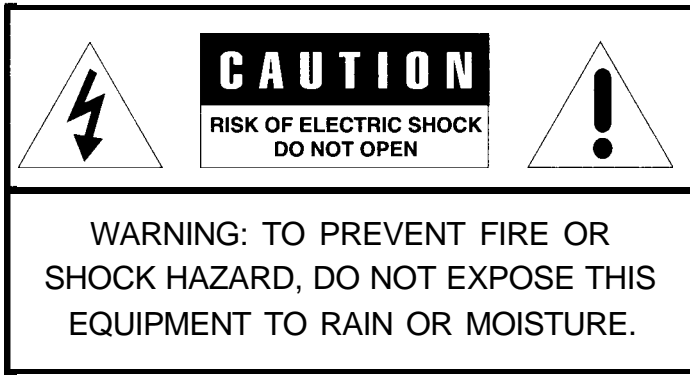

The lightning flash with arrowhead symbol within an equilateral triangle is intended to alert the user to the presence of uninsulated "dangerous voltage" within the products enclosure, that may be of sufficient magnitude to constitute a risk of electric shock to persons.

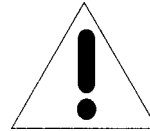

The exclamation point within an equilateral triangle is intended to alert the user of the presence of important operating and maintenance (servicing) instructions in the literature accompanying the appliance.

1. **READ INSTRUCTIONS**

All the safety and operating instructions of your Hafler equipment should be read before power is applied to the equipment.

2. **RETAIN OWNERS MANUAL**

These safety and operating instructions should be retained for future reference.

3. **HEED WARNINGS**

All warnings on the equipment and in the operating instructions are important and should be followed.

4. **FOLLOW INSTRUCTIONS**

All operating and use instructions are important and should be followed.

5. **HEAT**

The equipment should be kept away from areas of high temperature, such as heater vents, radiators, stoves/ovens, fireplaces, etc.

6. **VENTILATION**

The equipment should be used in an area suitable for proper ventilation. Care should be taken not to impede airflow in and around the cabinet. Do not mount on a carpeted shelf or in a sealed enclosure. Allow for proper clearance above the equipment.

7. **WATER AND MOISTURE**

The equipment should not be used in or around water, such as a bathtub, sink, or swimming area. Also, the equipment should not be used in areas prone to flooding, such as a basement.

8. **POWER SOURCES**

The equipment should be connected only to a power source of the same voltage and frequency as that listed on the rear panel above the power cord entry point.

9. **POWER CORD PROTECTION**

Power cords should be arranged so that they do not interfere with the movement of objects in the room: people, fan blades, utility carts, etc. Also, care should be taken that the cord is not pinched or cut, and placed so that it is not in danger of being pinched or cut, as in under a rug, around a tight corner, etc.

10. **POWER CORD GROUNDING**

The power supply cord is of a three wire grounded type, designed to reduce the risk of electric shock sustained from a live cabinet. It is assumed to be of suitable length for most uses of the equipment. The use of extension cords and power strips is discouraged unless they are of suitable rating to deliver the required total current for safe operation of all connected equipment. Furthermore, extension cords or power strips must provide the same three wire grounded connection. It is important that the blades of the equipment's plug be able to fully insert into the mating receptacle. Never remove the round grounding pin on the plug in an attempt to mate to a two wire ungrounded receptacle: use a grounding adaptor with the grounding tab or wire suitably connected to earth ground.

11. **NON-USE PERIODS**
During periods of extended non-use, the power cord should be unplugged from the power source.
12. **CLEANING**
The equipment should be cleaned only as detailed in the operating instructions.
13. **OBJECT AND LIQUID ENTRY**
Care should be taken so that objects and/or liquids, such as cleaning fluids or beverages, are not spilled into the enclosure of the equipment.
14. **DAMAGE REQUIRING SERVICE**
Hafler equipment should be serviced by qualified service personnel when:
 - A. The power supply cord or plug has been damaged, or
 - B. Objects have fallen, or liquid has been spilled into the equipment, or
 - C. The equipment has been exposed to rain, or
 - D. The equipment does not appear to operate normally or exhibits a marked change in performance, or
 - E. The equipment has been dropped, or the enclosure has been damaged.
15. **SERVICING**
The user should not attempt to service the equipment beyond that which is described in the operating instructions. All other service should be referred to qualified service personnel.
16. **CARTS AND STANDS**
The equipment should be used with carts or stands only of sufficient strength and stability for the use intended.

An equipment and cart combination should be moved with care. Quick stops and starts, excessive force, and uneven surfaces may cause the equipment and cart combination to topple.

TABLE OF CONTENTS

PERFORMANCE SPECIFICATIONS	4
General Information	4
INSTALLATION	
Rackmounting	5
Ventilation/Placement	5
Line Voltage..	5
OPERATION/CONNECTIONS	
Power Cord Connection/Power Switch	5
Inputs	5
Front Panel View Diagram	6
Rear Panel View Diagram	7
Outputs	8
Gain Controls..	8
Mono/Stereo Switching	8
Soft Turn-On System	8
Thermal Protection System	8
CIRCUIT HIGHLIGHTS	9
ADDITIONAL INFORMATION	
Loudspeaker Load Impedance Considerations	9
Changing Line Voltage Rating	10
Adjusting Bias	10
General Troubleshooting Hints	11
Ground Loops	11
Cleaning/Maintenance	12
Functional Block Diagram	13
Parts List	14
Component Layout Diagram	15
Circuit Schematic Diagram	17
SERVICE POLICY AND LIMITED WARRANTY	19

PERFORMANCE SPECIFICATIONS

All specifications are for 20 Hz - 20 kHz, at full power into 8 ohms, unless specified otherwise.

Power Rating: 65 watts per channel (8 ohms)

Rated THD: less than 0.008%

Full Power Bandwidth: 4 Hz to 40 kHz

Signal to Noise Ratio: greater than 100 dB, unweighted

Input Impedance: 22,000 ohms

Input Sensitivity: 1.1 volts RMS

Damping Factor: 100 to 1 kHz, 50 to 10 kHz

Controls: Power Switch, Left/Right Gain Controls, Mono/Stereo Switch

Inputs: Right and Left/Mono RCA jacks

outputs: Right, Left, and Mono 5-way Binding Posts

Power Consumption: 40 watts quiescent, 600 watts maximum

Size: 17"(W) x 9"(D) x 3.5"(H) excluding feet, faceplate 17" or 19"(W)
43.2cm(W) x 22.8cm(D) x 8.9cm(H) excluding feet,
faceplate 43.2cm or 48.3cm(W)

Weight: 20 lbs., 9 kg, net.

GENERAL INFORMATION

INSTALLATION

RACKMOUNTING	<p>The 9130 Amplifier is supplied in either a 17" Black Version, or a 19" Silver Version. The 19" model has rackmounting holes provided for installation in equipment racks. The holes are on standard EIA spacings. Due to conflict with adjacent equipment, it may be advisable to remove the four rubber feet from the bottom of the unit. The feet may be removed from the outside, with no dis-assembly of the chassis necessary.</p>
VENTILATION/ PLACEMENT	<p>The 9130 Amplifier can produce considerable heat during normal operation. The amplifier should be placed on a hard, smooth surface to allow air to circulate beneath the unit. Additionally, allow at least one inch of free space on either side, and several inches above and behind the amplifier to allow air circulation around the heatsinks. This is particularly important when the unit is installed in a closed cabinet.</p> <p>In applications where the amplifier is driving low impedance and/or low efficiency loudspeakers at high levels, thermal shutdown may occur if inadequate ventilation is provided. If this occurs, it may be necessary to move the amplifier to a location with better free air circulation.</p> <p>The amplifier should be located at least several inches away from sensitive components, (such as preamplifiers, tuners, CD players, turntables, etc.) due to the possibility of audible hum or buzz from magnetic radiation.</p>
LINE VOLTAGE	<p>The 9130 Amplifier is configurable for either 100, 120, or 230 volt operation. This is accomplished by moving the Voltage Selector on the printed circuit board. The procedure is detailed in the section "CHANGING LINE VOLTAGE RATING".</p> <p>Make sure that the unit is configured for your local AC line voltage before attempted use. The configuration is labelled directly above the power cord connector. (Units wired for 230VAC may be used over a range of 220 to 240VAC.)</p>

OPERATION/CONNECTIONS

POWER CORD CONNECTION/ POWER SWITCH	<p>Units wired for 100 and 230 VAC are supplied without power cords. Local agents will supply cords with male connectors appropriate to the local standard.</p> <p>Units wired for 120 VAC are supplied with a detachable AC power cord. The female connector plugs into the receptacle provided on the rear panel. This power cord is a standard IEC Type 320, 3-wire, 16 gauge assembly. Should replacement ever be necessary, be sure to replace it with an identical cord.</p> <p>Never remove the grounding pin from the male end of the cord. In applications where a grounded outlet is not available, a ground adaptor should be employed, with the ground tab or wire of the adaptor connected to a suitable earth ground.</p> <p>The AC power cord of the amplifier must be connected to a receptacle capable of delivering a minimum of 600 watts. The convenience outlets of some preamplifiers are not rated for this power level. Before connecting the amplifier, be sure to check the rating of such outlets, and take into account the power consumption of any other connected components to determine the total maximum power consumption.</p> <p>If the amplifier is connected to a component with a switched convenience outlet, then the amplifier's Power Switch may be left ON at all times, and the power controlled by the switched outlet. If the amplifier is connected to an unswitched outlet, then the amplifier's power should be controlled by the front panel Power Switch.</p>
INPUTS	<p>All input connections to the amplifier must be performed with the amplifier off!</p> <p>The left and right audio inputs to the amplifier are via standard RCA jacks. Connect these jacks to the output of the preamplifier or other signal source.</p> <p>When operating the amplifier in the Mono Mode, only the left channel input should be used.</p>

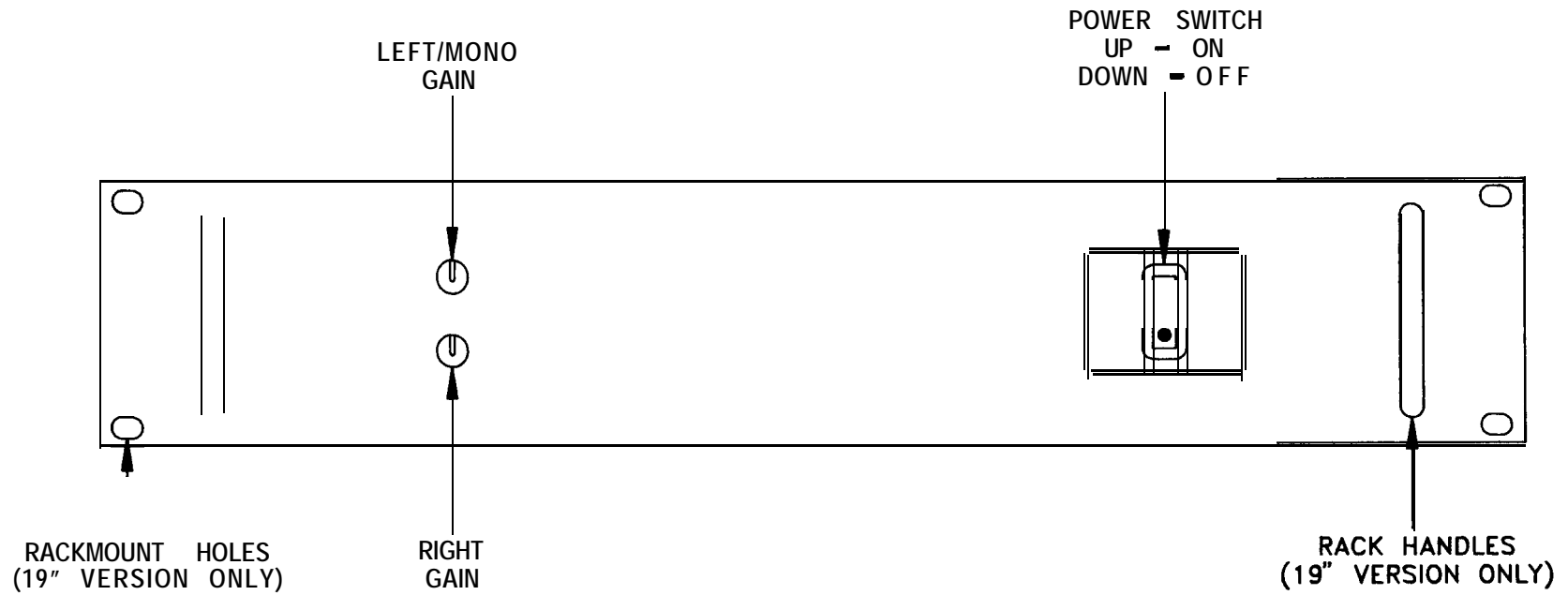

9130 AMPLIFIER FRONT PANEL VIEW

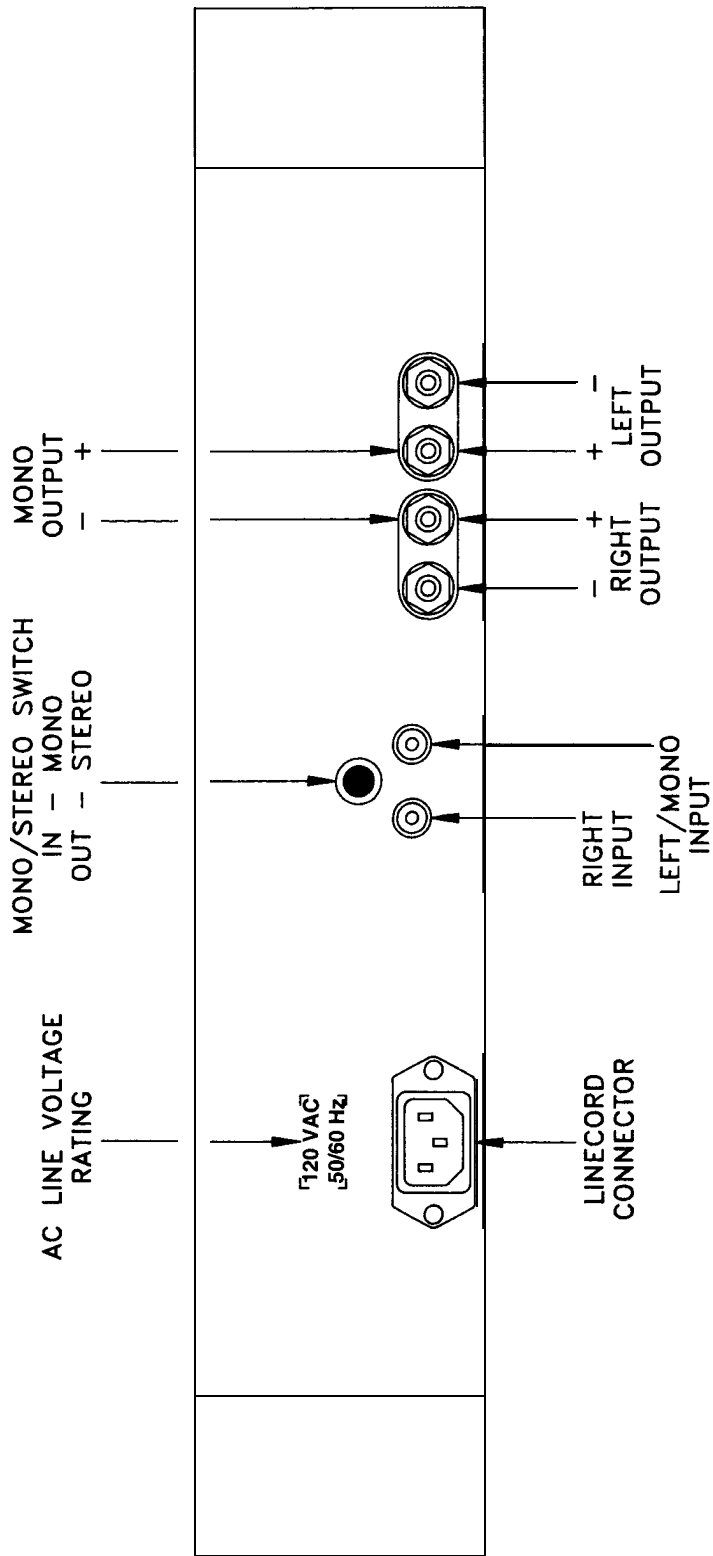

9130 AMPLIFIER REAR PANEL VIEW

OUTPUTS	<p>All output connections to the amplifier must be performed with the amplifier off!</p> <p>The left and right audio outputs from the amplifier are via standard 5-way type, 3/4" spacing, binding posts. Connect these binding posts to the loudspeakers. The amplifier's binding posts will accept single or dual banana plugs, spade lugs, pin plugs, or bare wires. If using bare wires, it is recommended that the ends of the wire be tinned with solder so that no stray strands can cause a short circuit to the chassis or adjacent terminals.</p> <p>To ensure proper speaker phasing and frequency response, be sure to connect each respective amplifier RED (+) terminal to the speaker RED (+) terminal, and the amplifier BLACK (-) terminal to the speaker BLACK (-) terminal. The polarity symbols (+/-) for Stereo Mode are labelled directly above the amplifier's binding posts.</p> <p>For operation in the Mono Mode, a single loudspeaker should be connected to the two RED binding posts only. No connection is made to the amplifier's BLACK binding posts. Connect the speaker's RED (+) terminal to the amplifier's RED terminal labelled (+), and the speaker's BLACK (-) terminal to the amplifier's RED terminal labelled (-). The polarity symbols (+/-) for the Mono Mode are labelled above the polarity markings for the Stereo Mode.</p>
GAIN CONTROLS	<p>The 9130 Amplifier is equipped with front panel mounted Gain Controls. These controls may be used to attenuate the input signal to the amplifier. The maximum clockwise position of these controls applies the full input signal to the amplifier. Intermediate positions of these controls will partially attenuate the signal, and the full counter-clockwise position attenuates the input signal completely.</p> <p>Most applications will dictate that these controls be set to their maximum clockwise position. In situations of unusually high level signal sources, or for matching levels in multiple amplifier installations, it may be desirable to use an intermediate position of the Gain Controls. Unless intentionally introducing different gain levels in the two channels of the amplifier, these controls should normally be set at the same rotational position.</p> <p>In the Mono Mode, the Left Gain Control affects the overall gain of the amplifier. The Right Gain Control has no effect.</p>
MONO/ STEREO SWITCHING	<p>The 9130 Amplifier may be operated in the normal two channel Stereo Mode, or may be converted (bridged) to a higher power, single channel amplifier in the Mono Mode.</p> <p>Operation of the Stereo/Mono switch must be performed with the amplifier off! Set the Stereo/Mono Switch in the OUT position for Stereo Mode, or in the IN position for Mono Mode. Mono Mode operation requires different input and output connections: consult the sections of the manual titled "Inputs" and "Outputs".</p>
SOFT TURN-ON/OFF SYSTEM	<p>The 9130 Amplifier is equipped with a Soft Turn-On/Off System that gradually activates the amplifier's circuitry to avoid spurious noises as the power supply stabilizes.</p> <p>At turn-off, this same system rapidly deactivates the amplifier's circuitry before the power supply begins to collapse, again eliminating any spurious noises.</p>
THERMAL PROTECTION SYSTEM	<p>The 9130 Amplifier is equipped with a Thermal Protection System that constantly monitors the temperature of the heatsinks. When the heatsink temperature reaches a pre-determined level, the amplifier's circuitry is electronically shut down through the same system that provides the Soft Turn-On function. When the heatsinks cool to a safe operating temperature, normal operation of the amplifier resumes.</p>

CIRCUIT HIGHLIGHTS

The 9130 employs a single ended, current source driven, differential input stage. This stage is connected to the rest of the circuitry through a balanced push-pull current mirror system. A combination current mirror and bias multiplier drive the final output stage driver emitter followers. Special linearizing techniques are used that dramatically reduce harmonic distortion.

The final output stage uses two multiple lateral MOSFET's (Metal Oxide Semiconductor Field Effect Transistors) per channel. These devices, unlike conventional bipolar transistors, have a negative temperature coefficient, which means that they do not exhibit "thermal runaway". Thermal runaway is a phenomenon whereby a transistor heats up as it conducts more current, which causes it to get hotter, and conduct more current, and so on, until the device self destructs. Since MOSFET's are inherently self-protecting, no sonically degrading, complex circuitry is required to monitor and protect the output devices.

Furthermore, these lateral MOSFET's exhibit a very linear input to output transfer function. Their connection in circuits and operating characteristics are very similar to vacuum tubes, which is perhaps responsible for their widely recognized sonic trait of being very "musical" and non-fatiguing.

Conversion to Mono Mode is accomplished by driving the negative input (feedback point) of the right channel with the output of the left channel. This causes the right channel to mirror exactly the output of the left channel, but 180 degrees out of phase. This creates twice the voltage swing to be available across the two red output binding posts. This simple method of bridging the amplifier (involving only one resistor) eliminates the costly and sonically degrading inverter circuitry used in other amplifiers.

The Thermal Protection System consists of thermistors (temperature sensitive resistors) mounted to the heatsinks, connected to a comparator system that activates when the heatsinks reach an unsafe operating temperature. The output of the comparator system is connected to a small transistor switch that turns off the input stage of the amplifier, which effectively shuts down the entire amplifier. When the heatsinks cool to a safe temperature, the amplifier is turned on again.

The Soft Turn On/Off System cooperates with the Thermal Protection System by sensing the output of the high voltage power supply. At power up, when both the comparator and power supply have stabilized to normal operating levels, the Soft Turn On System activates the amplifier circuitry through the same transistor switch in the input stage. At power down, the system deactivates the amplifier rapidly before the power supply begins to collapse. This system eliminates spurious noises during the turn on/off cycle.

The power supply utilizes a large EI type transformer with dual multi-tapped primaries to allow alternate connections for world-wide voltage operation. Selection of the various voltage options is made via a simple multi-position plug inside the unit.

The transformer feeds a conventional split full-wave bridge rectifier system. Power supply capacitance is 6800 UF per rail. Further power supply de-coupling is provided for the input stage of each channel.

ADDITIONAL INFORMATION

LOUDSPEAKER LOAD IMPEDANCE CONSIDERATIONS

The 9130 Amplifier is suitable for use with a wide variety of loudspeaker types and load impedances. Operation into impedances below 4 ohms is not recommended, as little additional power is available below 4 ohms. Operation at very high power levels into low impedances for extended periods may overheat the amplifier, but no damage will occur due to the Thermal Protection System.

In the Mono Mode, some additional consideration is required when driving low impedances. When a stereo amplifier is converted (bridged) into a single channel mono amplifier, each half of the bridged amplifier "sees" only half of the loudspeaker's load impedance. For example, when driving an 8 ohm load in the Mono Mode, each channel is actually loaded to 4 ohms. Therefore, it is not recommended to operate the amplifier in Mono Mode into impedances below 8 ohms. It is usually better to use a stereo amplifier of higher power rating (rather than two bridged amplifiers of lower power) when driving low impedances.

CHANGING LINE VOLTAGE RATING

The 9130 Amplifier is equipped with a simple means to adjust the AC line voltage rating for 100, 120 or 230 volts AC, 50/60 Hz. The configuration is labelled above the power cord connector. If the amplifier will be used in a location that requires a different line voltage, use the following procedure to change the configuration. Review the modification instructions before attempting this procedure. If any doubts exist about one's ability to change the line voltage, it is advisable that the procedure be conducted by a qualified technician.

NOTE: Units wired for 230 VAC may be used over a range of 220 to 240 VAC. No compromise in safety or performance will result from operation within this range.

WARNING! UNPLUG THE UNIT FROM AC POWER BEFORE ATTEMPTING THIS PROCEDURE. FAILURE TO DO SO CAN RESULT IN SEVERE ELECTRICAL SHOCK.

- 1) Remove the top cover by removing the four hex head screws (two on each side).
- 2) Using the diagram "Component Layout" as a guide, find the white Voltage Selector plug on the printed circuit board located behind the front panel Power Switch. Note that this plug has several alternate positions. Each position is labelled for where the end of the plug is to be aligned for each appropriate voltage. Move this plug to the new desired position, making sure that the plug is fully seated on the mating pins.
- 3) Depending upon which new voltage is chosen, it may be necessary to change the AC line fuse. Locate the clip-mounted Line Fuse adjacent to the Voltage Selector plug. Replace the fuse with a new as follows:

100 and 120 VAC: 5 amp
230 VAC: 2.5 amp

NOTE: For units wired at 100-120 VAC, the AC line fuse should be a 1/4 x 1-1/4" size, and approved by UL/CSA For units wired at 230 VAC, the fuse should be a 5 x 20mm size, and approved according to IEC 127.

- 4) Replace the cover.
- 5) Obtain a new voltage configuration label from the factory, and affix over the original markings on the rear panel. Alternately, prepare a small self-adhesive label and indicate the new voltage with permanent ink. Relabelling the unit is a vital safety requirement, particularly if the amplifier is sold to a new owner.

ADJUSTING BIAS

The 9130 Amplifier employs a single control per channel to set the bias operating point of the output stage. This bias point is factory set, and normally should not require adjustment for the life of the product. However, should improper bias be suspected, or if repairs have been made that would require a readjustment of bias, the following procedure should be used. Review the instructions before attempting this procedure. If any doubts exist about one's ability to set the bias, it is advisable that the procedure be conducted by a qualified technician.

WARNING! UNPLUG THE UNIT FROM AC POWER BEFORE ATTEMPTING THIS PROCEDURE. FAILURE TO DO SO CAN RESULT IN SEVERE ELECTRICAL SHOCK.

REQUIRED TEST EQUIPMENT: Milliammeter capable of measuring at least 130 mA.

- 1) Remove the top cover by removing the four hex head screws (two on each side).
- 2) Using the diagram "Component Layout" as a guide, find the fuses labelled F1 and F2 for the left channel, or F1 01 and F102 for the right channel.
- 3) Working on one channel at a time, remove either one (and only one) of the fuses. Connect the milliammeter to the two fuse clips, and set the meter to a scale capable of measuring at least 130 mA.

WARNING! THE NEXT STEP OF THIS PROCEDURE CAN EXPOSE THE OPERATOR TO UNINSULATED HIGH VOLTAGES. KEEP ALL BODY PARTS CLEAR OF THE INTERNAL CIRCUITRY OF THE AMPLIFIER.

- 4) Apply power to the amplifier, and allow the unit to thermally stabilize for about three minutes. (If using an analog meter, and the meter reads backwards, temporarily remove power and reverse the meter leads.)
- 5) Again referring to the diagram, locate the trimmer potentiometer labelled PI for the left channel, or PI 01 for the right channel. (NOTE: Do not confuse these trimmers with those labelled P2 and P102: these are for distortion control and require specialized test equipment to adjust.) Using a small screwdriver, adjust the trimmer for a measured current of 130 mA.
- 6) Remove power from the amplifier. Wait about one minute for the power supply to discharge, and remove the meter connections. Replace the fuse.
- 7) Repeat steps #2, 3, 4, 5 and 6 for the other channel.
- 8) Replace the cover.

The 9130 Amplifier contains five internal fuses: one for AC line power, and four for DC power supplies. These fuses should not generally blow unless a malfunction has occurred. These fuses should be replaced only by a qualified technician, and only with the exact type(s) and rating of fuse(s) originally supplied. If a fuse is replaced and blows again within a short time, check all output connections for short circuits, or abnormally low speaker load impedances. If all connections and load conditions appear to be correct, disconnect all power immediately and return for service.

If all controls, fuses, cables, etc. seem to be functioning properly, a process of one-at-a-time component substitution should be employed until the defective unit is identified. If only one channel is not functioning properly, a one-at-a-time reversal of interconnect and speaker cables from left to right should reveal the malfunctioning component.

Ground loops are characterized by a low level hum or buzz in the system. Loops are caused by a voltage potential difference between two points in a ground circuit, and aggravated when multiple paths for a given circuit exist. Noise-free audio performance is dependent upon all grounds being at the same potential, with a single path for each ground connection. Ground loops can exist in two forms: 1) loops created in audio interconnects, and 2) loops created between earth grounded chassis.

Mounting components to a rack with metallic rails may introduce ground loops between associated equipment, because the rails can introduce a second ground path. The extent of this problem will depend on the grounding arrangements of associated equipment. Ground loops can occur in non-rackmounted equipment, though it is less common.

If ground loops occur, and any other component in the system has a three wire grounded power cord, the first step should be to use a ground adaptor (with the ground tab or wire of the adaptor not connected) on the power cord plug of the preamplifier. **DO NOT** cut off the grounding pin on the plug! It may be necessary to use additional adaptors on other grounded components if more than two components are earth grounded. (In other words, only one earth ground per system should exist.) Another potential source of multiple earth grounds is from coaxial antenna or cable service feeds for FM or video sources, which usually are (and should be) earth grounded. The ground adaptor(s) should cure this grounding problem as well.

WARNING: The use of ground adaptors (with the ground tab or wire of the adaptor disconnected) will eliminate the safety feature of the grounded power cord. This safety feature is intended to reduce the risk of electric shock should an internal fault in the equipment result in an electrically "live" chassis. Therefore, this method of ground isolation should be employed only when absolutely necessary, rather than as a general practice. When using a ground adaptor for isolation, make sure that the power cord plug is inserted into the receptacle in the same orientation as if no adaptor were present, to maintain the same hot/neutral polarity.

GENERAL TROUBLESHOOTING HINTS

GROUND LOOPS

CLEANING/
MAINTENANCE

SPECIAL NOTE ON VIDEO CABLE "GROUNDS": As mentioned above, the ground conductor of cable service and antenna feeds should be connected to earth ground. Often, however, due to long feed lengths, especially in apartment distribution systems, this ground will be of poor quality and could be a source of noise. This interference is usually characterized by a high frequency noise, rather than a hum or a buzz. If such interference is experienced, a separate earth ground connection should be made from the cable outlet nearest the audio/video equipment to a known good earth ground.

If ground loops exist due to potential differences in the interconnects in rack mounted systems, then it is advisable to isolate the preamplifier chassis from the rack rails. This may be accomplished by sandwiching a thin sheet of insulating material (i.e., plastic washers or several layers of electrical tape, etc.) between the rack and the preamplifier, and securing the unit with non-metallic (i.e., nylon, etc.) hardware. It may be necessary to insulate other components so that only one component is directly connected to the rack rails.

If the faceplate should become soiled, it may be cleaned with a slightly damp, soft cloth and, if necessary, a mild detergent. Do not use any abrasive cleaners or solvents. Unplug the power cord before attempting any cleaning operations.

Except as specifically detailed in the owners manual, there are no user serviceable parts or adjustments inside the 9130 Amplifier, and all servicing should be referred to qualified, authorized personnel.

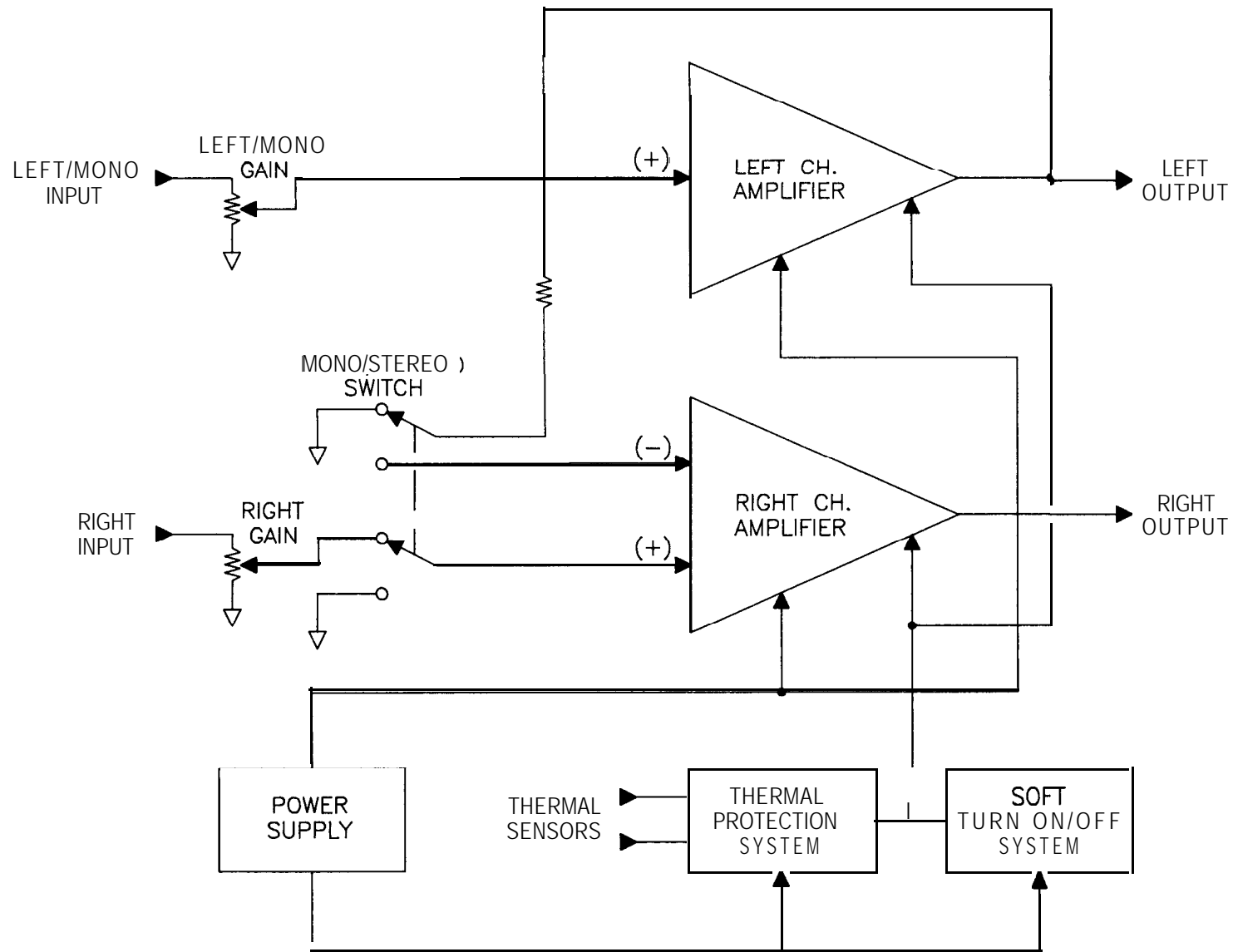

9130 FUNCTIONAL BLOCK DIAGRAM

Parts values and types subject to change without prior notice.

DESIGNATORS 1 -99: LEFT CHANNEL
 101-I 99: RIGHT CHANNEL
 201-299: COMMON PARTS
 301-399: CHASSIS/POWER SUPPLY

DESIGNATOR VALUE PART NUMBER

ALL RESISTORS 1/4 WATT, 1% METAL FILM
 (unless specified otherwise)

R1,R101	1.1K	RMP/4-1101
R2,R102	22.1K	RMP/4-2212
R3,R103	47.5	RMP/4-0475
R4,R104	47.5	RMP/4-0475
R5,R105	10K	RMP/4-1002
R6,R106	681	RMP/4-6810
R7,R107	10	RMP/4-0100
R8,R108	681	RMP/4-6810
R9,R109	2.2K	RMP/4-2211
R10,R110	5K, 5 Watt	RWB5-502
R11,R111	22.1 K	RMP/4-2212
R12,R112	1K	RMP/4-1001
R13,R113	1.1K	RMP/4-1101
R14,R114	22.1K	RMP/4-2212
R15,R115	10	RMP/4-0100
R16,R116	33.2	RMP/4-0332
R17,R117	47.5	RMP/4-0475
R18,R118	475	RMP/4-4750
R19,R119	10	RMP/4-0100
R20,R120	221	RMP/4-2210
R21 ,R121	221	RMP/4-2210
R22,R122	47.5	RMP/4-0475
R23,R123	10	RMP/4-0100
R24,R124	10	RMP/4-0100
R25,R125	30, .5 W, Carbon	RC/2-300
R26,R126	2.7, 1 W, Metal	RM1-027
R27,R127	10, 2 W, Metal	RM2-100
R28,R128	10	RMP/4-0100
R201	22.1K	RMP/4-2212
R202	1K	RMP/4-1001
R203	5.11K	RMP/4-5111
R204	1K	RMP/4-1001
R205	5.11K	RMP/4-5111
R206	5.11K	RMP/4-5111
R207	10K	RMP/4-1002
R208	10K	RMP/4-1002
R209	100K	RMP/4-1003
R210	12.1K	RMP/4-1212
R211	3.3K, .5 W, Carbon	RC/2-332
R212	475K	RMP/4-4753
R213	10K	RMP/4-1002
R214	221K	RMP/4-2213
R215	1.0M	RMP/4-1004
R216	1.0M	RMPM-1004
R217	47.5K	RMP/4-4752
R218	47.5	RMP/4-0475

VR1,VR101	50K Volume	RVH-503G
P1,P101	1 K Trim	RV-102
P2,P102	500 Trim	RVH-501A

ALL CAPACITORS IN MICROFARADS
 (unless specified otherwise)

C1,C101	2.2, Polypropylene	CPP-205C
C2,C102	220p, Polypropylene	CPP-221
C3,C103	330p, Polypropylene	CPP-331
C4,C104	100 NP Electrolytic	CERNP-107
C5,C105	47p, Mica	CM-470
C6,C106	220p, Polypropylene	CPP-221
C7,C107	3p, Mica	CM-030

DESIGNATOR	VALUE	PART NUMBER
C8,C108	0.001, Polypropylene	CPP-102
C9,C109	100, Electrolytic	CER-107C
C10,C110	0.1, Polyester	CP-104A
C11,C111	0.1, Polyester	CP-104A
C12,C112	0.033, Polypropylene	CPP-333
C13,C113	0.1, Polyester	CP-104A
C14,C114	100, Electrolytic	CER-107C
C15,C115	0.1, Polyester	CP-104A
C16,C116	0.1, Polyester	CP-104A
C201	10, Electrolytic	CER-106B
C202	0.1, Polyester	CYV-104
C203	220, Electrolytic	CER-227F
C204	100, Electrolytic	CER-107C
C301	6800, Electrolytic	CER-688D
C302	6800, Electrolytic	CER-688D
C303	0.01, Ceramic	CD-I 03/20
C304	0.01, UL Approved	CD-103A

Q1,Q101	2N5550	SSH-613
Q2,Q102	2N5550	SSH-613
Q3,Q103	2N5401	SSH-708
Q4,Q104	2N5401	SSH-708
Q5,Q105	2N5550	SSH-613
Q6,Q106	2N5401	SSH-708
Q7,Q107	2N5401	SSH-708
Q8,Q108	2N2222A	SSH-611
Q9,Q109	2N5550	SSH-613
Q10,Q110	2N5401	SSH-708
Q11,Q111	2N5550	SSH-613
Q12,Q112	2SK1056	SSH-710
Q13,Q113	2SJ160	SSH-709
Q14,Q114	2N5550	SSH-613
Q201	MPSAO6	SS-102A

U1	LM339	SS-140
TS1	Thermal Sensor	SSH-730
TS2	Thermal Sensor	SSH-730

CR1,CR101	1N4148	SS-162
CR2,CR102	1N4148	SS-162
CR3,CR103	1N4148	SS-162
CR4,CR104	1N4148	SS-162
CR5,CR105	1N4148	SS-162
CR6,CR106	1N4148	SS-162
CR7,CR107	1N4148	SS-162
CR8,CR108	1N4148	SS-162
CR9,CR109	1N4148	SS-162
CR14,CR114	1N4148	SS-162
CR15,CR115	1N4148	SS-162
CR201	1N5245B, 15V	SS-212
CR202	1N5239B, 9.1V	SSH-652
BR301	Diode Bridge	SSH-628
J1,J101	RCA Jack	HW-735G
J2	Left Binding Post	CC-0374
J102	Right Binding Post	CC-0373
J201	AC Voltage Selector	
	Header:	CCH-245
	Housing:	CCH-246
	Pins:	CCH-247
J301	IEC Connector	CCH-233

S1	Stereo/Mono Switch	SWH-510
S301	Power Switch	SWH-0392 (Gray) SWH-0393 (Black)
F1,F101	5 Amp 3AG	FS-005
	5 Amp 5x20mm	FS-0387 (230VAC)
F2,F102	5 Amp 3AG	FS-005
	5 Amp 5x20mm	FS-0387 (230VAC)
LINE FUSE	5 Amp Slo 3AG	FS-005SB (100,120VAC)
	2.5 Amp Slo 5x20mm	FS-0383 (230VAC)

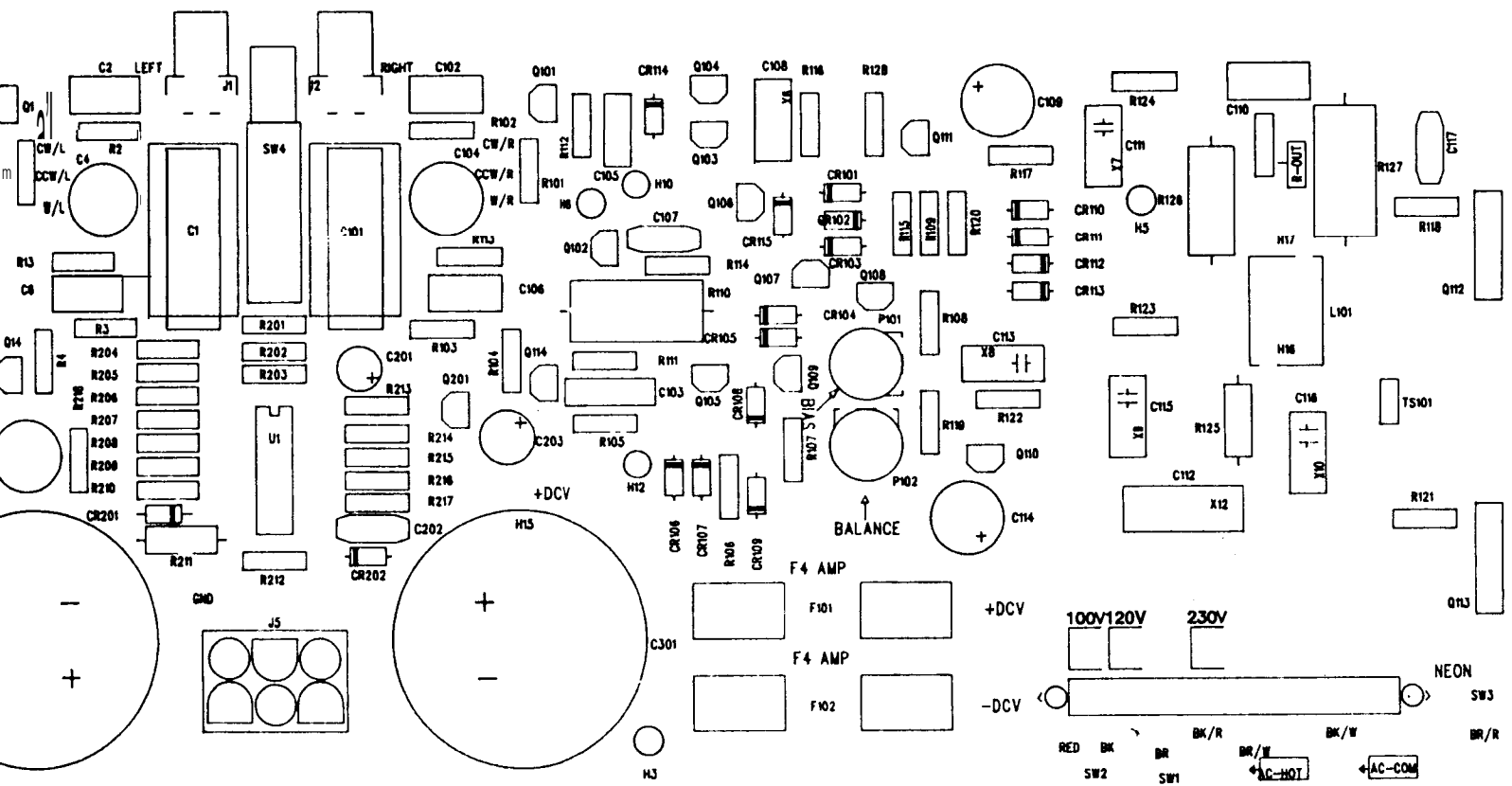

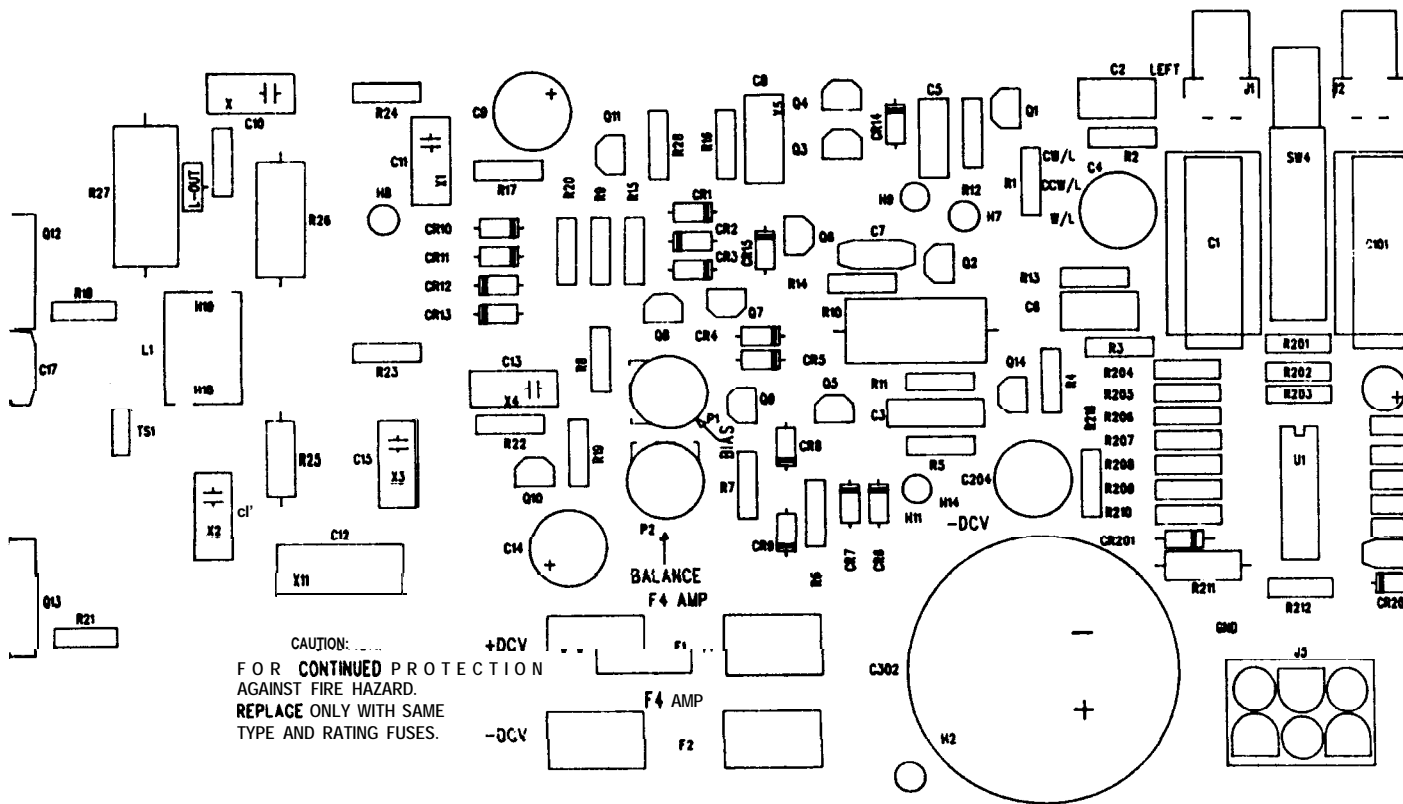

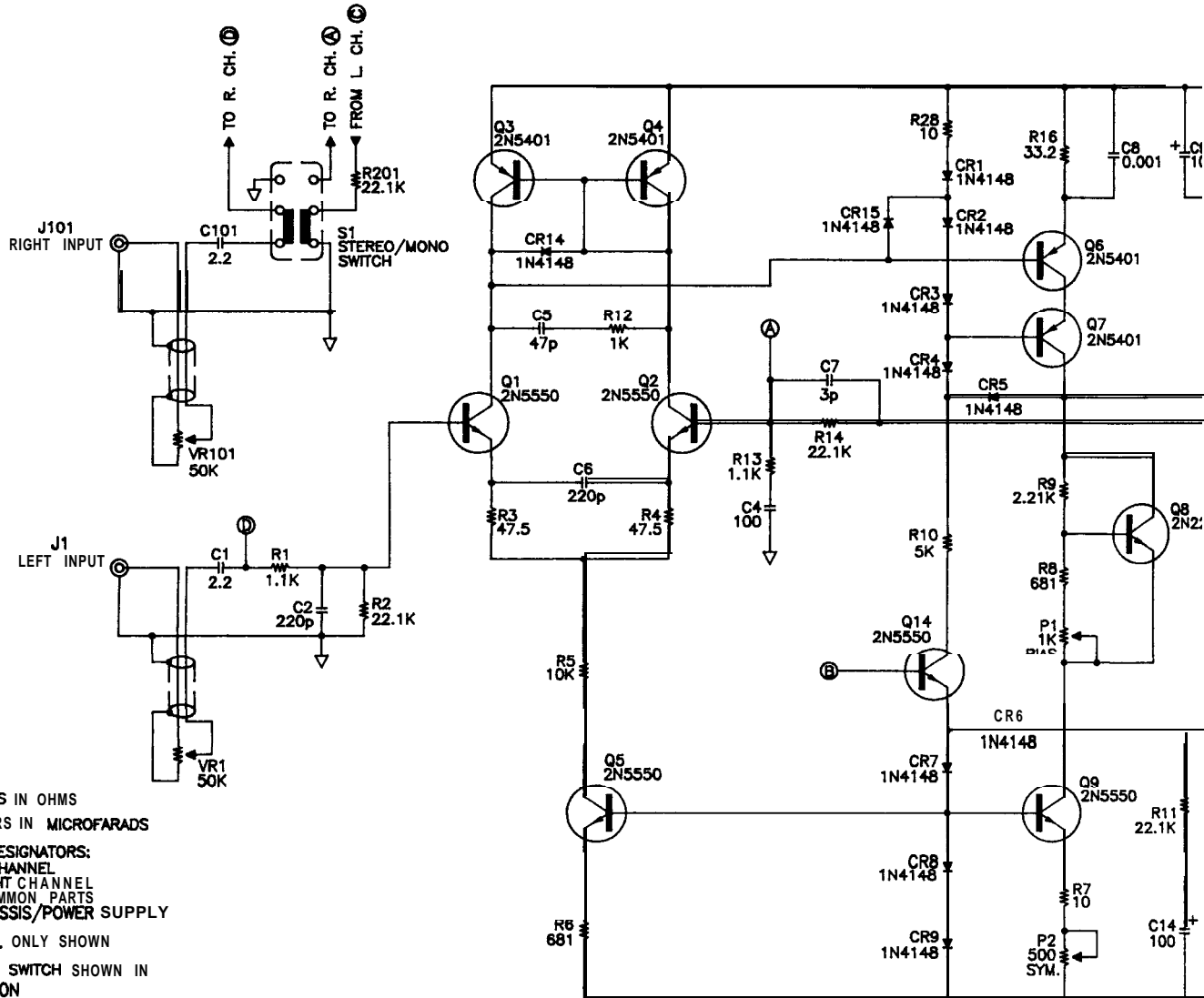

- NOTES:
1. ALL RESISTORS IN OHMS
 2. ALL CAPACITORS IN MICROFARADS
 3. COMPONENT DESIGNATORS:
 1-99: LEFT CHANNEL
 101-199: RIGHT CHANNEL
 201-299: COMMON PARTS
 301-399: CHASSIS/POWER SUPPLY
 4. LEFT CHANNEL ONLY SHOWN
 5. STEREO/MONO SWITCH SHOWN IN STEREO POSITION
 6. VOLTAGE SELECTOR SHOWN IN 100V POSITION
 7. LINE FUSE VALUE:
 100-120VAC: 5A SLO-BLO
 230VAC: 2.5A SLO-BLO

9 130 CIRCUIT SCHEMATIC DIAGRAM

REVISED 9/3/92

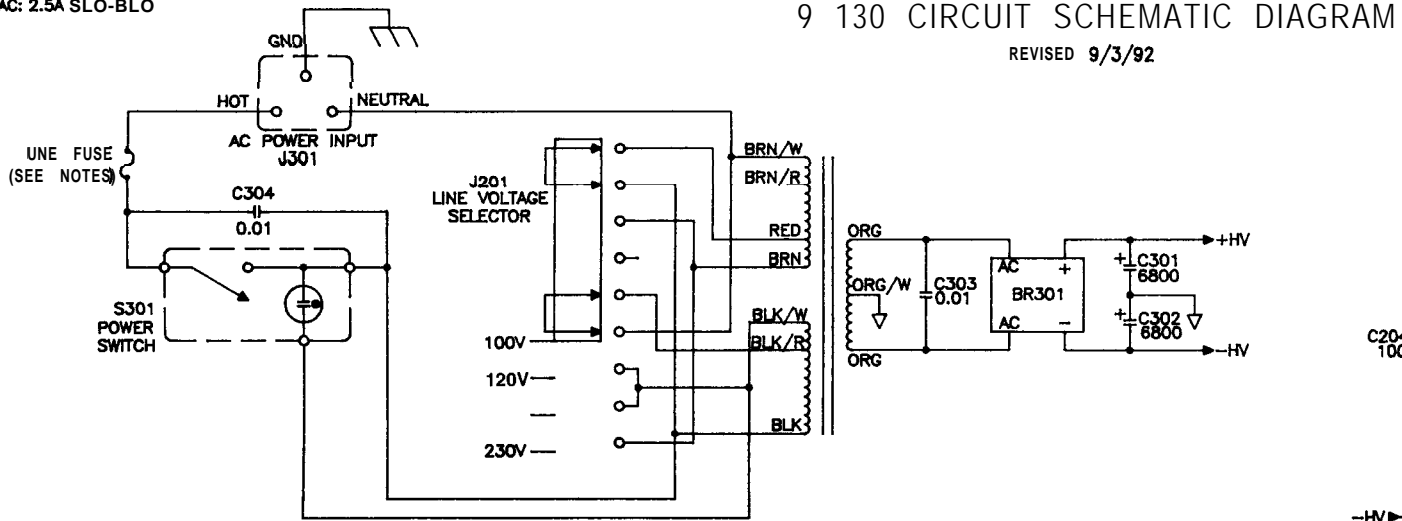

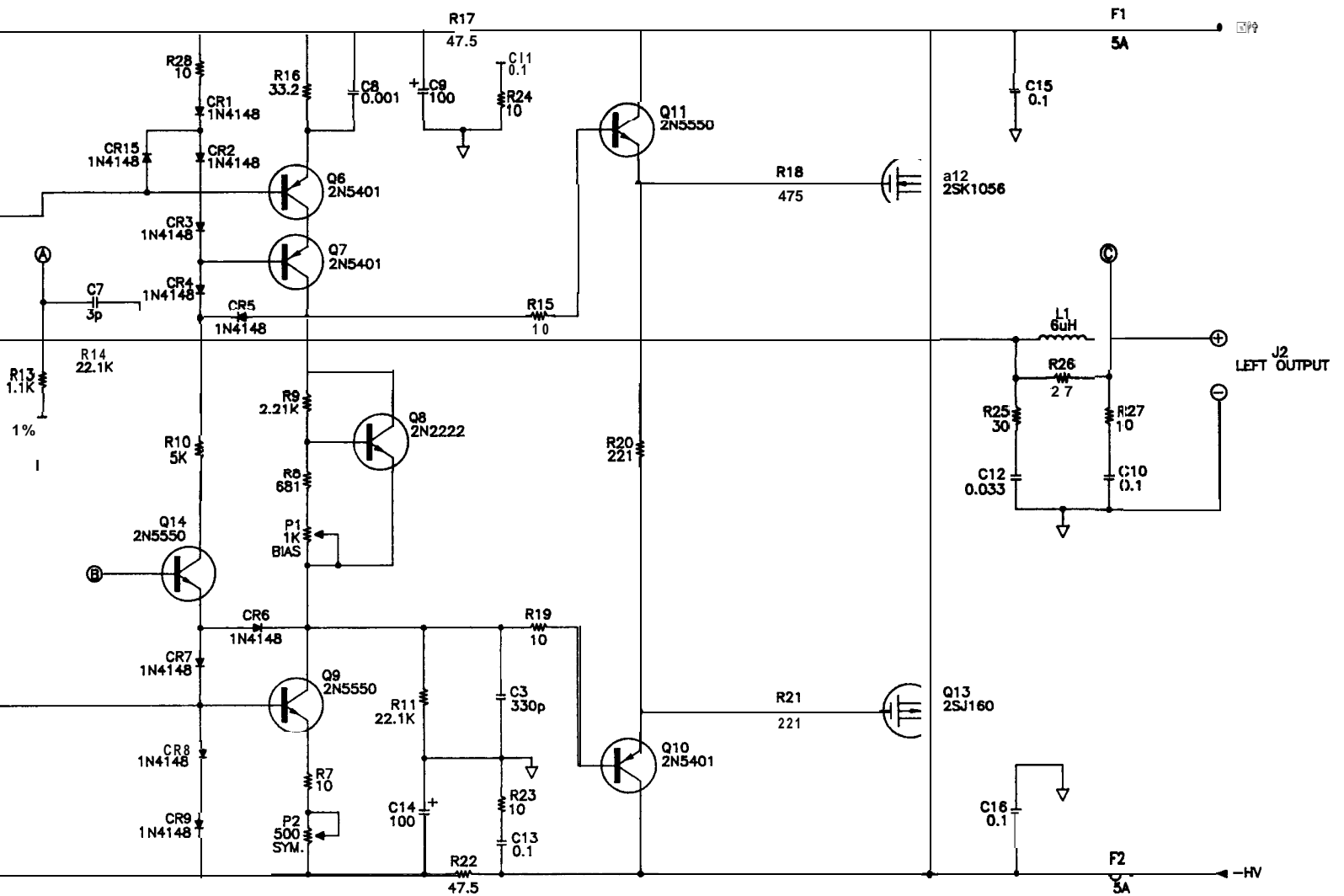

0 CIRCUIT SCHEMATIC DIAGRAM

REVISED 9/3/92

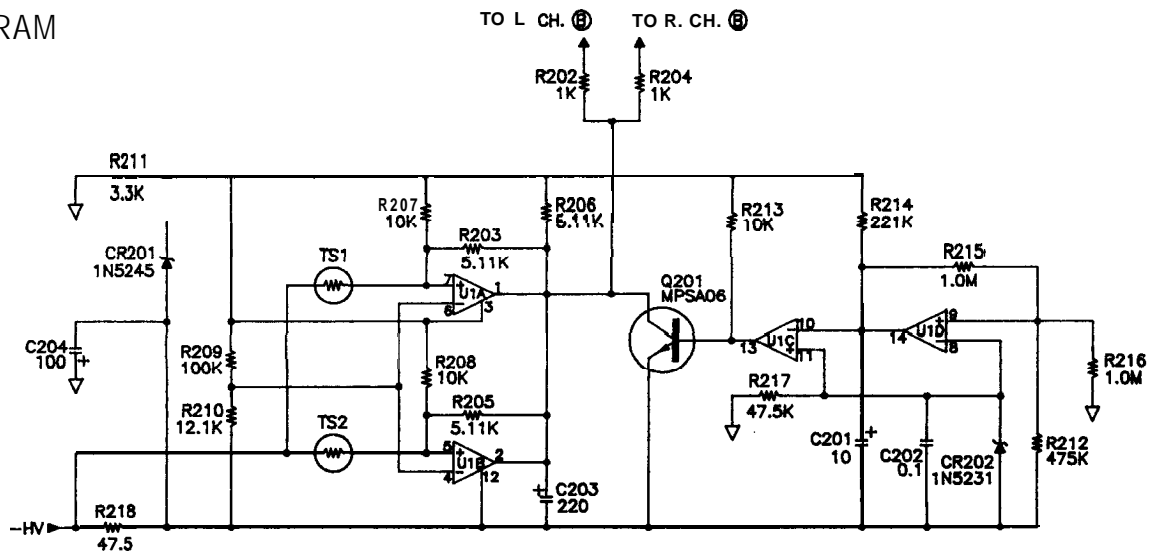

SERVICE POLICY AND LIMITED WARRANTY

If you encounter any difficulty or have any question concerning your 9130 Amplifier, please call our Customer Service Department weekdays, 8 a.m. to 3:30 p.m., Mountain Standard Time, at 602-967-3565.

Should you have any doubts as to whether the amplifier is malfunctioning and requires service, please call us before sending in for repair. All units being returned (regardless of warranty status) must receive a Return Authorization (RA) number. In addition, we can offer troubleshooting assistance that may simplify or even eliminate the need for factory service.

The Hafler 9130 Amplifier is warranted to the original owner (non-transferrable) for seven years from the date of purchase, including parts, labor, and return shipping costs within the Continental United States, Alaska, and Hawaii. This warranty applies only to products sold in the United States Of America.

For warranties outside the U.S.A., please contact your local agent.

It is the owner's responsibility to pay shipping (preferably United Parcel Service, UPS) to the factory: collect shipments will not be accepted. Units under warranty should be accompanied by a copy of the dated Bill Of Sale. Use the original carton and all packing material, with the RA number clearly marked on the outside of the package. Be sure to include a return address, the RA number, a daytime telephone number, and a brief description of the difficulty, including whether it occurs continuously or intermittently.

This warranty gives you specific legal rights. You may also have other rights which vary from state to state.