

The Harman-Kardon Model 100+

AM/Stereo FM Multichannel Receiver

Technical Manual

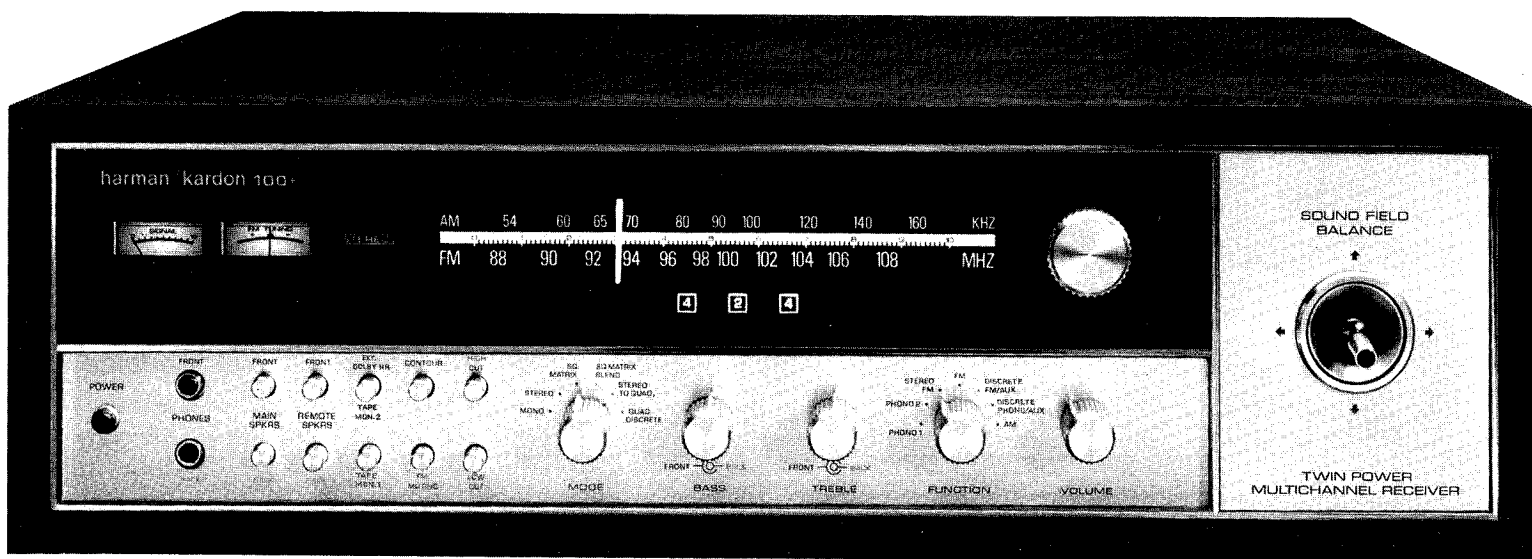

harman/kardon

ALIGNMENT PROCEDURES

AM IF AMPLIFIER ALIGNMENT PROCEDURE

INSTRUMENT: AM Generator (with Scope)

OUTPUT OF GENERATOR: Connect to TC5 (On V.C. — AM OSC) Terminal, Frequency = 455 KHz.

Adjust IFT51 and IFT52 as follows:
Adjust "B" for Maximum

NOTE: Generator Signal must be kept as low as possible to avoid A.V.C. action.

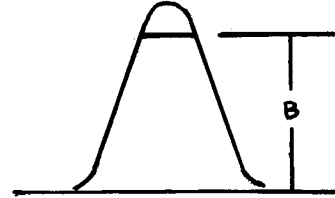

AM ALIGNMENT PROCEDURE

INSTRUMENT: AM Signal Generator, AC VTVM & Oscilloscope

NOTE: Set Function Switch to "AM"

Set Mode Switch to "MONO"

Set Volume Control to "MINIMUM"

Input Signal must be kept as low as possible to avoid A.V.C. action

Steps	Signal Generator		Tuning Dial Setting	VTVM & Scope Connection	Adjustment	Adjust for
	Coupling	Frequency				
1	The Test Loop about 60 cm (2 ft.) away from AM Bar (Loop Stick) Antenna	515KHz	Frequency Minimum	L Channel Tape Out Terminal	L52	Maximum Amplitude
2		1650KHz	Frequency Maximum		TC5	
*3						
4		600KHz (400Hz, 30% Modulation)	600KHz		L51 (Bar Ant)	
5		1400KHz (400Hz, 30% Modulation)	1400KHz		TC4	
*6						
7		1000KHz (400Hz, 30% Modulation)	1000KHz		VR52	0.225V (RMS) Output
8		Generator Output 0.1V			VR51	Signal Meter Full Scale
*3	Repeat Steps 1 and 2 until no further improvement is noticed.					
*6	Repeat Steps 4 and 5 until no further improvement is noticed.					

FM FRONT END ALIGNMENT PROCEDURE

INSTRUMENT: FM Signal Generator, AC VTVM & Oscilloscope

NOTE: Set Function Switch to "FM"

Set Mode Switch to "MONO"

Set Volume Control to "MINIMUM"

Input Signal must be kept as low as possible to avoid limiting point

Steps	Generator Connection	Generator Frequency	Tuning Dial Setting	VTVM & Oscilloscope Connection	Adjustment & Function	Adjust for
1	Connect FM Signal Generator to FM Ant Terminal	87MHz (400Hz, 75KHz DEVIATION)	Frequency Minimum	L, or R Channel Tape Out Terminal	L4 (FM OSC Coil)	Maximum Amplitude and Undistorted Sine wave on Oscilloscope
2		109MHz (400Hz, 75KHz DEVIATION)	Frequency Maximum		TC3 (FM OSC Trimmer)	
*3						
4		90MHz (400Hz, 75KHz Deviation)	90MHz		L1 (FM ANT Coil) L2 (FM RF Coil)	
5		106MHz (400Hz, 75KHz Deviation)	106MHz		TC1 (FM ANT Trimmer) TC2 (FM RF Trimmer)	
6	Repeat steps 4 and 5 until no further improvement is noticed.					
*3	Repeat steps 1 and 2 until no further improvement is noticed.					

FM IF AMPLIFIER ALIGNMENT PROCEDURE

INSTRUMENT: FM Signal Generator, FM Stereo Generator, AC VTVM, DC VTVM, Oscilloscope & Distortion Meter

NOTE: Set Function Switch to "FM"

Set Mode Switch to "MONO"

Set Volume Control to "MINIMUM"

The Front End Alignment must be completed.

GENERATOR CONNECTION: Connect FM Signal Generator to FM Ant Terminal

GENERATOR FREQUENCY: 98MHz (400Hz, 75KHz Deviation)

TUNING DIAL: 98MHz

AC VTVM, OSCILLOSCOPE & DISTORTION METER CONNECTION: L, or R Channel Tape Out Terminal

NOTE: All Readings indicated are at Generator

Steps	Input Signal Level	Adjustment Function	Adjust for
1	Must be kept as low as possible to avoid limiting point	Front End I.F.T. IF AMP I.F.T. IFT101 (Bottom Core)	Maximum Amplitude and Undistorted Sine Wave on Oscilloscope
2	At no input signal	IF AMP I.F.T. IFT101 (Top Core)	Center Tuning Meter Indicates Correct Center
3	100 μ V	IF AMP I.F.T. IFT101 (Bottom Core)	Distortion Minimum

STEPS 4: Oscilloscope Connection: FM Quad Terminal

Input Level: 100 μ V (Stereo Signal)

Adjust VR106 for Flat Base Line Composite MPX Signal

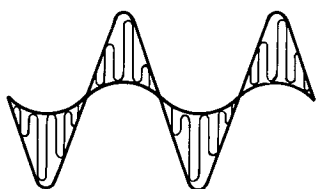

VR106 UNDER
COMPOSITE

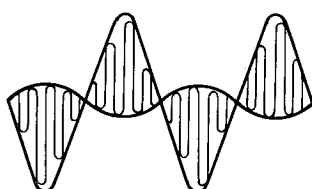

VR106 OVER
COMPOSITE

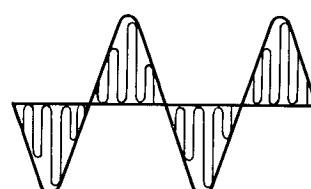

VR106 CORRECT

FM METER, MUTING, STEREO THRESHOLD ALIGNMENT PROCEDURE

INSTRUMENT: FM Signal Generator, FM Stereo Generator, AC VTVM, DC VTVM & Oscilloscope

NOTE: Set Function Switch to "FM STEREO"

Set Mode Switch to "STEREO"

Set Volume Control to "MINIMUM"

The FM Front End the FM IF Amplifier must be completed.

GENERATOR CONNECTION: Connect FM Signal Generator to FM Ant Terminal

GENERATOR FREQUENCY: 98MHz (400Hz, 75KHz Deviation)

TUNING DIAL SETTING: 98MHz

AC VTVM' OSCILLOSCOPE & DISTORTION METER CONNECTION: L, or R Channel Tape Out Terminal

FM Muting in OFF Position and Muting Threshold in CCW Position

Steps	Input Signal Level	Adjustment Function	Adjust for
1	Must be kept as low as possible to avoid limiting point	Front End I.F.T. IF AMP IFT101 (Bottom Core) Ratio Detector	Maximum Amplitude and Undistorted Sine Wave on Oscilloscope
2	Must be kept as low as possible to read signal meter deviation	IFT102	Signal Meter Maximum Deviation
3	10mV (10,000 μ V) (Non Modulation)	VR103	Signal Meter Indicates "10" Position
4	3.5 μ V (At This Time VR105 Is Maximum)	VR101	Muting Turn Off
5	10 μ V	VR105	Muting Turn Off
6	30 μ V (Stereo Signal)	VR102	Stereo Light Turn On

STEPS 7: Input Signal Level: 100 μ V

Tuning Dial Setting: 98MHz

Adjustment Function: VR104

Adjust for: Center Tuning Meter: That as you tune Above and Below Signal VR104 Sets Maximum Swing of Meter Left and Right as indicated by Points a and b below.

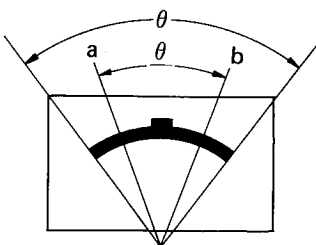

FM MPX STEREO ALIGNMENT PROCEDURE

INSTRUMENT: FM Signal Generator, FM Stereo Generator, AC VTVM, & Oscilloscope (High Impedance and Low Capacity Probe)

NOTE: Set Function Switch to "FM STEREO"

Set Mode Switch to "STEREO"

The FM Front End and FM IF Amp Alignment must be completed before attempting this FM MPX Stereo Alignment. Poor Front End and IF Alignment will result in Poor FM MPX Stereo Adjustment.

Steps	FM Stereo Generator		Output Indicator Connected to	Adjustment & Function	Adjust for
	Signal	Modulation			
1	Main Signal	100%	VTVM & Oscilloscope To Left Channel Tape Out Terminal	VR301	0.75V (RMS) Output
2	19KHz Pilot Signal Only	Less 5%	Probe Of Oscilloscope To Test Point	L301, L302 L303	Maximum Reading On Oscilloscope
3	Composite Signal To Left CH Only	Pilot 9% 100 % Left (Right)	VTVM & Oscilloscope To Left Channel Tape Out Terminal	L301	Maximum Amplitude And Undistorted Sine Wave On Oscilloscope
4	Composite Signal To Right CH Only				Minimum Reading Minimum Reading
5	19KHz Pilot Signal Only	5.5%		VR302	Stereo Light Turn On
6		Repeat Steps 3 – 4			

AUDIO DRIVER BIAS ADJUSTMENT

1. Set volume control to minimum position
2. Connect 8 ohm load resistor to speaker terminals in parallel.
3. Connect 20 mV DC millivolt master to LEFT FRONT (L_f) channel test point TP1 and TP2 (R765).
4. Adjust bias control VR751 until millivolt meter indicates 8 mV.
5. Repeat preceding steps for L_b , R_f , and R_b channel.

CHANGING THE STEREO/QUAD (4-CH) SWITCH

The receiver operates 24W x 4-CH when the switch is set QUAD (4-CH) side and 57.5W x 2-CH when the switch is set STEREO side at rated power.

The switch is set at QUAD (4-CH) side. If you want more output with stereo signal, please change the switch setting from QUAD (4-CH) side to STEREO side. To change the switch setting, remove the black screw at left side of the switch and remove the black plate for fitting the switch knob.

When the unit operates in STEREO mode, signal output comes only to LEFT FRONT and RIGHT FRONT speaker terminals (No signal at LEFT BACK and RIGHT BACK terminals).

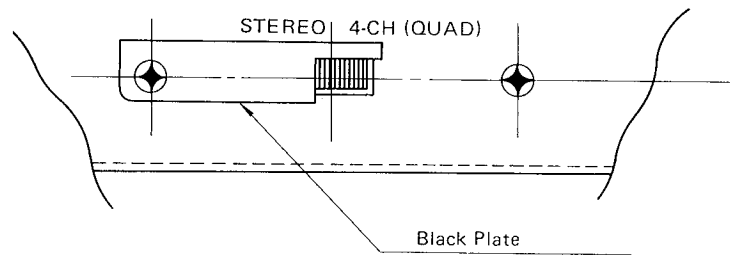

PHONO EQUALIZER BOARD

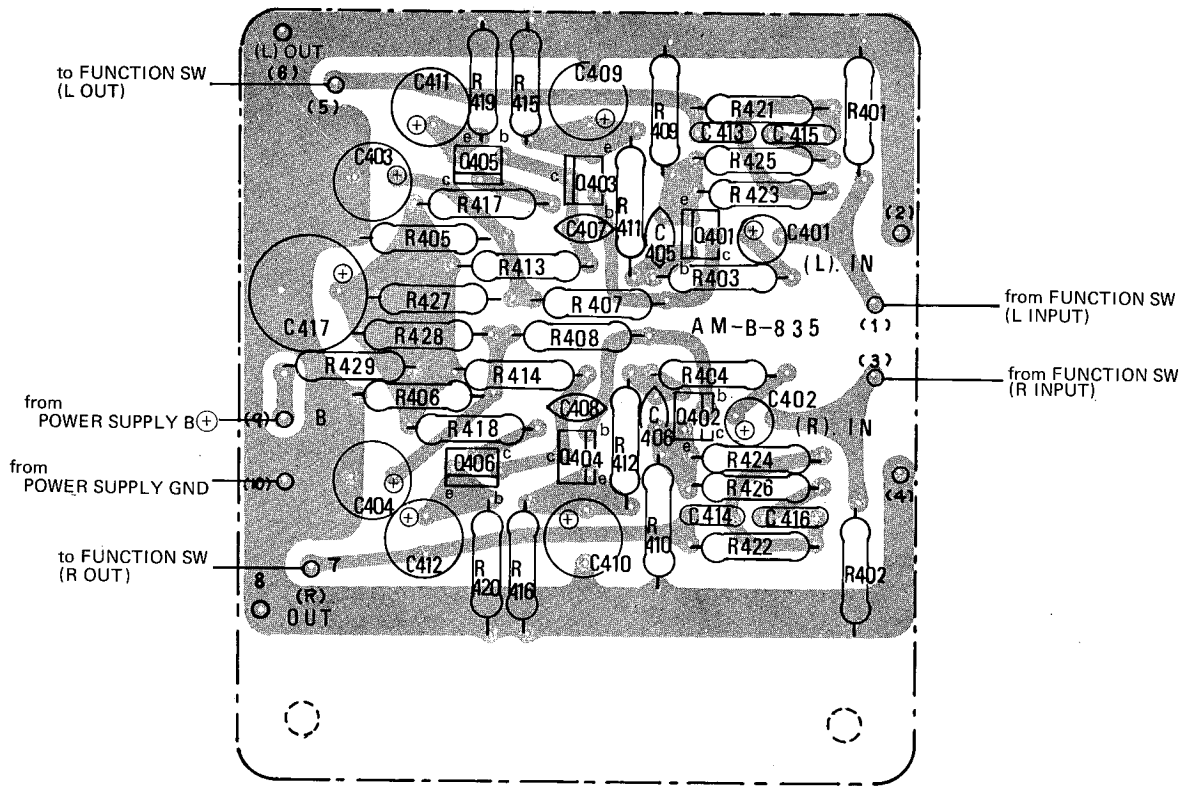

POWER AMP BOARD

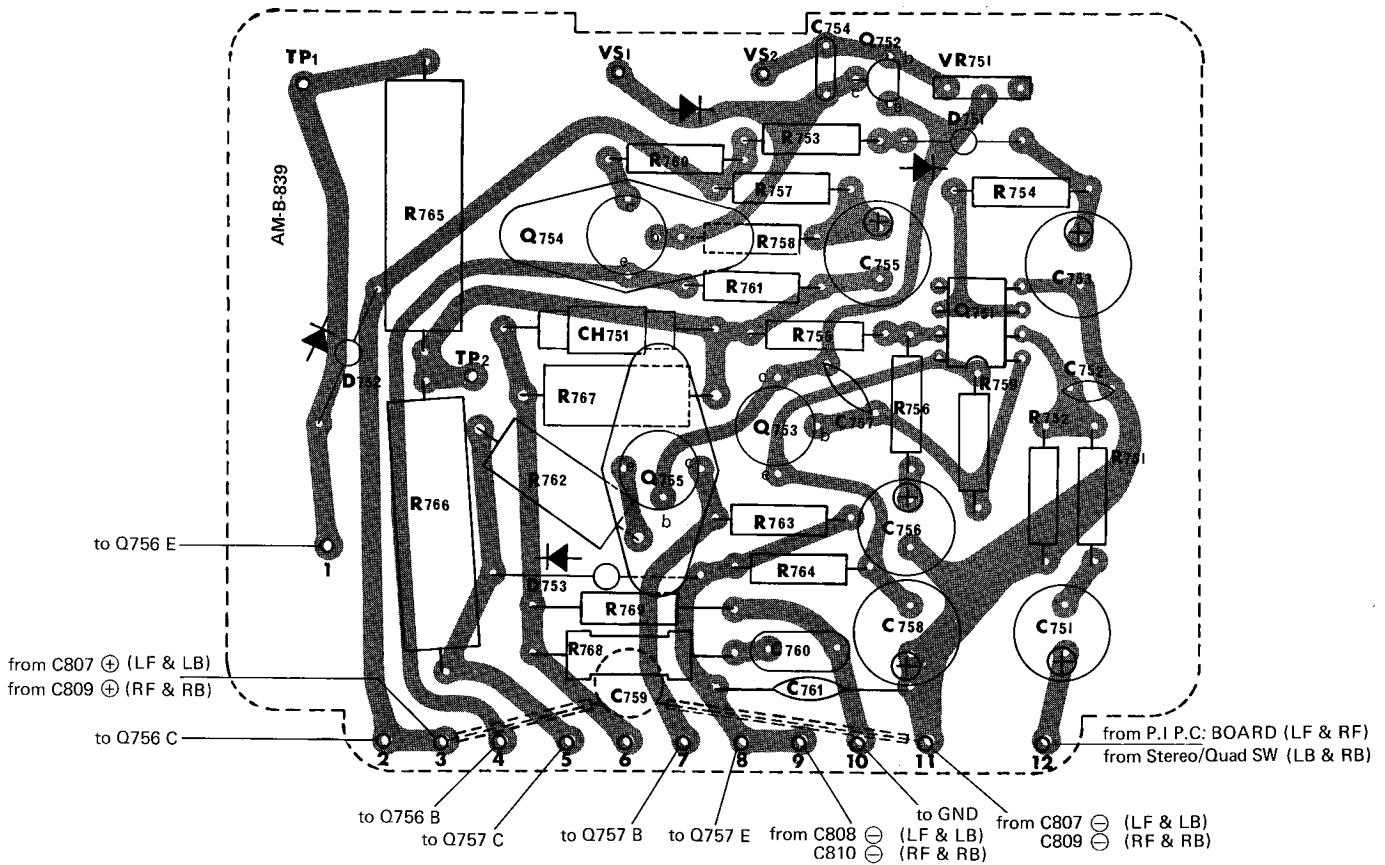

AM TUNER BOARD

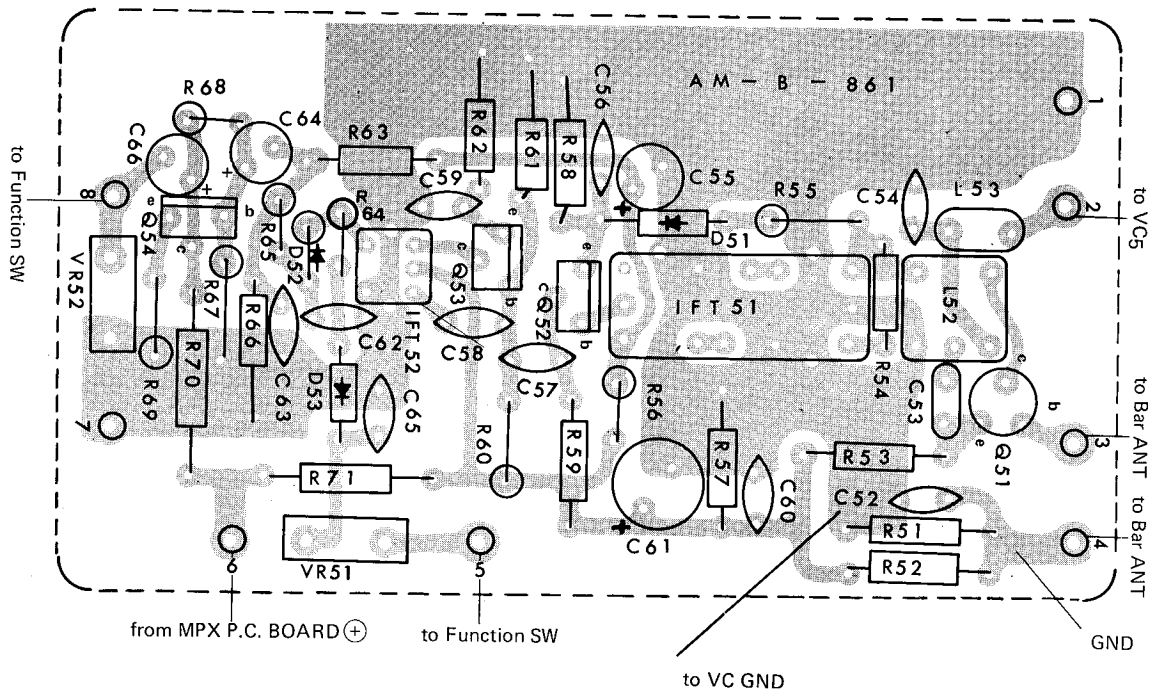

FM FRONT END BOARD

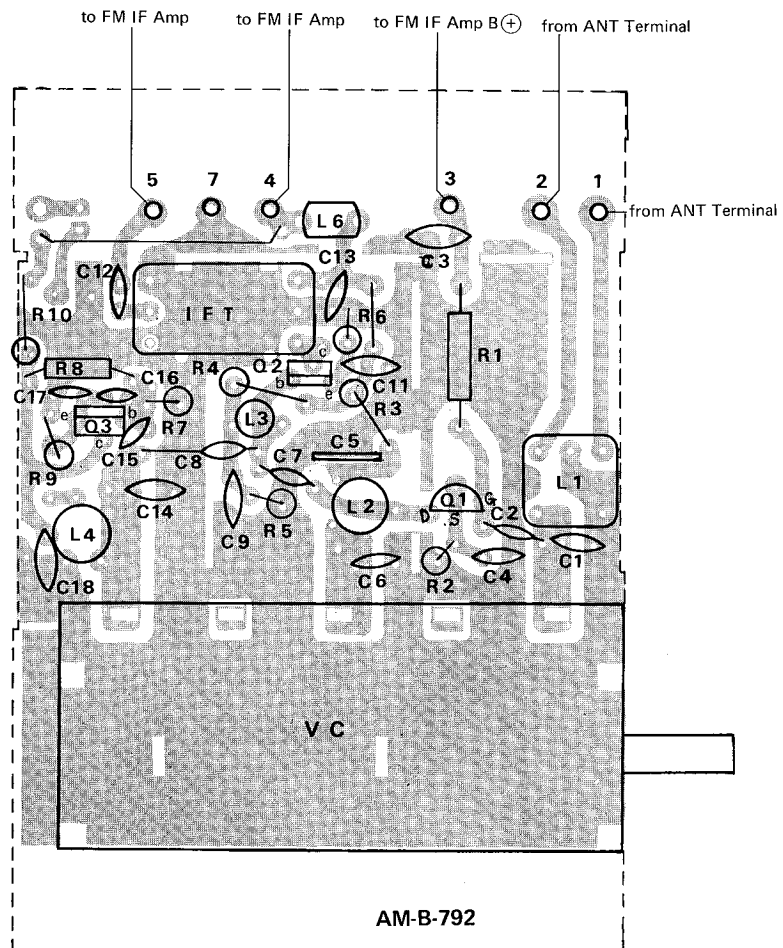

tone control board

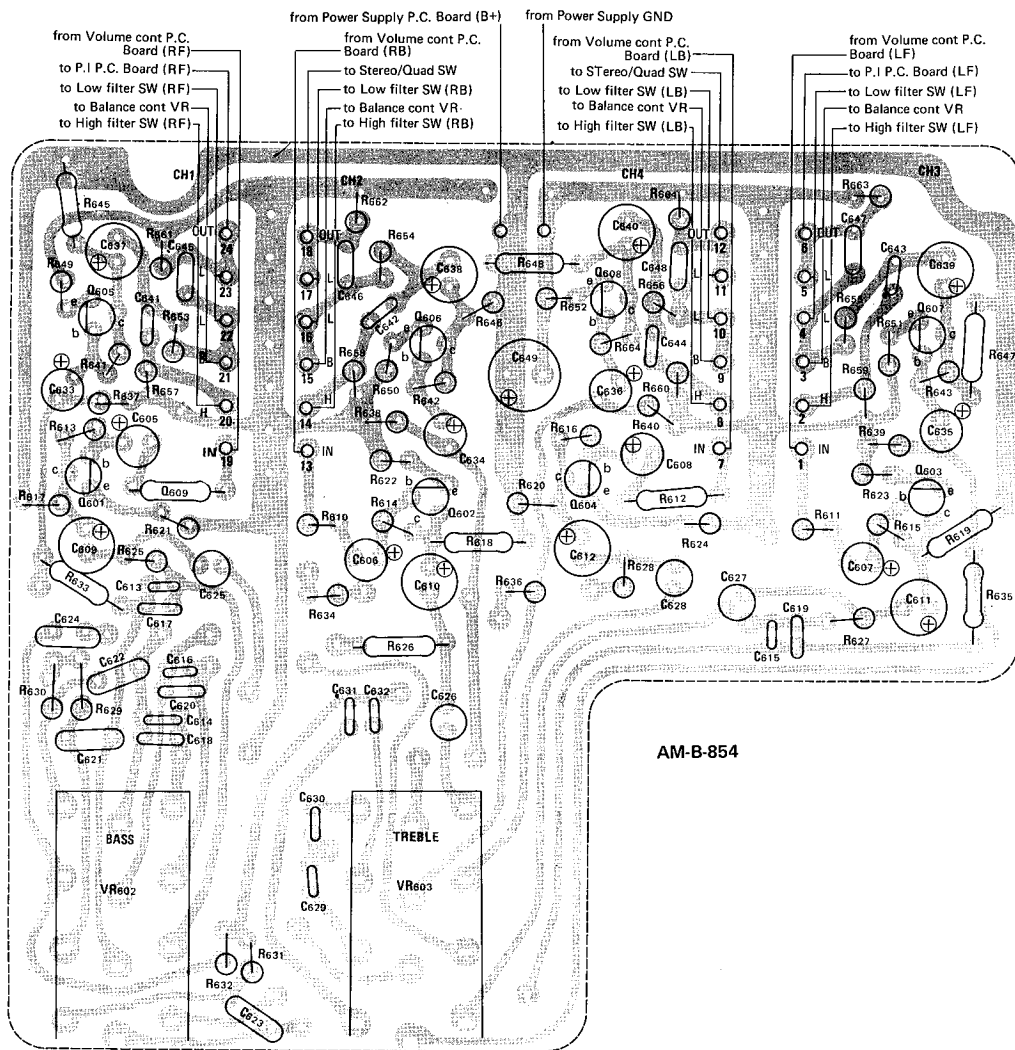

FM IF BOARD

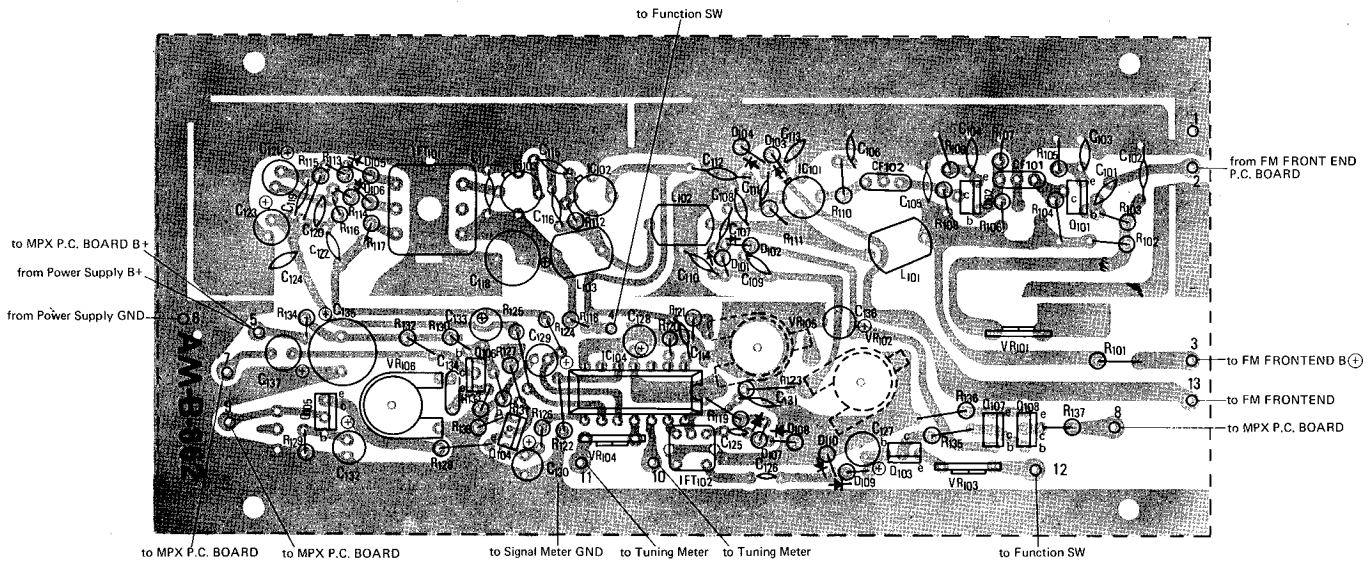

VOLUME CONTROL BOARD

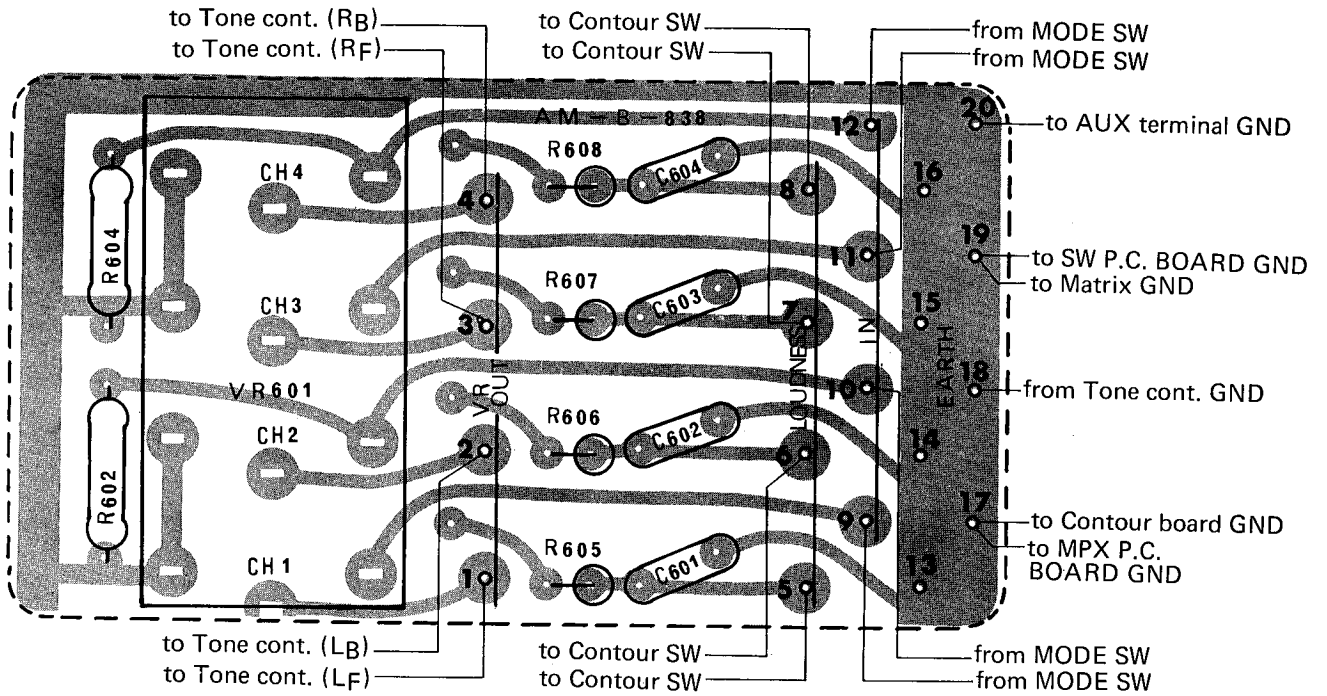

MPX BOARD

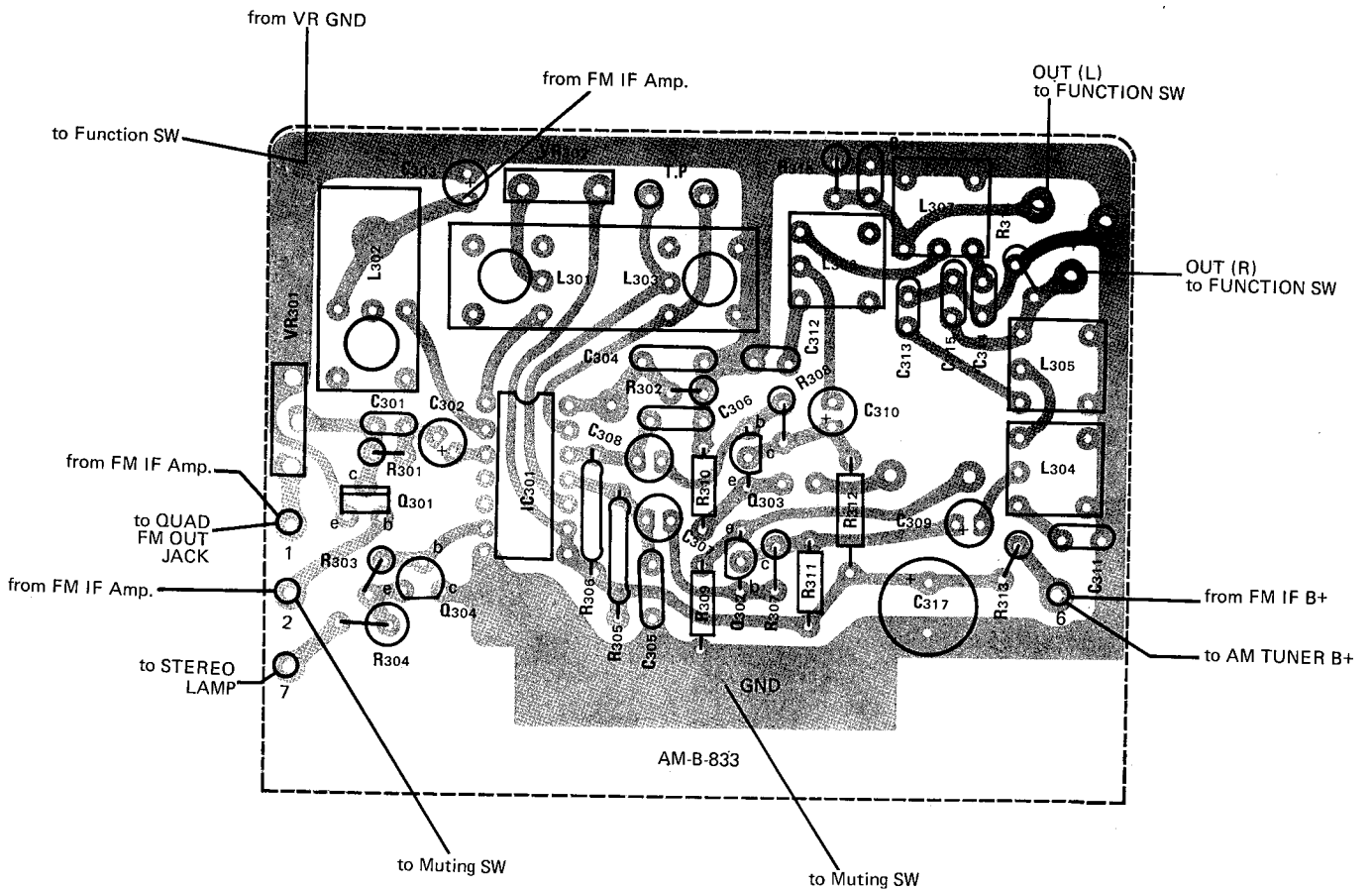

RECTIFIER BOARD

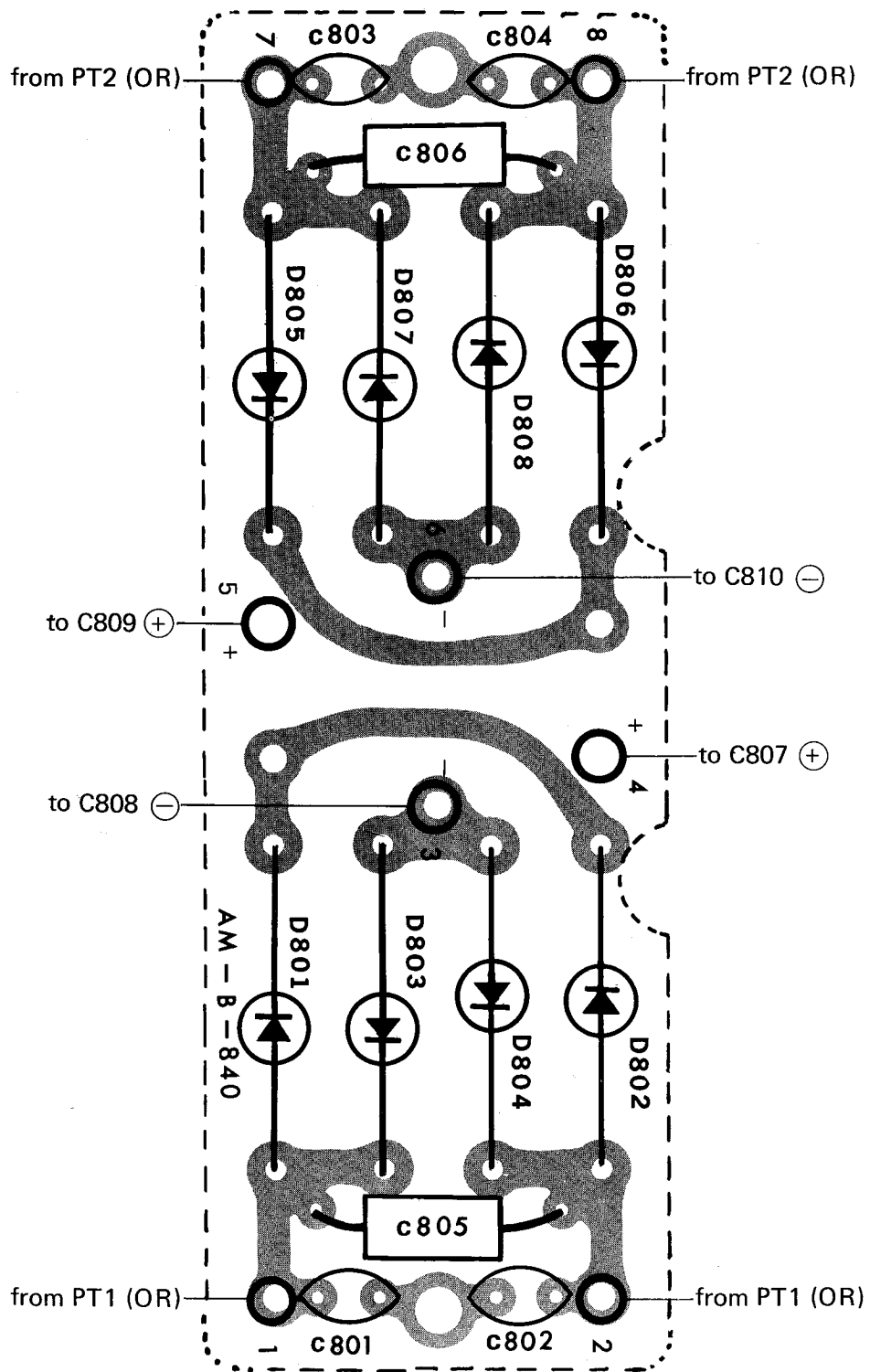

PHASE INVERTER BOARD

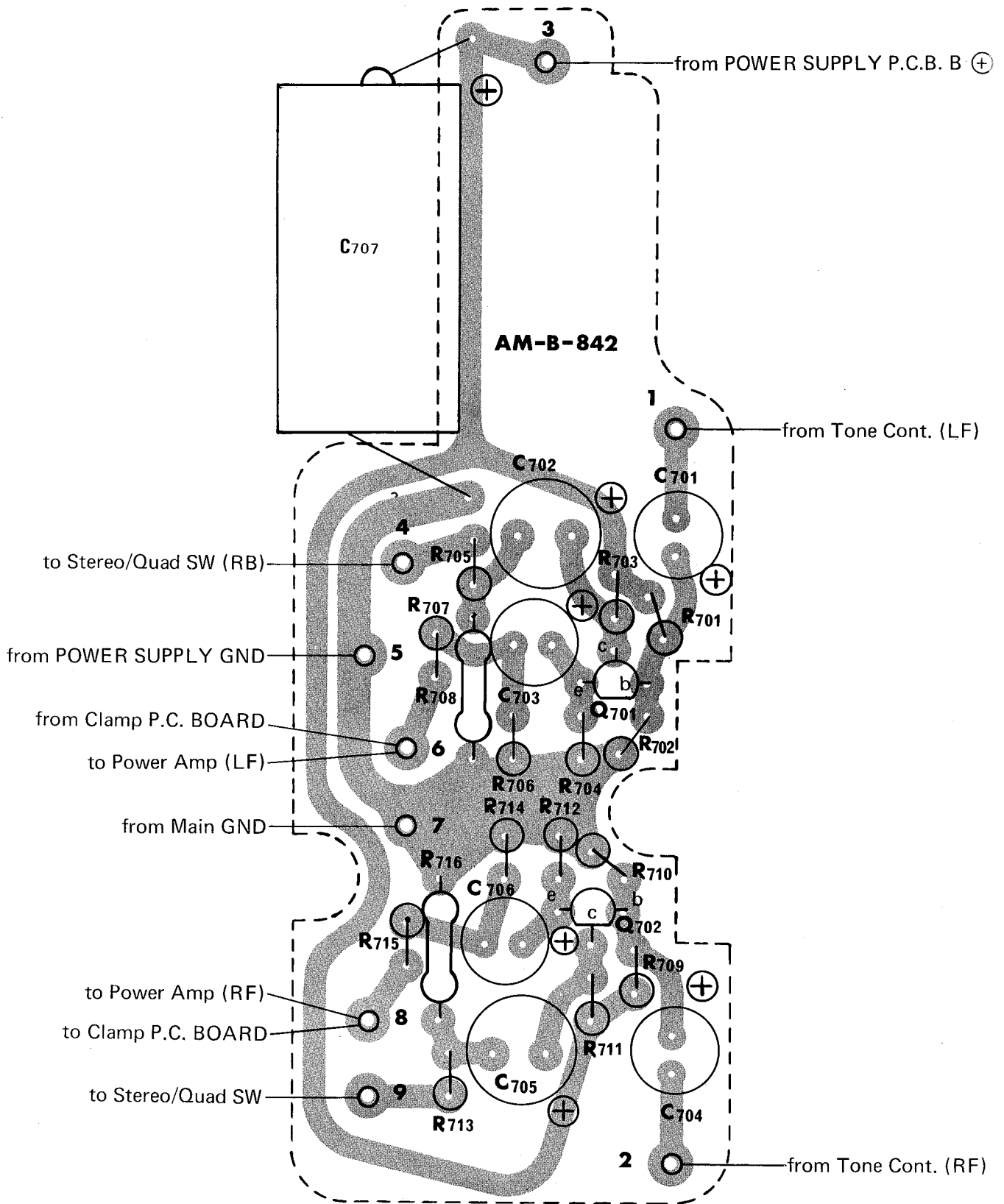

POWER SUPPLY BOARD

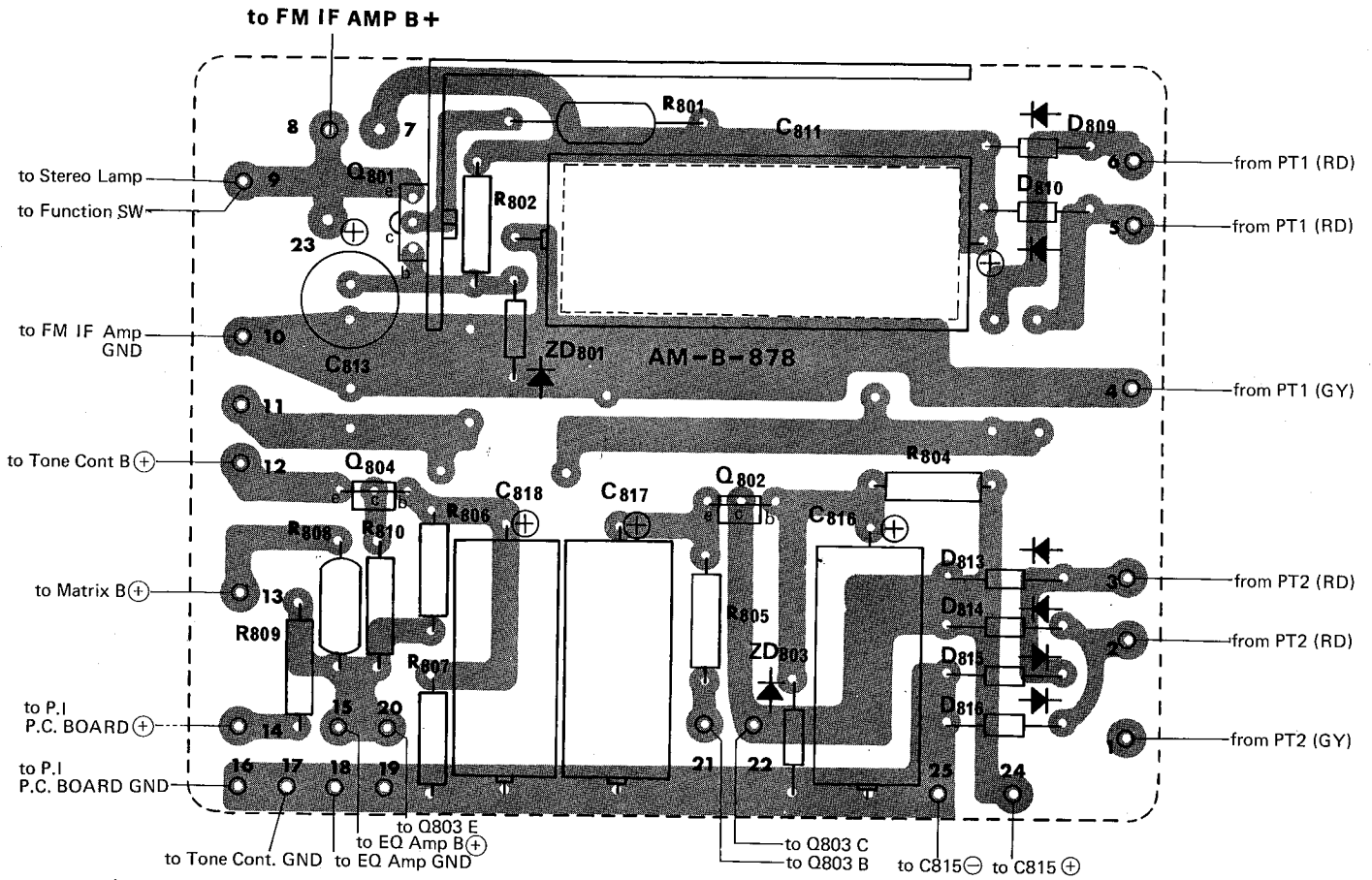

CLAMP BOARD

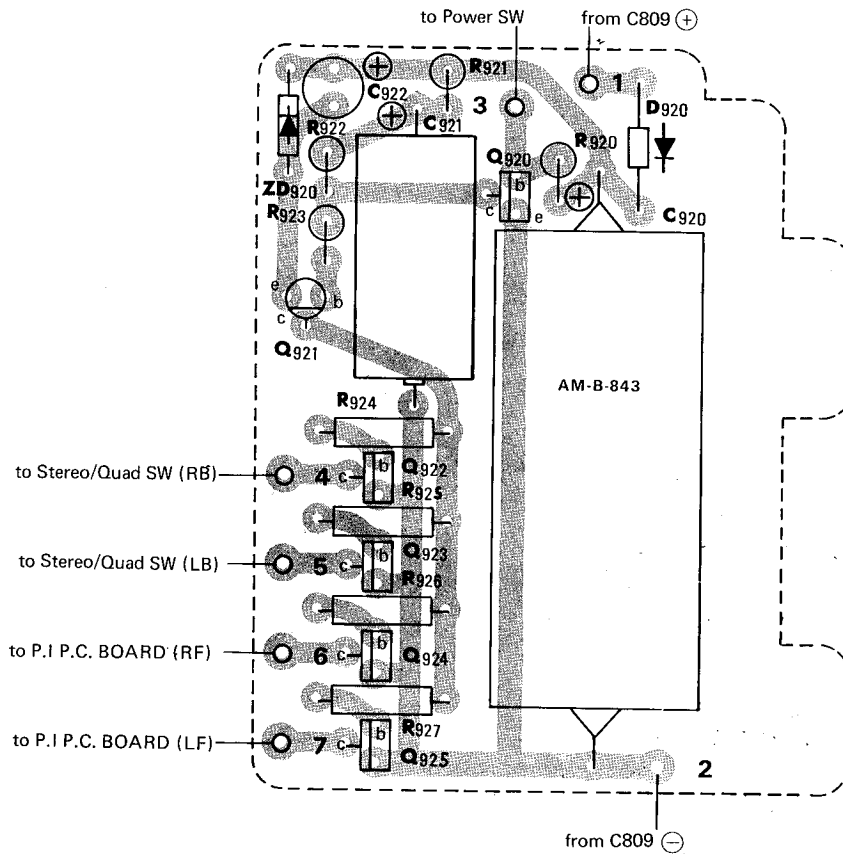

S.Q. MATRIX BOARD

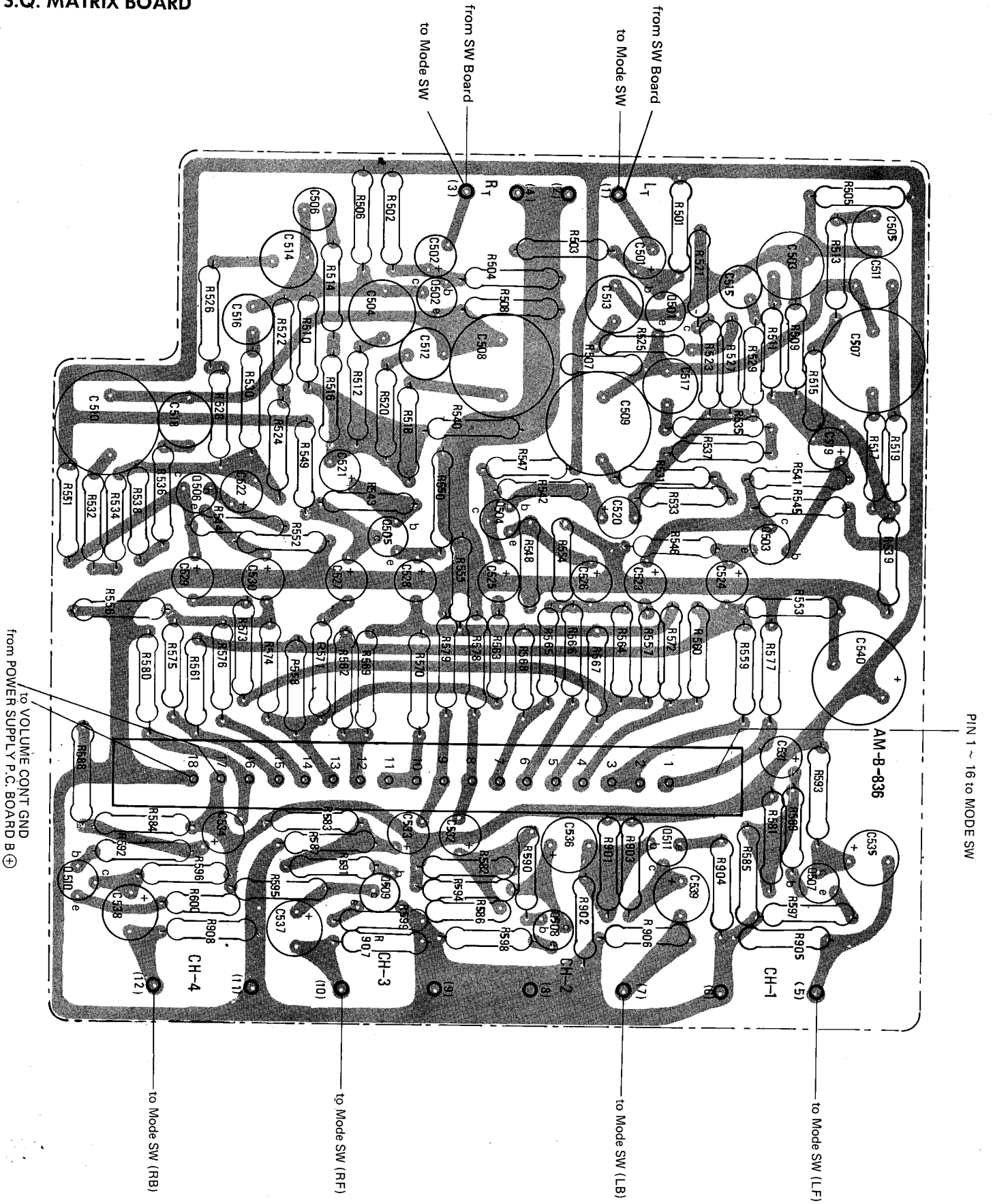

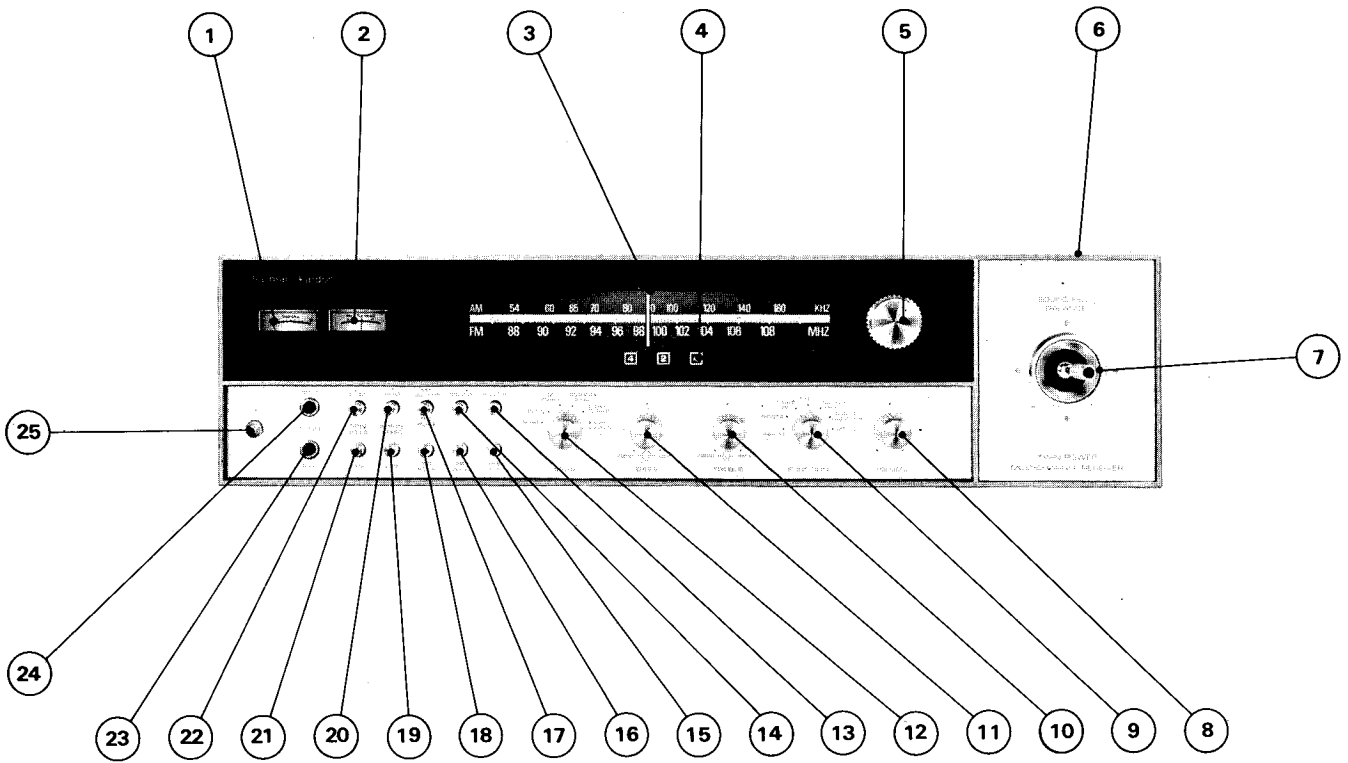

FRONT VIEW

- | | |
|------------------------------|------------------------------------|
| ① SIGNAL STRENGTH METER | ⑭ CONTOUR SWITCH |
| ② CENTER TUNING METER | ⑮ LOW CUT SWITCH |
| ③ POINTER | ⑯ FM MUTING SWITCH |
| ④ MODE LIGHT | ⑰ DOLBY NR (TAPE MONITOR 2) SWITCH |
| ⑤ TUNING KNOB | ⑱ TAPE MONITOR 1 SWITCH |
| ⑥ ESCUTCHEON | ⑲ BACK REMOTE SP SWITCH |
| ⑦ BALANCE VOLUME (JOY STICK) | ⑳ FRONT REMOTE SP SWITCH |
| ⑧ VOLUME CONTROL | ㉑ BACK MAIN SP SWITCH |
| ⑨ FUNCTION SWITCH | ㉒ FRONT MAIN SP SWITCH |
| ⑩ TREBLE CONTROL | ㉓ BACK PHONE JACK |
| ⑪ BASS CONTROL | ㉔ FRONT PHONE JACK |
| ⑫ MODE SWITCH | ㉕ POWER SWITCH |
| ⑬ HIGH CUT SWITCH | |

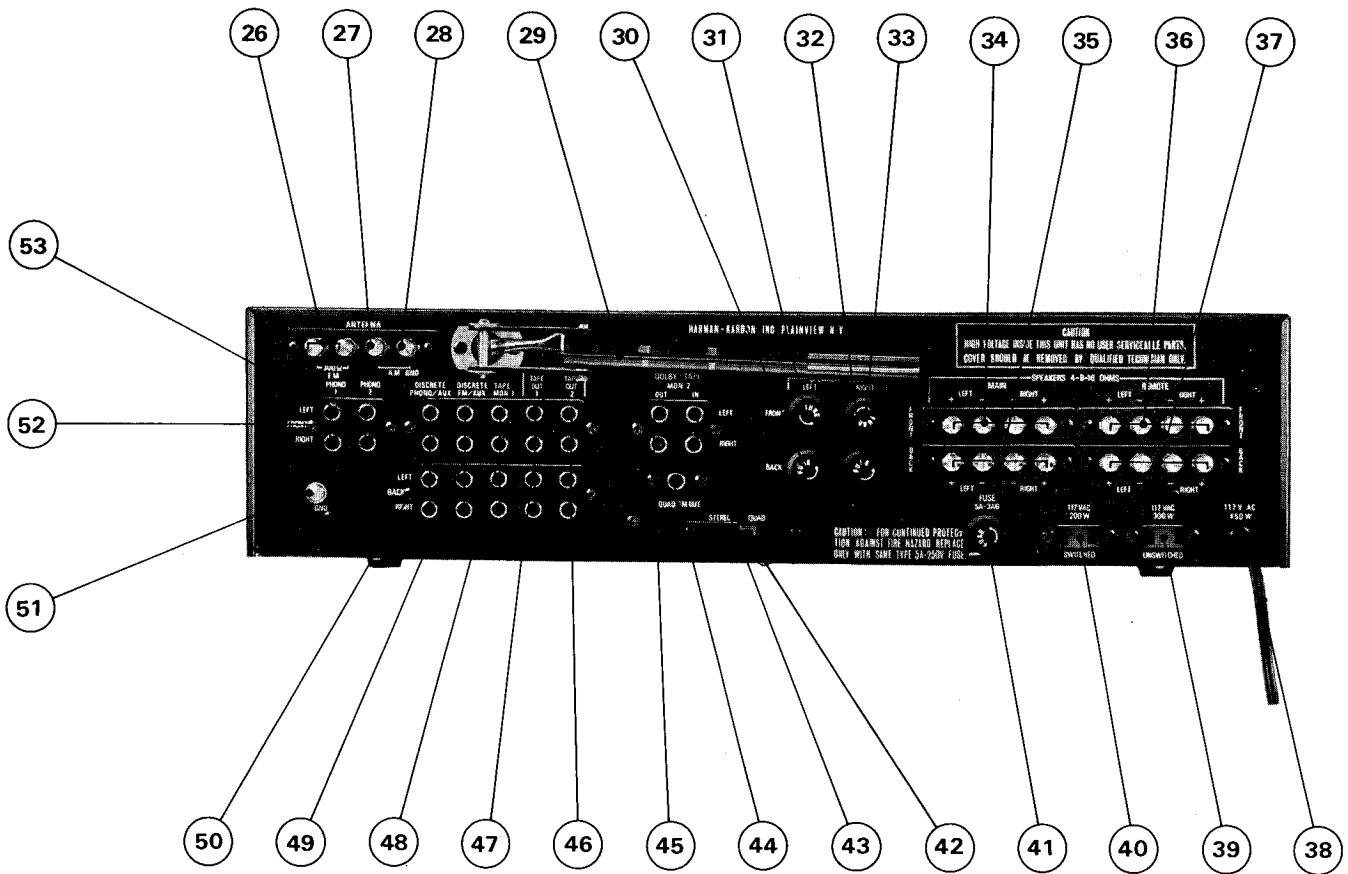

BACK VIEW

- | | |
|--------------------------------|----------------------------------|
| ②6 FM ANT TERMINAL | ④0 AC OUTLET (SWITCHED) |
| ②7 EXT AM ANT TERMINAL | ④1 AC LINE FUSE |
| ②8 ANT GND TERMINAL | ④2 STEREO/QUAD (4-CH) SWITCH |
| ②9 AM LOOP STICK ANTENNA (L51) | ④3 TAPE MONITOR 2 INPUT JACK |
| ③0 LEFT BACK SP FUSE | ④4 QUAD FM OUTPUT JACK |
| ③1 LEFT FRONT SP FUSE | ④5 TAPE MONITOR 2 OUTPUT JACK |
| ③2 RIGHT BACK SP FUSE | ④6 TAPE OUT 2 OUTPUT JACK |
| ③3 RIGHT FRONT SP FUSE | ④7 TAPE OUT 1 OUTPUT JACK |
| ③4 MAIN FRONT SP TERMINAL | ④8 TAPE MONITOR 1 INPUT JACK |
| ③5 MAIN BACK SP TERMINAL | ④9 DISCRETE FM/AUX INPUT JACK |
| ③6 REMOTE FRONT SP TERMINAL | ⑤0 DISCRETE PHONO/AUX INPUT JACK |
| ③7 REMOTE BACK SP TERMINAL | ⑤1 GND TERMINAL |
| ③8 AC LINE CORD | ⑤2 PHONO 1 INPUT JACK |
| ③9 AC OUTLET (UNSWITCHED) | ⑤3 PHONO 2 INPUT JACK |

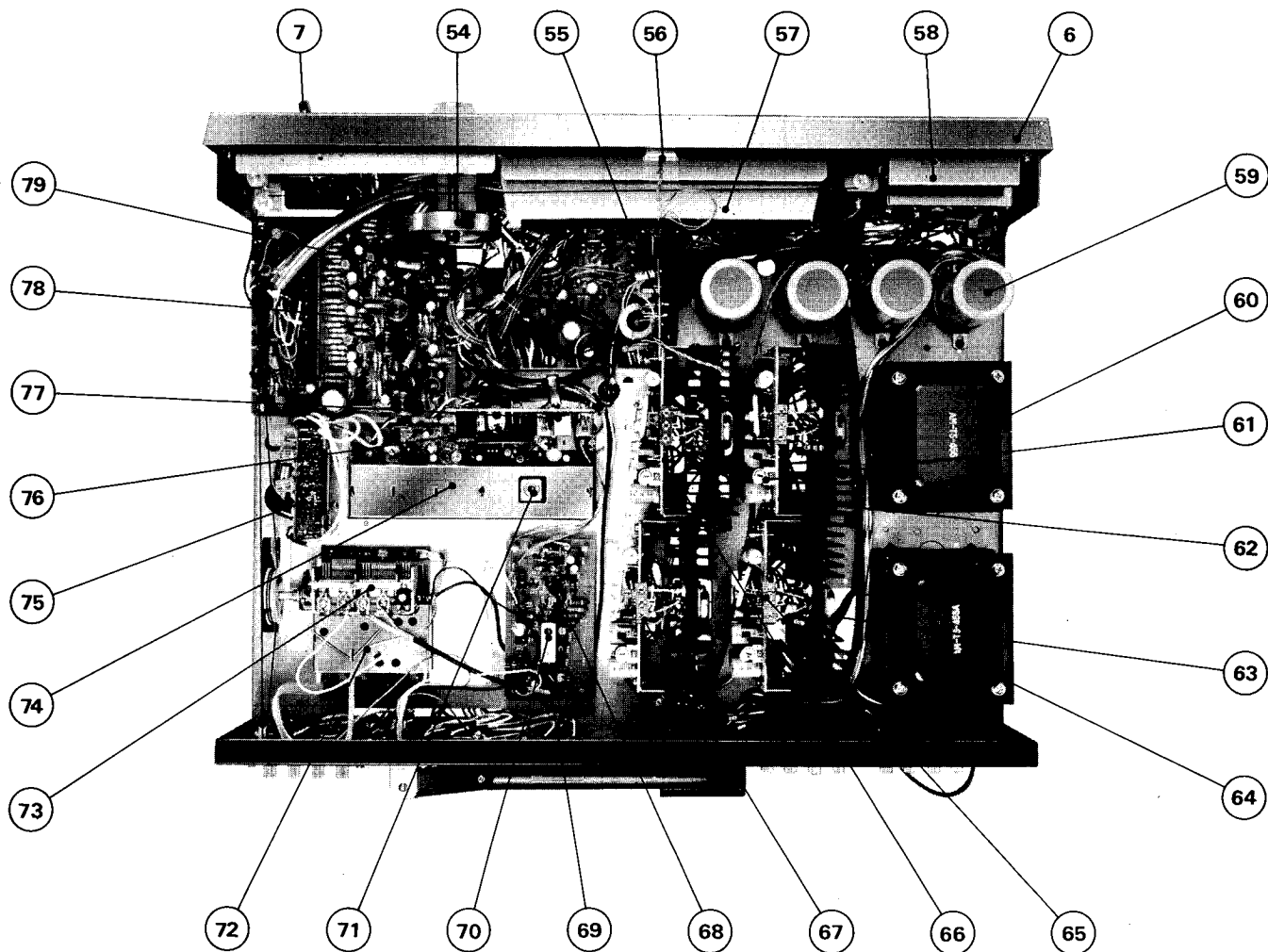

TOP VIEW

- | | |
|--|------------------------------|
| ⑤④ FLY WHEEL | ⑥③ POWER TRANSISTOR |
| ⑤⑤ CLAMP CIRCUIT P.C. BOARD | ⑥④ POWER TRANSFORMER 2 |
| ⑤⑥ POINTER LAMP HOUSE | ⑥⑤ POWER AMP P.C. BOARD (Rb) |
| ⑤⑦ DIAL LAMP HOUSE | ⑥⑥ POWER AMP P.C. BOARD (Lf) |
| ⑤⑧ METER LAMP HOUSE | ⑥⑦ POWER AMP P.C. BOARD (Lb) |
| ⑤⑨ RIPPLE FILTER CAPACITOR (C807-C810) | ⑥⑧ AM TUNER P.C. BOARD |
| ⑥① IDLING ADJ (VR751) | ⑥⑨ AM OSC COIL (L52) |
| ⑥② POWER AMP P.C. BOARD (Rf) | ⑦① AM I.F.T (IFT51) |
| | ⑦② FM I.F.T (IFT101) |

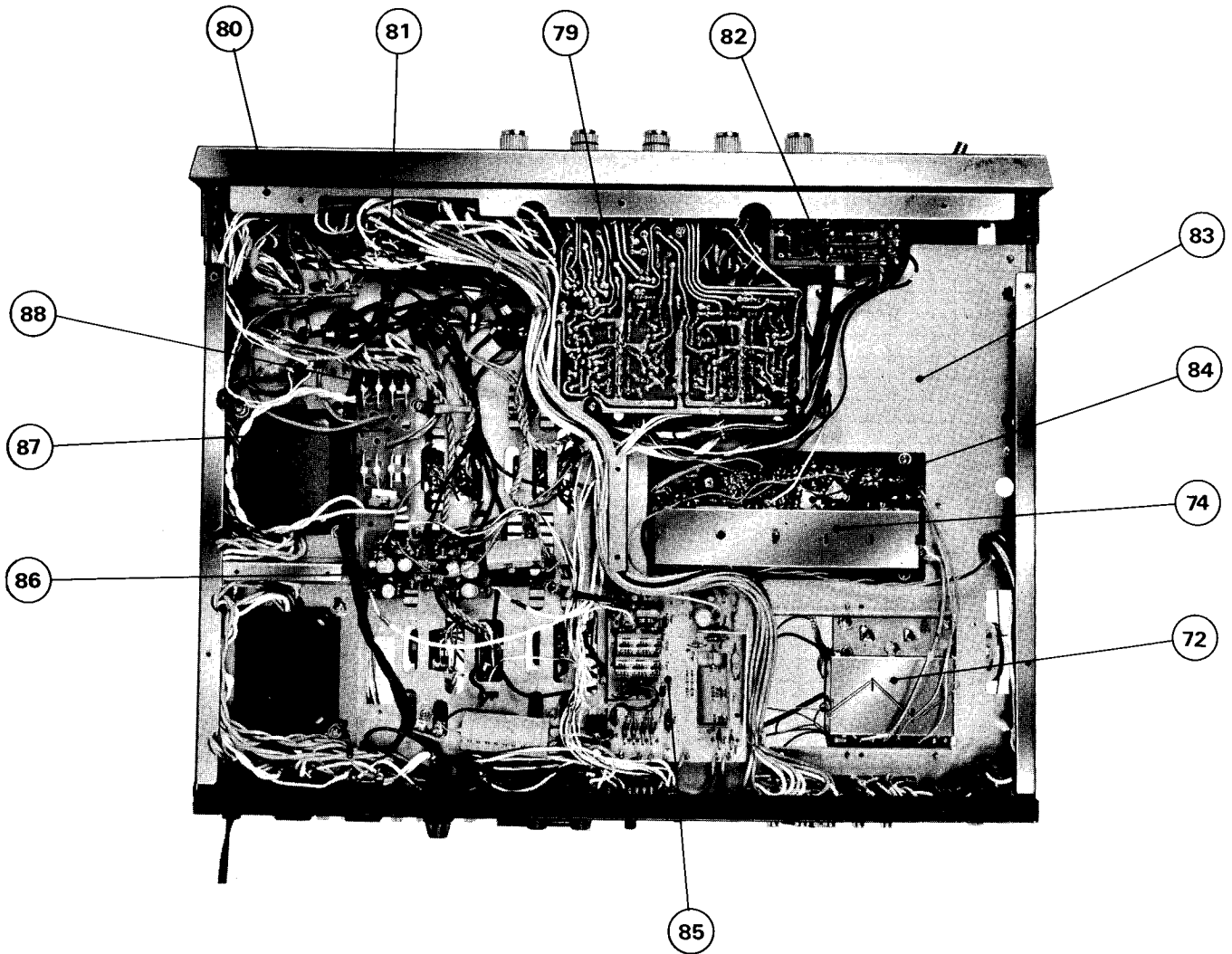

BOTTOM VIEW

- | | |
|-----------------------------|--------------------------------------|
| ⑦② FM FRONT END | ⑧① PUSH SWITCH P.C. BOARD |
| ⑦③ V.C | ⑧② VOLUME CONTROL P.C. BOARD |
| ⑦④ FM IF AMP P.C. BOARD | ⑧③ MAIN CHASSIS |
| ⑦⑤ PHONO PRE AMP P.C. BOARD | ⑧④ STEREO/MONO THRESHOLD ADJ (VR102) |
| ⑦⑥ 19kHz LEVEL ADJ (VR302) | ⑧⑤ VOLTAGE STABILIZER P.C. BOARD |
| ⑦⑦ MPX P.C. BOARD | ⑧⑥ PHASE INVERTER P.C. BOARD |
| ⑦⑧ MATRIX P.C. BOARD | ⑧⑦ RECTIFIER P.C. BOARD |
| ⑦⑨ TONE AMP P.C. BOARD | ⑧⑧ RECTIFIER (D801-D808) |
| ⑧① FRONT CHASSIS | |

STRINGING DIAGRAM

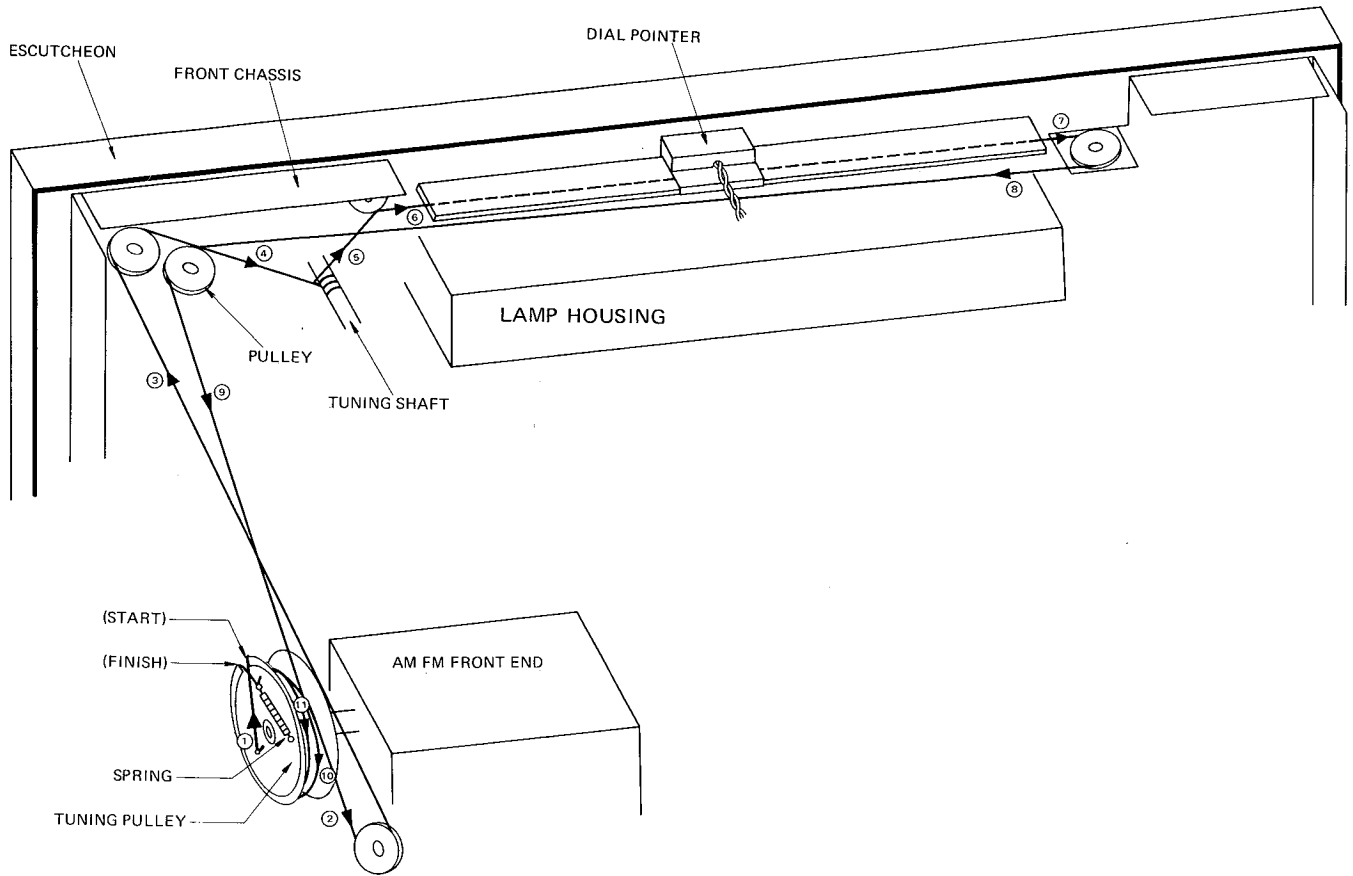

REPLACEMENT PARTS LIST

HK PART NO.	REF. NO.	DESCRIPTION	HK PART NO.	REF. NO.	DESCRIPTION
TRANSFORMERS			DIODES		
11029041	IFT	Transformer, IF 10.7Hz	41029290	D101-110	Diode,IN60
11029042	IFT 101	Transformer, IF 13mm	41029015	D752,753	Diode, V063
11029281	IFT 102	Transformer, IF 7mm	41028522	D751,920	Diode, W06A
10129067	T1, T2	Power Transformer	41029014	D801-808	Diode, 3A200
COILS			42029017	ZD801	Diode, Zener,WZ162
12029046	L6,53,101,103	Choke Coil (EL9530-2RZK)	42029018	ZD803	Diode,Zener,WZ310
12029068	L3	Choke Coil (0.74 μ H)	42029296	ZD920	Diode,Zener,RD5A
12029069	L4	Oscillating Coil (2 $\frac{1}{4}$ T)	CONTROLS & SWITCHES		
12029070	L2	Tuning Coil (2 $\frac{1}{4}$ T with CT)	23028993	VR602	Control,Bass,100K Ohm
12029071	L1	Antenna Coil (300 Ohm)	23028994	VR603	Control,Treble,200K Ohm
12029050	L102	Choke Coil (15H)	23028992	VR601	Control,Volume,100K Ohm
12029058	L302	Tuning Coil	00229000	VR605	Control,Balance 50K "W" Type
12029057	L301, 303	Tuning Coil	23529369	VR51	Pot,2K Ohm "B" Type
12029053	L304, 306	Tuning Coil	23528284	VR52	Pot,50K Ohm "B" Type
12029054	L305, 307	Tuning Coil	23528998	VR101	Pot,10K Ohm "B" Type
12029282	L51	BAR Antenna Coil	23529285	VR102	Pot,500 Ohm "B" Type
12029283	L52	AM Oscillating Coil	23529370	VR103	Pot,5K Ohm "B" Type
TRANSISTORS & IC'S			23529286	VR105	Pot,20K Ohm "B" Type
43027722	Q51	Transistor (2SA1023A)	23529287	VR104,106	Pot,20K Ohm "B" Type
43025972	Q52,101,102	Transistor (2SC460CM)	23529288	VR302	Pot,500 Ohm "B" Type
43025972	Q53	Transistor (2SC460BM)	23529004	VR301	Pot,50K Ohm "B" Type
43025972	Q54	Transistor (2SC458BM)	23529289	VR751	Pot,5K Ohm "B" Type
43025972	Q103-105,107 108	Transistor (2SC458BM)	23528726	S14	Switch, AC
43025972	Q106	Transistor (2SC458LGCM)	25029006	S2,4,6,8,10	Switch Bank, Top (5)
43025972	Q301	Transistor (2CS454CM)	25029007	S3,5,7,9,11	Switch Bank, Bottom (5)
43025972	Q302,303,802	Transistor (2SC945Q)	24029775	S13	Switch, Function (Rotary)
43027722	Q304	Transistor (TSC9002-3C)	24029542	S12	Switch, Mode (Rotary)
43027872	Q401,402	Transistor, Power (2SC458LGCM)	24529532	S1	Switch, Slide
43025972	Q403,406,804	Transistor (2SC458CM)	MISCELLANEOUS		
43025972	Q701,702	Transistor (2SC945P)	00229297	VC	AM/FM Tuner
38129008	VS751	Varistor (HV-46 (red))	63029298		Escutcheon
43025972	Q752	Transistor (2SC945Q)	63029020		Gold Insert, Joystick Area
43026284	Q753	Transistor (2SC959L)	63029299		Gold Insert, Control Area
43026284	Q754	Transistor (2SC960L)	61629300		Tinted Glass Panel
43026285	Q755	Transistor (2SA607L)	63028705		Dress Ring—Joystick
43024216	Q756,757	Transistor (2SD322K)	61029301		Dial Scale
43027722	Q758,759	Transistor (2SC640 (P,Q,R))	63228078		Knob,Balance Control
43027722	Q921	Transistor (2SA608)	63229536		Knob,Volume, Function
43025972	Q920,922-925	Transistor (2SC458)	63229535		Knob (Front),Bass,Treble
43128741	IC101-103	IC(LA1221)	63229534		Knob (Back),Bass,Treble
43129302	IC104	IC(TA7106P)	63228699		Knob,Tuning
43126551	IC301	IC(MC1307P)	63228700		Knob,Pushbotton,Alum
			63228979		Knob,Power Switch (Red)
			46528980	LA301	Bulb,15V-70MA (Stereo)

HK PART NO.	REF. NO.	DESCRIPTION
MISCELLANEOUS (cont.)		
46528981	LA010,011	Bulb,10V-150MA
46528982	LA001,002-005	Bulb,Power,Mode (1-4-2-4)
46528980	LA014	Bulb,10V-70MA (Dial Point)
46528903	LA006-009	Bulb,10V-300MA
60728984		Dial Pointer
00228709		Flywheel/tuning Shaft Assy.
65429533	J30,31	Jack, Headphone
65428716	Fuse 1 to 5	Fuseholder, SN1301
45028865	Fuse 1 to 4	Fuse, 5 Amp-3AG
45029279	Fuse 5	Fuse, 4 Amp
65428719	Outlet 1-2	Outlet,AC
00228986	L51	AM Loopstick Assy. W/Mtg Bracket

HK PART NO.	REF. NO.	DESCRIPTION
MISCELLANEOUS (cont.)		
65428989	J1,2,15,16,8, 9,22,23	Receptacle, 10 Pin (RCA Type)
55428988	J3-7,10-14 17-21,24-28	Receptacle, 4 Pin (RCA Type)
65428937	J29	Receptacle, 1 Pin (RCA Type)
65428990	TM1-TM20	Terminal, Am/Speaker
60128904		Top Cover
12529291	M102	Signal Meter, 250 μ A
12529292	M101	Tuning Meter, \pm 125 μ A
90728283		Power Cord (UL)
90129234		Carton & Fillers
90729295		Schematic, 100+
62028695		Mounting Feet

NOTE: To speed handling of your order be sure to include both the model and serial numbers which appear at the back of the chassis, in addition to the quantity, part number and part description of the items ordered. Orders from independent dealers, independent servicemen, and retail customers will be shipped on a cash in advance basis. Harman-Kardon reserves the right to substitute equivalent parts for those originally installed in this chassis. All parts should be ordered from Harman-Kardon, 55 Ames Court, Plainview, L.I., N.Y. 11803, Att: Parts Department.

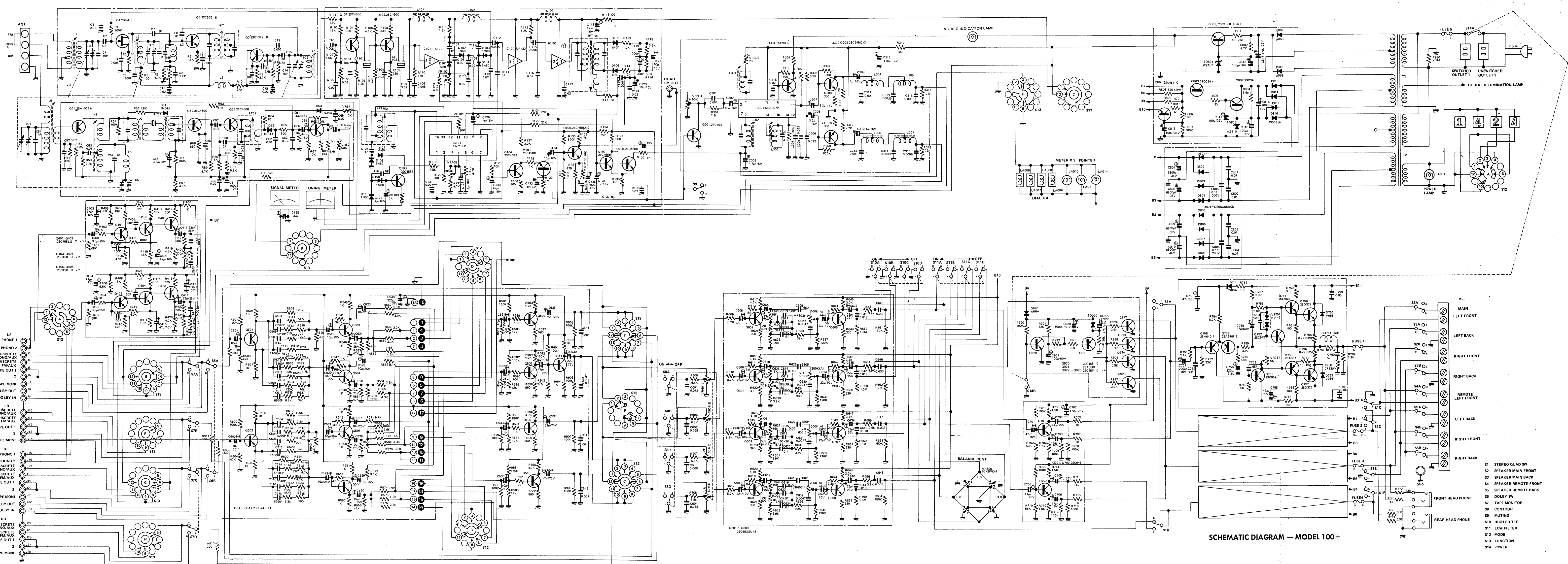

SCHMATIC DIAGRAM — MODEL 100+

- S1 STEREO QUAD SW
- S2 SPEAKER MAIN FRONT
- S3 SPEAKER MAIN BACK
- S4 SPEAKER REMOTE FRONT
- S5 SPEAKER REMOTE BACK
- S6 DOLBY SW
- S7 TAPE MONITOR
- S8 CONTOUR
- S9 MUTING
- S10 HIGH FILTER
- S11 LOW FILTER
- S12 MODE
- S13 FUNCTION
- S14 POWER

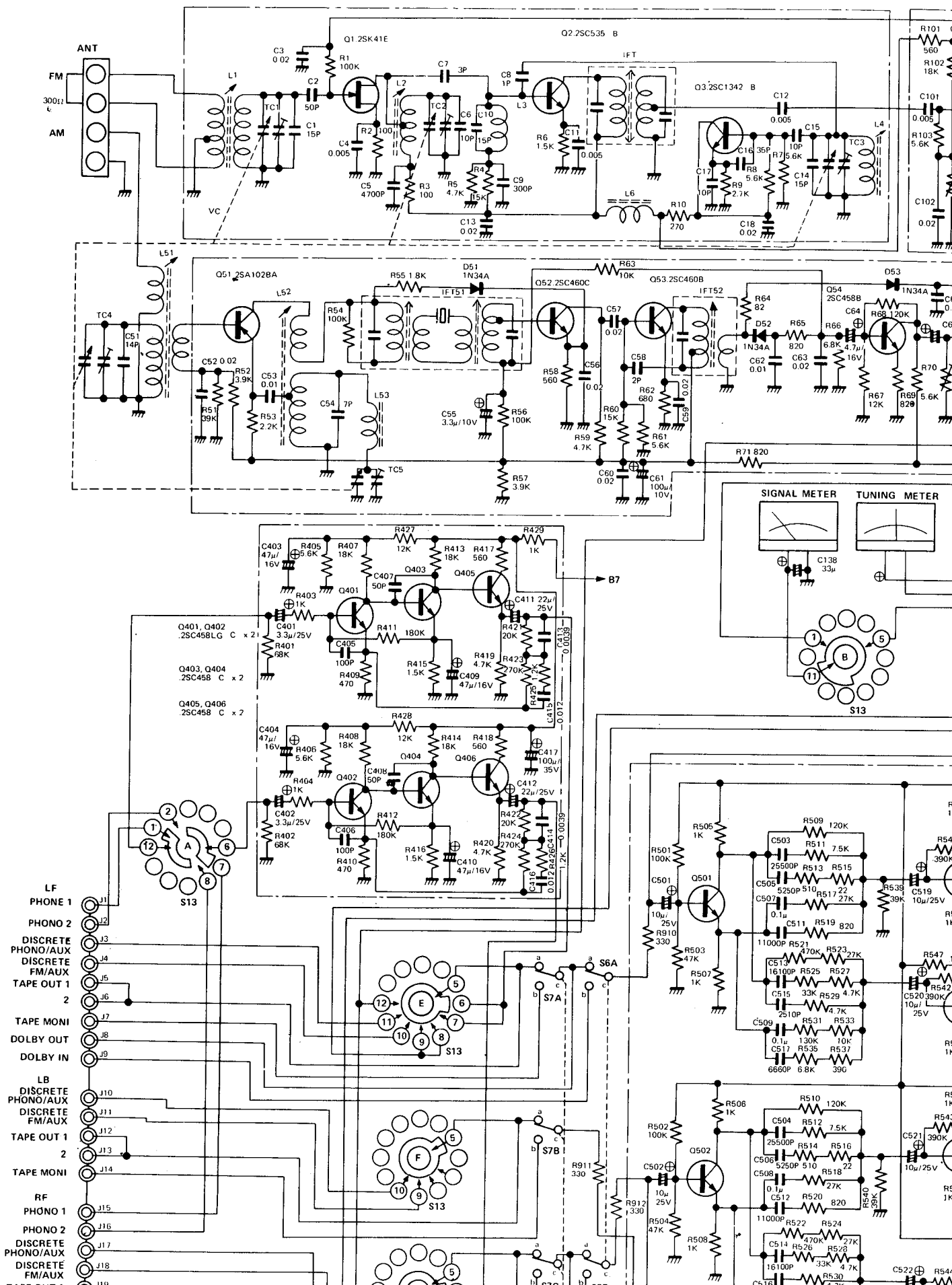

- LF PHONE 1
- PHONO 2
- DISCRETE PHONO/AUX
- DISCRETE FM/AUX
- TAPE OUT 1
- 2
- TAPE MONI
- DOLBY OUT
- DOLBY IN
- LB DISCRETE PHONO/AUX
- DISCRETE FM/AUX
- TAPE OUT 1
- 2
- TAPE MONI
- RF PHONE 1
- PHONO 2
- DISCRETE PHONO/AUX
- DISCRETE FM/AUX
- TAPE OUT 1

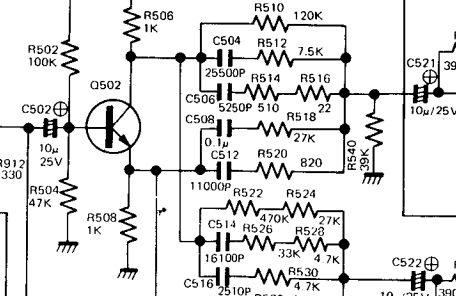
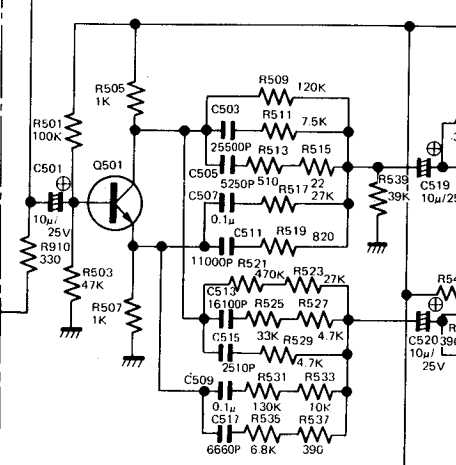
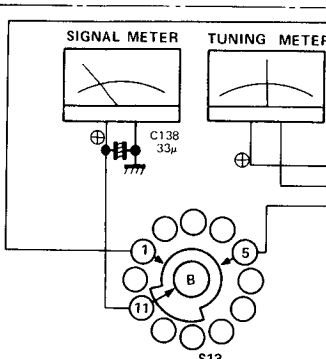
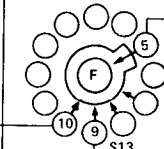
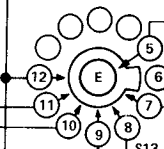
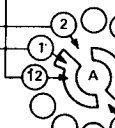

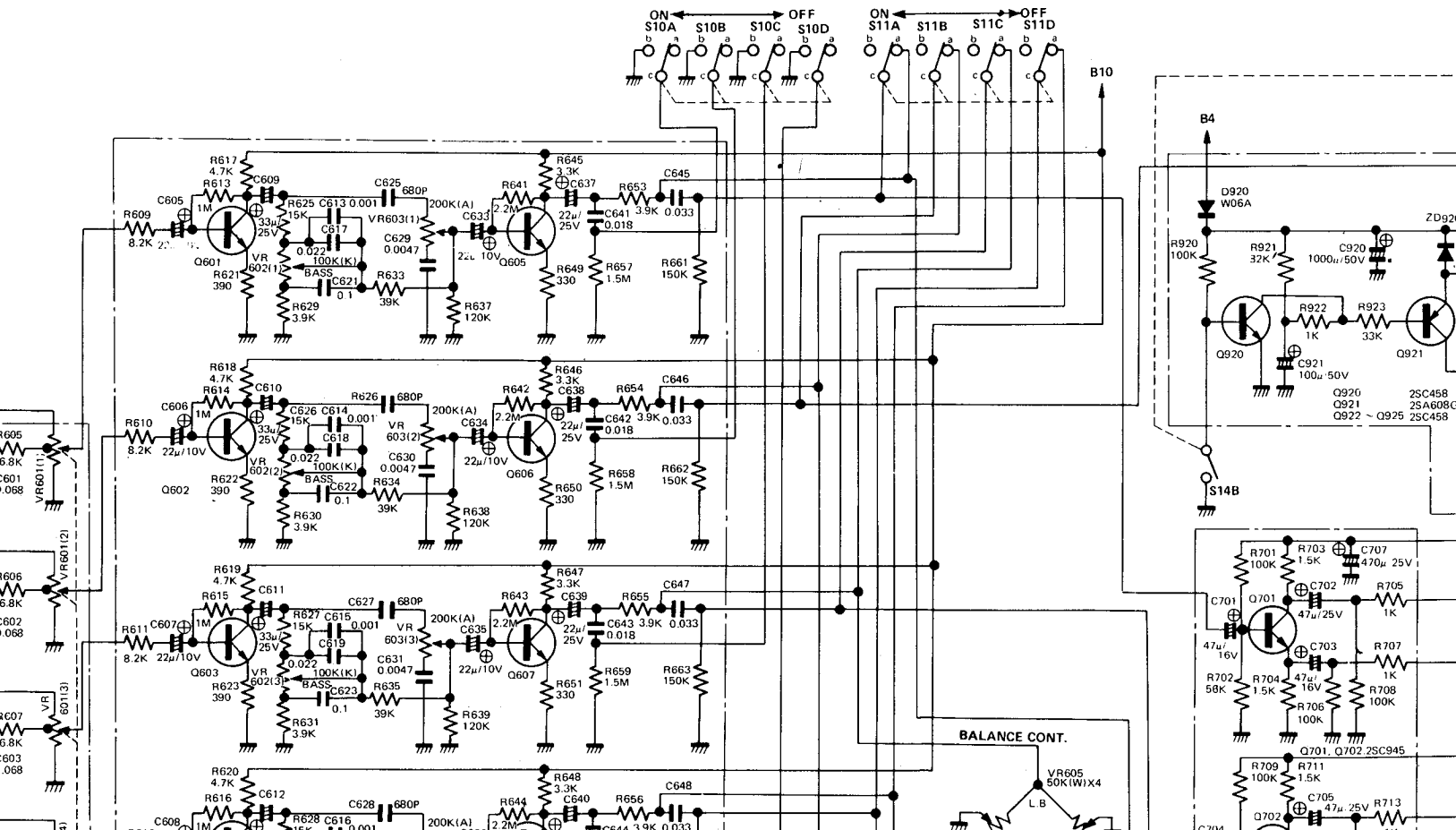
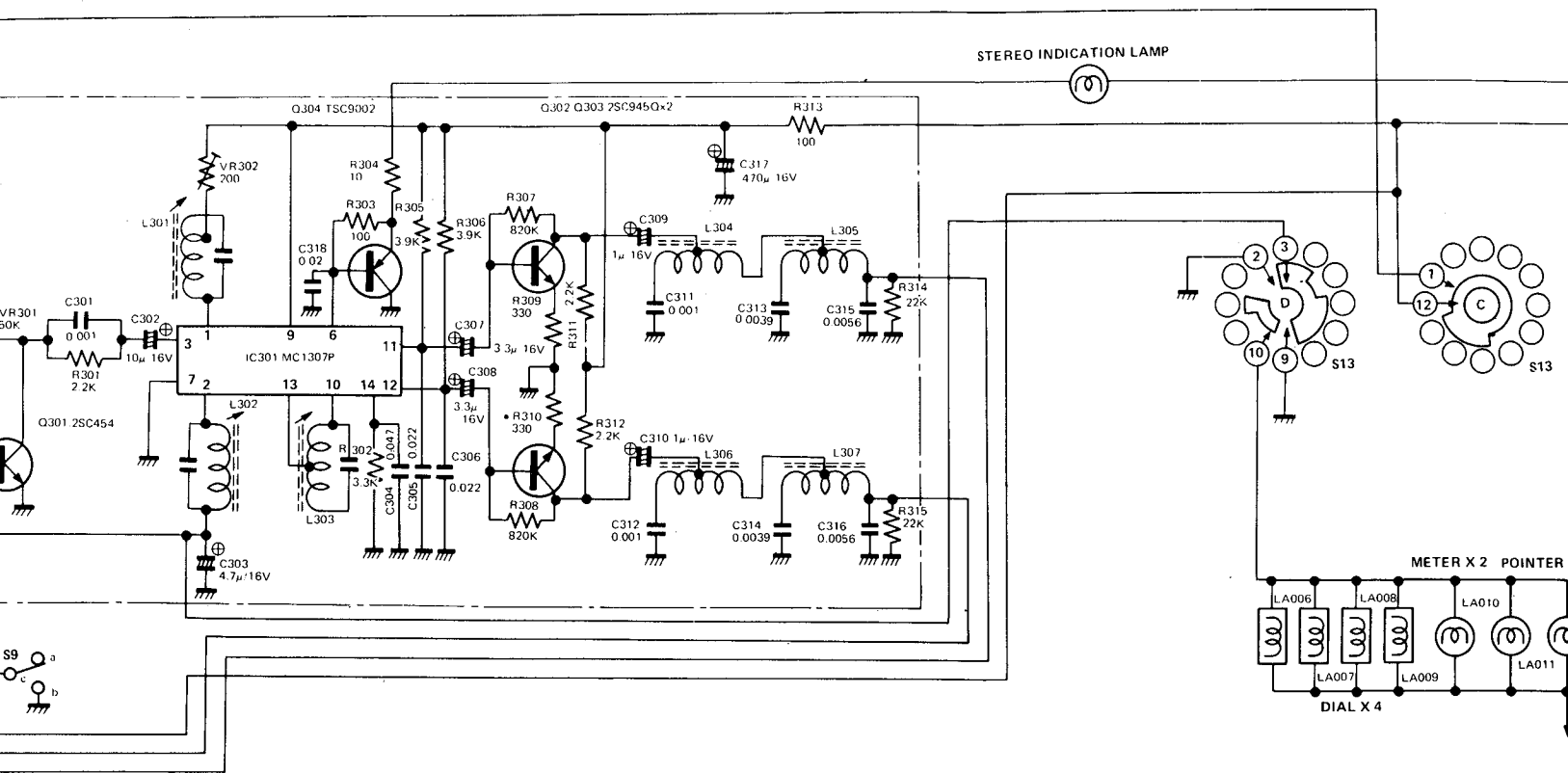

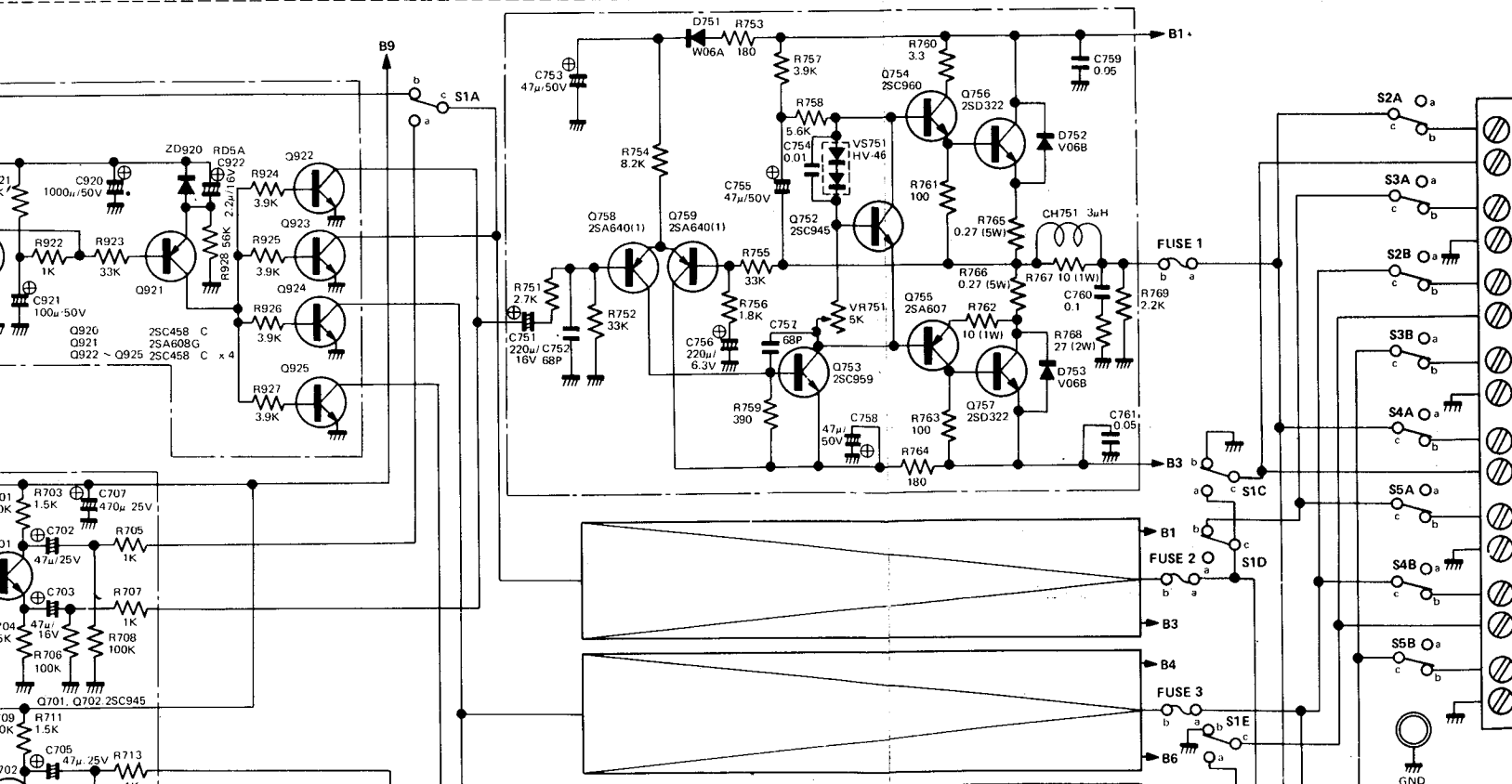
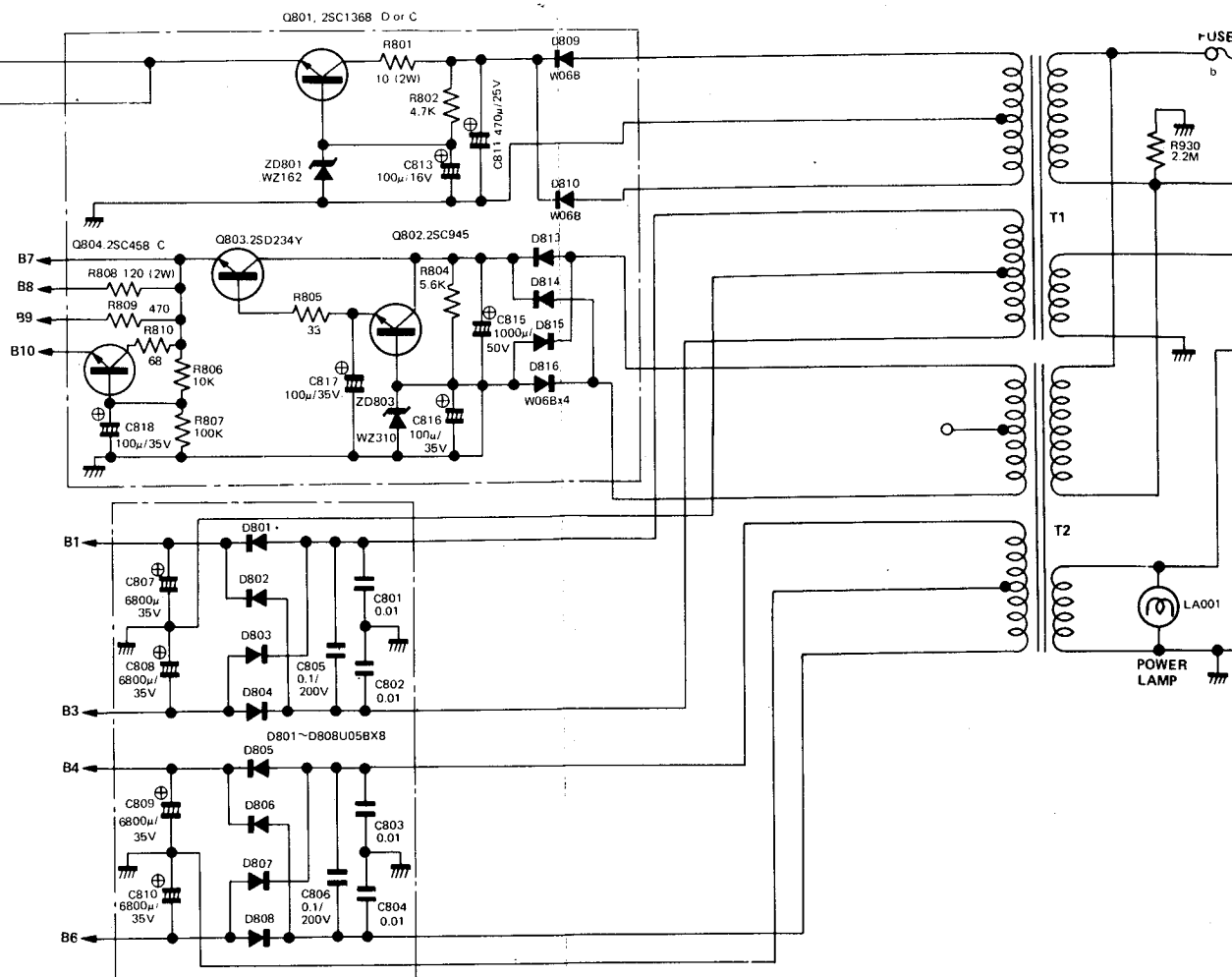
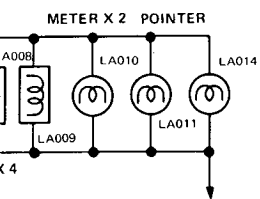
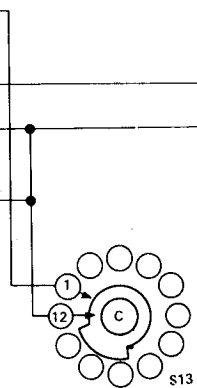

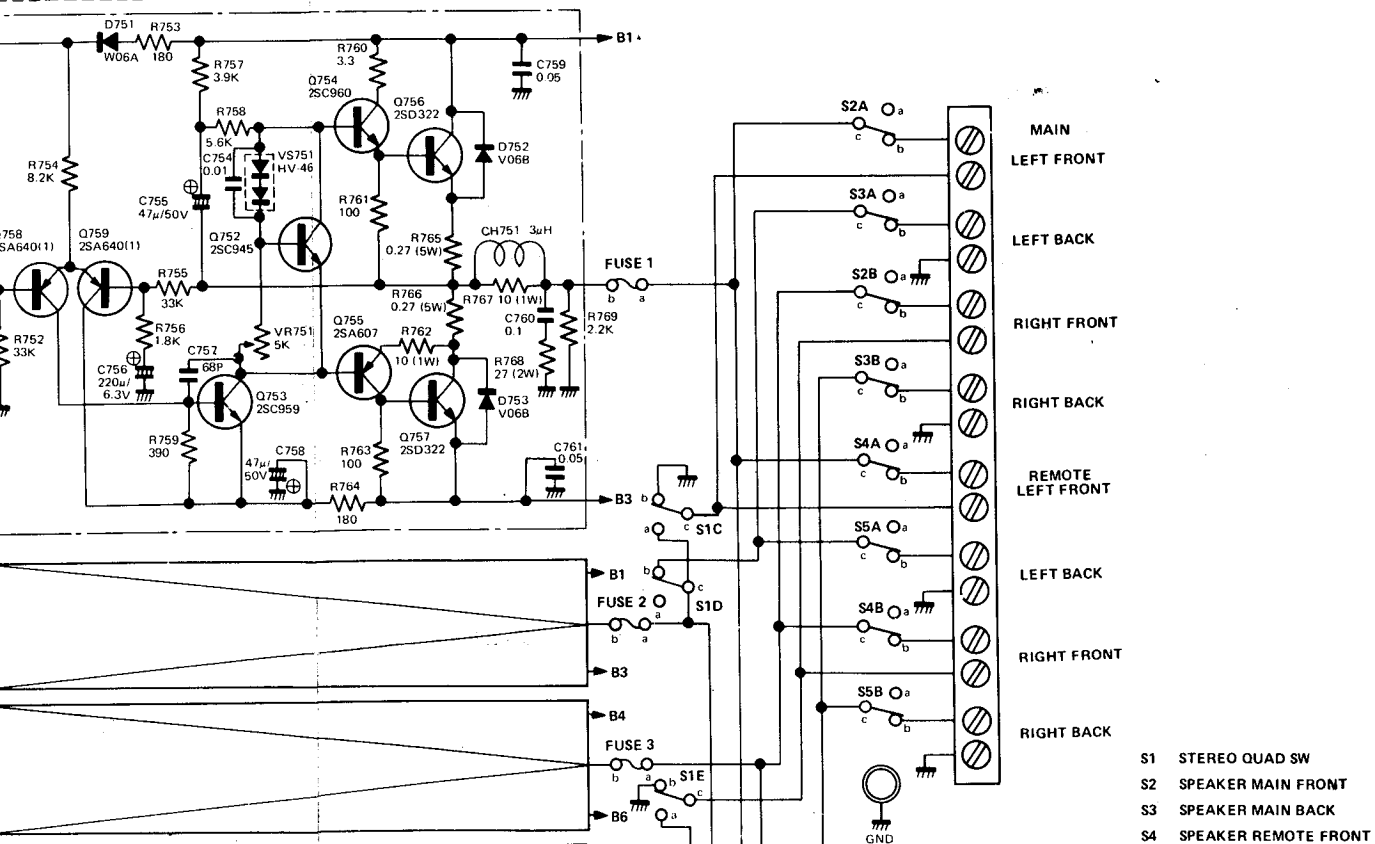
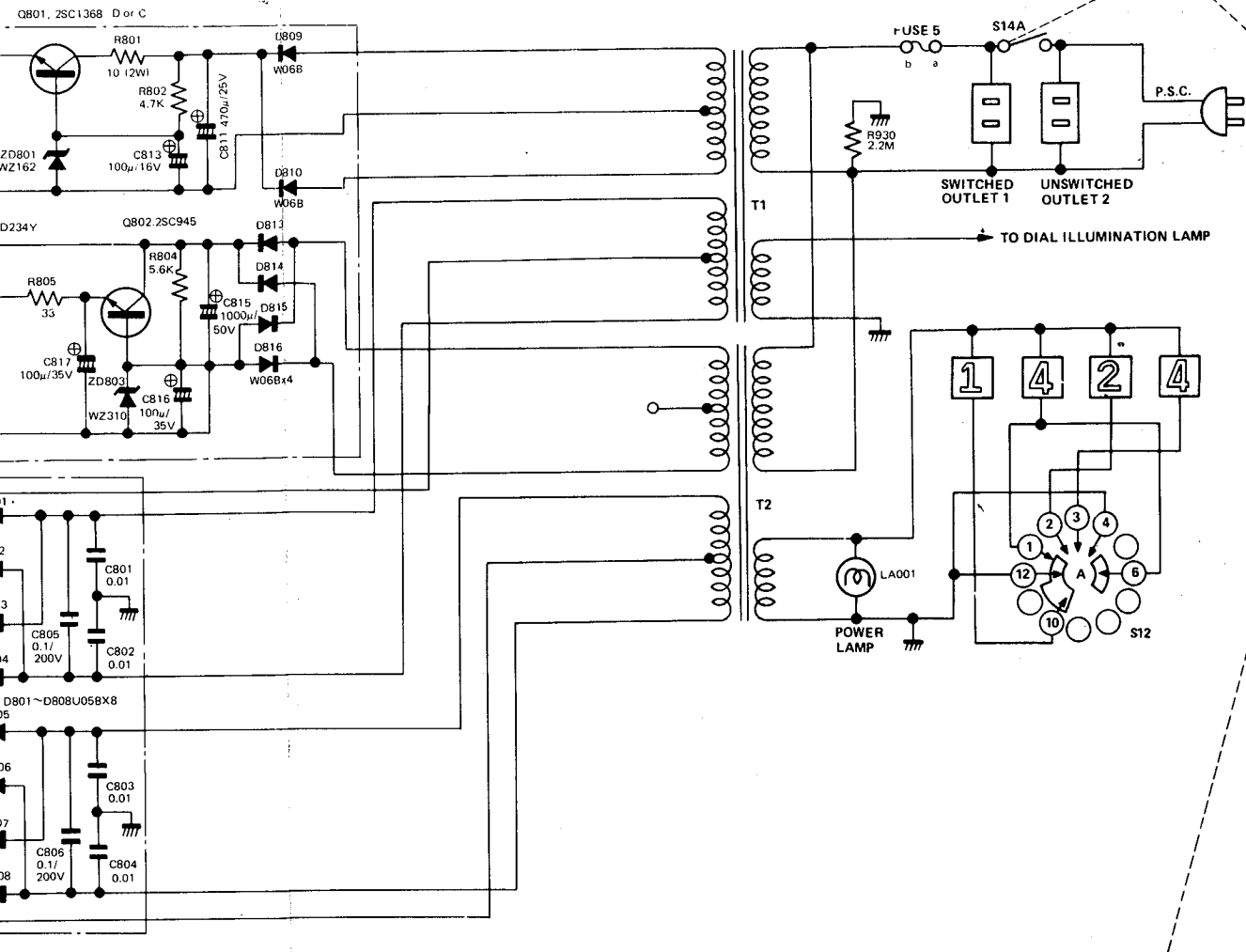

- S1 STEREO QUAD SW
- S2 SPEAKER MAIN FRONT
- S3 SPEAKER MAIN BACK
- S4 SPEAKER REMOTE FRONT

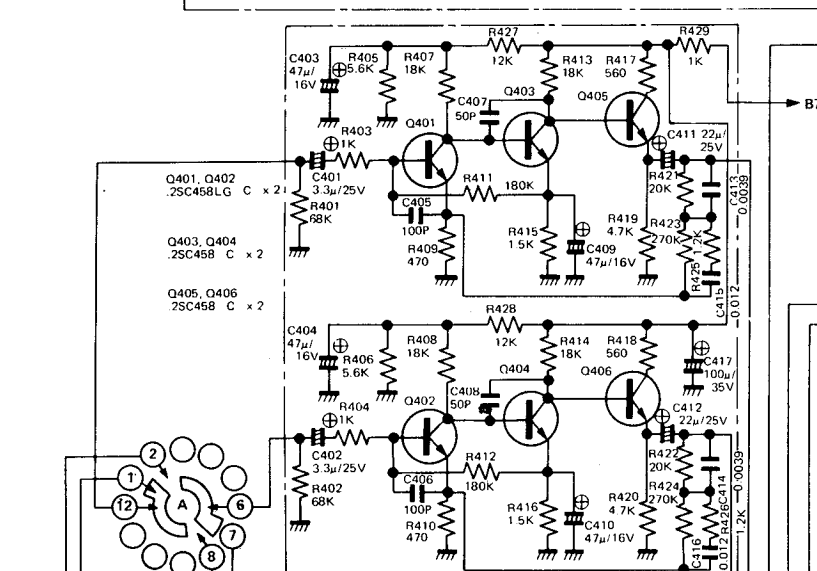
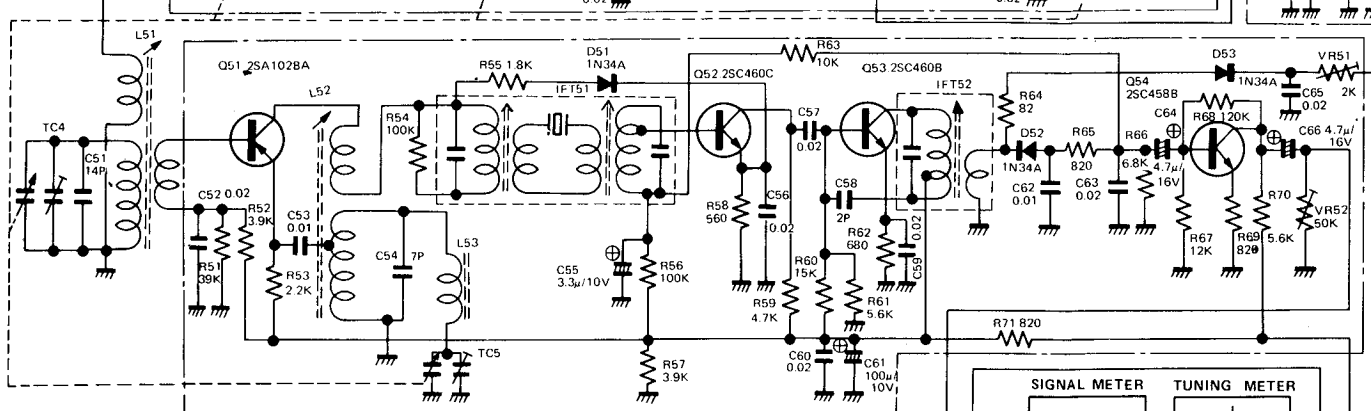

- LF
- PHONE 1
- PHONO 2
- DISCRETE PHONO/AUX
- DISCRETE PHONO/AUX
- DISCRETE FM/AUX
- TAPE OUT 1
- 2
- TAPE MONI
- DOLBY OUT
- DOLBY IN
- LB
- DISCRETE PHONO/AUX
- DISCRETE PHONO/AUX
- DISCRETE FM/AUX
- TAPE OUT 1
- 2
- TAPE MONI
- RF
- PHONE 1
- PHONO 2
- DISCRETE PHONO/AUX
- DISCRETE PHONO/AUX
- DISCRETE FM/AUX
- TAPE OUT 1
- 2
- TAPE MONI
- DOLBY OUT
- DOLBY IN
- RB
- DISCRETE PHONO/AUX
- DISCRETE PHONO/AUX
- DISCRETE FM/AUX
- TAPE OUT 1
- 2
- TAPE MONI

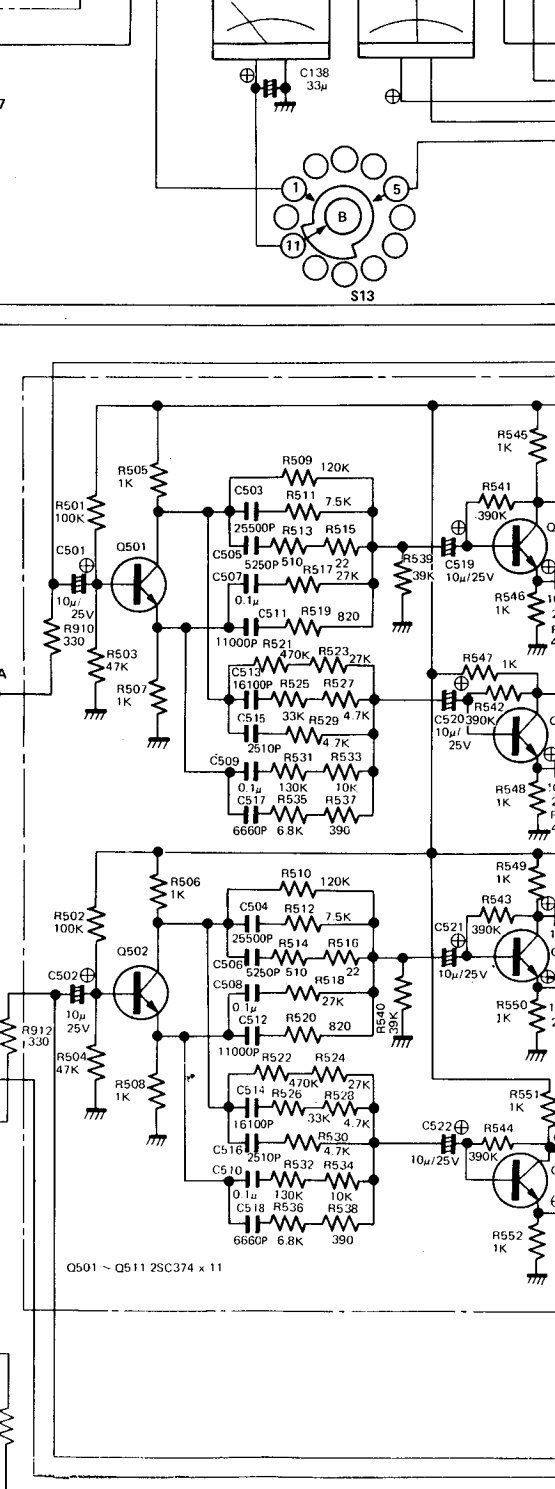
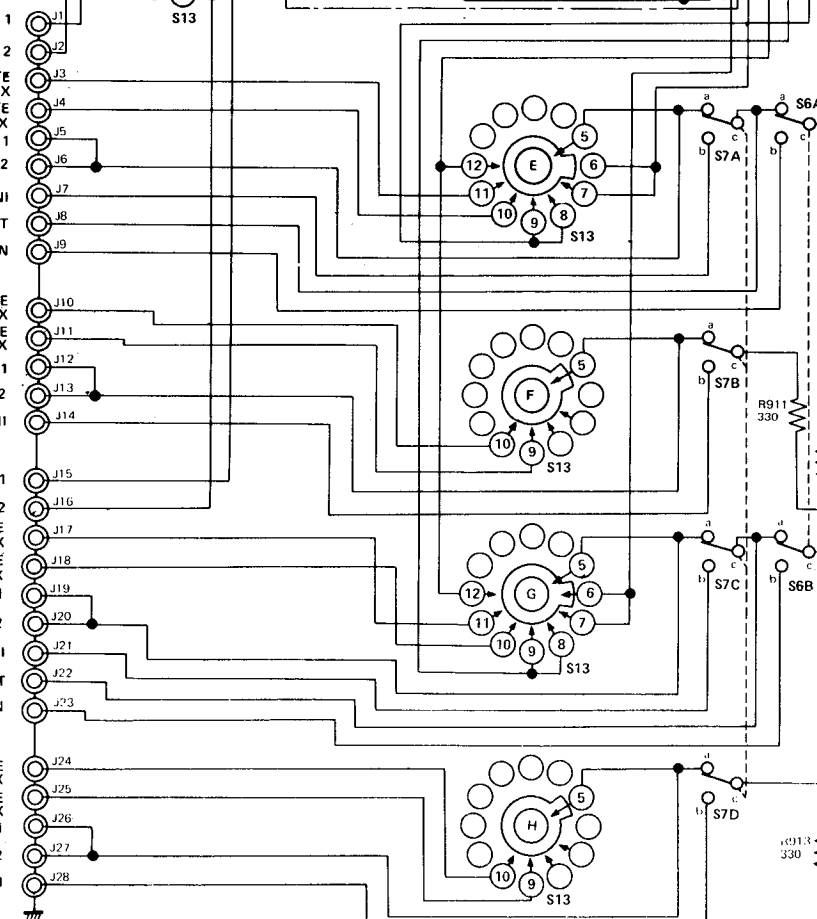

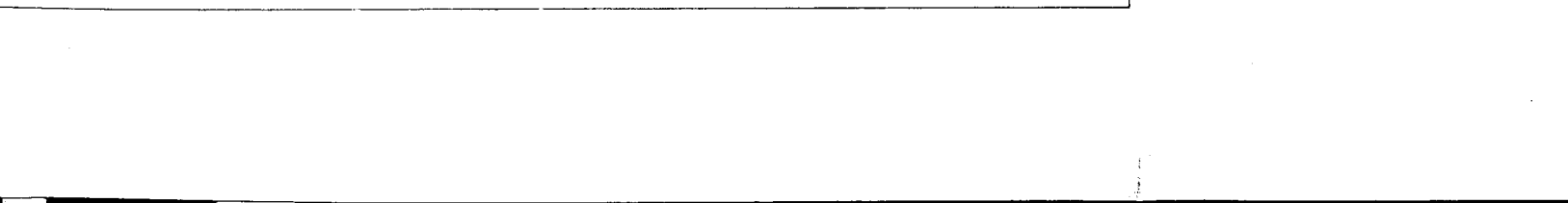
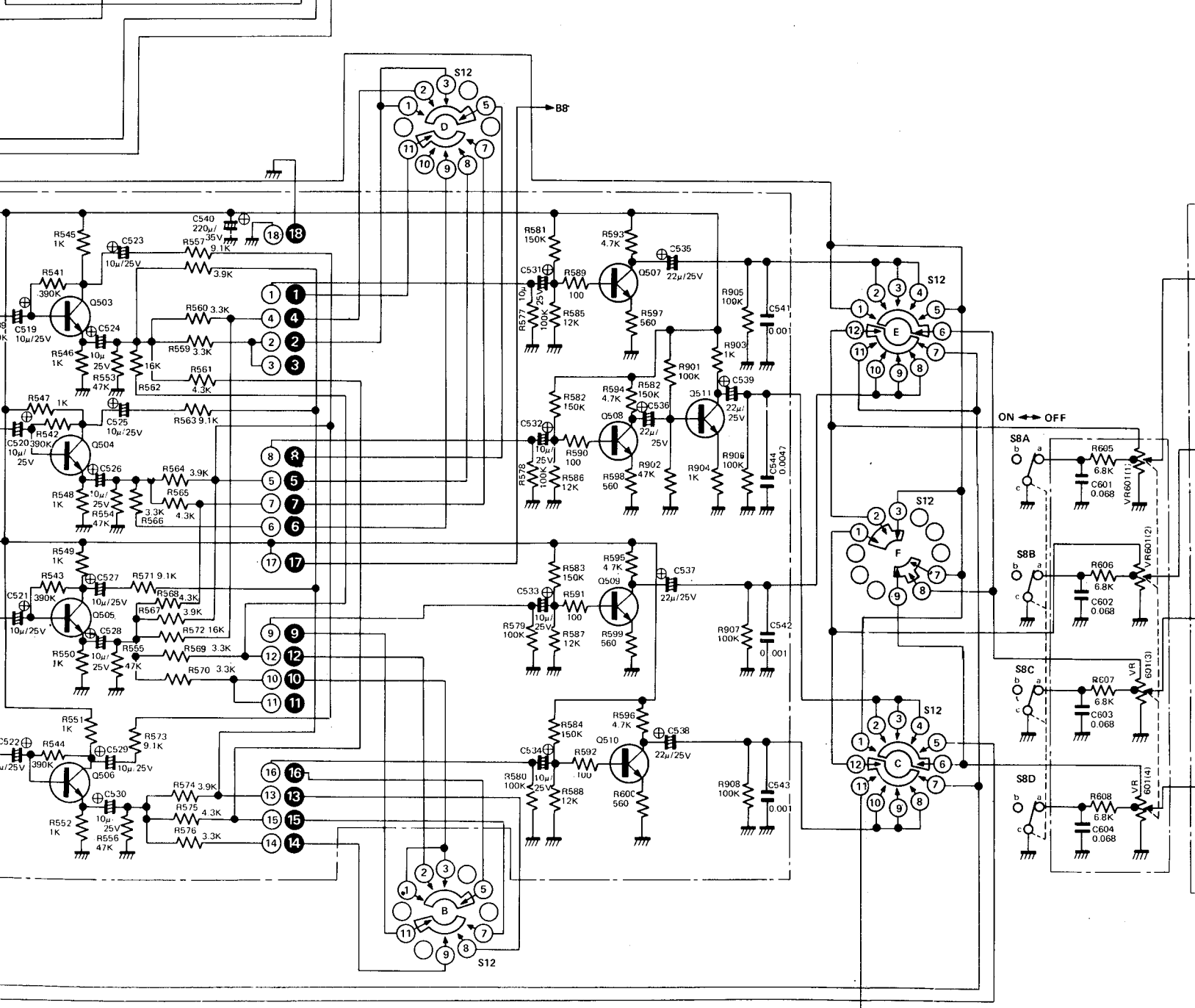
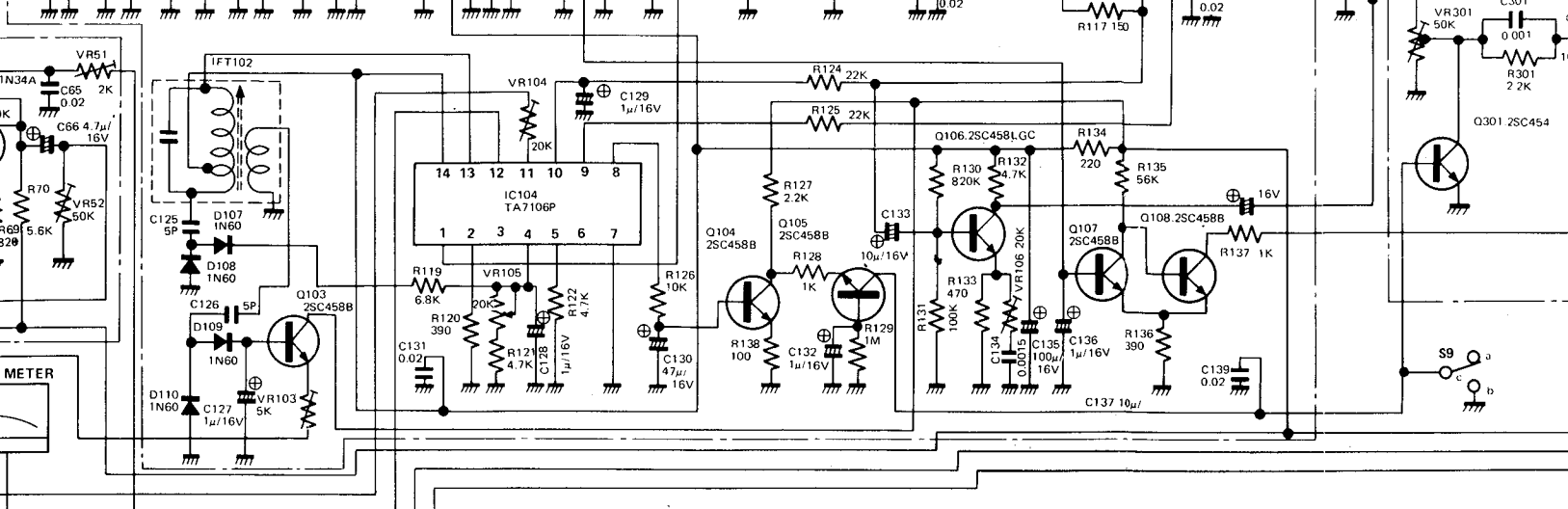

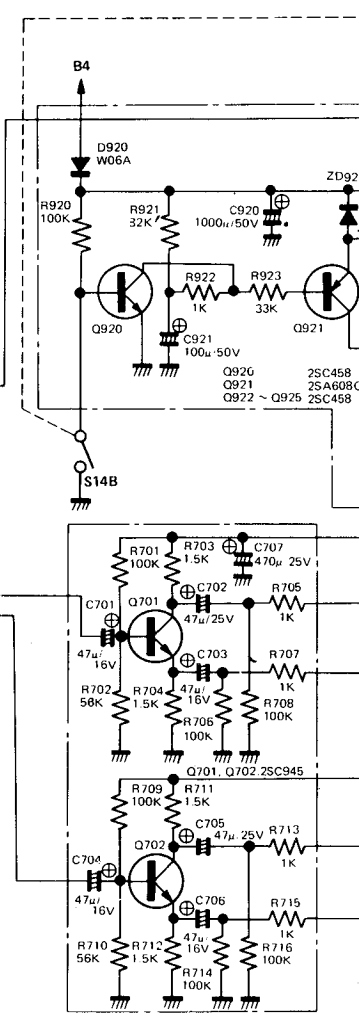
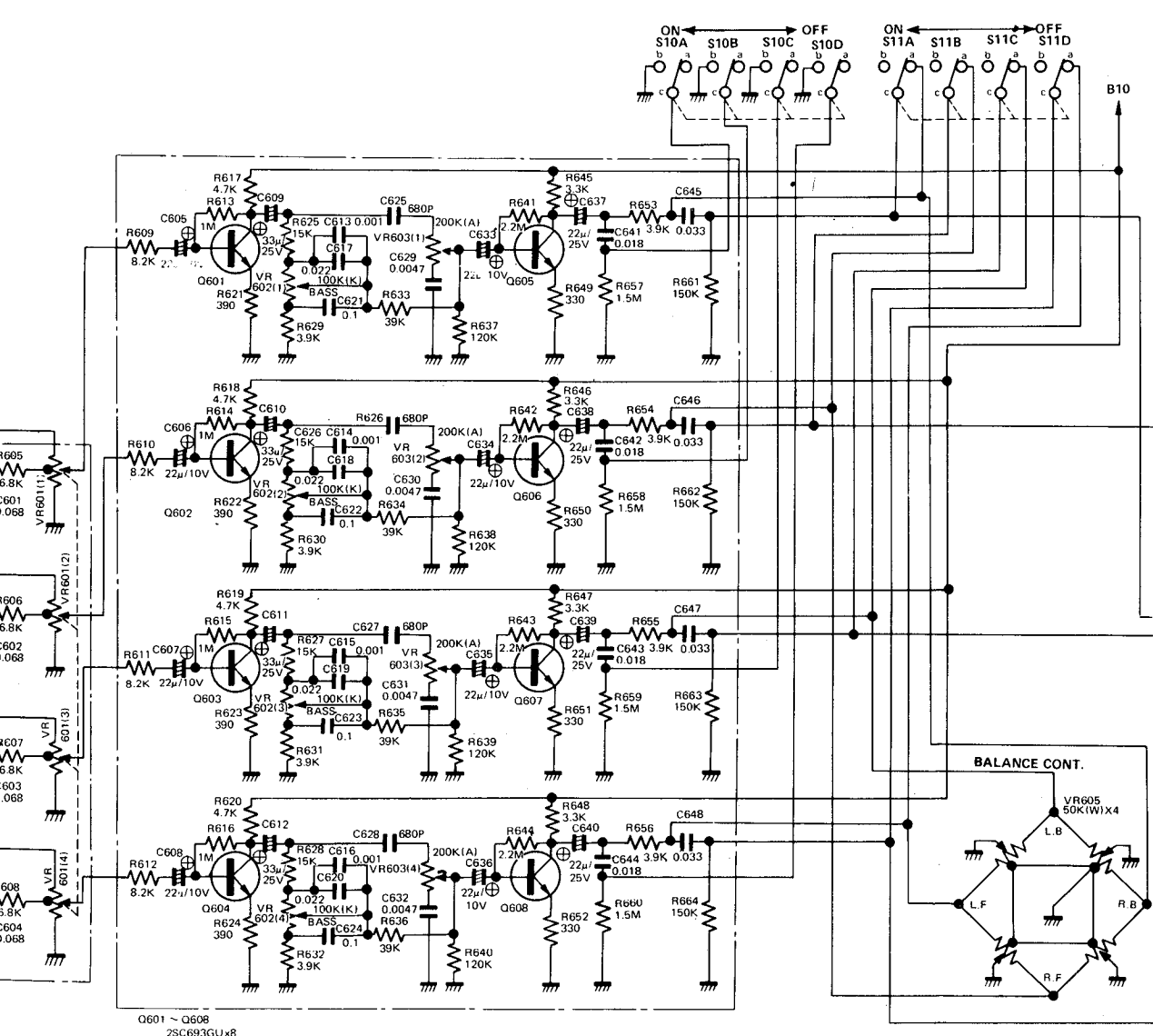
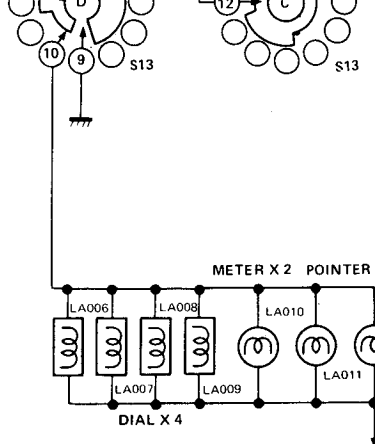
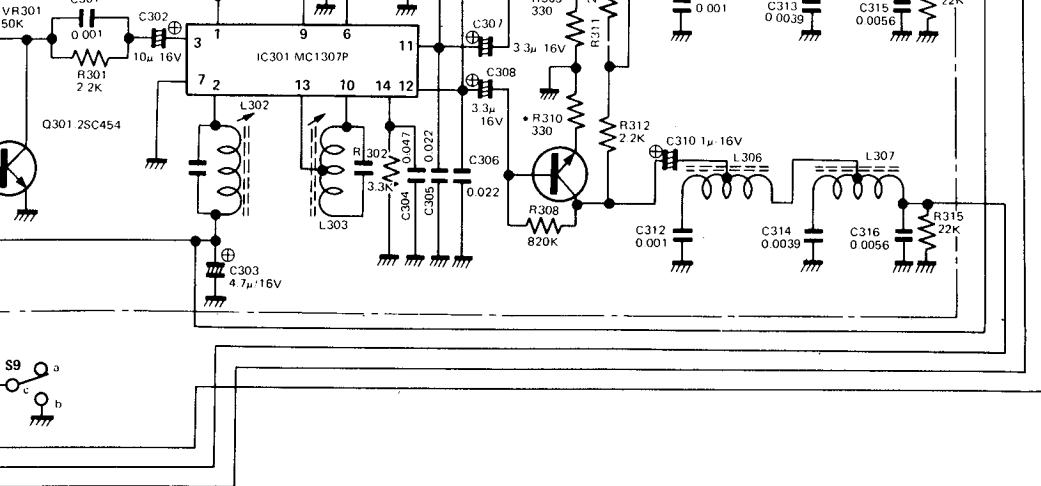

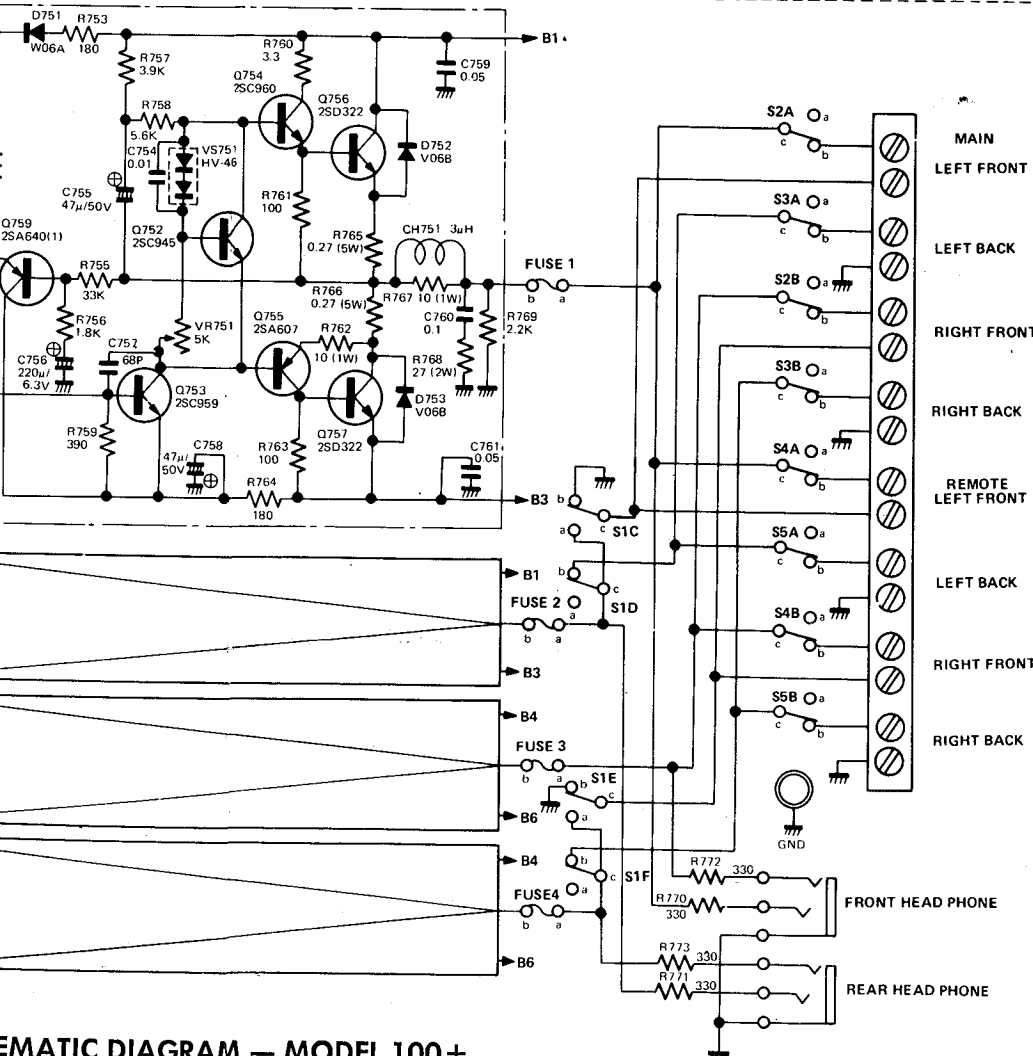
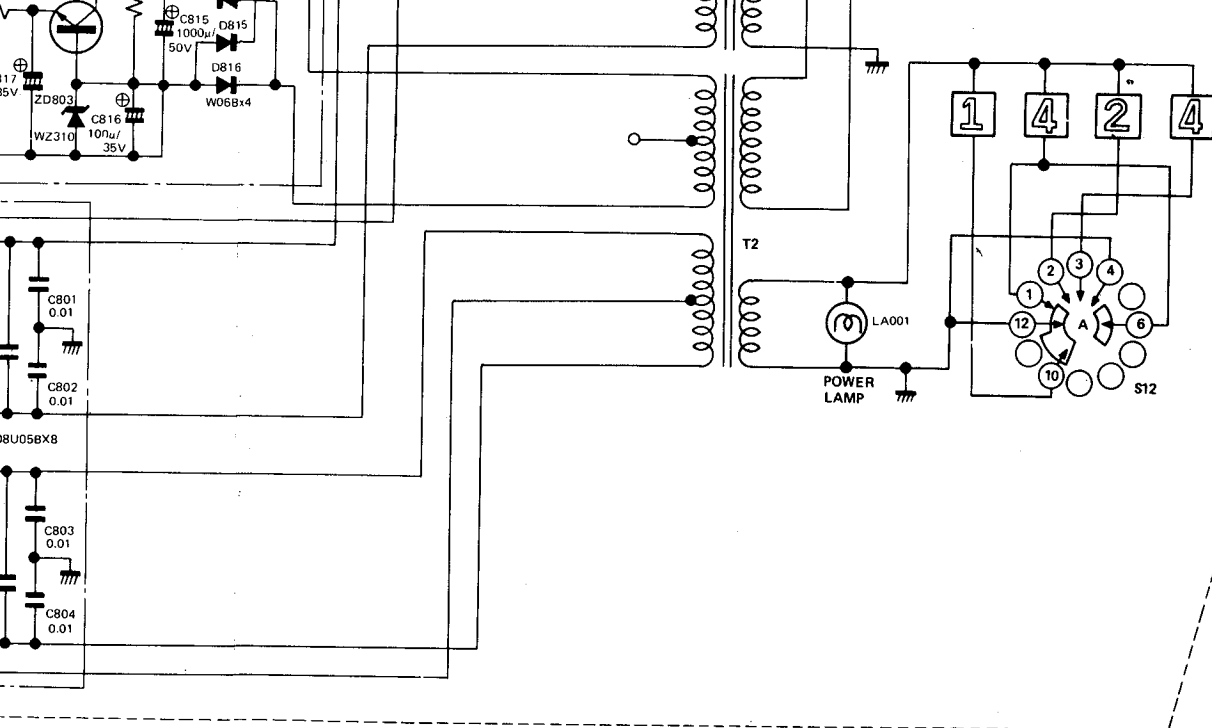

- S1 STEREO QUAD SW
- S2 SPEAKER MAIN FRONT
- S3 SPEAKER MAIN BACK
- S4 SPEAKER REMOTE FRONT
- S5 SPEAKER REMOTE BACK
- S6 DOLBY SW
- S7 TAPE MONITOR
- S8 CONTOUR
- S9 MUTING
- S10 HIGH FILTER
- S11 LOW FILTER
- S12 MODE
- S13 FUNCTION
- S14 POWER

EMATIC DIAGRAM — MODEL 100+