

ERIC NELSON
CUST. SVC.

**The Harman-Kardon
Model 150+**

**AM/Stereo FM
Multichannel Receiver**

Technical Manual

ALIGNMENT PROCEDURES

AM IF AMPLIFIER ALIGNMENT PROCEDURE

INSTRUMENT: AM Generator (With Scope)

OUTPUT OF GENERATOR: Connect to TC5 (On V.C. — AM OSC) Terminal 455KC

Adjust IFT51 for Maximum

NOTE: Keep Signal as low as possible when adjusting.

AM ALIGNMENT PROCEDURE

INSTRUMENT: AM Signal Generator, AC VTVM & Oscilloscope

NOTE: Set Function Switch to "AM"

Set Mode Switch to "MONO"

Set Volume Control to "MINIMUM"

Input Signal must be kept as low as possible to avoid A.G.C action

Steps	Signal Generator		Tuning Dial Setting	VTVM & Scope Connection	Adjustment	Adjust for
	Coupling	Frequency				
1	The Test Loop about 60 cm (2 ft.) away from AM Bar (Loop Stick) Antenna	515KHz	Frequency Minimum	L Channel Tape Out Terminal	L53 (AM OSC Coil)	Maximum Amplitude
2		1650KHz	Frequency Maximum		TC6 (AM OSC TRIMMER)	
*3						
4		600KHz (400Hz, 30% Modulation)	600KHz		L51 (BAR ANT TRIMMER) L52 (AM RF Coil)	
5		1400KHz (400Hz, 30% Modulation)	1400KHz		TC5 (BAR ANT TRIMMER) TC7 (AM RF TRIMMER)	
*6						
7		1000KHz (400Hz, 30% Modulation)	1000KHz		VR52	0.225V (RMS) Output
8		Generator Output 0.1V			VR53	Tuning Meter Full Scale
*3	Repeat Steps 1 and 2 until no further improvement is notice					
*6	Repeat Steps 4 and 5 until no further improvement is notice					

FM FRONT END ALIGNMENT PROCEDURE

INSTRUMENT: FM Signal Generator, AC VTVM & Oscilloscope

NOTE: Set Function Switch to "FM"

Set Mode Switch to "MONO"

Set Volume Control to "MINIMUM"

Input Signal must be kept as low as possible to avoid limiting point

Steps	Generator Connection	Generator Frequency	Tuning Dial Setting	VIVM & Oscilloscope Connection	Adjustment & Function	Adjust for
1	Connect FM Signal Generator to FM Ant Terminal	87MHz (400Hz, 75KHz DEVIATION)	Frequency Minimum	L, or R Channel Tape Out Terminal	L4 (FM OSC Coil)	Maximum Amplitude & Undistortion Sine Wave on Scope
2		109MHz (400Hz, 75KHz DEVIATION)	Frequency Maximum		TC4 (FM OSC TRIMMER)	
*3						
4		90MHz (400Hz, 75KHz Deviation)	90MHz		L1 (FM Ant Coil) L2 (FM RF1 Coil) L3 (FM RF2 Coil)	
5		106MHz (400Hz, 75KHz Deviation)	106MHz		TC1 (FM Ant Trimmer) TC2 (FM RF1 Trimmer) TC3 (FM RF2 Trimmer)	
6	Repeat steps 4 and 5 until no further improvement is noticed					
*3	Repeat steps 1 and 2 until no further improvement is noticed					

FM IF AMPLIFIER ALIGNMENT PROCEDURE

INSTRUMENT: FM Signal Generator, FM Stereo Generator, AC VTVM, DC VTVM, Oscilloscope & Distortion Meter

NOTE: Set Function Switch to "FM"

Set Mode Switch to "MONO"

Set Volume Control to "MINIMUM"

The Front End Alignment must be completed.

GENERATOR CONNECTION: Connect FM Signal Generator to FM Ant Terminal

GENERATOR FREQUENCY: 98MHz (400Hz, 75KHz Deviation)

TUNING DIAL: 98MHz

AC VTVM, OSCILLOSCOPE & DISTORTION METER CONNECTION: L, or R Channel Tape Out Terminal

NOTE: All Readings indicated are at Generator

Step	Input Signal Level	DC VTVM Connection	Adjustment & Function	Adjust for
1	Must be kept as low as possible to avoid limiting point		Front End IFT & IF Amp IFT101 (Bottom Core) Disc. CAN.	Maximum Amplitude and Undistortion Sine Wave On Oscilloscope
2	At No Input Signal	Bottom IF Amp P.C.B (R121, R123)	IF Amp IFT101 (Top Core) Disc. CAN.	OV DC
3	At No Input Signal	#8 Pin IF Board	VR101	OV DC
4	100 μ V		IF Amp IFT101 (Bottom Core) Disc. CAN.	Distortion Minimum Harmonic Analyzer

STEPS 5: OSCILLOSCOPE CONNECTION: FM QUAD Terminal

Input Level 1000 μ V

Adjust VR102 for flat base line composite MPX Signal

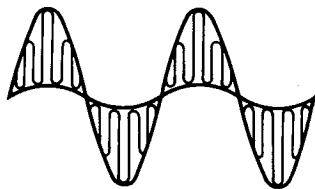

VR102 UNDER COMPENSATED

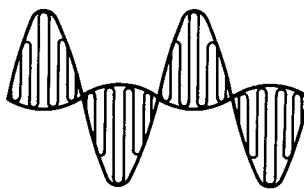

VR102 OVER COMPENSATED

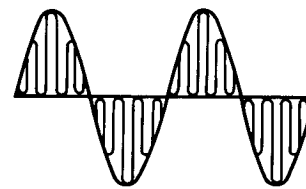

VR102 CORRECT

FM METER ALIGNMENT PROCEDURE

INSTRUMENT: FM Signal Generator, FM Stereo Generator, AC VTVM, DC VTVM & Oscilloscope

NOTE: Set Function Switch to "FM STEREO"

Set Mode Switch to "STEREO"

Set Volume Control to "MINIMUM"

The FM Front End the FM IF Amplifier must be completed.

GENERATOR CONNECTION: Connect FM Signal Generator to FM Ant Terminal

GENERATOR FREQUENCY: 98MHz (400Hz, 75KHz Deviation)

TUNING DIAL SETTING: 98MHz

AC VTVM' OSCILLOSCOPE & DISTORTION METER CONNECTION: L, or R Channel Tape Out Terminal

FM Muting in OFF Position and Muting Threshold in CCW Position

Step	Input Signal Level	DC VTVM Connection	Adjustment & Function	Adjust for
1	At No Input Signal	#16 Pin Meter Board	VR206	DC Minimum
2	40 μ V	#16 Pin Meter Board	VR205 VR201	DC Minimum In Tune Light Turn On
3	At No Input Signal		VR202	Meter Pointer To Maximum O Quieting
4	30 μ V (Stereo Signal)		VR203	Stereo Light Turn On

FM MPX STEREO ALIGNMENT PROCEDURE

INSTRUMENT: FM Signal Generator, FM Stereo Generator, AC VTVM, & Oscilloscope (High Impedance and Low Capacity Probe)

NOTE: Set Function Switch to "FM STEREO"
Set Mode Switch to "STEREO"

The FM Front End and FM IF Amp Alignment must be completed before attempting this FM MPX Stereo Alignment. Poor Front End and IF Alignment will result in Poor FM MPX Stereo Adjustment.

Steps	FM Stereo Generator		Output Indicator Connected to	Adjustment & Function	Adjust for
	Signal	Modulation			
1	Main Signal	100%	VTVM & Oscilloscope To Left Channel Tape Out Terminal	VR301	0.75V (RMS) Output
2	19KHz Pilot Signal Only	Less 5%	Probe Of Oscilloscope To Test Point	L301, L302 L303	Maximum Reading On Oscilloscope
3	Composite Signal To Left Channel Only	1000 μ V Signal Pilot 10%	VTVM & Oscilloscope To Left Channel Tape Out Terminal	L301	Maximum Amplitude And Undistortion Sine Wave On Oscilloscope
4	Composite Signal To Right Chan Only				Minimum Reading Minimum Reading
5	19KHz Pilot Signal Only	5.5%		VR302	Stereo Light Turn On
6		Repeat Steps 3 – 4			

AUDIO DRIVER BIAS ADJUSTMENT

1. Set volume control to minimum position.
2. Connect 8 ohm load resistor to speaker terminals in parallel.
3. Connect 20 mV DC millivolt meter to LEFT FRONT (L_f) channel test point TP1 and TP2 (R765).
4. Adjust bias control VR751 until millivolt meter indicates 8 mV.
5. Repeat preceding steps for L_b, R_f, and R_b channel.

CHANGING THE STEREO 4CH SWITCH

This receiver operates at 30W per channel, four channels driven, in the "4CH" switch position and 70W per channel, two channels driven, in the "Stereo" switch position.

The switch is factory set in the 4CH position. To switch to the STEREO mode remove the black screw holding the black lock plate (left side of switch). Reset this screw and switch to the STEREO position. Replace the lock plate by removing the black screw to the right of the 4CH designation. Reverse the plate and reset so that the switch is now locked in the STEREO position. Replace screw.

When the receiver operates in the STEREO mode the signal will only appear on the LEFT FRONT and RIGHT FRONT speaker terminals. There is no signal on the LEFT & RIGHT BACK terminals.

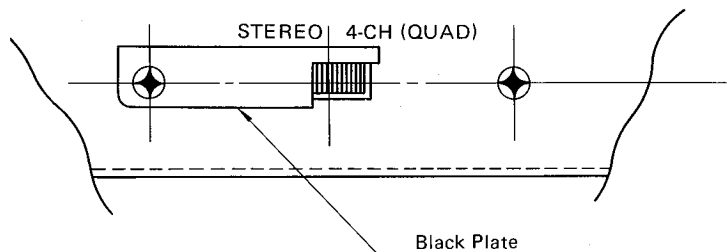

PHONO EQUALIZER BOARD

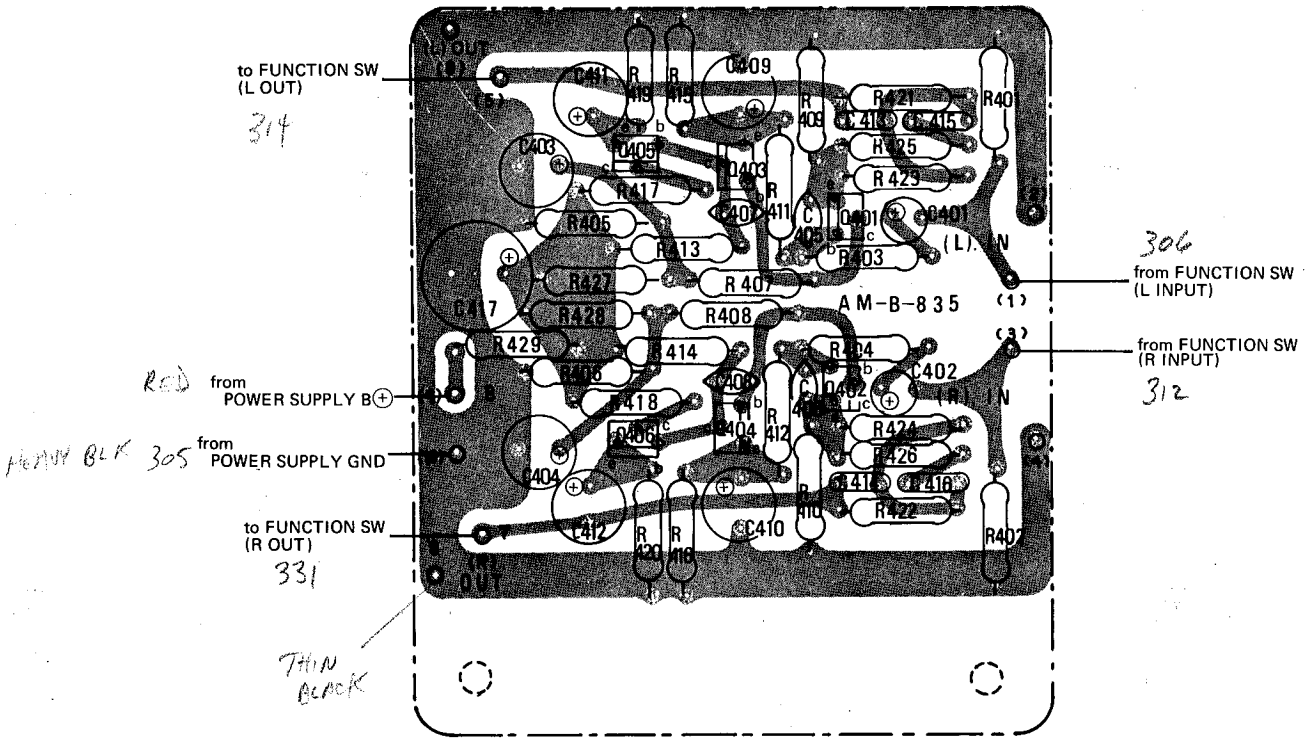

POWER AMP BOARD

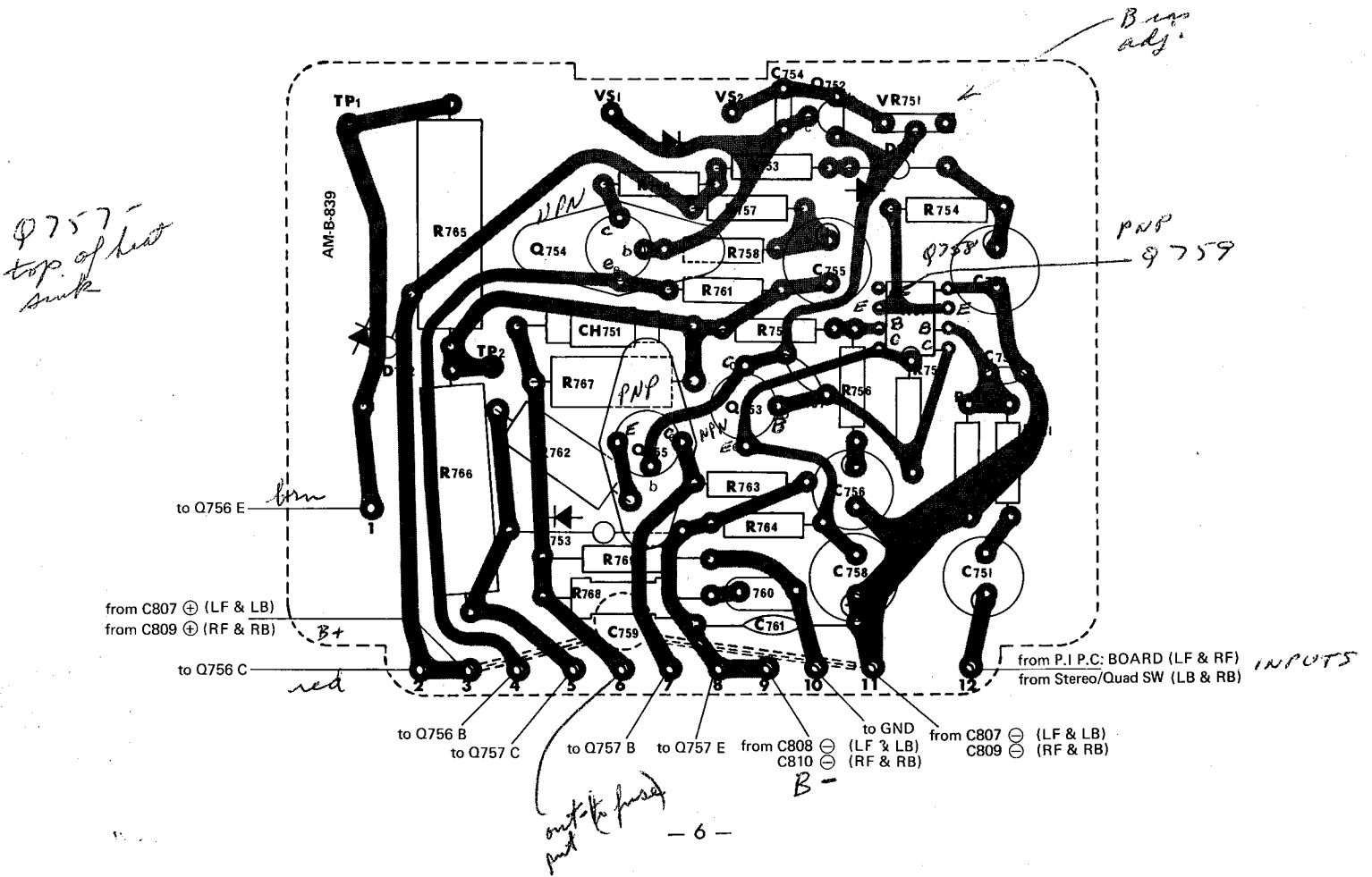

AM TUNER BOARD

AM TUNER P.C. BOARD

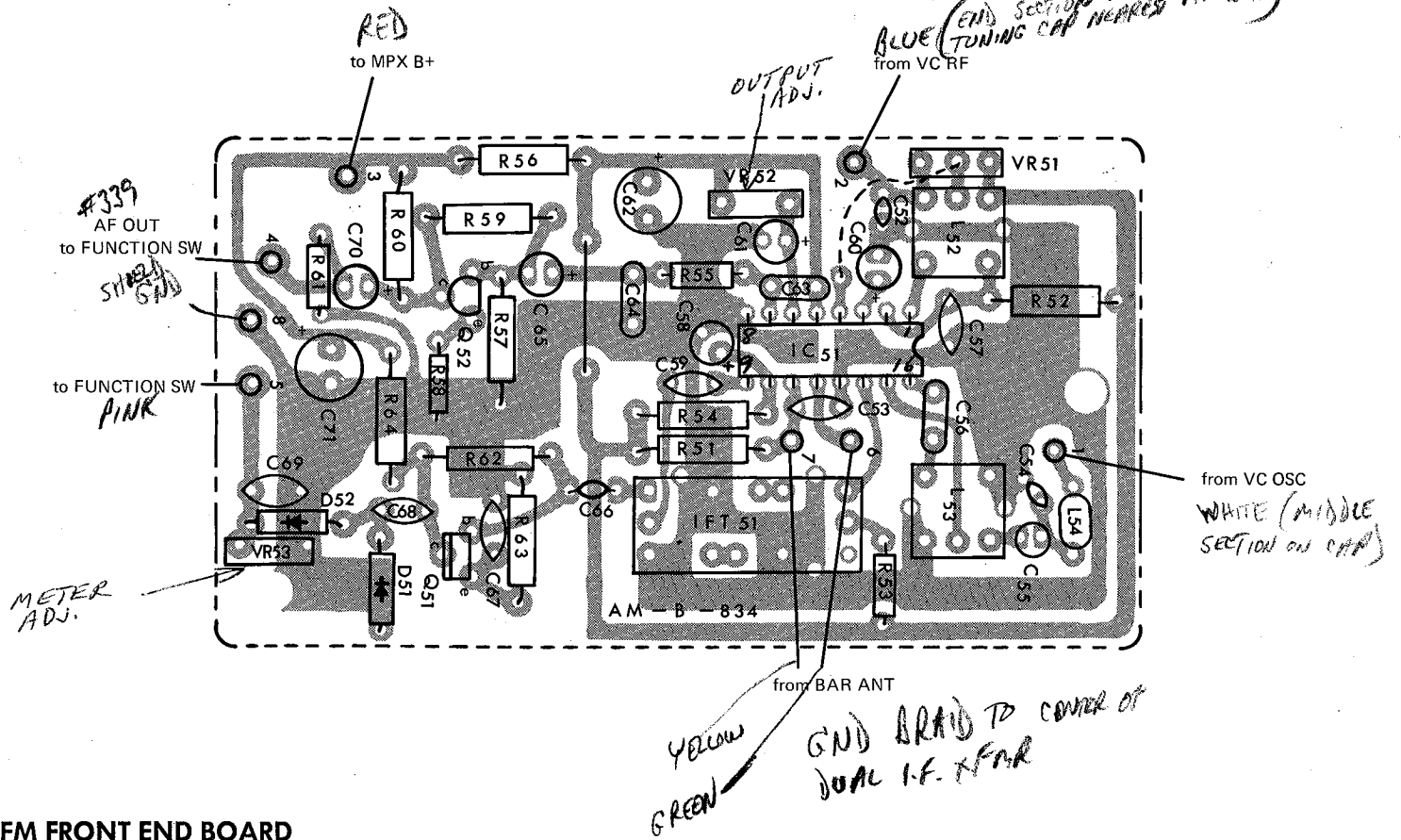

FM FRONT END BOARD

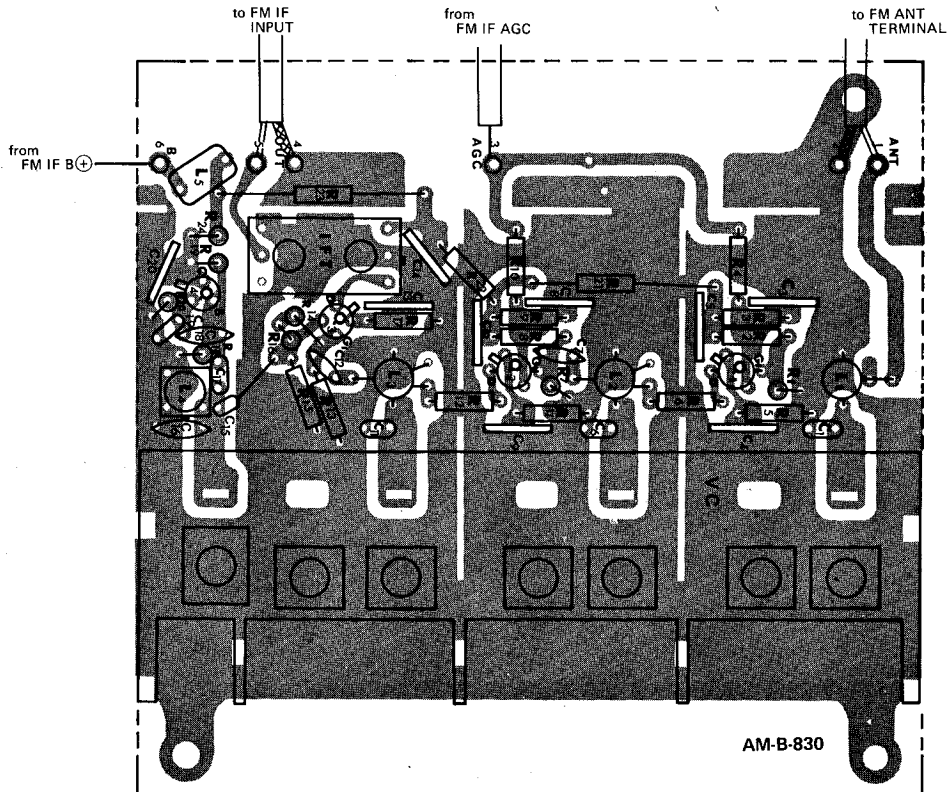

TONE CONTROL BOARD

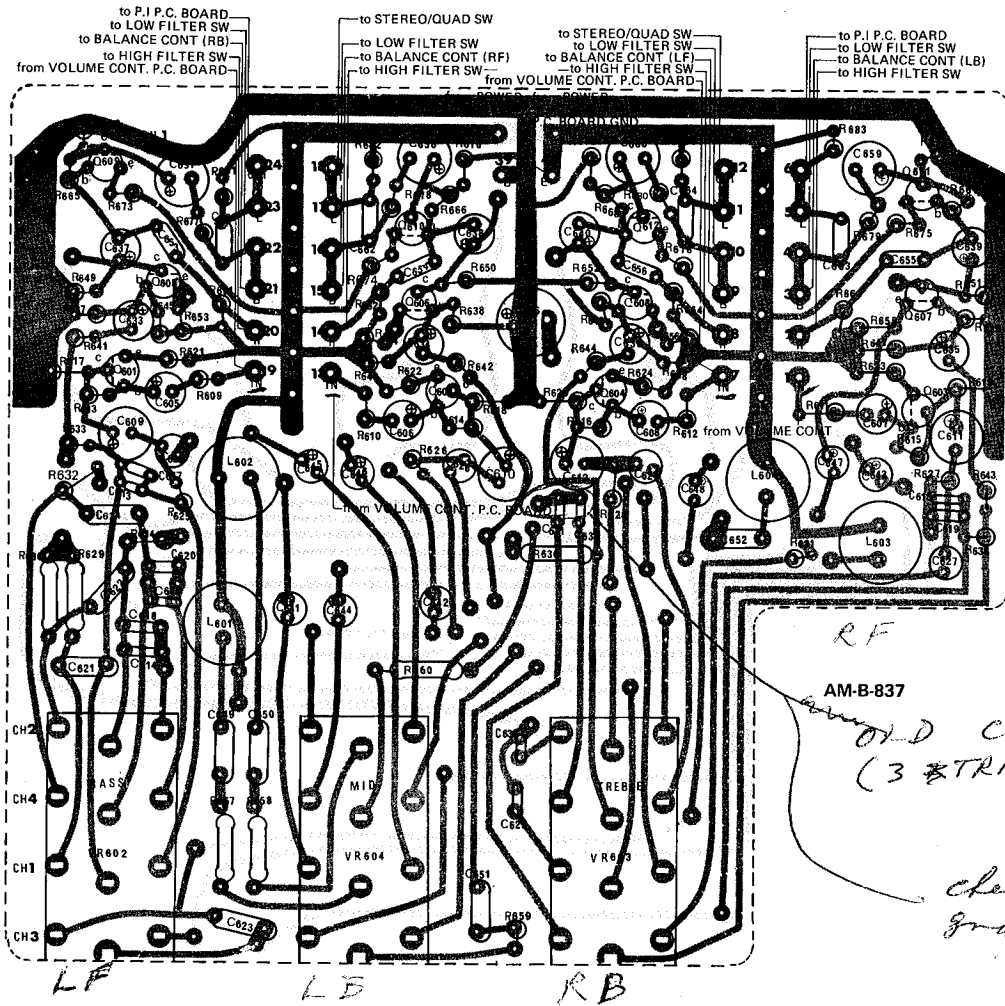

FM IF BOARD

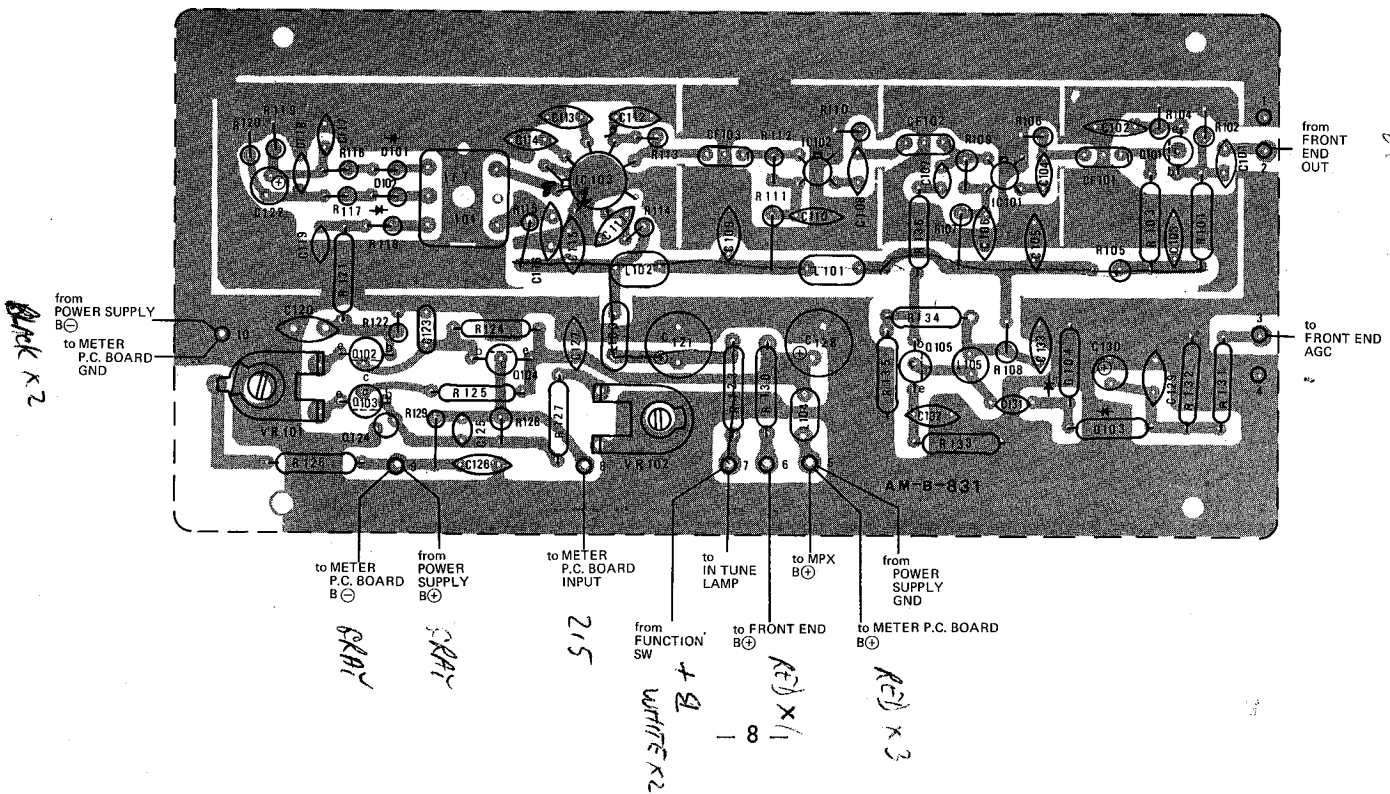

VOLUME CONTROL BOARD

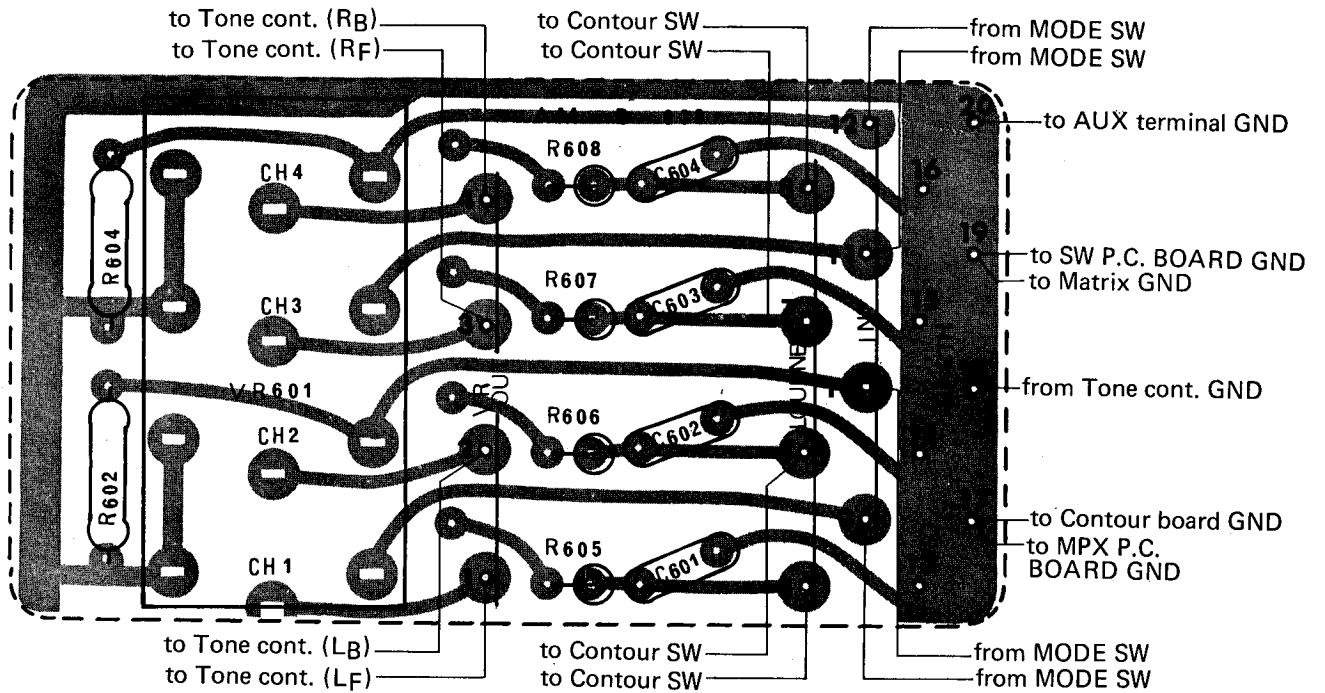

MPX BOARD

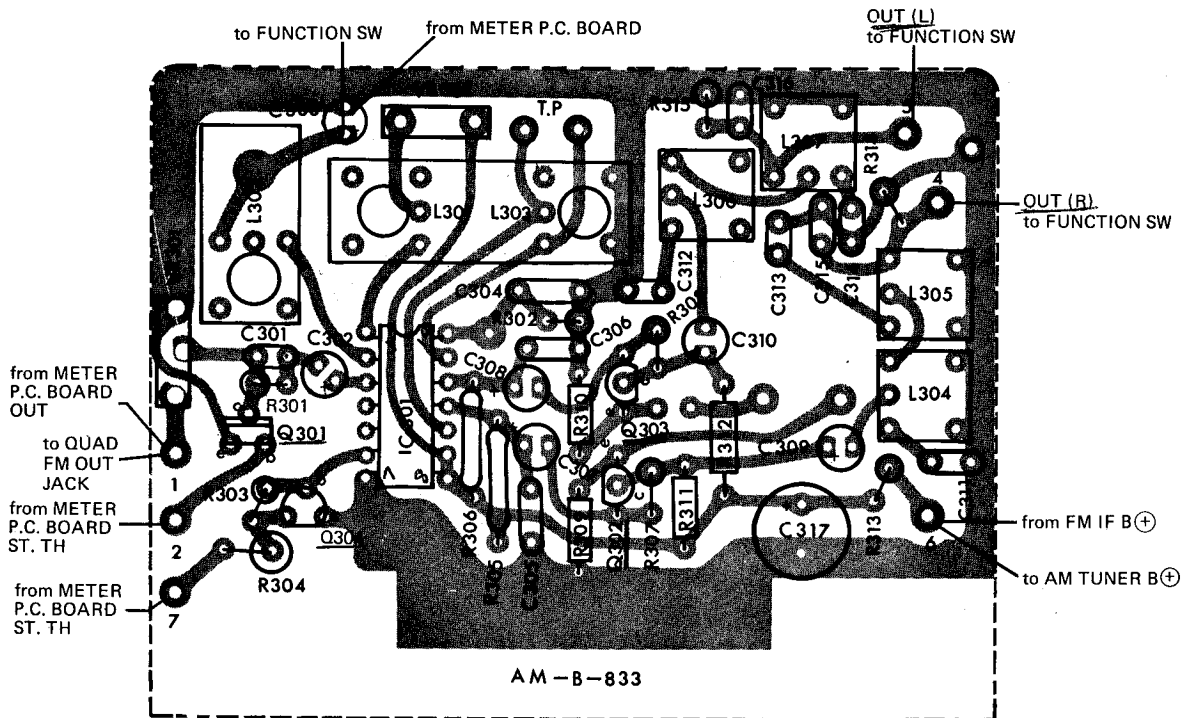

RECTIFIER BOARD

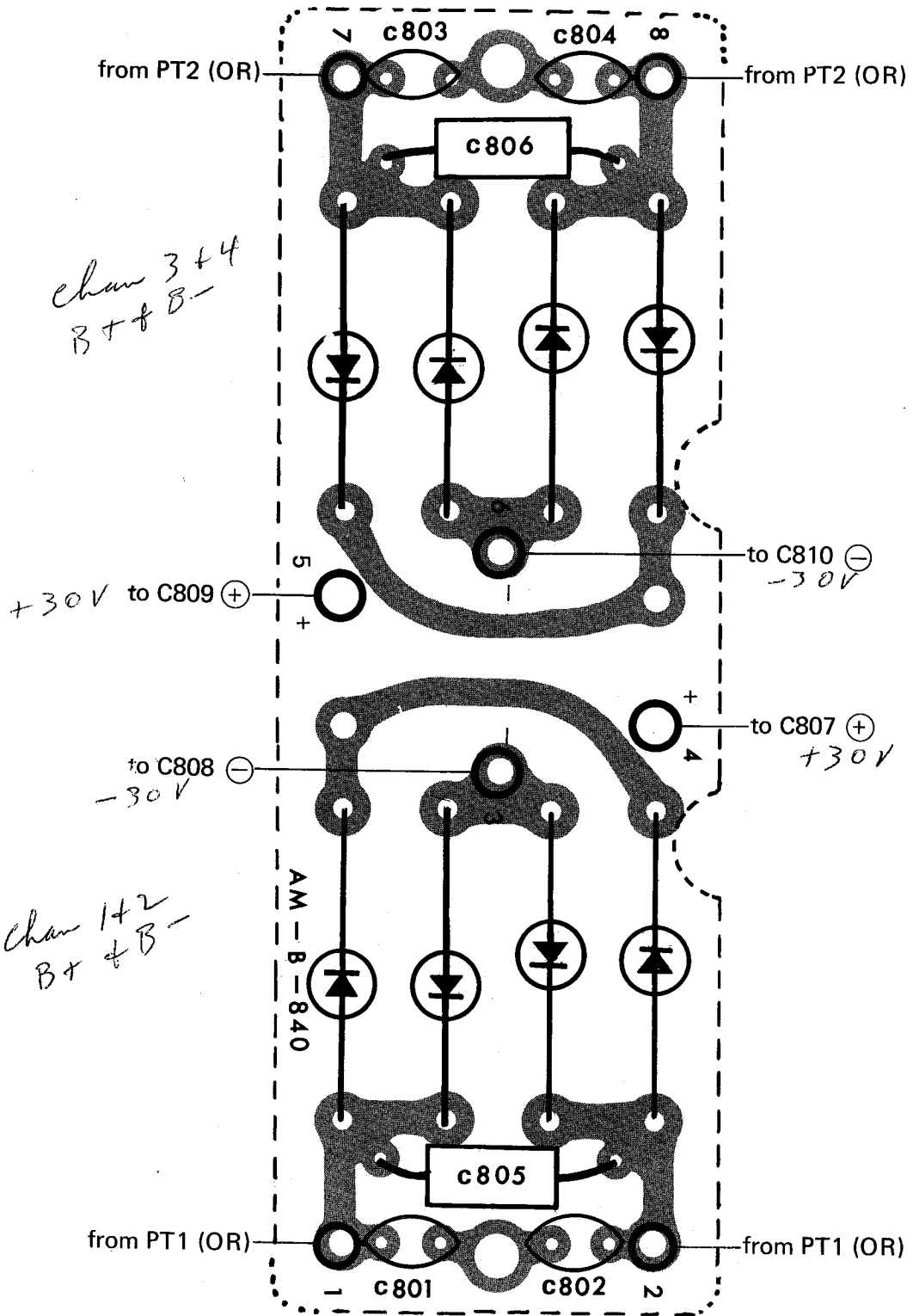

PHASE INVERTER BOARD

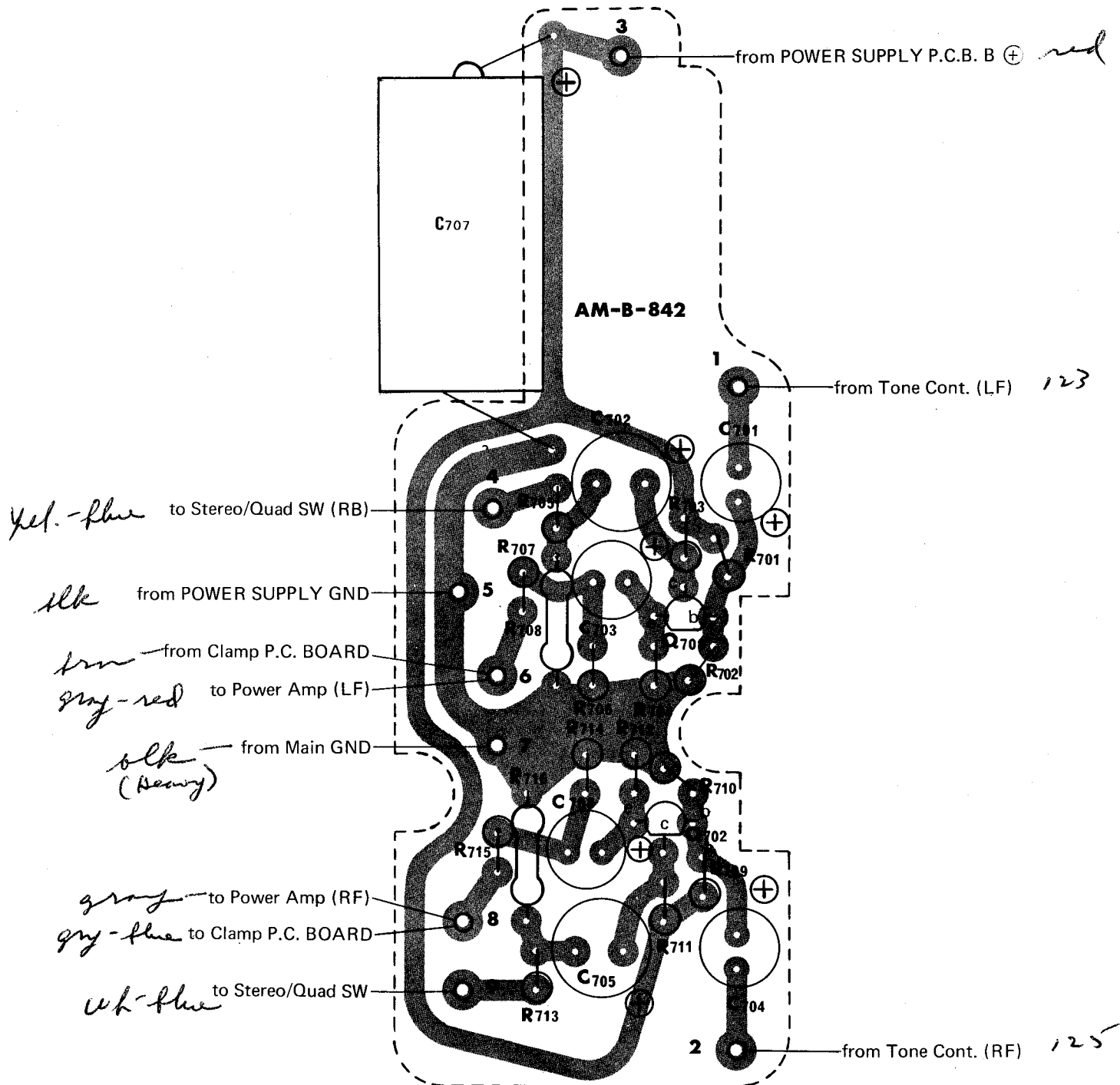

POWER SUPPLY BOARD

*use ~~700~~
C495*

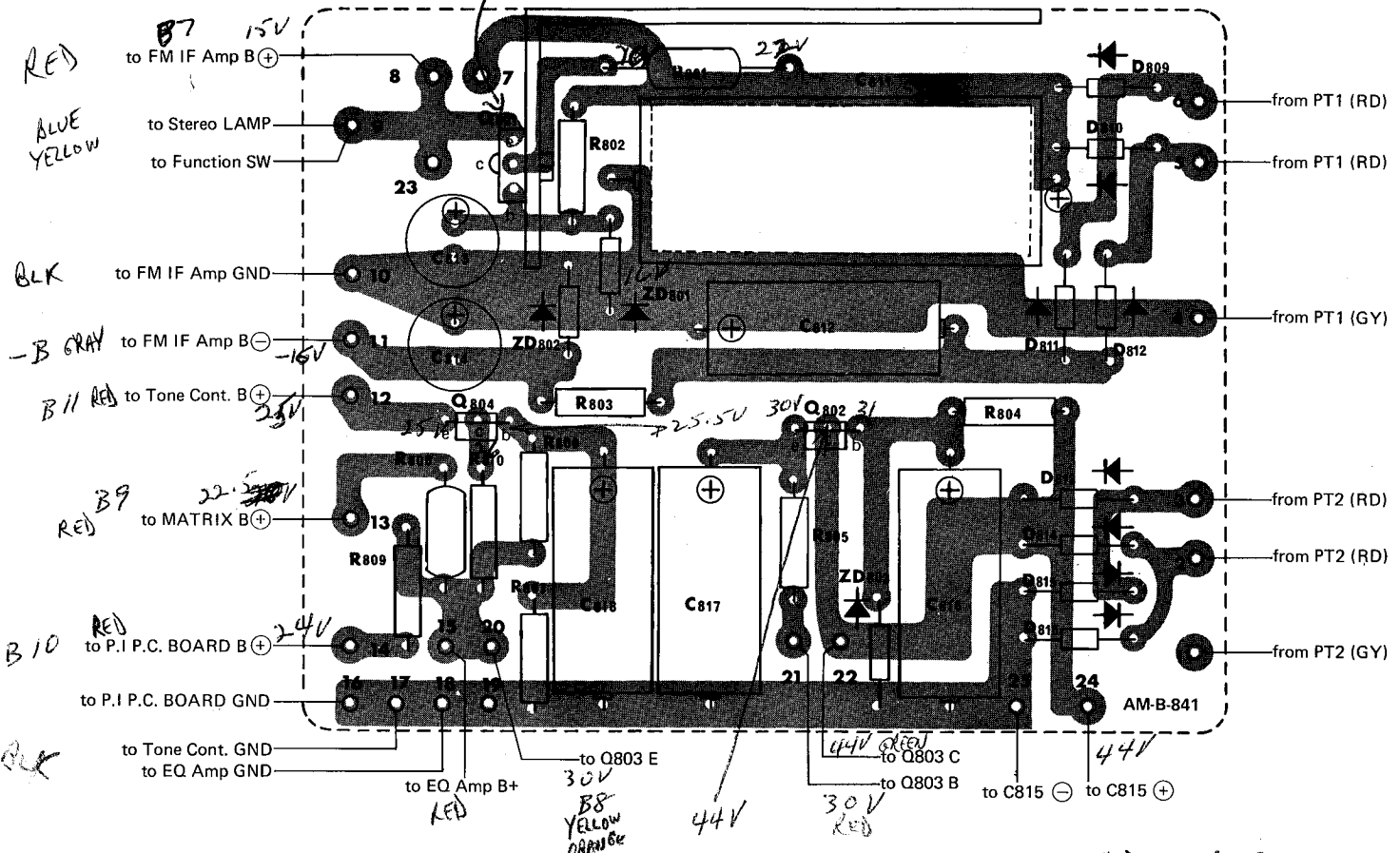

C812, C816, C817, C818
100µF/35V
31519120

CLAMP BOARD

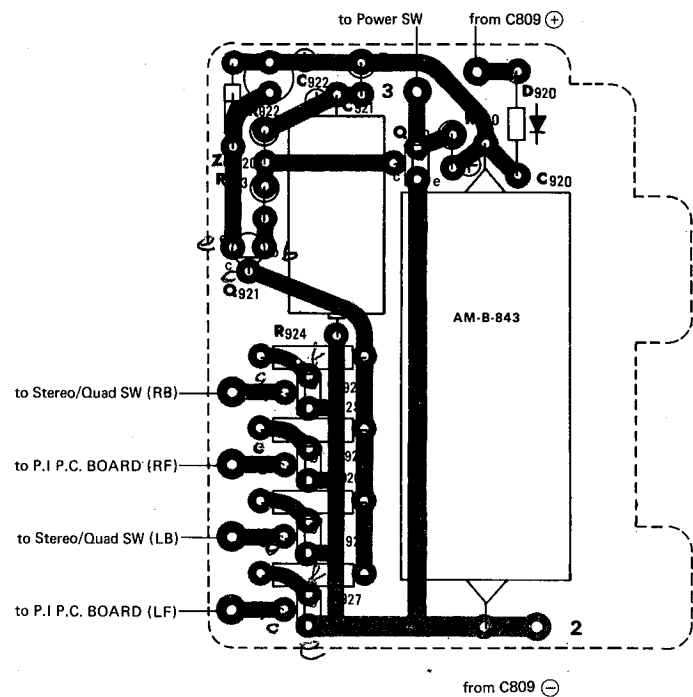

MATRIX BOARD

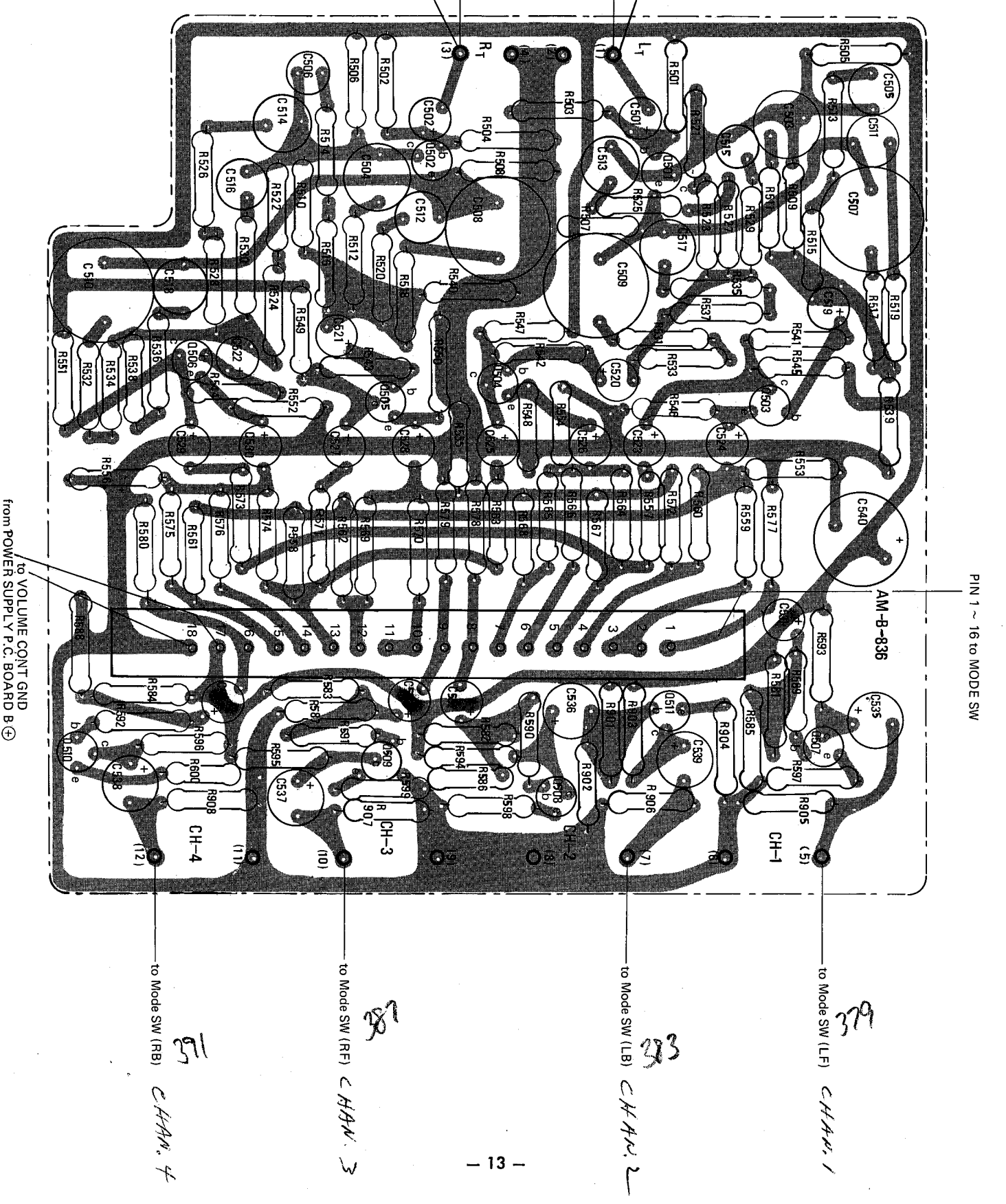

PIN 1 ~ 16 to MODE SW

TOP VIEW

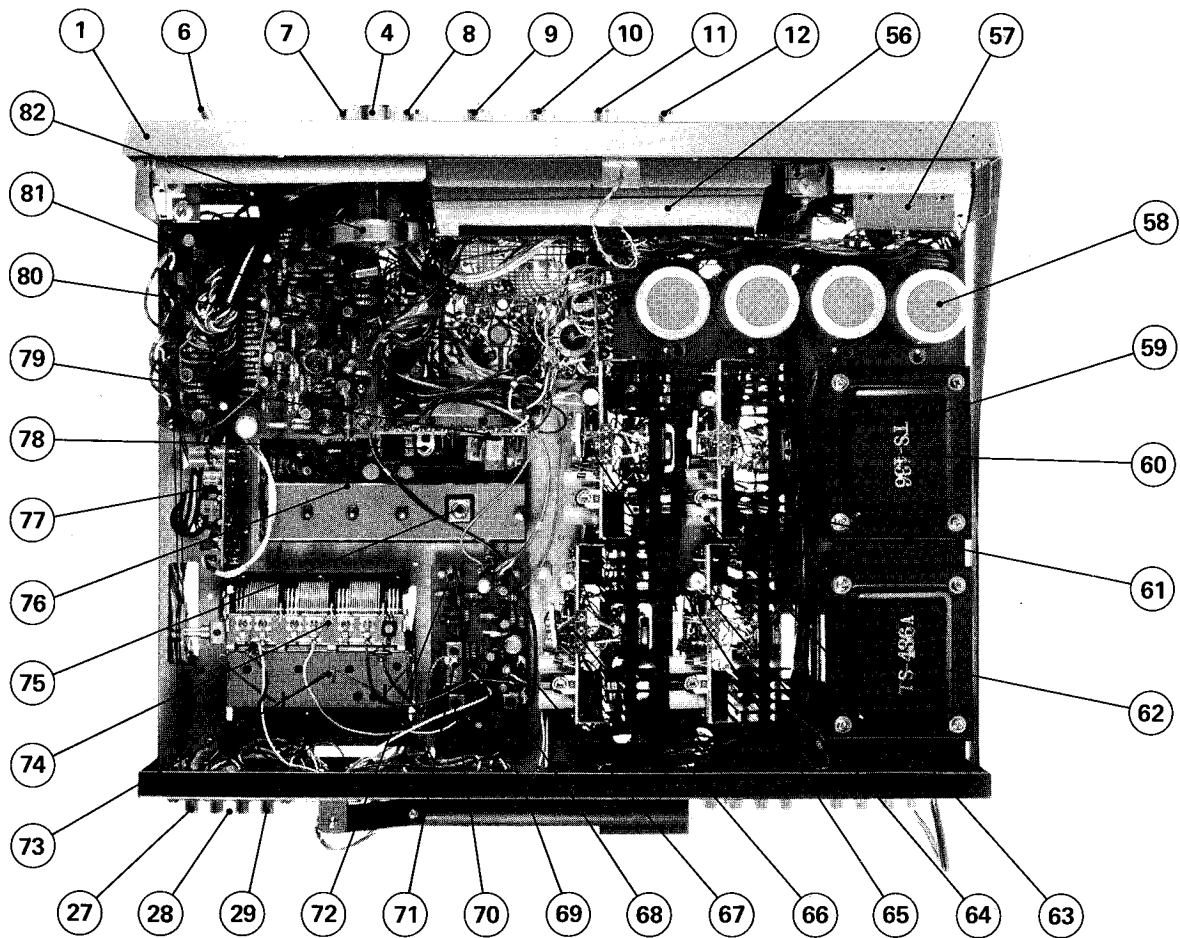

- | | | | |
|----|-------------------------------------|----|--------------------------|
| ⑤⑥ | DIAL LAMP HOUSE | ⑦⑩ | AM OSC COIL (L53) |
| ⑤⑦ | METER LAMP HOUSE | ⑦① | AM I.F.T (IFT51) |
| ⑤⑧ | RIPPLE FILTER CAPACITOR (C807-C810) | ⑦② | AM METER ADJ (VR53) |
| ⑤⑨ | POWER TRANSFORMER 1 | ⑦③ | FM FRONT END |
| ⑥⑩ | POWER TRANSISTOR | ⑦④ | V.C |
| ⑥① | IDLING ADJ (VR751) | ⑦⑤ | FM I.F.T (IFT101, |
| ⑥② | POWER TRANSFORMER 2 | ⑦⑥ | FM IF P.C.B |
| ⑥③ | POWER AMP P.C.B (R _F) | ⑦⑦ | PHONO PRE AMP P.C.B |
| ⑥④ | POWER AMP P.C.B (R _B) | ⑦⑧ | 19 KHz LEVEL ADJ (VR302) |
| ⑥⑤ | POWER AMP P.C.B (L _F) | ⑦⑨ | M.P.X P.C.B |
| ⑥⑥ | POWER AMP P.C.B (L _B) | ⑧① | TONE P.C.B |
| ⑥⑦ | AM OUTPUT ADJ (VR52) | ⑧② | MATRIX P.C.B |
| ⑥⑧ | AM RF COIL (L52) | | FLY WHEEL |
| ⑥⑨ | AM TUNER P.C.B | | |

BOTTOM VIEW

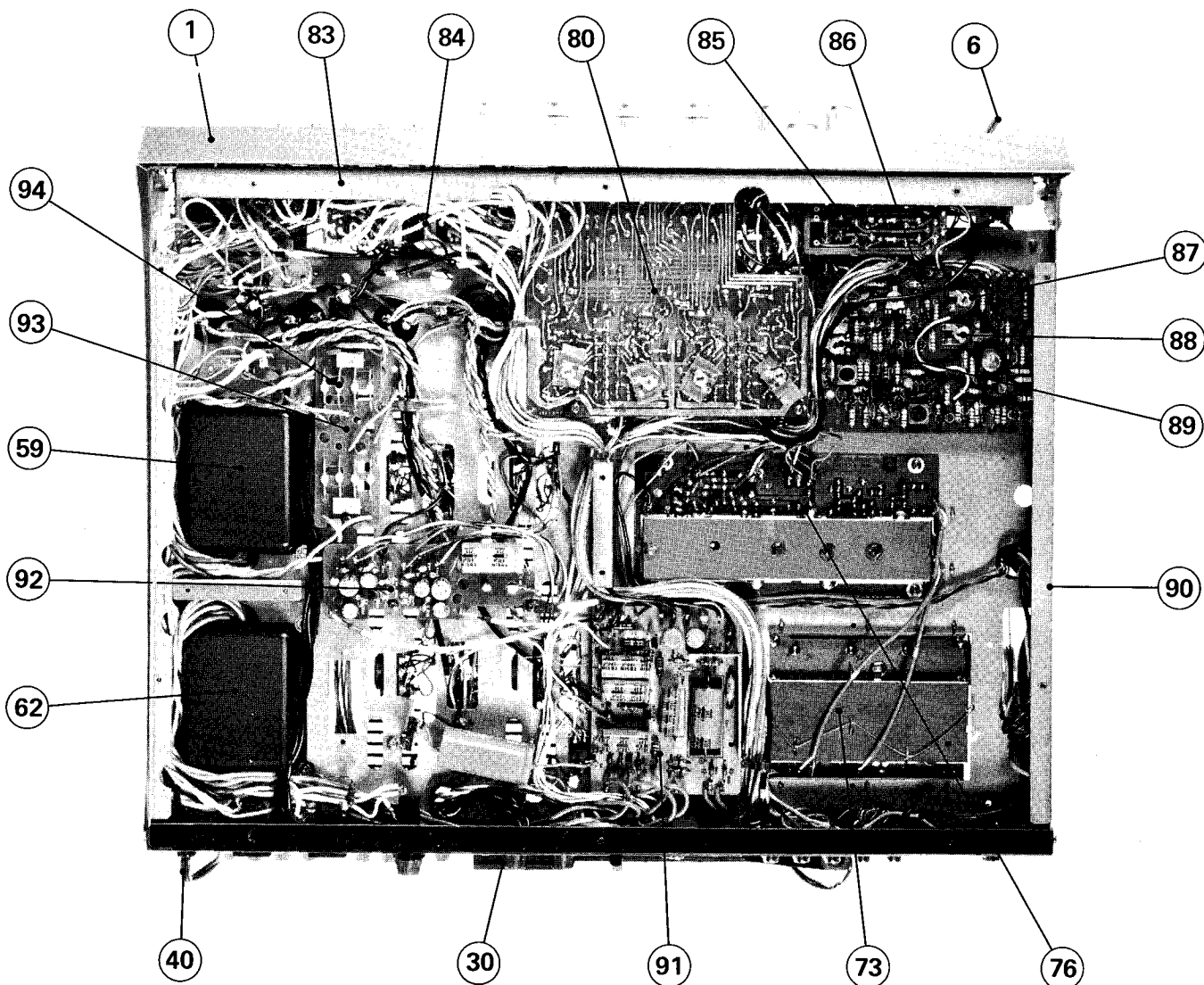

- | | | | |
|----|-----------------------------------|----|--------------------------|
| ⑧③ | FRONT CHASSIS | ⑧⑨ | MUTING LEVEL ADJ (VR201) |
| ⑧④ | PUSH SWITCH P.C.B | ⑨① | VOLTAGE STABILIZER P.C.B |
| ⑧⑤ | VOLUME P.C.B | ⑨② | PHASE INVERTER P.C.B |
| ⑧⑥ | METER CIRCUIT P.C.B | ⑨③ | RECTIFIER P.C.B |
| ⑧⑦ | FM METER ADJ (VR202) | ⑨④ | RECTIFIER (D801-D808) |
| ⑧⑧ | STEREO/MONO THRESHOLD ADJ (VR203) | | |

BLOCK DIAGRAM — MODEL 150 +

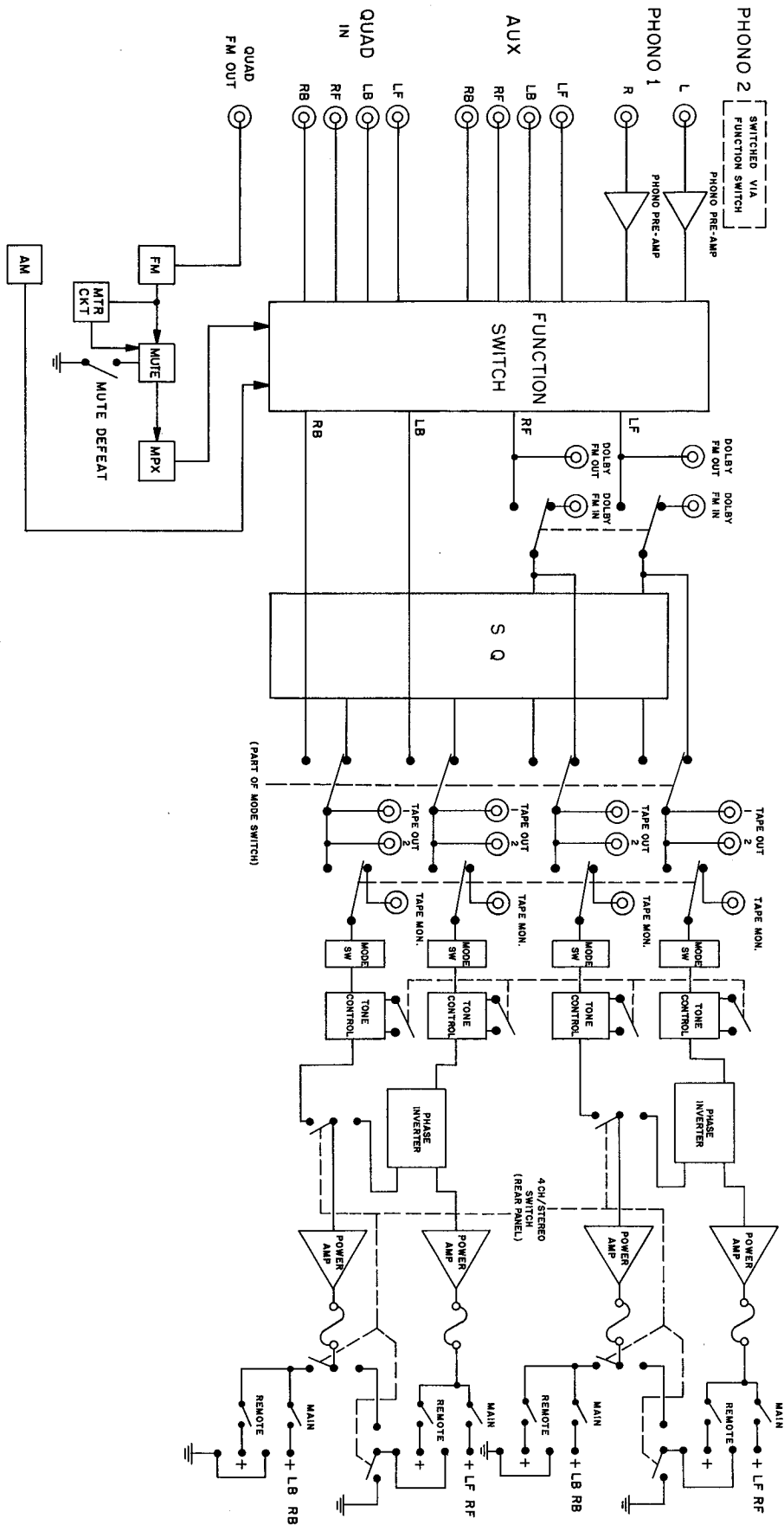

METER CIRCUIT BLOCK DIAGRAM

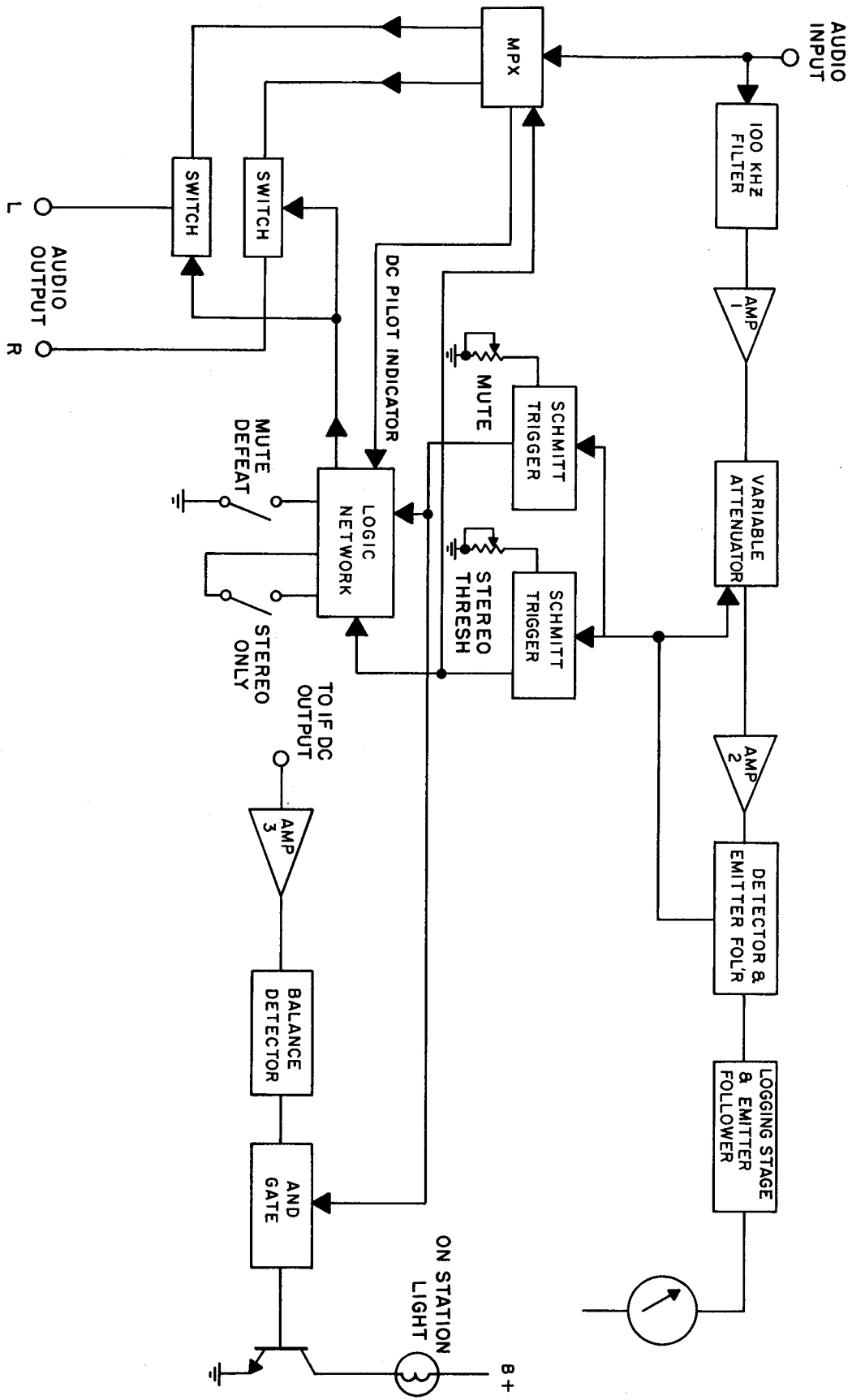

QUIETING METER BOARD

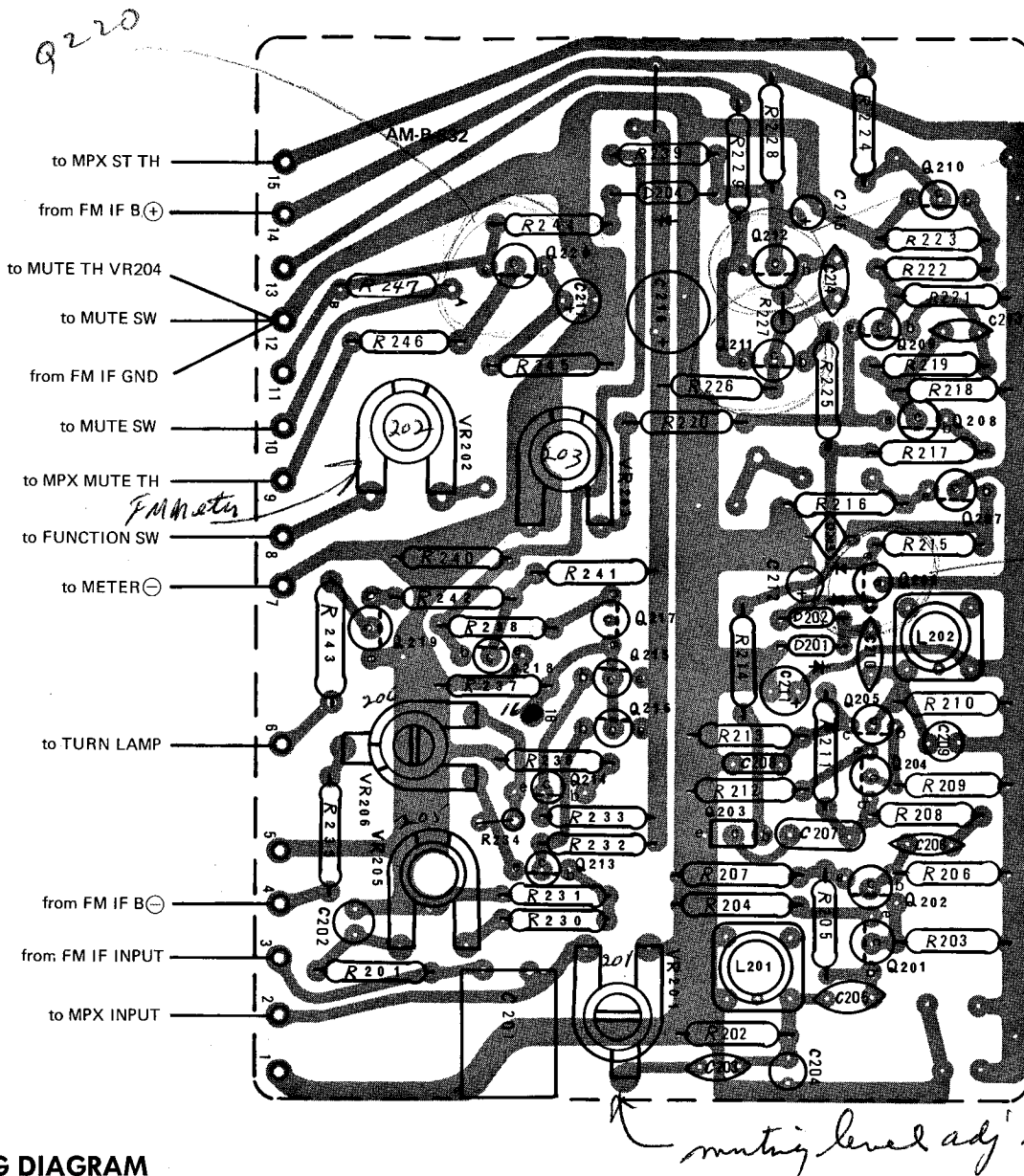

STRINGING DIAGRAM

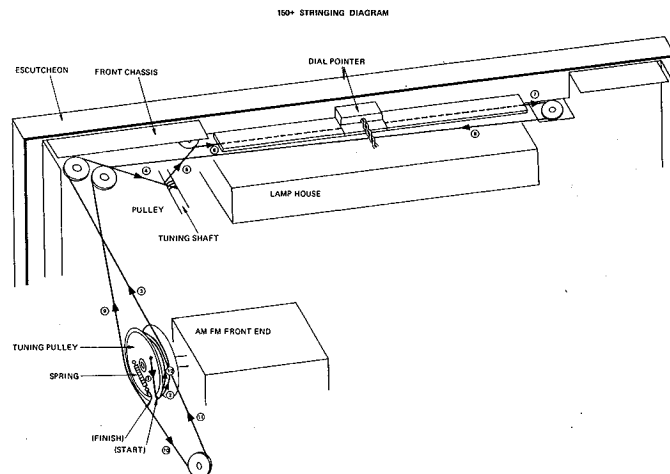

REPLACEMENT PARTS LIST

HK PART NO.	REF. NO.	DESCRIPTION	HK PART NO.	REF. NO.	DESCRIPTION
TRANSFORMERS			TRANSISTORS & IC'S (Cont.)		
11029040	IFT 51	Transformer, IF	43025972	Q501-511	Transistor (2SC374BL)
11029041	IFT	Transformer, IF (10.7MHz)	43025972	Q601-612	Transistor (2SC693GU)
11029042	IFT 101	Transformer, IF (13mm/ 10.7MHz)	43026284	Q753	Transistor (2SC959M)
10129031	T1	Power Transformer	43026284	Q754	Transistor (2SC960)
10129032	T2	Power Transformer	43026285	Q755	Transistor (2SA607)
COILS			43024216	Q756/757	Transistor (2SD322K)
12029043	L 1	Antenna Coil (75 Ohm)	43027213	Q801	Transistor (2SC1368DM)
12029044	2/3	Tuning Coil (2½ T)	43028974	Q803	Transistor (2SC1016CM)
12029045	4	Oscillating Coil (1¼ T)	38129008	VS751	Varistor (HV-46 (Red))
12029046	5/54/101/103	Choke Coil (2.2µH)	DIODES		
12029047	51	Bar Antenna Coil	41029009	D51-53	Diode, IN34A
12029048	52	Tuning Coil	41028750	D101-104	Diode, IS188FM
12029049	53	Oscillator Coil	41022859	D201/202/203/204	Diode, IN4154
12029050	104	Choke Coil	42029013	D751/920	Diode, Zener (5V)
12029051	105	Choke Coil	41029015	D752/753/809-815	Diode, 2A100
12029052	201/202	Tuning Coil (10mm/3.3µH)	41029014	D801-808	Diode U05B, 3A200
12029057	301/303	Tuning Coil MPX 38kHz	42029017	ZD801/802	Diode, Zener
12029058	302	Tuning Coil MPX 19kHz	42029018	ZD803	Diode, Zener (31V)
12029053	304/306	Tuning Coil MPX 19kHz Filter	CONTROLS & SWITCHES		
12029054	305/307	Tuning Coil MPX 38kHz Filter	23528991	VR204	Control, Muting, 500 Ohm B Type
12029055	601/604	Choke Coil (200mH)	23028992	VR601	Control, Volume, 100K
12029056	CH751	Choke Coil (30µH)	23028993	VR602	Control, Bass, 100K
TRANSISTORS & IC'S			23028994	VR603	Control, Treble, 200K
43128975	IC103	IC, LA 1111	23028995	VR604	Control, Mid Range, 20K
43128741	IC101/102	IC, LA 1221	00229000	V605/205	Control, Balance 50K W Type
43126551	IC301	IC, MC-1307P	23528996	VR51	Pot, 200K, B Type
43128976	IC51	IC, UOC, 30C	23528997	VR52	Pot, 2K, B Type
43025972	Q51	Transistor (2SC460CM)	23528998	VR53/202	Pot, 10K, B Type
43025972	Q52/302/303 Q701/702/752	Transistor (2SC945Q)	23528999	VR101/206	Pot, 1K, B Type
43025972	Q101/105	Transistor (2SC930D)	23529001	VR102/601-604	Pot, 20K, B Type
43025972	Q102/103	Transistor (2SC715)	23529002	VR201	Pot, 10K, B Type
43027722	Q104	Transistor (2SA608)	23529003	VR203/302	Pot, 200 Ohm, B Type
43025972	Q203	Transistor (2SC458B)	23529004	VR301	Pot, 50K, B Type
43025972	Q213/214	Transistor (2SC715E)	23529005	VR751	Pot, 5K, B Type
43027722	Q215/216/921	Transistor (2SA608G)	24528725	S1	Switch, 4CH/Stereo
43025972	Q217-220	Transistor (2SC715G)	25029006	S2/4/6/8/10	Switch Bank (5) Top <i>6.55</i>
43025972	Q301	Transistor (2SC454CM)	25029007	S3/5/7/9/11	Switch Bank (5) Bottom <i>7.15</i>
43028972	Q304	Transistor (TSC90023C)	24028730	S12	Switch - Mode (Rotary)
43028973	Q401/402	Transistor (BC239C)	24028729	S13	Switch - Function (Rotary)
43025972	Q403-406/802/ 804	Transistor (2SC458CM)	25028726	S14	Switch - AC
		<i>USE 5972 for Q 920</i>			

HK PART NO.	REF. NO.	DESCRIPTION
MISCELLANEOUS		
00229022		AM/FM Tuner
00129019		Escutcheon Assy Consists Of
63028902		Escutcheon
63029020		Gold Insert (Bal. Control Area)
63029021		Gold Insert (Control Area)
61628977		Top Panel (Tinted Plexiglas)
63028705		Dress Ring (Balance Control)
61028689		Dial Scale (Plexiglas)
63228978		Knob, Balance Control
63228698		Knob, Volume, Function, Mode
63228701		Knob (Front), Bass, Treble, Mid Range
63228702		Knob (Back), Bass, Treble, Mid Range
63228699		Knob, Tuning
63228700		Knob, Pushbuttons (Gold)
63228979		Knob, Power Switch (Red)
46528980	LA201/301	Bulb, 15V-70mA, Stereo, In Tune
46528981	LA011/010	Bulb, 10V-150mA, Meter

HK PART NO.	REF. NO.	DESCRIPTION
MISCELLANEOUS (Cont.)		
46528982	LA001/002-005	Bulb, Power, Mode (1-4-2-4)
46528980	LA014	Bulb, 10V-70mA, Pointer
46528903	LA006-009	Bulb, 10V, 300mA, Dial
60728984		Dial Pointer
00228709		Flywheel/Tuning Shaft Assy.
12528985		Meter, Quieting
65428734		Headphone Jack
65428716		Fuse Holder
45028865		Fuse 5A-3AG
53028720		Power Cord
65428719		AC Outlet
00228986		AM Loopstick Assy w/Mtg Bkt
65428987		Receptacle (RCA Type) 1 Pin
65428988		Receptacle (RCA Type) 4 Pin
65428989		Receptacle (RCA Type) 10 Pin
65428990		Ant/Speaker Terminal, 4 Screw
60128901		Top Cover
62028695		Plastic Foot
90728190		Instruction Manual
90129023		Carton & Fillers
90728933		Schematic, 150+

46528737

NOTE: To speed handling of your order be sure to include both the model and serial numbers which appear at the back of the chassis, in addition to the quantity, part number and part description of the items ordered. Orders from independent dealers, independent servicemen, and retail customers will be shipped on a cash in advance basis. Harman-Kardon reserves the right to substitute equivalent parts for those originally installed in this chassis. All parts should be ordered from Harman-Kardon, 55 Ames Court, Plainview, L.I., N.Y. 11803, Att: Parts Department.