harman/kardon
Service Manual

HK 3490/230

2 x 120W STEREO RECEIVER



CONTENTS

LEAKAGE CHECK	2	EXPLODED VIEW AND PARTS	13
ESD WARNING	3	ELECTRICAL PARTS LIST	14
TECHNICAL SPECIFICATIONS	4	SEMICONDUCTOR PINOUTS	34
TROUBLESHOOTING GUIDE	5	PCB DRAWINGS	58
FRONT PANEL CONTROLS	6	BLOCK DIAGRAM	64
REAR PANEL CONNECTIONS	7	WIRING DIAGRAM	65
PACKAGE LIST AND PARTS	8	AMP BIAS ADJUSTMENT	66
DISASSEMBLY	9	SCHEMATIC DIAGRAMS	67

SAFETY PRECAUTIONS

The following check should be performed for the continued protection of the customer and service technician.

LEAKAGE CURRENT CHECK

Measure leakage current to a known earth ground (water pipe, conduit, etc.) by connecting a leakage current tester between the earth ground and all exposed metal parts of the appliance (input/output terminals, screwheads, metal overlays, control shaft, etc.). Plug the AC line cord of the appliance directly into a 120V AC 60Hz outlet and turn the AC power switch on. Any current measured must not exceed 0.5mA.

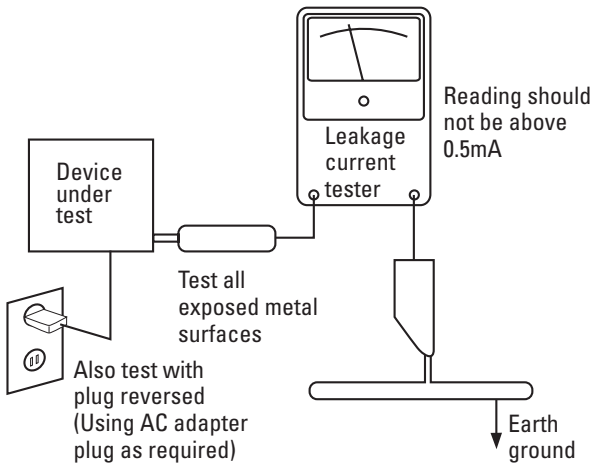

AC Leakage Test

ANY MEASUREMENTS NOT WITHIN THE LIMITS OUTLINED ABOVE ARE INDICATIVE OF A POTENTIAL SHOCK HAZARD AND MUST BE CORRECTED BEFORE RETURNING THE APPLIANCE TO THE CUSTOMER.

ELECTROSTATICALLY SENSITIVE (ES) DEVICES

Some semiconductor (solid state) devices can be damaged easily by static electricity. Such components commonly are called Electrostatically Sensitive (ES) Devices. Examples of typical ES devices are integrated circuits and some field effect transistors and semiconductor "chip" components.

The following techniques should be used to help reduce the incidence of component damage caused by static electricity.



1. Immediately before handling any semiconductor component or semiconductor-equipped assembly, drain off any electrostatic charge on your body by touching a known earth ground. Alternatively, obtain and wear a commercially available discharging wrist strap device, which should be removed for potential shock reasons prior to applying power to the unit under test.
2. After removing an electrical assembly equipped with ES devices, place the assembly on a conductive surface such as aluminum foil, to prevent electrostatic charge build-up or exposure of the assembly.
3. Use only a grounded-tip soldering iron to solder or unsolder ES devices.
4. Use only an anti-static solder removal device. Some solder removal devices not classified as "anti-static" can generate electrical charges sufficient to damage ES devices.
5. Do not use freon-propelled chemicals. These can generate electrical change sufficient to damage ES devices.
6. Do not remove a replacement ES device from its protective package until immediately before you are ready to install it. (Most replacement ES devices are packaged with leads electrically shorted together by conductive foam, aluminum foil or comparable conductive material.)
7. Immediately before removing the protective material from the leads of a replacement ES device, touch the protective material to the chassis or circuit assembly into which the device will be installed.

CAUTION : Be sure no power is applied to the chassis or circuit, and observe all other safety precautions.

8. Minimize bodily motions when handling unpackaged replacement ES devices. (Otherwise harmless motion such as the brushing together of your clothes fabric or the lifting of your foot from a carpeted floor can generate static electricity sufficient to damage an ES devices.

PRODUCT SAFETY NOTICE

Each precaution in this manual should be followed during servicing.

Components identified with the IEC symbol  in the parts list are special significance to safety. When replacing a component identified with , use only the replacement parts designated, or parts with the same ratings or resistance, wattage, or voltage that are designated in the parts list in this manual. Leakage-current or resistance measurements must be made to determine that exposed parts are acceptably insulated from the supply circuit before returning the product to the customer.

Technical Specifications

Audio Section

Stereo Mode

Continuous Average Power (FTC)

HK 3490: 120 Watts per channel, 20Hz–20kHz

@ < 0.07% THD, both channels driven into 8 ohms

HK 3390: 80 Watts per channel, 20Hz–20kHz@ < 0.07% THD, both channels driven into 8 ohms

Input Sensitivity/Impedance

Linear (High Level) 200mV/47kohms

Signal-to-Noise Ratio (IHF-A) 95dB

Frequency Response

@ 1W (+0dB, -3dB) 10Hz–110kHz

High Instantaneous

Current Capability (HCC)

HK 3490: ±45Amps

HK 3390: ±42Amps

Transient Intermodulation

Distortion (TIM)

Unmeasurable

Rise Time

16 µsec

Slew Rate

40V/µsec

FM Tuner Section

Frequency Range

87.5–108MHz

Usable Sensitivity

IHF: 1.3µV/13.2dBf

Signal-to-Noise Ratio

Mono/Stereo: 73/72dBA (DIN)

Distortion

Mono/Stereo: 0.2/0.3%

Stereo Separation

40dB @ 1kHz

Selectivity

±400kHz, 65dB

Image Rejection

>80dB

IF Rejection

>100dB

AM Tuner Section

Frequency Range

522–1620kHz

Signal-to-Noise Ratio

>40dB

Usable Sensitivity

Loop: 500µV/M

Distortion

1kHz, 50% Mod: 0.8%

Europe:

±9kHz

Video Section

Television System

NTSC/PAL/SECAM

Signal Format

Composite

Input Level

1Vp-p

Input Impedance

75 ohms, unbalanced

Sync Polarity

Negative

Output Level

1Vp-p

Output Impedance

75 ohms, unbalanced

Video Frequency

Response

10Hz – 10MHz

General

Power Requirement

AC 230V/50Hz

Power Consumption

HK 3490: 3W standby, 310W maximum
(both channels driven)HK 3390: 3W standby, 230W maximum
(both channels driven)

Dimension (Max)

Width

440mm

Height

165mm

Depth

382mm

Weight

HK 3490: 10.4kg

HK 3390: 9.5kg

Depth measurement includes knobs, buttons and terminal connections. Height measurement includes feet and chassis.

All features and specifications are subject to change without notice.

Harman Kardon and Power for the Digital Revolution are registered trademarks of Harman International Industries, Incorporated.

Troubleshooting Guide

This unit is designed for trouble-free operation. Most problems users encounter are due to operating errors. If you have a problem, first check this list for a possible solution. If the problem persists, consult your authorized Harman Kardon Service Center.

If the problem is...	Make sure that the...
No lights appear when System Power 2 button is pressed	Unit is plugged into a live outlet.
No sound is heard	Unit has not been muted. Correct input function selector button has been pressed. Volume is turned up. Speakers have been turned on using the Speaker Selectors 6 7 U V .
No output from one or more channels	Cables are not defective: check/replace speaker cables.
Tuner sound has a large amount of interference, or the "Stereo" display is not illuminated, or Tuner sound distorts and/or is noisy	Antenna is properly connected. Antenna is properly located. Antenna is set in the proper direction. Antenna is adequate to receive the desired station.
Tuner is intermittent or continuously buzzing or hissing	Unit is away from fluorescent lights, TVs, motors and other electrical appliances.
Remote does not function correctly	Batteries are not weak, and replace them if necessary. Correct device page has been selected by pressing the Source Selector key G . Remote sensor is not obstructed, and remote is pointing directly at sensor at an angle of no more than 30 degrees. Also, check for fluorescent lighting, which may be interfering with the IR transmission.
Cassette or CD sounds distorted	Cassette deck or CD player has not been plugged into the Phono input. (Only use the outputs of a turntable or tonearm with the Phono input.)
Turntable sounds distorted	Turntable has been plugged into the Phono Input 6 , as the other inputs are not compatible with turntable signal levels
No video image	Video source unit's video output is properly connected, the source is turned on and the correct video input on the HK 3490/HK 3390 has been selected Video Monitor Output 21 is connected to a TV or video display, and that the TV is turned on and the proper input on the TV has been selected

Front Panel Controls

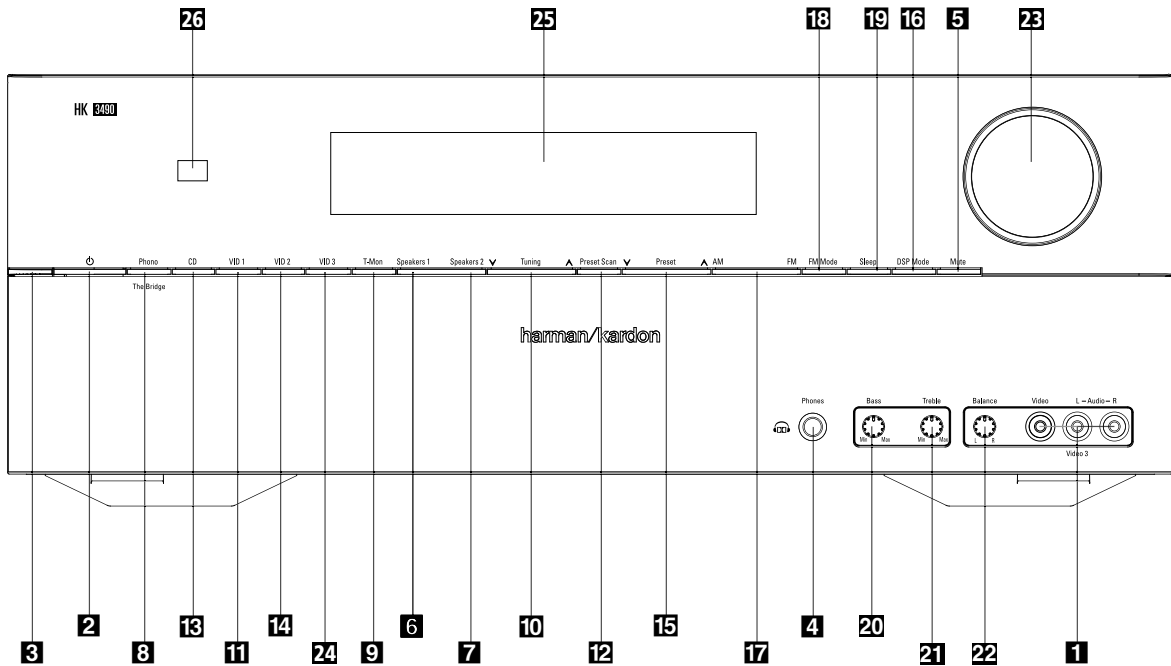

- 1** Video 3 input jacks
- 2** System Power Control
- 3** Power Indicator
- 4** Headphone Jack
- 5** Mute
- 6** Speaker 1 Selector
- 7** Speaker 2 Selector
- 8** Phone Input Selector
(The Bridge/Phono Input Selector HK 3490 only)
- 9** Tape Monitor Input Selector

- 10** Tuning Button
- 11** Video 1 Input Selector
- 12** Preset Scan
- 13** CD Input Selector
- 14** Video 2 Input Selector
- 15** Preset Selector
- 16** DSP Function Selector (HK 3490 only),
Dimmer Switch (HK 3390 only).
- 17** FM/AM Selector
- 18** FM Mode Selector

- 19** Sleep Button
- 20** Bass Control
- 21** Treble Control
- 22** Balance Control
- 23** Volume Control
- 24** Video 3 Input Selector
- 25** Information Display
- 26** Remote Sensor Window

1 Video 3 Input Jacks: These audio/video jacks may be used for temporary connection to video games or portable audio/video products such as camcorders and portable audio players.

To select the front-panel inputs, press the **Video 3 Input Selector 24** repeatedly until the Information Display shows the text "VIDEO F / ANALOG". When using the rear panel inputs, the Display shows "VIDEO 3 / ANALOG".

2 System Power Control: When the **Main Power Switch 29** is "ON," press this button to turn on the HK 3490/HK 3390; press it again to turn the unit off (to Standby). Note that the **Power Indicator 3** changes color from amber to white when the unit is on.

3 Power Indicator: This LED will illuminate in amber when the unit is in the Standby mode to signal that the unit is ready to be turned on. When the unit is in operation, the indicator will turn white. A red indicator means that the unit is in the Protect mode, and should be turned off and then checked for a possible speaker wire short circuit.

4 Headphone Jack: This jack may be used to listen to the HK 3490/HK 3390's output through a pair of headphones. Be certain that the headphones have a standard 6,3 mm stereo phone plug. When a headphone is connected, the Speakers 1 and Speakers 2 Selectors are inactive.

5 Mute: Press this button to momentarily silence the speaker and preamp output of the HK 3490/HK 3390.

6 Speakers 1 Selector: Press this button to turn the speakers connected to the **Speaker 1** output terminals **17** on or off.

7 Speakers 2 Selector: Press this button to turn the speakers connected to the **Speaker 2** output terminals **18** on or off.

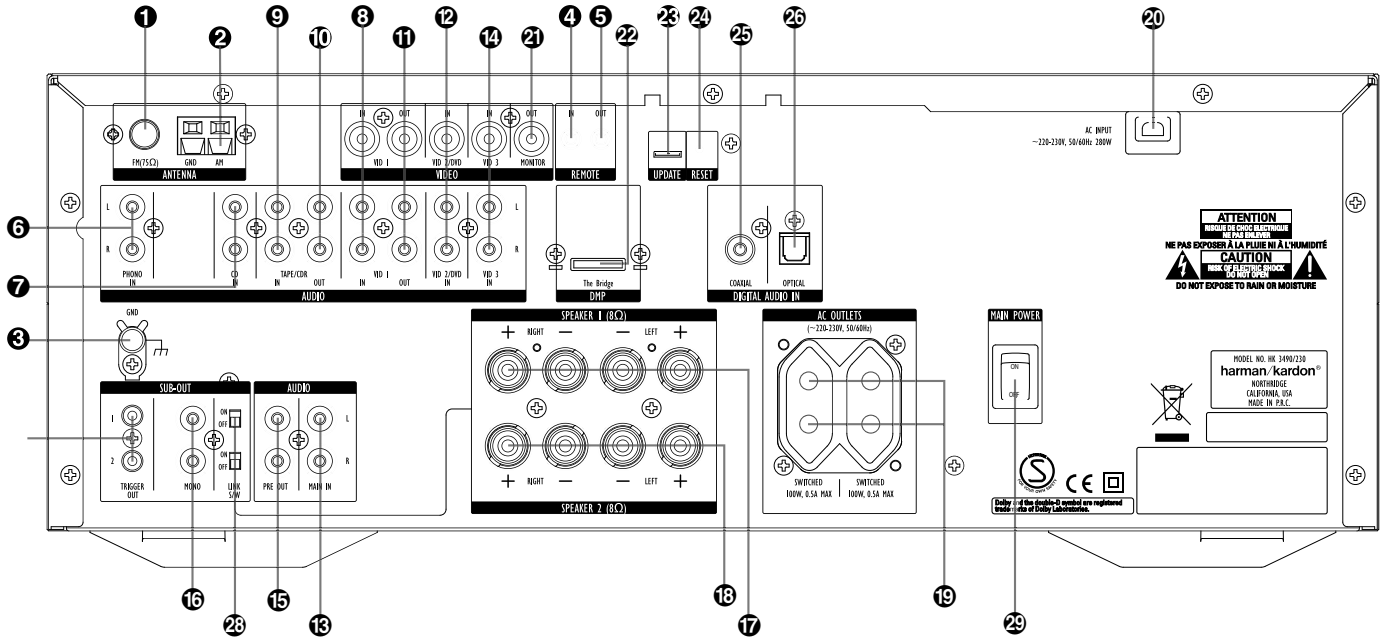

- ❶ AM Antenna
- ❷ FM Antenna
- ❸ Phono Ground
- ❹ Remote IR In
- ❺ Remote IR Out
- ❻ Phono Inputs
- ❼ CD Inputs
- ❽ Video 1 Audio/Video Play/In
- ❾ Tape Monitor Play/In
- ❿ Tape Monitor Record/Out

- ⓫ Video 1 Audio/Video Record/Out
- ⓬ Video 2 Audio/Video Inputs
- ⓭ Main In
- ⓮ Video 3 Audio/Video Inputs
- ⓯ Preamp Out
- ⓰ Subwoofer Out
- ⓱ Speaker 1 Terminals
- ⓲ Speaker 2 Terminals
- ⓳ Switched AC Outlet
- ⓴ Power Cable

- ⓴ Video Monitor Outputs
- ⓶ The Bridge Input (HK 3490 only)
- ⓷ Update Cable Input
- ⓸ Reset Switch
- ⓹ Coaxial Digital Audio Input (HK 3490 only)
- ⓺ Optical Digital Audio Input (HK 3490 only)
- ⓻ Subwoofer Trigger Outputs
- ⓼ Subwoofer Link On/Off Switches
- ⓽ Main On/Off Switch

1. Instruction manual ass'y - Accessories

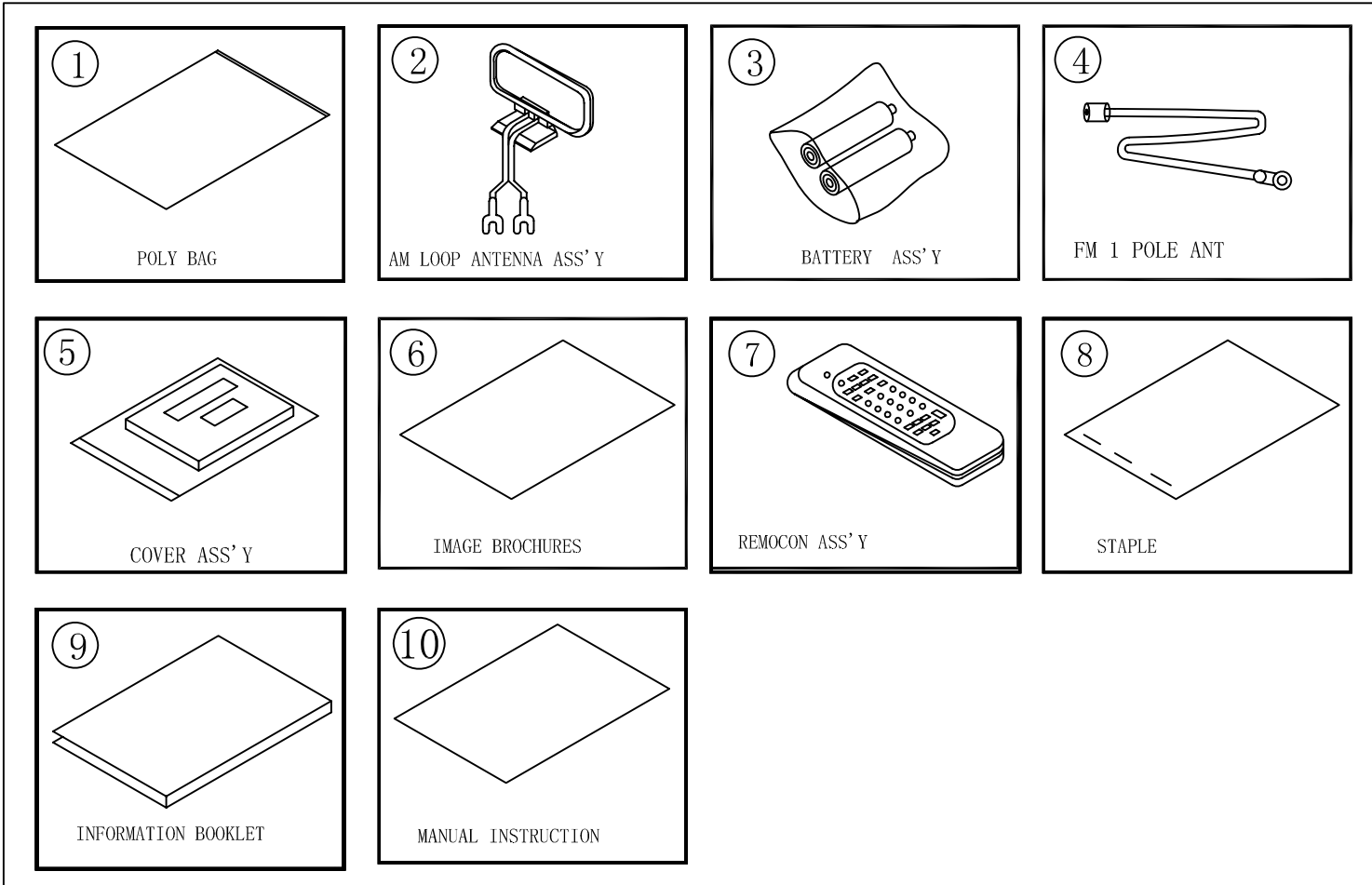

2. Package Drawing

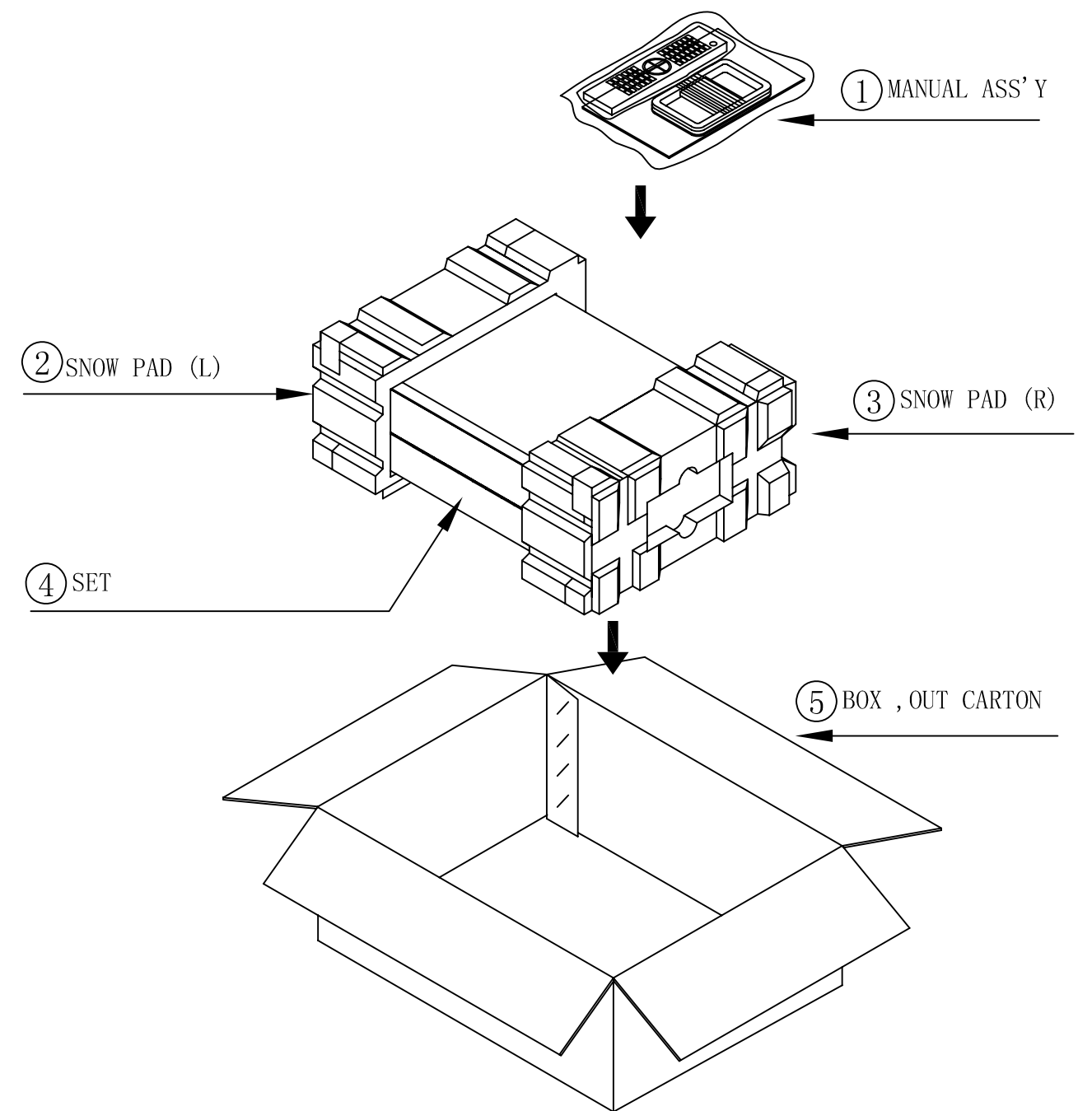

ACCESSORY-1			
NO	DESCRIPTION	PARTS NO.	Q, ty
1	POLY BAG	CPB1061W	1
2	AM LOOP ANTENNA ASS' Y	CSA1A027Z	1
3	BATTERY	CABR03P	2
4	FM 1 POL ANT	CSA1A018Z	1
5	COVER ASS' Y	CGRHK3390/230ZA	1
	1 COVER A	CGR1A445	1
	2 COVER B	CGR1A446	1
	3 ORNAMENT , AL A	CGX1A391C66	1
	4 ORNAMENT , AL B	CGX1A392C66	1
	5 SHEET, FRONT COVER	CQE1A393Z	1
	6 PAD , COVER	CPS1A676	1
	7 BAG , POLY	CPB1A176Z	1
6	IMAGE BROCHURES	HQE1A273Z	1
7	REMOCON ASS' Y	CARTHK3490/230	1
8	STAPLE	CPL0905	3
9	BOOKLET , INFORMATION	CQE1A180Z	1
10	MANUAL, INSTRUCTION	CQX1A1329Z	1

NO	DESCRIPTION	PARTS NO.	Q, ty
1	ACCESSORY-1	CQXHK3490/230	1
2	SNOW, PAD(L)	CPS5A564	1
3	SNOW, PAD(R)	CPS5A565	1
4	SET	HK3490/230SET	1
5	BOX, OUT CARTON	CPG1A743N	1

DISASSEMBLY

HK3490/230

1. Removing the Top Cabinet
Remove the Screws ①~⑬

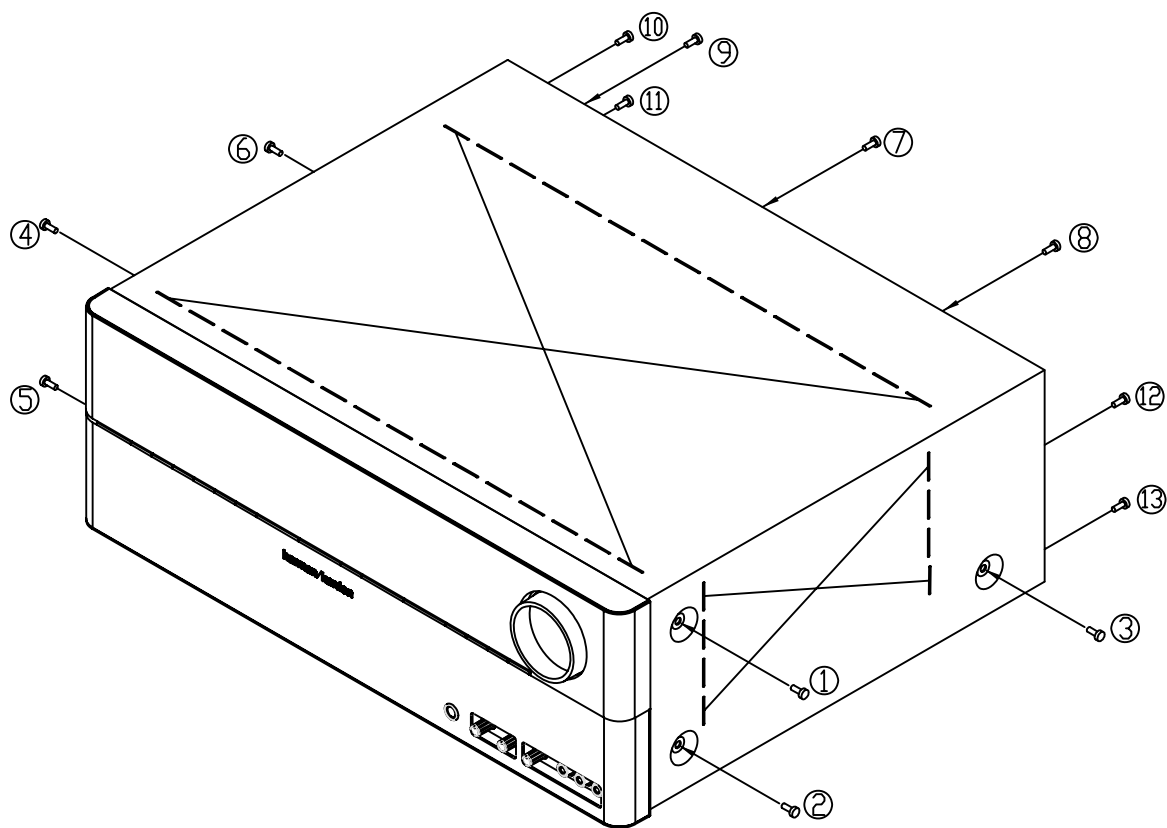

2. Removing the Front Panel
Remove the Screws ①~⑨

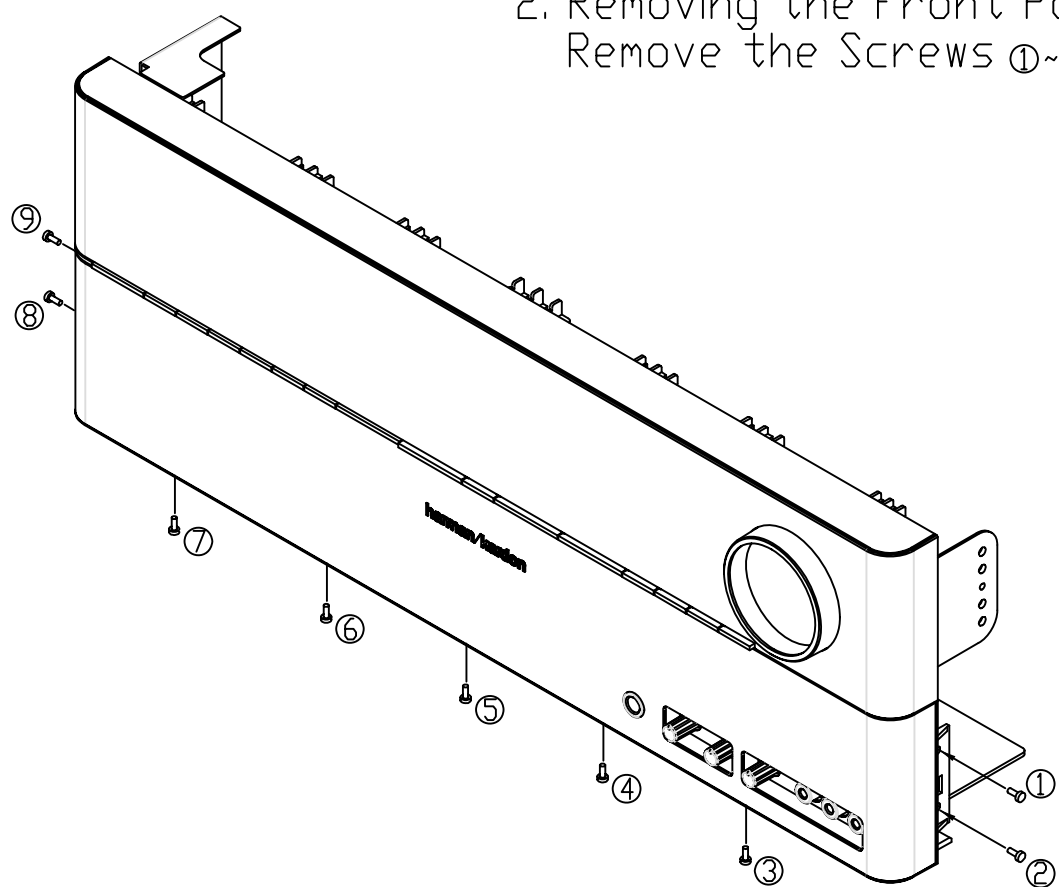

3. Removing the Rear Panel
Remove the Screws ①~⑮

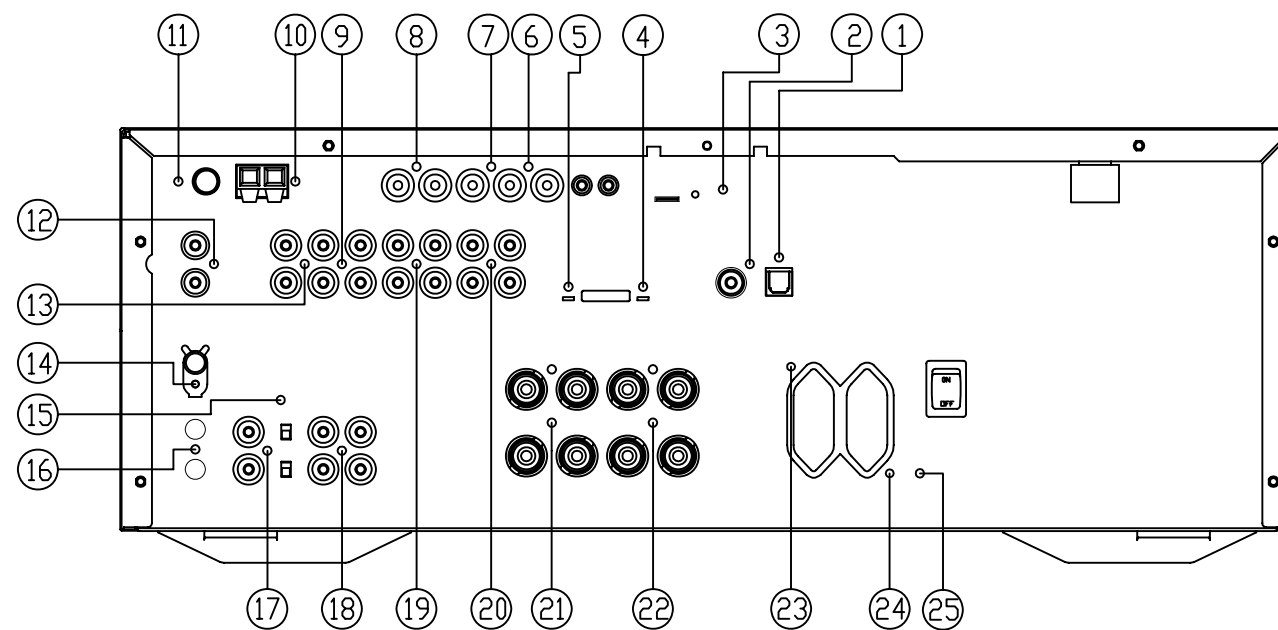

4. Removing the Main PCB
Remove the Screws ①~⑤

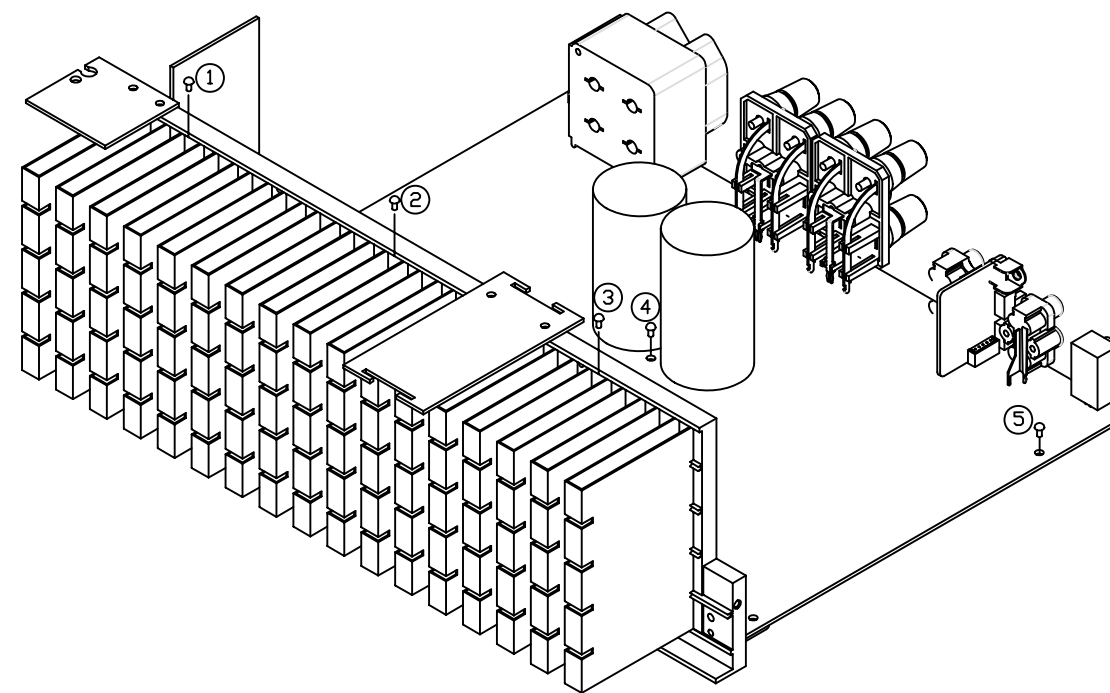

HK 3490 DISASSEMBLY PROCEDURES

<1> TOP-CABINET(21) REMOVAL

1. Remove 13 screws(S1) and then remove the Top-cabinet.

<2> FRONT PANEL ASS'Y REMOVAL

1. Remove the Top-cabinet, referring to the previous step<1>.
2. Disconnect the lead wire(BN22-11P) on the Potentiometer PCB (43-4) from connector(CN22) on the Input PCB(45).
3. Disconnect the lead wire(BN13-9P) on the Front PCB(43-1) from connector(CN13) on the Main PCB(44-1).
4. Disconnect the connector(CN87-19P) on the Front PCB(43-1) from connector(CN87) on the Main PCB(44-1).
5. Disconnect the lead wire(BN73-5P) on the Phone PCB(43-3) from connector(CN73) on the Main PCB(44-1).
6. Disconnect the lead wire(BN84-5P) on the Front input video PCB(43-6) from connector(CN84) on the Input PCB(45).
7. Remove 1 screw(S6) and then lead wire(JW98,JW99-1P) on the PCB(43-5, 43-3).
8. Remove 1 screw(S6) and then lead wire(JW97-1P) on the Power led PCB(43-2).
9. Remove 10 screws(S1) and then remove the Front Panel ASS'Y.

<3> Potentiometer PCB(43-4) REMOVAL

1. Remove the Top-cabinet, referring to the previous step<1>.
2. Remove the Front Panel ASS'Y, referring to the previous step<2>.
3. Remove 2 screws(S3) and then remove the Potentiometer PCB(43-4).

<4>PHONE PCB(43-3) REMOVAL

1. Remove the Top-cabinet, referring to the previous step<1>.
2. Remove the Front Panel ASS'Y, referring to the previous step<2>.
3. Remove 2 screws(S4) and then remove the Phone PCB(43-3).
4. Disconnect the lead wire(BN73-5P) from connector(CN73) on the PHONE PCB(43-3).

<5>Volume PCB(43-5) REMOVAL

1. Remove the Top-cabinet, referring to the previous step<1>.
2. Remove the Front Panel ASS'Y, referring to the previous step<2>.
3. Pull out the Volume Knob ASS'Y .
4. Remove 4 screws(S3) and then Volume PCB(43-5).
5. Disconnect the lead wire(BN81-5P) from connector(CN81) on the Volume PCB(43-5).

<6>POWER LED PCB(43-2) REMOVAL

1. Remove the Top-cabinet, referring to the previous step<1>.
2. Remove the Front Panel ASS'Y, referring to the previous step<2>.
3. Remove 2 screws(S3) and then remove the Power led PCB(43-2).
4. Disconnect the lead wire(BN82-5P) from connector(CN82) on the Power led PCB(43-2).

<7> Front input video PCB(43-6) REMOVAL

1. Remove the Top-cabinet, referring to the previous step<1>.
2. Remove the Front Panel ASS'Y, referring to the previous step<2>.
3. Remove 2 screws(S3) and then remove the Front input video PCB(43-6).

<8>FRONT PCB(43-1) REMOVAL

1. Remove the Top-cabinet, referring to the previous step<1>.
2. Remove the Front Panel ASS'Y, referring to the previous step<2>.
3. Remove the Potentiometer PCB(43-4) , referring to the previous step<3>.
4. Remove the PHONE PCB(43-3), referring to the previous step<4>.
5. Remove the Volume PCB(43-5), referring to the previous step<5>.
6. Remove the POWER LED PCB(43-2), referring to the previous step<6>.
7. Remove the Front input video PCB(43-6), referring to the previous step<7>.
8. Remove 12 screws(S3) and then remove the Front PCB(43-1).

<9>TUNER MODULE(34) REMOVAL

1. Remove the Top-cabinet, referring to the previous step<1>.
2. Disconnect the connector(CON1-Card cable) from connector(CN26) on the Input PCB(45).
3. Remove 2 screws(S5) and then remove the Tuner Module(47).

<10>VIDEO PCB(43-8) REMOVAL

1. Remove the Top-cabinet, referring to the previous step<1>.
2. Disconnect the connector(CN85-Card cable) from connector(CN85) on the Input PCB(45).
3. Remove 4 screws(S8,S5) and then remove the Video PCB(43).

<11>DSP PCB(46-1) REMOVAL

1. Remove the Top-cabinet, referring to the previous step<1>.
2. Disconnect the connector(CN51,52,71-Card cable) from connector(CN51,52,71) on the Input PCB(45).
3. Disconnect the connector (CN51) from lead wire(BN51-11P) on the Tr PCB(46-2).
4. Remove 5 screws(S8,S5,S14) and then remove the DSP PCB(46-1).

<12>INPUT PCB(46-1) REMOVAL

1. Remove the Top-cabinet, referring to the previous step<1>.
2. Disconnect the connector(CN21-Card cable) from connector(CN21) on the Main PCB(44-1).
3. Disconnect the connector (CN24) from lead wire(BN24-5P) on the Main PCB(44-1).
4. Remove 7 screws(S5,S14) and then remove the DSP PCB(46-1).

<13>POWER TRANS(30) REMOVAL

1. Remove the Top-cabinet, referring to the previous step<1>.
2. Disconnect the connector (CN15,CN12) on the Trans PCB(43-7) from lead wire(BN15-3P,BN12-2P) on the Main PCB(44-1).
3. Disconnect the connector (CN11,CN14,CN15) on the Main PCB(44-1) from lead wire(BN11-3P,BN14-13P,BN15-3P) on the Trans PCB(43-7)
4. Remove 4 Trans screws(S15) and then remove the Power Trans(42).

<14>MAIN PCB ASS'Y(44) REMOVAL

1. Remove the Top-cabinet, referring to the previous step<1>.
2. Remove the Power Trans(43-7),referring to the previous step<13>.
3. Remove the TUNER MODULE(34), referring to the previous step<9>.
4. Remove the VIDEO PCB(43-8), referring to the previous step<10>.
5. Remove the DSP PCB(46-1), referring to the previous step<11>.
6. Remove the INPUT PCB(46-1), referring to the previous step<12>.

7. Disconnect the connector(CN13) from lead wire(BN13-9P) on the Front PCB(43-1).
8. Disconnect the connector(CN73) from lead wire(BN73-5P) on the PHONE PCB(43-3).
9. Disconnect the connector(CN61) from Power cord(35).
10. Remove 15 screws(S5-7EA, S8-2EA,S14-3EA,S9-1EA,S10-1EA,S3-1EA) and then remove the Main PCB ASS'Y(44).

HK3490/230 EXPLODE VIEW

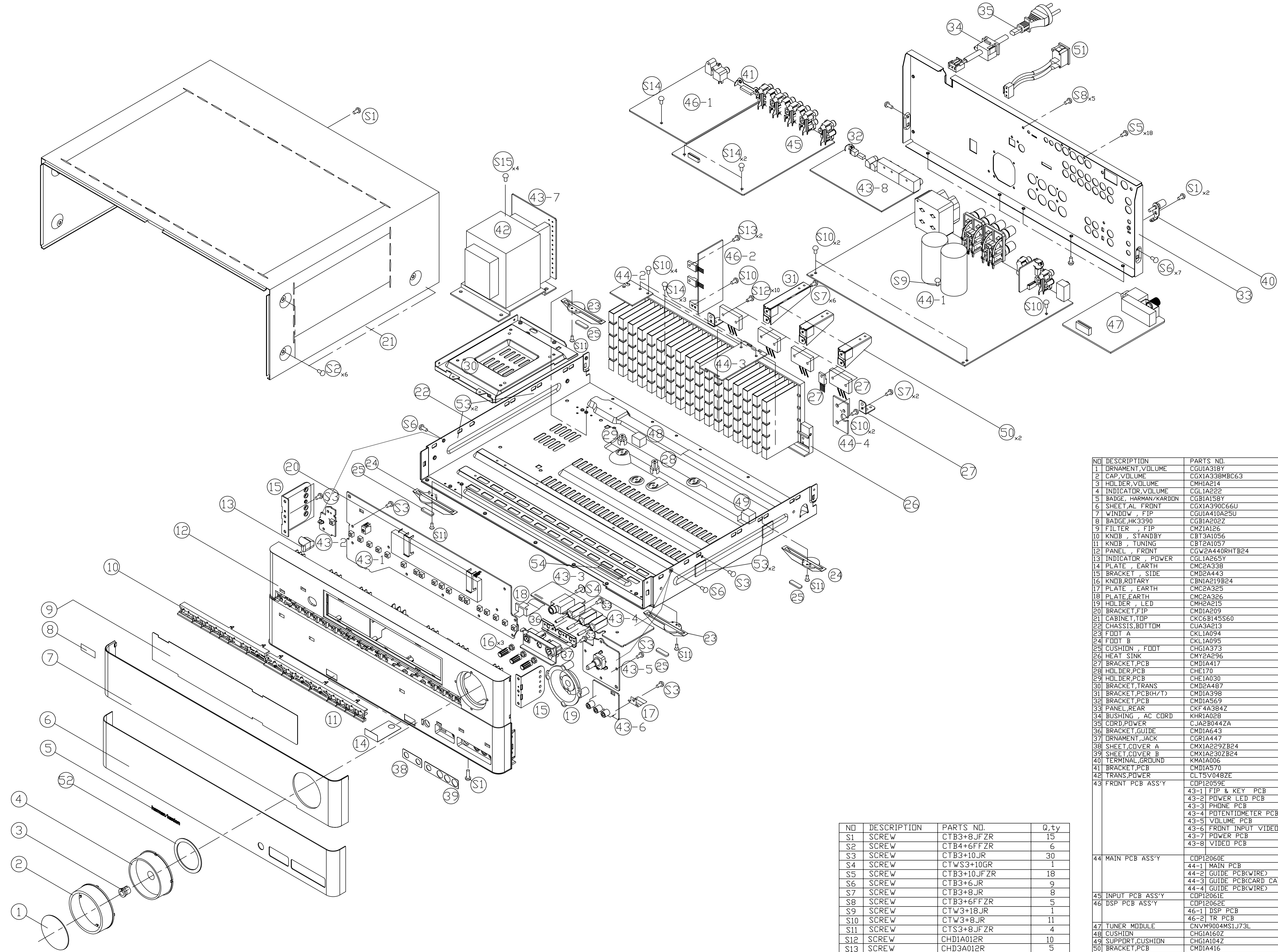

NO	DESCRIPTION	PARTS NO.	Q,ty	REMARK
1	ORNAMENT,VOLUME	CGUIA318Y	1	
2	CAP,VOLUME	CGXIA338MBC63	1	
3	HOLDER,VOLUME	CMHIA214	1	
4	INDICATOR,VOLUME	CGLIA222	1	
5	BADGE, HARMAN/KARDON	CGBIA158Y	1	
6	SHEET,AL FRONT	CGXIA390C66U	1	
7	WINDOW, FIP	CGUIA410A25U	1	
8	BADGE,HK3390	CGBIA202Z	1	
9	FILTER, FIP	CMZIA126	1	
10	KNOB, STANDBY	CBT3A1056	1	
11	KNOB, TUNING	CBT2A1057	1	
12	PANEL, FRONT	CGW2A440RHTB24	1	
13	INDICATOR, POWER	CGLIA265Y	1	
14	PLATE, EARTH	CMC2A338	2	
15	BRACKET, SIDE	CMDBA443	2	
16	KNOB,ROTARY	CBNIA219B24	3	
17	PLATE, EARTH	CMC2A325	1	
18	PLATE,EARTH	CMC2A326	1	
19	HOLDER, LED	CMHGA215	1	
20	BRACKET,FIP	CMDBA209	2	
21	CABINET,TOP	CKC6B145S60	1	
22	CHASSIS,BOTTOM	CUA3A213	1	
23	FOOT A	CKLIA094	2	
24	FOOT B	CKLIA095	2	
25	CUSHION, FOOT	CHGIA373	4	
26	HEAT SINK	CMY2A296	1	
27	BRACKET,PCB	CMDBA417	2	
28	HOLDER,PCB	CHE170	1	
29	HOLDER,PCB	CHE1A030	1	
30	BRACKET,TRANS	CMDBA487	1	
31	BRACKET,PCB(H/T)	CMDBA398	1	
32	BRACKET,PCB	CMDBA569	3	
33	PANEL,REAR	CKF4A384Z	1	
34	BUSHING, AC CORD	KHR1A02B	1	
35	CORD,POWER	CJA2B044ZA	1	
36	BRACKET,GUIDE	CMDBA643	1	
37	ORNAMENT,JACK	CGRIA447	1	
38	SHEET,COVER A	CMXIA229ZB24	1	
39	SHEET,COVER B	CMXIA230ZB24	1	
40	TERMINAL,GROUND	KMAIA006	1	
41	BRACKET,PCB	CMDBA570	1	
42	TRANS,POWER	CLTSY048ZE	1	
43	FRONT PCB ASS'Y	CDPI2059E	1	
		43-1 FIP & KEY PCB	1	
		43-2 POWER LED PCB	1	
		43-3 PHONE PCB	1	
		43-4 POTENTIOMETER PCB	1	
		43-5 VOLUME PCB	1	
		43-6 FRONT INPUT VIDE0 PCB	1	
		43-7 POWER PCB	1	
		43-8 VIDE0 PCB	1	
44	MAIN PCB ASS'Y	CDPI2060E	1	
		44-1 MAIN PCB	1	
		44-2 GUIDE PCB(WIRE)	1	
		44-3 GUIDE PCB(CARD CABLE)	1	
		44-4 GUIDE PCB(WIRE)	1	
45	INPUT PCB ASS'Y	CDPI2061E	1	
46	DSP PCB ASS'Y	CDPI2062E	1	
		46-1 DSP PCB	1	
		46-2 TR PCB	1	
47	TUNER MODULE	CNVN9004MSIJ73L	1	
48	CUSHION	CHGIA160Z	1	
49	SUPPORT,CUSHION	CHGIA194Z	1	
50	BRACKET,PCB	CMDBA416	2	
51	MOMS SW ASS'Y	CCHAVR155ZA	1	
52	VOLUME SHEET	CMZIA090	1	
53	CUSHION	CHGIA354	4	
54	CUSHION	CHGIA333	1	

NO	DESCRIPTION	PARTS NO.	Q,ty
S1	SCREW	CTB3+8JFZR	15
S2	SCREW	CTB4+6FFZR	6
S3	SCREW	CTB3+10JR	30
S4	SCREW	CTWS3+10GR	1
S5	SCREW	CTB3+10JFZR	18
S6	SCREW	CTB3+6JR	9
S7	SCREW	CTB3+8JR	8
S8	SCREW	CTB3+6FFZR	5
S9	SCREW	CTW3+18JR	1
S10	SCREW	CTW3+8JR	11
S11	SCREW	CTS3+8JFZR	4
S12	SCREW	CHDIA012R	10
S13	SCREW	CHD3A012R	5
S14	SCREW	CHD4A012R	6
S15	SCREW,TRANS	CHDIA023R	4

HK3490/230 Electrical Parts List			
Ref#	Component	Description	Value
	CHE154	CLAMPER , ARM	
	CPG1A743N	BOX , OFFSET CARTON HK3480/230	
	CPS5A564	PAD , SNOW L	
	CPS5A565	PAD , SNOW R	
	CQXHK3490/230	INSTRUCTION MANUAL ASSY HK3490/230	
	CARTHK3490/230	REMOCON TRANSMITTER ASS'Y	
	CGRHK3390/230ZA	COVER ASSY	
	CGR1A445	COVER A HK3390	
	CGR1A446	COVER B HK3390	
	CGX1A391C66	ORNAMENT , AL A AVR350	
	CGX1A392C66	ORNAMENT , AL B AVR350	
	CQE1A393Z	SHEET , FRONT COVER	
	CQX1A1329Z	MANUAL , INSTRUCTION HK3390/230	
	CGB1A158Y	BADGE , FRONT HARMAN/KARDON	
	CGB1A202Z	BADGE , HK3490	
	CGL1A222	INDICATOR , VOLUME	AVR130/230/330
	CGU1A318Y	ORNAMENT , VOLUME AVR255	
	CGU1A410A25Q	WINDOW , FIP	
	CGWHK3490/230	FRONT PANEL ASSY	
	CBN1A219B24	ROTARY KNOB	
	CBT2A1057	KNOB , TUNING AVR350	
	CBT3A1056	KNOB , STANDBY AVR155	
	CGL1A265Y	INDICATOR , POWER AVR155	
	CGR1A447	ORNAMENT , JACK	
	CGW2A440RHTB24	PANEL , FRONT HK3480/230	
	CHR301	CLAMPER	
	CHS1A165	TAPE , HEMELON	
	CMC2A326	PLATE , EARTH AVR350	
	CMC2A338	PLATE , EARTH AVR350	
	CMD1A643	BRACKET , GUIDE HK3390	
	CMD2A443	BRACKET , SIDE	
	CMH2A215	HOLDER , LED AVR350	
	CMX1A229ZB24	SHEET , COVER A HK3390	
	CMX1A230ZB24	SHEET , COVER B HK3390	
	CMZ1A090	SHEET , VOLUME	AVR130/230/330
	CSHAVR155ZA	MOMS SW ASS'Y	
	CSH1A009ZV	SWITCH , MOMS	
	CWZAVR255ZA	WIRE , ASS'Y(2P,150mm)	
	CTB3+10JFZR	SCREW	
	CTB3+6FFZR	SCREW	
	CTB3+6JR	SCREW	
	CTB3+8JFZR	SCREW	
	CTB3+8JR	SCREW	
	CTS3+8JFZR	SCREW	
	CTW3+18JR	SCREW	
	CTW3+8JR	SCREW	
	CUA3A213	BOTTOM CHASSIS	
	C8AGB288	BOND (MAX)	
	KHR1A028	BUSHING , AC CORD	
	KMA1A006	TERMINAL , GROUND	
CB21	CWC4C4A17B120B	CABLE , CARD	
CB26	CWC4C4A13B120B	CABLE , CARD	
CB51	CWC4F4A21A060B	CABLE , CARD	21P, 60MM
CB52	CWC4F4A19A060B	CABLE , CARD	19P, 60MM
CB85	CWC4F4A17A180B	CABLE , CARD(17P, 180mm)	
F101	KBA2C6300TLEY	FUSE	
F603	KBA2C8000TLEY	LITTEL FUSE	
F604	KBA2C8000TLEY	LITTEL FUSE	
T601	CLT5V048ZE	TRANS , MAIN POWER	
	CHD1A012ZR	SCREW , SPECIAL	
	CHD1A023R	SCREW , SPECIAL	
	CHD4A012R	SCREW , SPECIAL	
	CHE170	HOLDER , PCB	
	CHG1A104Z	CUSHUON , RUBBER	
	CHG1A160Z	CUSHION , RUBBER	

Ref#	Component	Description	Value
	CHG1A333	CUSHION , TRANS	
	CHG1A354	CUSHION, SUPPORT	
	CHG1A373	CUSHION , FOOT AVR350	
	CJA2B044ZA	CORD , POWER	EUR 16A 250V
	CJT1A020	PIN , SHORT	
	CKF4A384Z	PANEL , REAR HK3490/230	
	CKL1A094	FOOT , A AVR350	
	CKL1A095	FOOT , B AVR350	
	CLZ9W003Z	FERRITE , RING	29X7.7X19
	CLZ9Z028Z	FERRITE CORE(21.2X6.4X12.7)	K5C T
	CMD2A487	BRACKET , TRANS	
	CUAHK3490/230	BOTTOM CHASSIS ASSY	
	CNVM9004MS1J73L	TUNER , EUR MODULE	
Front PCB Ass'y			
Ref#	Component	Description	Value
	COP12059E	HK3490/230 FRONT PCB ASS'Y	
C802	CCBS1H102KBT	CAP , CERAMIC(1000PF/50V)	CH UP025 B102K-A-B Z
C803	CCBS1H102KBT	CAP , CERAMIC(1000PF/50V)	CH UP025 B102K-A-B Z
C804	CCBS1H102KBT	CAP , CERAMIC(1000PF/50V)	CH UP025 B102K-A-B Z
C806	CCEA1AH471T	CAP , ELECT	470UF 10V
C807	CCBS1H104ZFT	CAP , CERAMIC	0.1UF 50V Z
C808	CCBS1H104ZFT	CAP , CERAMIC	0.1UF 50V Z
C809	CCBS1H223ZFT	CAP , CERAMIC(22000PF/50V)	CH UP025 F223Z-A-B J
C810	CCBS1C222MXT	CAP , CERAMIC(2200PF/16V)	CH EP025 B222M-A-B J
C811	CCBS1H102KBT	CAP , CERAMIC(1000PF/50V)	CH UP025 B102K-A-B Z
C812	CCBS1H104ZFT	CAP , CERAMIC	0.1UF 50V Z
C814	CCEA1AH331T	CAP , ELECT	330UF 10V
C815	CCBS1H223ZFT	CAP , CERAMIC(22000PF/50V)	CH UP025 F223Z-A-B J
C817	CCBS1H473ZFT	CAP , CERAMIC(47000PF/50V)	CH UP025 F473Z-A-B J
C818	CCEA1CKS100T	CAP , ELECT	10UF 16V
C819	CCBS1H102KBT	CAP , CERAMIC(1000PF/50V)	CH UP025 B102K-A-B Z
C850	CCEA1CH101T	CAP , ELECT	100UF 16V
C851	CCEA1CH101T	CAP , ELECT	100UF 16V
C866	CCEA1HH220T	CAP , ELECT	22UF 50V
C868	CCKT1H101KB	CAP , CERAMIC	100PF 50V K
C869	CCKT1H101KB	CAP , CERAMIC	100PF 50V K
C870	CCKT1H101KB	CAP , CERAMIC	100PF 50V K
C871	CCKT1H101KB	CAP , CERAMIC	100PF 50V K
C872	CCKT1H101KB	CAP , CERAMIC	100PF 50V K
C873	CCEA1HH100T	CAP , ELECT	10UF 50V
C874	CCEA1HH100T	CAP , ELECT	10UF 50V
C875	CCEA1HH100T	CAP , ELECT	10UF 50V
C876	CCEA1CH101T	CAP , ELECT	100UF 16V
C877	CCEA1CH101T	CAP , ELECT	100UF 16V
C878	CCFT1H473ZF	CAP , CERAMIC	0.047UF 50V Z
C879	CCFT1H473ZF	CAP , CERAMIC	0.047UF 50V Z
C880	CCBS1H101KBT	CAP , CERAMIC(100PF/50V)	CH UP025 B101K-A-B Z
C881	CCBS1H101KBT	CAP , CERAMIC(100PF/50V)	CH UP025 B101K-A-B Z
C882	CCBS1H104ZFT	CAP , CERAMIC	0.1UF 50V Z
C883	CCBS1H104ZFT	CAP , CERAMIC	0.1UF 50V Z
C900	CCEA1HH100T	CAP , ELECT	10UF 50V
C901	CCKT1H101KB	CAP , CERAMIC	100PF 50V K
C902	CCEA1HH100T	CAP , ELECT	10UF 50V
C903	CCEA1HH100T	CAP , ELECT	10UF 50V
C904	CCCT1H470JC	CAP , CERAMIC	47PF 50V J
C905	CCEA1HH470T	CAP , ELECT	47UF 50V
C906	HCQI1H183JZT	CAP , MYLAR	0.018UF 50V J
C907	HCQI1H183JZT	CAP , MYLAR	0.018UF 50V J
C908	HCQI1H332JZT	CAP , MYLAR	3300PF 50V J
C909	CCEA1HH100T	CAP , ELECT	10UF 50V
C910	CCKT1H101KB	CAP , CERAMIC	100PF 50V K
C911	CCEA1HH470T	CAP , ELECT	47UF 50V
C912	CCCT1H470JC	CAP , CERAMIC	47PF 50V J
C913	CCEA1HH100T	CAP , ELECT	10UF 50V
C914	CCEA1HH100T	CAP , ELECT	10UF 50V

Front PCB Ass'y			
Ref#	Component	Description	Value
C915	HCQ1H823JZT	CAP , MYLAR	0.082UF 50V J
C916	HCQ1H823JZT	CAP , MYLAR	0.082UF 50V J
C917	HCQ1H183JZT	CAP , MYLAR	0.018UF 50V J
C918	HCQ1H183JZT	CAP , MYLAR	0.018UF 50V J
C919	HCQ1H332JZT	CAP , MYLAR	3300PF 50V J
C938	CCBS1E103ZFT	CAP , CERAMIC(10000PF/25V)	CH TP025 F103Z-A-B J
C949	CCBS1H104ZFT	CAP , CERAMIC	0.1UF 50V Z
C950	CCBS1H223ZFT	CAP , CERAMIC(22000PF/50V)	CH UP025 F223Z-A-B J
C951	CCBS1H223ZFT	CAP , CERAMIC(22000PF/50V)	CH UP025 F223Z-A-B J
C952	CCBS1H101KBT	CAP , CERAMIC(100PF/50V)	CH UP025 B101K-A-B Z
C953	CCBS1H101KBT	CAP , CERAMIC(100PF/50V)	CH UP025 B101K-A-B Z
C954	CCEA1HH100T	CAP , ELECT	10UF 50V
C955	CCBS1H101KBT	CAP , CERAMIC(100PF/50V)	CH UP025 B101K-A-B Z
C963	CCBS1H104ZFT	CAP , CERAMIC	0.1UF 50V Z
C967	CCBS1H104ZFT	CAP , CERAMIC	0.1UF 50V Z
C968	CCBS1H104ZFT	CAP , CERAMIC	0.1UF 50V Z
C990	HCQ1H473JZT	CAP , MYLAR	0.047UF 50V J
C991	HCQ1H473JZT	CAP , MYLAR	0.047UF 50V J
C992	HCQ1H473JZT	CAP , MYLAR	0.047UF 50V J
C993	HCQ1H473JZT	CAP , MYLAR	0.047UF 50V J
C994	HCQ1H473JZT	CAP , MYLAR	0.047UF 50V J
C995	HCQ1H473JZT	CAP , MYLAR	0.047UF 50V J
C996	HCQ1H473JZT	CAP , MYLAR	0.047UF 50V J
C997	HCQ1H473JZT	CAP , MYLAR	0.047UF 50V J
C998	HCQ1H473JZT	CAP , MYLAR	0.047UF 50V J
C999	HCQ1H473JZT	CAP , MYLAR	0.047UF 50V J
D854	CVDZJ8.2BT	DIODE , ZENER	ZJ8.2B 1/2W
D855	CVDZJ8.2BT	DIODE , ZENER	ZJ8.2B 1/2W
F603	KJCF5S	HOLDER , FUSE	
F604	KJCF5S	HOLDER , FUSE	
IC82	CVIKIA79S06PAT	I.C , REGULATOR(TO-92)	
IC83	CVIKIA78S06PAT	I.C , REGULATOR(TO-92)	
Q801	HVTKTC3203YT	T.R	KTC3203Y
Q802	HVTKRA107MT	T.R	KRA107M
Q803	HVTKRC107MT	T.R	KRC107M
Q804	HVTKRC107MT	T.R	KRC107M
Q805	HVTKRA107MT	T.R	KRA107M
Q901	HVTKRA107MT	T.R	KRA107M
R801	CRD20TF1001T	RES , CARBON	1K /1/5W /F
R802	CRD20TF1501T	RES , CARBON	1.5K /1/5W /F
R803	CRD20TF1801T	RES , CARBON	1.8K /1/5W /F
R804	CRD20TF2701T	RES , CARBON	2.7K /1/5W/F
R805	CRD20TF3301T	RES , CARBON	3.3K /1/5W/F
R806	CRD20TF5601T	RES , CARBON(5.6K/F)	
R807	CRD20TF1001T	RES , CARBON	1K /1/5W /F
R808	CRD20TF1501T	RES , CARBON	1.5K /1/5W /F
R809	CRD20TF1801T	RES , CARBON	1.8K /1/5W /F
R810	CRD20TF2701T	RES , CARBON	2.7K /1/5W/F
R811	CRD20TF3301T	RES , CARBON	3.3K /1/5W/F
R812	CRD20TF5601T	RES , CARBON(5.6K/F)	
R813	CRD20TF7501T	RES , CARBON (7.5K/F)	
R814	CRD20TF1001T	RES , CARBON	1K /1/5W /F
R815	CRD20TF1501T	RES , CARBON	1.5K /1/5W /F
R816	CRD20TF1801T	RES , CARBON	1.8K /1/5W /F
R817	CRD20TF2701T	RES , CARBON	2.7K /1/5W/F
R820	CRD20TJ102T	RES , CARBON	1K OHM 1/5W J
R826	CRD20TJ100T	RES , CARBON	10 OHM 1/5W J
R827	CRD20TJ100T	RES , CARBON	10 OHM 1/5W J
R828	CRD20TJ100T	RES , CARBON	10 OHM 1/5W J
R829	CRD20TJ123T	RES , CARBON	12K OHM 1/5W J
R830	CRD20TJ100T	RES , CARBON	10 OHM 1/5W J
R831	CRD20TJ100T	RES , CARBON	10 OHM 1/5W J
R832	CCBS1H104ZFT	CAP , CERAMIC	0.1UF 50V Z
R834	CCBS1H104ZFT	CAP , CERAMIC	0.1UF 50V Z
R835	CRD20TJ100T	RES , CARBON	10 OHM 1/5W J

Front PCB Ass'y			
Ref#	Component	Description	Value
R837	CRD20TJ102T	RES , CARBON	1K OHM 1/5W J
R838	CRD20TJ221T	RES , CARBON	220 OHM 1/5W J
R839	CRD20TJ681T	RES , CARBON	680 OHM 1/5W J
R840	CRD20TJ473T	RES , CARBON	47K OHM 1/5W J
R841	CRD20TJ561T	RES , CARBON	560 OHM 1/5W J
R842	CRD20TJ103T	RES , CARBON	10K OHM 1/5W J
R843	CRD20TJ222T	RES , CARBON	2.2K OHM 1/5W J
R852	CRD20TJ102T	RES , CARBON	1K OHM 1/5W J
R853	CRD20TJ102T	RES , CARBON	1K OHM 1/5W J
R854	CRD20TJ102T	RES , CARBON	1K OHM 1/5W J
R855	CRD20TJ332T	RES , CARBON	3.3K OHM 1/5W J
R856	CRD20TJ101T	RES , CARBON	100 OHM 1/5W J
R857	CRD20TJ392T	RES , CARBON	3.9K OHM 1/5W J
R858	CRD20TJ473T	RES , CARBON	47K OHM 1/5W J
R859	CRD20TJ470T	RES , CARBON	47 OHM 1/5W J
R860	CRD20TJ271T	RES , CARBON	270 OHM 1/5W J
R861	CRD20TJ332T	RES , CARBON	3.3K OHM 1/5W J
R862	CRD20TJ750T	RES , CARBON	75 OHM 1/5W J
R863	CRD20TJ750T	RES , CARBON	75 OHM 1/5W J
R864	CRD20TJ750T	RES , CARBON	75 OHM 1/5W J
R865	CRD20TJ332T	RES , CARBON	3.3K OHM 1/5W J
R866	CRD20TJ750T	RES , CARBON	75 OHM 1/5W J
R867	CRD20TJ750T	RES , CARBON	75 OHM 1/5W J
R868	CRD20TJ102T	RES , CARBON	1K OHM 1/5W J
R900	CRD20TJ101T	RES , CARBON	100 OHM 1/5W J
R901	CRD20TJ104T	RES , CARBON	100K OHM 1/5W J
R902	CRD20TJ104T	RES , CARBON	100K OHM 1/5W J
R903	CRD20TJ105T	RES , CARBON	1M OHM 1/5W J
R904	CRD20TJ223T	RES , CARBON	22K OHM 1/5W J
R905	CRD20TJ223T	RES , CARBON	22K OHM 1/5W J
R906	CRD20TJ222T	RES , CARBON	2.2K OHM 1/5W J
R907	CRD20TJ104T	RES , CARBON	100K OHM 1/5W J
R908	CRD20TJ331T	RES , CARBON	330 OHM 1/5W J
R909	CRD20TJ101T	RES , CARBON	100 OHM 1/5W J
R910	CRD20TJ104T	RES , CARBON	100K OHM 1/5W J
R911	CRD20TJ105T	RES , CARBON	1M OHM 1/5W J
R912	CRD20TJ104T	RES , CARBON	100K OHM 1/5W J
R913	CRD20TJ104T	RES , CARBON	100K OHM 1/5W J
R914	CRD20TJ392T	RES , CARBON	3.9K OHM 1/5W J
R915	CRD20TJ392T	RES , CARBON	3.9K OHM 1/5W J
R916	CRD20TJ681T	RES , CARBON	680 OHM 1/5W J
R917	CRD20TJ681T	RES , CARBON	680 OHM 1/5W J
R918	CRD20TJ222T	RES , CARBON	2.2K OHM 1/5W J
R919	CRD20TJ331T	RES , CARBON	330 OHM 1/5W J
R953	CRD20TJ101T	RES , CARBON	100 OHM 1/5W J
R954	CRD20TJ272T	RES , CARBON	2.7K OHM 1/5W J
R955	CRD20TJ272T	RES , CARBON	2.7K OHM 1/5W J
R956	CRD20TJ471T	RES , CARBON	470 OHM 1/5W J
R957	CRD20TJ471T	RES , CARBON	470 OHM 1/5W J
R958	CRD20TJ750T	RES , CARBON	75 OHM 1/5W J
R959	CRD20TJ474T	RES , CARBON	
R960	CRD20TJ474T	RES , CARBON	
SW801	HST1A020ZT	SW , TACT	
SW802	HST1A020ZT	SW , TACT	
SW803	HST1A020ZT	SW , TACT	
SW804	HST1A020ZT	SW , TACT	
SW805	HST1A020ZT	SW , TACT	
SW806	HST1A020ZT	SW , TACT	
SW807	HST1A020ZT	SW , TACT	
SW808	HST1A020ZT	SW , TACT	
SW809	HST1A020ZT	SW , TACT	
SW810	HST1A020ZT	SW , TACT	
SW811	HST1A020ZT	SW , TACT	
SW812	HST1A020ZT	SW , TACT	
SW813	HST1A020ZT	SW , TACT	

Front PCB Ass'y			
Ref#	Component	Description	Value
SW814	HST1A020ZT	SW , TACT	
SW815	HST1A020ZT	SW , TACT	
SW816	HST1A020ZT	SW , TACT	
SW817	HST1A020ZT	SW , TACT	
SW818	HST1A020ZT	SW , TACT	
SW819	HST1A020ZT	SW , TACT	
SW838	HST1A020ZT	SW , TACT	
BK81	CMD1A569	BRACKET , PCB	
BK91	CMD1A209	BRACKET , FLT	A4-92-1739
BK92	CMD1A209	BRACKET , FLT	A4-92-1739
BK99	CMC2A325	PLATE , EARTH AVR155	
BN11	CWB1C903150EN	WIRE ASS'Y (150MM)	DV7500
BN13	CWB2B909350EN	WIRE ASS'Y	
BN14	CWB1C913300EN	WIRE ASS'Y (13P, 300mm)	
BN16	CWB3F903350UZ	WIRE ASS'Y (3P, 350mm)	
BN22	CWZHK3490BN22	SHIELD WIRE ASS'Y	11P, 300MM, 2MM PITCH
BN81	CWB2B905080EN	WIRE ASS'Y	
BN82	CWB2B905080EN	WIRE ASS'Y	
BN84	CWZHK3390BN84	SHIELD WIRE ASS'Y	
BN85	CJP17GA117ZY	WAFER	
CN12	CJP02KA060ZY	WAFER	
CN15	CJP03GA90ZY	WAFER	
CN33	CJP05GA19ZY	WAFER , STRAIGHT	
CN81	CJP05GA19ZY	WAFER , STRAIGHT	
CN82	CJP05GA19ZY	WAFER , STRAIGHT	
CN83	CJP07GB113ZY	WAFER , CARD CABLE	
CN87	CJP19GA115ZY	WAFER	
D801	HVD1N5819T	DIODE , SCHOTTKY	1N5819
D802	CVD1L0345W31BOCT20	L.E.D , WHITE	CVD1L0345W31BOCT201
D803	CVD30ASOGCAA-S7	L.E.D , ORANGE	T0L-30ASOGCAA-S7
D804	CVD1L0345W31BOCT20	L.E.D , WHITE	CVD1L0345W31BOCT201
D805	CVD1L0345W31BOCT20	L.E.D , WHITE	CVD1L0345W31BOCT201
D806	CVD1L0345W31BOCT20	L.E.D , WHITE	CVD1L0345W31BOCT201
FL1	CFL17BT031GINK	F.I.P , AVR355	17-BT-31GINK
IC81	HVINJM2296M	I.C , VIDEO SW	NJM2296M
IC84	BVIKP1010B	IC, PHOTO COUPLER	
IC91	HVINJM2068MDTE1	I.C , OP AMP	NJM2068MD-TE1
JK81	CJJ4S028Y	JACK , BOARD (3P SILVER)	
JK83	CJJ2E026Z	JACK , HEADPHONE(SILVER PLATE)	
JK85	CJJ4N043Z	JACK , BOARD	
JK86	CJJ4S010Z	JACK , BOARD	
JK87	CJJ2D008Z	JACK , STEREO	
JK88	CJJ2D008Z	JACK , STEREO	
JW90	CWE8202120RV	WIRE ASS'Y	
JW96	CWE8202120RV	WIRE ASS'Y	
JW97	CWE8202120RV	WIRE ASS'Y	
JW98	CWE8202120RV	WIRE ASS'Y	
JW99	CWE8202080RV	WIRE ASS'Y(1P)	
RC81	HRVNJL34H380A	SENSOR , REMOCON	
R951	CRQ1AJR47H	RES , FUSE	
R952	CRQ1AJR47H	RES , FUSE	
R998	CRQ1AJR47H	RES , FUSE	
R999	CRQ1AJR47H	RES , FUSE	
SW820	CST1A010Z	SW , TACT	
VR90	CVV2K21M104Z	RES , VARIABLE(100K, MN CURVE, PUSH LOCK)	
VR91	CVV2K20C104Z	RES , VARIABLE(100K, C CURVE, PUSH LOCK)	
VR92	CVV2K20C104Z	RES , VARIABLE(100K, C CURVE, PUSH LOCK)	
VR95	CSR2A037Z	ENCODER	
	CPE1A009	SHEET , BLIND	
	CTB3+10JR	SCREW	
	CTWS3+10GR	SCREW	
CB87	CWC4C4A19B220B	CABLE , CARD(19P, 220MM,1.25MM)	
	CGX1A338MBC63	CAP , VOLUME	
	CGX1A390C66U	SHEET , AL FRONT HK3490/230	
	CKC6B145S60	CABINET , TOP AVR350	

Front PCB Ass'y			
Ref#	Component	Description	Value
	CMH1A214	HOLDER , VOLUME	AVR130/230/330
	CMZ1A127	FILTER , FIP AVR255	
	CQB1A549Y	LABEL , ATTENTION DVD48	
	CQB1A551Z	LABEL , BAR CODE	
	CQB1A622	LABEL , SERIAL NO	
	CTB3+6FFZR	SCREW	
	CTB3+8JFZR	SCREW	
	CTB4+6FFZR	SCREW	
Main PCB Ass'y			
Ref#	Component	Description	Value
	COP12060E	HK3490/230 MAIN PCB ASS'Y	
	CHD3A012R	SCREW , SPECIAL	
C102	CCBS1E103ZFT	CAP , CERAMIC(10000PF/25V)	CH TP025 F103Z-A-B J
C103	CCEA1JH470TS	CAP , ELECT	63V/47UF/105°C
C104	CCEA1JH470TS	CAP , ELECT	63V/47UF/105°C
C105	CCBS1E103ZFT	CAP , CERAMIC(10000PF/25V)	CH TP025 F103Z-A-B J
C107	CCEA1EH101T	CAP , ELECT	100UF 25V
C110	CCBS1H223ZFT	CAP , CERAMIC(22000PF/50V)	CH UP025 F223Z-A-B J
C111	CCEA1CH101T	CAP , ELECT	100UF 16V
C113	CCBS1H223ZFT	CAP , CERAMIC(22000PF/50V)	CH UP025 F223Z-A-B J
C114	CCBS1H223ZFT	CAP , CERAMIC(22000PF/50V)	CH UP025 F223Z-A-B J
C117	CCBS1H473ZFT	CAP , CERAMIC(47000PF/50V)	CH UP025 F473Z-A-B J
C118	CCBS1H473ZFT	CAP , CERAMIC(47000PF/50V)	CH UP025 F473Z-A-B J
C119	CCEA1EH101T	CAP , ELECT	100UF 25V
C120	CCEA1EH101T	CAP , ELECT	100UF 25V
C132	CCEA1HHR47T	CAP , ELECT	0.47UF 50V
C133	CCEA1HH220T	CAP , ELECT	22UF 50V
C134	CCBS1H104ZFT	CAP , CERAMIC	0.1UF 50V Z
C201	CCBS1H101KBT	CAP , CERAMIC(100PF/50V)	CH UP025 B101K-A-B Z
C202	CCBS1H101KBT	CAP , CERAMIC(100PF/50V)	CH UP025 B101K-A-B Z
C203	CCBS1H101KBT	CAP , CERAMIC(100PF/50V)	CH UP025 B101K-A-B Z
C204	CCBS1H101KBT	CAP , CERAMIC(100PF/50V)	CH UP025 B101K-A-B Z
C240	CCEA1HH1R0T	CAP , ELECT	1UF 50V
C241	CCEA1HH0R1T	CAP , ELECT	0.1UF 50V
C301	CCEA1HH100T	CAP , ELECT	10UF 50V
C302	CCEA1HH100T	CAP , ELECT	10UF 50V
C303	CCKT1H471KB	CAP , CERAMIC	470PF 50V K
C304	CCKT1H471KB	CAP , CERAMIC	470PF 50V K
C305	CCEA1CH101T	CAP , ELECT	100UF 16V
C306	CCEA1CH101T	CAP , ELECT	100UF 16V
C311	CCCT1H120JC	CAP , CERAMIC	12PF 50V J
C312	CCCT1H120JC	CAP , CERAMIC	12PF 50V J
C313	CCCT1H330JC	CAP , CERAMIC	33PF 50V J
C314	CCCT1H330JC	CAP , CERAMIC	33PF 50V J
C315	CCEA1HH100T	CAP , ELECT	10UF 50V
C316	CCEA1HH100T	CAP , ELECT	10UF 50V
C317	CCEA1HH100T	CAP , ELECT	10UF 50V
C318	CCEA1HH100T	CAP , ELECT	10UF 50V
C319	HCQ11H473JZT	CAP , MYLAR	0.047UF 50V J
C320	HCQ11H473JZT	CAP , MYLAR	0.047UF 50V J
C321	CCBS1H473ZFT	CAP , CERAMIC(47000PF/50V)	CH UP025 F473Z-A-B J
C331	HCQ11H562JZT	CAP , MYLAR	5600PF 50V J
C332	HCQ11H562JZT	CAP , MYLAR	5600PF 50V J
C333	HCQ11H562JZT	CAP , MYLAR	5600PF 50V J
C334	HCQ11H562JZT	CAP , MYLAR	5600PF 50V J
C335	HCQ11H473JZT	CAP , MYLAR	0.047UF 50V J
C336	HCQ11H473JZT	CAP , MYLAR	0.047UF 50V J
C341	CCEA1HH4R7T	CAP , ELECT	4.7UF 50V
C342	CCBS1H223ZFT	CAP , CERAMIC(22000PF/50V)	CH UP025 F223Z-A-B J
C343	CCEA1AH471T	CAP , ELECT	470UF 10V
C351	CCKT1H101KB	CAP , CERAMIC	100PF 50V K
C352	CCKT1H101KB	CAP , CERAMIC	100PF 50V K
D102	CVDZJ33BT	DIODE , ZENER	
D103	CVDZJ6.8BT	DIODE , ZENER	ZJ6.8B 1/2W

Main PCB Ass'y			
Ref#	Component	Description	Value
D104	CVD1N4003ST	DIODE , RECT	1N4003
D105	CVD1SS133MT	DIODE	1SS133
D106	CVD1SS133MT	DIODE	1SS133
D107	CVD1SS133MT	DIODE	1SS133
D108	CVD1SS133MT	DIODE	1SS133
D109	CVD1N4003ST	DIODE , RECT	1N4003
D110	CVD1N4003ST	DIODE , RECT	1N4003
D111	CVD1N4003ST	DIODE , RECT	1N4003
D112	CVD1N4003ST	DIODE , RECT	1N4003
D114	CVD1N4003ST	DIODE , RECT	1N4003
D115	CVD1N4003ST	DIODE , RECT	1N4003
D116	CVD1N4003ST	DIODE , RECT	1N4003
D117	CVD1N4003ST	DIODE , RECT	1N4003
D118	CVDZJ27BT	DIODE , ZENER	ZJ27B 1/2W
D119	CVDZJ27BT	DIODE , ZENER	ZJ27B 1/2W
D124	CVD1N4003SRT	DIODE , RECT	1N4003
D125	CVD1N4003SRT	DIODE , RECT	1N4003
D126	CVDZJ6.2BT	DIODE , ZENER	ZJ6.2B 1/2W
D127	CVD1SS133MT	DIODE	1SS133
D132	CVD1N4003SRT	DIODE , RECT	1N4003
D133	CVD1N4003SRT	DIODE , RECT	1N4003
D201	CVD1SS133MT	DIODE	1SS133
D202	CVD1SS133MT	DIODE	1SS133
D203	CVD1SS133MT	DIODE	1SS133
D204	CVD1SS133MT	DIODE	1SS133
D301	CVD1SS133MT	DIODE	1SS133
D302	CVD1SS133MT	DIODE	1SS133
D303	CVD1SS133MT	DIODE	1SS133
D304	CVD1SS133MT	DIODE	1SS133
D305	CVD1SS133MT	DIODE	1SS133
D306	CVD1SS133MT	DIODE	1SS133
D307	CVD1SS133MT	DIODE	1SS133
D308	CVD1SS133MT	DIODE	1SS133
D309	CVD1SS133MT	DIODE	1SS133
D310	CVD1SS133MT	DIODE	1SS133
ET11	HJT1A025	PALTE , EARTH	MET37-0002
F101	KJCF5S	HOLDER , FUSE	
F102	KBA2D2500TLET	FUSE	
Q101	HVTKSC2316YT	T.R	KSC2316Y
Q102	HVTKRC107MT	T.R	KRC107M
Q103	HVTKRC107MT	T.R	KRC107M
Q104	HVTKSC2785YT	T.R	KSC2785Y
Q207	HVTKTC2874BT	T.R , MUTE	KTC2874B
Q208	HVTKTC2874BT	T.R , MUTE	KTC2874B
Q209	HVTKRA107MT	T.R	KRA107M
Q210	HVTKRC107MT	T.R	KRC107M
Q301	HVTKTC3200GRT	T.R	KTC3200GR
Q302	HVTKTC3200GRT	T.R	KTC3200GR
Q303	HVTKTC3200GRT	T.R	KTC3200GR
Q304	HVTKTC3200GRT	T.R	KTC3200GR
Q305	HVTKTC3200GRT	T.R	KTC3200GR
Q306	HVTKTC3200GRT	T.R	KTC3200GR
Q307	HVTKTA1268GRT	T.R	KTA1268GR
Q308	HVTKTA1268GRT	T.R	KTA1268GR
Q309	HVTKTA1268GRT	T.R	KTA1268GR
Q310	HVTKTA1268GRT	T.R	KTA1268GR
Q311	HVTKTC3200GRT	T.R	KTC3200GR
Q312	HVTKTC3200GRT	T.R	KTC3200GR
Q323	HVTKSC2785YT	T.R	KSC2785Y
Q324	HVTKSC2785YT	T.R	KSC2785Y
Q331	HVTKSA1175YT	T.R	KSA1175Y(DEAD)
Q332	HVTKRA107MT	T.R	KRA107M
Q333	HVTKSC2785YT	T.R	KSC2785Y
Q334	HVTKSC2785YT	T.R	KSC2785Y
Q335	HVTKRC107MT	T.R	KRC107M

Main PCB Ass'y			
Ref#	Component	Description	Value
Q336	HVTKRC107MT	T.R	KRC107M
Q337	HVTKRA107MT	T.R	KRA107M
Q338	HVTKRA107MT	T.R	KRA107M
Q339	HVTKRC107MT	T.R	KRC107M
Q340	HVTKRA107MT	T.R	KRA107M
Q341	HVTKRC107MT	T.R	KRC107M
Q342	HVTKRA107MT	T.R	KRA107M
Q343	HVTKRC107MT	T.R	KRC107M
Q344	HVTKRA107MT	T.R	KRA107M
Q345	HVTKRC107MT	T.R	KRC107M
R103	CRD20TJ122T	RES , CARBON	1.2K OHM 1/5W J
R104	CRD20TJ473T	RES , CARBON	47K OHM 1/5W J
R106	CRD25TJ820T	RES , CARBON	
R107	CRD20TJ222T	RES , CARBON	2.2K OHM 1/5W J
R110	CRD25TJ393T	RES , CARBON	
R111	CRD25TJ393T	RES , CARBON	
R112	CRD25TJ393T	RES , CARBON	
R113	CRD25TJ393T	RES , CARBON	
R114	CRD20TJ182T	RES , CARBON	1.8K OHM 1/5W J
R115	CRD20TJ182T	RES , CARBON	1.8K OHM 1/5W J
R116	CRD20TJ182T	RES , CARBON	1.8K OHM 1/5W J
R117	CRD20TJ182T	RES , CARBON	1.8K OHM 1/5W J
R118	CRD25TJ123T	RES , CARBON	
R119	CRD25TJ123T	RES , CARBON	
R128	CRD25TJ222T	RES , CARBON	
R129	CRD20TJ103T	RES , CARBON	10K OHM 1/5W J
R130	CRD20TJ473T	RES , CARBON	47K OHM 1/5W J
R201	CRD20TJ101T	RES , CARBON	100 OHM 1/5W J
R202	CRD20TJ101T	RES , CARBON	100 OHM 1/5W J
R203	CRD20TJ101T	RES , CARBON	100 OHM 1/5W J
R204	CRD20TJ101T	RES , CARBON	100 OHM 1/5W J
R205	CRD20TJ184T	RES , CARBON	
R206	CRD20TJ184T	RES , CARBON	
R207	CRD20TJ184T	RES , CARBON	
R208	CRD20TJ184T	RES , CARBON	
R231	CRD25TJ822T	RES , CARBON	
R232	CRD20TJ103T	RES , CARBON	10K OHM 1/5W J
R233	CRD20TJ562T	RES , CARBON	5.6K OHM 1/5W J
R234	CRD20TJ332T	RES , CARBON	3.3K OHM 1/5W J
R235	CRD20TJ332T	RES , CARBON	3.3K OHM 1/5W J
R239	CRD20TJ105T	RES , CARBON	1M OHM 1/5W J
R240	CRD20TJ100T	RES , CARBON	10 OHM 1/5W J
R241	CRD20TJ100T	RES , CARBON	10 OHM 1/5W J
R242	CRD25TJ103T	RES , CARBON	
R303	CRD20TJ333T	RES , CARBON	33K OHM 1/5W J
R304	CRD20TJ333T	RES , CARBON	33K OHM 1/5W J
R305	CRD20TJ471T	RES , CARBON	470 OHM 1/5W J
R306	CRD20TJ471T	RES , CARBON	470 OHM 1/5W J
R307	CRD20TJ100T	RES , CARBON	10 OHM 1/5W J
R308	CRD20TJ100T	RES , CARBON	10 OHM 1/5W J
R309	CRD20TJ271T	RES , CARBON	270 OHM 1/5W J
R310	CRD20TJ271T	RES , CARBON	270 OHM 1/5W J
R311	CRD20TJ121T	RES , CARBON	120 OHM 1/5W J
R312	CRD20TJ121T	RES , CARBON	120 OHM 1/5W J
R313	CRD20TJ121T	RES , CARBON	120 OHM 1/5W J
R314	CRD20TJ121T	RES , CARBON	120 OHM 1/5W J
R315	CRD20TJ152T	RES , CARBON	1.5K OHM 1/5W J
R316	CRD20TJ152T	RES , CARBON	1.5K OHM 1/5W J
R317	CRD20TJ152T	RES , CARBON	1.5K OHM 1/5W J
R318	CRD20TJ152T	RES , CARBON	1.5K OHM 1/5W J
R319	CRD20TJ333T	RES , CARBON	33K OHM 1/5W J
R320	CRD20TJ333T	RES , CARBON	33K OHM 1/5W J
R321	CRD20TJ122T	RES , CARBON	1.2K OHM 1/5W J
R322	CRD20TJ122T	RES , CARBON	1.2K OHM 1/5W J
R323	CRD20TJ561T	RES , CARBON	560 OHM 1/5W J

Main PCB Ass'y			
Ref#	Component	Description	Value
R324	CRD20TJ561T	RES , CARBON	560 OHM 1/5W J
R325	CRD20TJ561T	RES , CARBON	560 OHM 1/5W J
R326	CRD20TJ561T	RES , CARBON	560 OHM 1/5W J
R327	CRD20TJ561T	RES , CARBON	560 OHM 1/5W J
R328	CRD20TJ561T	RES , CARBON	560 OHM 1/5W J
R329	CRD20TJ561T	RES , CARBON	560 OHM 1/5W J
R330	CRD20TJ561T	RES , CARBON	560 OHM 1/5W J
R331	CRD20TJ561T	RES , CARBON	560 OHM 1/5W J
R332	CRD20TJ561T	RES , CARBON	560 OHM 1/5W J
R333	CRD20TJ561T	RES , CARBON	560 OHM 1/5W J
R334	CRD20TJ561T	RES , CARBON	560 OHM 1/5W J
R335	CRD20TJ750T	RES , CARBON	75 OHM 1/5W J
R336	CRD20TJ750T	RES , CARBON	75 OHM 1/5W J
R337	CRD20TJ750T	RES , CARBON	75 OHM 1/5W J
R338	CRD20TJ750T	RES , CARBON	75 OHM 1/5W J
R339	CRD20TJ223T	RES , CARBON	22K OHM 1/5W J
R340	CRD20TJ223T	RES , CARBON	22K OHM 1/5W J
R341	CRD20TJ223T	RES , CARBON	22K OHM 1/5W J
R342	CRD20TJ223T	RES , CARBON	22K OHM 1/5W J
R343	CRD20TJ122T	RES , CARBON	1.2K OHM 1/5W J
R344	CRD20TJ122T	RES , CARBON	1.2K OHM 1/5W J
R345	CRD20TJ331T	RES , CARBON	330 OHM 1/5W J
R346	CRD20TJ331T	RES , CARBON	330 OHM 1/5W J
R347	CRD25FJ3R3T	RES , CARBON	3.3 OHM 1/4W J
R348	CRD25FJ3R3T	RES , CARBON	3.3 OHM 1/4W J
R349	CRD25FJ3R3T	RES , CARBON	3.3 OHM 1/4W J
R350	CRD25FJ3R3T	RES , CARBON	3.3 OHM 1/4W J
R351	CRD25FJ470T	RES , CARBON	47 OHM 1/4W J
R352	CRD25FJ470T	RES , CARBON	47 OHM 1/4W J
R353	CRD25FJ470T	RES , CARBON	47 OHM 1/4W J
R354	CRD25FJ470T	RES , CARBON	47 OHM 1/4W J
R357	CRD20TJ271T	RES , CARBON	270 OHM 1/5W J
R358	CRD20TJ271T	RES , CARBON	270 OHM 1/5W J
R359	CRD20TJ102T	RES , CARBON	1K OHM 1/5W J
R360	CRD20TJ102T	RES , CARBON	1K OHM 1/5W J
R361	CRD20TJ182T	RES , CARBON	1.8K OHM 1/5W J
R362	CRD20TJ182T	RES , CARBON	1.8K OHM 1/5W J
R363	CRD20TJ102T	RES , CARBON	1K OHM 1/5W J
R364	CRD20TJ102T	RES , CARBON	1K OHM 1/5W J
R365	CRD20TJ103T	RES , CARBON	10K OHM 1/5W J
R366	CRD20TJ103T	RES , CARBON	10K OHM 1/5W J
R367	CRD25TJ223T	RES , CARBON	22K OHM 1/4W J
R368	CRD25TJ223T	RES , CARBON	22K OHM 1/4W J
R371	CRD25TJ470T	RES , CARBON	
R372	CRD25TJ470T	RES , CARBON	
R373	CRD25TJ470T	RES , CARBON	
R374	CRD25TJ470T	RES , CARBON	
R381	CRD20TJ273T	RES , CARBON	27K OHM 1/5W J
R382	CRD20TJ273T	RES , CARBON	27K OHM 1/5W J
R383	CRD20TJ473T	RES , CARBON	47K OHM 1/5W J
R384	CRD20TJ152T	RES , CARBON	1.5K OHM 1/5W J
R385	CRD20TJ473T	RES , CARBON	47K OHM 1/5W J
R386	CRD20TJ102T	RES , CARBON	1K OHM 1/5W J
R391	CRD20TJ470T	RES , CARBON	47 OHM 1/5W J
R392	CRD20TJ470T	RES , CARBON	47 OHM 1/5W J
R393	CRD20TJ470T	RES , CARBON	47 OHM 1/5W J
R394	CRD20TJ470T	RES , CARBON	47 OHM 1/5W J
R395	CRD20TJ470T	RES , CARBON	47 OHM 1/5W J
R396	CRD20TJ393T	RES , CARBON	
VR31	CVN1RA221B02T	RES , SEMI FIXED (220, B CURVE)	KVSF637AVC
VR32	CVN1RA221B02T	RES , SEMI FIXED (220, B CURVE)	KVSF637AVC
	CMYHK3490	HEAT SINK ASSY	
	CHD1A012R	SCREW , SPECIAL	
	CMD1A398	BRACKET , PCB	AG-D9320
	CMD1A416	BRACKET , PCB(H/T)	AG-D8900

Main PCB Ass'y			
Ref#	Component	Description	Value
	CMD1A417	BRACKET , PCB	AG-D8900
	CMY2A296	HEAT SINK HK3490	
	CTB3+8JR	SCREW	
Q317	HVTKTC3114A	T.R , BIAS	KTC3114A
Q318	HVTKTC3114A	T.R , BIAS	KTC3114A
Q319	HVT2SD2401P	T.R , POWER(DARINGTON)	
Q320	HVT2SD2401P	T.R , POWER(DARINGTON)	
Q321	HVT2SB1570P	T.R , POWER(DARINGTON)	
Q322	HVT2SB1570P	T.R , POWER(DARINGTON)	
BK11	CMD1A569	BRACKET , PCB	
BK12	CMD1A569	BRACKET , PCB	
BN12	CWZHK3490BN12	WIRE ASS'Y	2P, 180MM, 3.96MM PITCH
BN15	CWB3FE03350UP	WIRE ASS'Y	3P, 350MM, 3.96MM PITCH
BN23	CJP11GB99ZY	WAFER	
BN24	CWZHK3490BN24	SHIELD WIRE ASS'Y	5P, 50MM, 2MM PITCH
BN73	CWZHK3390BN73	WIRE ASS'Y (5P, 600mm)	
CN11	CJP03GA19ZY	WAFER , STRAIGHT(3PIN)	
CN13	CJP09GA19ZY	WAFER, STRAIGHT, 9PIN	
CN15	CJP02KA060ZY	WAFER	
CN16	CJP03GA90ZY	WAFER	
CN18	CJP02GA89ZY	WAFER	
CN21	CJP17GA115ZY	WAFER , CARDCABLE	
CN23	CJP11GA98ZY	WAFER	
CN31	CJP02GA01ZY	WAFER , STRAIGHT, 2PIN	
CN32	CJP02GA01ZY	WAFER , STRAIGHT, 2PIN	
C106	CCEA1JH471E	CAP , ELECT	
C108	KCKDKS472ME	CAP , CERAMIC(X1/Y2/SC)	0.0047UF/2.5KV
C109	HCQE2E104KDE	CAP , LINE ACROSS	
C112	CCEA1CH332E	CAP , ELECT	
C115	CCET63VKL5153NK	CAP , ELECT	
C116	CCET63VKL5153NK	CAP , ELECT	
C121	CCET35VKL5822NK	CAP, ELECT (35V/8200UF, 25X40)	
C122	CCET35VKL5682NK	CAP , ELECT	6800UF/35V (22X35)
C123	KCKDKS471ME	CAP , CERAMIC(KH TYPE)	DKS471ME
C307	CCEA2AH101E	CAP , ELECT	
C308	CCEA2AH101E	CAP , ELECT	
C309	CCEA2AH101E	CAP , ELECT	
C310	CCEA2AH101E	CAP , ELECT	
D113	CMY4A138ZA	HEAT SINK ASS'Y	
	CMY4A138	HEAT SINK , DIODE	H60
	CTB3+10JR	SCREW	
	HVDGBJ806MF	DIODE , BRIDGE	GBJ806MF(MIC)
IC11	HVIKIA7805API	REGULATOR, +5V	7805API (KEC)
IC12	CVIL7815CPHA	I.C REG HEAT SINK ASS'Y(CMY4A222)	
	CMY4A222	HEAT SINK	
	CTB3+8JR	SCREW	
	HVIL7815CP	I.C, REGULATOR	
IC13	CVIL7915CPVA	I.C ASS'Y	
	CMY1A043	HEAT SINK , TR	
	CTB3+8JR	SCREW	
	HVIL7915CP	I.C, REGULATOR	
IC14	HVIS-80842CNY-X	I.C , RESET	S-80842CNY-X
JK21	CJJ4P014W	JACK , IN/OUT	
JK22	CJJ4N082Z	JACK , IN/OUT(BK, BK)	RCA-207AE-06
JK23	HJJ1D002Z	JACK , STEREO(2P 3.5PIE)	SR7400
JK31	CJJ5Q018Z	TERMINAL , 8P SPEAKER(SCREW, RD/BK/BK/W)	JB-801A-23
JW12	CWE8202120RV	WIRE ASS'Y	
L301	CLEY0R5KAK	COIL , SPEAKER	0.5UH K
L302	CLEY0R5KAK	COIL , SPEAKER	0.5UH K
OL11	KJJ7A025Z	OUTLET , EUR(2P)	A3-04-D007-2P
Q313	HVTKTA1360Y	T.R , PRE DRIVE	KTA1360Y
Q314	HVTKTA1360Y	T.R , PRE DRIVE	KTA1360Y
Q315	HVTKTC3423Y	T.R , PRE DRIVE	KTC3423Y
Q316	HVTKTC3423Y	T.R , PRE DRIVE	KTC3423Y
RY11	HSL1A008ZE	RELAY	SDT-S-112DMR

Main PCB Ass'y			
Ref#	Component	Description	Value
RY31	HSL4A004ZU	RELAY	OSA-SS-212DM3
RY32	HSL4A004ZU	RELAY	OSA-SS-212DM3
RY33	HSL4A004ZU	RELAY	OSA-SS-212DM3
R105	CRQ1AJR47H	RES , FUSE	
R108	CRG1ANJ100H	RES , METAL OXIDE FILM	10 OHM 1W J
R355	CRF5EKR22HX2	RES , CEMENT	0.22OHM(*2), 5W
R356	CRF5EKR22HX2	RES , CEMENT	0.22OHM(*2), 5W
R375	CRG1ANJ100H	RES , METAL OXIDE FILM	10 OHM 1W J
R376	CRG1ANJ100H	RES , METAL OXIDE FILM	10 OHM 1W J
R377	CRG2ANJ271H	RES , METAL OXIDE FILM(2W/270 OHM)	
R378	CRG2ANJ271H	RES , METAL OXIDE FILM(2W/270 OHM)	
SW21	KSS2B016Z	SWITCH , SLIDE	
SW22	KSS2B016Z	SWITCH , SLIDE	
TH31	KRTP42T7D330B	THERMAL SENSOR , POSISTOR	P42T7D330BW20
T102	CLT5J033YE	TRANS , SUB	
Input PCB Ass'y			
Ref#	Component	Description	Value
	COP12061E	HK3490/230 INPUT PCB ASS'Y	
C301	CCUS1H101JA	CAP , CHIP	100PF 50V J
C302	CCUS1H101JA	CAP , CHIP	100PF 50V J
C305	CCUS1H101JA	CAP , CHIP	100PF 50V J
C306	CCUS1H101JA	CAP , CHIP	100PF 50V J
C321	CCUS1H101JA	CAP , CHIP	100PF 50V J
C322	CCUS1H101JA	CAP , CHIP	100PF 50V J
C323	CCUS1H101JA	CAP , CHIP	100PF 50V J
C324	CCUS1H101JA	CAP , CHIP	100PF 50V J
C325	CCUS1H101JA	CAP , CHIP	100PF 50V J
C326	CCUS1H101JA	CAP , CHIP	100PF 50V J
C327	CCUS1H101JA	CAP , CHIP	100PF 50V J
C328	CCUS1H101JA	CAP , CHIP	100PF 50V J
C329	CCUS1H101JA	CAP , CHIP	100PF 50V J
C330	CCUS1H101JA	CAP , CHIP	100PF 50V J
C331	CCUS1H101JA	CAP , CHIP	100PF 50V J
C332	CCUS1H101JA	CAP , CHIP	100PF 50V J
C333	CCUS1H101JA	CAP , CHIP	100PF 50V J
C344	CCUS1H101JA	CAP , CHIP	100PF 50V J
C347	CCUS1H101JA	CAP , CHIP	100PF 50V J
C348	CCUS1H101JA	CAP , CHIP	100PF 50V J
C349	CCUS1H101JA	CAP , CHIP	100PF 50V J
C350	CCUS1H101JA	CAP , CHIP	100PF 50V J
C351	CCUS1H101JA	CAP , CHIP	100PF 50V J
C352	CCUS1H101JA	CAP , CHIP	100PF 50V J
C369	CCUS1H104KC	CAP , CHIP	0.1UF 50V K
C370	CCUS1H104KC	CAP , CHIP	0.1UF 50V K
C371	CCUS1H101JA	CAP , CHIP	100PF 50V J
C372	CCUS1H101JA	CAP , CHIP	100PF 50V J
C373	CCUS1H101JA	CAP , CHIP	100PF 50V J
C386	CCUS1H104KC	CAP , CHIP	0.1UF 50V K
C387	CCUS1H104KC	CAP , CHIP	0.1UF 50V K
C394	CCUS1H104KC	CAP , CHIP	0.1UF 50V K
C395	CCUS1H104KC	CAP , CHIP	0.1UF 50V K
C400	CCUS1H104KC	CAP , CHIP	0.1UF 50V K
C401	CCUS1H104KC	CAP , CHIP	0.1UF 50V K
C404	CCUS1H104KC	CAP , CHIP	0.1UF 50V K
C405	CCUS1H104KC	CAP , CHIP	0.1UF 50V K
C406	CCUS1A105KC	CAP , CHIP	1UF 10V K
C407	CCUS1A105KC	CAP , CHIP	1UF 10V K
C408	CCUS1A105KC	CAP , CHIP	1UF 10V K
C410	CCUS1H104KC	CAP , CHIP	0.1UF 50V K
C411	CCUS1H104KC	CAP , CHIP	0.1UF 50V K
C413	CCUS1H104KC	CAP , CHIP	0.1UF 50V K
C505	CCUS1H104KC	CAP , CHIP	0.1UF 50V K
C507	CCUS1H104KC	CAP , CHIP	0.1UF 50V K
C508	CCUS1H270JA	CAP , CHIP	27PF 50V J

Input PCB Ass'y			
Ref#	Component	Description	Value
C509	CCUS1H270JA	CAP , CHIP	27PF 50V J
C510	CCUS1H104KC	CAP , CHIP	0.1UF 50V K
C513	CCUS1H104KC	CAP , CHIP	0.1UF 50V K
C515	CCUS1H104KC	CAP , CHIP	0.1UF 50V K
C516	CCUS1H151JA	CAP , CHIP	150PF 50V J
C518	CCUS1H104KC	CAP , CHIP	0.1UF 50V K
C520	CCUS1H104KC	CAP , CHIP	0.1UF 50V K
C525	CCUS1H104KC	CAP , CHIP	0.1UF 50V K
C526	CCUS1H561JA	CAP , CHIP	560PF 50V J
C528	CCUS1H103KC	CAP , CHIP	0.01UF 50V K
C529	CCUS1H103KC	CAP , CHIP	0.01UF 50V K
C530	CCUS1H390JA	CAP , CHIP	39PF 50V J
C531	CCUS1H390JA	CAP , CHIP	39PF 50V J
C532	CCUS1H104KC	CAP , CHIP	0.1UF 50V K
C533	CCUS1H104KC	CAP , CHIP	0.1UF 50V K
C540	CCUS1A105KC	CAP , CHIP	1UF 10V K
C541	CCUS1A105KC	CAP , CHIP	1UF 10V K
C542	CCUS1A105KC	CAP , CHIP	1UF 10V K
C543	CCUS1A105KC	CAP , CHIP	1UF 10V K
C544	CCUS1A105KC	CAP , CHIP	1UF 10V K
C545	CCUS1A105KC	CAP , CHIP	1UF 10V K
C546	CCUS1A105KC	CAP , CHIP	1UF 10V K
D301	CVD1SS355T	DIODE , CHIP	
D302	CVD1SS355T	DIODE , CHIP	
D303	CVD1SS355T	DIODE , CHIP	
D304	CVD1SS355T	DIODE , CHIP	
D305	CVD1SS355T	DIODE , CHIP	
D306	CVD1SS355T	DIODE , CHIP	
D307	CVD1SS355T	DIODE , CHIP	
D308	CVD1SS355T	DIODE , CHIP	
D309	CVD1SS355T	DIODE , CHIP	
D310	CVD1SS355T	DIODE , CHIP	
D311	CVD1SS355T	DIODE , CHIP	
D312	CVD1SS355T	DIODE , CHIP	
D313	CVD1SS355T	DIODE , CHIP	
D314	CVD1SS355T	DIODE , CHIP	
D315	CVD1SS355T	DIODE , CHIP	
D316	CVD1SS355T	DIODE , CHIP	
D319	CVD1SS355T	DIODE , CHIP	
D320	CVD1SS355T	DIODE , CHIP	
D321	CVD1SS355T	DIODE , CHIP	
D322	CVD1SS355T	DIODE , CHIP	
D323	CVD1SS355T	DIODE , CHIP	
D324	CVD1SS355T	DIODE , CHIP	
D325	CVD1SS355T	DIODE , CHIP	
D326	CVD1SS355T	DIODE , CHIP	
D327	CVD1SS355T	DIODE , CHIP	
D328	CVD1SS355T	DIODE , CHIP	
D329	CVD1SS355T	DIODE , CHIP	
D330	CVD1SS355T	DIODE , CHIP	
D331	CVD1SS355T	DIODE , CHIP	
D332	CVD1SS355T	DIODE , CHIP	
D333	CVD1SS355T	DIODE , CHIP	
D334	CVD1SS355T	DIODE , CHIP	
D502	CVD1SS355T	DIODE , CHIP	
D504	CVD1SS355T	DIODE , CHIP	
D505	CVD1SS355T	DIODE , CHIP	
D506	CVD1SS355T	DIODE , CHIP	
D508	CVD1SS355T	DIODE , CHIP	
IC30	HVINJM2068MDTE1	I.C , OP AMP	NJM2068MD-TE1
IC31	HVITC9163CFG	I.C , FUNCTION SW	
IC32	HVITC9164CFG	I.C , FUNCTION SW	
IC33	HVINJM2068MDTE1	I.C , OP AMP	NJM2068MD-TE1
IC34	HVINJM2068MDTE1	I.C , OP AMP	NJM2068MD-TE1
IC35	HVITC9459BFG	I.C , 2CH VOLUME	

Input PCB Ass'y			
Ref#	Component	Description	Value
IC36	HVINJM2068MDTE1	I.C , OP AMP	NJM2068MD-TE1
IC37	HVINJM2068MDTE1	I.C , OP AMP	NJM2068MD-TE1
IC38	HVINJM2068MDTE1	I.C , OP AMP	NJM2068MD-TE1
IC51	CVIT5CD2	I.C , U-COM	
IC52	HVIAT24C08N10SC	I.C	AT24C08N10SC2.7
IC53	HVITC74VHCT08FT	IC , AND-GATE	TC74VHCT08FT
IC54	HVITC74VHCT08FT	IC , AND-GATE	TC74VHCT08FT
IC56	HVISAA6579TV1	I.C , RDS FILTER	TW
IC57	HVIS-80145ALMC	I.C RESET	S-80145ALMC
Q301	HVTKRA107S	TR, CHIP	
Q302	HVTKRC107S	T.R , CHIP	
Q308	HVTKRA107S	TR, CHIP	
Q309	HVTKRA107S	TR, CHIP	
Q310	HVTKRC107S	T.R , CHIP	
Q311	HVTKRC107S	T.R , CHIP	
Q312	HVTKRA107S	TR, CHIP	
Q313	HVTKRA107S	TR, CHIP	
Q501	HVTKRC107S	T.R , CHIP	
Q505	HVTKTA2014GR	T.R , CHIP	TRPNPB-R2
Q506	HVTKTC3875SYRTK	T.R , CHIP	KTC3875S Y RTK
R301	CRJ10DJ102T	RES , CHIP	1608 SIZE
R302	CRJ10DJ102T	RES , CHIP	1608 SIZE
R303	CRJ10DJ104T	RES , CHIP	1608 SIZE
R304	CRJ10DJ104T	RES , CHIP	1608 SIZE
R305	CRJ10DJ104T	RES , CHIP	1608 SIZE
R306	CRJ10DJ104T	RES , CHIP	1608 SIZE
R307	CRJ10DJ564T	RES , CHIP	1608 SIZE
R308	CRJ10DJ564T	RES , CHIP	1608 SIZE
R309	CRJ10DJ473T	RES , CHIP	1608 SIZE
R310	CRJ10DJ473T	RES , CHIP	1608 SIZE
R311	CRJ10DJ681T	RES , CHIP	1608 SIZE
R312	CRJ10DJ681T	RES , CHIP	1608 SIZE
R313	CRJ10DJ471T	RES , CHIP	1608 SIZE
R314	CRJ10DJ471T	RES , CHIP	1608 SIZE
R315	CRJ10DJ473T	RES , CHIP	1608 SIZE
R316	CRJ10DJ473T	RES , CHIP	1608 SIZE
R317	CRJ10DJ821T	RES , CHIP	1608 SIZE
R318	CRJ10DJ821T	RES , CHIP	1608 SIZE
R319	CRJ10DJ471T	RES , CHIP	1608 SIZE
R320	CRJ10DJ471T	RES , CHIP	1608 SIZE
R321	CRJ10DJ473T	RES , CHIP	1608 SIZE
R322	CRJ10DJ473T	RES , CHIP	1608 SIZE
R323	CRJ10DJ471T	RES , CHIP	1608 SIZE
R324	CRJ10DJ471T	RES , CHIP	1608 SIZE
R325	CRJ10DJ473T	RES , CHIP	1608 SIZE
R326	CRJ10DJ473T	RES , CHIP	1608 SIZE
R327	CRJ10DJ471T	RES , CHIP	1608 SIZE
R328	CRJ10DJ471T	RES , CHIP	1608 SIZE
R329	CRJ10DJ473T	RES , CHIP	1608 SIZE
R330	CRJ10DJ473T	RES , CHIP	1608 SIZE
R331	CRJ10DJ471T	RES , CHIP	1608 SIZE
R332	CRJ10DJ471T	RES , CHIP	1608 SIZE
R333	CRJ10DJ473T	RES , CHIP	1608 SIZE
R334	CRJ10DJ473T	RES , CHIP	1608 SIZE
R335	CRJ10DJ471T	RES , CHIP	1608 SIZE
R336	CRJ10DJ471T	RES , CHIP	1608 SIZE
R337	CRJ10DJ473T	RES , CHIP	1608 SIZE
R338	CRJ10DJ473T	RES , CHIP	1608 SIZE
R339	CRJ10DJ471T	RES , CHIP	1608 SIZE
R340	CRJ10DJ471T	RES , CHIP	1608 SIZE
R341	CRJ10DJ473T	RES , CHIP	1608 SIZE
R342	CRJ10DJ473T	RES , CHIP	1608 SIZE
R343	CRJ10DJ471T	RES , CHIP	1608 SIZE
R344	CRJ10DJ471T	RES , CHIP	1608 SIZE
R355	CRJ10DJ473T	RES , CHIP	1608 SIZE

Input PCB Ass'y			
Ref#	Component	Description	Value
R366	CRJ10DJ473T	RES , CHIP	1608 SIZE
R367	CRJ10DJ101T	RES , CHIP	1608 SIZE
R368	CRJ10DJ101T	RES , CHIP	1608 SIZE
R369	CRJ10DJ101T	RES , CHIP	1608 SIZE
R370	CRJ10DJ101T	RES , CHIP	1608 SIZE
R371	CRJ10DJ101T	RES , CHIP	1608 SIZE
R372	CRJ10DJ101T	RES , CHIP	1608 SIZE
R373	CRJ10DJ682T	RES , CHIP	1608 SIZE
R374	CRJ10DJ682T	RES , CHIP	1608 SIZE
R375	CRJ10DJ473T	RES , CHIP	1608 SIZE
R376	CRJ10DJ473T	RES , CHIP	1608 SIZE
R377	CRJ10DJ473T	RES , CHIP	1608 SIZE
R378	CRJ10DJ473T	RES , CHIP	1608 SIZE
R379	CRJ10DJ473T	RES , CHIP	1608 SIZE
R380	CRJ10DJ473T	RES , CHIP	1608 SIZE
R381	CRJ10DJ101T	RES , CHIP	1608 SIZE
R382	CRJ10DJ101T	RES , CHIP	1608 SIZE
R383	CRJ10DJ101T	RES , CHIP	1608 SIZE
R384	CRJ10DJ473T	RES , CHIP	1608 SIZE
R385	CRJ10DJ473T	RES , CHIP	1608 SIZE
R386	CRJ10DJ471T	RES , CHIP	1608 SIZE
R387	CRJ10DJ471T	RES , CHIP	1608 SIZE
R388	CRJ10DJ473T	RES , CHIP	1608 SIZE
R389	CRJ10DJ473T	RES , CHIP	1608 SIZE
R390	CRJ10DJ112T	RES , CHIP	
R391	CRJ10DJ112T	RES , CHIP	
R392	CRJ10DJ102T	RES , CHIP	1608 SIZE
R393	CRJ10DJ102T	RES , CHIP	1608 SIZE
R394	CRJ10DJ152T	RES , CHIP	1608 SIZE
R395	CRJ10DJ152T	RES , CHIP	1608 SIZE
R396	CRJ10DJ473T	RES , CHIP	1608 SIZE
R397	CRJ10DJ473T	RES , CHIP	1608 SIZE
R398	CRJ10DJ332T	RES , CHIP	1608 SIZE
R399	CRJ10DJ105T	RES , CHIP	1608 SIZE
R400	CRJ10DJ473T	RES , CHIP	1608 SIZE
R401	CRJ10DJ473T	RES , CHIP	1608 SIZE
R402	CRJ10DJ473T	RES , CHIP	1608 SIZE
R403	CRJ10DJ473T	RES , CHIP	1608 SIZE
R404	CRJ10DJ102T	RES , CHIP	1608 SIZE
R405	CRJ10DJ102T	RES , CHIP	1608 SIZE
R406	CRJ10DJ105T	RES , CHIP	1608 SIZE
R407	CRJ10DJ105T	RES , CHIP	1608 SIZE
R408	CRJ10DJ0R0T	RES , CHIP	1608 SIZE
R409	CRJ10DJ0R0T	RES , CHIP	1608 SIZE
R410	CRJ10DJ562T	RES , CHIP	1608 SIZE
R412	CRJ10DJ332T	RES , CHIP	1608 SIZE
R413	CRJ10DJ332T	RES , CHIP	1608 SIZE
R414	CRJ10DJ0R0T	RES , CHIP	1608 SIZE
R415	CRJ10DJ332T	RES , CHIP	1608 SIZE
R416	CRJ10DJ332T	RES , CHIP	1608 SIZE
R417	CRJ10DJ562T	RES , CHIP	1608 SIZE
R418	CRJ10DJ562T	RES , CHIP	1608 SIZE
R419	CRJ10DJ101T	RES , CHIP	1608 SIZE
R420	CRJ10DJ101T	RES , CHIP	1608 SIZE
R501	CRJ10DJ562T	RES , CHIP	1608 SIZE
R503	CRJ10DJ103T	RES , CHIP	1608 SIZE
R504	CRJ10DJ103T	RES , CHIP	1608 SIZE
R505	CRJ10DJ101T	RES , CHIP	1608 SIZE
R506	CRJ10DJ101T	RES , CHIP	1608 SIZE
R507	CRJ10DJ103T	RES , CHIP	1608 SIZE
R508	CRJ10DJ105T	RES , CHIP	1608 SIZE
R509	CRJ10DJ0R0T	RES , CHIP	1608 SIZE
R510	CRJ10DJ103T	RES , CHIP	1608 SIZE
R511	CRJ10DJ103T	RES , CHIP	1608 SIZE
R512	CRJ10DJ103T	RES , CHIP	1608 SIZE

Input PCB Ass'y			
Ref#	Component	Description	Value
R513	CRJ10DJ103T	RES , CHIP	1608 SIZE
R514	CRJ10DJ103T	RES , CHIP	1608 SIZE
R515	CRJ10DJ103T	RES , CHIP	1608 SIZE
R516	CRJ10DJ103T	RES , CHIP	1608 SIZE
R517	CRJ10DJ103T	RES , CHIP	1608 SIZE
R518	CRJ10DJ103T	RES , CHIP	1608 SIZE
R519	CRJ10DJ103T	RES , CHIP	1608 SIZE
R520	CRJ10DJ103T	RES , CHIP	1608 SIZE
R522	CRJ10DJ103T	RES , CHIP	1608 SIZE
R523	CRJ10DJ103T	RES , CHIP	1608 SIZE
R524	CRJ10DJ103T	RES , CHIP	1608 SIZE
R525	CRJ10DJ103T	RES , CHIP	1608 SIZE
R526	CRJ10DJ103T	RES , CHIP	1608 SIZE
R527	CRJ10DJ473T	RES , CHIP	1608 SIZE
R528	CRJ10DJ100T	RES , CHIP	1608 SIZE
R529	CRJ10DJ222T	RES , CHIP	1608 SIZE
R530	CRJ10DJ100T	RES , CHIP	1608 SIZE
R531	CRJ10DJ102T	RES , CHIP	1608 SIZE
R532	CRJ10DJ102T	RES , CHIP	1608 SIZE
R533	CRJ10DJ123T	RES , CHIP	1608 SIZE
R534	CRJ10DJ152T	RES , CHIP	1608 SIZE
R535	CRJ10DJ273T	RES , CHIP	
R536	CRJ10DJ333T	RES , CHIP	1608 SIZE
R537	CRJ10DJ183T	RES , CHIP	1608 SIZE
R538	CRJ10DJ223T	RES , CHIP	1608 SIZE
R539	CRJ10DJ103T	RES , CHIP	1608 SIZE
R540	CRJ10DJ100T	RES , CHIP	1608 SIZE
R541	CRJ10DJ100T	RES , CHIP	1608 SIZE
R542	CRJ10DJOROT	RES , CHIP(N.G)	
R543	CRJ10DJOROT	RES , CHIP(N.G)	
C303	CCEA1HH100T	CAP , ELECT	10UF 50V
C304	CCEA1HH100T	CAP , ELECT	10UF 50V
C307	CCEA1EH470T	CAP , ELECT	47UF 25V
C308	CCEA1EH470T	CAP , ELECT	47UF 25V
C309	HCQ11H102JZT	CAP , MYLAR	1000PF 50V J
C310	HCQ11H102JZT	CAP , MYLAR	1000PF 50V J
C311	CCEA1CH101T	CAP , ELECT	100UF 16V
C312	CCEA1CH101T	CAP , ELECT	100UF 16V
C313	HCQ11H562JZT	CAP , MYLAR	5600PF 50V J
C314	HCQ11H562JZT	CAP , MYLAR	5600PF 50V J
C315	HCQ11H152JZT	CAP , MYLAR	1500PF 50V J
C316	HCQ11H152JZT	CAP , MYLAR	1500PF 50V J
C317	CCEA1HH100T	CAP , ELECT	10UF 50V
C318	CCEA1HH100T	CAP , ELECT	10UF 50V
C319	HCQ11H183JZT	CAP , MYLAR	0.018UF 50V J
C320	HCQ11H183JZT	CAP , MYLAR	0.018UF 50V J
C345	CCEA1EH101T	CAP , ELECT	100UF 25V
C346	CCEA1EH101T	CAP , ELECT	100UF 25V
C353	CCEA1HH4R7T	CAP , ELECT	4.7UF 50V
C354	CCEA1HH4R7T	CAP , ELECT	4.7UF 50V
C355	CCEA1HH4R7T	CAP , ELECT	4.7UF 50V
C356	CCEA1HH4R7T	CAP , ELECT	4.7UF 50V
C357	CCEA1HH4R7T	CAP , ELECT	4.7UF 50V
C358	CCEA1HH4R7T	CAP , ELECT	4.7UF 50V
C359	CCEA1HH4R7T	CAP , ELECT	4.7UF 50V
C360	CCEA1HH4R7T	CAP , ELECT	4.7UF 50V
C361	CCEA1EH470T	CAP , ELECT	47UF 25V
C362	CCEA1EH470T	CAP , ELECT	47UF 25V
C363	CCEA1HH4R7T	CAP , ELECT	4.7UF 50V
C364	CCEA1HH4R7T	CAP , ELECT	4.7UF 50V
C365	CCEA1HH4R7T	CAP , ELECT	4.7UF 50V
C366	CCEA1HH4R7T	CAP , ELECT	4.7UF 50V
C367	CCEA1EH470T	CAP , ELECT	47UF 25V
C368	CCEA1EH470T	CAP , ELECT	47UF 25V
C374	CCEA1HH4R7T	CAP , ELECT	4.7UF 50V

Input PCB Ass'y			
Ref#	Component	Description	Value
C375	CCEA1HH4R7T	CAP , ELECT	4.7UF 50V
C376	CCEA1EH101T	CAP , ELECT	100UF 25V
C377	CCEA1EH101T	CAP , ELECT	100UF 25V
C378	CCEA1HH4R7T	CAP , ELECT	4.7UF 50V
C379	CCEA1HH4R7T	CAP , ELECT	4.7UF 50V
C380	HCQ11H102JZT	CAP , MYLAR	1000PF 50V J
C381	HCQ11H102JZT	CAP , MYLAR	1000PF 50V J
C382	CCEA1HH4R7T	CAP , ELECT	4.7UF 50V
C383	CCEA1HH4R7T	CAP , ELECT	4.7UF 50V
C384	CCEA1EH101T	CAP , ELECT	100UF 25V
C385	CCEA1EH101T	CAP , ELECT	100UF 25V
C388	CCEA1HH100T	CAP , ELECT	10UF 50V
C389	CCEA1HH100T	CAP , ELECT	10UF 50V
C390	CCEA1HH100T	CAP , ELECT	10UF 50V
C391	CCEA1HH100T	CAP , ELECT	10UF 50V
C392	CCEA1EH101T	CAP , ELECT	100UF 25V
C393	CCEA1EH101T	CAP , ELECT	100UF 25V
C396	CCEA1EH101T	CAP , ELECT	100UF 25V
C397	CCEA1HHR22T	CAP , ELECT	0.22UF 50V
C398	CCEA1EH101T	CAP , ELECT	100UF 25V
C399	CCEA1EH101T	CAP , ELECT	100UF 25V
C402	CCEA1CH101T	CAP , ELECT	100UF 16V
C403	CCEA1CH101T	CAP , ELECT	100UF 16V
C501	CCEA0JH102T	CAP , ELECT	1000UF 6.3V
C502	CCEA1CH101T	CAP , ELECT	100UF 16V
C503	CCEA1CH101T	CAP , ELECT	100UF 16V
C504	CCEA1HH100T	CAP , ELECT	10UF 50V
C506	CCEA1HH100T	CAP , ELECT	10UF 50V
C514	CCEA1AH101T	CAP , ELECT	100UF 10V
C517	CCEA1HH100T	CAP , ELECT	10UF 50V
C519	CCEA1HH100T	CAP , ELECT	10UF 50V
C523	CCEA1HH100T	CAP , ELECT	10UF 50V
C524	CCEA1HH100T	CAP , ELECT	10UF 50V
C527	CCEA1HH2R2T	CAP , ELECT	2.2UF 50V
D317	CVD1N4003SRT	DIODE , RECT	1N4003
D318	CVD1N4003SRT	DIODE , RECT	1N4003
D501	CVD1N4003SRT	DIODE , RECT	1N4003
D503	CVD1N4003SRT	DIODE , RECT	1N4003
D507	CVDZJ4.3BT	DIODE , ZENER	ZJ4.3B 1/2W
Q303	HVTKTC2874BT	T.R , MUTE	KTC2874B
Q304	HVTKTC2874BT	T.R , MUTE	KTC2874B
Q305	HVTKTC2874BT	T.R , MUTE	KTC2874B
Q306	HVTKTC2874BT	T.R , MUTE	KTC2874B
Q307	HVTKTC2874BT	T.R , MUTE	KTC2874B
Q502	HVTKRA107MT	T.R	KRA107M
BN51	CWE8202120AA	WIRE , 1P BLACK(120MM)	
CB51	CJP21GA117ZY	WAFER	
CB52	CJP19GA117ZY	CARD CABLE , WAFER	
CN21	CJP17GA115ZY	WAFER , CARDCABLE	
CN22	CJP11GA19ZY	WAFER , STRAIGHT	
CN24	CJP05GA19ZY	WAFER , STRAIGHT	
CN26	CJP13GA115ZY	WAFER , CARD CABLE	
CN84	CJP05GA19ZY	WAFER , STRAIGHT	
CN85	CJP17GA117ZY	WAFER	
CN87	CJP19GA115ZY	WAFER	
C412	CCEA1EH102E	CAP , ELECT	1000UF 25V
IC39	HVIKIA7808API	I.C , REGULATOR +8V	KIA7808 (KEC)
IC40	CVIKIA7908PI	I.C , REGULATOR(TO-220IS)	KIA7908PI TO-220IS
JK10	CJJ4N060Z	JACK , BOARD 2P (GOLD)	
JK11	CJJ4R019W	TERMINAL , IN/OUT	
JK12	CJJ4P014W	JACK , IN/OUT	
JK13	CJJ4P014W	JACK , IN/OUT	
L301	CLU9S004Z	COIL , TOROIDAL	
L302	CLU9S004Z	COIL , TOROIDAL	
X501	HOX20000E220C	CRYSTAL	20MHZ

Input PCB Ass'y			
Ref#	Component	Description	Value
X502	HOX04332A200C	CRYSTAL	
DSP PCB Ass'y			
Ref#	Component	Description	Value
	COP12062E	HK3490/230 DSP PCB ASS'Y	
C501	CCUS1H181JA	CAP , CHIP	180PF 50V J
C502	CCUS1H104KC	CAP , CHIP	0.1UF 50V K
C503	CCUS1H104KC	CAP , CHIP	0.1UF 50V K
C506	CCUS1H104KC	CAP , CHIP	0.1UF 50V K
C509	CCUS1H104KC	CAP , CHIP	0.1UF 50V K
C510	CCUS1H220JA	CAP , CHIP	22PF 50V J
C511	CCUS1H220JA	CAP , CHIP	22PF 50V J
C513	CCUS1H102KC	CAP , CHIP	1000PF 50V K
C514	CCUS1H104KC	CAP , CHIP	0.1UF 50V K
C515	CCUS1H104KC	CAP , CHIP	0.1UF 50V K
C517	CCUS1H104KC	CAP , CHIP	0.1UF 50V K
C519	CCUS1H104KC	CAP , CHIP	0.1UF 50V K
C522	CCUS1H104KC	CAP , CHIP	0.1UF 50V K
C523	CCUS1H104KC	CAP , CHIP	0.1UF 50V K
C525	CCUS1H104KC	CAP , CHIP	0.1UF 50V K
C528	CCUS1H104KC	CAP , CHIP	0.1UF 50V K
C529	CCUS1H104KC	CAP , CHIP	0.1UF 50V K
C532	CCUS1H104KC	CAP , CHIP	0.1UF 50V K
C533	CCUS1H104KC	CAP , CHIP	0.1UF 50V K
C535	CCUS1H272KC	CAP , CHIP	2700PF 50V K
C536	CCUS1H272KC	CAP , CHIP	2700PF 50V K
C537	CCUS1H391JA	CAP , CHIP	390PF 50V J
C538	CCUS1H391JA	CAP , CHIP	390PF 50V J
C539	CCUS1H272KC	CAP , CHIP	2700PF 50V K
C540	CCUS1H272KC	CAP , CHIP	2700PF 50V K
C541	CCUS1H104KC	CAP , CHIP	0.1UF 50V K
C542	CCUS1H391JA	CAP , CHIP	390PF 50V J
C543	CCUS1H391JA	CAP , CHIP	390PF 50V J
C544	CCUS1H104KC	CAP , CHIP	0.1UF 50V K
C549	CCUS1H104KC	CAP , CHIP	0.1UF 50V K
C551	CCUS1H104KC	CAP , CHIP	0.1UF 50V K
C552	CCUS1H104KC	CAP , CHIP	0.1UF 50V K
C554	CCUS1H104KC	CAP , CHIP	0.1UF 50V K
C555	CCUS1H104KC	CAP , CHIP	0.1UF 50V K
C569	CCUS1H104KC	CAP , CHIP	0.1UF 50V K
C570	CCUS1H104KC	CAP , CHIP	0.1UF 50V K
C571	CCUS1H471JA	CAP , CHIP	470PF 50V J
C572	CCUS1H471JA	CAP , CHIP	470PF 50V J
C612	CCUS1H220JA	CAP , CHIP	22PF 50V J
C613	CCUS1H223KC	CAP , CHIP	0.022UF 50V K
C614	CCUS1H220JA	CAP , CHIP	22PF 50V J
C615	CCUS1H471JA	CAP , CHIP	470PF 50V J
C616	CCUS1H471JA	CAP , CHIP	470PF 50V J
C619	CCUS1H223KC	CAP , CHIP	0.022UF 50V K
C622	CCUS1H473KC	CAP , CHIP	0.047UF 50V K
C623	CCUS1H223KC	CAP , CHIP	0.022UF 50V K
C785	CCUS1H104KC	CAP , CHIP	0.1UF 50V K
C786	CCUS1H104KC	CAP , CHIP	0.1UF 50V K
C787	CCUS1H104KC	CAP , CHIP	0.1UF 50V K
C788	CCUS1H104KC	CAP , CHIP	0.1UF 50V K
C789	CCUS1H104KC	CAP , CHIP	0.1UF 50V K
C970	CCUS1H104KC	CAP , CHIP	0.1UF 50V K
C971	CCUS1H104KC	CAP , CHIP	0.1UF 50V K
IC44	HVINJM2068MDTE1	I.C , OP AMP	NJM2068MD-TE1
IC51	CVIKIA1117S18	I.C , REGULATOR(SOT-223)	KIA1117S/F18, SOT-223
IC52	CVIKIA1117S33	I.C , REGULATOR(SOT-223)	KIA1117S/F33, SOT-223
IC53	HVIAK4589VQ-T	I.C , CODEC + DIR	AK4589VQ
IC54	CVICS48560CQZ	I.C , DSP	CS48560-CQZ
IC55	HVI74HCU04AFNG	I.C , INVERTER	TC74HCU04AFNG(TOSHIBA)
IC62	HVINJM2068MDTE1	I.C , OP AMP	NJM2068MD-TE1

DSP PCB Ass'y			
Ref#	Component	Description	Value
IC63	HVINJM2068MDTE1	I.C , OP AMP	NJM2068MD-TE1
JK61	HJJ9L003Z	JACK , IPOD	
L500	CLZ9Z014Z	FERRITE , CHIP BEAD(60ohm, 4516)	HCB4516KF-600T60
L501	CLZ9Z014Z	FERRITE , CHIP BEAD(60ohm, 4516)	HCB4516KF-600T60
L503	CLZ9Z014Z	FERRITE , CHIP BEAD(60ohm, 4516)	HCB4516KF-600T60
L504	CLZ9Z014Z	FERRITE , CHIP BEAD(60ohm, 4516)	HCB4516KF-600T60
L505	CLZ9Z014Z	FERRITE , CHIP BEAD(60ohm, 4516)	HCB4516KF-600T60
L601	CLZ9Z014Z	FERRITE , CHIP BEAD(60ohm, 4516)	HCB4516KF-600T60
Q601	HVTKRC102S	T.R , CHIP	KRC102S
R501	CRJ10DJ103T	RES , CHIP	1608 SIZE
R502	CRJ10DJ750T	RES , CHIP	1608 SIZE
R503	CRJ10DJ102T	RES , CHIP	1608 SIZE
R504	CRJ10DJ104T	RES , CHIP	1608 SIZE
R505	CRJ10DJ104T	RES , CHIP	1608 SIZE
R506	CRJ10DJ472T	RES , CHIP	1608 SIZE
R507	CRJ10DJ472T	RES , CHIP	1608 SIZE
R508	CRJ10DJ330T	RES , CHIP	1608 SIZE
R509	CRJ10DJ105T	RES , CHIP	1608 SIZE
R510	CRJ10DJ102T	RES , CHIP	1608 SIZE
R514	CRJ10DJ101T	RES , CHIP	1608 SIZE
R515	CRJ10DJ473T	RES , CHIP	1608 SIZE
R517	CRJ10DF1202T	RES , CHIP 1%	
R518	CRJ10DJ473T	RES , CHIP	1608 SIZE
R520	CRJ10DJ473T	RES , CHIP	1608 SIZE
R521	CRJ10DJ0R0T	RES , CHIP	1608 SIZE
R525	CRJ10DJ332T	RES , CHIP	1608 SIZE
R526	CRJ10DJ332T	RES , CHIP	1608 SIZE
R527	CRJ10DJ330T	RES , CHIP	1608 SIZE
R528	CRJ10DJ330T	RES , CHIP	1608 SIZE
R530	CRJ10DF5101T	RES. CHIP (5.1K 1%)	1608 SIZE
R531	CRJ10DJ0R0T	RES , CHIP	1608 SIZE
R532	CRJ10DJ332T	RES , CHIP	1608 SIZE
R533	CRJ10DJ332T	RES , CHIP	1608 SIZE
R534	CRJ10DJ102T	RES , CHIP	1608 SIZE
R535	CRJ10DJ330T	RES , CHIP	1608 SIZE
R536	CRJ10DJ330T	RES , CHIP	1608 SIZE
R537	CRJ10DJ330T	RES , CHIP	1608 SIZE
R538	CRJ10DJ330T	RES , CHIP	1608 SIZE
R539	CRJ10DJ330T	RES , CHIP	1608 SIZE
R540	CRJ10DJ330T	RES , CHIP	1608 SIZE
R541	CRJ10DJ330T	RES , CHIP	1608 SIZE
R542	CRJ10DJ330T	RES , CHIP	1608 SIZE
R543	CRJ10DJ103T	RES , CHIP	1608 SIZE
R544	CRJ10DJ222T	RES , CHIP	1608 SIZE
R545	CRJ10DJ222T	RES , CHIP	1608 SIZE
R546	CRJ10DJ222T	RES , CHIP	1608 SIZE
R547	CRJ10DJ330T	RES , CHIP	1608 SIZE
R548	CRJ10DJ103T	RES , CHIP	1608 SIZE
R549	CRJ10DJ103T	RES , CHIP	1608 SIZE
R550	CRJ10DJ103T	RES , CHIP	1608 SIZE
R551	CRJ10DJ102T	RES , CHIP	1608 SIZE
R552	CRJ10DJ102T	RES , CHIP	1608 SIZE
R553	CRJ10DJ102T	RES , CHIP	1608 SIZE
R554	CRJ10DJ332T	RES , CHIP	1608 SIZE
R555	CRJ10DJ332T	RES , CHIP	1608 SIZE
R556	CRJ10DJ332T	RES , CHIP	1608 SIZE
R557	CRJ10DJ332T	RES , CHIP	1608 SIZE
R558	CRJ10DJ682T	RES , CHIP	1608 SIZE
R559	CRJ10DJ682T	RES , CHIP	1608 SIZE
R560	CRJ10DJ152T	RES , CHIP	1608 SIZE
R561	CRJ10DJ152T	RES , CHIP	1608 SIZE
R562	CRJ10DJ152T	RES , CHIP	1608 SIZE
R563	CRJ10DJ682T	RES , CHIP	1608 SIZE
R564	CRJ10DJ152T	RES , CHIP	1608 SIZE
R565	CRJ10DJ682T	RES , CHIP	1608 SIZE

DSP PCB Ass'y			
Ref#	Component	Description	Value
R566	CRJ10DJ101T	RES , CHIP	1608 SIZE
R567	CRJ10DJ101T	RES , CHIP	1608 SIZE
R568	CRJ10DJ104T	RES , CHIP	1608 SIZE
R569	CRJ10DJ104T	RES , CHIP	1608 SIZE
R574	CRJ10DJ222T	RES , CHIP	1608 SIZE
R584	CRJ10DJ222T	RES , CHIP	1608 SIZE
R585	CRJ10DJ102T	RES , CHIP	1608 SIZE
R586	CRJ10DJ222T	RES , CHIP	1608 SIZE
R587	CRJ10DJ102T	RES , CHIP	1608 SIZE
R588	CRJ10DJ222T	RES , CHIP	1608 SIZE
R589	CRJ10DJ102T	RES , CHIP	1608 SIZE
R590	CRJ10DJ333T	RES , CHIP	1608 SIZE
R591	CRJ10DJ682T	RES , CHIP	1608 SIZE
R592	CRJ10DJ123T	RES , CHIP	1608 SIZE
R593	CRJ10DJ153T	RES , CHIP	
R594	CRJ10DJ153T	RES , CHIP	
R595	CRJ10DJ152T	RES , CHIP	1608 SIZE
R602	CRJ10DF5493T	RES , CHIP 549KOHM/1608/1%	
R603	CRJ10DJ0R0T	RES , CHIP	1608 SIZE
R610	CRJ10DJ473T	RES , CHIP	1608 SIZE
R613	CRJ10DJ222T	RES , CHIP	1608 SIZE
R614	CRJ10DJ474T	RES , CHIP	1608 SIZE
R615	CRJ10DJ473T	RES , CHIP	1608 SIZE
R616	CRJ18AJ221T	RES , CHIP	
R617	CRJ10DJ103T	RES , CHIP	1608 SIZE
R618	CRJ10DJ103T	RES , CHIP	1608 SIZE
R619	CRJ18AJ221T	RES , CHIP	
R620	CRJ10DJ220T	RES , CHIP	1608 SIZE
R621	CRJ10DJ220T	RES , CHIP	1608 SIZE
R622	CRJ10DJ222T	RES , CHIP	1608 SIZE
R623	CRJ10DJ103T	RES , CHIP	1608 SIZE
R624	CRJ10DJ103T	RES , CHIP	1608 SIZE
R625	CRJ10DJ222T	RES , CHIP	1608 SIZE
R626	CRJ10DJ222T	RES , CHIP	1608 SIZE
R627	CRJ10DJ474T	RES , CHIP	1608 SIZE
R628	CRJ10DJ474T	RES , CHIP	1608 SIZE
R629	CRJ10DJ222T	RES , CHIP	1608 SIZE
R630	CRJ10DJ102T	RES , CHIP	1608 SIZE
R631	CRJ10DJ222T	RES , CHIP	1608 SIZE
C504	CCEA1CH101T	CAP , ELECT	100UF 16V
C505	CCEA1CH101T	CAP , ELECT	100UF 16V
C507	CCEA1CH101T	CAP , ELECT	100UF 16V
C508	CCEA1CH101T	CAP , ELECT	100UF 16V
C516	CCEA1AH471T	CAP , ELECT	470UF 10V
C518	CCEA1HH2R2T	CAP , ELECT	2.2UF 50V
C520	CCEA1AH471T	CAP , ELECT	470UF 10V
C521	CCEA1CH101T	CAP , ELECT	100UF 16V
C524	CCEA1CH101T	CAP , ELECT	100UF 16V
C526	CCEA1CH101T	CAP , ELECT	100UF 16V
C527	CCEA1CH101T	CAP , ELECT	100UF 16V
C530	CCEA1CH101T	CAP , ELECT	100UF 16V
C531	CCEA1CH101T	CAP , ELECT	100UF 16V
C534	CCEA1CH101T	CAP , ELECT	100UF 16V
C545	CCEA1HH100T	CAP , ELECT	10UF 50V
C546	CCEA1HH100T	CAP , ELECT	10UF 50V
C553	CCEA1CH101T	CAP , ELECT	100UF 16V
C556	CCEA0JH102T	CAP , ELECT	1000UF 6.3V
C557	CCEA1CH101T	CAP , ELECT	100UF 16V
C558	CCFT1H473ZF	CAP , CERAMIC	0.047UF 50V Z
C560	CCFT1H473ZF	CAP , CERAMIC	0.047UF 50V Z
C567	CCEA1HH100T	CAP , ELECT	10UF 50V
C568	CCEA1HH100T	CAP , ELECT	10UF 50V
C573	CCEA1HH100T	CAP , ELECT	10UF 50V
C574	CCEA1HH100T	CAP , ELECT	10UF 50V
C575	CCEA1HH100T	CAP , ELECT	10UF 50V

DSP PCB Ass'y			
Ref#	Component	Description	Value
C576	CCEA1HH100T	CAP , ELECT	10UF 50V
C603	CCEA1HH100T	CAP , ELECT	10UF 50V
C604	CCEA1HH100T	CAP , ELECT	10UF 50V
C610	CCEA1HH1R0T	CAP , ELECT	1UF 50V
C617	CCEA1HH100T	CAP , ELECT	10UF 50V
C618	CCEA1HH100T	CAP , ELECT	10UF 50V
C624	CCFT1H473ZF	CAP , CERAMIC	0.047UF 50V Z
C652	CCEA1CH471T	CAP , ELECT	470UF 16V
C654	CCEA1AH331T	CAP , ELECT	330UF 10V
C655	CCEA1CH221T	CAP , ELECT	220UF 16V
C656	CCEA1EH101T	CAP , ELECT	100UF 25V
C658	CCFT1H473ZF	CAP , CERAMIC	0.047UF 50V Z
D504	CVD1N4003ST	DIODE , RECT	1N4003
D505	CVD1N4003ST	DIODE , RECT	1N4003
D506	CVD1N4003ST	DIODE , RECT	1N4003
D507	CVD1N4003ST	DIODE , RECT	1N4003
D508	CVDZJ4.3BT	DIODE , ZENER	ZJ4.3B 1/2W
D602	CVD1N4003ST	DIODE , RECT	1N4003
D603	CVD1N4003ST	DIODE , RECT	1N4003
BK41	CMD1A387	BRACKET , PCB	
BK61	CMD1A570	BRACKET , PCB	
BN51	CWB1C911200EN	WIRE ASS'Y	
CB51	CJP21GA117ZY	WAFER	
CB52	CJP19GA117ZY	CARD CABLE , WAFER	
CN14	CJP13GA19ZY	WAFER, STRAIGHT, 13PIN	
CN51	CJP11GA19ZY	WAFER , STRAIGHT	
C561	CCEA1CH682E	CAP , ELECT	
C562	CCEA1CH682E	CAP , ELECT	
C659	CCEA1VH222E	CAP , ELECT	
IC56	HVIL7805CP	I.C, REGULATOR	
IC64	HVIL7812CP	I.C , REGULATOR	L7812(ST)
JK51	HJSTORX177L	MODULE , OPTICAL(RX)	TORX177L
JK52	CJJ4M041Y	JACK , BOARD (COAX)	
X500	COX24576E180TF	CRYSTAL , 24.576MHz	CRYSTAL_HC-49/S_18PF

ASAHI KASEI

[AK4589]

■ Ordering Guide

AK4589VQ -10 ~ +70°C 80pin LQFP(0.5mm pitch)
 AKD4589 Evaluation Board for AK4589

■ Pin Layout

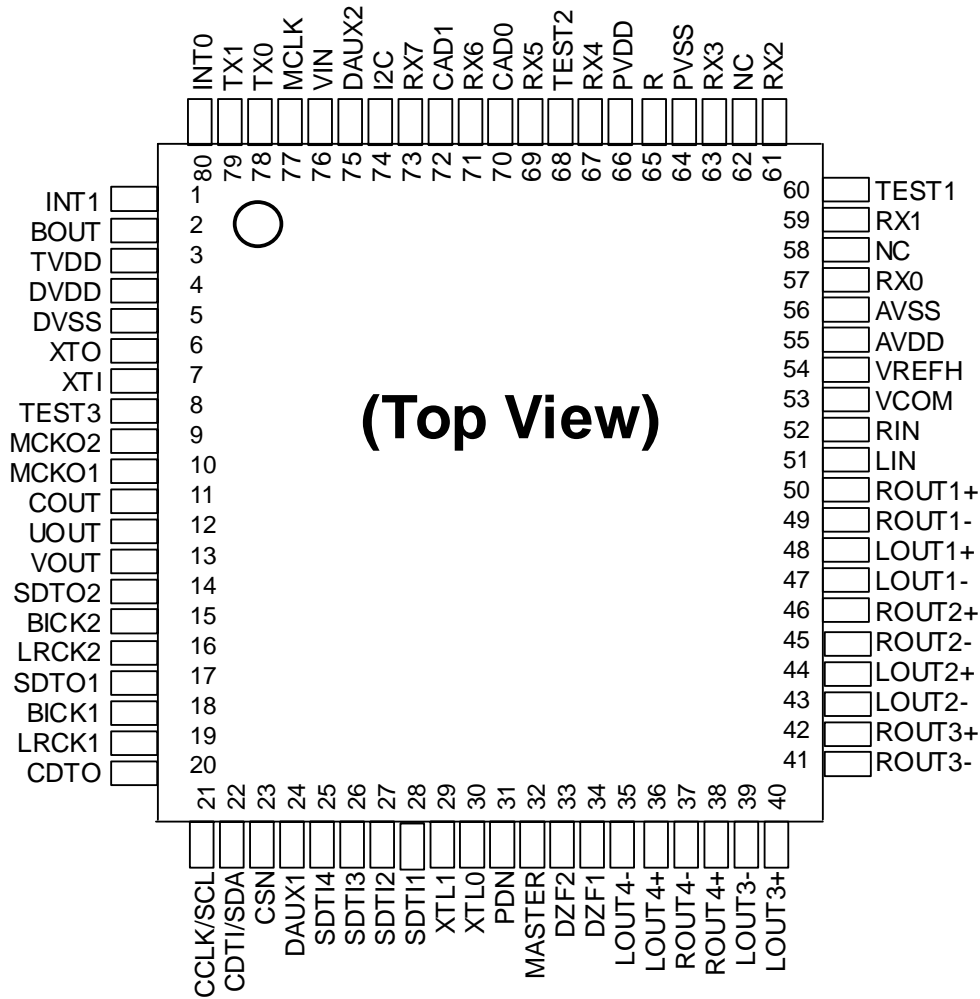

8. Device Pinout Diagrams

8.1 CS48520, 48-pin LQFP Pinout Diagram

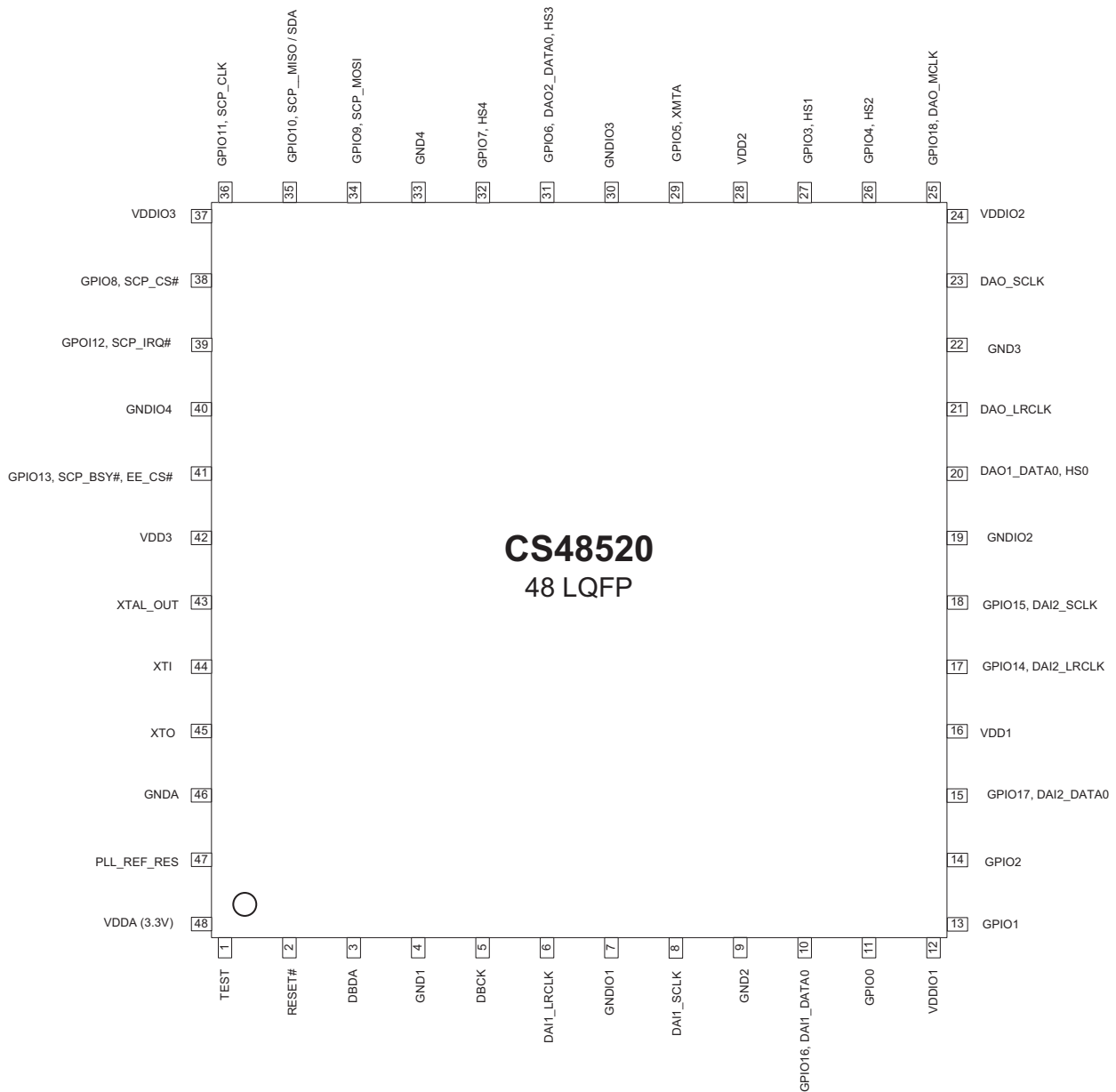

Figure 12. CS48520, 48-Pin LQFP Pinout

8.2 CS48540, 48-pin LQFP Pinout Diagram

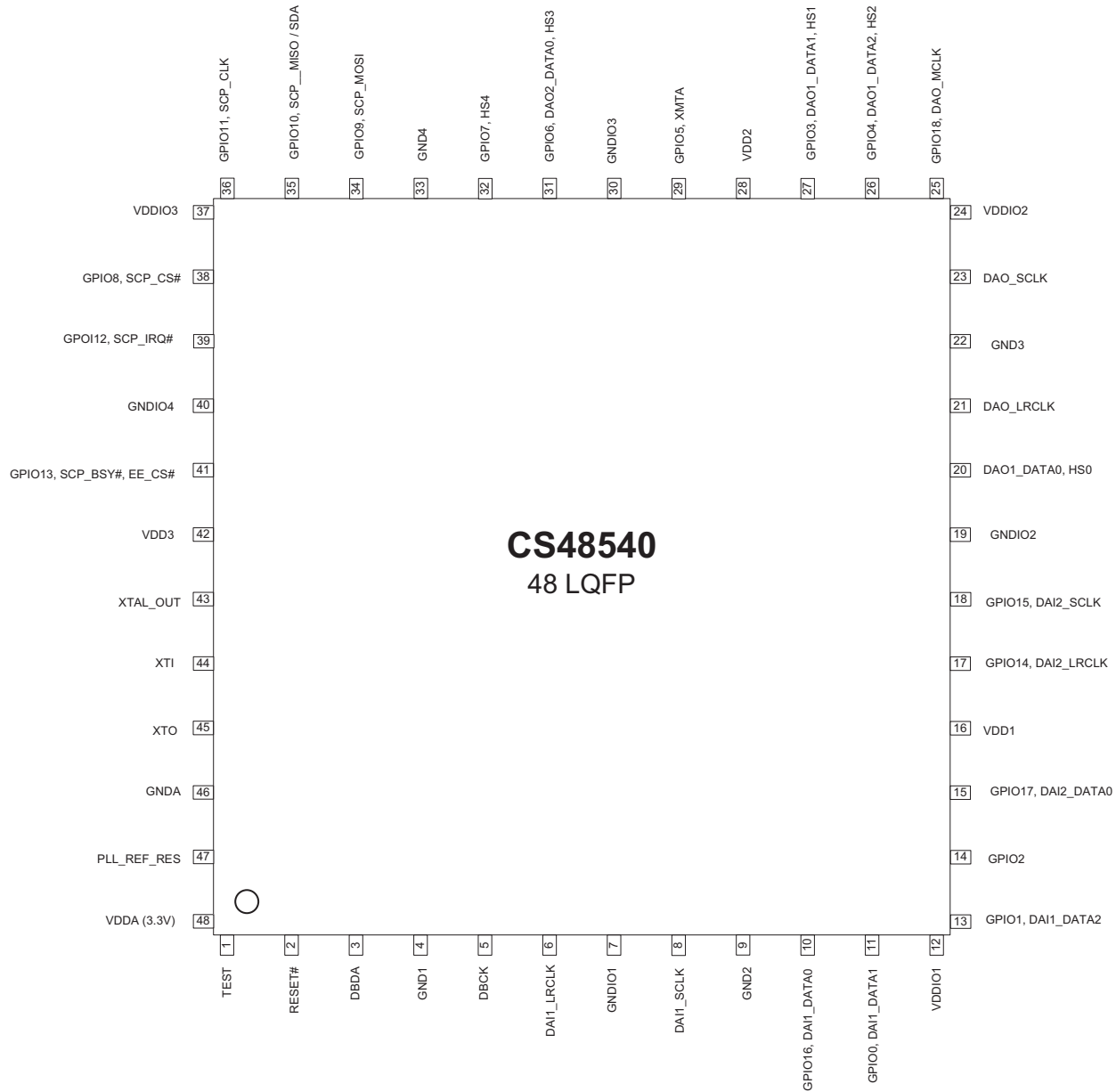

Figure 13. CS48540, 48-Pin LQFP Pinout

8.3 CS48560,48-pin LQFP Pinout Diagram

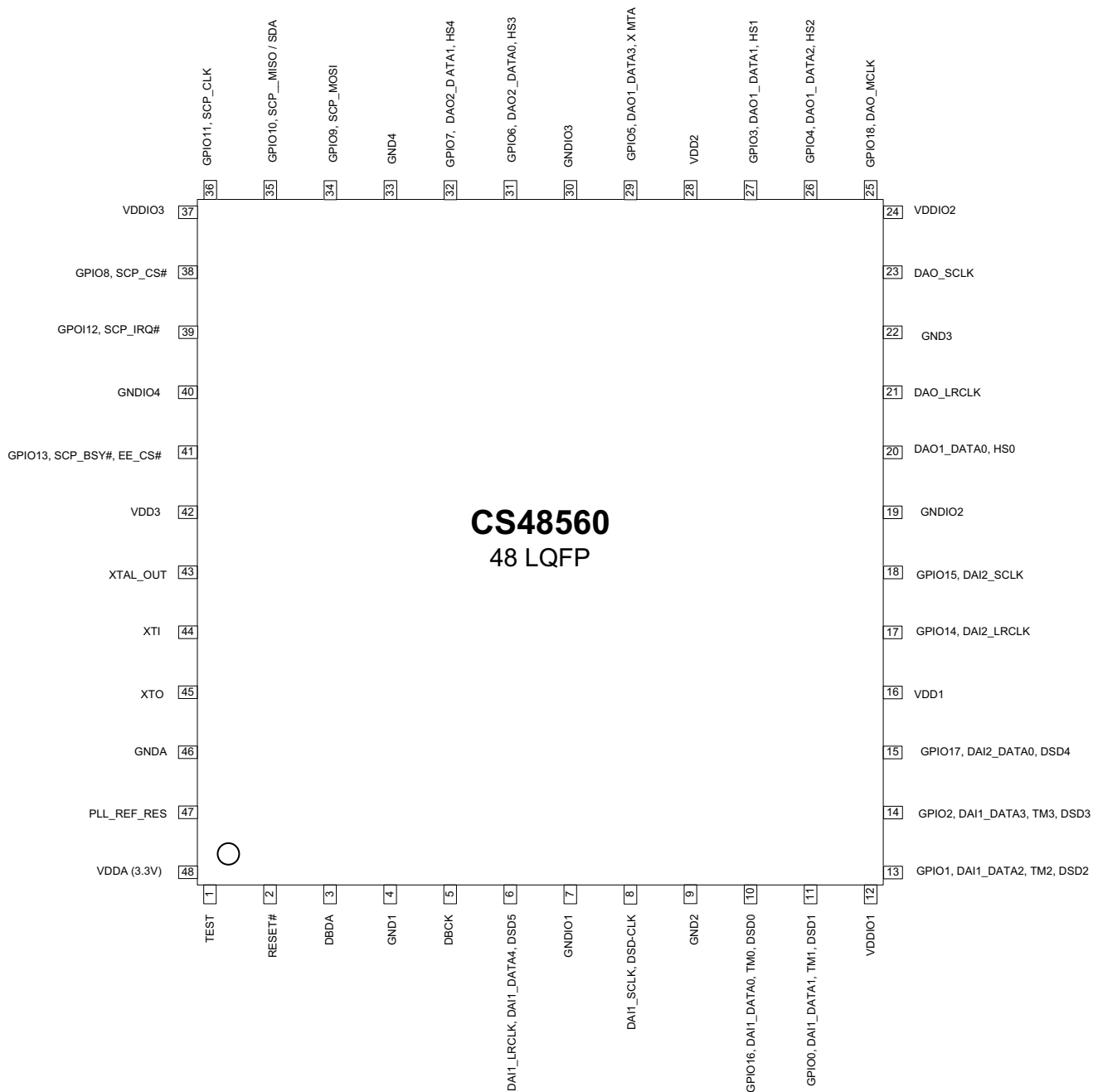

Figure 14. CS48560, 48-Pin LQFP Pinout

FIBER OPTIC RECEIVING MODULE
TORX177L(F,T)

FIBER OPTIC RECEIVING MODULE
 FOR DIGITAL AUDIO INTERFACE

Unit: mm

- For JEITA Standard CP-1212
 (Digital Audio Optical Interface
 for Consumer Equipment).
- A self-tapping hole for easy attachment to
 Audio Equipments panels.
- Shutter System
- RoHS Compatible

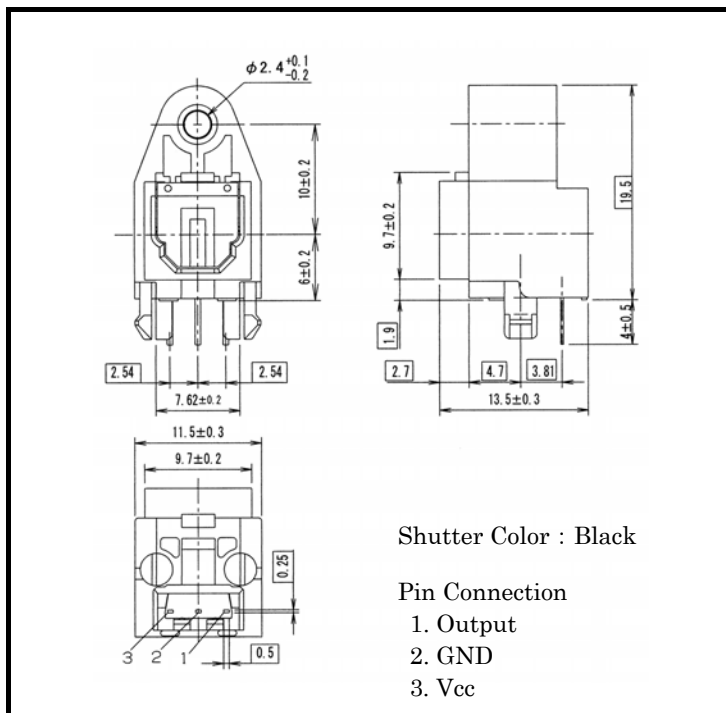

1. Absolute Maximum Ratings (Ta = 25°C)

Characteristics	Symbol	Rating	Unit
Storage Temperature	T _{stg}	-40 to 70	°C
Operating Temperature	T _{opr}	-20 to 70	°C
Supply Voltage	V _{CC}	-0.5 to 6	V
High Level Output Current	I _{OH}	-1	mA
Low Level Output Current	I _{OL}	5	mA
Soldering Temperature	T _{sol}	260 (Note 1)	°C

Note 1: Soldering time ≤ 10 seconds (At a distance of 1 mm from the package).

2. Operating Range

Characteristics	Symbol	Min	Typ.	Max	Unit
Supply Voltage	V _{CC}	4.75	5.0	5.25	V



NJM2068

LOW-NOISE DUAL OPERATIONAL AMPLIFIER

■ GENERAL DESCRIPTION

The NJM2068 is a high performance, low noise dual operational amplifier. This amplifier features popular pin-out, superior noise performance, and superior total harmonic distortion. This amplifier also features guaranteed noise performance with substantially higher gain-bandwidth product and slew rate which far exceeds that of the 4558 type amplifier. The specially designed low noise input transistors allow the NJM2068 to be used in very low noise signal processing applications such as audio preamplifiers and servo error amplifier.

■ FEATURES

- Operating Voltage (±4V ~ ±18V)
- Low Total Harmonic Distortion (0.001% typ.)
- Low Noise Voltage (FLAT+JISA, 0.56 μV typ.)
- High Slew Rate (6V/μs typ.)
- Unity Gain Bandwidth (27MHz @f=10kHz)
- Package Outline DIP8, DMP8, SIP8, SSOP8
- Bipolar Technology

■ PACKAGE OUTLINE

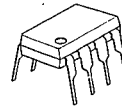

NJM2068D



NJM2068M



NJM2068V

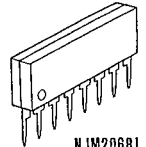

NJM2068L

4

■ PIN CONFIGURATION

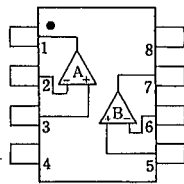

NJM2068D
NJM2068M
NJM2068V

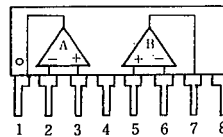

NJM2068L

PIN FUNCTION

1. A OUTPUT
2. A- INPUT
3. A+ INPUT
4. V-
5. B+ INPUT
6. B- INPUT
7. B OUTPUT
8. V+

■ EQUIVALENT CIRCUIT (1/2 Shown)

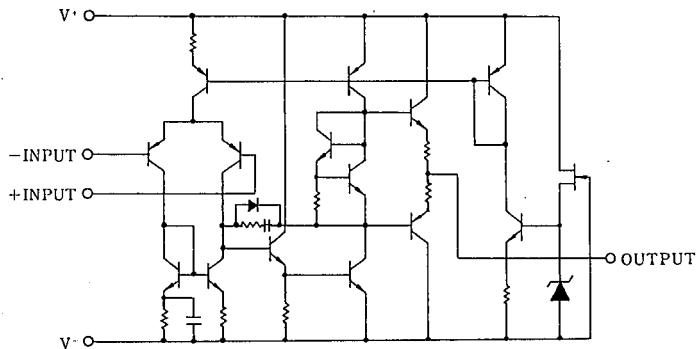

TOSHIBA CMOS DIGITAL INTEGRATED CIRCUIT SILICON MONOLITHIC

TC74HCU04AP, TC74HCU04AF, TC74HCU04AFN

HEX INVERTER

The TC74HCU04A is a high speed CMOS INVERTER fabricated with silicon gate C²MOS technology.

It achieves the high speed operation similar to equivalent LSTTL while maintaining the CMOS low power dissipation.

Since the internal circuit is composed of a single stage inverter, it can be used in analog applications such as crystal oscillators.

All inputs are equipped with protection circuits against static discharge or transient excess voltage.

FEATURES :

- High Speed..... $t_{pd} = 4ns(typ.)$ at $V_{CC} = 5V$
- Low Power Dissipation..... $I_{CC} = 1\mu A(Max.)$ at $T_a = 25^{\circ}C$
- High Noise Immunity..... $V_{NIH} = V_{NIH} = 10\%V_{CC} (Min.)$
- Output Drive Capability..... 10 LSTTL Loads
- Symmetrical Output Impedance... $|I_{OH}| = I_{OL} = 4mA(Min.)$
- Balanced Propagation Delays..... $t_{pLH} \approx t_{pHL}$
- Wide Operating Voltage Range... $V_{CC}(opr.) = 2V \sim 6V$
- Pin and Function Compatible with 74LS04

(Note) The JEDEC SOP (FN) is not available in Japan.

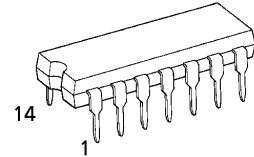

P (DIP14-P-300-2.54)
Weight : 0.96g (Typ.)

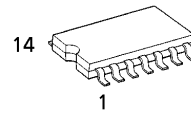

F (SOP14-P-300-1.27)
Weight : 0.18g (Typ.)

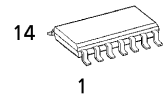

FN (SOL14-P-150-1.27)
Weight : 0.12g (Typ.)

PIN ASSIGNMENT

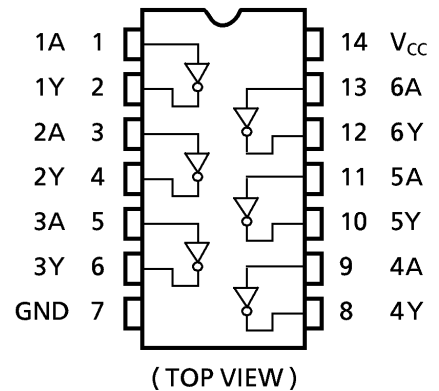

IEC LOGIC SYMBOL

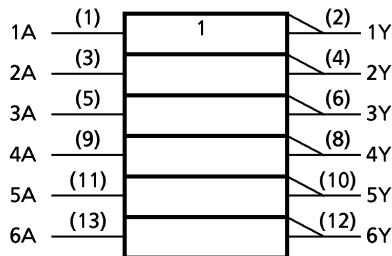

TRUTH TABLE

A	Y
L	H
H	L

961001EBA2

● TOSHIBA is continually working to improve the quality and the reliability of its products. Nevertheless, semiconductor devices in general can malfunction or fail due to their inherent electrical sensitivity and vulnerability to physical stress. It is the responsibility of the buyer, when utilizing TOSHIBA products, to observe standards of safety, and to avoid situations in which a malfunction or failure of a TOSHIBA product could cause loss of human life, bodily injury or damage to property. In developing your designs, please ensure that TOSHIBA products are used within specified operating ranges as set forth in the most recent products specifications. Also, please keep in mind the precautions and conditions set forth in the TOSHIBA Semiconductor Reliability Handbook.



NJM2068

LOW-NOISE DUAL OPERATIONAL AMPLIFIER

■ GENERAL DESCRIPTION

The NJM2068 is a high performance, low noise dual operational amplifier. This amplifier features popular pin-out, superior noise performance, and superior total harmonic distortion. This amplifier also features guaranteed noise performance with substantially higher gain-bandwidth product and slew rate which far exceeds that of the 4558 type amplifier. The specially designed low noise input transistors allow the NJM2068 to be used in very low noise signal processing applications such as audio preamplifiers and servo error amplifier.

■ PACKAGE OUTLINE

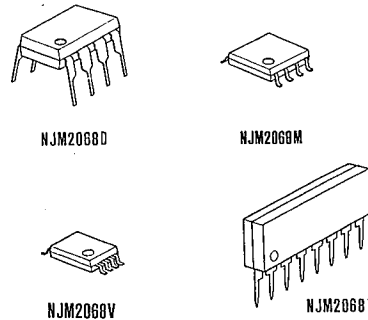

■ FEATURES

- Operating Voltage (±4V ~ ±18V)
- Low Total Harmonic Distortion (0.001% typ.)
- Low Noise Voltage (FLAT+JISA, 0.56 μV typ.)
- High Slew Rate (6V/μs typ.)
- Unity Gain Bandwidth (27MHz @f=10kHz)
- Package Outline DIP8, DMP8, SIP8, SSOP8
- Bipolar Technology

■ PIN CONFIGURATION

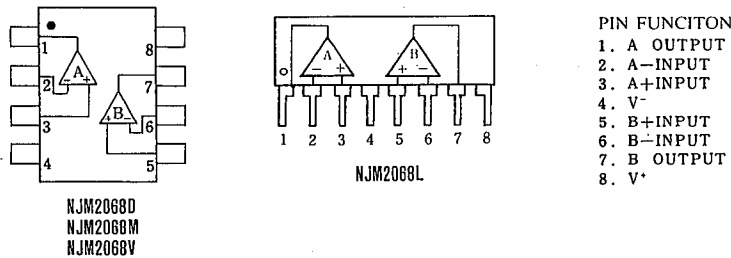

■ EQUIVALENT CIRCUIT (1/2 Shown)

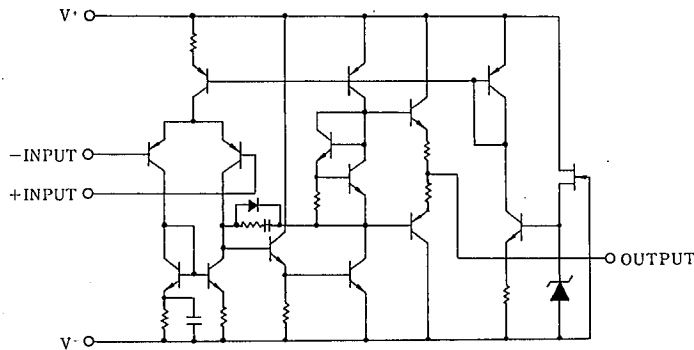

cosmo

High Reliability Photo Coupler

K1010

UL 1577 (File No.E169586) - VDE 0884 / 0860 / 0805 (File No.101347)

Features

1. Current transfer ratio
(CTR:MIN.50% at $I_F=5mA$ $V_{ce}=5V$)
2. High isolation voltage between input and output
(Viso:5000Vrms).
3. Compact dual-in-line package.
4. Available package : DIP/ SMD/ H.

Applications

1. Registers, copiers, automatic vending machines.
2. System appliances, measuring instruments.
3. Computer terminals, programmable controllers.
4. Communications, telephone, etc.
5. Electric home appliances, such as oil fan heaters, Microwave oven, Washer, Refrigerator, Air conditioner, etc.
6. Medical instruments, physical and chemical equipment.
7. Signal transmission between circuits of different potentials and impedances.
8. Facsimile equipment, Audio, Video.
9. Switching power supply, Laser beam printer.

Outside Dimension : Unit (mm)

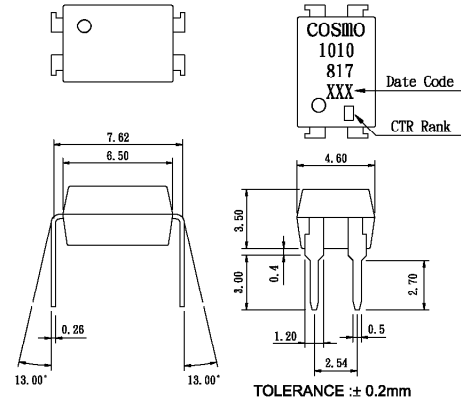

Schematic : Top View

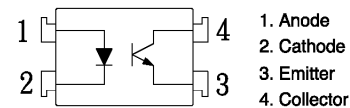

Absolute Maximum Ratings

(Ta=25°C)

Parameter	Symbol	Rating	Unit
Input	Forward current	I_F	50
	Peak forward current	I_{FM}	1
	Reverse voltage	V_R	6
	Power dissipation	P_D	70
Output	Collector-emitter voltage	V_{CEO}	60
	Emitter-collector voltage	V_{ECO}	6
	Collector current	I_C	50
	Collector power dissipation	P_C	150
Total power dissipation	P_{tot}	200	
Isolation voltage 1 minute	V_{iso}	5000	
Operating temperature	T_{opr}	-30 to +100	
Storage temperature	T_{stg}	-55 to +125	
Soldering temperature 10 second	T_{sol}	260	

Electro-optical Characteristics

(Ta=25°C)

Parameter	Symbol	Conditions	MIN.	TYP.	MAX.	Unit
Input	Forward voltage	$I_F=20mA$	—	1.2	1.4	V
	Peak forward voltage	$I_{FM}=0.5A$	—	—	3.0	V
	Reverse current	$V_R=4V$	—	—	10	uA
	Terminal capacitance	$V=0, f=1kHz$	—	30	—	pF
Output	Collector dark current	$V_{CE}=20V$	—	—	0.1	uA
Transfer characteristics	Current transfer ratio	$I_F=5mA, V_{CE}=5V$	50	—	600	%
	Collector-emitter saturation voltage	$I_F=20mA, I_C=1mA$	—	0.1	0.2	V
	Isolation resistance	DC500V	5×10^{10}	10^{11}	—	ohm
	Floating capacitance	$V=0, f=1MHz$	—	0.6	1.0	pF
	Cut-off frequency	$V_{CC}=5V, I_C=2mA, R_L=100ohm$	—	80	—	kHz
	Response time(Rise)	$V_{CE}=2V, I_C=2mA, R_L=100ohm$	—	4	18	us
	Response time(Fall)		—	3	18	us

NJL31H/31V/32H/33H/34H000A

Transmission Distance vs. Carrier Frequency
(Vcc=3.3V, Ta=25°C)

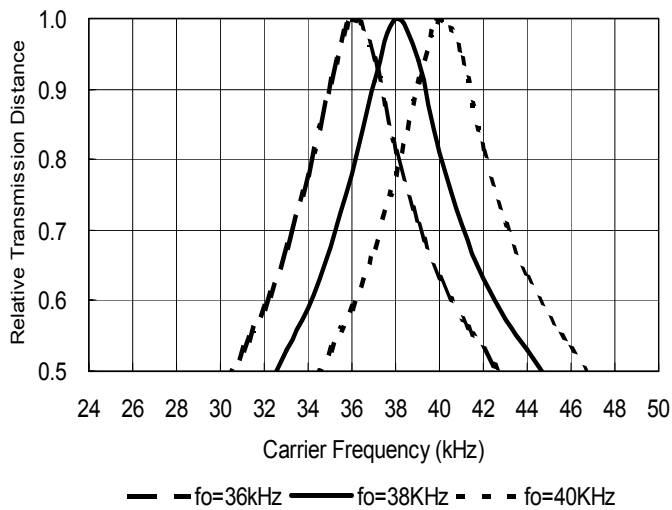

Transmission Distance vs. Temperature
(Vcc=3.3V)

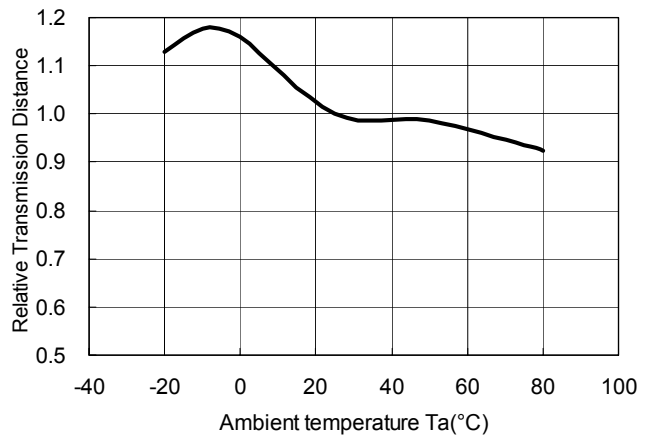

RECOMMENDED APPLICATION CIRCUIT

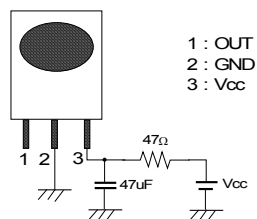

RC Filter should be connected closely between Vcc pin and GND pin.



NJM2068

LOW-NOISE DUAL OPERATIONAL AMPLIFIER

■ GENERAL DESCRIPTION

The NJM2068 is a high performance, low noise dual operational amplifier. This amplifier features popular pin-out, superior noise performance, and superior total harmonic distortion. This amplifier also features guaranteed noise performance with substantially higher gain-bandwidth product and slew rate which far exceeds that of the 4558 type amplifier. The specially designed low noise input transistors allow the NJM2068 to be used in very low noise signal processing applications such as audio preamplifiers and servo error amplifier.

■ FEATURES

- Operating Voltage (±4V ~ ±18V)
- Low Total Harmonic Distortion (0.001% typ.)
- Low Noise Voltage (FLAT+JISA, 0.56 μV typ.)
- High Slew Rate (6V/μs typ.)
- Unity Gain Bandwidth (27MHz @f=10kHz)
- Package Outline DIP8, DMP8, SIP8, SSOP8
- Bipolar Technology

■ PACKAGE OUTLINE

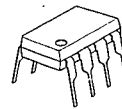

NJM2068D



NJM2068M



NJM2068V

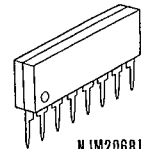

NJM2068L

■ PIN CONFIGURATION

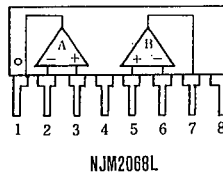
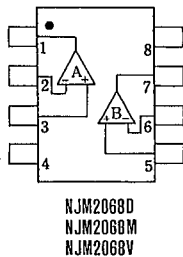

PIN FUNCTION

1. A OUTPUT
2. A-INPUT
3. A+INPUT
4. V-
5. B+INPUT
6. B-INPUT
7. B OUTPUT
8. V+

■ EQUIVALENT CIRCUIT (1/2 Shown)

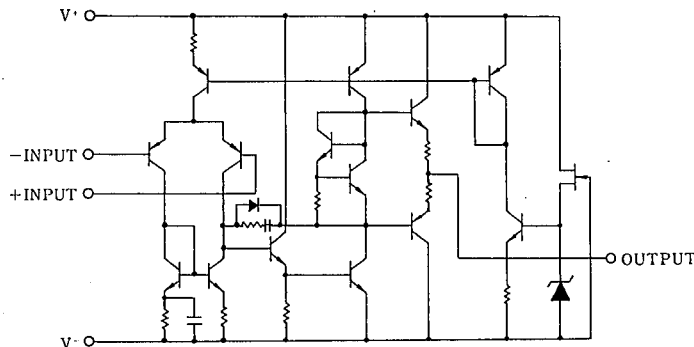



NJM2296

5-INPUT 3-OUTPUT VIDEO SWITCH

■ GENERAL DESCRIPTION

The NJM2296 is a 5-input 3-output video switch. Its switches select one from five signals received from VCR, TV, Video Disk Player and others. This IC is designed for audio items, such as AV amplifier and receivers, and others.

■ PACKAGE OUTLINE

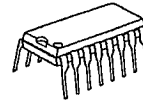

NJM2296D

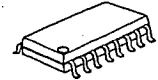

NJM2296M

■ FEATURES

- 5-input 3-output
- Operating Voltage ($\pm 4.0V \sim \pm 6.5V$)
- Crosstalk ($-65dB$ typ.)
- Bipolar Technology
- Package Outline DIP16, DMP16

■ PIN CONFIGURATION AND BLOCK DIAGRAM

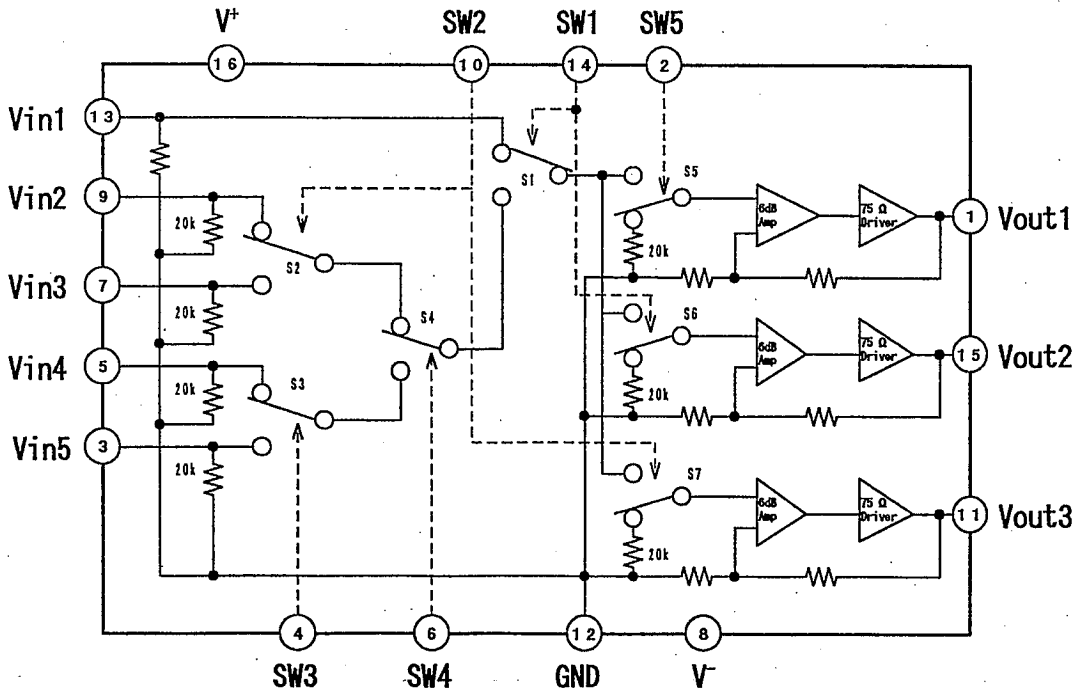

5

Features

- **Low-voltage and Standard-voltage Operation**
 - 2.7 (V_{CC} = 2.7V to 5.5V)
 - 1.8 (V_{CC} = 1.8V to 5.5V)
- **Internally Organized 128 x 8 (1K), 256 x 8 (2K), 512 x 8 (4K), 1024 x 8 (8K) or 2048 x 8 (16K)**
- **Two-wire Serial Interface**
- **Schmitt Trigger, Filtered Inputs for Noise Suppression**
- **Bidirectional Data Transfer Protocol**
- **100 kHz (1.8V) and 400 kHz (2.7V, 5V) Compatibility**
- **Write Protect Pin for Hardware Data Protection**
- **8-byte Page (1K, 2K), 16-byte Page (4K, 8K, 16K) Write Modes**
- **Partial Page Writes Allowed**
- **Self-timed Write Cycle (5 ms max)**
- **High-reliability**
 - Endurance: 1 Million Write Cycles
 - Data Retention: 100 Years
- **Automotive Grade and Lead-free/Halogen-free Devices Available**
- **8-lead PDIP, 8-lead JEDEC SOIC, 8-lead MAP, 5-lead SOT23, 8-lead TSSOP and 8-ball dBGAA2 Packages**
- **Die Sales: Wafer Form, Waffle Pack and Bumped Wafers**

Description

The AT24C01A/02/04/08A/16A provides 1024/2048/4096/8192/16384 bits of serial electrically erasable and programmable read-only memory (EEPROM) organized as 128/256/512/1024/2048 words of 8 bits each. The device is optimized for use in many industrial and commercial applications where low-power and low-voltage operation are essential. The AT24C01A/02/04/08A/16A is available in space-saving 8-lead PDIP, 8-lead JEDEC SOIC, 8-lead MAP, 5-lead SOT23 (AT24C01A/AT24C02/AT24C04), 8-lead TSSOP, and 8-ball dBGAA2 packages and is accessed via a Two-wire serial interface. In addition, the entire family is available in 2.7V (2.7V to 5.5V) and 1.8V (1.8V to 5.5V) versions.

Table 1. Pin Configuration

Pin Name	Function
A0 - A2	Address Inputs
SDA	Serial Data
SCL	Serial Clock Input
WP	Write Protect
NC	No Connect
GND	Ground
VCC	Power Supply

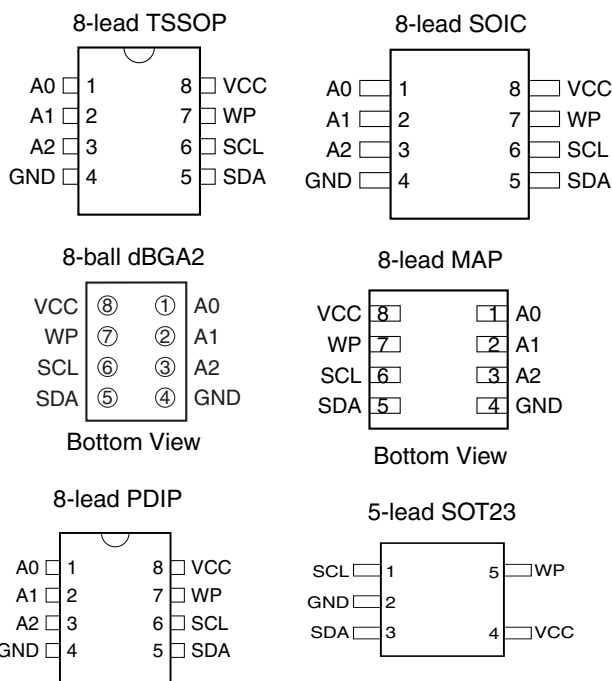

Two-wire Serial EEPROM

- 1K (128 x 8)
- 2K (256 x 8)
- 4K (512 x 8)
- 8K (1024 x 8)
- 16K (2048 x 8)

- AT24C01A
- AT24C02
- AT24C04
- AT24C08A
- AT24C16A





NJM2068

LOW-NOISE DUAL OPERATIONAL AMPLIFIER

■ GENERAL DESCRIPTION

The NJM2068 is a high performance, low noise dual operational amplifier. This amplifier features popular pin-out, superior noise performance, and superior total harmonic distortion. This amplifier also features guaranteed noise performance with substantially higher gain-bandwidth product and slew rate which far exceeds that of the 4558 type amplifier. The specially designed low noise input transistors allow the NJM2068 to be used in very low noise signal processing applications such as audio preamplifiers and servo error amplifier.

■ FEATURES

- Operating Voltage (±4V ~ ±18V)
- Low Total Harmonic Distortion (0.001% typ.)
- Low Noise Voltage (FLAT+JISA, 0.56 μV typ.)
- High Slew Rate (6V/μs typ.)
- Unity Gain Bandwidth (27MHz @f=10kHz)
- Package Outline DIP8, DMP8, SIP8, SSOP8
- Bipolar Technology

■ PACKAGE OUTLINE

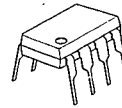

NJM2068D



NJM2068M



NJM2068V

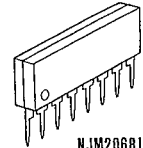

NJM2068L

■ PIN CONFIGURATION

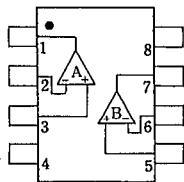

NJM2068D
NJM2068M
NJM2068V

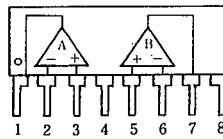

NJM2068L

PIN FUNCTION

1. A OUTPUT
2. A-INPUT
3. A+INPUT
4. V-
5. B+INPUT
6. B-INPUT
7. B OUTPUT
8. V+

■ EQUIVALENT CIRCUIT (1/2 Shown)

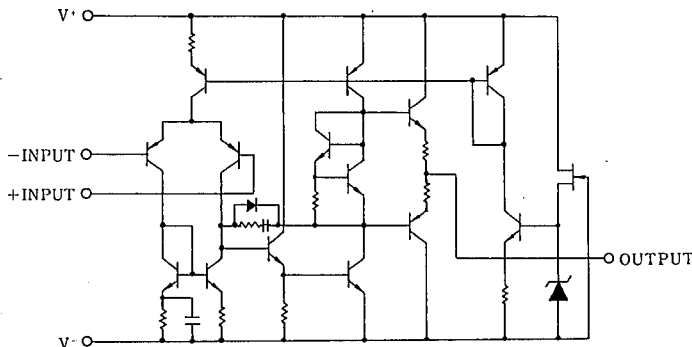

ULTRA-SMALL PACKAGE HIGH-PRECISION VOLTAGE DETECTOR WITH DELAY CIRCUIT (INTERNAL DELAY TIME SETTING)

S-801 Series

Rev.3.3_00

■ Pin Configurations

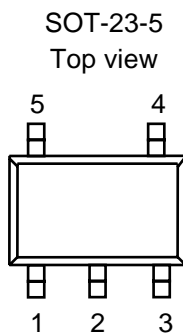

Figure 3

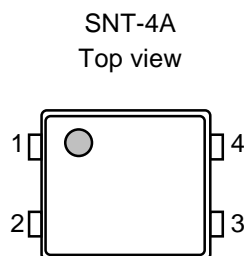

Figure 4

Table 3

Pin No.	Pin name	Pin description
1	DS ^{*1}	ON/OFF switch for delay time
2	VSS	GND pin
3	NC ^{*2}	No connection
4	OUT	Voltage detection output pin
5	VDD	Voltage input pin

*1. Refer to "2. Delay Circuit" in "■ Operation" for operation.

*2. The NC pin is electrically open.

The NC pin can be connected to VDD or VSS.

Table 4

Pin No.	Pin name	Pin description
1	VSS	GND pin
2	DS ^{*1}	ON/OFF switch for delay time
3	VDD	Voltage input pin
4	OUT	Voltage detection output pin

*1. Refer to "2. Delay Circuit" in "■ Operation" for operation.

Radio Data System (RDS) demodulator

SAA6579

PINNING

SYMBOL	PIN	DESCRIPTION
QUAL	1	quality indication output
RDDA	2	RDS data output
V _{ref}	3	reference voltage output (0.5V _{DDA})
MUX	4	multiplex signal input
V _{DDA}	5	+5 V supply voltage for analog part
V _{SSA}	6	ground for analog part (0 V)
CIN	7	subcarrier input to comparator
SCOUT	8	subcarrier output of reconstruction filter
MODE	9	oscillator mode/test control input
TEST	10	test enable input
V _{SSD}	11	ground for digital part (0 V)
V _{DDD}	12	+5 V supply voltage for digital part
OSCI	13	oscillator input
OSCO	14	oscillator output
T57	15	57 kHz clock signal output
RDCL	16	RDS clock output

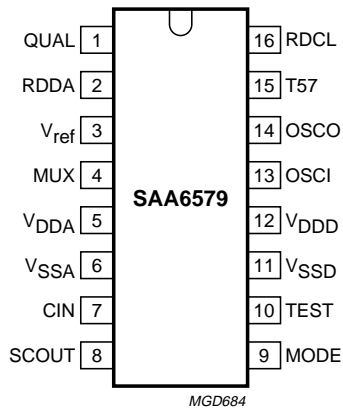

Fig.2 Pin configuration.

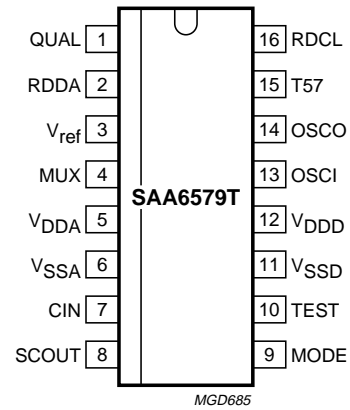

Fig.3 Pin configuration.

TOSHIBA CMOS DIGITAL INTEGRATED CIRCUIT SILICON MONOLITHIC

TC74VHC08F, TC74VHC08FN, TC74VHC08FT

QUAD 2-INPUT AND GATE

The TC74VHC08 is an advanced high speed CMOS 2-INPUT AND GATE fabricated with silicon gate C²MOS technology. It achieves the high speed operation similar to equivalent Bipolar Schottky TTL while maintaining the CMOS low power dissipation.

The internal circuit is composed of 4 stages including buffer output, which provide high noise immunity and stable output. An input protection circuit ensures that 0 to 5.5V can be applied to the input pins without regard to the supply voltage. This device can be used to interface from 5V to 3V systems and two supply systems such as battery back up. This circuit prevents device destruction due to mismatched supply and input voltages.

FEATURES :

- High Speed..... $t_{pd} = 4.3ns$ (typ.) at $V_{CC} = 5V$
- Low Power Dissipation..... $I_{CC} = 2\mu A$ (Max.) at $T_a = 25^{\circ}C$
- High Noise Immunity..... $V_{NIH} = V_{NIL} = 28\% V_{CC}$ (Min.)
- Power Down Protection is provided on all inputs.
- Balanced Propagation Delays..... $t_{pLH} \approx t_{pHL}$
- Wide Operating Voltage Range..... V_{CC} (opr) = 2V ~ 5.5V
- Low Noise $V_{OLP} = 0.8V$ (Max.)
- Pin and Function Compatible with 74ALS08

(Note) The JEDEC SOP (FN) is not available in Japan.

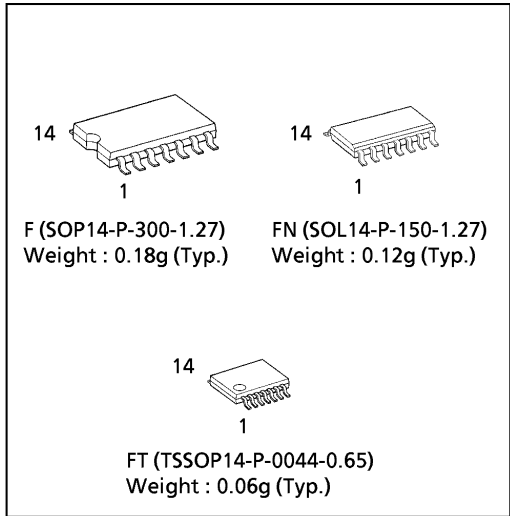

PIN ASSIGNMENT

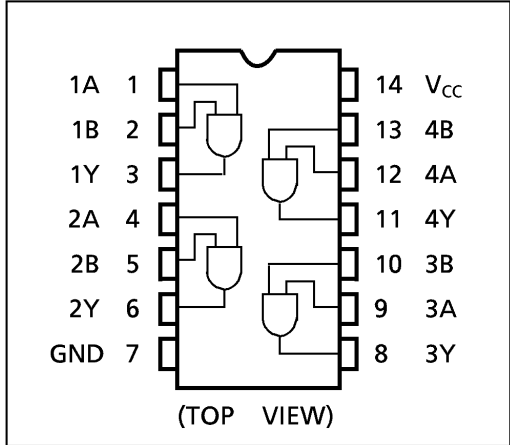

IEC LOGIC SYMBOL

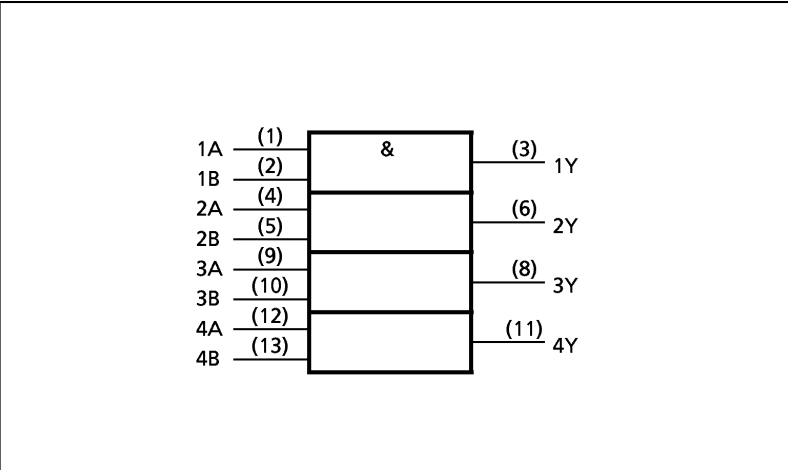

TRUTH TABLE

A	B	Y
L	L	L
L	H	L
H	L	L
H	H	H

980910EBA2

● TOSHIBA is continually working to improve the quality and the reliability of its products. Nevertheless, semiconductor devices in general can malfunction or fail due to their inherent electrical sensitivity and vulnerability to physical stress. It is the responsibility of the buyer, when utilizing TOSHIBA products, to observe standards of safety, and to avoid situations in which a malfunction or failure of a TOSHIBA product could cause loss of human life, bodily injury or damage to property. In developing your designs, please ensure that TOSHIBA products are used within specified operating ranges as set forth in the most recent products specifications. Also, please keep in mind the precautions and conditions set forth in the TOSHIBA Semiconductor Reliability Handbook.

TOSHIBA CMOS DIGITAL INTEGRATED CIRCUIT SILICON MONOLITHIC

TC74VHCT08AF, TC74VHCT08AFN, TC74VHCT08AFT

QUAD 2-INPUT AND GATE

The TC74VHCT08A is an advanced high speed CMOS 2-INPUT AND GATE fabricated with silicon gate C²MOS technology. It achieves the high speed operation similar to equivalent Bipolar Schottky TTL while maintaining the CMOS low power dissipation. The input voltage are compatible with TTL output voltage. This device may be used as a level converter for interfacing 3.3V to 5V system. Input protection and output circuit ensure that 0 to 5.5V can be applied to the input and output*1 pins without regard to the supply voltage. These structure prevents device destruction due to mismatched supply and input/output voltages such as battery back up, hot board insertion, etc.
*1: V_{cc}=0V

FEATURES :

- High Speed.....t_{pd} = 5.0ns(typ.) at V_{CC} = 5V
- Low Power Dissipation.....I_{CC} = 2μA(Max.) at Ta = 25°C
- Compatible with TTL outputs....V_{IL} = 0.8V (Max.)
V_{IH} = 2.0V (Min.)
- Power Down Protection is provided on all inputs and outputs.
- Balanced Propagation Delays.....t_{pLH} ≈ t_{pHL}
- Low NoiseV_{OLP} = 0.8V (Max.)
- Pin and Function Compatible with the 74 series (74AC / HC / F / ALS / LS etc.) 08 type.

(Note) The JEDEC SOP (FN) is not available in Japan.

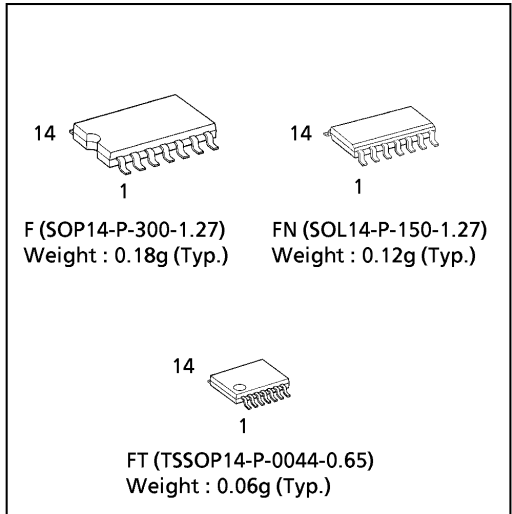

PIN ASSIGNMENT

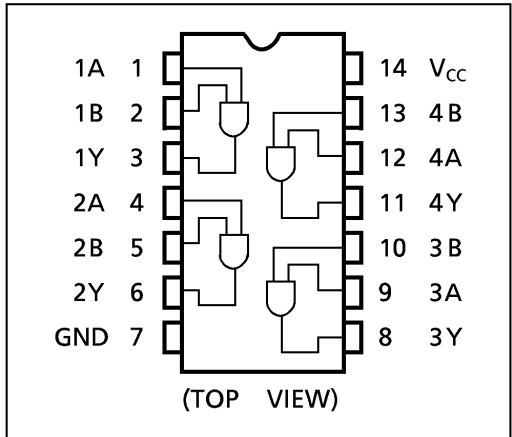

IEC LOGIC SYMBOL

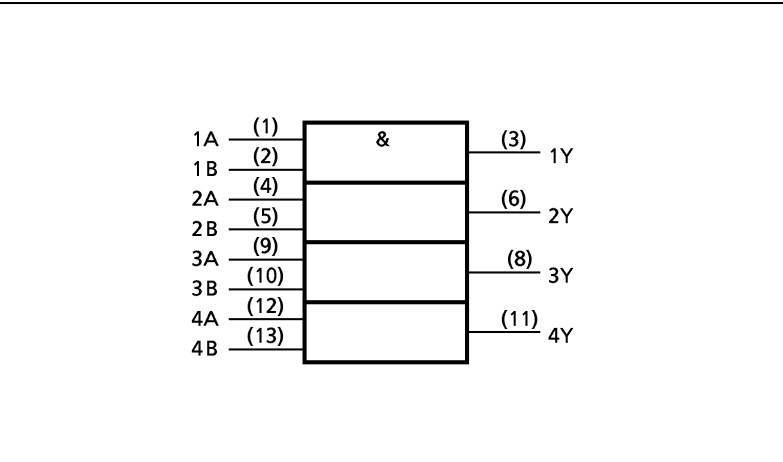

TRUTH TABLE

A	B	Y
L	L	L
L	H	L
H	L	L
H	H	H

961001EBA2

● TOSHIBA is continually working to improve the quality and the reliability of its products. Nevertheless, semiconductor devices in general can malfunction or fail due to their inherent electrical sensitivity and vulnerability to physical stress. It is the responsibility of the buyer, when utilizing TOSHIBA products, to observe standards of safety, and to avoid situations in which a malfunction or failure of a TOSHIBA product could cause loss of human life, bodily injury or damage to property. In developing your designs, please ensure that TOSHIBA products are used within specified operating ranges as set forth in the most recent products specifications. Also, please keep in mind the precautions and conditions set forth in the TOSHIBA Semiconductor Reliability Handbook.

TOSHIBA

TC9162~64AN/AF

PIN CONNECTION (TOP VIEW)

TC9162AN / AF

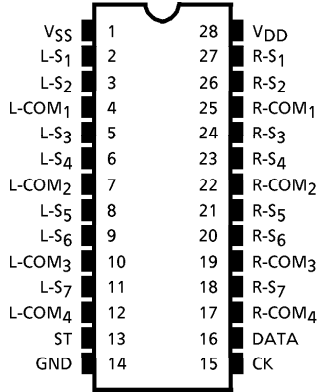

TC9163AN / AF

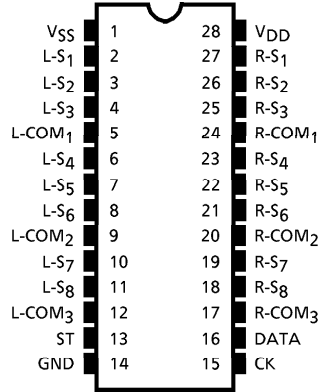

TC9164AN / AF

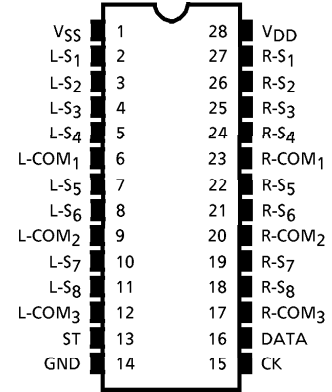

BLOCK DIAGRAM

TC9162AN / AF

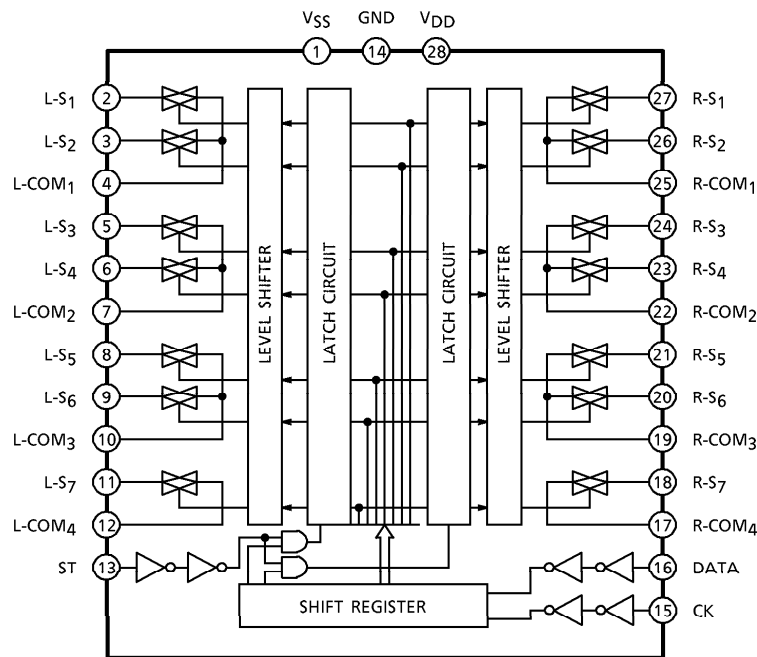

PIN CONNECTIONS

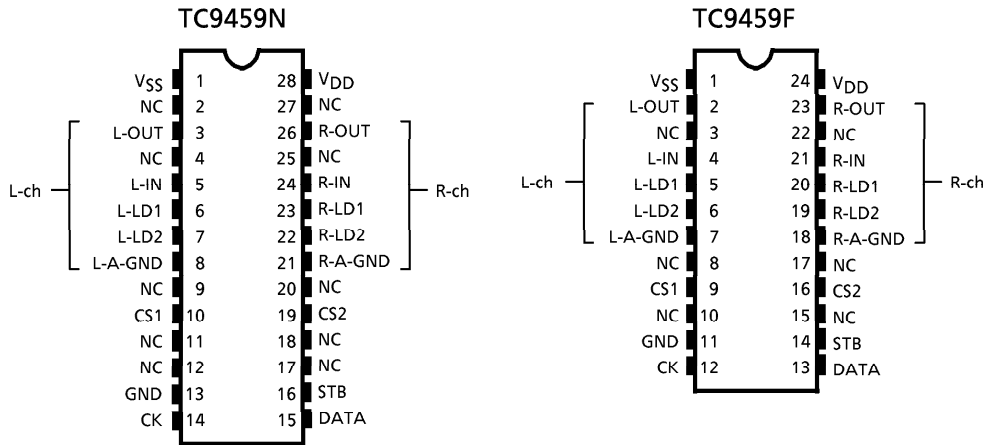

BLOCK DIAGRAM (TC9459N)

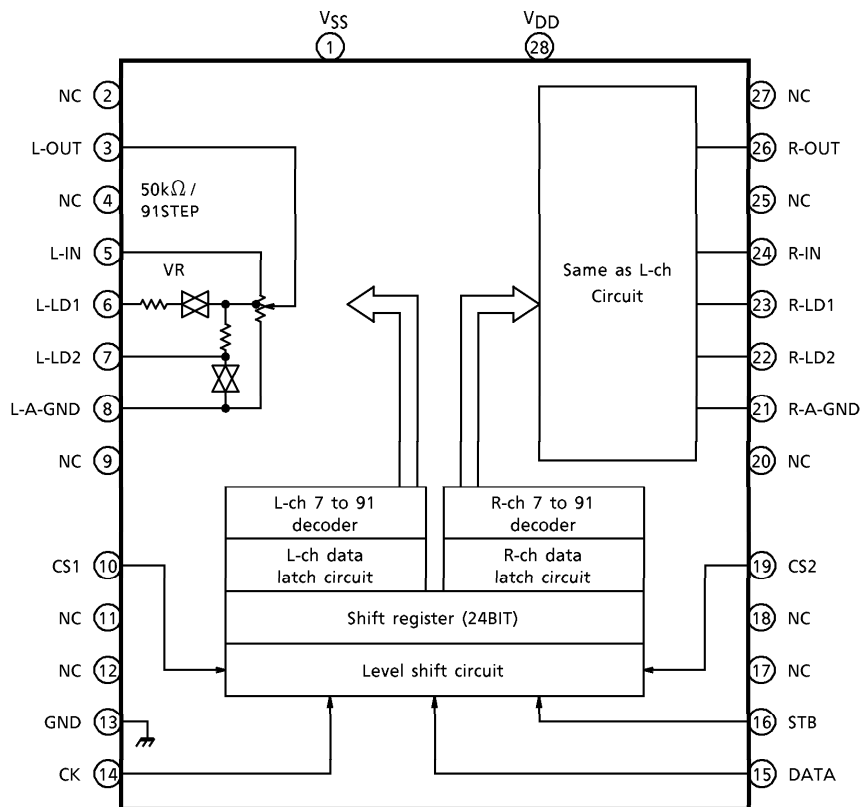

Darlington

2SB1570

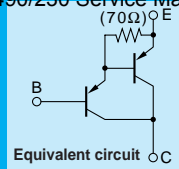

Silicon PNP Epitaxial Planar Transistor (Complement to type 2SD2401)

Application : Audio, Series Regulator and General Purpose

Absolute maximum ratings (Ta=25°C)

Symbol	2SB1570	Unit
V _{CB0}	-160	V
V _{CEO}	-150	V
V _{EBO}	-5	V
I _C	-12	A
I _B	-1	A
P _C	150(T _C =25°C)	W
T _J	150	°C
T _{stg}	-55 to +150	°C

Electrical Characteristics (Ta=25°C)

Symbol	Conditions	2SB1570	Unit
I _{CB0}	V _{CB} =-160V	-100max	μA
I _{EBO}	V _{EB} =-5V	-100max	μA
V(BR)CEO	I _C =-30mA	-150min	V
h _{FE}	V _{CE} =-4V, I _C =-7A	5000min*	
V _{CE(sat)}	I _C =-7A, I _B =-7mA	-2.5max	V
V _{BE(sat)}	I _C =-7A, I _E =-7mA	-3.0max	V
f _r	V _{CE} =-12V, I _E =2A	50typ	MHz
COB	V _{CB} =-10V, f=1MHz	230typ	pF

*h_{FE} Rank O(5000to12000), P(6500to20000), Y(15000to30000)

Typical Switching Characteristics (Common Emitter)

V _{CC} (V)	R _L (Ω)	I _C (A)	V _{BB1} (V)	V _{BB2} (V)	I _{B1} (mA)	I _{B2} (mA)	t _{on} (μs)	t _{stg} (μs)	t _f (μs)
-70	10	-7	-10	5	-7	7	0.8typ	3.0typ	1.2typ

External Dimensions MT-200

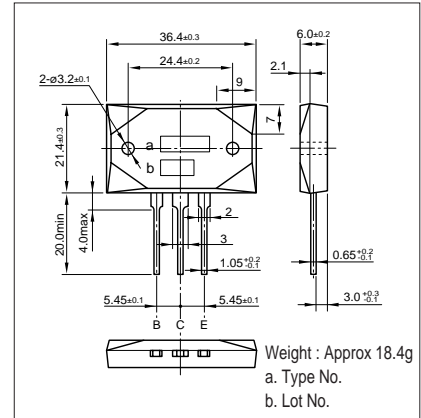

I_C-V_{CE} Characteristics (Typical)

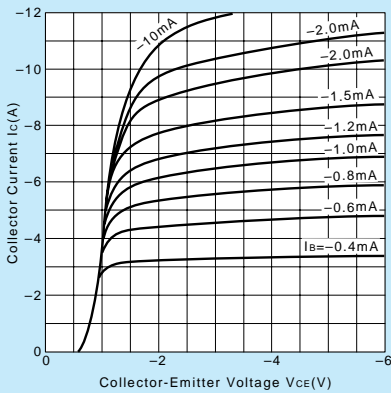

V_{CE(sat)}-I_B Characteristics (Typical)

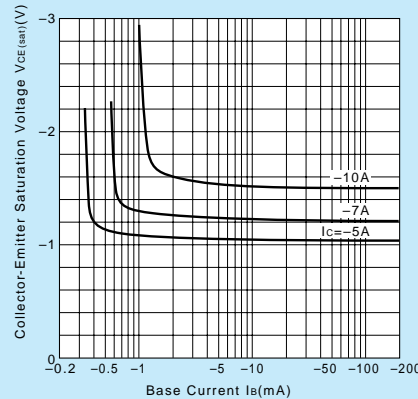

I_C-V_{BE} Temperature Characteristics (Typical)

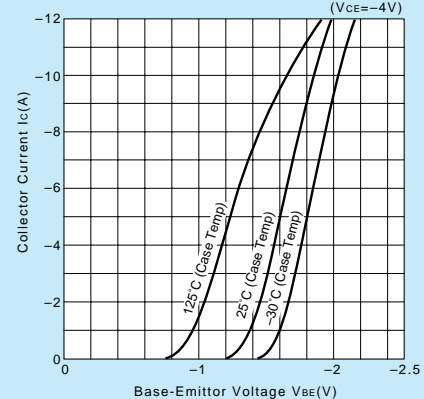

h_{FE}-I_C Characteristics (Typical)

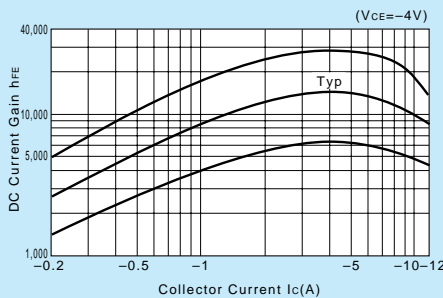

h_{FE}-I_C Temperature Characteristics (Typical)

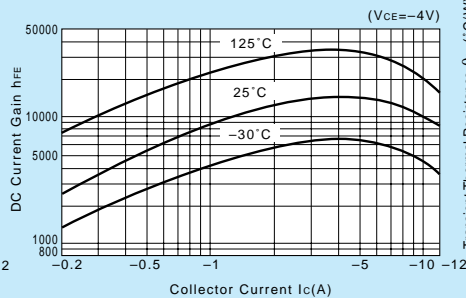

θ_{j-a}-t Characteristics

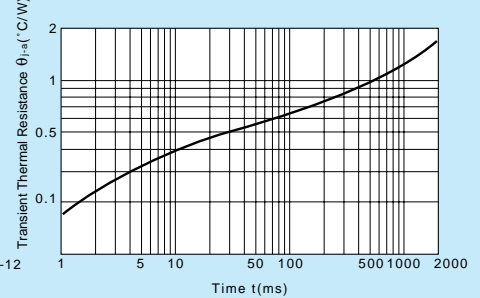

f_T-I_E Characteristics (Typical)

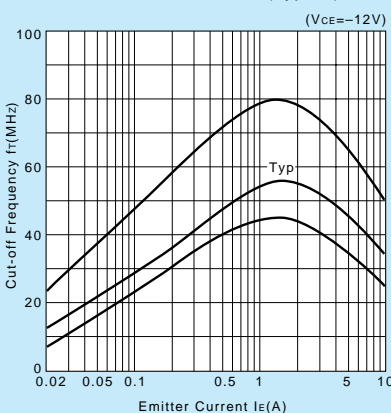

Safe Operating Area (Single Pulse)

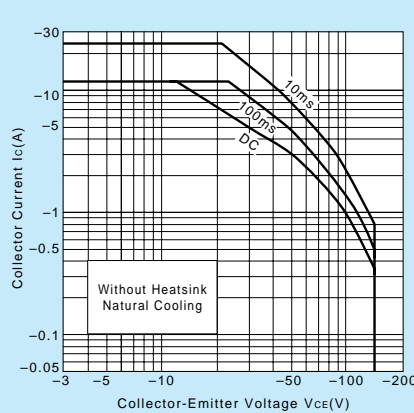

P_C-T_a Derating

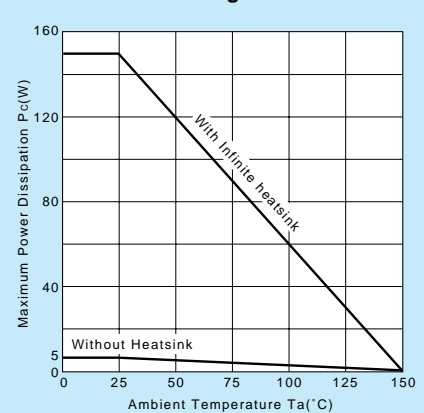

Darlington 2SD2401

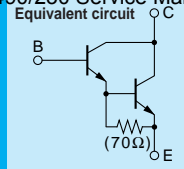

Silicon NPN Triple Diffused Planar Transistor (Complement to type 2SB1570)

Application : Audio, Series Regulator and General Purpose

Absolute maximum ratings (Ta=25°C)

Symbol	2SD2401	Unit
V _{CB0}	160	V
V _{CE0}	150	V
V _{EB0}	5	V
I _C	12	A
I _B	1	A
P _C	150(T _C =25°C)	W
T _J	150	°C
T _{stg}	-55 to +150	°C

Electrical Characteristics (Ta=25°C)

Symbol	Conditions	2SD2401	Unit
I _{CB0}	V _{CB} =160V	100max	μA
I _{EB0}	V _{EB} =5V	100max	μA
V _{(BR)CEO}	I _C =30mA	150min	V
h _{FE}	V _{CE} =4V, I _C =7A	5000min*	
V _{CE(sat)}	I _C =7A, I _B =7mA	2.5max	V
V _{BE(sat)}	I _C =7A, I _B =7mA	3.0max	V
f _T	V _{CE} =12V, I _E =-2A	55typ	MHz
COB	V _{CB} =10V, f=1MHz	95typ	pF

*h_{FE} Rank O(5000 to 12000), P(6500 to 20000), Y(15000 to 30000)

Typical Switching Characteristics (Common Emitter)

V _{CC} (V)	R _L (Ω)	I _C (A)	V _{BB1} (V)	V _{BB2} (V)	I _{B1} (mA)	I _{B2} (mA)	t _{on} (μs)	t _{stg} (μs)	t _f (μs)
70	10	7	10	-5	7	-7	0.5typ	10.0typ	1.1typ

External Dimensions MT-200

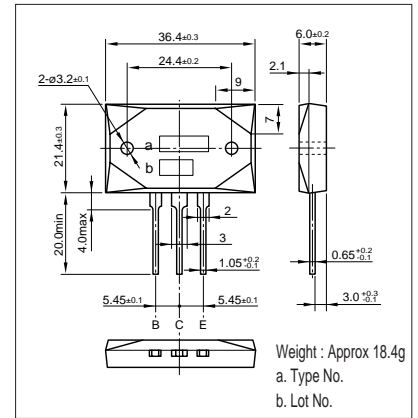

I_C-V_{CE} Characteristics (Typical)

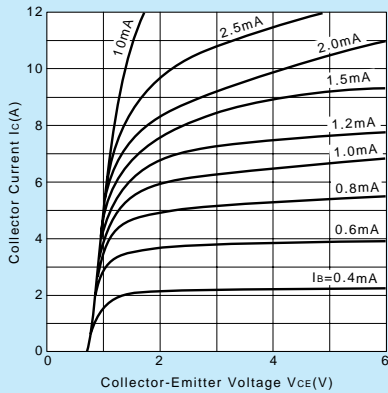

V_{CE(sat)}-I_B Characteristics (Typical)

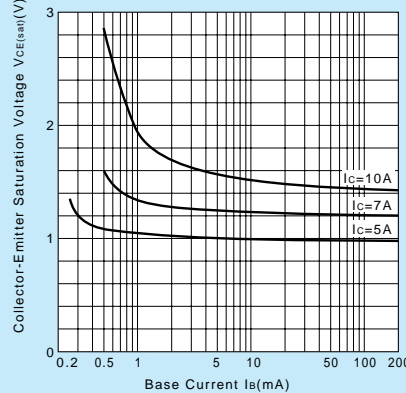

I_C-V_{BE} Temperature Characteristics (Typical)

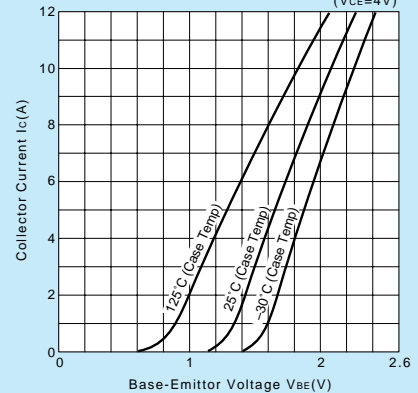

h_{FE}-I_C Characteristics (Typical)

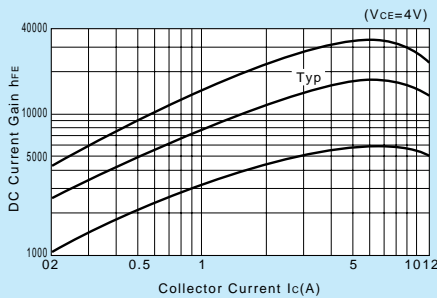

h_{FE}-I_C Temperature Characteristics (Typical)

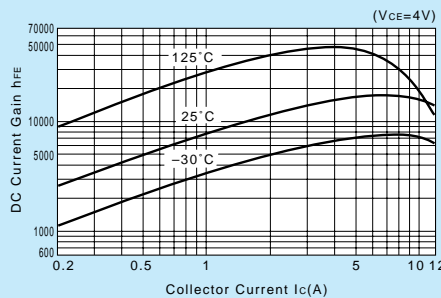

θ_{JA}-t Characteristics

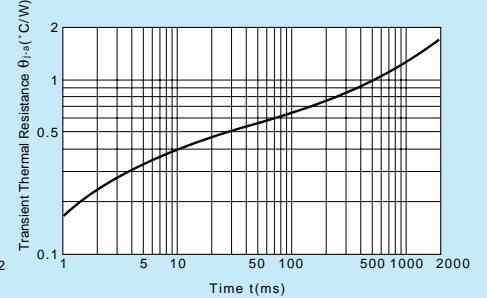

f_T-I_E Characteristics (Typical)

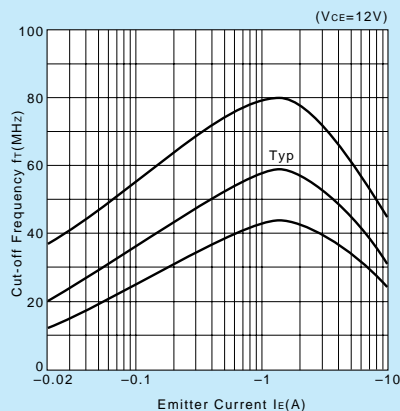

Safe Operating Area (Single Pulse)

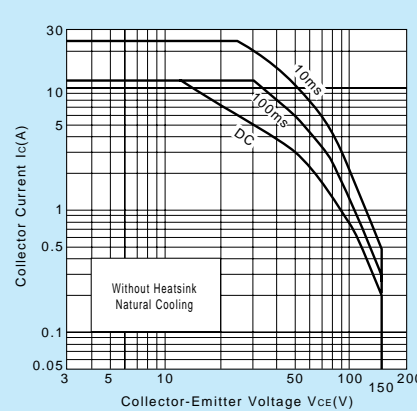

P_C-T_a Derating

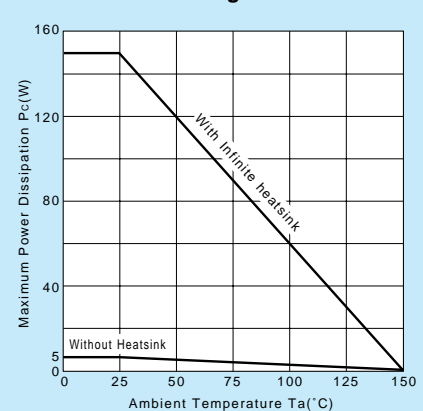

ULTRA-SMALL PACKAGE HIGH-PRECISION VOLTAGE DETECTOR
S-808xxC Series

Rev.3.2_00

■ **Pin Configurations**

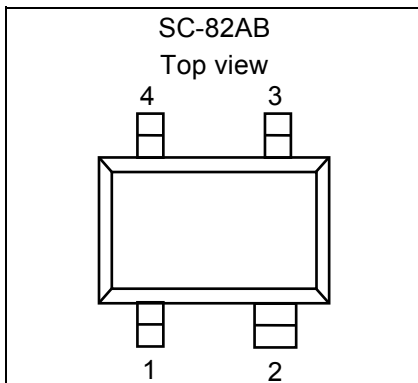

Figure 4

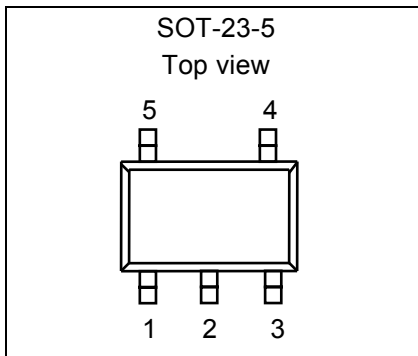

Figure 5

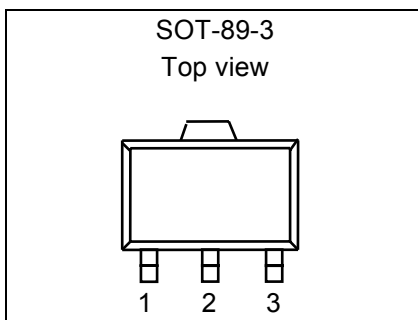

Figure 6

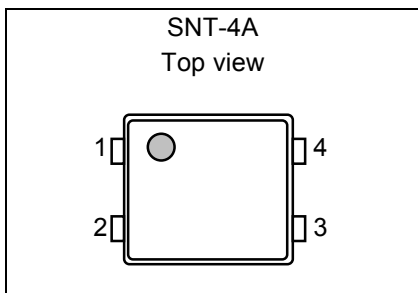

Figure 7

Table 7

Pin No.	Pin name	Pin description
1	OUT	Voltage detection output pin
2	VDD	Voltage input pin
3	NC*1	No connection
4	VSS	GND pin

*1. The NC pin is electrically open.
 The NC pin can be connected to VDD or VSS.

Table 8

Pin No.	Pin name	Pin description
1	OUT	Voltage detection output pin
2	VDD	Voltage input pin
3	VSS	GND pin
4	NC*1	No connection
5	NC*1	No connection

*1. The NC pin is electrically open.
 The NC pin can be connected to VDD or VSS.

Table 9

Pin No.	Pin name	Pin description
1	OUT	Voltage detection output pin
2	VDD	Voltage input pin
3	VSS	GND pin

Table10

Pin No.	Pin name	Pin description
1	OUT	Voltage detection output pin
2	VSS	GND pin
3	NC*1	No connection
4	VDD	Voltage input pin

*1. The NC pin is electrically open.
 The NC pin can be connected to VDD or VSS.

ULTRA-SMALL PACKAGE HIGH-PRECISION VOLTAGE DETECTOR

S-808xxC Series

Rev.3.2_00

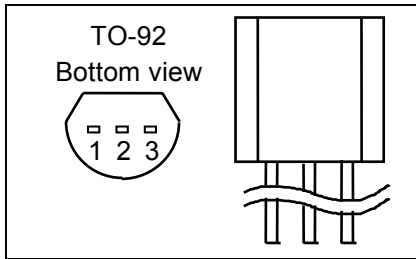

Figure 8

Table 11

Pin No.	Pin name	Pin description
1	OUT	Voltage detection output pin
2	VDD	Voltage input pin
3	VSS	GND pin

■ Absolute Maximum Ratings

1. Detection Voltage Typ. 1.4 V or Less Products

Table 12

(Ta=25°C unless otherwise specified)

Item	Symbol	Absolute maximum ratings	Unit
Power supply voltage	$V_{DD}-V_{SS}$	7	V
Output voltage	Nch open-drain output products CMOS output products	V_{OUT}	$V_{SS}-0.3$ to $V_{SS}+7$
			$V_{SS}-0.3$ to $V_{DD}+0.3$
Output current	I_{OUT}	50	mA
Power dissipation	P_D	SC-82AB	150
		SNT-4A	140
Operating ambient temperature	T_{opr}	-40 to +85	°C
Storage temperature	T_{stg}	-40 to +125	

Caution The absolute maximum ratings are rated values exceeding which the product could suffer physical damage. These values must therefore not be exceeded under any conditions.

2. Detection Voltage Typ. 1.5 V or More Products

Table 13

(Ta=25°C unless otherwise specified)

Item	Symbol	Absolute maximum ratings	Unit
Power supply voltage	$V_{DD}-V_{SS}$	12	V
Output voltage	Nch open-drain output products CMOS output products	V_{OUT}	$V_{SS}-0.3$ to $V_{SS}+12$
			$V_{SS}-0.3$ to $V_{DD}+0.3$
Output current	I_{OUT}	50	mA
Power dissipation	P_D	SC-82AB	150
		SOT-23-5	250
		SOT-89-3	500
		SNT-4A	140
		TO-92	400
Operating ambient temperature	T_{opr}	-40 to +85	°C
Storage temperature	T_{stg}	-40 to +125	

Caution The absolute maximum ratings are rated values exceeding which the product could suffer physical damage. These values must therefore not be exceeded under any conditions.

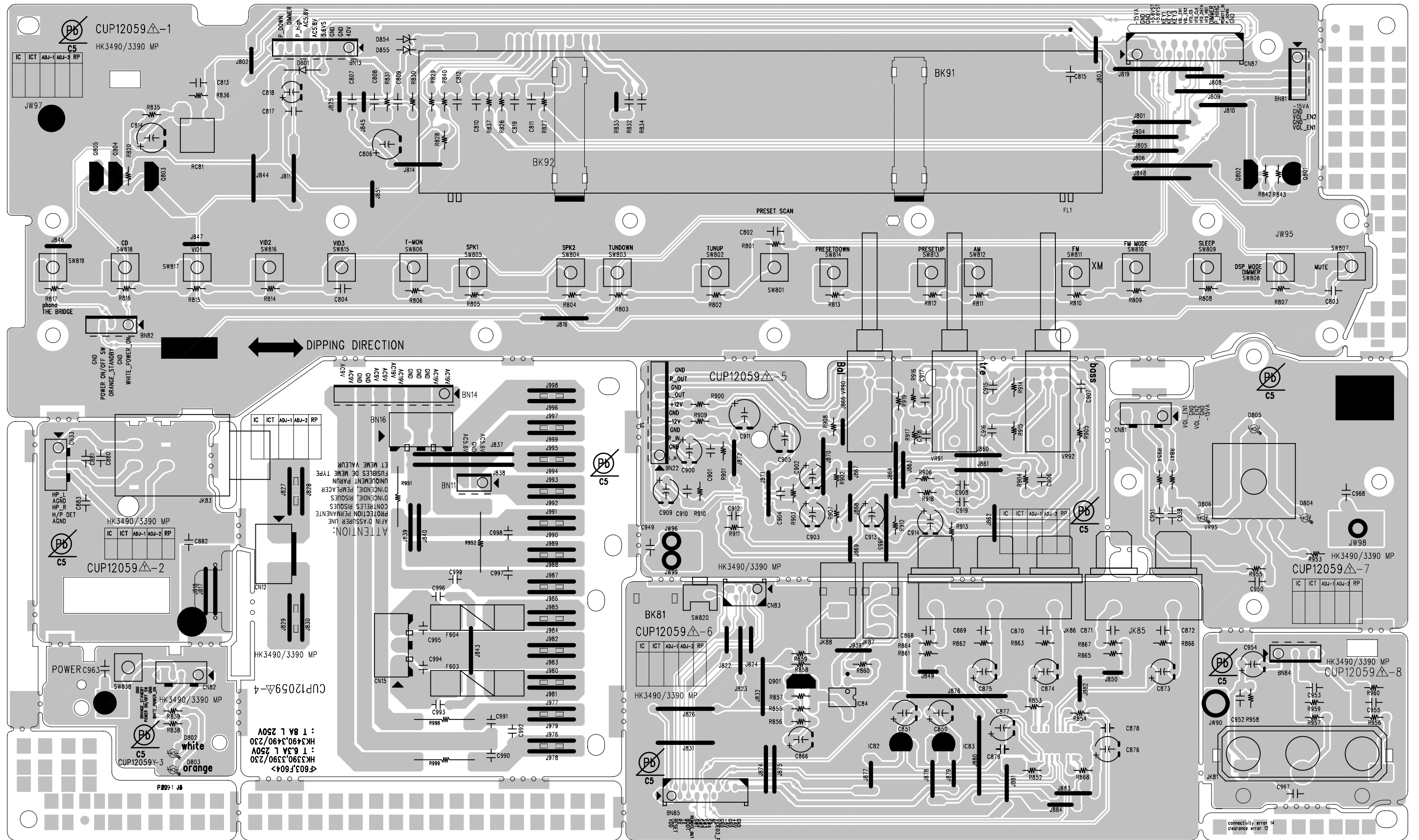

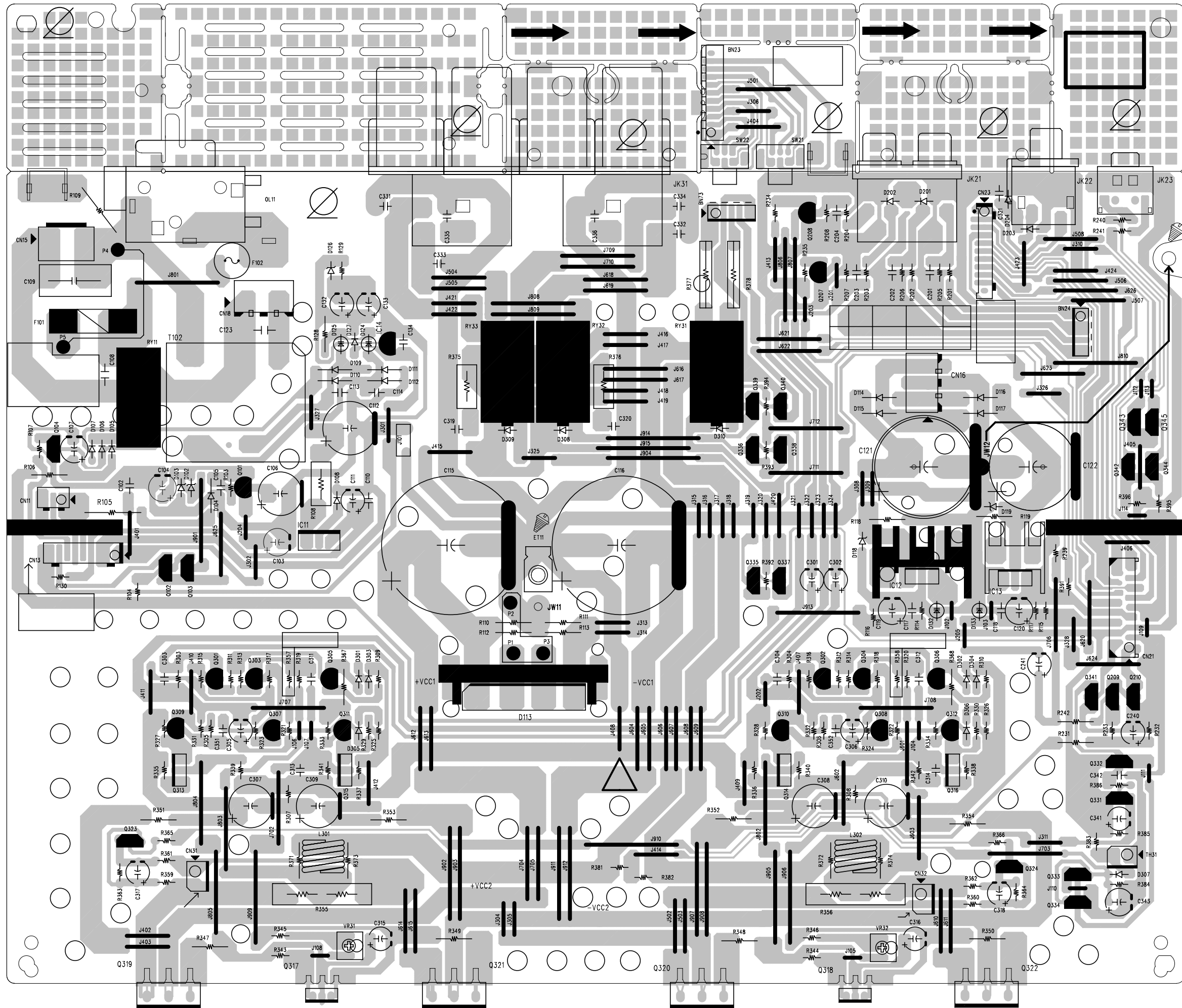

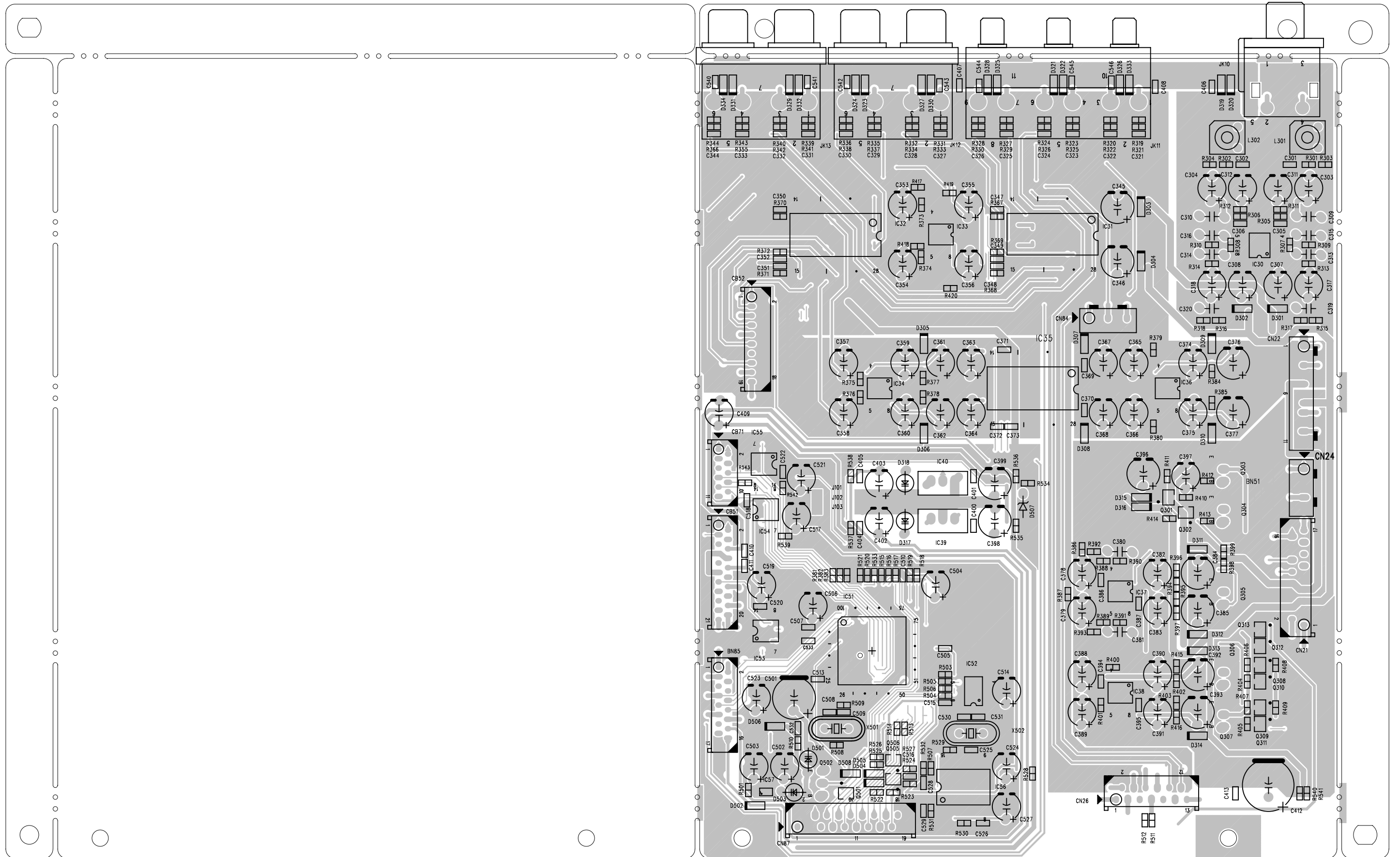

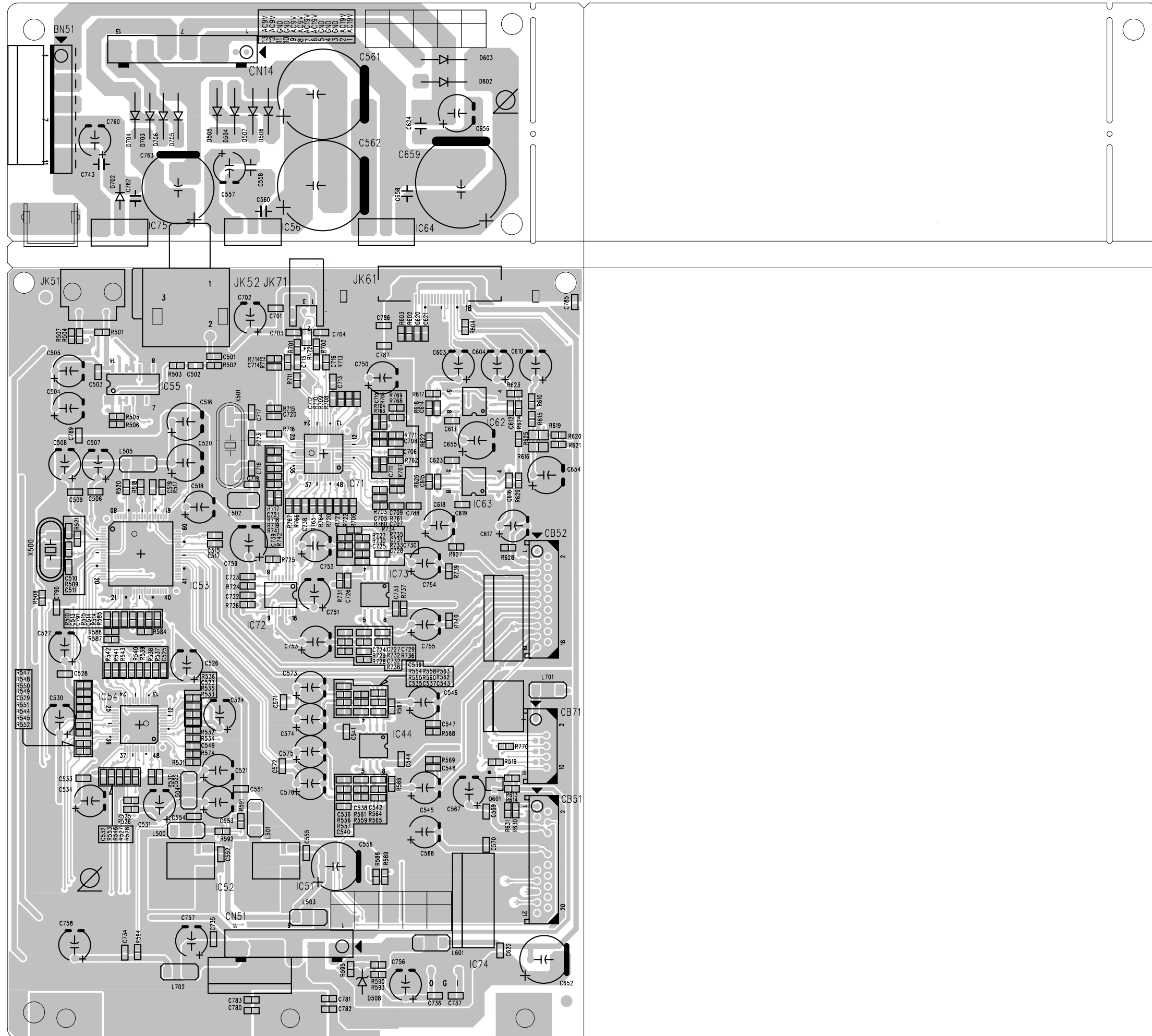

6 5 4 3 2 1

HK3390/3490 BLOCK DIAGRAM

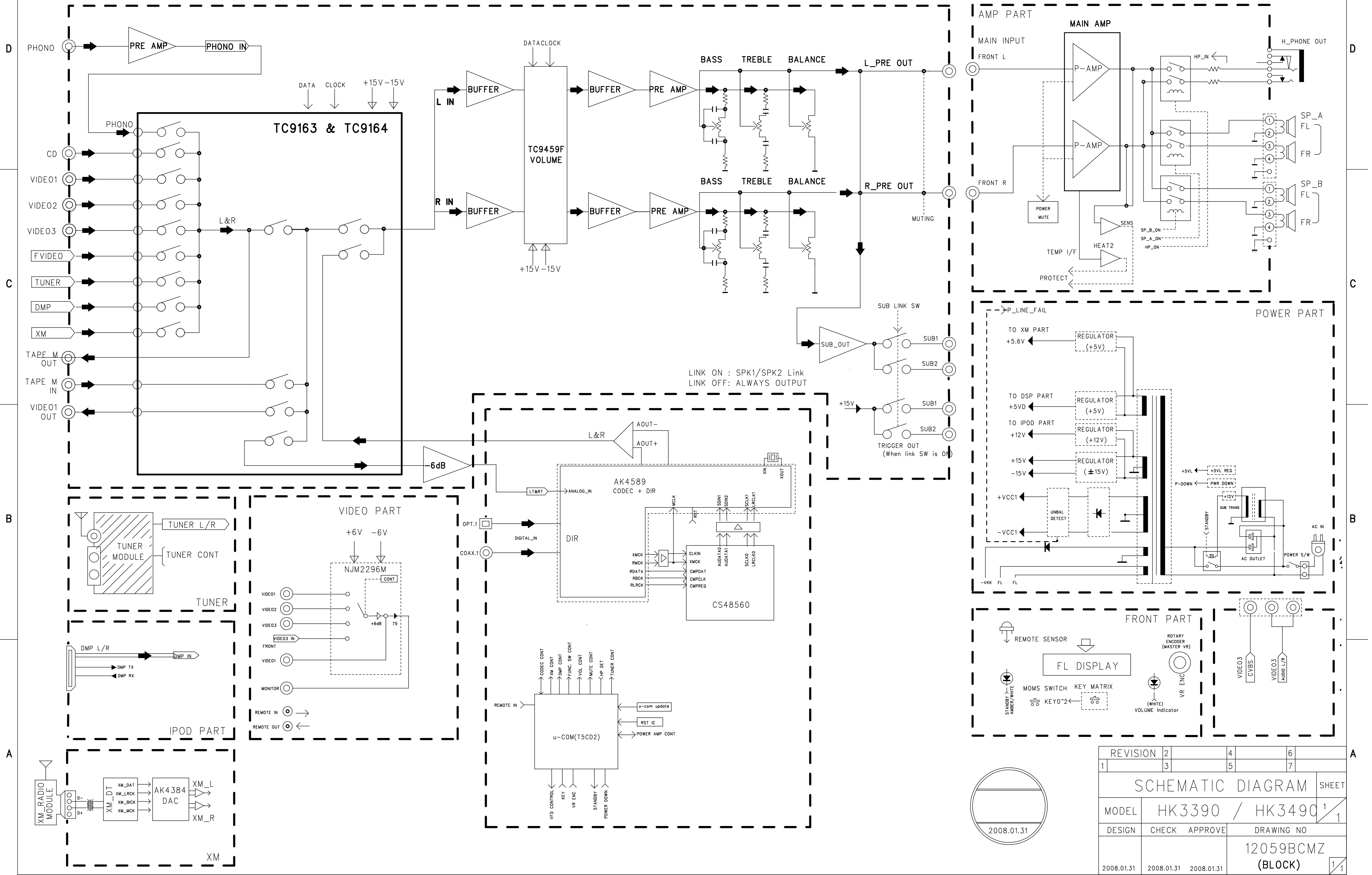

REVISION	2	4	6
1	3	5	7
SCHEMATIC DIAGRAM SHEET			
MODEL	HK3390 / HK3490 1/1		
DESIGN	CHECK	APPROVE	DRAWING NO
			12059BCMZ
			(BLOCK)
2008.01.31	2008.01.31	2008.01.31	1/1

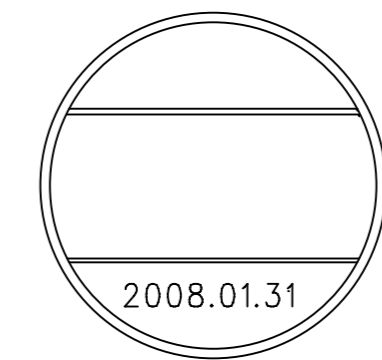

HK3390/3490 WIRING DIAGRAM

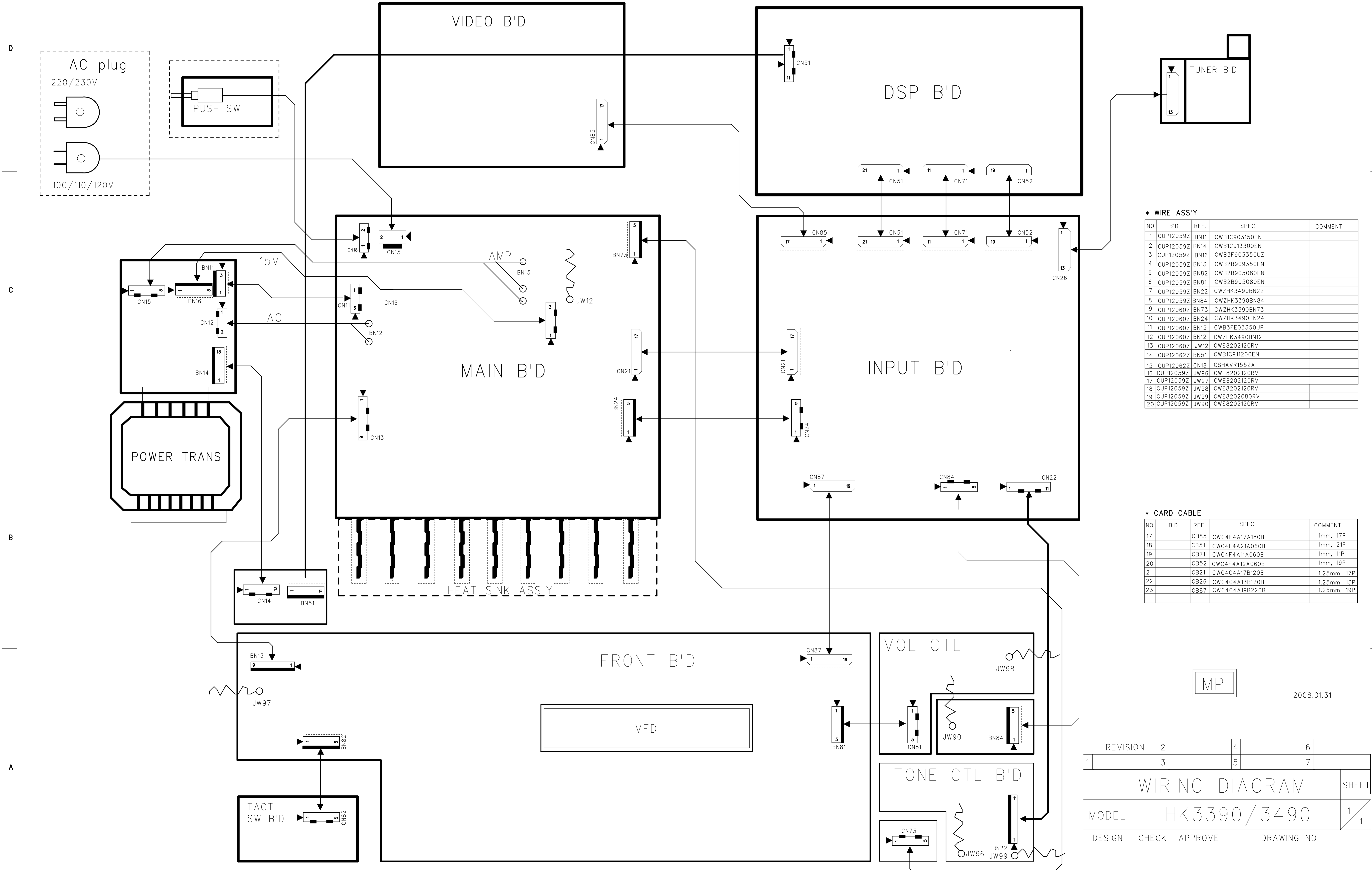

*** WIRE ASS'Y**

NO	B'D	REF.	SPEC	COMMENT
1	CUP12059Z	BN11	CWB1C903150EN	
2	CUP12059Z	BN14	CWB1C913300EN	
3	CUP12059Z	BN16	CWB3F903350UZ	
4	CUP12059Z	BN13	CWB2B909350EN	
5	CUP12059Z	BN82	CWB2B905080EN	
6	CUP12059Z	BN81	CWB2B905080EN	
7	CUP12059Z	BN22	CWZHK3490BN22	
8	CUP12059Z	BN84	CWZHK3390BN84	
9	CUP12060Z	BN73	CWZHK3390BN73	
10	CUP12060Z	BN24	CWZHK3490BN24	
11	CUP12060Z	BN15	CWB3FE03350UP	
12	CUP12060Z	BN12	CWZHK3490BN12	
13	CUP12060Z	JW12	CWE8202120RV	
14	CUP12062Z	BN51	CWB1C911200EN	
15	CUP12062Z	CN18	CSHAVR1552A	
16	CUP12059Z	JW96	CWE8202120RV	
17	CUP12059Z	JW97	CWE8202120RV	
18	CUP12059Z	JW98	CWE8202120RV	
19	CUP12059Z	JW99	CWE8202080RV	
20	CUP12059Z	JW90	CWE8202120RV	

*** CARD CABLE**

NO	B'D	REF.	SPEC	COMMENT
17		CB85	CWC4F4A17A180B	1mm, 17P
18		CB51	CWC4F4A21A060B	1mm, 21P
19		CB71	CWC4F4A11A060B	1mm, 11P
20		CB52	CWC4F4A19A060B	1mm, 19P
21		CB21	CWC4C4A17B120B	1.25mm, 17P
22		CB26	CWC4C4A13B120B	1.25mm, 13P
23		CB87	CWC4C4A19B220B	1.25mm, 19P

MP

2008.01.31

REVISION	2	4	6
1	3	5	7
WIRING DIAGRAM			
MODEL HK3390/3490			
DESIGN	CHECK	APPROVE	DRAWING NO

HK3490/3390 idle current Adjustment

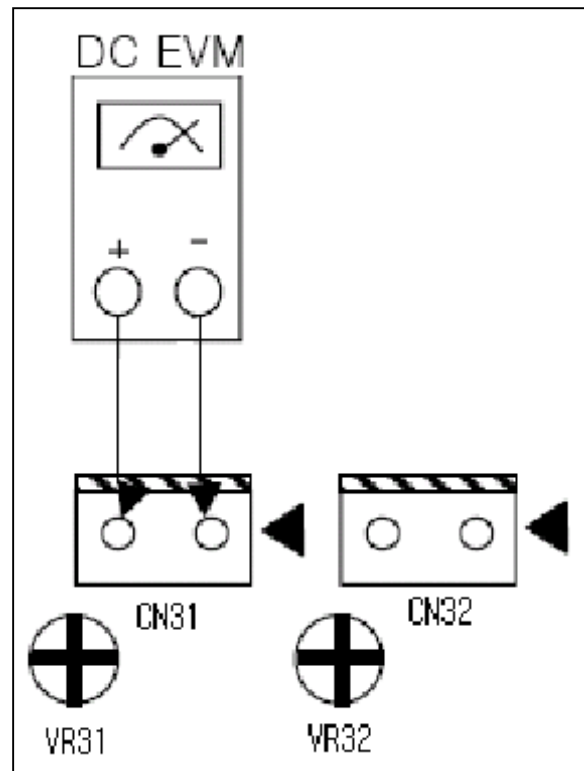

1. Adjust VR31 to set $21.12\text{mV}(\pm 5\%)$ on DC EVM.
2. Adjust VR32 as same way above.

D

D

C

C

B

B

A

A

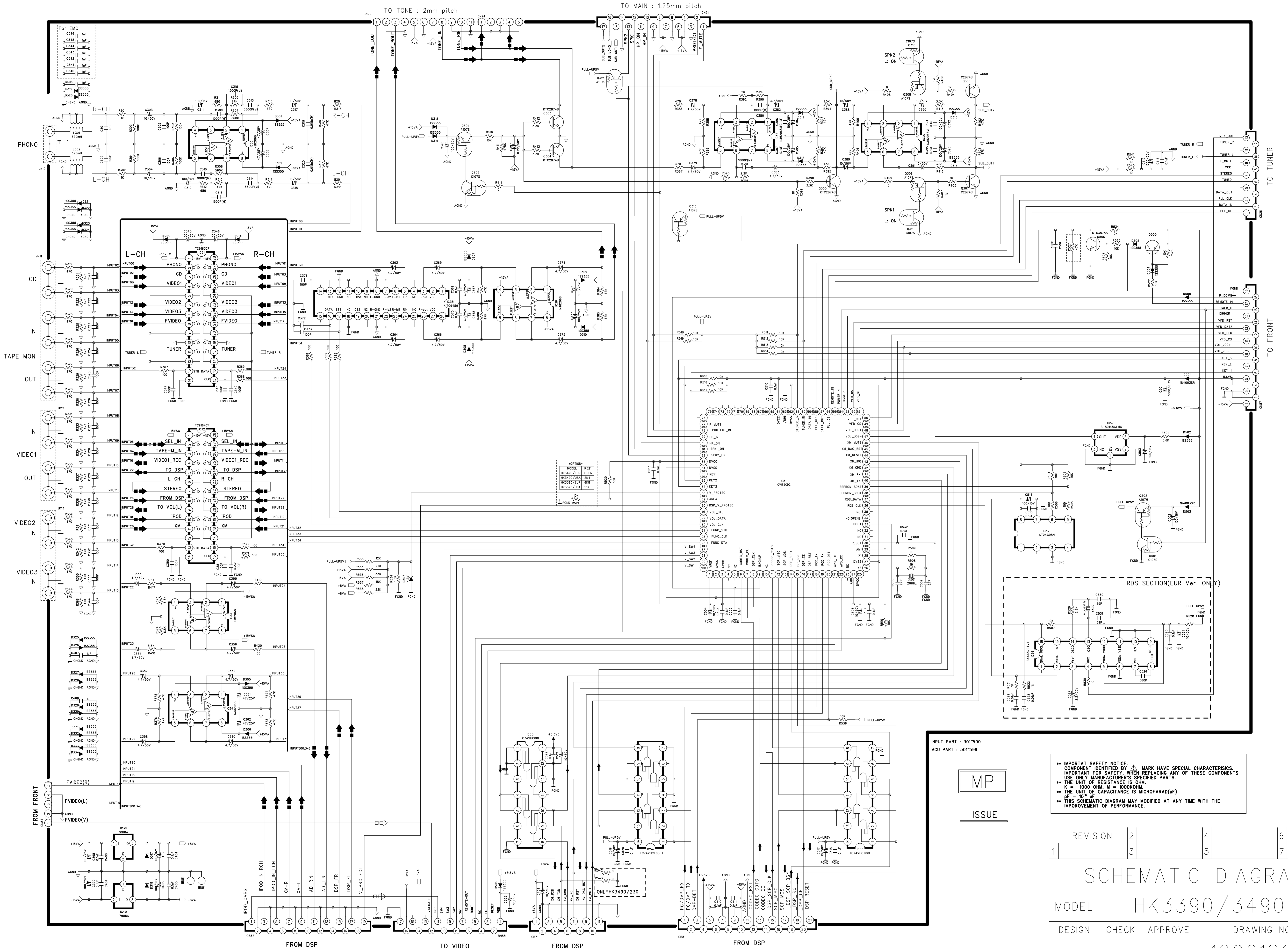

INPUT PART : 301*500
MCU PART : 501*599



ISSUE

- IMPORAT SAFETY NOTICE. COMPONENT IDENTIFIED BY MARK HAVE SPECIAL CHARACTERISTICS. IMPORTANT FOR SAFETY: WHEN REPLACING ANY OF THESE COMPONENTS USE ONLY MANUFACTURER'S SPECIFIED PARTS.
- THE UNIT OF RESISTANCE IS OHM.
- K = 1000 OHM, M = 10000OHM.
- THE UNIT OF CAPACITANCE IS MICROFARAD(UF)
- THIS SCHEMATIC DIAGRAM MAY MODIFIED AT ANY TIME WITH THE IMPROVEMENT OF PERFORMANCE.

REVISION	2	4	6
	3	5	7
SCHEMATIC DIAGRAM SHEET			
MODEL	HK3390/3490		
DESIGN	CHECK	APPROVE	DRAWING NO
			12061SCMY
			(INPUT)

6 5 4 3 2 1

D

C

B

A

D

C

B

A

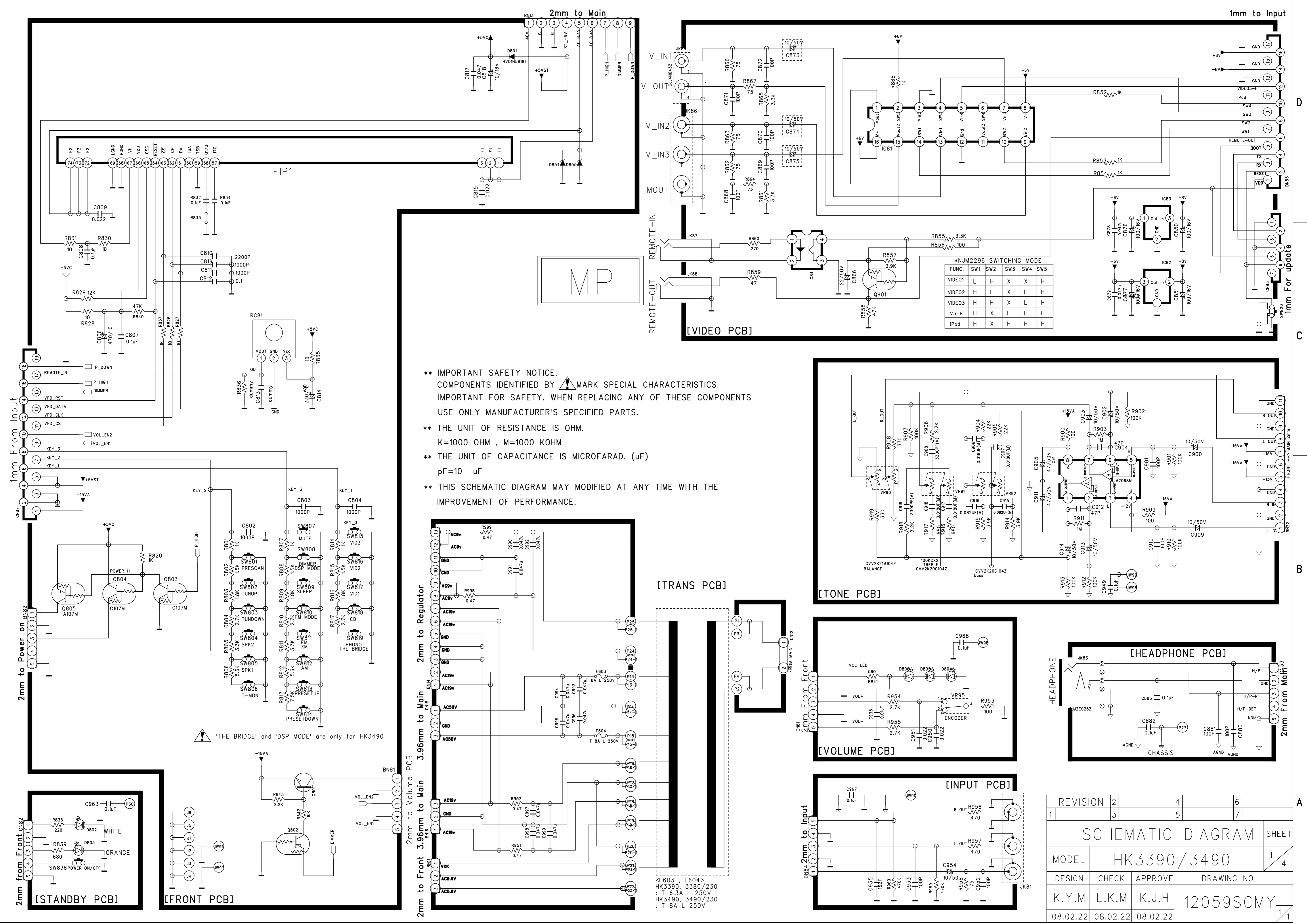

**** IMPORTANT SAFETY NOTICE.**
 COMPONENTS IDENTIFIED BY ▲ MARK SPECIAL CHARACTERISTICS.
 IMPORTANT FOR SAFETY. WHEN REPLACING ANY OF THESE COMPONENTS
 USE ONLY MANUFACTURER'S SPECIFIED PARTS.

**** THE UNIT OF RESISTANCE IS OHM.**
 K=1000 OHM , M=1000 KOHM

**** THE UNIT OF CAPACITANCE IS MICROFARAD. (uF)**
 pF=10 uF

**** THIS SCHEMATIC DIAGRAM MAY MODIFIED AT ANY TIME WITH THE
 IMPROVEMENT OF PERFORMANCE.**

*NJM2296 SWITCHING MODE

FUNC.	SW1	SW2	SW3	SW4	SW5
VIDEO1	L	H	X	X	H
VIDEO2	H	L	X	X	L
VIDEO3	H	H	X	L	H
V3-F	H	X	L	H	H
iPod	H	X	H	H	H

REVISION	2	4	6
1	3	5	7
SCHEMATIC DIAGRAM SHEET			
MODEL	HK3390/3490		
DESIGN	CHECK	APPROVE	DRAWING NO
K.Y.M	L.K.M	K.J.H	12059SCMY
08.02.22	08.02.22	08.02.22	

<F603, F604>
 HK3390, 3380/230
 : T 6.3A L 250V
 HK3490, 3490/230
 : T 8A L 250V

D

C

B

A

D

C

B

A

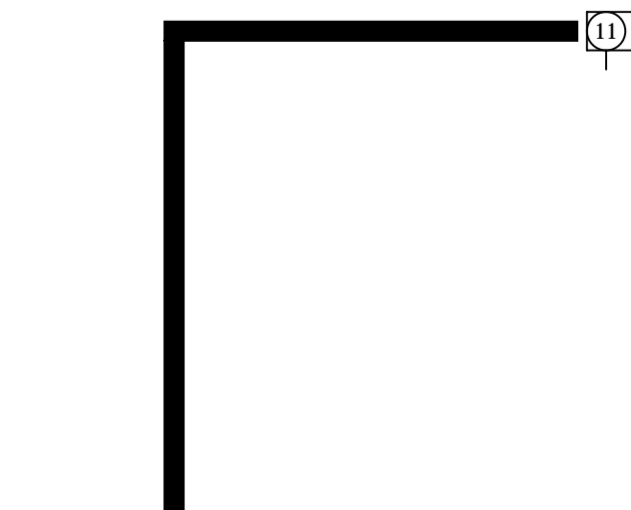
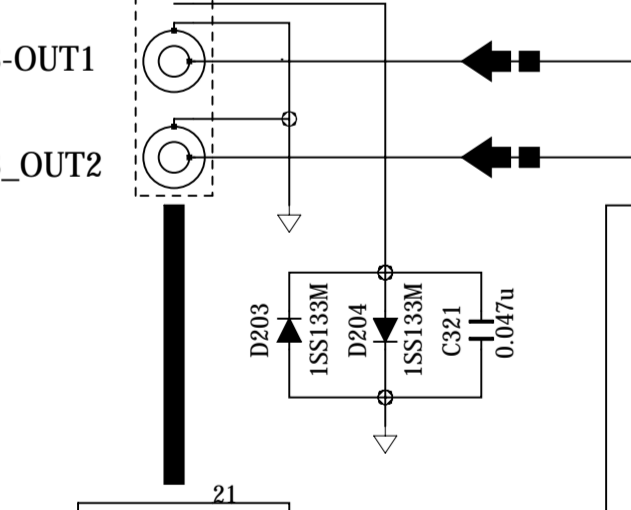
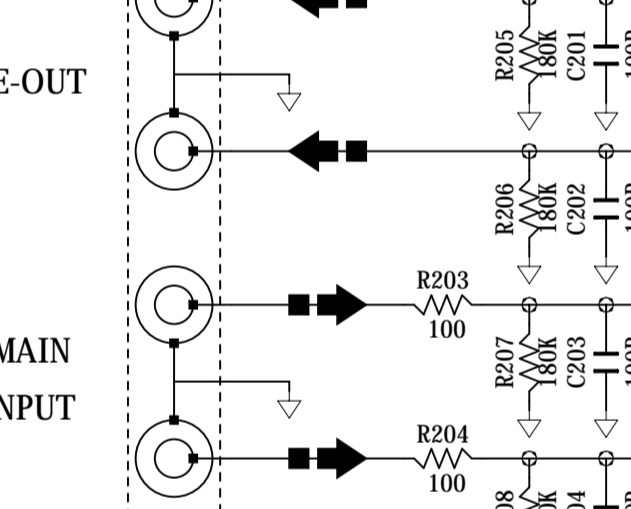
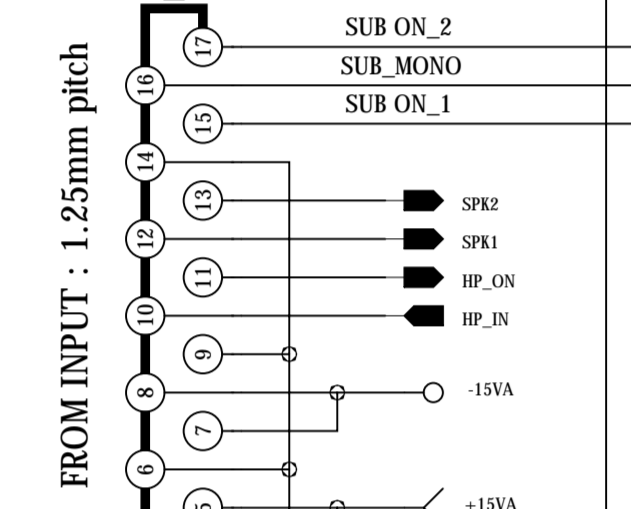
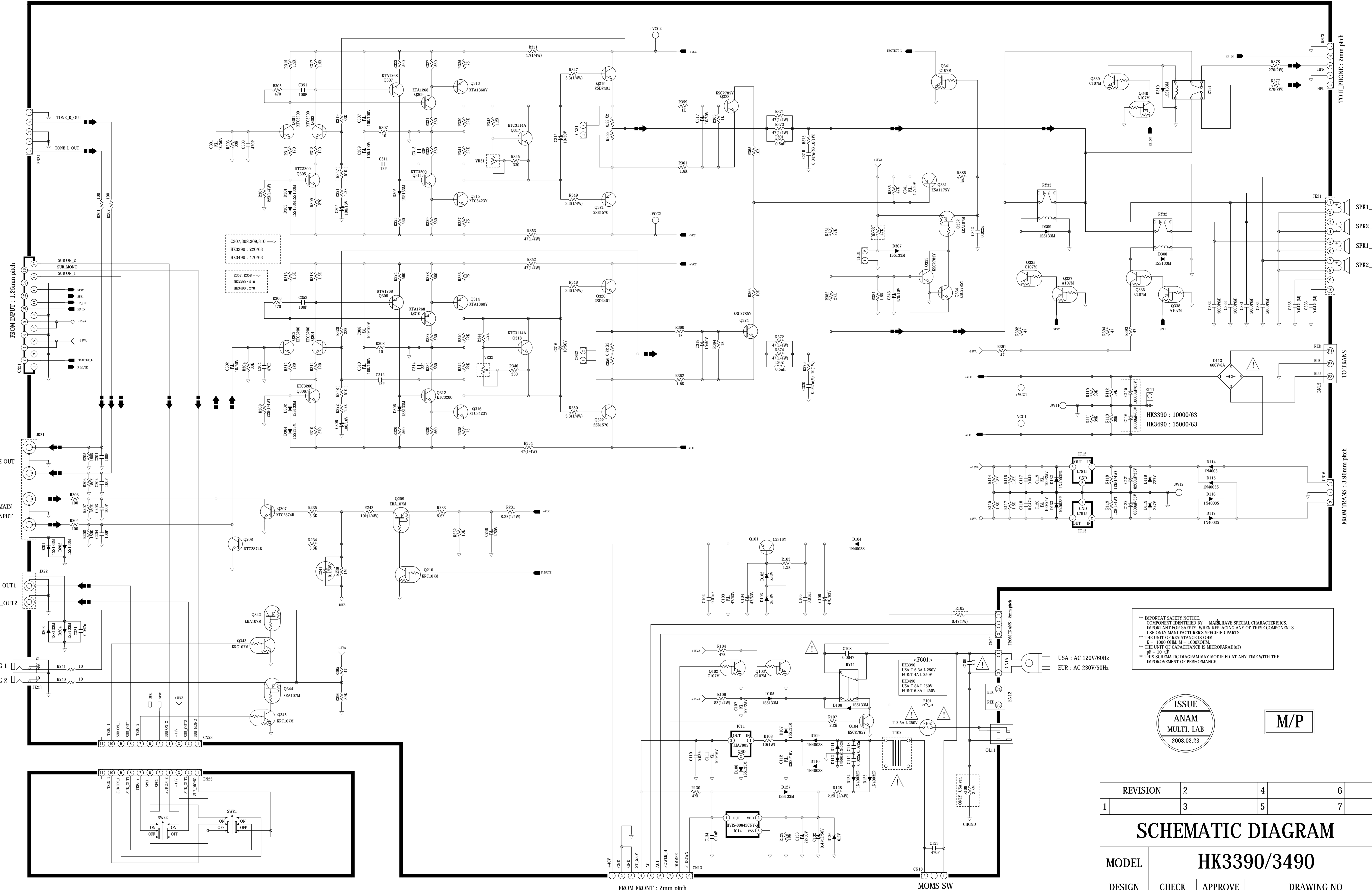

FROM FRONT : 2mm pitch

MOMS SW

TO H_PHONE : 2mm pitch

TO TRANS

FROM TRANS : 3.96mm pitch

**** IMPORTANT SAFETY NOTICE.**
 COMPONENT IDENTIFIED BY **MA** HAVE SPECIAL CHARACTERISTICS.
 IMPORTANT FOR SAFETY. WHEN REPLACING ANY OF THESE COMPONENTS
 USE ONLY MANUFACTURER'S SPECIFIED PARTS.
 ** THE UNIT OF RESISTANCE IS OHM.
 K = 1000 OHM, M = 10000 OHM.
 ** THE UNIT OF CAPACITANCE IS MICROFARAD(μF).
 μF = 10⁻⁶.
 ** THIS SCHEMATIC DIAGRAM MAY MODIFIED AT ANY TIME WITH THE
 IMPROVEMENT OF PERFORMANCE.

ISSUE
 ANAM
 MULTI. LAB
 2008.02.23

M/P

REVISION	2	4	6
1	3	5	7
SCHEMATIC DIAGRAM			
MODEL	HK3390/3490		SHEET 2 4
DESIGN	CHECK	APPROVE	DRAWING NO
Choi.D.C	Lee.K.M	Kim.J.H	12060SCMY
08.02.23	08.02.23	08.02.23	(MAIN)

DSP PART

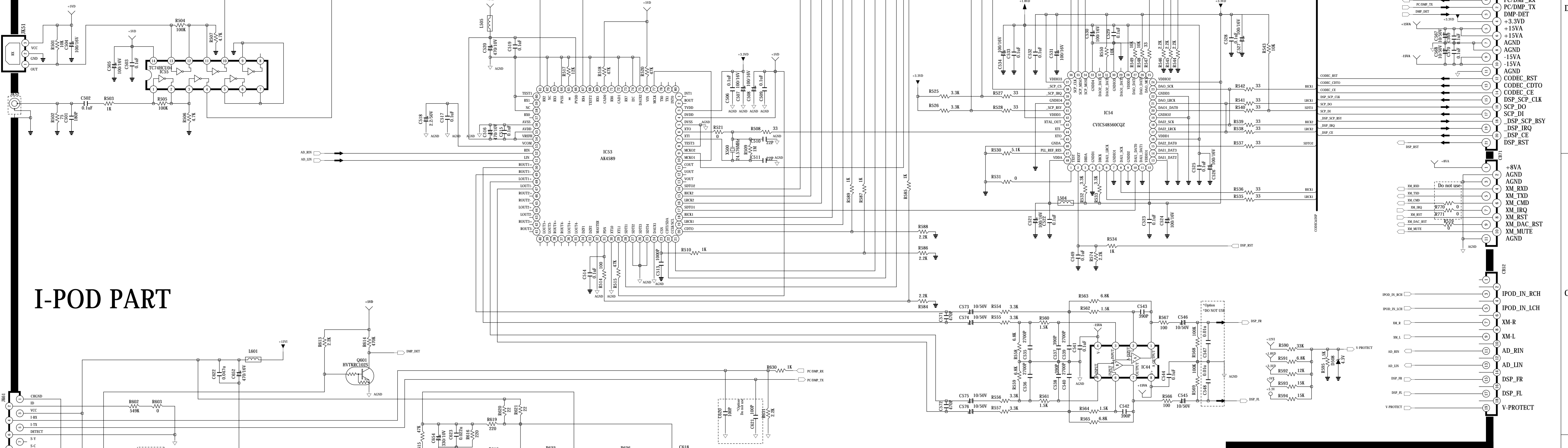

I-POD PART

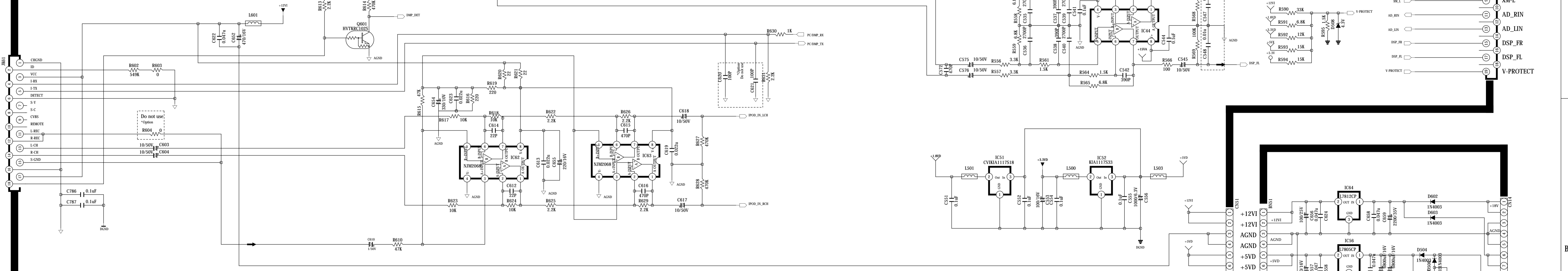

XM READY PART

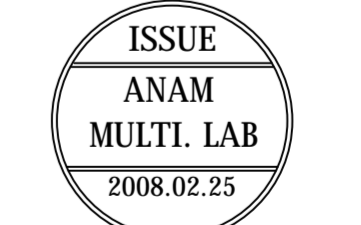
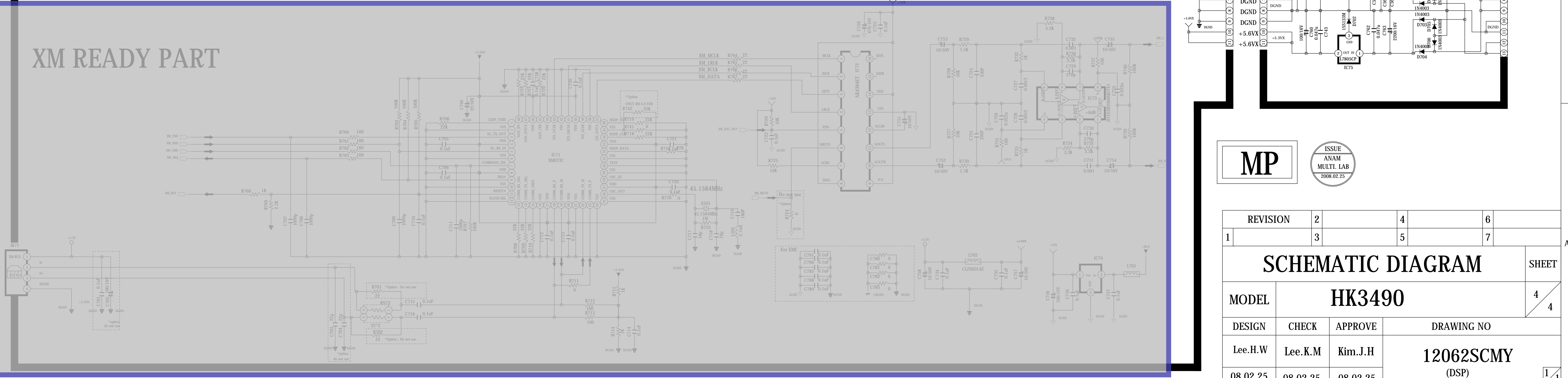

REVISION	2	4	6	
1	3	5	7	
SCHEMATIC DIAGRAM				SHEET
MODEL	HK3490			4 4
DESIGN	CHECK	APPROVE	DRAWING NO	
Lee.H.W	Lee.K.M	Kim.J.H	12062SCMY	
08.02.25	08.02.25	08.02.25	(DSP)	