

The Harman/Kardon Model 230e

ERIC NELSON
CUSTOMER SERVICE DEPT.

AM/FM/FM Stereo Solid State Receiver

Technical Manual



harman/kardon

TECHNICAL SPECIFICATIONS

Amplifier-Section

Power Output:	15 watts min. RMS per channel, both channels driven into 8 ohms from 20Hz to 20kHz, with less than 0.5% THD.
Power Bandwidth:	From 10Hz to 60Hz at less than 1% THD into 8 ohms, both channels driven simultaneously at 7.5 watts per channel.
Frequency Response:	From 5Hz to 80kHz. - 3dB at less than 0.5% THD.
Square Wave Rise Time:	Better than 5 microseconds.
Square Wave Tilt:	Less than 5% at 20Hz full output.
Total Harmonic Distortion:	Less than 0.5% from 250 milliwatts, to 15 watts RMS, both channels driven simultaneously into 8 ohms from 20Hz to 20kHz.
Intermodulation Distortion:	Less than 0.2% at rated power output.
System Hum and Noise:	Better than 60dB below rated output (unweighted).
Damping Factor:	30.
Input Sensitivity:	Phono: 3mV. Aux: 200mV.
Input Impedance:	Phono: 47,000 ohms. Aux: 20,000 ohms.
Overload:	Phono: 70mV at 1kHz. Aux: Related to volume control setting.
RIAA Equalization:	±1dB.

Tuner Section

FM Sensitivity:	5 microvolts, IHF
Capture Ratio:	3dB.
Image Rejection:	40dB.
Alternate Channel Selectivity:	40dB.
Multiplex Separation:	25dB at 1kHz.
Dimensions:	16"W x 14"D x 4-1/4"H. (406mm x 356mm x 108mm).
Weight:	14 lbs (6.4kg).

PRECAUTIONS

1. Always disconnect the chassis from power line when soldering. Turning the power switch OFF is not enough. Power line leakage passing through the heating element may destroy the transistors.
2. Never attempt to do any work on the transistor amplifiers without first disconnecting the AC line cord and waiting until the power supply filter capacitors have discharged.
3. Replacement for output and driver transistors, if necessary, must be made from the same beta group as the original type.
4. If one output transistor burns out (open or short) always remove all the output transistors in that channel and check the bias adjustment, the control and other parts in the network with an ohmmeter before inserting a new transistor. All transistors in one channel will be destroyed if the base biasing circuit is open on the emitter end.
5. When mounting a replacement power transistor, be sure that the bottom of the flange, the mica insulators and the surface of the heat sink are free of foreign matter, for they may cause transistor failure.
6. Silicon grease must be applied between the transistor and the mica insulator, and between the mica insulator and the heat sink for better heat conduction.
7. Fuses must be replaced with size and type indicated. Use of other types can expose components to destructive current levels.
8. Use a non-conductive, non-ferrous tool when making alignment adjustments. Perform all specifications tests with all covers and escutcheon in place.

The Harmon Kardon model 230e stereo receiver was manufactured in two versions. The earlier units did not feature a lighted dial scale, stereo indicator or balance control as do the later units.

This manual, which includes both versions, primarily covers the later units. The earlier version difference data is covered in the rear section of this manual.

ALIGNMENT PROCEDURES

AM ALIGNMENT PROCEDURE

INSTRUMENTS: AM Signal Generator modulated with 400Hz at 30%.
AM IF Sweep Generator and Oscilloscope.
VTVM.

NOTE: Depress the AM Pushbutton (Button IN).
Connect signal source to a placed to radiate signal into AM Antenna Loop Stick (L1).

Step	SIGNAL SOURCE	CONNECT OUTPUT METER TO	DIAL SETTING	ADJUST	ADJUST FOR
1	455kHz of AM IF Sweep Generator	VTVM and Oscilloscope to R135	Quiet point on band	T103	Maximum and top flat pattern on Oscilloscope
2	540kHz of AM Signal Generator	Same as above	540kHz	L106	Maximum output
3	1600kHz of AM Signal Generator	Same as above	1600kHz	TC5	Same as above
4	Repeat Steps 2 and 3 for best dial accuracy				
5	600kHz of AM Signal Generator	Same as above	600kHz	L1	Same as above
6	1600kHz of AM Signal Generator	Same as above	1600kHz	TC4	Same as above
7	Repeat Steps 5 and 6 for best sensitivity				

MPX ALIGNMENT PROCEDURE

INSTRUMENT: Frequency Counter.

NOTE: Depress the FM Pushbutton (Button IN).

CONNECT OUTPUT METER TO	DIAL SETTING	ADJUST	ADJUST FOR
Frequency Counter to R151	Quiet Point	VR102	19kHz \pm 100Hz

STEREO THRESHOLD ALIGNMENT PROCEDURE

INSTRUMENTS: FM Stereo Signal Generator.

NOTE: Depress the FM Pushbutton (Button IN).
Connect signal source to FM Antenna Terminal.
Set Main signal ON and Pilot signal (10%) ON of FM Stereo Signal Generator.
Set VR103 fully counter-clockwise.

Step	SIGNAL SOURCE	DIAL SETTING	ADJUST	ADJUST FOR
1	98MHz 22.5 μ V (27dB)	98MHz	VR103	Turn VR103 clockwise until FM Stereo Indicator (D1) just goes OFF
2	To raise the signal source by 1dB and confirm that FM Stereo Indicator (D1) lights at this position			

**WIRING DIAGRAM – MODEL 230e
REGULAR VOLTAGE**

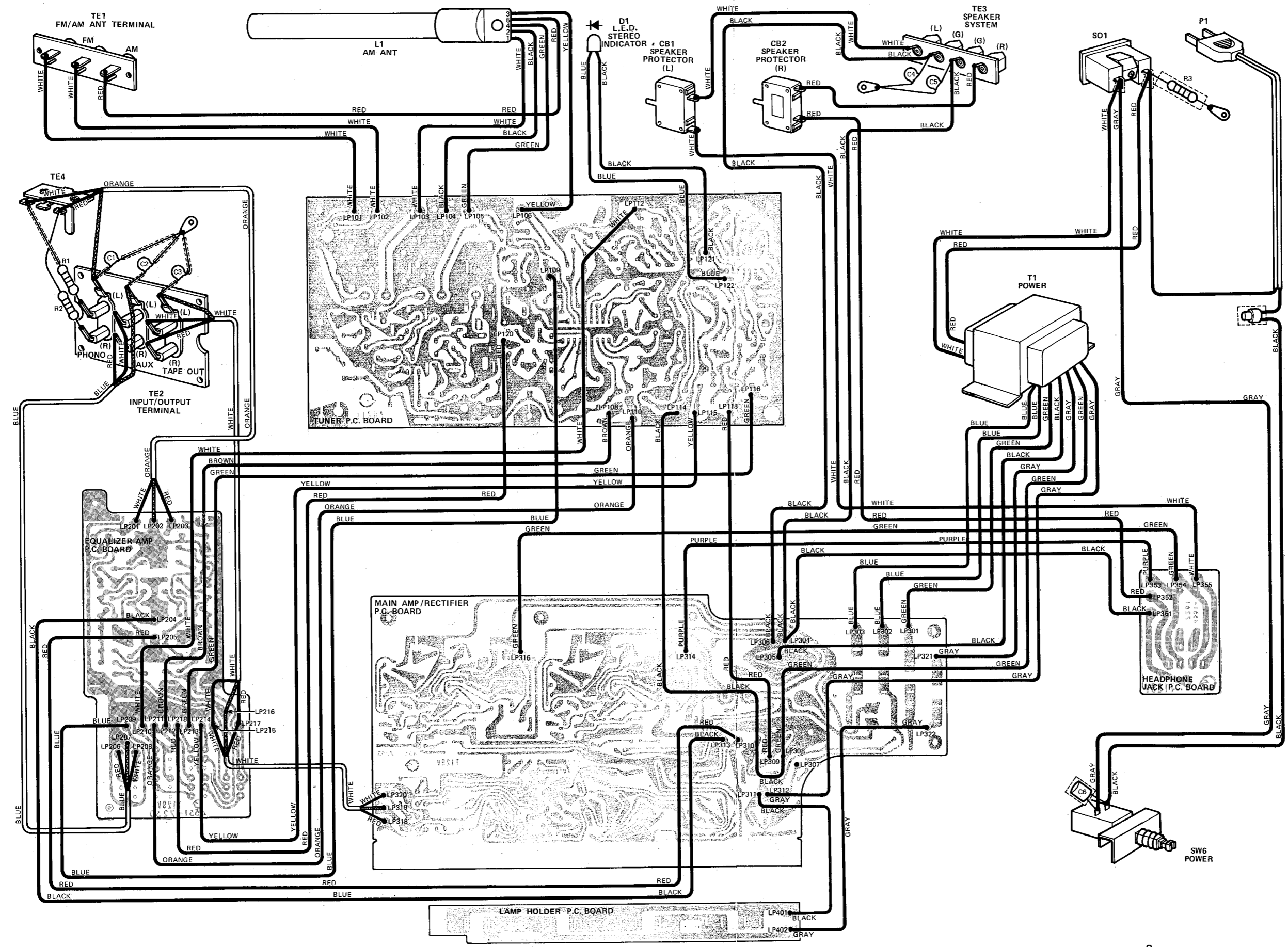

WIRING DIAGRAM – MODEL 230e REGULAR VOLTAGE

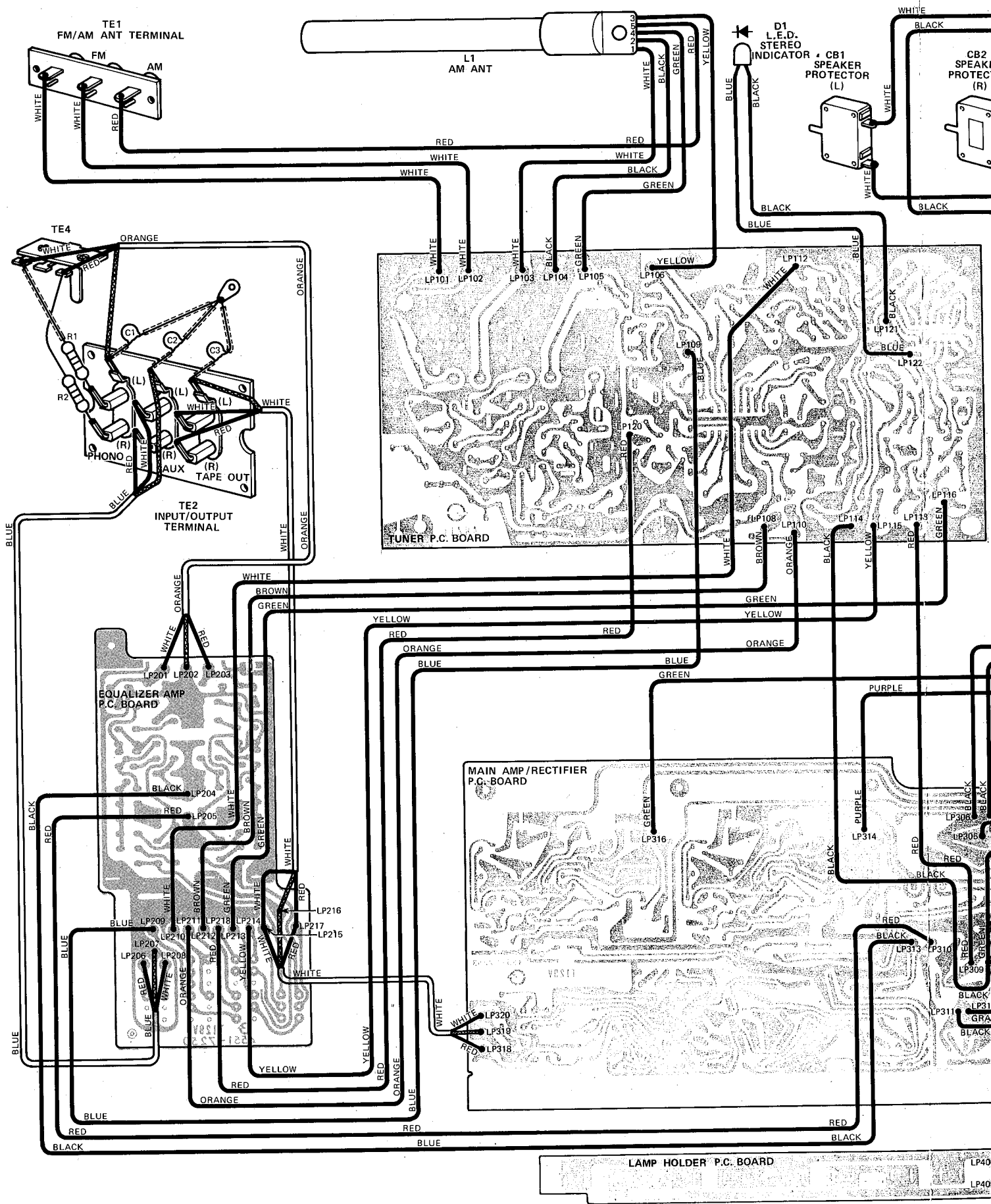

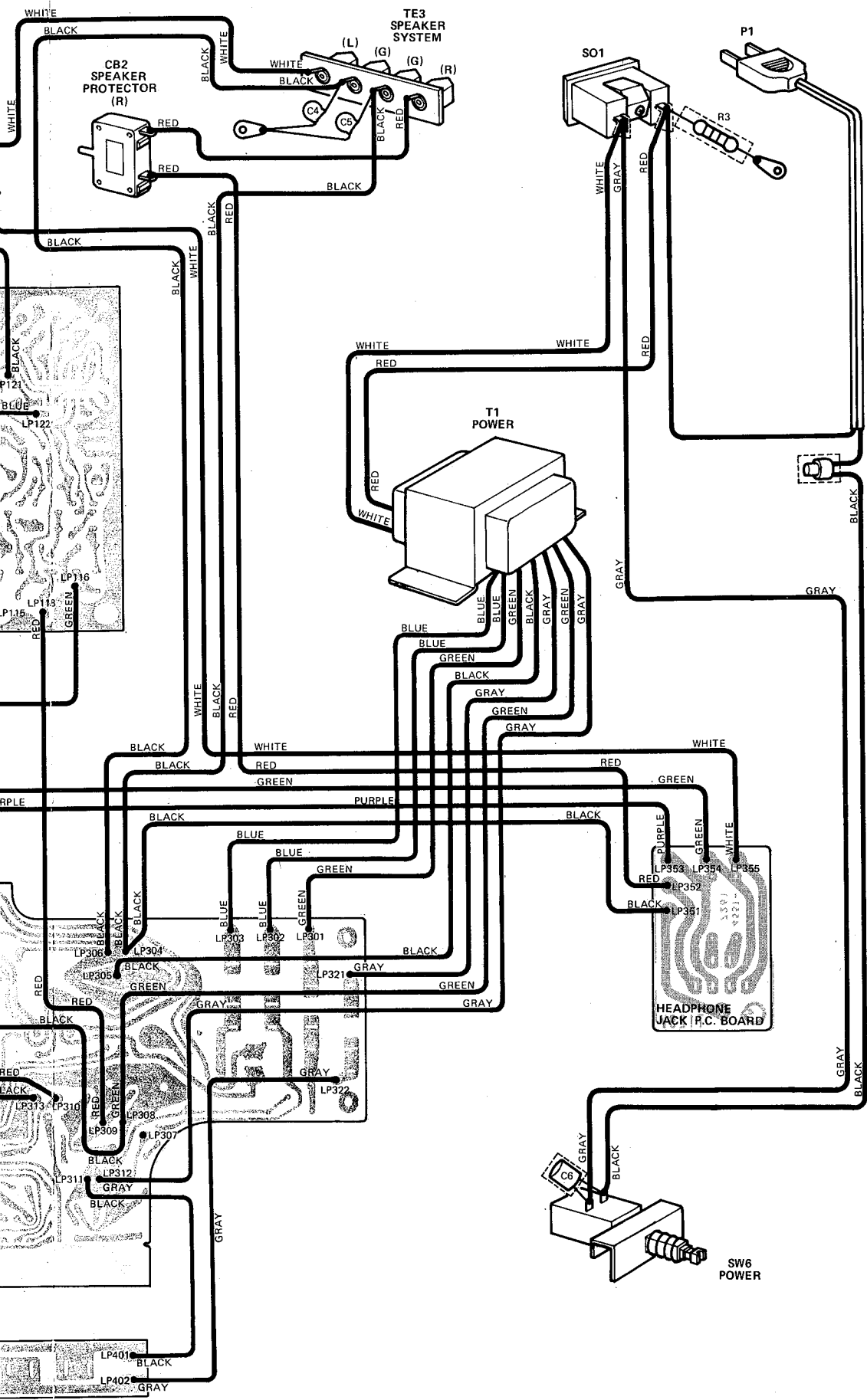

ALIGNMENT PROCEDURES

FM ALIGNMENT PROCEDURE

INSTRUMENTS: FM Signal Generator modulated with 400Hz at 75kHz.
FM IF Sweep Generator and Oscilloscope.
Distortion Meter.
VTVM.

NOTE: Depress the FM Pushbutton (Button IN).

Step	SIGNAL SOURCE	CONNECT SIGNAL SOURCE TO	CONNECT OUTPUT METER TO	DIAL SETTING	ADJUST	ADJUST FOR
1	10.7MHz of FM IF Sweep Generator	L103	Oscilloscope to cathode of D102	Quiet Point on band	T101 top and bottom	Maximum and undistorted pattern on Oscilloscope
2	Same as above	Same as above	Oscilloscope to LP119	Same as above	T102 top	Maximum and balanced "S" curve on Oscilloscope
3	98MHz 1mV (60dB) of FM Signal Generator	FM Antenna Terminal	Distortion Meter to Tape Output Jack	Same as above	T102 bottom	Minimum output on Distortion Meter
4	Repeat Steps 1 through 3 until no further improvement is noticed					
5	88MHz 5 μ V(14dB) of FM Signal Generator	Same as above	VTVM and Oscilloscope to Tape Output Jack	88MHz	L104	Maximum output
6	108MHz 5 μ V(14dB) of FM Signal Generator	Same as above	Same as above	108MHz	TC3	Same as above
7	Repeat Steps 5 and 6 for best dial accuracy					
8	90MHz 5 μ V(14dB) of FM Signal Generator	Same as above	Same as above	90MHz	L101 L102	Same as above
9	106MHz 5 μ V(14dB) of FM Signal Generator	Same as above	Same as above	106MHz	TC1 TC2	Same as above
10	Repeat Steps 8 and 9 for best sensitivity					

DIAL CORD STRINGING

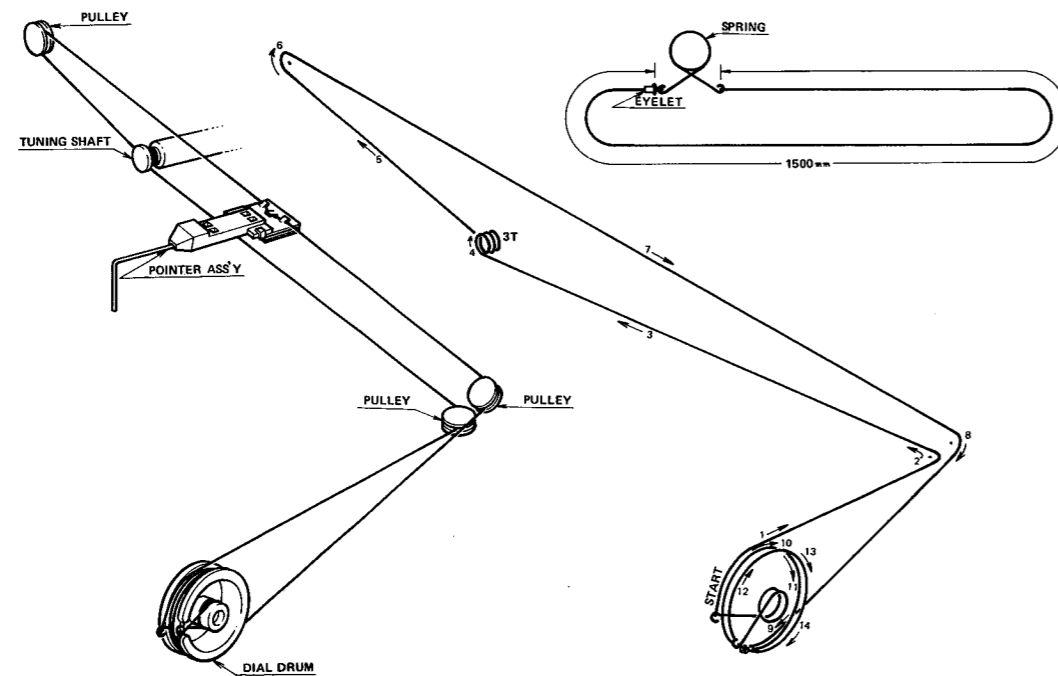

Start stringing with Variable Capacitor in closed position.

ALIGNMENT POINTS

TOP VIEW

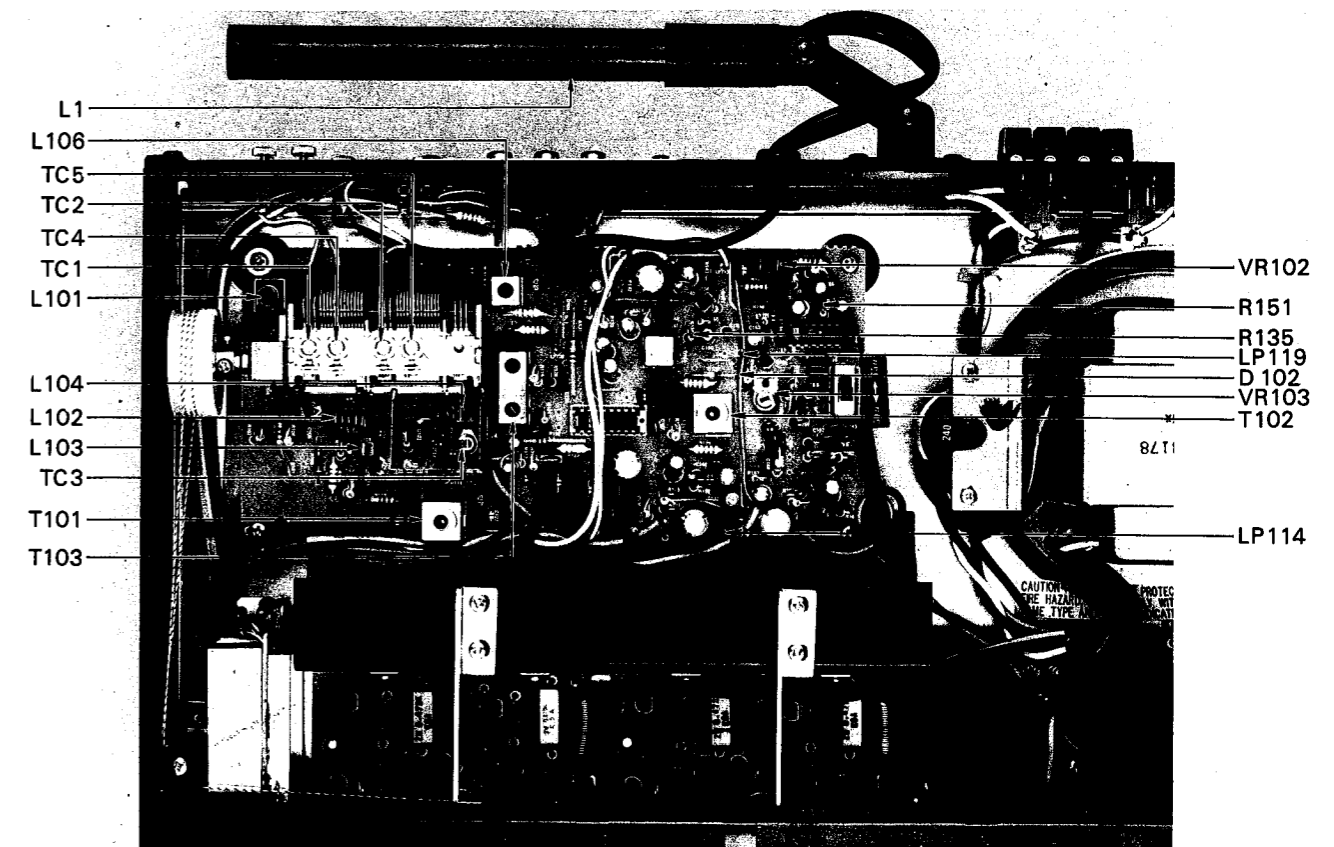

BOTTOM VIEW

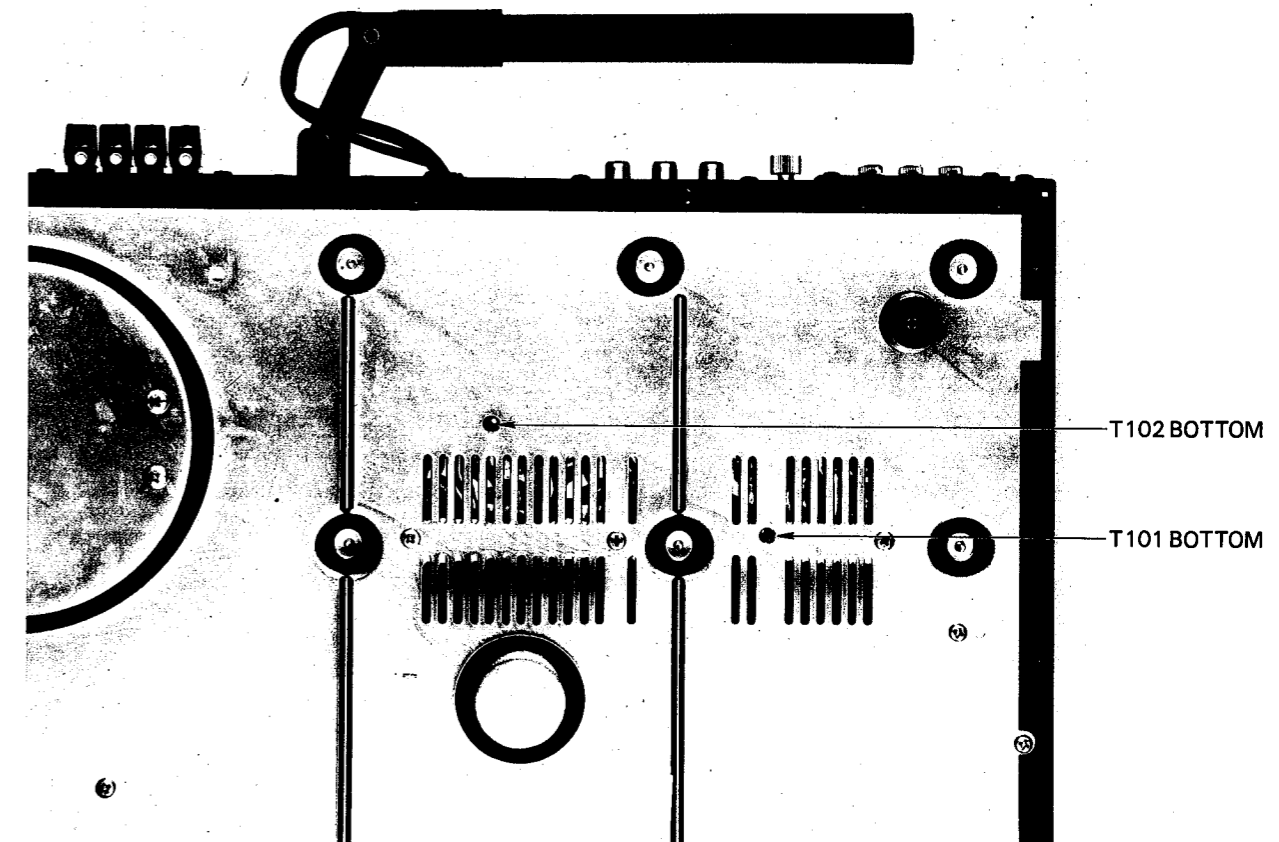

ALIGNMENT PROCEDURES

FM ALIGNMENT PROCEDURE

INSTRUMENTS: FM Signal Generator modulated with 400Hz at 75kHz.
 FM IF Sweep Generator and Oscilloscope.
 Distortion Meter.
 VTVM.

NOTE: Depress the FM Pushbutton (Button IN).

Step	SIGNAL SOURCE	CONNECT SIGNAL SOURCE TO	CONNECT OUTPUT METER TO	DIAL SETTING	ADJUST	ADJUST FOR
1	10.7MHz of FM IF Sweep Generator	L103	Oscilloscope to cathode of D102	Quiet Point on band	T101 top and bottom	Maximum and undistorted pattern on Oscilloscope
2	Same as above	Same as above	Oscilloscope to LP119	Same as above	T102 top	Maximum and balanced "S" curve on Oscilloscope
3	98MHz 1mV (60dB) of FM Signal Generator	FM Antenna Terminal	Distortion Meter to Tape Output Jack	Same as above	T102 bottom	Minimum output on Distortion Meter
4	Repeat Steps 1 through 3 until no further improvement is noticed					
5	88MHz 5 μ V(14dB) of FM Signal Generator	Same as above	VTVM and Oscilloscope to Tape Output Jack	88MHz	L104	Maximum output
6	108MHz 5 μ V(14dB) of FM Signal Generator	Same as above	Same as above	108MHz	TC3	Same as above
7	Repeat Steps 5 and 6 for best dial accuracy					
8	90MHz 5 μ V(14dB) of FM Signal Generator	Same as above	Same as above	90MHz	L101 L102	Same as above
9	106MHz 5 μ V(14dB) of FM Signal Generator	Same as above	Same as above	106MHz	TC1 TC2	Same as above
10	Repeat Steps 8 and 9 for best sensitivity					

DIAL CORD STRINGING

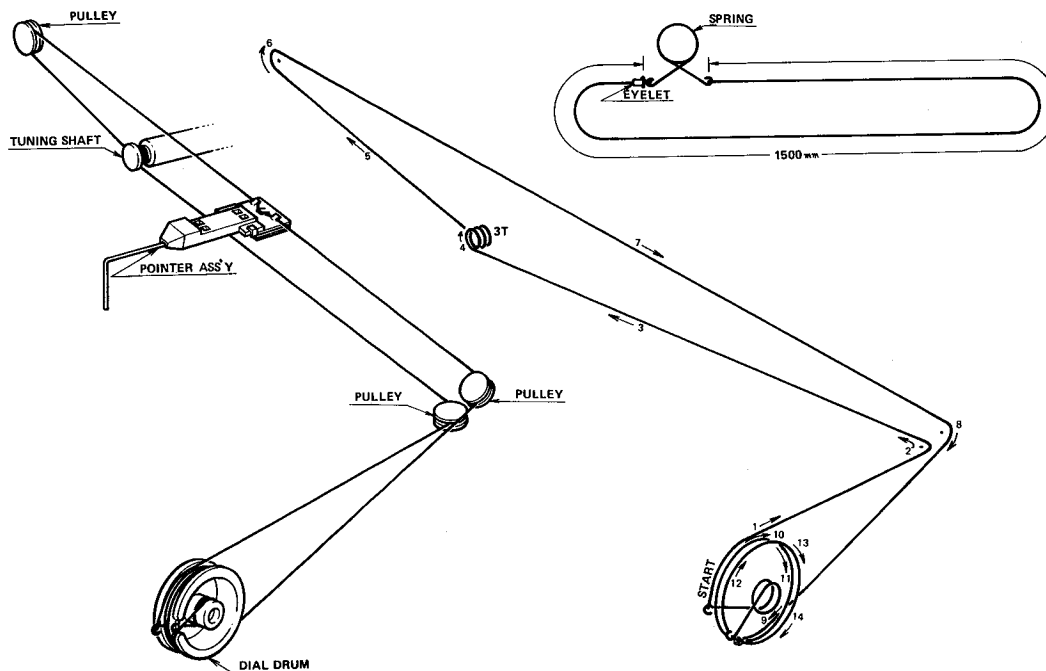

Start stringing with Variable Capacitor in closed position.

ALIGNMENT POINTS

TOP VIEW

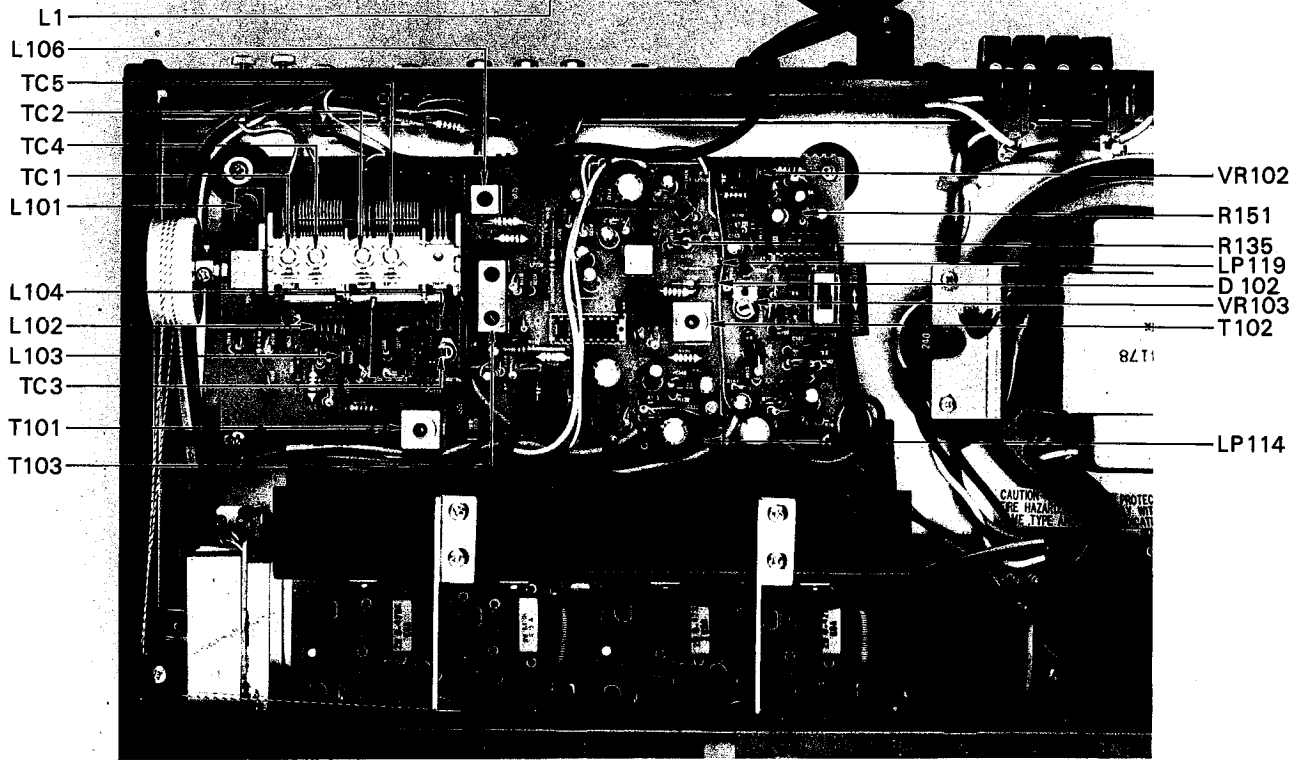

BOTTOM VIEW

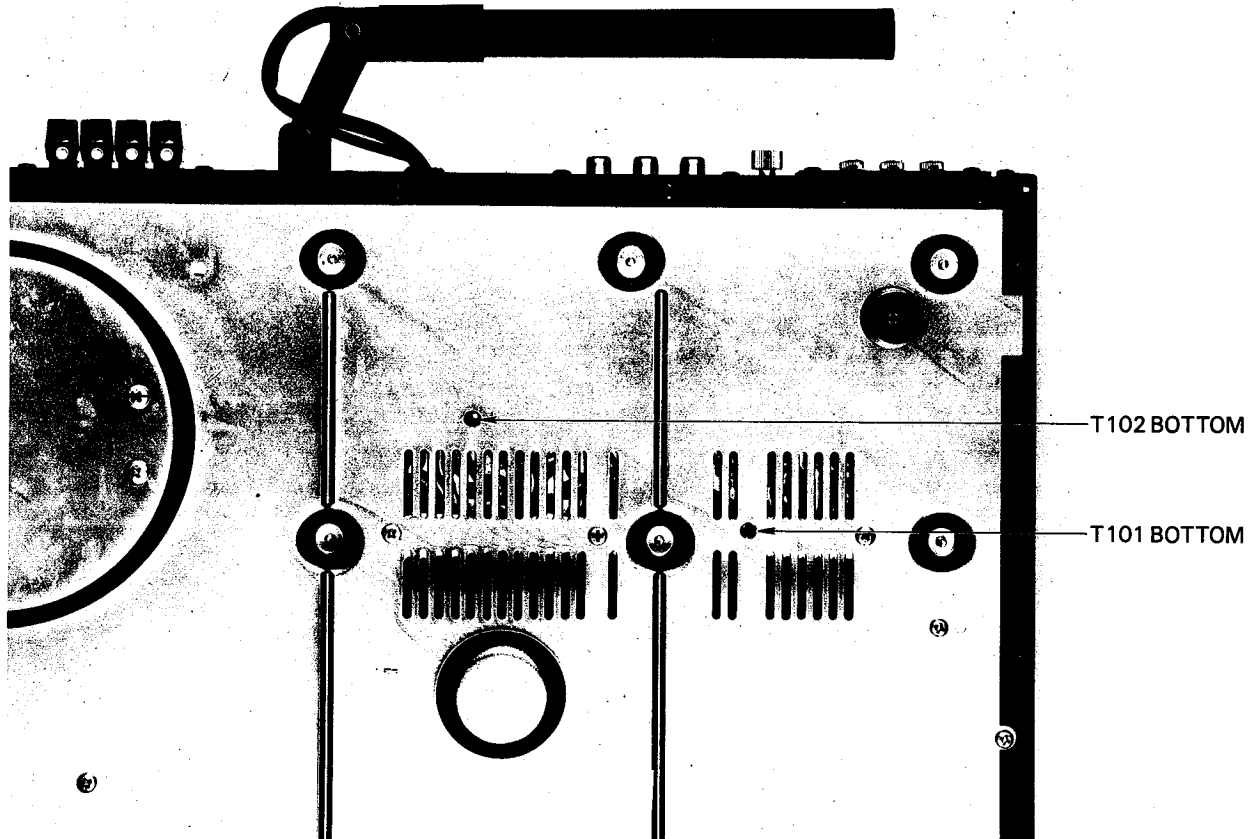

OR
undistorted Oscilloscope
balanced Oscilloscope
put on meter
output
e
e
e

WIRING DIAGRAM — MODEL 230e
MULTI-VOLTAGE

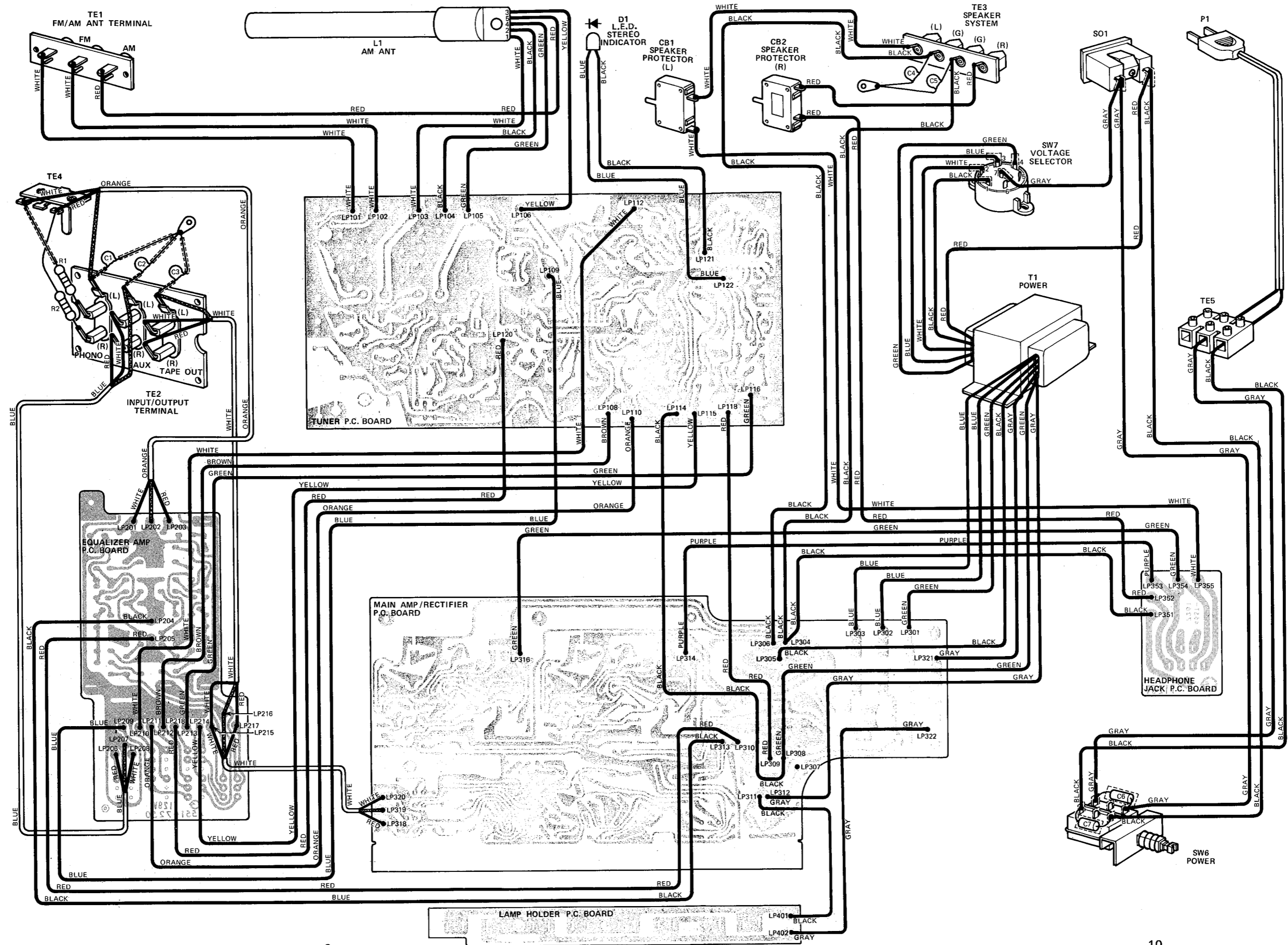

WIRING DIAGRAM – MODEL 230e MULTI-VOLTAGE

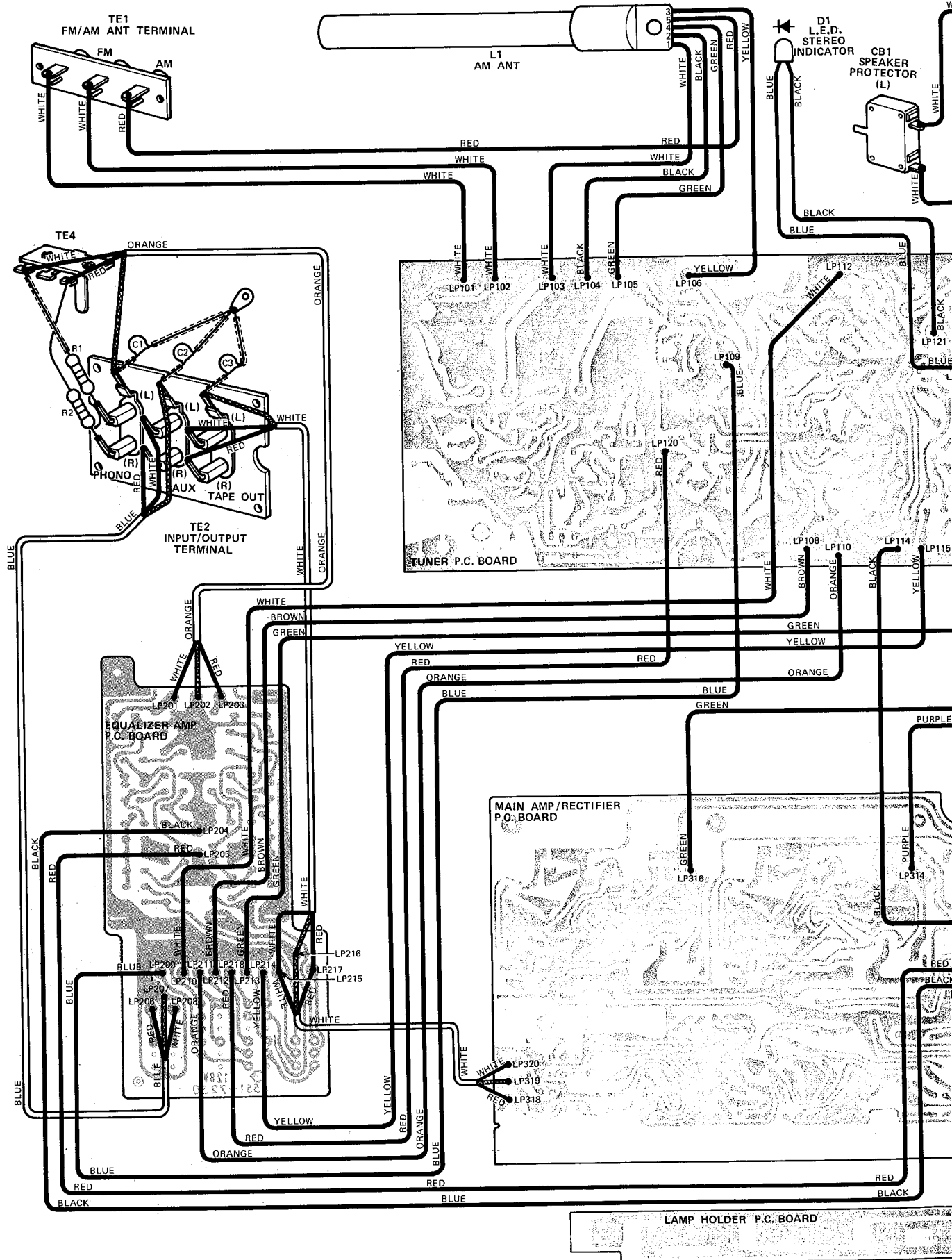

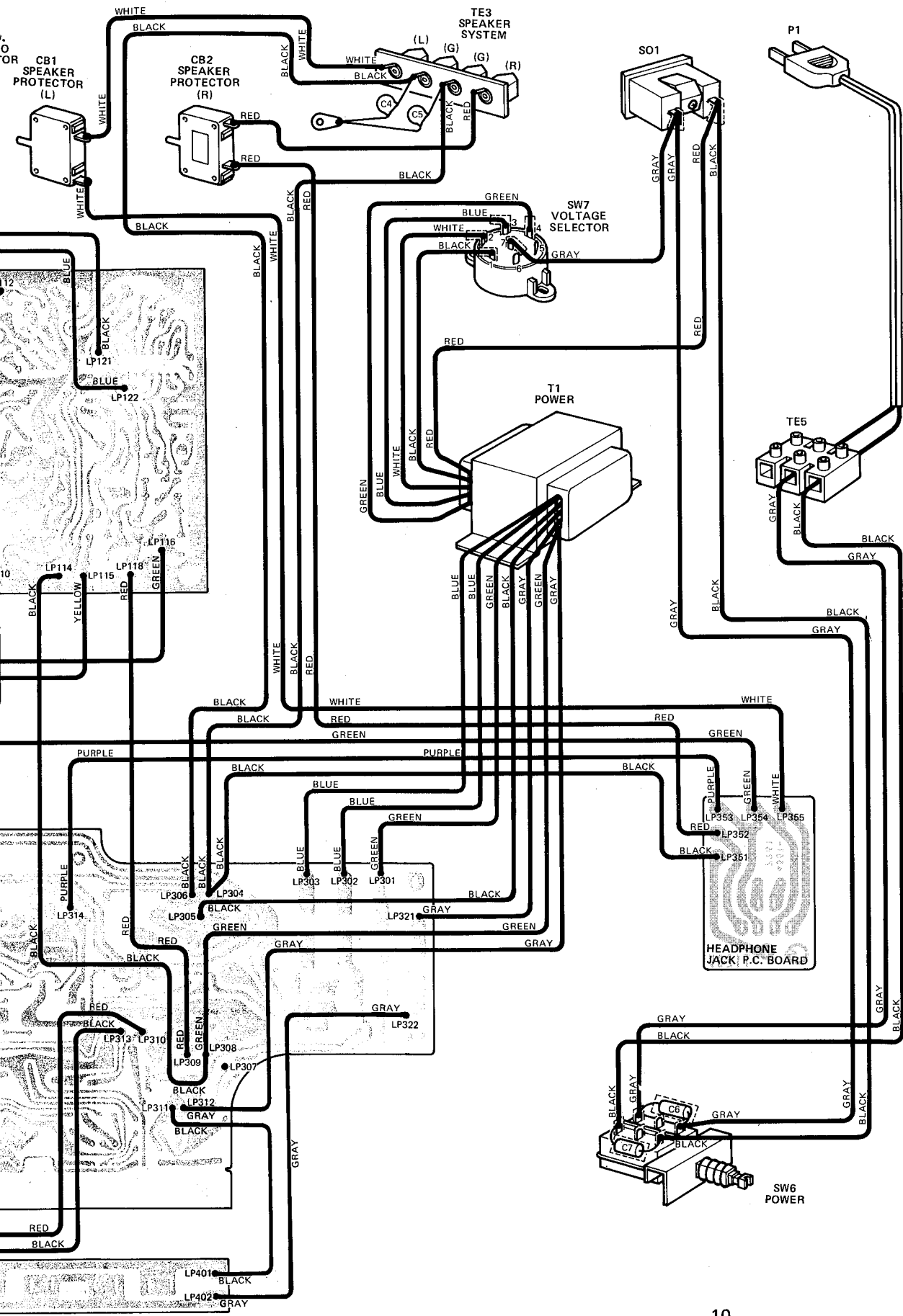

SCHEMATIC DIAGRAM — MODEL 230e
REGULAR VOLTAGE

FUNCTIONAL BLOCKS DIAGRAMS —

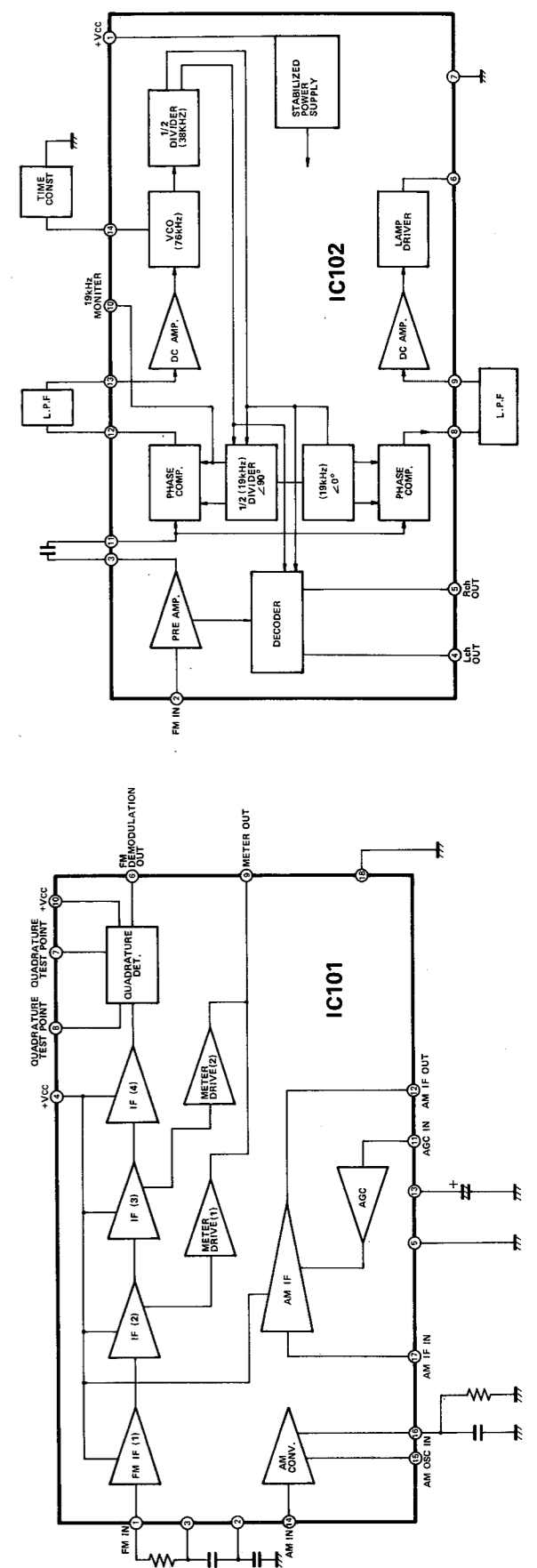
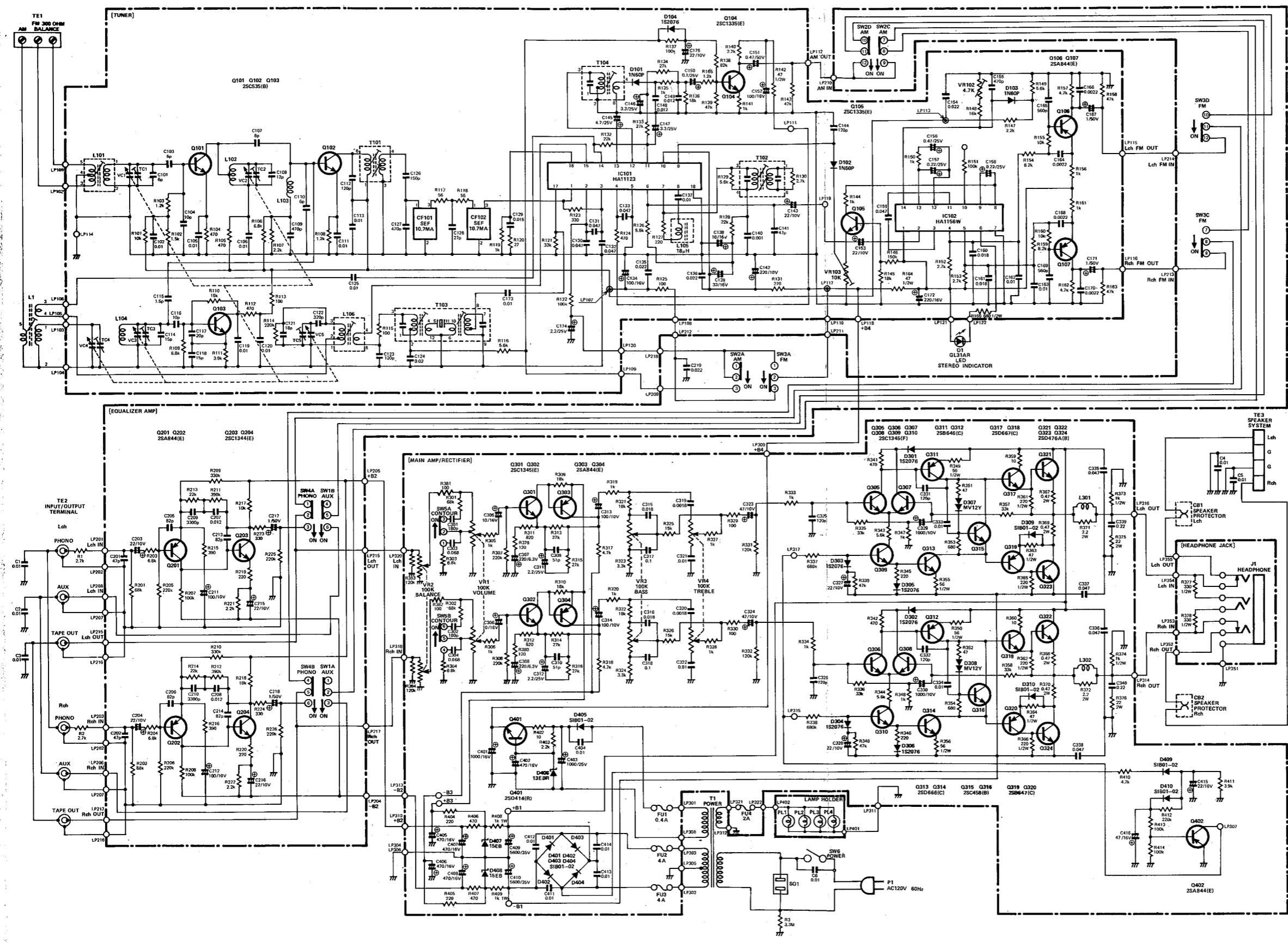

SCHEMATIC DIAGRAM – MODEL 230e REGULAR VOLTAGE

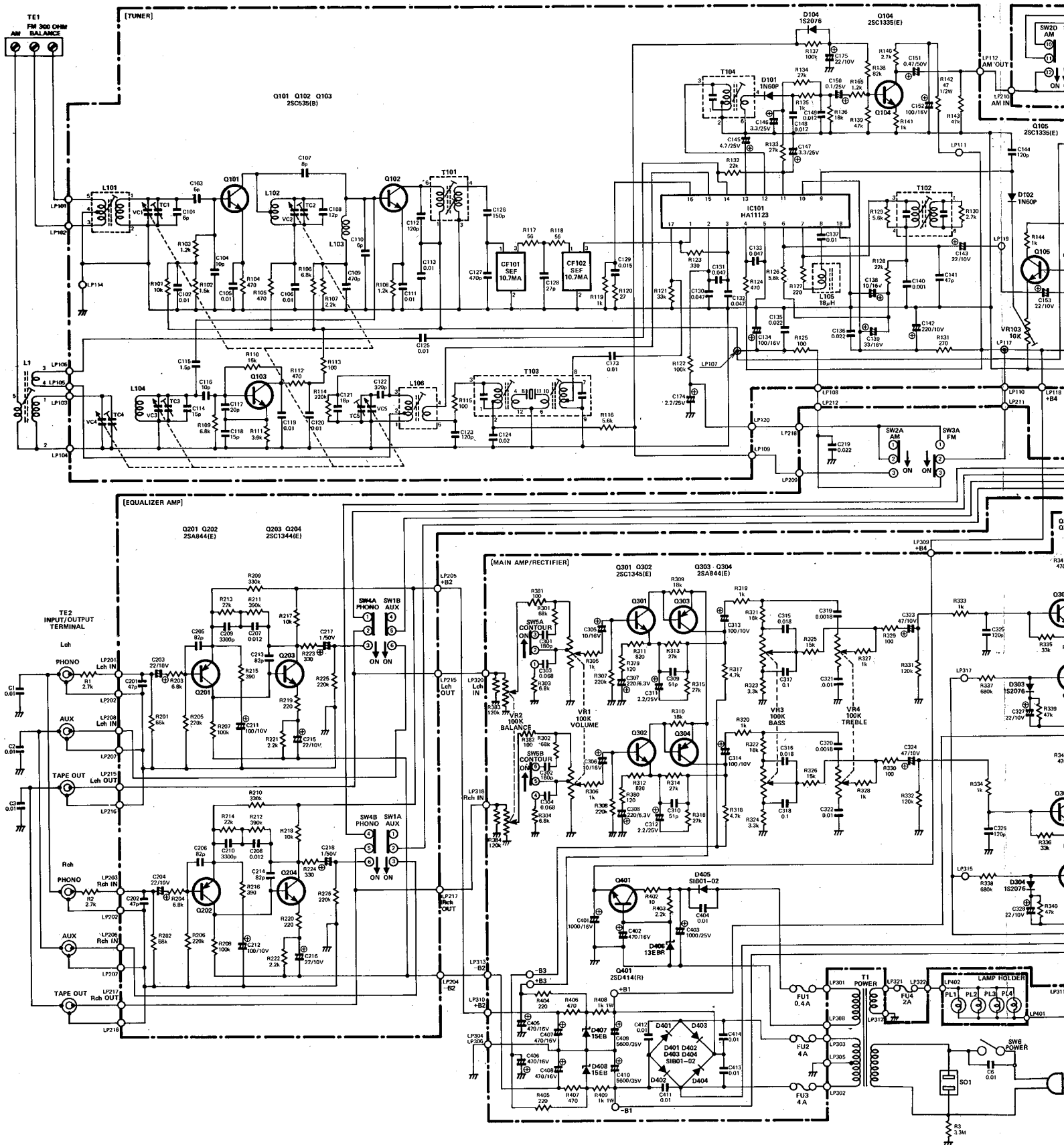

FUNCTIONAL BLOCKS DIAGRAMS -

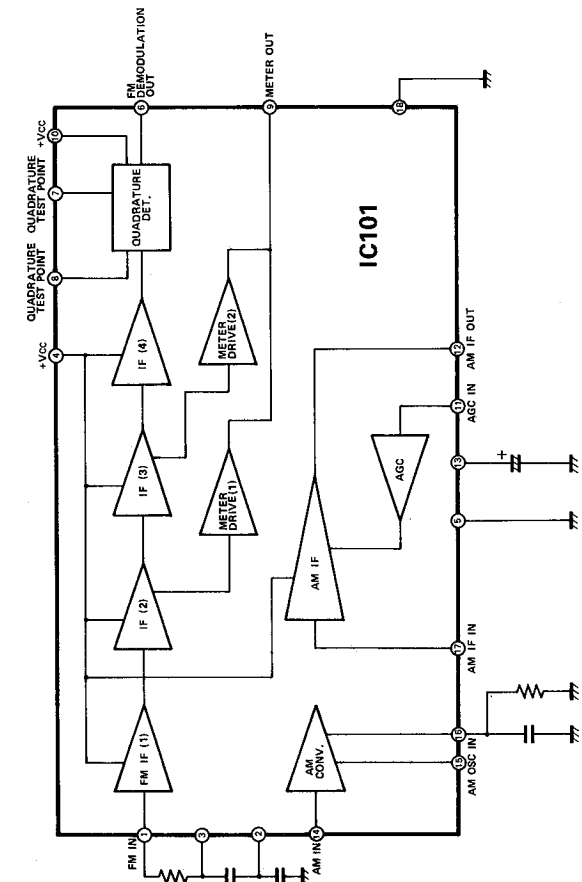
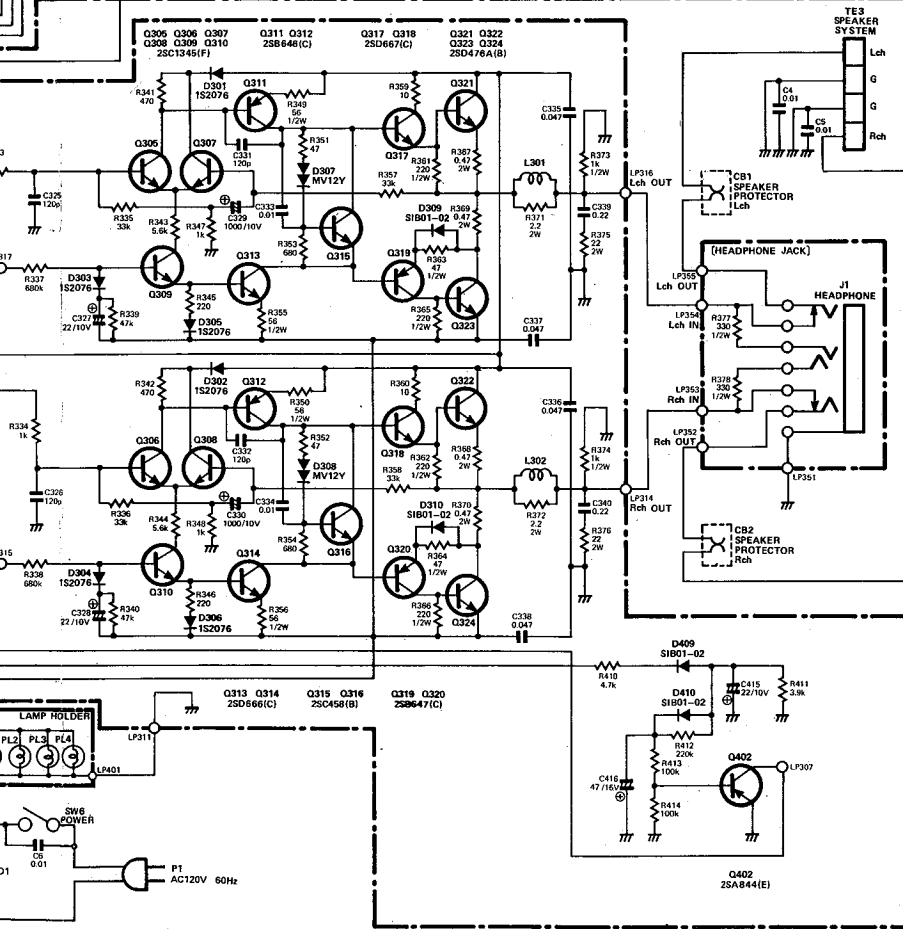
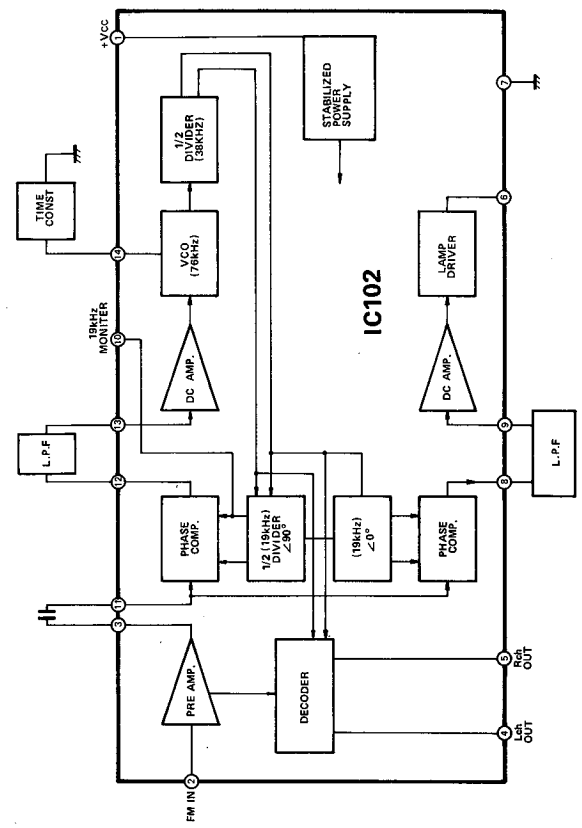
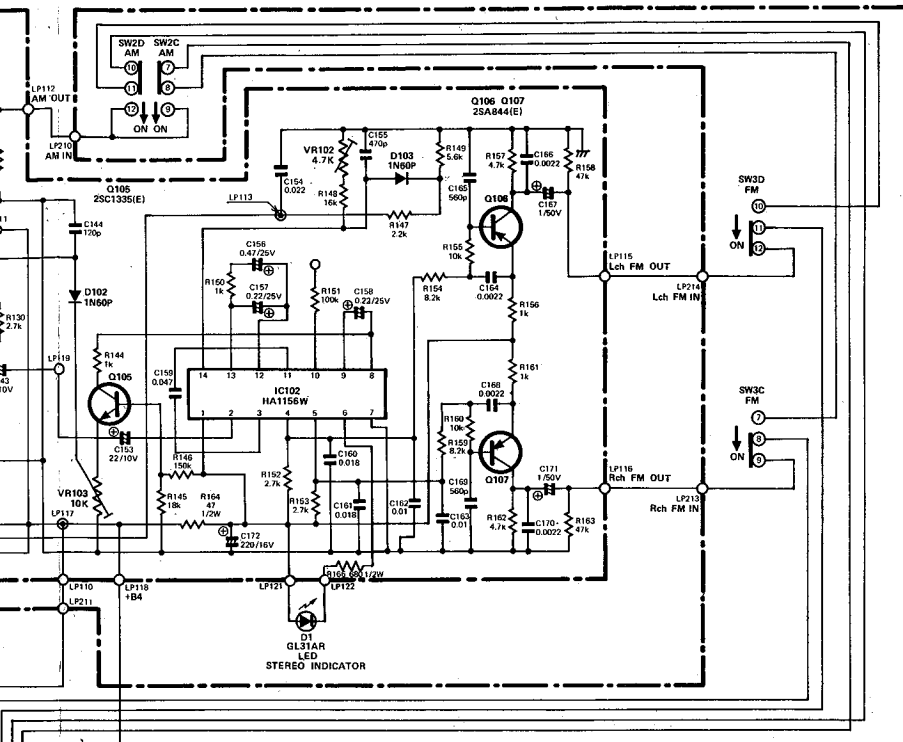

**SCHEMATIC DIAGRAM – MODEL 230e
MULTI-VOLTAGE**

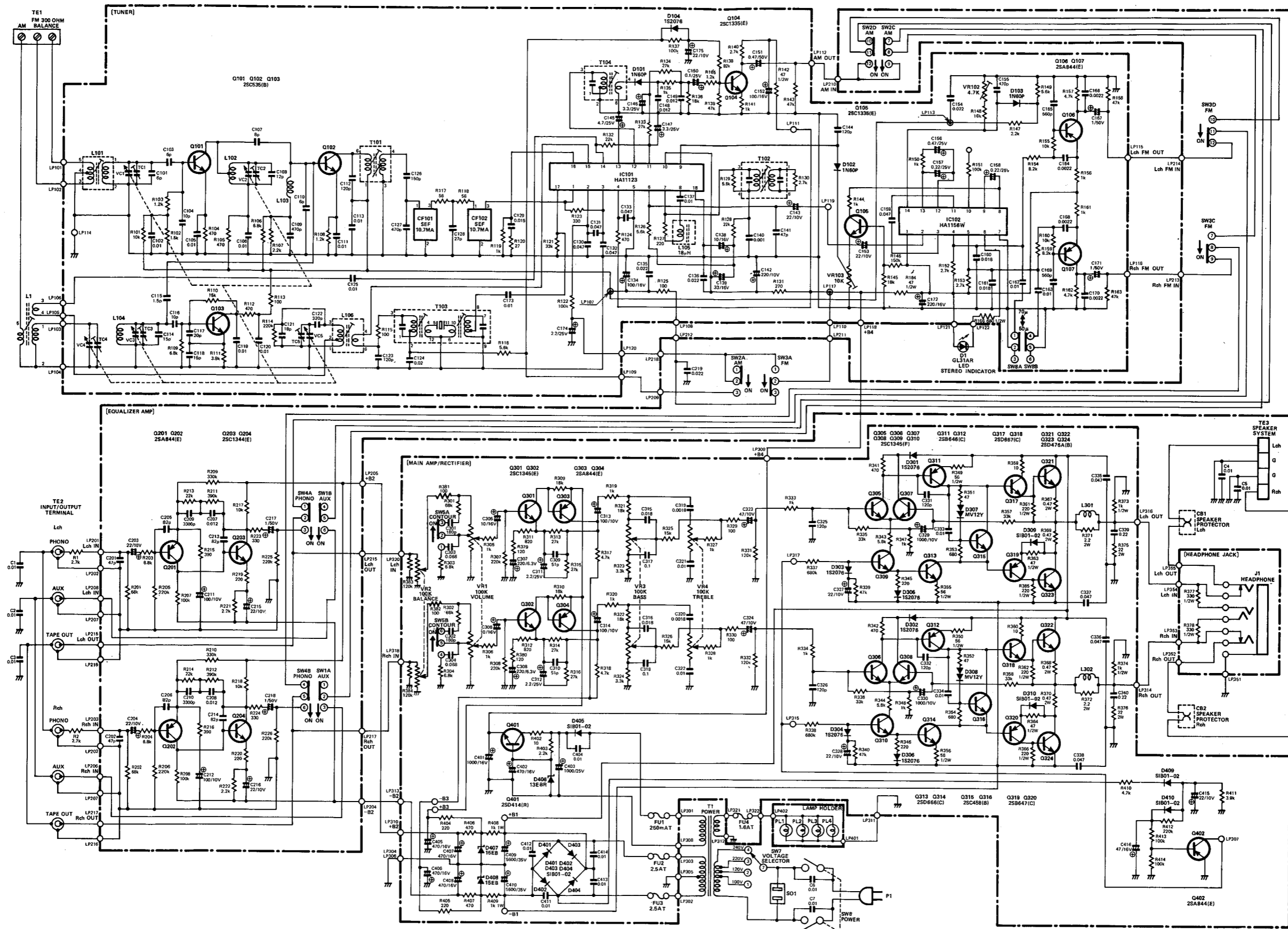

SCHEMATIC DIAGRAM – MODEL 230e MULTI-VOLTAGE

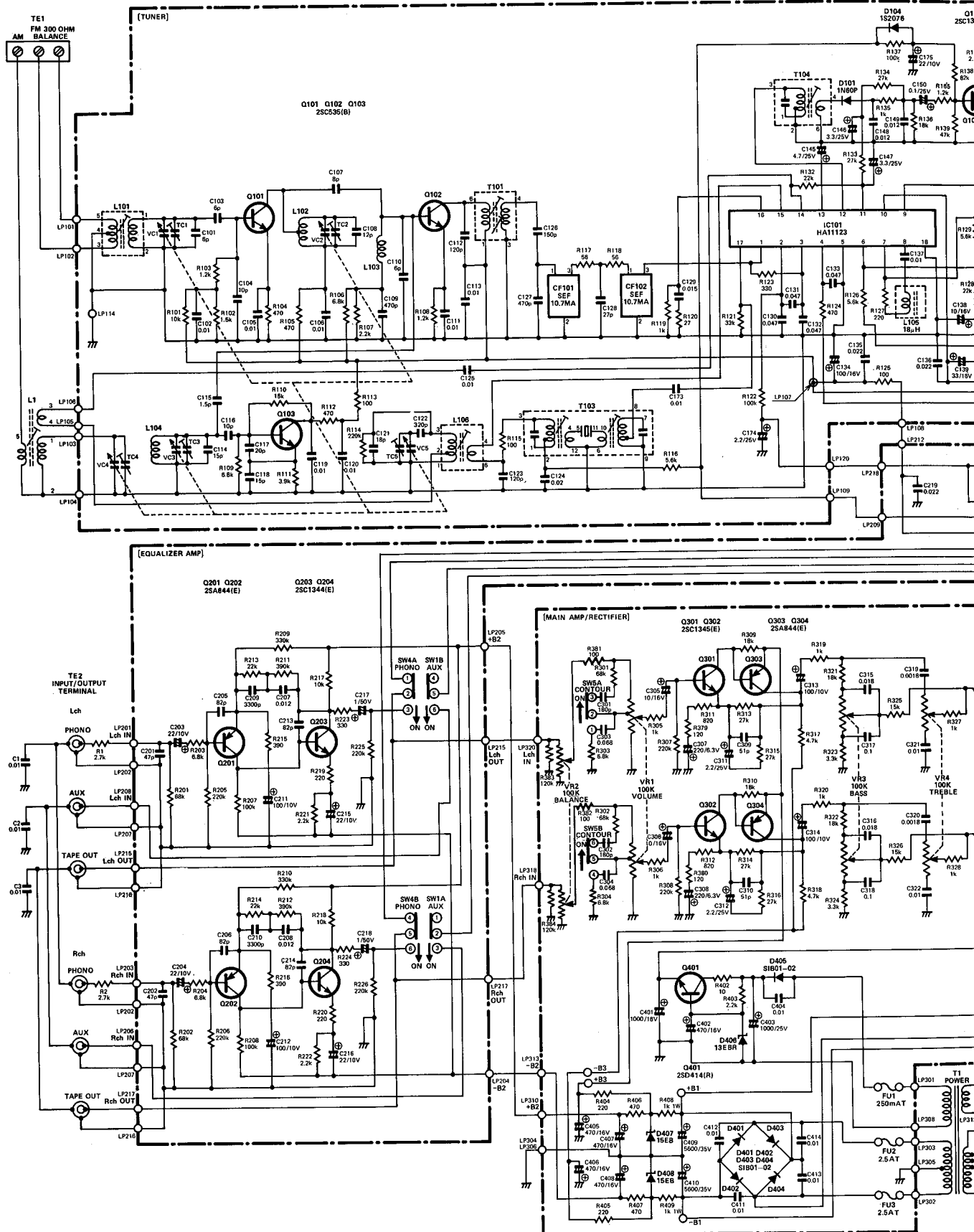

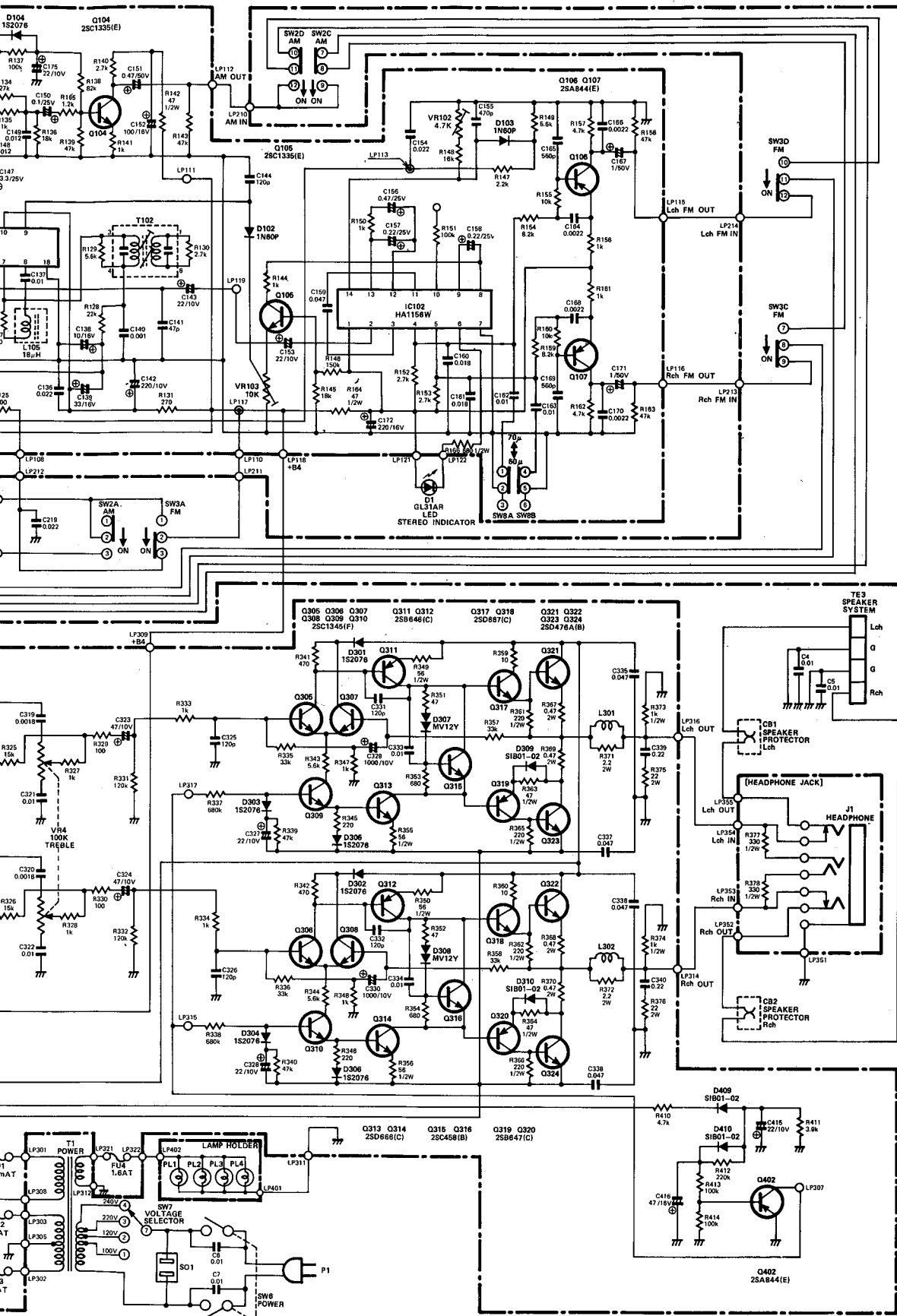

SCHEMATIC NOTES AND VOLTAGES

SCHEMATIC DIAGRAM NOTES

1. All resistors are 1/4 watt, ±5%, unless noted otherwise. Values are in ohms, K=1000 M=1000K
2. All capacitance values are in MF unless noted otherwise. PF=MMF
3. Function Selector switch (SW1-4) is in FM (SW3) position.

VOLTAGE CHART

AC 120V, Volume Control at Minimum, Tone Control at Mechanical Center, No Signal, Chassis Ground.

+B1 +26.6V	-B1 -26.6V
+B2 +13.6V	-B2 -13.6V
+B3 +13.7V	-B3 -13.7V
+B4 +12.2V		

FM POSITION			
	base	emitter	collector
Q101	+ 1.46V	+ 0.75V	+10.6V
Q102	+ 2.73V	+ 2.02V	+11.4V
Q103	+ 3.32V	+ 2.64V	+10.7V
Q105	+ 1.2V	+ 0.63V	+ 0.65V
Q106,107	+ 9.6V	+10.3V	+ 5.9V
Q201,202	+ 0.02V	+ 0.6V	- 9.8V
Q203,204	- 9.8V	-10.4V	+ 0.4V
Q301,302	- 0.03V	- 0.6V	+13.1V
Q303,304	+13.1V	+13.8V	- 1.6V
Q305,306	- 0.05V	- 0.6V	+25.4V
Q307,308	- 0.04V	- 0.6V	+26.3V
Q309,310	-24.9V	-25.6V	-18.8V
Q311,312	+25.4V	+26.1V	+ 1.2V
Q313,314	-25.6V	-26.2V	- 0.7V
Q315,316	- 0.01V	- 0.7V	+ 1.2V
Q317,318	+ 1.2V	+ 0.6V	+ 27V
Q319,320	- 0.7V	- 0.2V	-26.3V
Q321,322	+ 0.06V	+ 0.03V	+27V
Q323,324	-26.3V	-26.8V	- 0.01V
Q401	+12.8V	+12.2V	+19.3V
Q402	- 0.56V	0V	- 0.06V
AM POSITION			
Q104	+ 2.35V	+ 1.71V	+ 7.5V

IC101		IC102
FM	AM	FM
1. 4.2V	4.9V	1. 11.5V
2. 4.1V	5.1V	2. 3.1V
3. 4.1V	4.9V	3. 5.9V
4. 6.6V	6.6V	4. 9.6V
5. 0V	0V	5. 9.6V
6. 4.5V	4.7V	6. ---
7. 4.6V	4.7V	7. 0V
8. 6.4V	6.7V	8. 0.7V
9. 0.02V	0.02V	9. 2.4V
10. 7.4V	7.7V	10. 1.6V
11. 0.5V	0.95V	11. 2.3V
12. 0.006V	0.005V	12. 2.4V
13. 5.1V	4.3V	13. 2.4V
14. 0.7V	1.4V	14. 3.3V
15. 0.06V	6.7V	
16. 0.06V	1.0V	
17. 0.75V	0.75V	
18. 0V	0V	

TUNER PC BOARD

CIRCUIT REF NO.	H/K PART NO.	DESCRIPTION
	00135023A	PC BD Assy Tuner
RESISTOR		
R148	35211633	Fixed, Metal 16K, ±1%, 1/4W
VR102	23530554	Variable 4.7K
VR103	23534830A	Variable 10K
CAPACITOR		
VC1,2,3,4,5	30834831A	5 Gang Variable w/TC1,2,4,5, Variable, Trimmer
TC3	30934832A	
CERAMIC FILTER		
CF1,2	12030549	FM IF, 10.7MHz
T103	12034833A	AM IF, 455KHz
TRANSISTOR		
Q101,102,103	43034834A*	2SC535(B) FM RF Amp, FM Mixer, FM Osc.
Q104,105	43030569*	2SC1335(E) AM Demod Sig Amp, Stereo/Mono-Switching
Q106,107	43031312*	2SA844(E) MPX Output AMP
DIODE		
D101,102,103	41034873A*	IN60
D104	41030552*	1S2076
INTEGRATED CIRCUIT		
IC101	43134835A*	HA11123 FM IF AMP/ FM DET/AM Converter/ AM IF AMP
IC102	43132131*	HA1156W MPX
COIL		
L101	12034836A	Matching
L102	12034837A	FM RF
L103	12034838A	IF Trap
L104	12034839A	FM OSC
L105	12034840A	Phase Shifter, 18μH
L106	12031316	AM OSC
TRANSFORMER		
T101	11034841A	FM IF
T102	11034842A	Quadrature Detector
T104	11034843A	AM IF

SCHEMATIC NOTES AND VOLTAGES

TUNE

SCHEMATIC DIAGRAM NOTES

1. All resistors are 1/4 watt, $\pm 5\%$, unless noted otherwise.
Values are in ohms, K=1000 M=1000K
2. All capacitance values are in MF unless noted otherwise. PF=MMF
3. Function Selector switch (SW1-4) is in FM (SW3) position.

VOLTAGE CHART

AC 120V, Volume Control at Minimum, Tone Control at Mechanical Center, No Signal, Chassis Ground.

+B1	+26.6V	-B1	-26.6V
+B2	+13.6V	-B2	-13.6V
+B3	+13.7V	-B3	-13.7V
+B4	+12.2V			

FM POSITION			
	base	emitter	collector
Q101	+ 1.46V	+ 0.75V	+10.6V
Q102	+ 2.73V	+ 2.02V	+11.4V
Q103	+ 3.32V	+ 2.64V	+10.7V
Q105	+ 1.2V	+ 0.63V	+ 0.65V
Q106,107	+ 9.6V	+10.3V	+ 5.9V
Q201,202	+ 0.02V	+ 0.6V	- 9.8V
Q203,204	- 9.8V	-10.4V	+ 0.4V
Q301,302	- 0.03V	- 0.6V	+13.1V
Q303,304	+13.1V	+13.8V	- 1.6V
Q305,306	- 0.05V	- 0.6V	+25.4V
Q307,308	- 0.04V	- 0.6V	+26.3V
Q309,310	-24.9V	-25.6V	-18.8V
Q311,312	+25.4V	+26.1V	+ 1.2V
Q313,314	-25.6V	-26.2V	- 0.7V
Q315,316	- 0.01V	- 0.7V	+ 1.2V
Q317,318	+ 1.2V	+ 0.6V	+ 27V
Q319,320	- 0.7V	- 0.2V	-26.3V
Q321,322	+ 0.06V	+ 0.03V	+27V
Q323,324	-26.3V	-26.8V	- 0.01V
Q401	+12.8V	+12.2V	+19.3V
Q402	- 0.56V	0V	- 0.06V
AM POSITION			
Q104	+ 2.35V	+ 1.71V	+ 7.5V

IC101		IC102
FM	AM	FM
1. 4.2V	4.9V	1. 11.5V
2. 4.1V	5.1V	2. 3.1V
3. 4.1V	4.9V	3. 5.9V
4. 6.6V	6.6V	4. 9.6V
5. 0V	0V	5. 9.6V
6. 4.5V	4.7V	6. -----
7. 4.6V	4.7V	7. 0V
8. 6.4V	6.7V	8. 0.7V
9. 0.02V	0.02V	9. 2.4V
10. 7.4V	7.7V	10. 1.6V
11. 0.5V	0.95V	11. 2.3V
12. 0.006V	0.005V	12. 2.4V
13. 5.1V	4.3V	13. 2.4V
14. 0.7V	1.4V	14. 3.3V
15. 0.06V	6.7V	
16. 0.06V	1.0V	
17. 0.75V	0.75V	
18. 0V	0V	

TUNER PC BOARD

CIRCUIT REF NO.	H/K PART NO.	DESCRIPTION
	00135023A	PC BD Assy Tuner
RESISTOR		
R148	35211633	Fixed, Metal 16K, ±1%, 1/4W
VR102	23530554	Variable 4.7K
VR103	23534830A	Variable 10K
CAPACITOR		
VC1,2,3,4,5	30834831A	5 Gang Variable w/TC1,2,4,5,
TC3	30934832A	Variable, Trimmer
CERAMIC FILTER		
CF1,2	12030549	FM IF, 10.7MHz
T103	12034833A	AM IF, 455KHz
TRANSISTOR		
Q101,102,103	43034834A *	2SC535(B) FM RF Amp, FM Mixer, FM Osc.
Q104,105	43030569*	2SC1335(E) AM Demod Sig Amp, Stereo/Mono-Switching
Q106,107	43031312*	2SA844(E) MPX Output AMP
DIODE		
D101,102,103	41034873A *	IN60
D104	41030552*	1S2076
INTEGRATED CIRCUIT		
IC101	43134835A *	HA11123 FM IF AMP/ FM DET/AM Converter/ AM IF AMP
IC102	43132131*	HA1156W MPX
COIL		
L101	12034836A	Matching
L102	12034837A	FM RF
L103	12034838A	IF Trap
L104	12034839A	FM OSC
L105	12034840A	Phase Shifter, 18μH
L106	12031316	AM OSC
TRANSFORMER		
T101	11034841A	FM IF
T102	11034842A	Quadrature Detector
T104	11034843A	AM IF

TUNER PC BOARD

REGULAR VOLTAGE

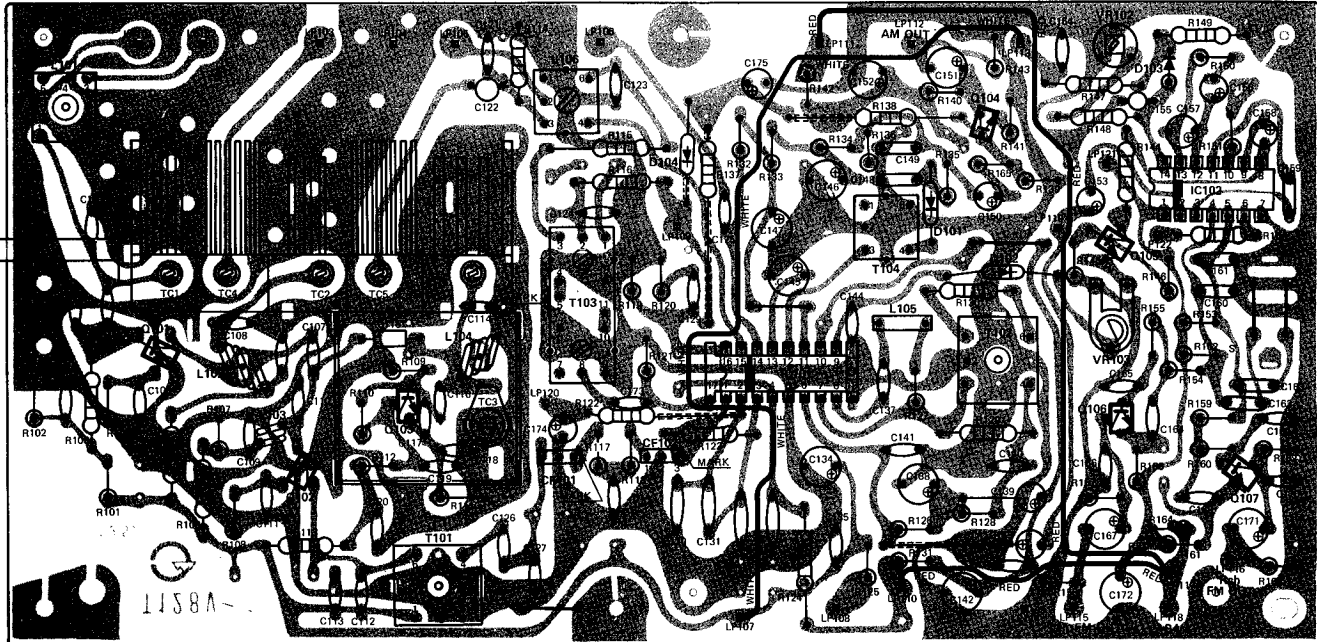

MULTI-VOLTAGE

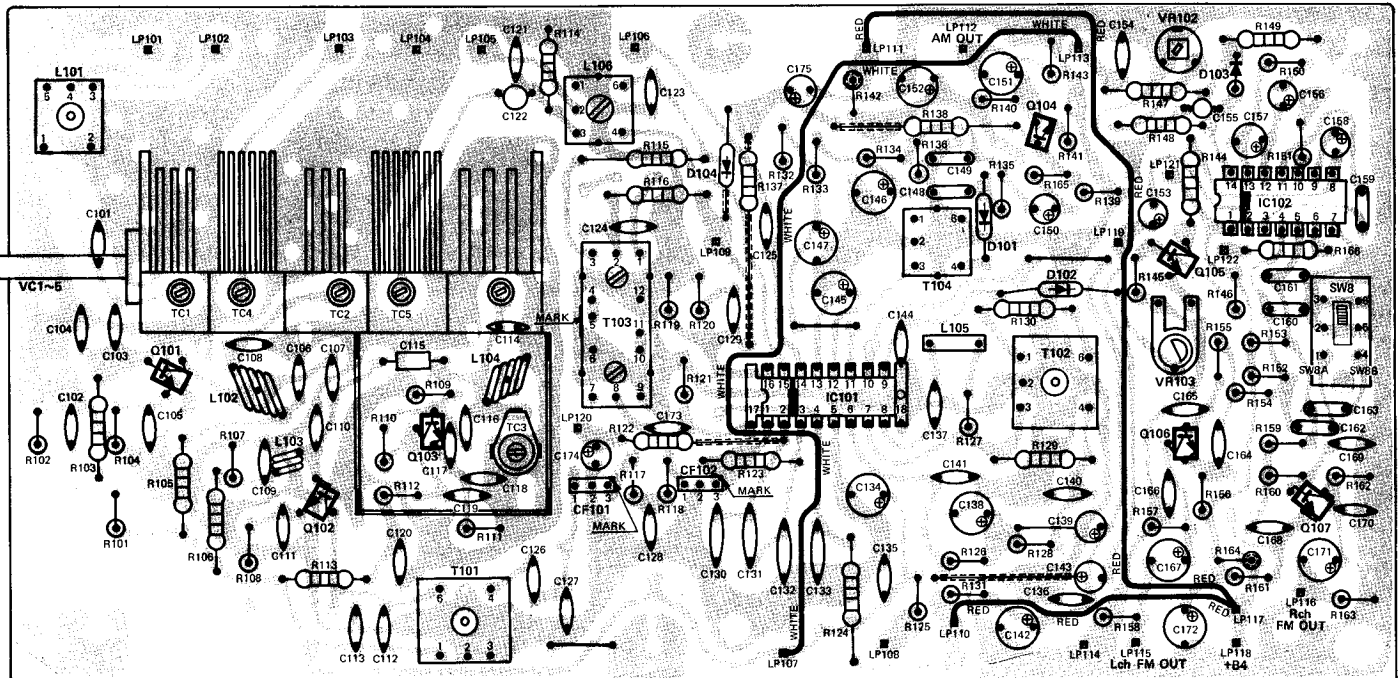

MAIN AMP RECTIFIER PC BOARD

CIRCUIT REF NO.	H/K PART NO.	DESCRIPTION
	00135022A	PC BD Assy Main Amp/Rectifier
RESISTOR		
R359,360	33211005	Fixed, Fuse 10 ohm, 1/4W
R367,368,369,370	33514781	Fixed, Wirewound, Cement 0.47 ohm, 2W
R375,376	33512201	Fixed, Wirewound, Cement 22 ohm, 2W
R402	35211005	Fixed, Metal 10 ohm, 5%, 1/4W
VR1,2	23535032A	Variable, 100K, Volume & Balance Control
VR3,4	23534846A	Variable, 100K, Bass & Treble Control
CAPACITOR, LYTIC		
C401	31828610	1000 UF +50-10% 16V
C402	31828611	470 UF +50-10% 16V
C403	31828613	100 UF +50-10% 25V
C409,410	31834952A	5600 UF +50-10% 35V
C415	31831322	22 UF +50-10% 10V
C416	31819155	47 UF +50-10% 10V
TRANSISTOR		
Q301,302	43033345*	2SC1345(E) Pre Amp
Q303,304	43031312*	2SA844(E) Pre Amp
Q305,306,307,308	43034872A*	2SC1345(F) Differential Amp
Q309,310	43034872A*	2SC1345(F) Current Regulator
Q311,312	43034847A*	2SB646(C) Driver
Q313,314	43034848A*	2SD666(C) Current Regulator
Q315,316	43034968A*	2SC458(B) Bias Stabilization
Q317,318	43034849A*	2SD667(C) Complement
Q319,320	43034850A*	2SB647(C) Complement
Q321,322,323,324	43032753*	2SD476A(B) Power Amp
Q401	43032759*	2SD414(Q) or (R) Voltage Rectifier
Q402	43031312*	2SA844(E) Muting
DIODE		
D301,302,303,304, 305,306	41030552*	1S2076
D307,308	41631340*	MV12Y
D309,310,401,402, 403,404,405,409, 410	41631295*	SIB01-02
D406	42032760*	Zener, RD13EB
D407,408	42032757*	Zener, RD15EB
MISCELLANEOUS		
L301,302	12034851A	RF Choke
FU1	45034852A*	Fuse, 0.4A, 250V
FU2,3	45031462*	Fuse, 4A, 250V
FU4	45032129*	Fuse, 2A, 250V
SW5	25034853A	Switch, Push, Contour
MULTI-VOLTAGE		
FU1	45234870*	Fuse, Slo-Blo, 250mA, 250V
FU2,3	45234420V*	Fuse, Slo-Blo, 2.5AT, 250V
FU4	45234420T*	Fuse, Slo-Blo, 1.6AT, 250V

MAIN AMP RECTIFIER
PC BOARD

REGULAR VOLTAGE

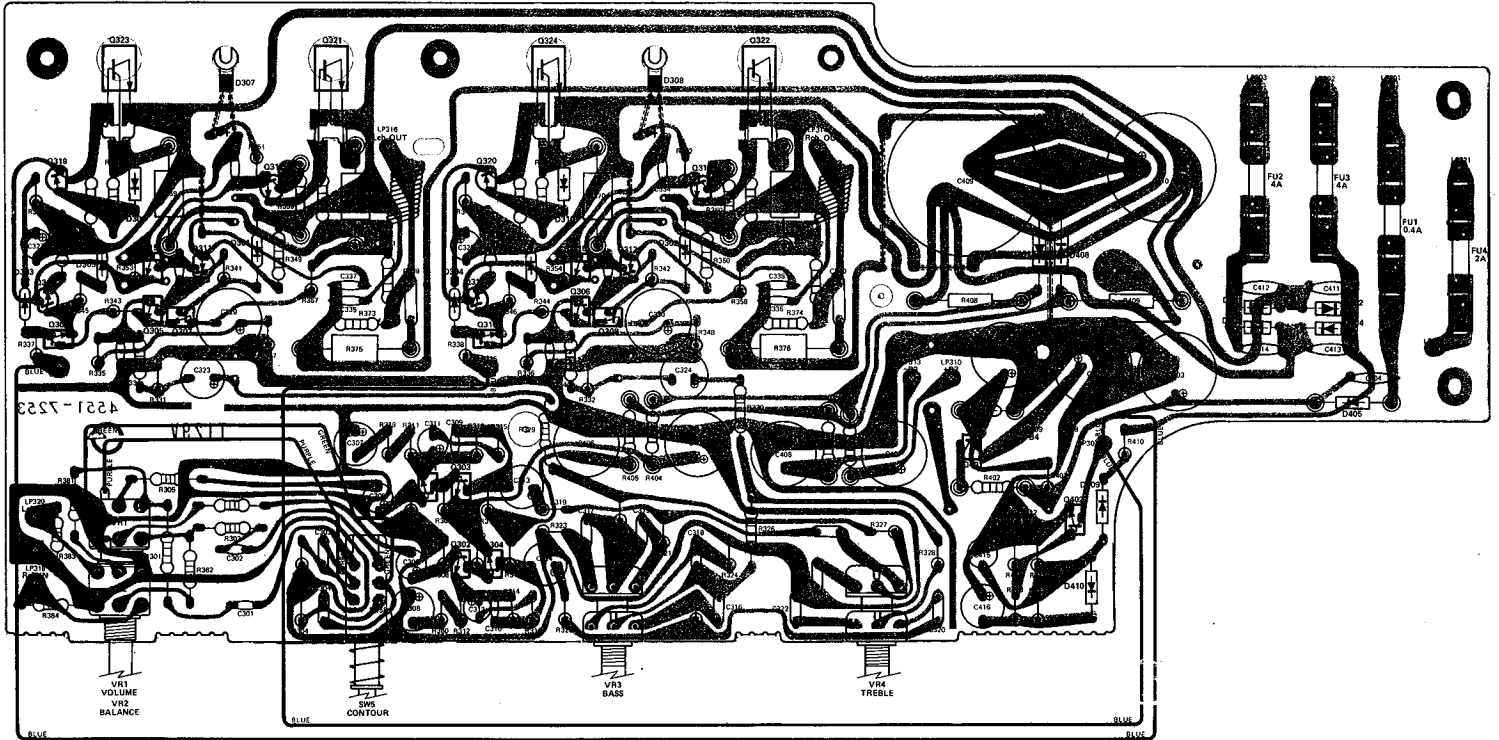

MULTI-VOLTAGE

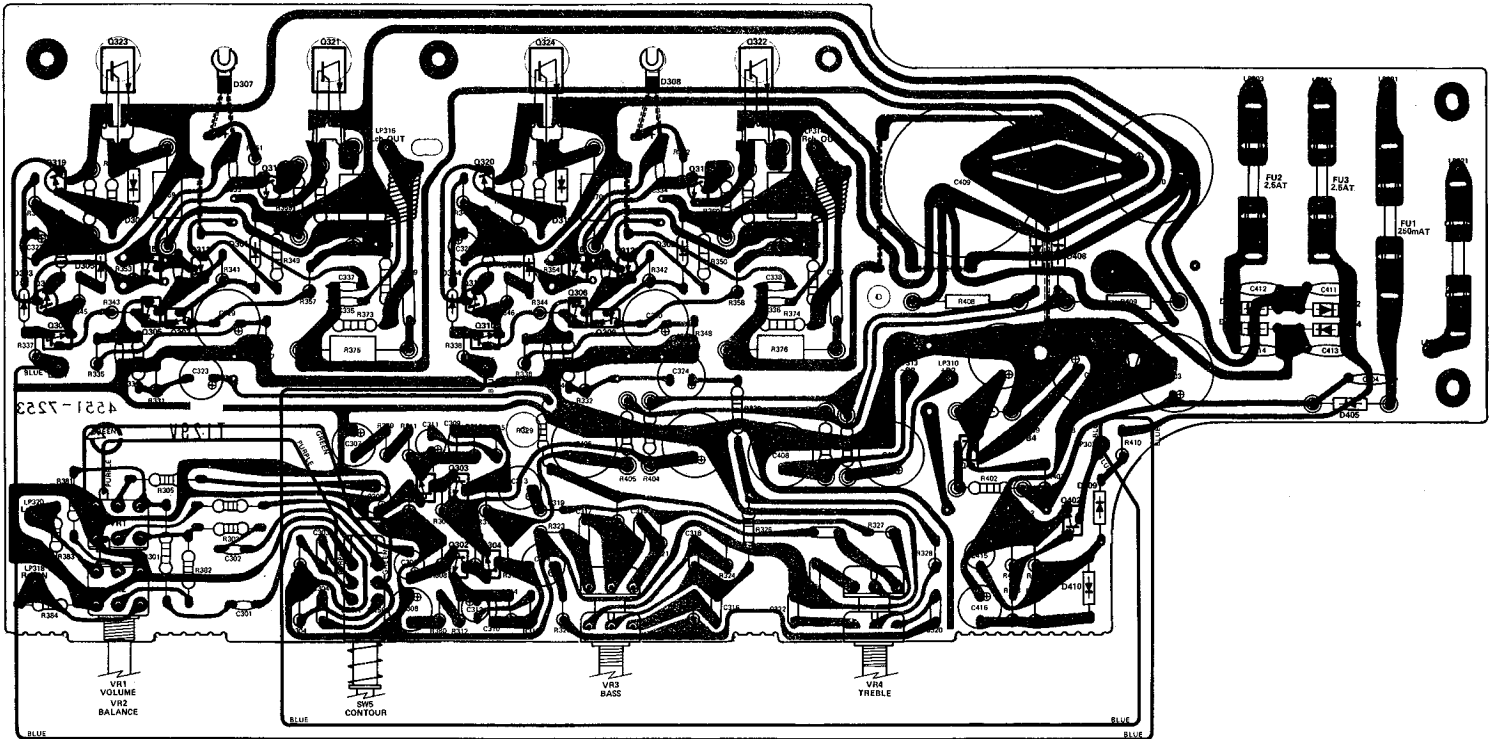

EQUALIZER AMP PC BOARD

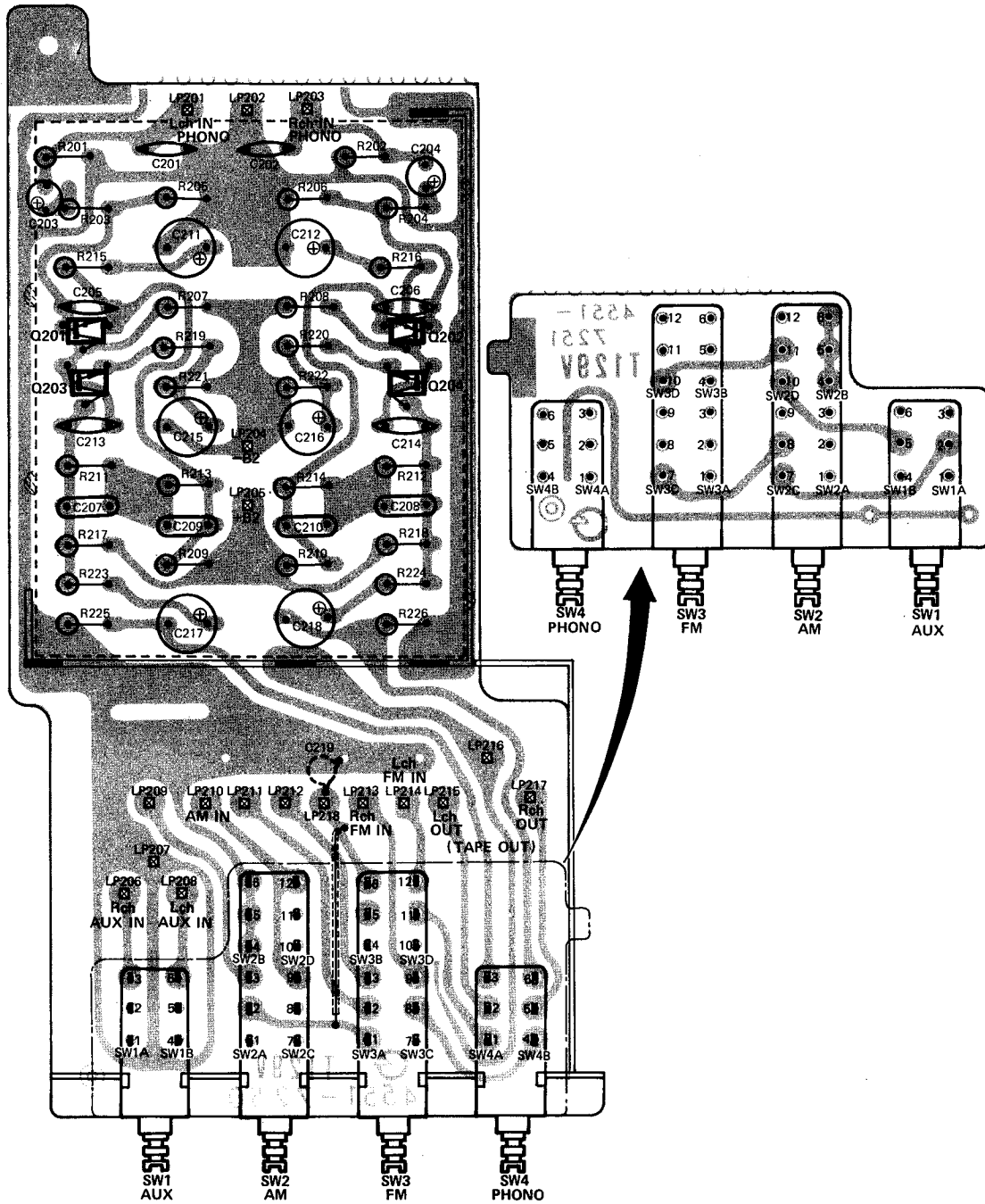

CIRCUIT REF NO.	H/K PART NO.	DESCRIPTION
	00135024A	PC BD Assy Equalizer Amp
TRANSISTOR		
Q201,202	43031312*	2SA844(E) Equalizer Amp
Q203,204	43028535*	2SC1344(E) Equalizer Amp
SWITCH		
SW1,2,3,4	25034844A	Push, 4 Gang, Aux, AM, FM, Phono

LAMPHOLDER PC BOARD

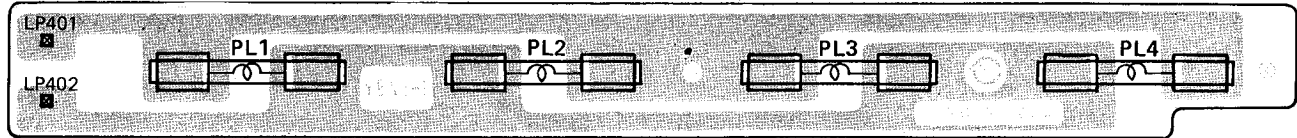

CIRCUIT REF NO.	H/K PART NO.	DESCRIPTION
	00135027A	PC BD Assy Lamp Holder
PL1,2,3,4	46535026A* 66035035A	Lamp, 7V, 260mA Lamp Holder (X8)

HEADPHONE JACK PC BOARD

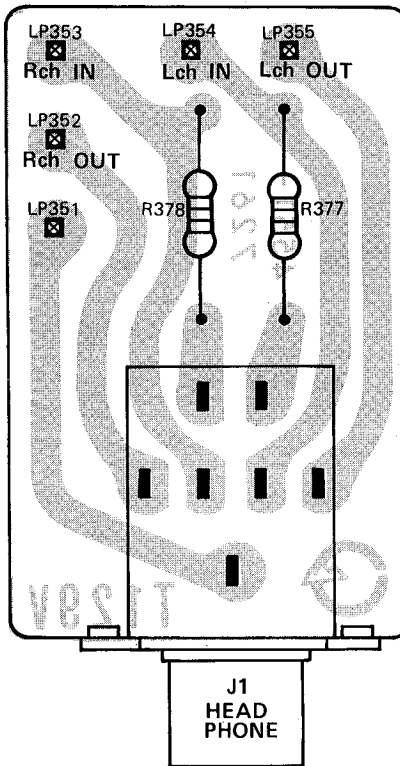

CIRCUIT REF NO.	H/K PART NO.	DESCRIPTION
	00135057A	PC BD Assy, Headphone Jack
J1	65434854A	Headphone Jack

CHASSIS PARTS LIST

CIRCUIT REF NO.	H/K PART NO.	DESCRIPTION
1	00234855A	Knob Assy, Tuning
2	00234857A	Tuning Shaft Assy
3	00234856A	Dial Pointer Assy (incl Led D1)
4	63235034A	Knob Assy, Volume
5	63235028A	Knob, Balance
6	63235029A	Knob, Bass/Treble
7	63234863A	Pushbutton Knob, Power
8	63234864A	Pushbutton Knob, Phono/FM/ AM/AUX/Contour
9	61034859A	Front Panel, Black
10	61034860A	Front Panel, Smoke
11	61035033A	Dial Scale
12	60134865A	Cover, Top
13	62031373	Foot, Rubber (X4)
14	60431387	Dial Drum
15	61631381	AM Ferrite Bar Antenna Holder
16	60433334	Pulley, Dial Cord
MISCELLANEOUS		
	00135022A	PC BD Assy, Main Amp/Rectifier
	00135023A	PC BD Assy, Tuner
	00135024A	PC BD Assy, Equalizer Amp
	00135057A	PC BD Assy, Headphone Jack
	00135027A	PC BD Assy, Lamp Holder
ELECTRICAL		
	<i>10134821</i>	<i>RU XFMR - 5584-701178, 5584-703178</i>
T1	10135025A	Transformer, Power
SO1	65431485	Ext AC Socket, Switched
SW6	25032117*	Switch, Pushbutton, Power
TE1	65129518	Terminal, FM/AM Ext Antenna
TE2	65434822A	Jack, 6 Pin, Phono/Aux/Tape Output
TE3	65434823A	Terminal, Speaker Output
CB1, CB2	44534825A*	Circuit Breaker, Speakers
D1	46734827A*	L.E.D., GL31AR, Stereo Indicator
L1	20534828A	AM Ferrite Bar Antenna
MULTI-VOLTAGE RECEIVER		
	00134030A	PC BD Assy, Main Amp/Rectifier
	00135031A	PC BD Assy, Tuner
T1	10135036A	Transformer, Power
SW6	25033336	Switch, Pushbutton, Power
SW7	24031338	Switch, Rotary, Power Source Voltage Selector
SW8	24531335	Switch, Slide (On Tuner PC BD)

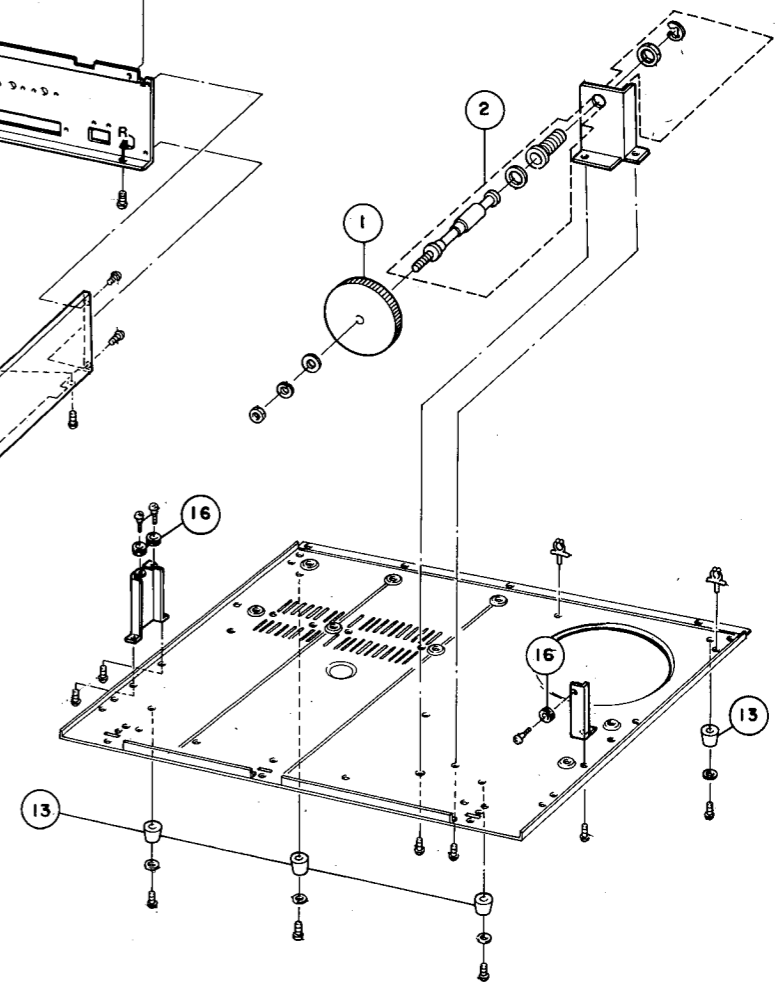
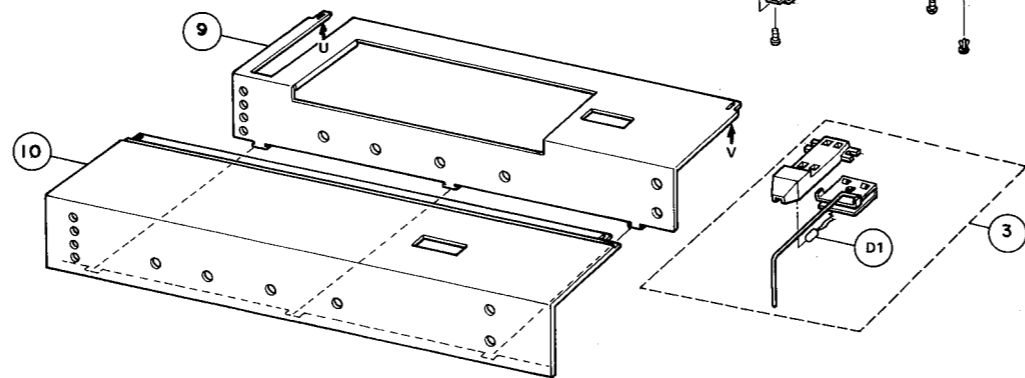
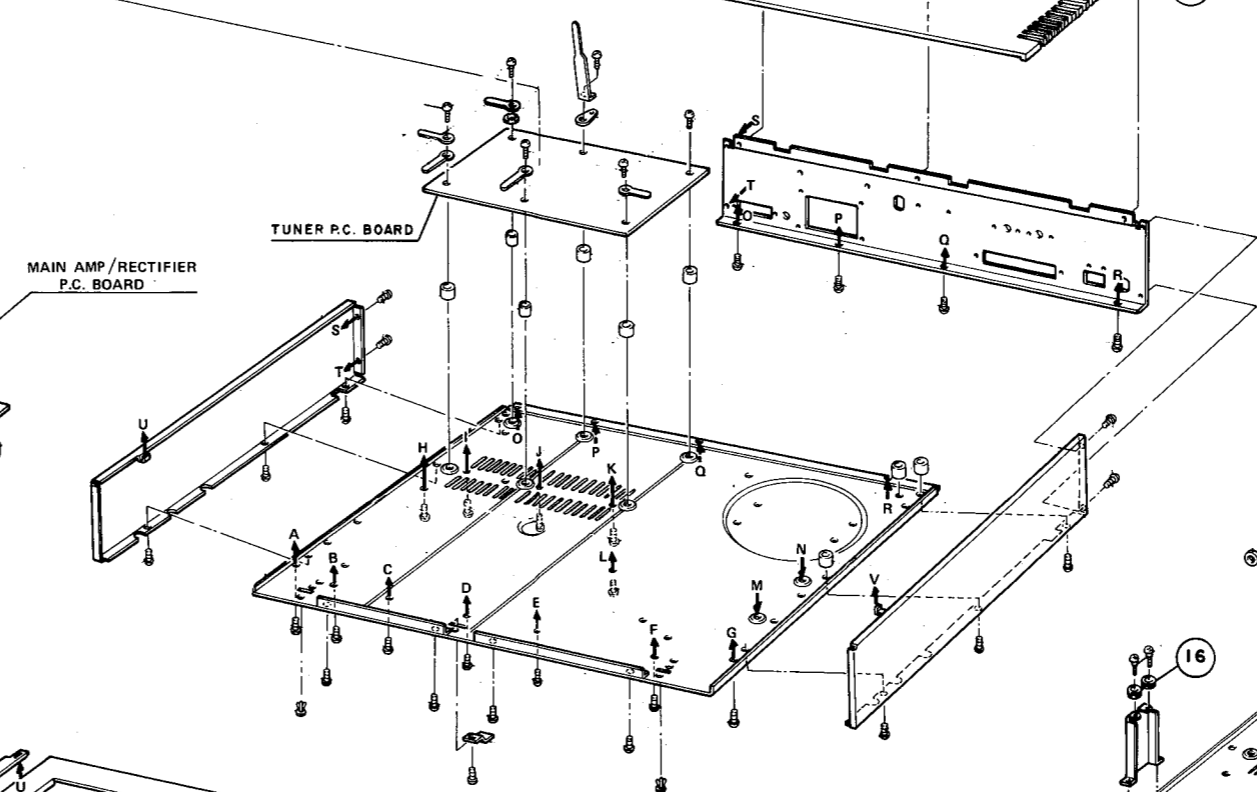
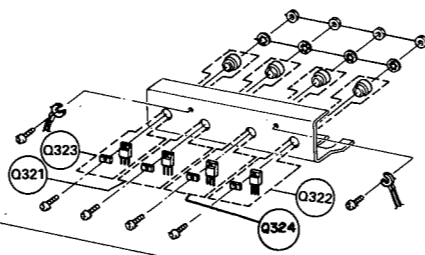
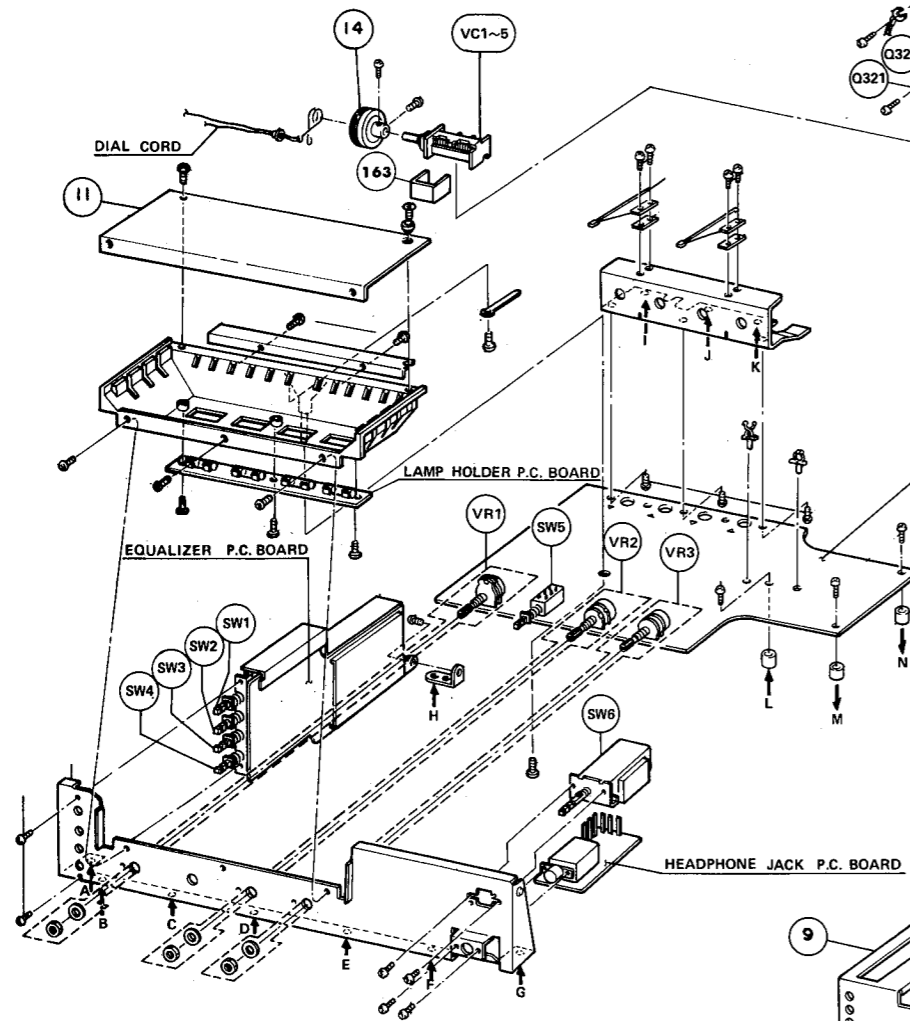
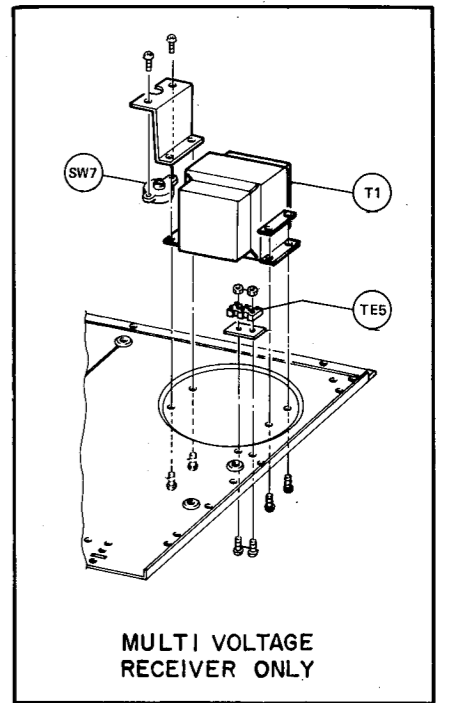
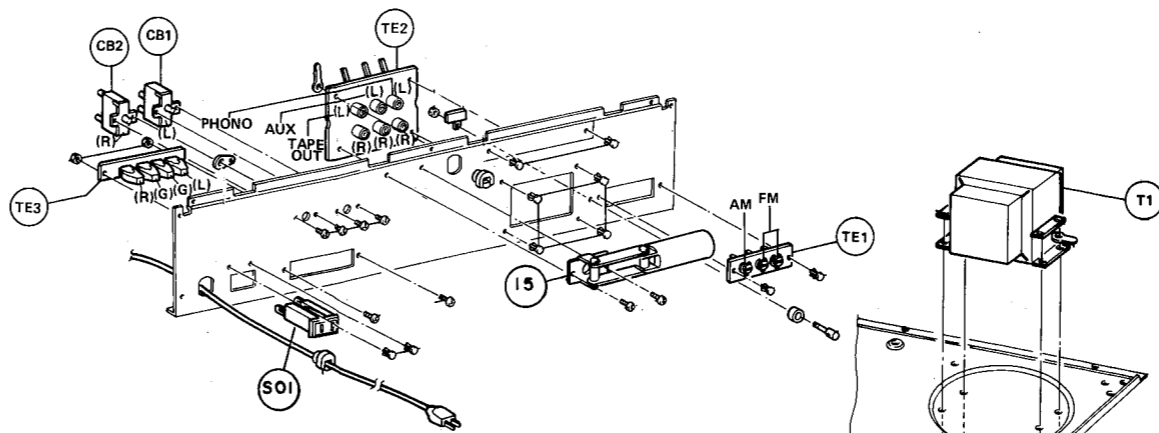
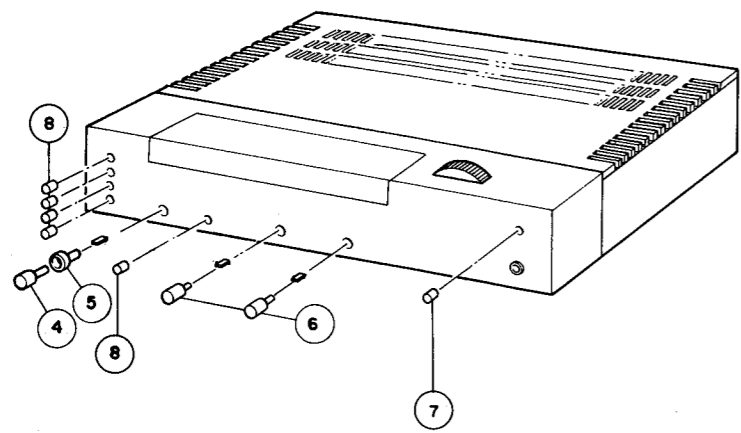

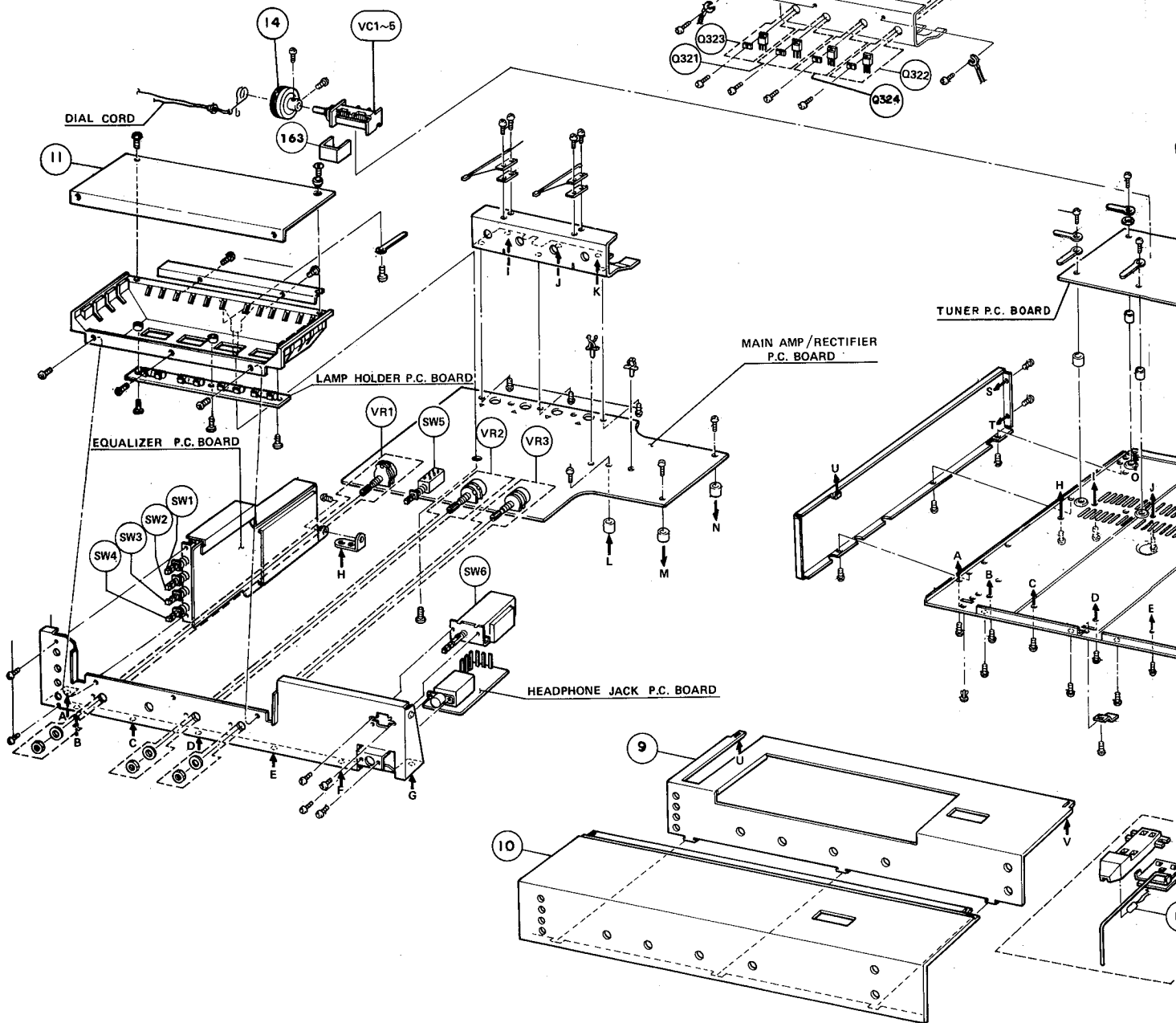
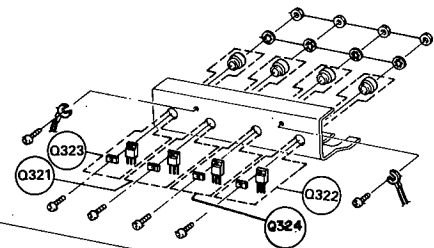
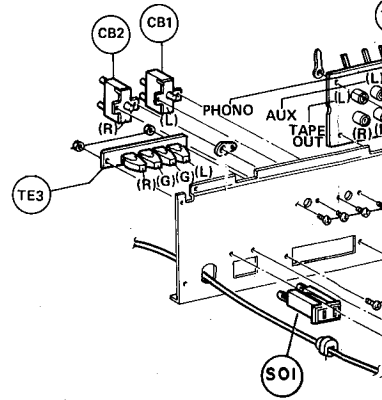
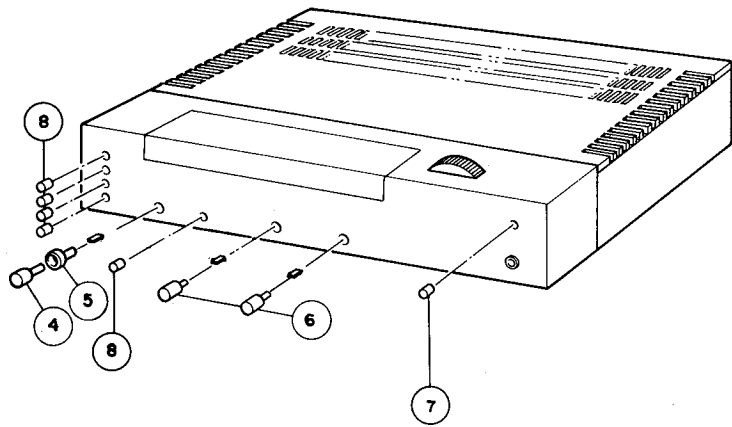

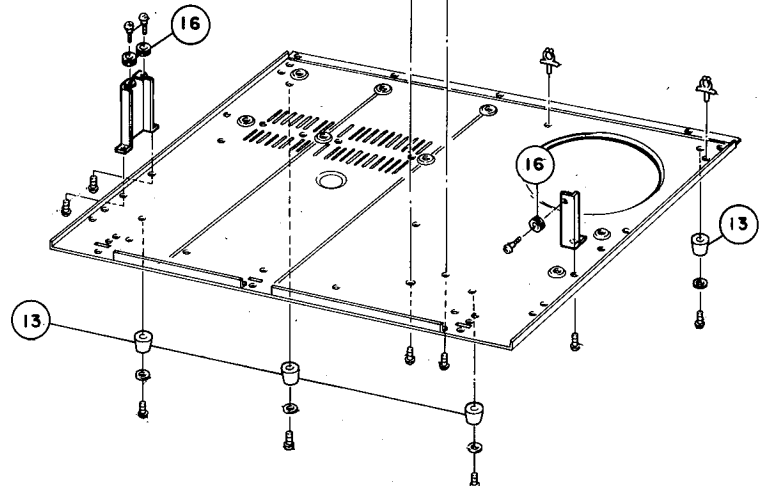
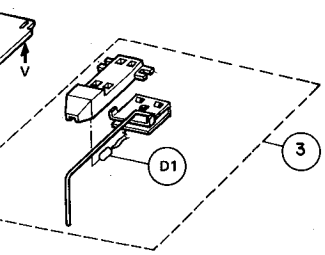
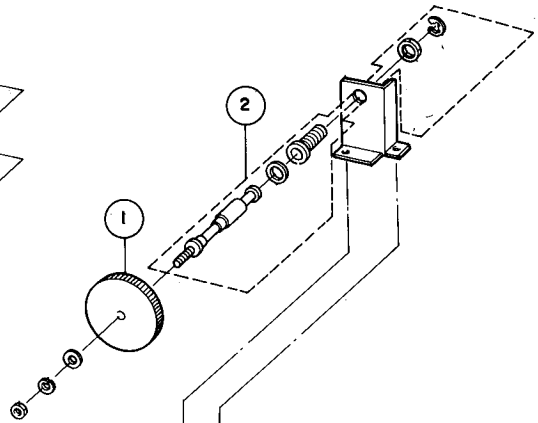
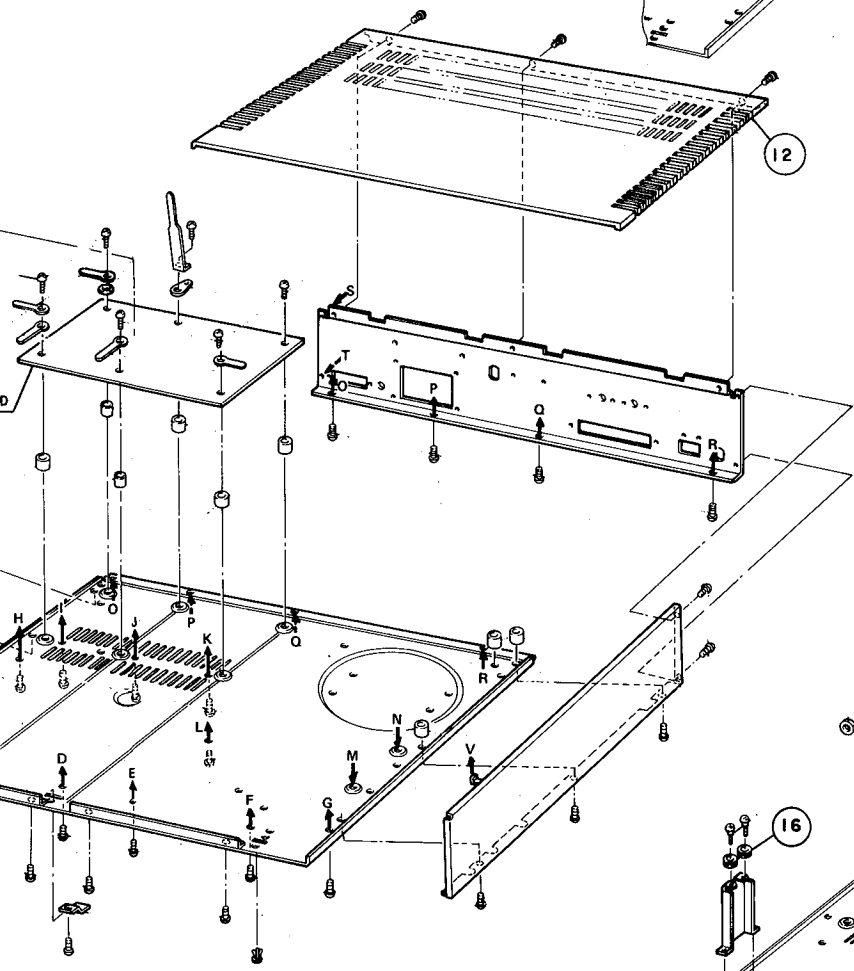
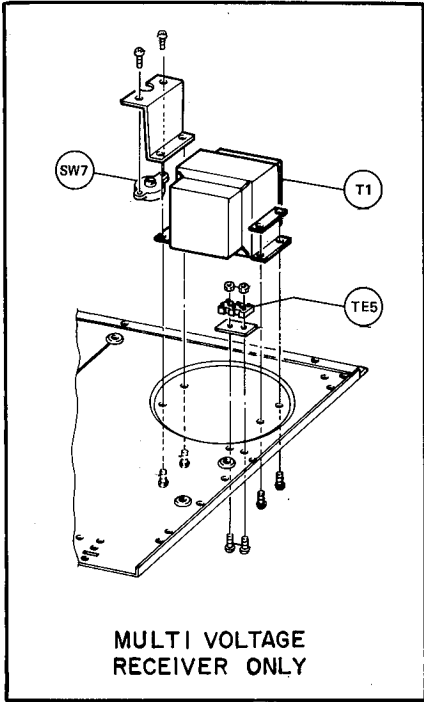
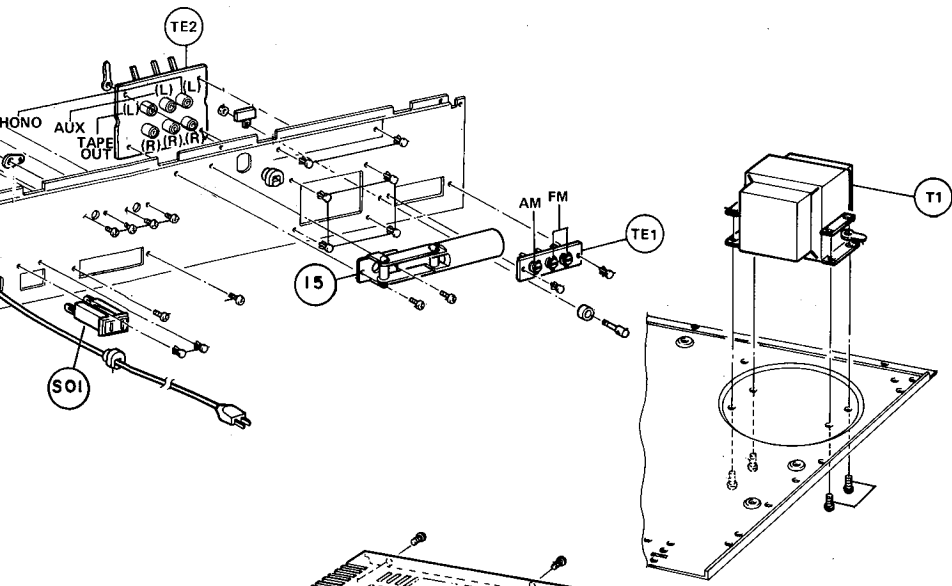

(EARLY VERSION) – MODEL 230e
 WIRING DIAGRAM – REGULAR VOLTAGE

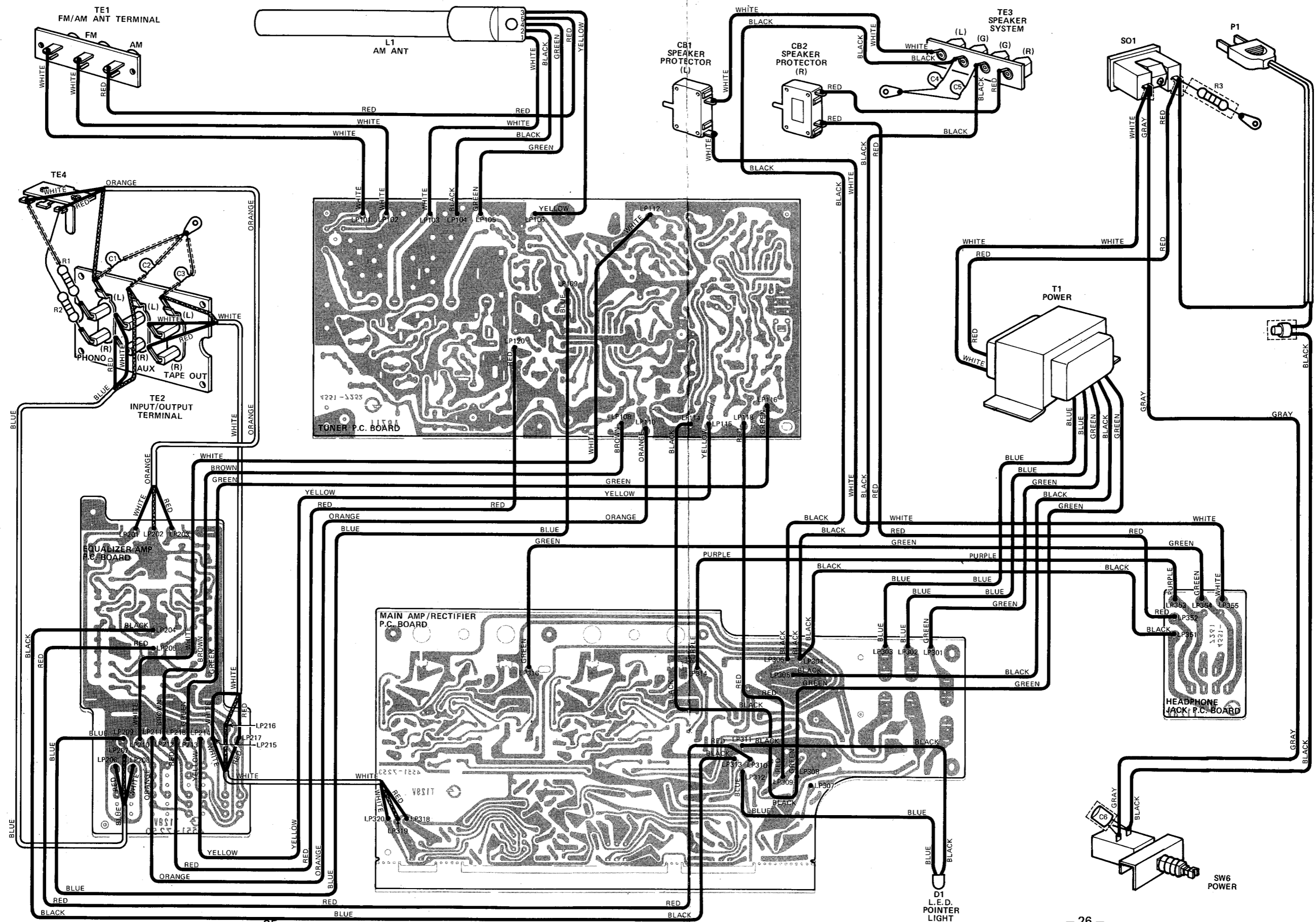

(EARLY VERSION) – MODEL 230e
 WIRING DIAGRAM – REGULAR VOLTAGE

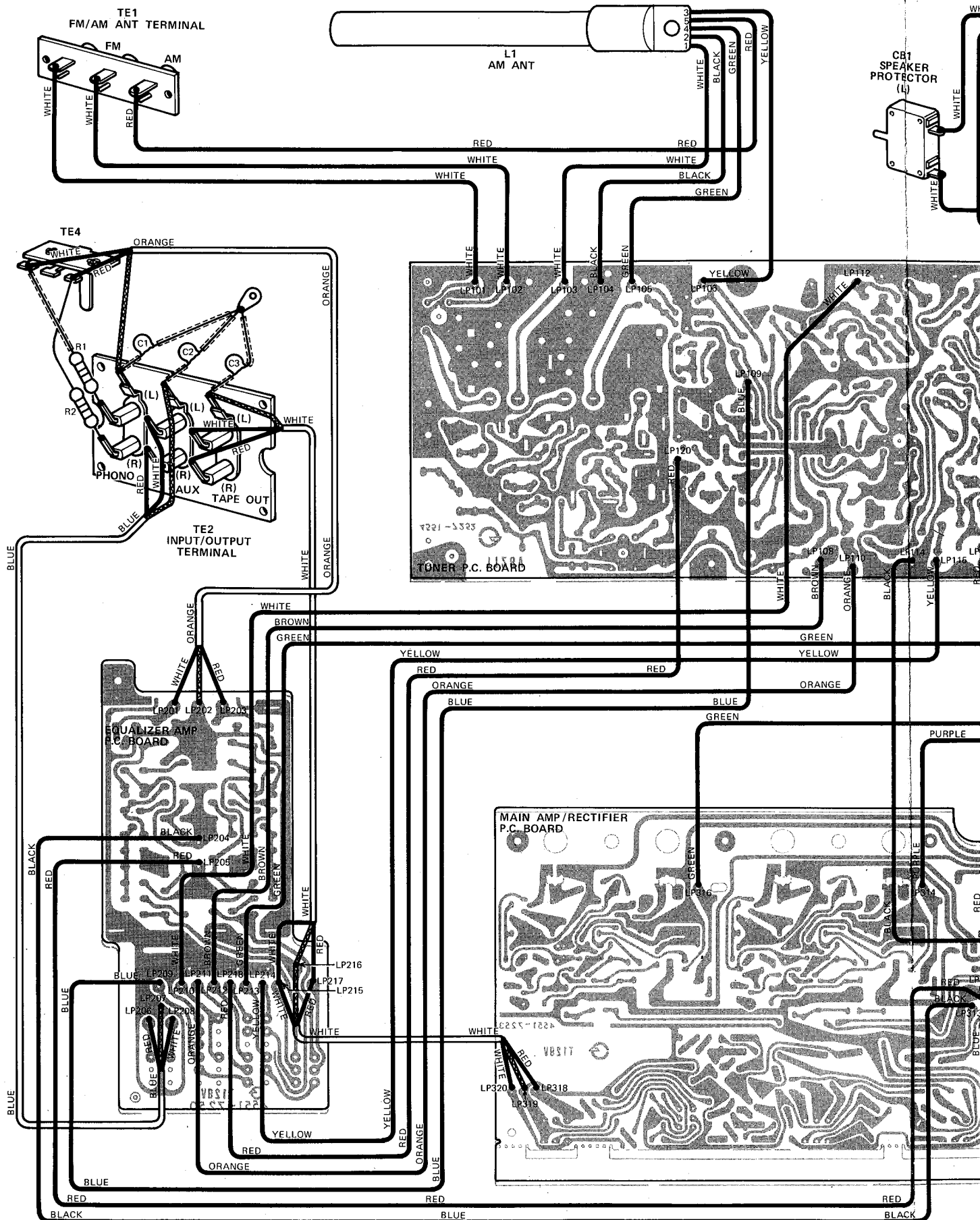

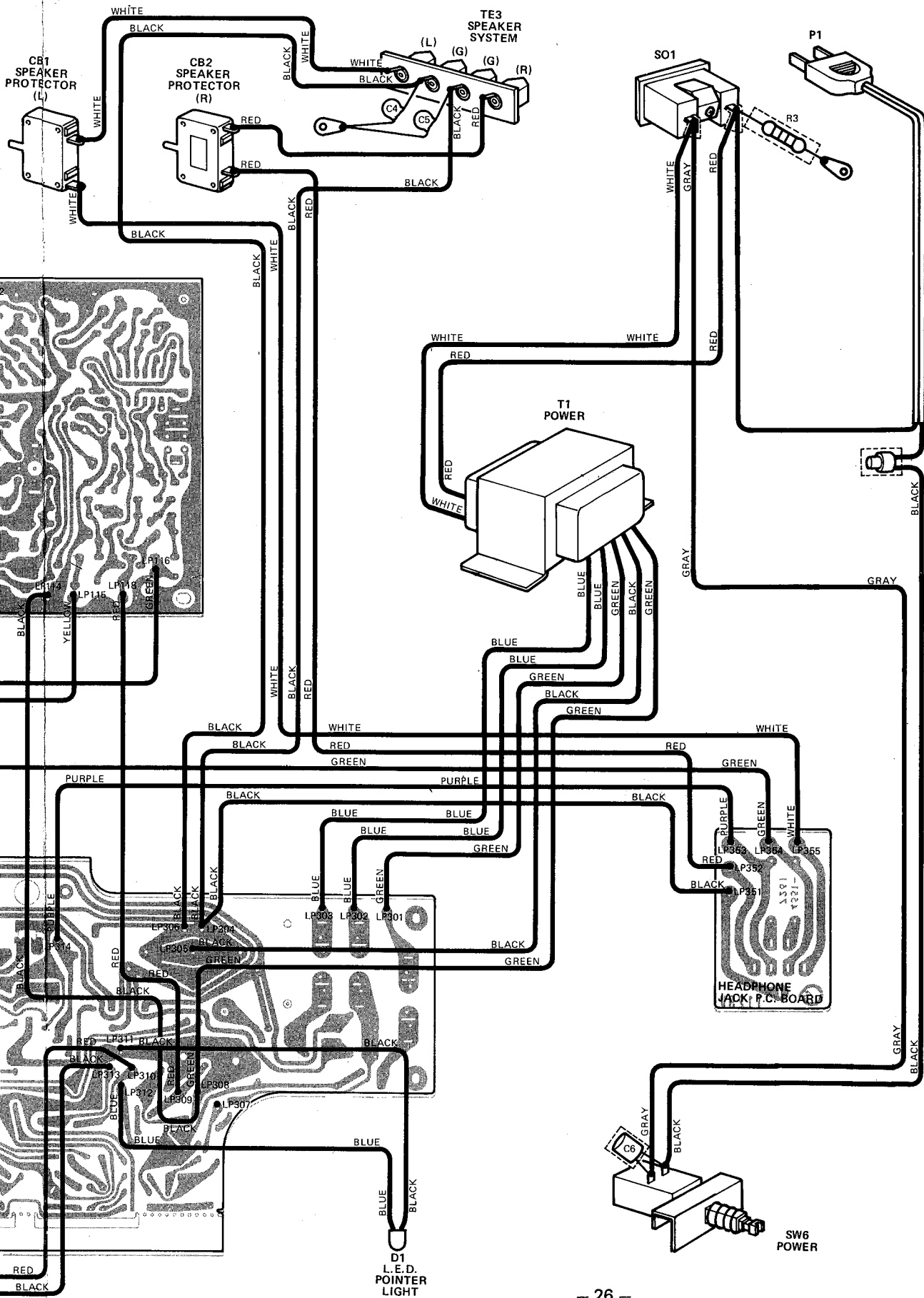

(EARLY VERSION) — MODEL 230e
 WIRING DIAGRAM — MULTI-VOLTAGE

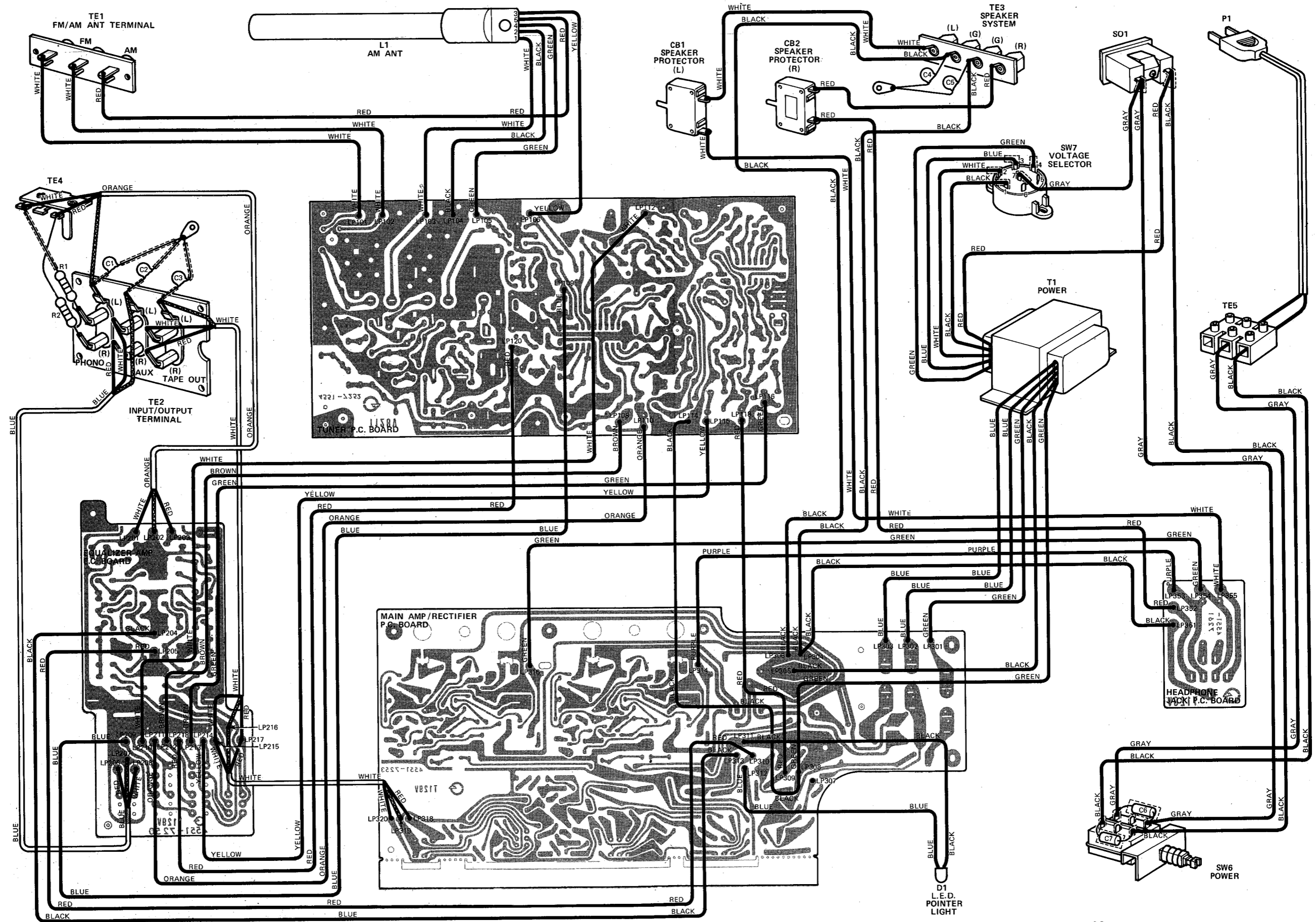

(EARLY VERSION) – MODEL 230e
WIRING DIAGRAM – MULTI-VOLTAGE

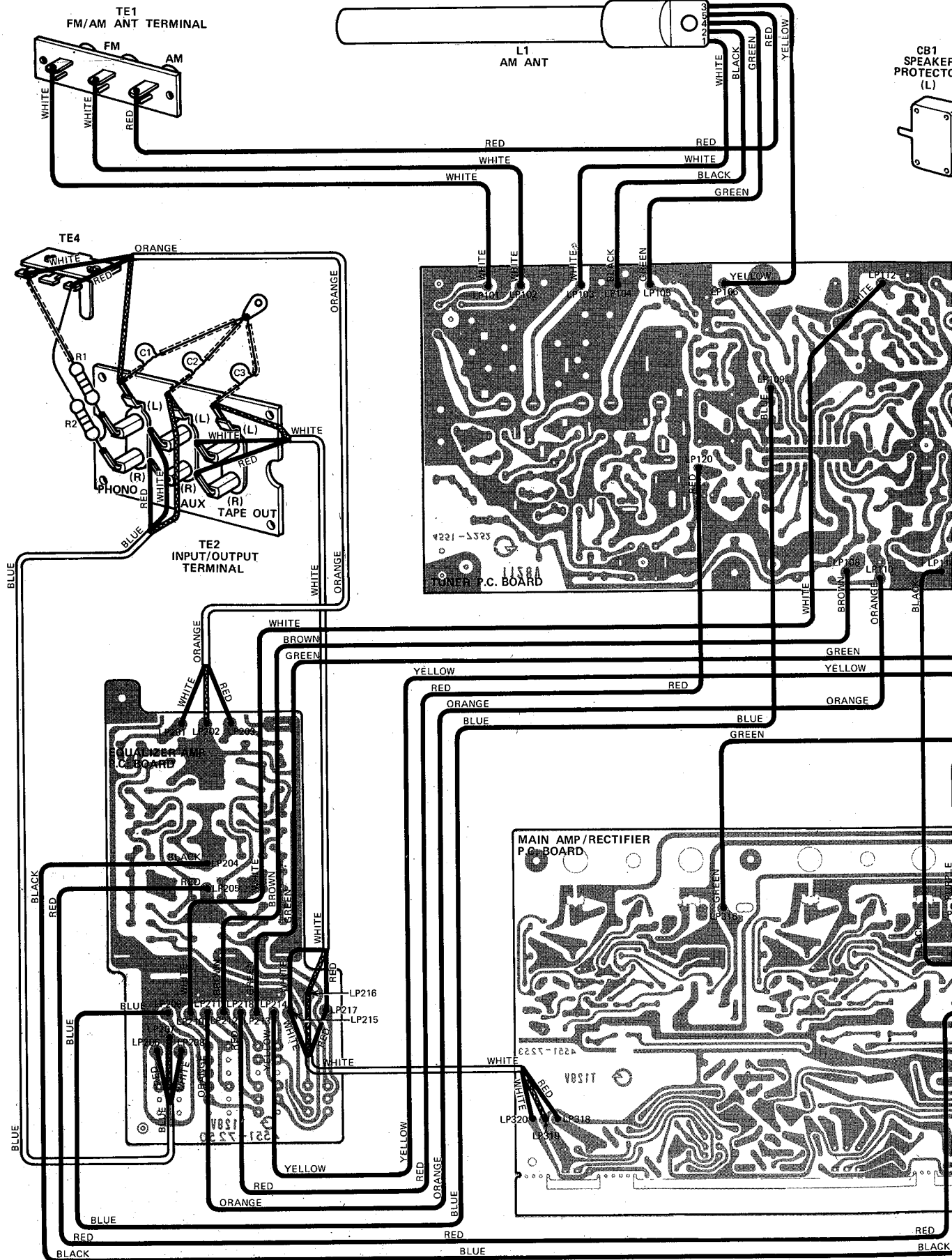

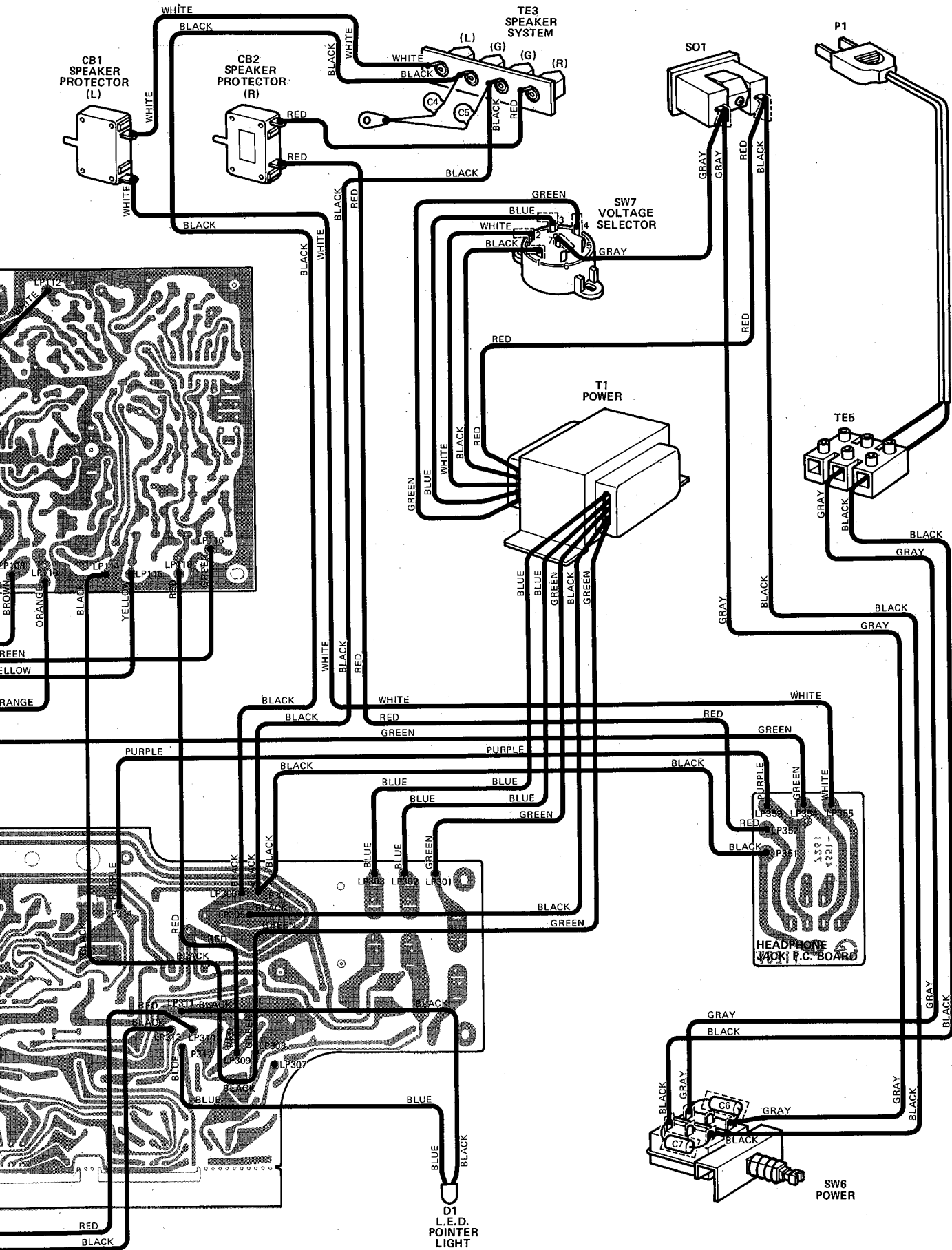

(EARLY VERSION) – MODEL 230e
 SCHEMATIC DIAGRAM – REGULAR VOLTAGE

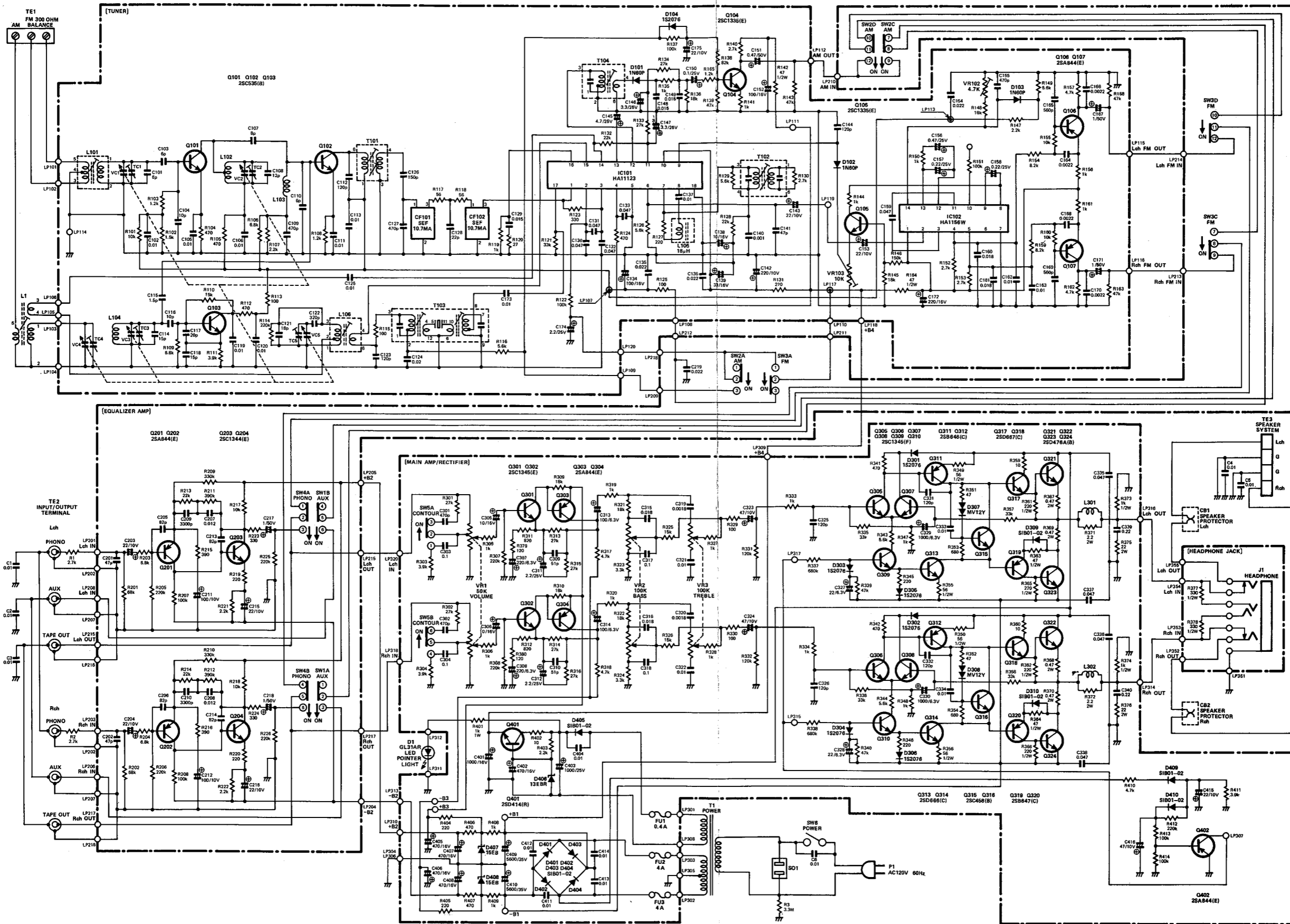

(EARLY VERSION) – MODEL 230e
 SCHEMATIC DIAGRAM – REGULAR VOLTAGE

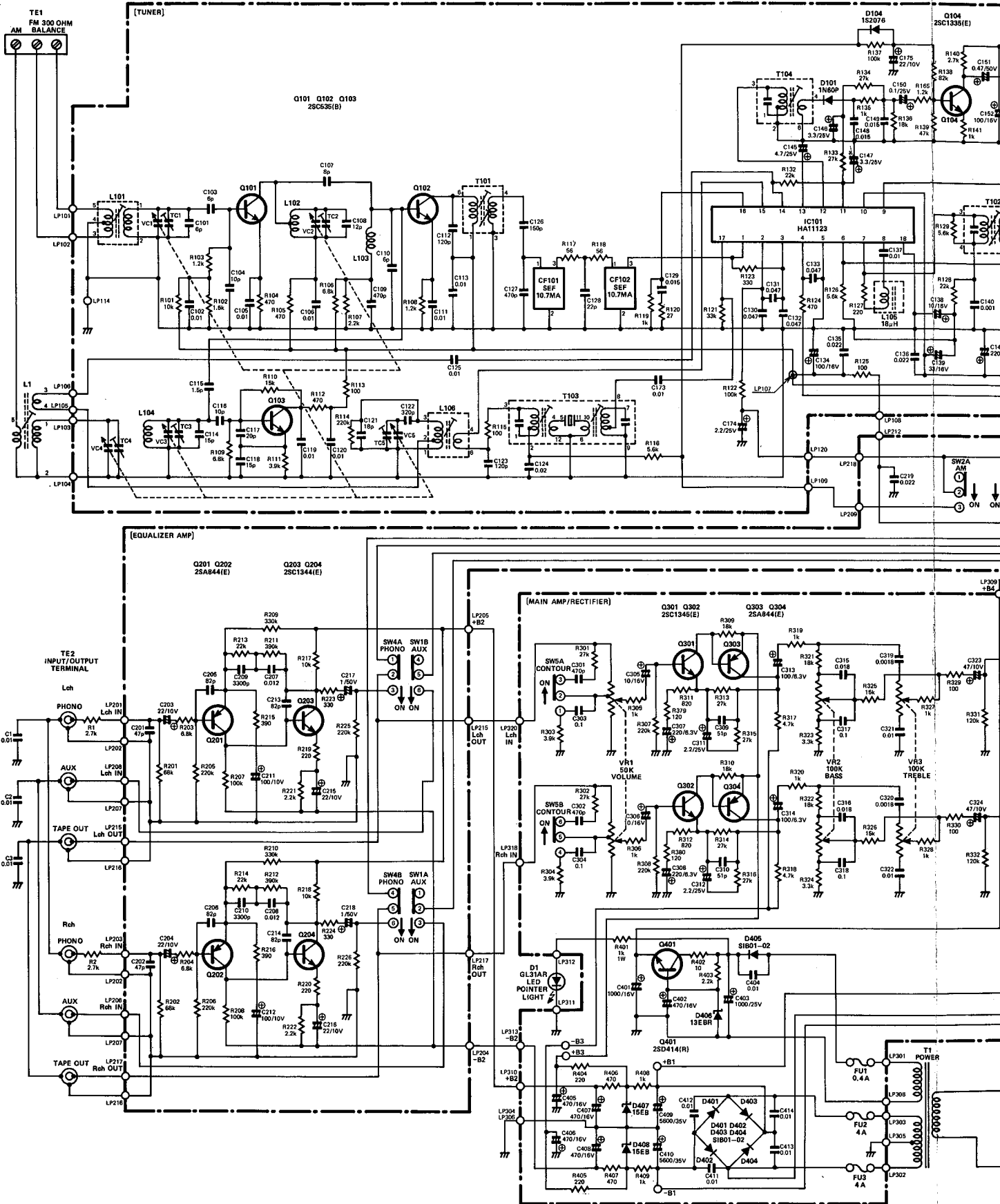

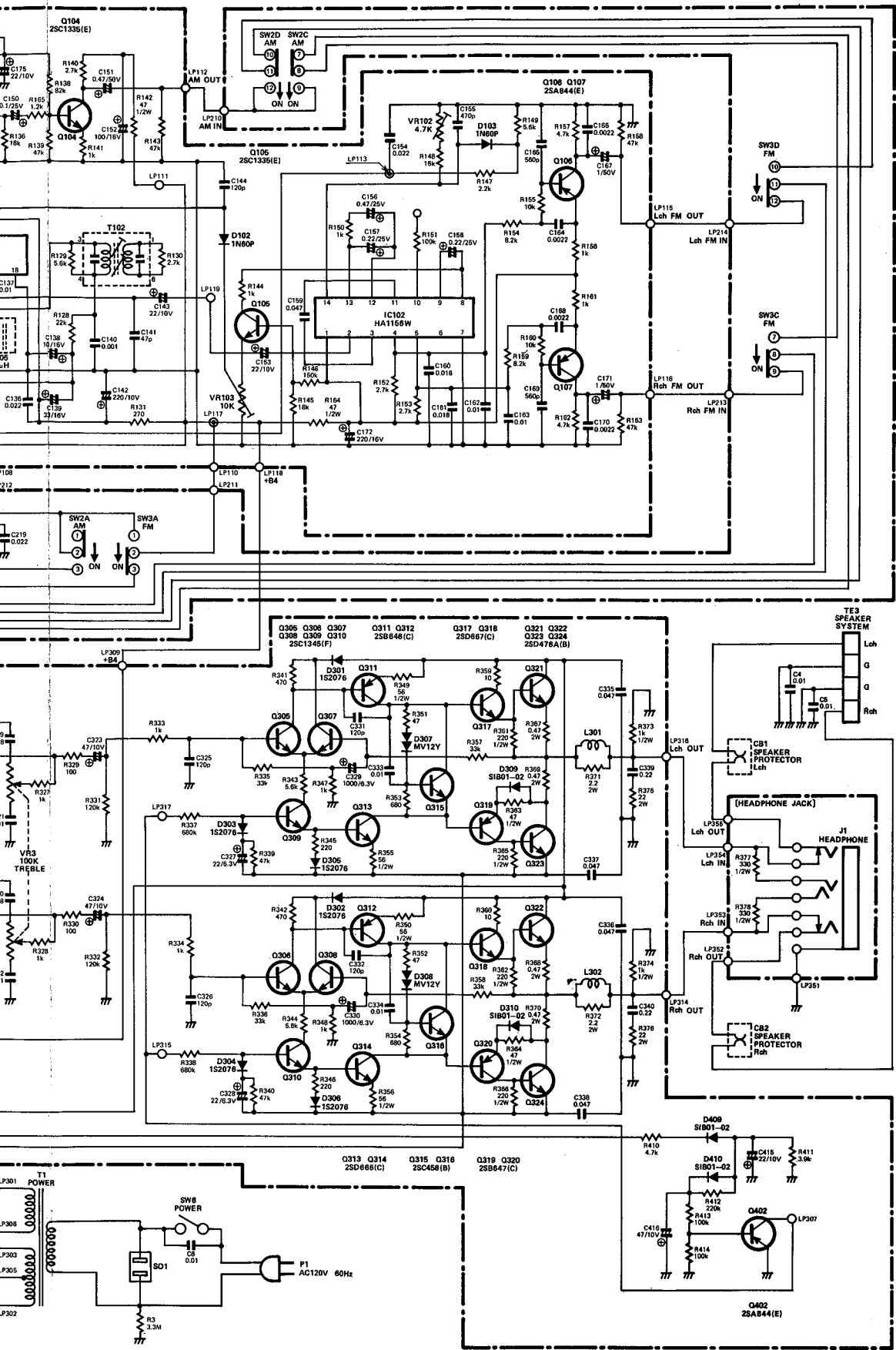

(EARLY VERSION) – MODEL 230e
SCHEMATIC DIAGRAM – MULTI-VOLTAGE

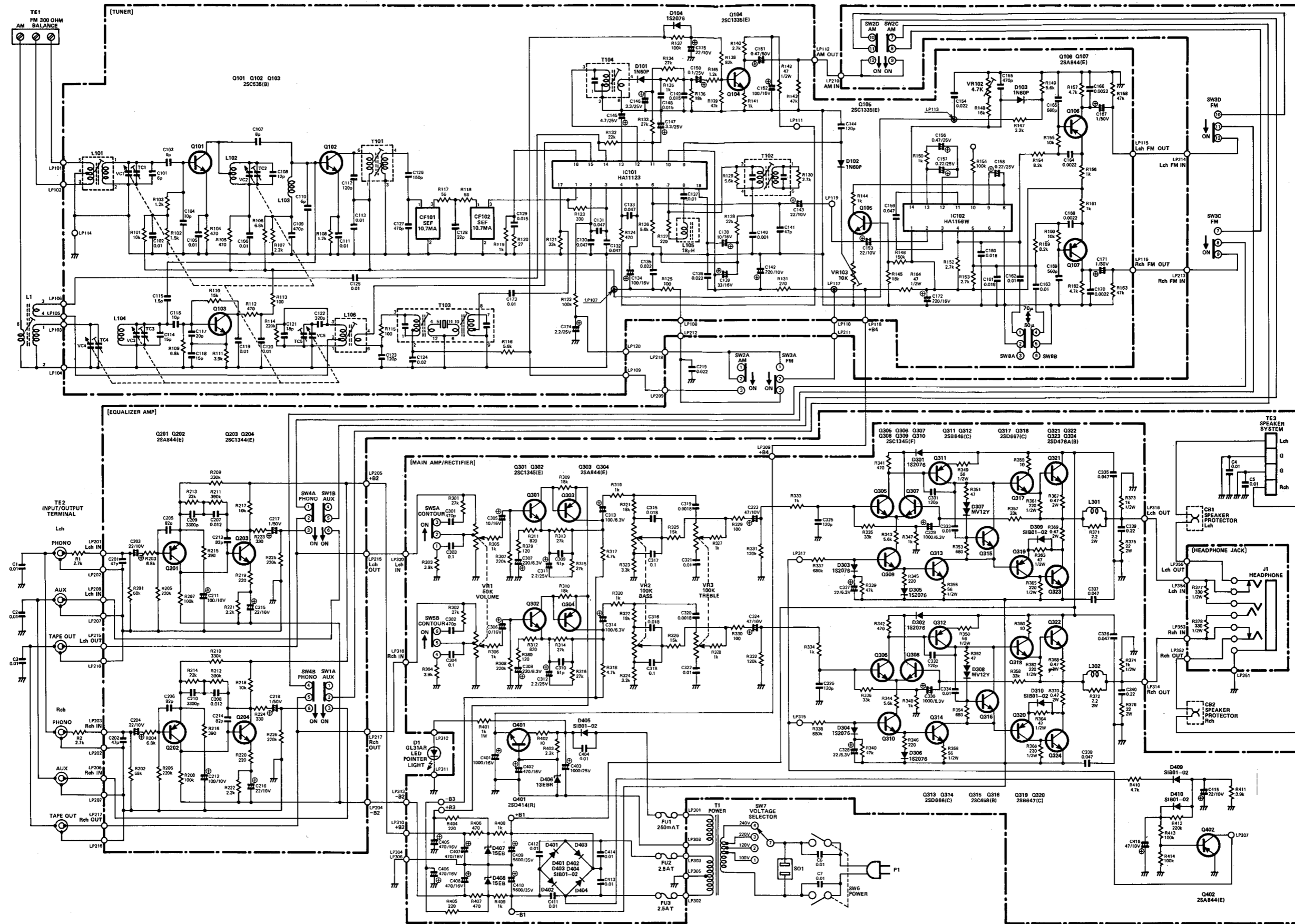

(EARLY VERSION) – MODEL 230e
 SCHEMATIC DIAGRAM – MULTI-VOLTAGE

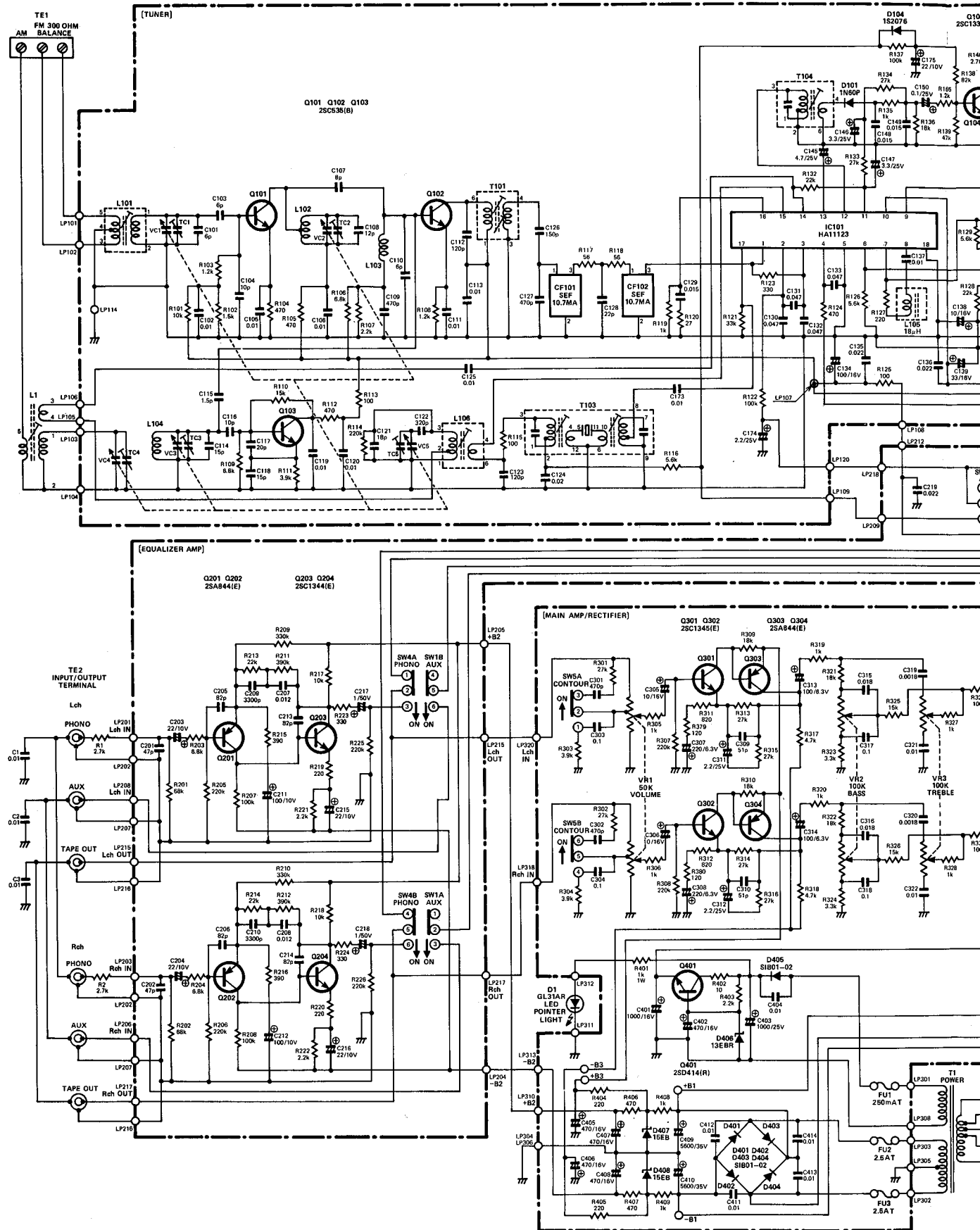

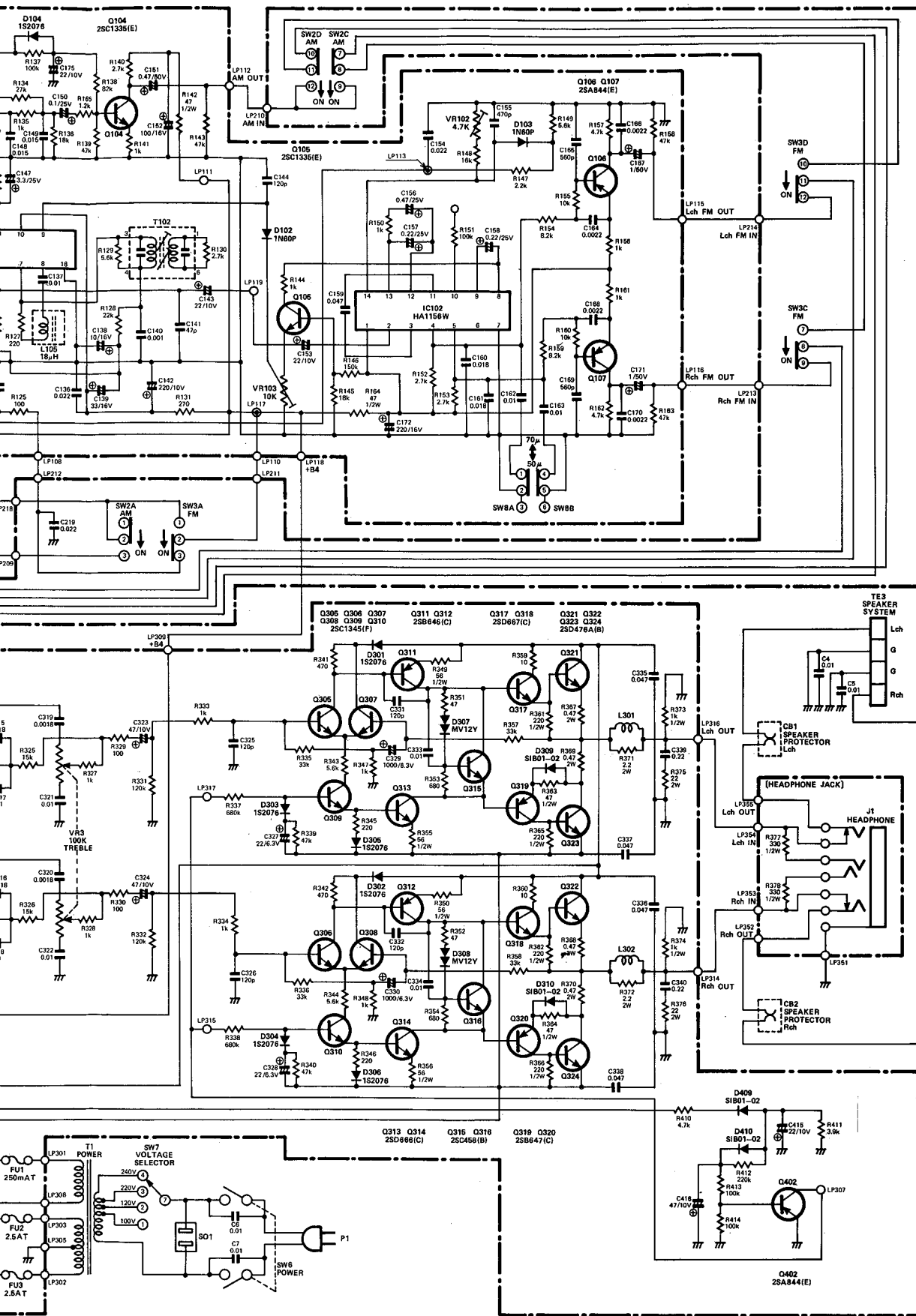

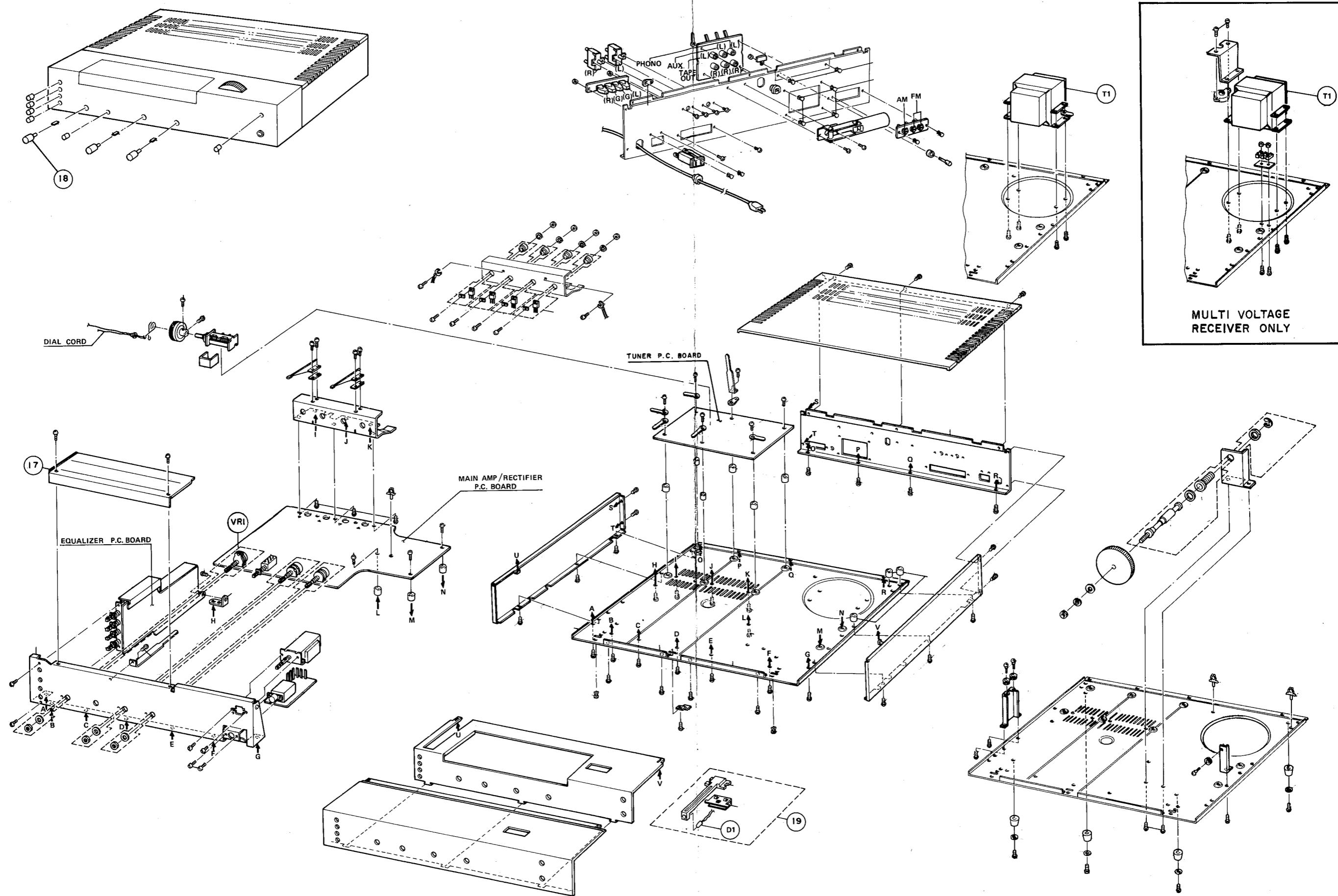

(EARLY VERSION) – MODEL 230e

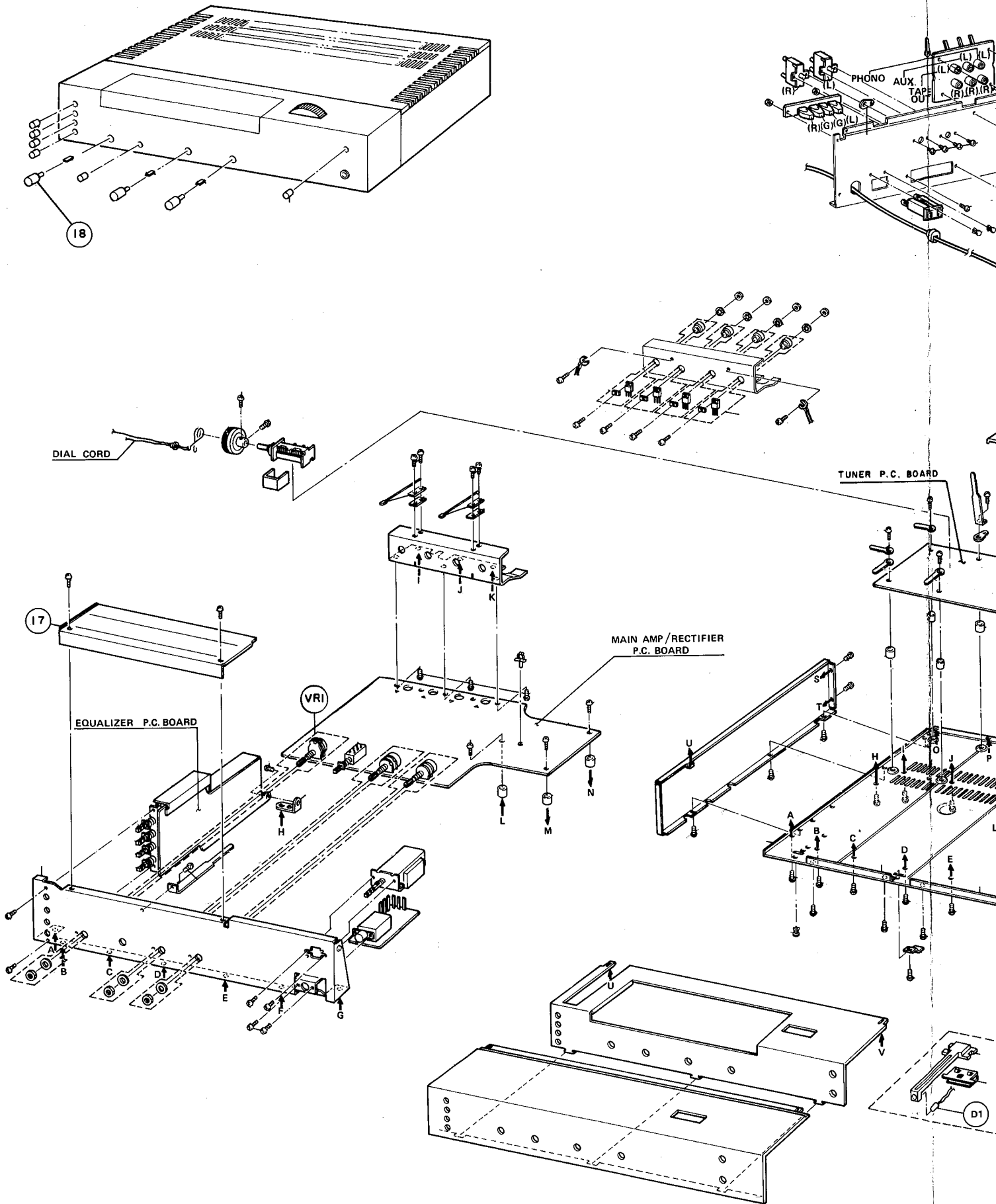

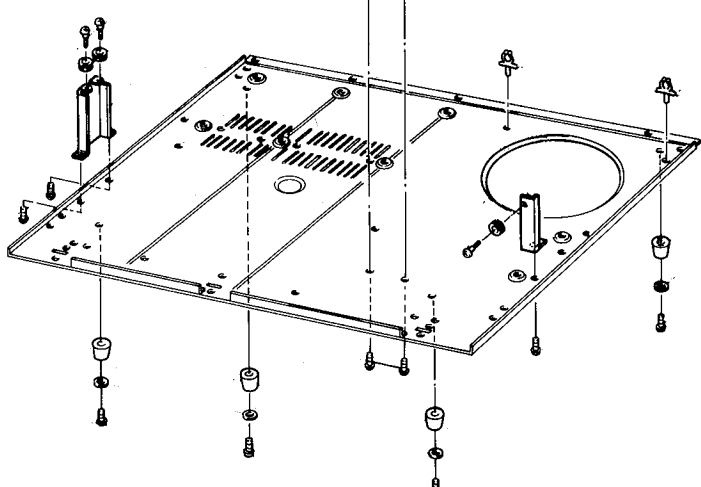
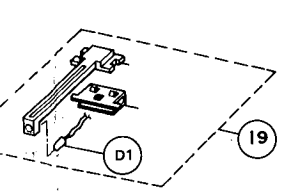
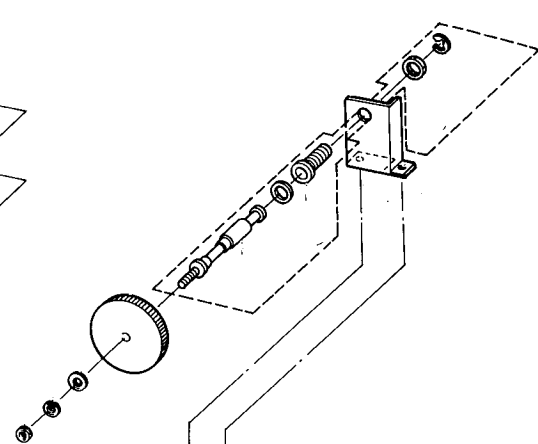
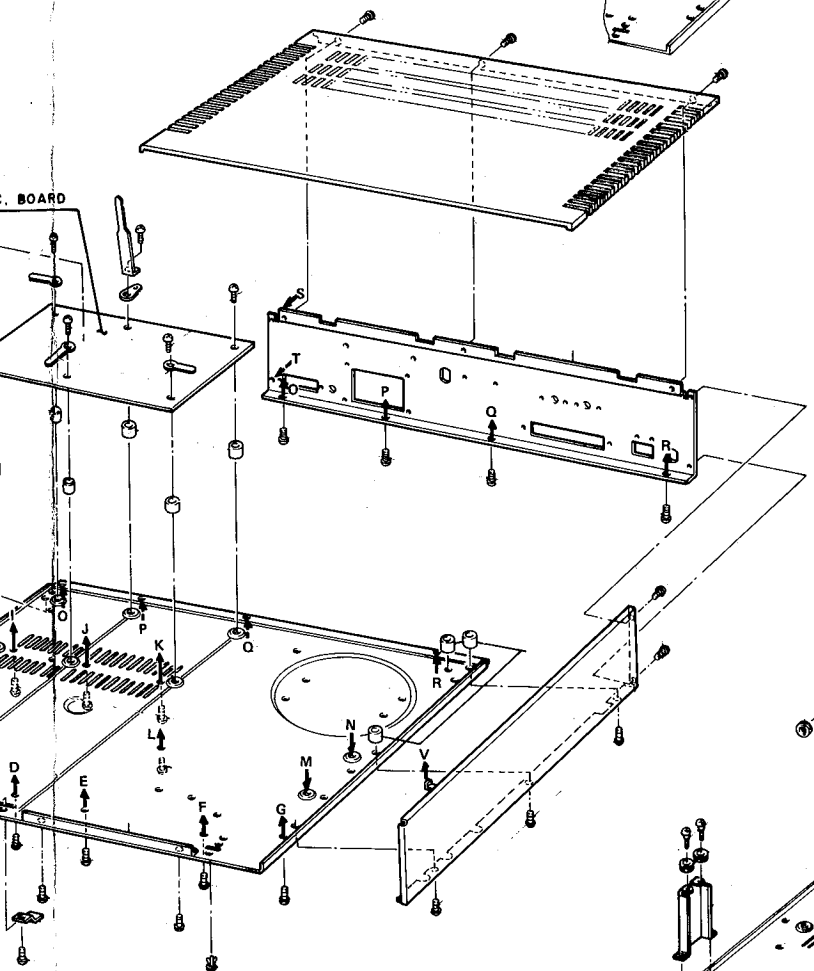
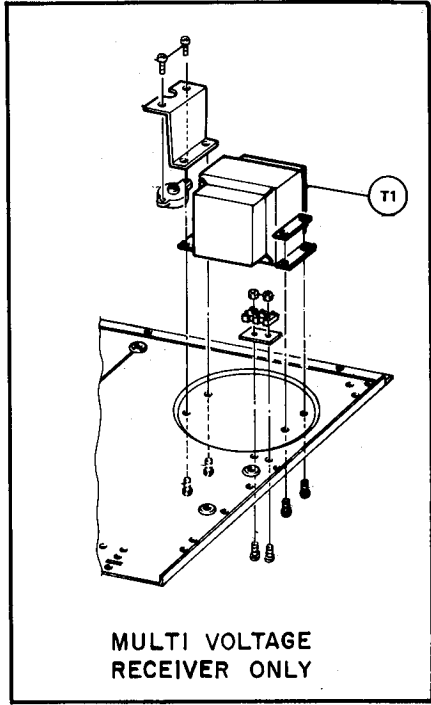
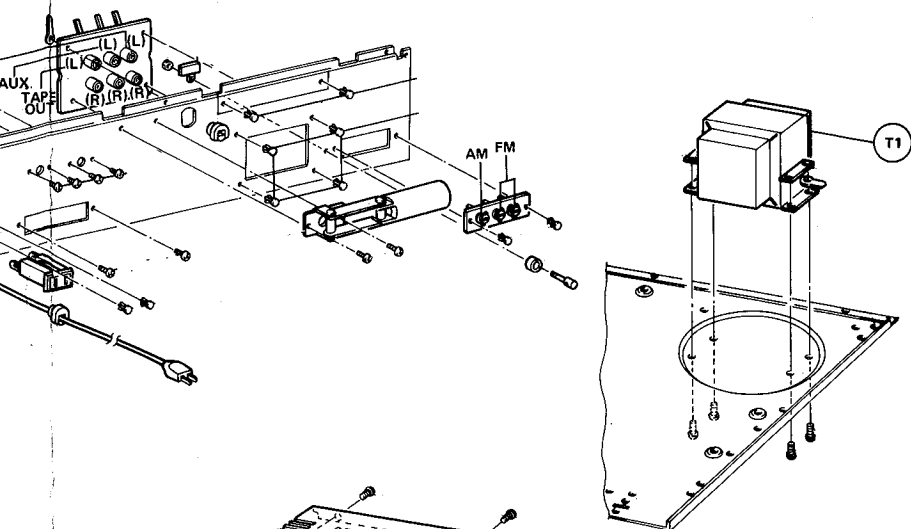

**DIFFERENCES DATA – MODEL 230e
(EARLY VERSION)**

REF DES.	H/K PART NO.	DESCRIPTION
CABINETRY		
17	61034861A	Dial Panel
18	63234862A	Knob Assy, Volume
19	00234948A	Dial Pointer Assy, (Incl Led DI)
MISCELLANEOUS		
	00134817A	PC BD Assy, Main Ampl/Rectifier
	00134818A	PC BD Assy, Tuner
	00134819A	PC BD Assy, Equalizer Ampl
T1	10134821A	Power Transformer
VR1	23534845A	Resistor, Variable, 100K Volume Control on Main Amp/Rectifier PC BD
MULTI-VOLTAGE RECEIVER		
T1	10134868A	Power Transformer
	00134866A	PC BD Assy, Main Ampl/Rectifier
	00134867A	PC BD Assy, Tuner

*RED
POINTER LED
46734827A*



NOTE TO WARRANTY STATIONS: Items marked by asterisk (*) are recommended spare parts stock. Printed circuit board assembly numbers are shown for reference only. HARMAN/KARDON DOES NOT NORMALLY SUPPLY ASSEMBLED PRINTED CIRCUIT BOARDS.

NOTE: To speed handling of your order be sure to include both the model and serial numbers, in addition to the quantity, Harman/Kardon part number and part description of the items ordered. Orders from independent dealers, independent servicemen, and retail customers will be shipped on a cash in advance basis. Harman/Kardon reserves the right to substitute equivalent parts for those originally installed in this chassis. All parts should be ordered from Harman/Kardon, 55 Ames Court, Plainview, L.I., N.Y. 11803. Att: Parts Department.