

# The Harman Kardon Model HK6600

## INTEGRATED AMPLIFIER

Manual 148A

# Technical Manual

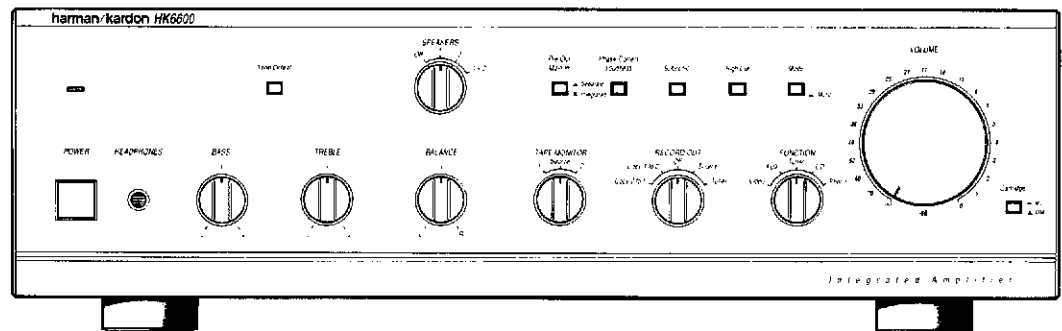

The following marks found in the parts list of this manual identify the models as follows.

- BK : North America area model Black version
- G : German model
- GB : German model Black version
- I : International model
- IB : International model Black version

**harman/kardon**

240 Crossways Park West, Woodbury, N. Y. 11797  
1112-3152148A1 P-088906 1500 Printed in Japan

**SPECIFICATIONS**

	Nominal	Limit
<b>RMS Output Power</b>		
8Ω, 1kHz THD 0.08%	106W	≧ 90W
4Ω, 1kHz THD 0.1%	102W	≧ 90W
<b>High Instantaneous Current Capability (HCC)</b>	51A	≧ 43A
<b>Half Power Bandwidth</b>	10Hz ~ 100kHz	
<b>Frequency Response at -3dB</b>	0.25Hz ~ 330kHz*	
<b>Input Sensitivity</b>		
Video/CD, Tuner	135mV ± 25mV	
Phono (MM)	2.2mV ± 0.3mV*	
Phono (MC)	130μV ± 20μV*	
<b>Signal to Noise Ratio</b>		
Video/CD, Tuner	79dB	≧ 75dB
Phono (MM)	78dB	≧ 73dB
Phono (MC)	76dB	≧ 72dB
<b>Channel Separation at 10kHz</b>		
Video/CD	55dB	≧ 43dB
Phono (MM), Tuner	59dB	≧ 43dB
Phono (MC)	58dB	≧ 43dB
<b>IM Distortion Ratio</b>	0.085%	≧ 0.15%
<b>Damping Factor at 1kHz</b>	70	≧ 50
<b>Tone Control Characteristics</b>		
<b>Bass at 50Hz</b>		
Boost	10dB	± 2dB
Cut	10dB	± 2dB
<b>Treble at 10kHz</b>		
Boost	10dB	± 2dB
Cut	10dB	± 2dB

	Nominal	Limit
<b>Filters</b>		
Subsonic	15Hz,	-3dB ± 1dB/Octave
High Cut	6kHz,	-3dB ± 1dB/Octave
<b>DC Output Voltage</b>		
L channel		0mV ± 60mV
R channel		0mV ± 60mV
<b>RIAA Equalization at Tape Out</b> (20Hz/20kHz) (No load)		+0.2dB ± 0.5dB/0dB ± 0.5dB
<b>Phono Over Load (No load)</b>		
Phono (MM)		200mV ≧ 160mV
Phono (MC)		12mV ≧ 8mV
<b>Dimensions (W x H x D)</b>	17-1/2" x 5-5/16" x 15-11/16"	(443 x 134 x 398mm)
<b>Weight</b>		22lbs. 11oz. (10.3kg)
<b>Power Supplies</b>		
North America area model	AC 120V, 60Hz	
International model	AC 220/240V, 50/60Hz	
<b>Power Consumption</b>		
North America area model	340W (340VA)	
International model	230W	

\* Input Sensitivity for International model are 2.3mV ± 0.3mV (MM) and 140μV ± 20μV (MC).

\* Frequency Response International model 0.25Hz ~ 260kHz

These specifications are service target specs.

Specifications and components subject to change without notice. Overall performance will be maintained or improved.

**LEAKAGE TEST (FOR SERVICE ENGINEERS IN THE U.S.A.)**

Before returning the unit to the user, perform the following safety checks:

1. Inspect all lead dress to make certain that leads are not pinched or that hardware is not lodged between the chassis and other metal parts in the unit.
2. Be sure that any protective devices such as nonmetallic control knobs, insulating fishpapers, cabinet backs, adjustment and compartment covers or shields, isolation resistor-capacity networks, mechanical insulators, etc. which were removed for servicing are properly reinstalled.
3. Be sure that no shock hazard exists; check for leakage current using Simpson Model 229 Leakage Tester, standard equipment item No. 21641, RCA Model WT540A or use alternate method as follows: Plug the power cord directly into a 120-volt AC receptacle (do not use an Isolation Transformer for this test). Using two clip leads, connect a 1500 Ohm, 10-watt resistor paralleled by a 0.15 μF capacitor, in series with all exposed metal cabinet parts and a known earth ground, such as a water pipe or conduit. Use a VTVM or VOM with 1000 Ohms per volt, or higher sensitivity to measure the AC voltage drop across the resistor. (See Diagram.) Move the resistor connection to each exposed metal part having a return path to the chassis (antenna, metal, cabinet, screw heads, knobs and control shafts, escutcheon, etc.) and measure the AC voltage drop across the resistor. (This test should be performed with the power switch in both the On and Off positions.) A reading of 0.35 volt RMS or more is excessive and indicates a potential shock hazard which must be corrected before returning the unit to the owner.

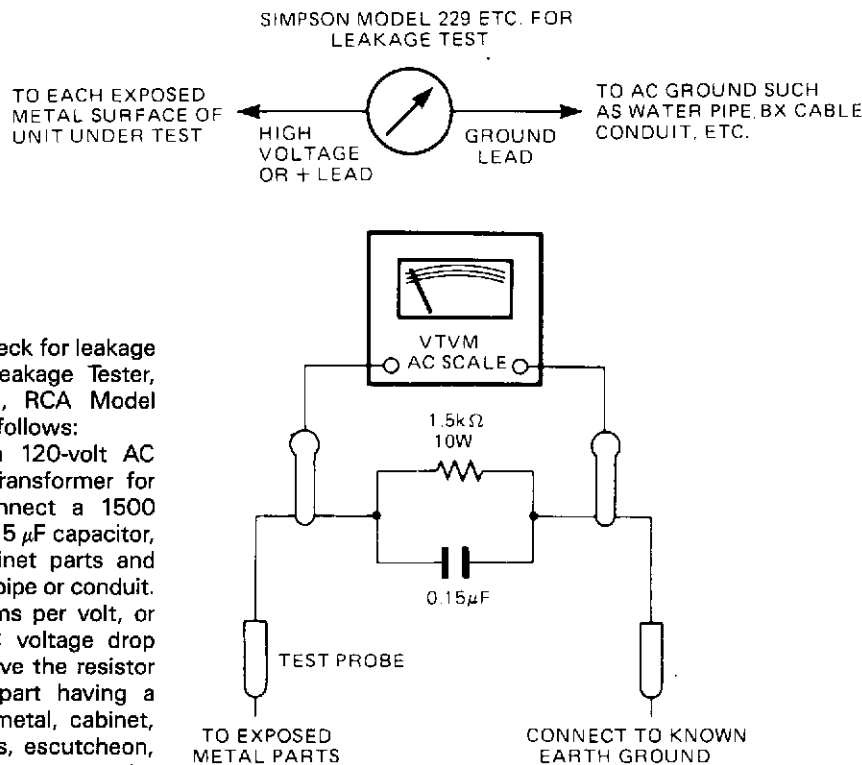

**DISASSEMBLY PROCEDURES (REFER TO PAGES 5 AND 20)**

**① CABINET TOP (131) REMOVAL**

Remove 8 screws (A) and then remove the Cabinet Top (131).

**② FRONT PANEL ASS'Y (AA) REMOVAL**

1. Remove the Cabinet Top (131), referring to the previous step ①.  
 2. Remove 5 screws (B) and then remove the Front Panel Ass'y (AA).

**③ MAIN P. C. BOARD (PCB-1) REMOVAL**

1. Remove 9 screws (C) and then remove the Cabinet Bottom Ass'y (AC).  
 2. Remove the Front Panel Ass'y (AA), referring to the previous step ②.  
 3. Loosen 2 hexagon-socket-head screws (D) and pull out the Shaft Ass'y (BC) with the Rotary Knob Ass'y (AD).  
 4. Remove 7 screws (E) and then remove the Main P. C. Board (PCB-1) with the Heat Sink (177). At this time, unsolder the lead wires connected to the Main P. C. Board (PCB-1).

**④ FUSE P. C. BOARD (PCB-3) REMOVAL**

1. Remove the Front Panel Ass'y (AA), referring to the previous step ②.  
 2. Pull out the Levers (213).  
 3. Remove 3 screws (F), then remove the Fuse P. C. Board (PCB-3). If necessary unsolder the lead wires.

**⑤ TONE 1 P. C. BOARD (PCB-5) REMOVAL**

1. Remove the Front Panel Ass'y (AA), referring to the previous step ②.  
 2. Pull out the Shaft Ass'y (BC) with the Rotary Knob Ass'y (AD), referring to the Previous step ③.  
 3. Pull out the 4 Rotary Knob Ass'y (AD), 3 Rotary Knobs (153), Power Push Button (146) and Levers (213).  
 4. Remove screw (G), plastic rivet (H) and 4 screws (I) mounting the Metal Fitting (165), then remove the Metal Fitting (165) with the Equalizer P. C. Board (PCB-10).  
 5. Straighten the catches fixing the LED P. C. Board (PCB-12) and then remove it.  
 6. Remove the metal fixture (J) fixing the Headphone P. C. Board (PCB-2) and then remove it.  
 7. Remove 7 hexagon nuts (K) and remove 4 screws (L).  
 8. Remove 7 screws (M) and the Chassis Ass'y (BA), then the Tone 1 P. C. Board (PCB-5), Tone 2 P. C. Board (PCB-6) and Volume P. C. Board (PCB-7) can be removed. Unsolder the lead wires if necessary when removing each P. C. Board.

**POWER CORD REPLACEMENT (FOR SERVICE ENGINEERS OTHER THAN NOTRH AMERICA)**

In order to prevent fire or shock hazard when replacing the power cord, follow the procedure below to replace the parts with the standard supply parts.

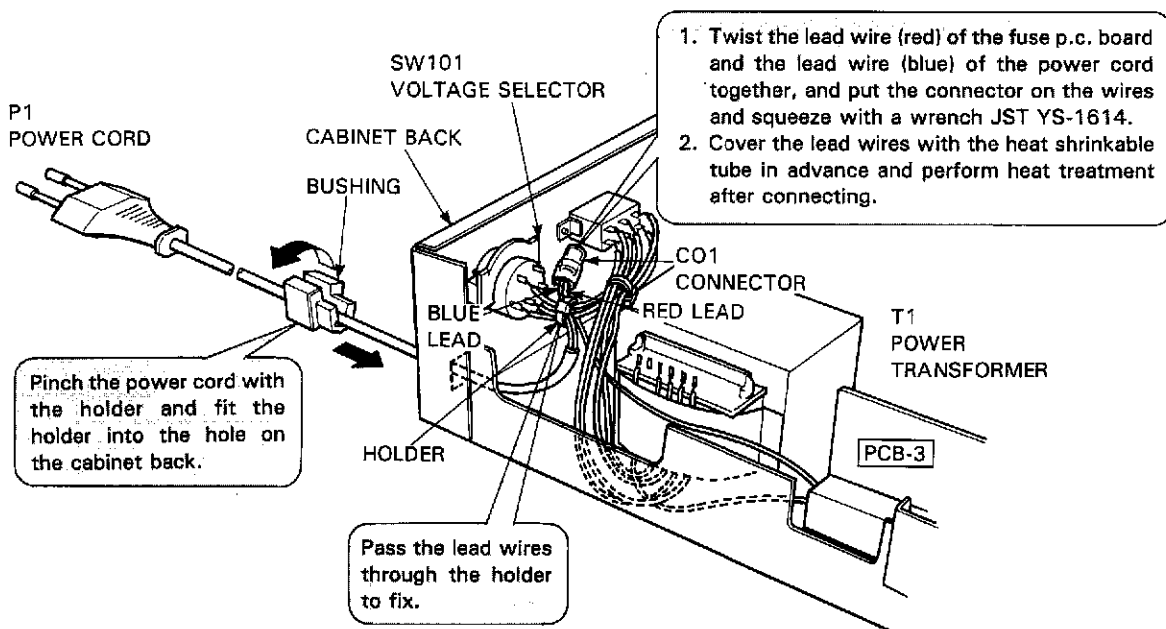

1. Twist the lead wire (red) of the fuse p.c. board and the lead wire (blue) of the power cord together, and put the connector on the wires and squeeze with a wrench JST YS-1614.  
 2. Cover the lead wires with the heat shrinkable tube in advance and perform heat treatment after connecting.

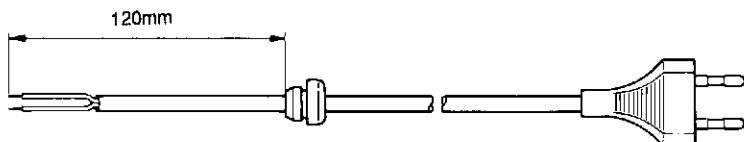

## ALIGNMENT PROCEDURES (REFER TO PAGES 7, 8, 9 AND 19)

- Conditions:
  - Set the Function selector to the "CD" position.
  - Set the Volume control to minimum.
  - Set the Speaker selector to the "off" position.
  - Make the adjustment at a room temperature of 77°F (25°C).

### ■ DC BALANCE ADJUSTMENT

- Set the Speaker Operating Mode switch to the "8Ω" position.

Step	Connection Equipments	Adjustment	For
1	Connect the Digital Volt Meter to TP1 and TP2.	VR401	0 ± 10mV
2	Connect the Digital Volt Meter to TP3 and TP2.	VR402	0 ± 10mV

### ■ IDLING CURRENT ADJUSTMENT

Step	Connection Equipments	Adjustment	For
1	Connect the Digital Volt Meter to TP4 and TP5.	VR403	40mV
2	Connect the Digital Volt Meter to TP6 and TP7.	VR404	40mV

### ■ DC BALANCE CONFIRMATION

- Set the Speaker Operating Mode switch to the "4Ω" position.

Step	Connection Equipments	For
1	Connect the Digital Volt Meter to TP1 and TP2.	0 ± 60mV
2	Connect the Digital Volt Meter to TP3 and TP2.	0 ± 60mV

■ After the above adjustment, leave the unit with its power on for longer than 15 minutes and then repeat the same adjustment.

## BLOCK DIAGRAM

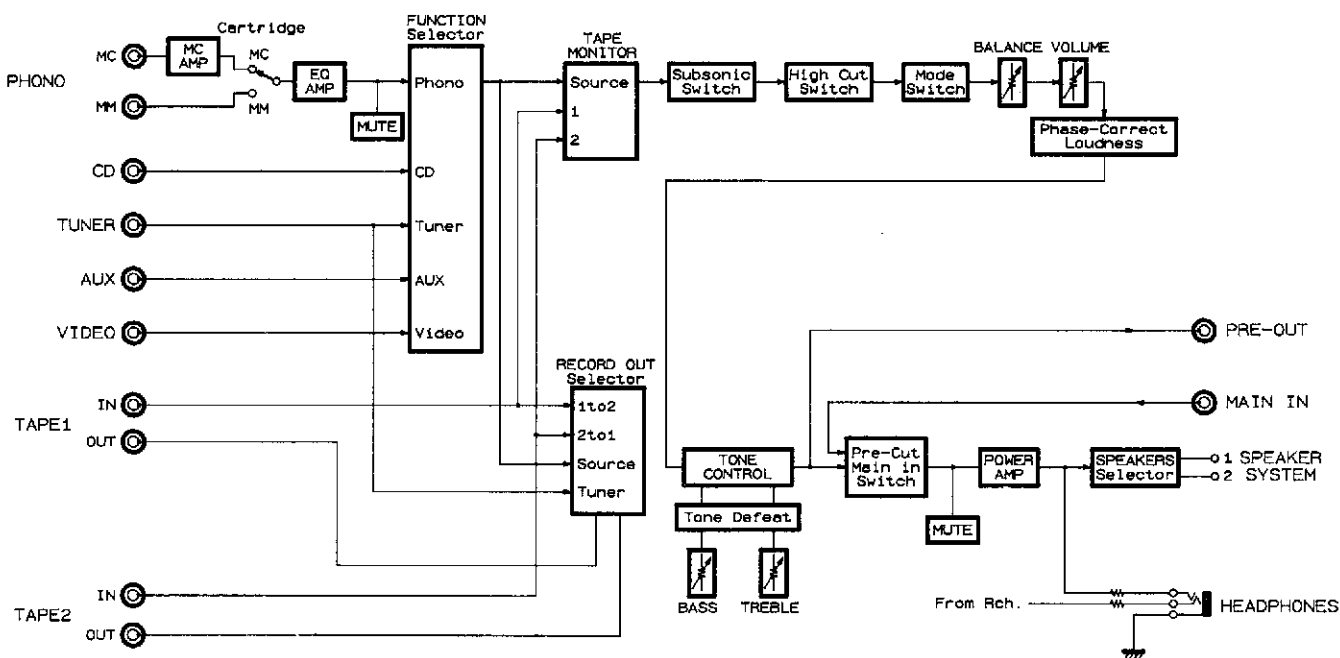

# GENERAL UNIT EXPLODED VIEW

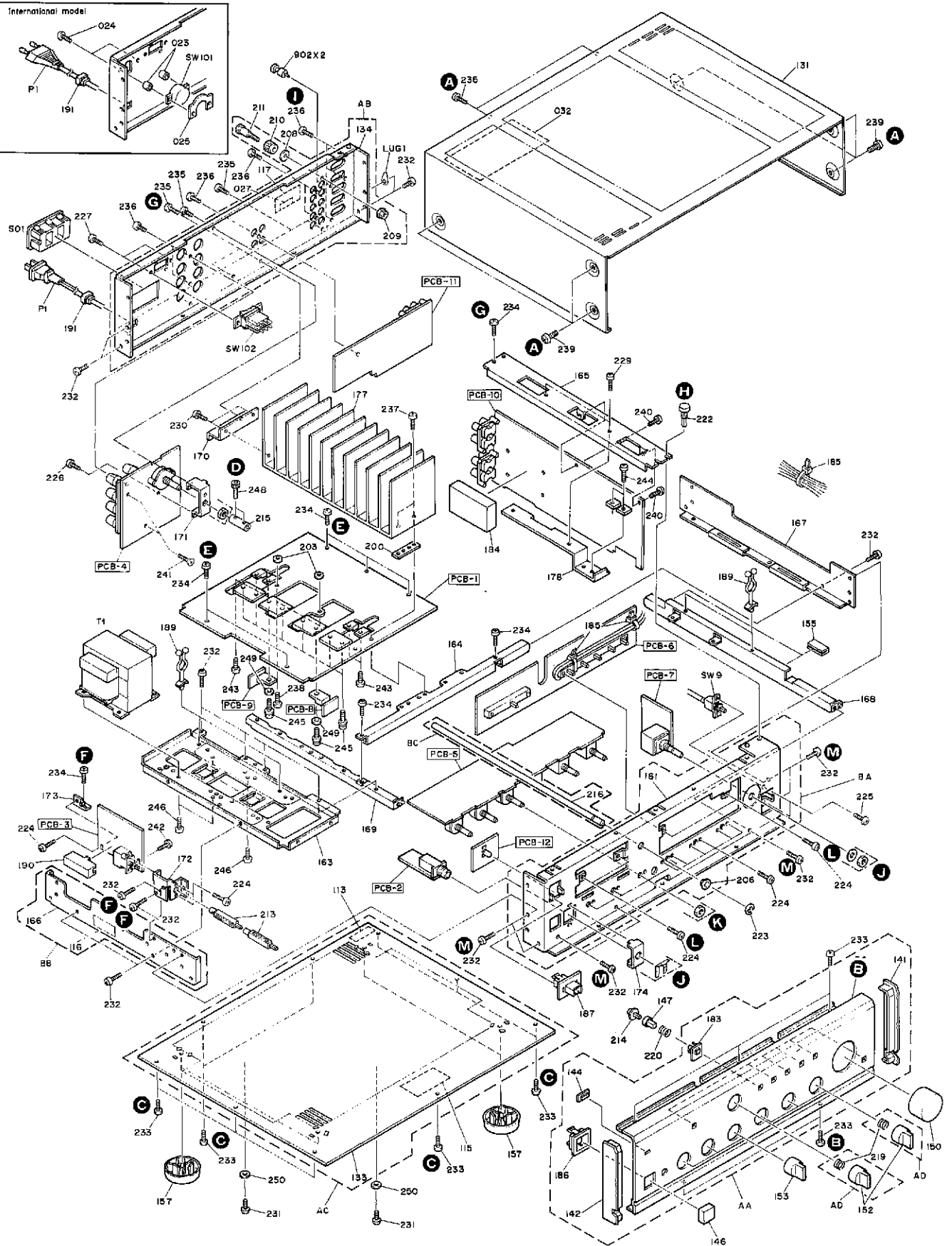
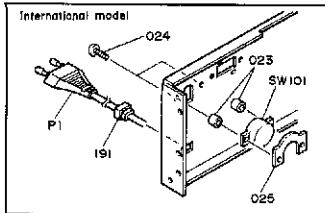

## PARTS LIST

Ref. No.	Part No.	Description	Ref. No.	Part No.	Description
AA	A443-HK6600A	FRONT PANEL ASS'Y <b>G I</b>	173	2219-8019	METAL FITTING, POWER PCB
AA	A443-HK6600B	FRONT PANEL ASS'Y <b>BK</b>	174	2219-7879	METAL FITTING, H/P
AA	A443-HK6600C	FRONT PANEL ASS'Y <b>GB</b>	177	2222-7262	HEAT SINK, MAIN <b>BK</b>
AA	A443-HK6600D	FRONT PANEL ASS'Y <b>IB</b>	177	2222-7280	HEAT SINK, MAIN <b>G GB I IB</b>
AB	A424-HK6600A	CABI BACK ASS'Y <b>BK</b>	178	2222-7183	HEAT SINK, EQ
AB	A424-HK6600B	CABI BACK ASS'Y <b>G</b>	182	2240-R0101	HOLDER, WIRING
AB	A424-HK6600C	CABI BACK ASS'Y <b>GB</b>	183	2240-7141	HOLDER <b>G I</b>
AB	A424-HK6600D	CABI BACK ASS'Y <b>I</b>	183	2240-7202	HOLDER <b>BK GB I IB</b>
AB	A424-HK6600E	CABI BACK ASS'Y <b>IB</b>	184	2240-7183	HOLDER, MC
AC	A423-HK6600A	CABI BOTTOM ASS'Y <b>BK</b>	185	2240-R0101	HOLDER, WIRING
AC	A423-HK6600B	CABI BOTTOM ASS'Y <b>G</b>	186	2240-7209	HOLDER, POWER
AC	A423-HK6600C	CABI BOTTOM ASS'Y <b>GB</b>	187	2240-7343	HOLDER, LED
AC	A423-HK6600D	CABI BOTTOM ASS'Y <b>I</b>	189	2240-7050	HOLDER, EQ/TRANS
AC	A423-HK6600E	CABI BOTTOM ASS'Y <b>IB</b>	190	2240-7176	HOLDER, FUSE
AD	A630-HK6600A	ROTARY KNOB ASS'Y <b>G I</b>	191	2240-364	HOLDER, AC CORD
AD	A630-HK6600B	ROTARY KNOB ASS'Y <b>BK</b>	200	2240-7069	INSULATOR
AD	A630-HK6600C	ROTARY KNOB ASS'Y <b>GB</b>	203	2402-0374	WASHER, PLASTIC
AD	A630-HK6600D	ROTARY KNOB ASS'Y <b>IB</b>	206	2410-100	WASHER, SPE
AE	A662-HK6600A	PUSH BUTTON ASS'Y <b>G I</b>	208	2410-7005	WASHER, SPE
AE	A662-HK6600B	PUSH BUTTON ASS'Y <b>BK</b>	209	2440-7011	NUT, SPE
AE	A662-HK6600C	PUSH BUTTON ASS'Y <b>GB</b>	210	2440-7016	NUT, SPE
AE	A662-HK6600D	PUSH BUTTON ASS'Y <b>IB</b>	211	2310-7015	SCREW, SPE
BA	B211-HK6600A	CHASSIS, FRONT	213	2672-7018	LEVER, POWER SHAFT
BB	B219-HK6600A	METAL FITTING, TRANS SIDE	214	2601-7077	SHAFT
BC	B601-HK6600A	SHAFT, SP SHAFT	215	2601-7069	SHAFT, SP
023	2132-7116	SPACER <b>G GB I IB</b>	216	2601-7131	SHAFT, SP SHAFT
024	2327-R0130124	SCREW, BND+ (3X12mm) <b>G GB I IB</b>	219	2651-110518	SPRING, SW
025	2440-7017	NUT, SPE <b>G GB I IB</b>	220	2651-210189	SPRING, PUSH BUTTON
026	1756-01413	LABEL, FUSE <b>G GB I IB</b>	222	2459-3003511	RIVET, PLASTIC
027	1756-19305	LABEL, DBP No. <b>G GB</b>	223	2461-501	STOPPER, E
032	2111-11770	FELT, TOP COVER <b>G GB I IB</b>	224	2327-R0130064	SCREW, BND+ (3X6mm)
113	1117-78	SERIAL LABEL, BOTTOM	225	2327-R0130064	SCREW, BND+ (3X6mm)
115	1751-01018	LABEL <b>BK</b>	226	2327-R0130064	SCREW, BND+ (3X6mm)
116	1756-05910	LABEL, FUSE CAUTION	227	2327-R0130064	SCREW, BND+ (3X6mm)
117	1758-CSA	LABEL <b>BK</b>	229	2327-R0130064	SCREW, BND+ (3X6mm)
131	1414-10401	CABINET, TOP	230	2347-R0130062	SCREW, BND T+ (3X6mm)
133	1423-03101	CABI BACK, BOTTOM	231	2347-R0130082	SCREW, BND T+ (3X6mm)
134	1423-29301	CABI BACK, REAR <b>BK</b>	232	2347-R0130062	SCREW, BND T+ (3X6mm)
134	1424-29302	CABI BACK, REAR <b>G GB I IB</b>	233	2347-R0130062	SCREW, BND T+ (3X6mm)
136	1443-13303	PANEL, FRONT <b>G I</b>	234	2347-R0130062	SCREW, BND T+ (3X6mm)
136	1443-13304	PANEL, FRONT <b>BK GB IB</b>	235	2347-R0130084	SCREW, BND T+ (3X6mm)
141	1562-07501	FRAME, R <b>G I</b>	236	2347-R0130084	SCREW, BND T+ (3X6mm)
141	1562-07502	FRAME, R <b>BK GB IB</b>	237	2347-R0130102	SCREW, BND T+ (3X10mm)
142	1562-07601	FRAME, L <b>G I</b>	238	2347-R0130102	SCREW, BND T+ (3X10mm)
142	1562-07602	FRAME, L <b>BK GB IB</b>	239	2347-R0140064	SCREW, BND T+ (4X6mm)
144	1732-05801	INDICATOR, PANEL	240	2347-R0130062	SCREW, BND T+ (3X6mm)
146	1660-00401	PUSH BUTTON, POWER <b>G I</b>	241	2343-300826	SCREW, CSK T+ (3X6mm)
146	1660-00403	PUSH BUTTON, POWER <b>BK GB IB</b>	242	2343-300826	SCREW, CSK T+ (3X6mm)
147	1662-05701VN	PUSH BUTTON <b>G I</b>	243	2557-301029	SCREW, B SPW+ (3X10mm)
147	1662-05702	PUSH BUTTON <b>BK GB IB</b>	244	2557-301029	SCREW, B SPW+ (3X10mm)
150	1630-03901	ROTARY KNOB, VOLUME <b>G I</b>	245	2557-301429	SCREW, B SPW+ (3X14mm)
150	1630-03902	ROTARY KNOB, VOLUME <b>BK GB IB</b>	246	2347-400827	SCREW, BND T+ (4X6mm)
152	1630-02801	ROTARY KNOB, FUNCTION <b>G I</b>	248	2396-300549	SCREW, SK HEX (3X5mm)
152	1630-02803	ROTARY KNOB, FUNCTION <b>BK GB IB</b>	249	2401-0373	WASHER, METAL
153	1630-02801	ROTARY KNOB, BASS/TREBLE/BALANCE <b>G I</b>	250	2401-0373	WASHER, METAL
153	1630-02803	ROTARY KNOB, BASS/TREBLE/BALANCE <b>BK GB IB</b>	902	4442-14	PIN PLUG
155	1568-00301	FRAME	△ T1	5584-S2511	XFORMER, POWER <b>BK</b>
157	1319-02201	LEG, BOTTOM	△ T1	5584-S2512	XFORMER, POWER <b>G GB I IB</b>
161	2211-7309	CHASSIS, FRONT	SW9	4422-70211	SWITCH, REMOTE (MC/MM)
163	2219-8007	METAL FITTING, TRANS	△ SW101	4411-102729	SWITCH, ROTARY <b>G GB I IB</b>
164	2219-8008	METAL FITTING, H,CENTER	△ SW102	4484-00101012	SWITCH, SEESAW (4/8) <b>BK</b>
165	2219-8009	METAL FITTING, EQ	△ SW102	4484-00101022	SWITCH, SEESAW (4/8) <b>G GB I IB</b>
166	2219-8010	METAL FITTING, TRANS SIDE	△ SO1	4474-156	SOCKET, AC OUTLET <b>BK</b>
167	2219-8011	METAL FITTING, EQ SIDE	△ P1	4161-71151	CORD W/PLUG <b>BK</b>
168	2219-8012	METAL FITTING, EQ CENTER	△ P1	4161-7256	CORD W/PLUG <b>G GB I IB</b>
169	2219-8013	METAL FITTING, TRANS CENTER	LUG1	4211-4	LUG <b>G GB</b>
170	2219-8014	METAL FITTING, MAIN HEAT			
171	2219-8015	METAL FITTING, SP SW			
172	2219-8016	METAL FITTING, POWER SW			

A

B

C

D

E

# P. C. BOARDS

**PCB-1** Main Driver P. C. Board

1

2

3

4

5

6

7

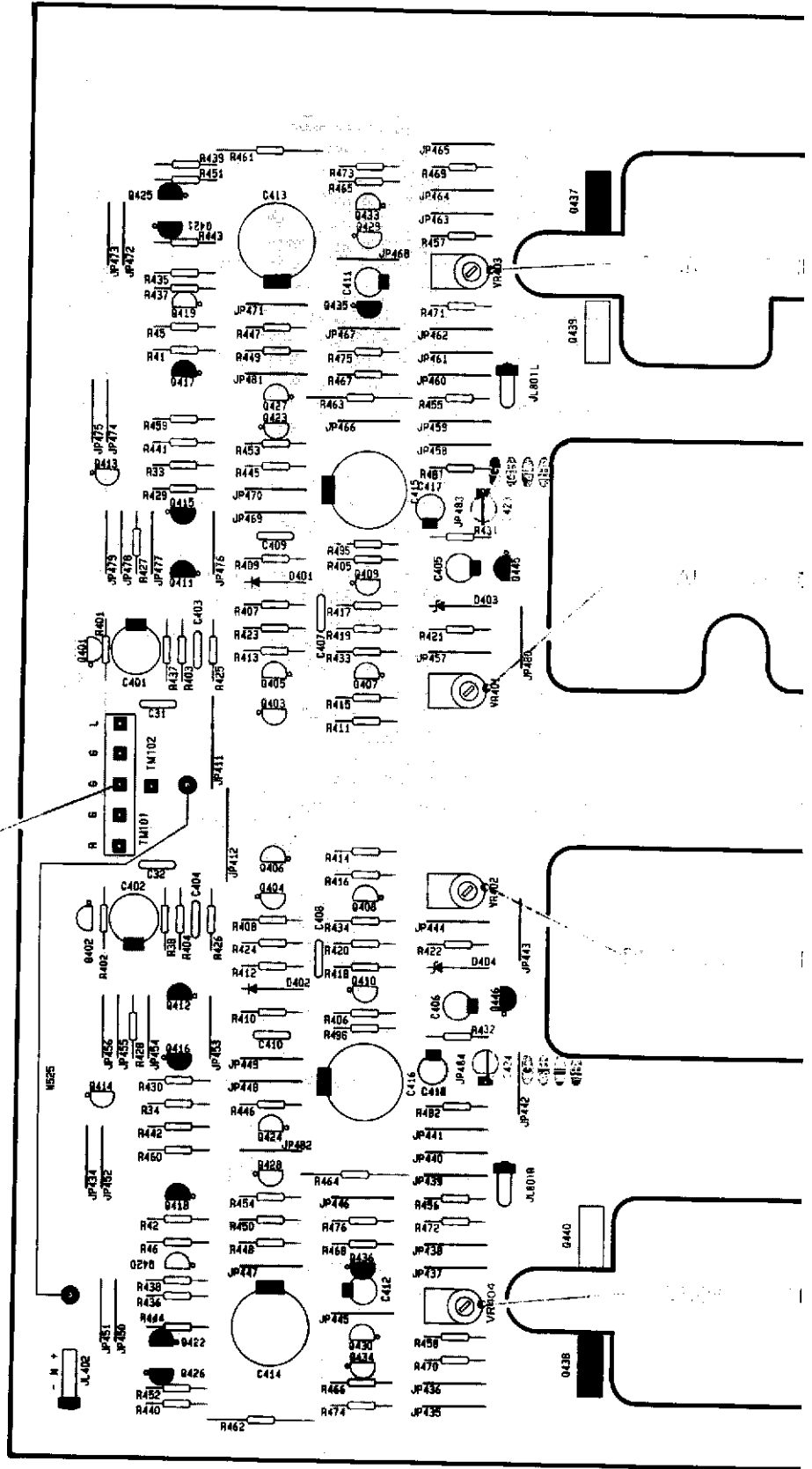

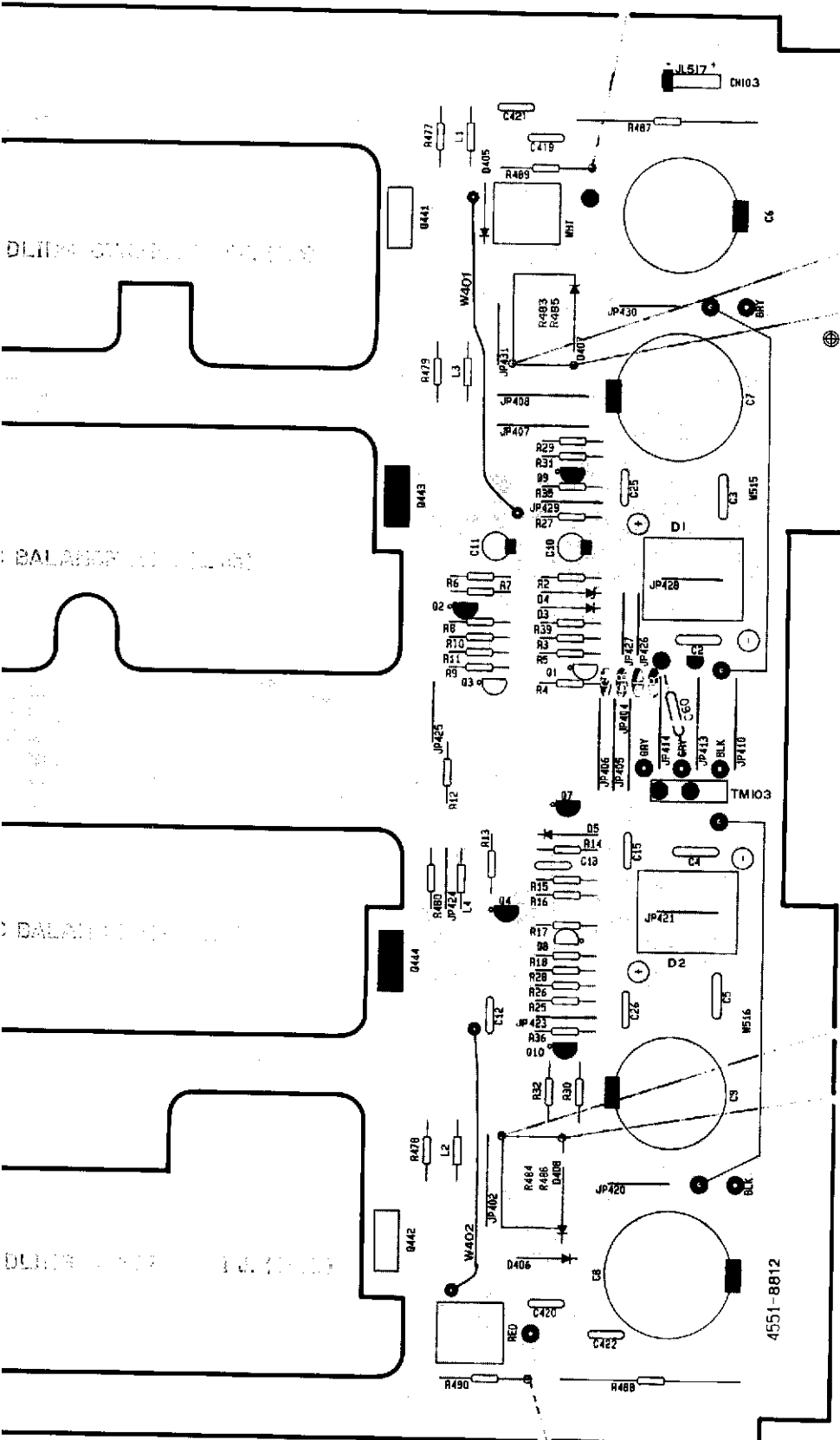

DALAM STABILISATOR

DALAM

DALAM

DALAM

4551-8812



**P. C. BOARDS**

**PCB-5** Tone 1 P. C. Board

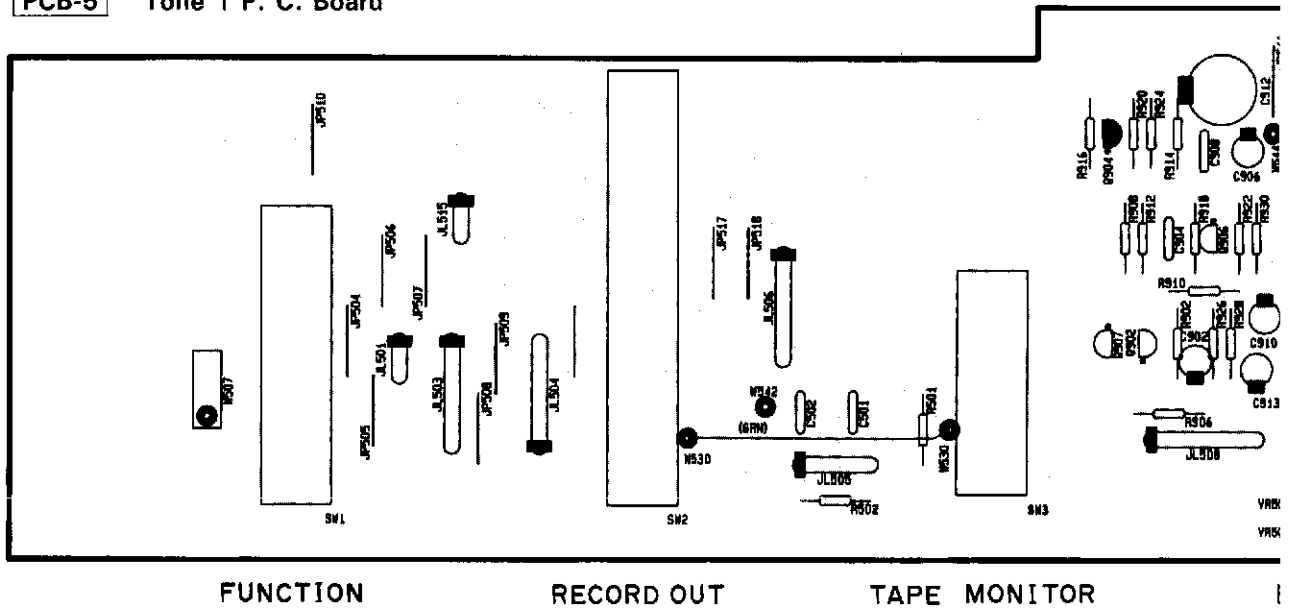

**PCB-6** Tone 2 P. C. Board

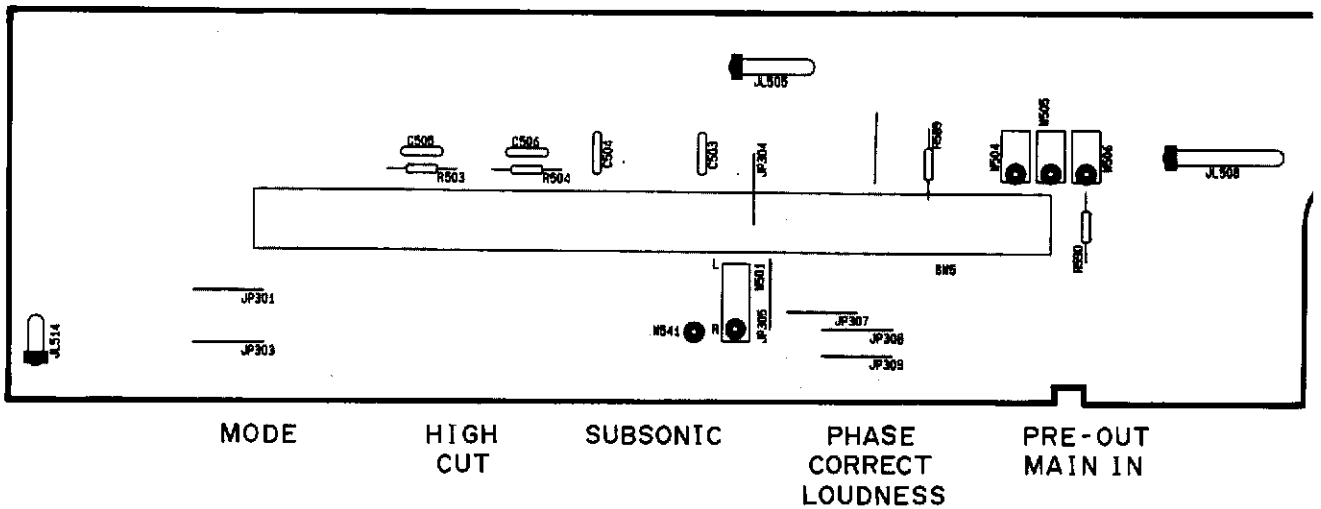

**PCB-2** Headphone P. C. Board

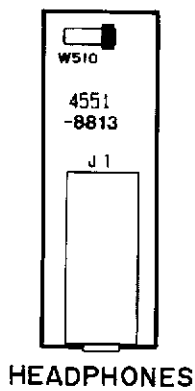

**PCB-7** Volume P. C. Board  
**VOLUME**

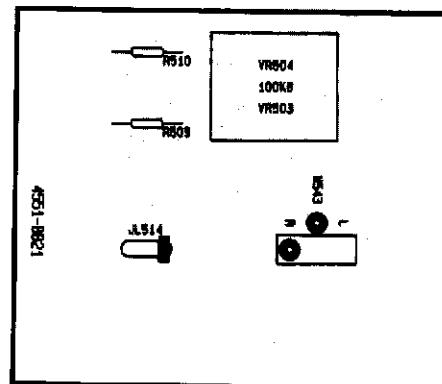

F	G	H	I	J
---	---	---	---	---

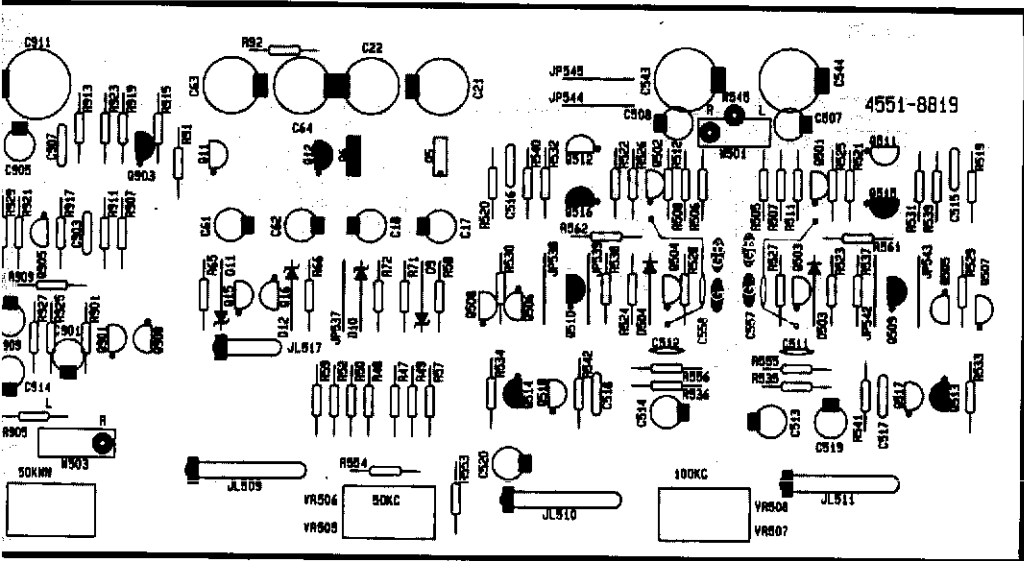

ALANCE

TREBLE

BASS

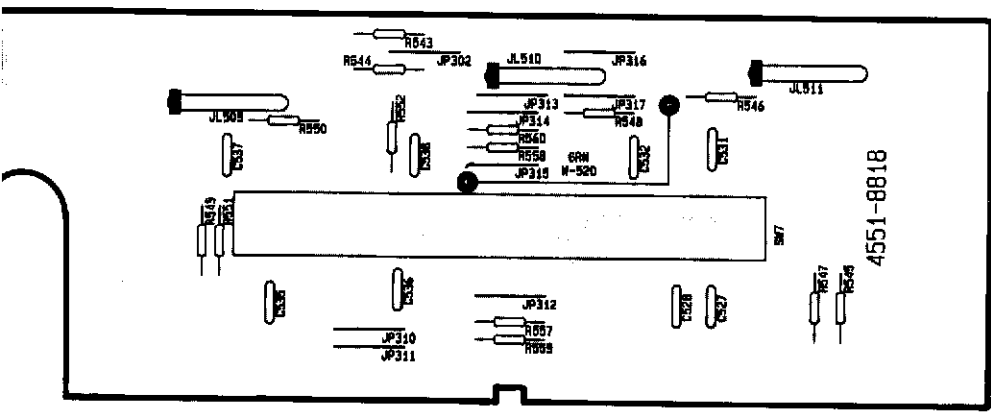

TONE DEFEAT

**PCB-8** BIAS P. C. Board (Lch)

**PCB-9** BIAS P. C. Board (Rch)

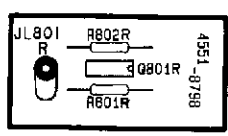
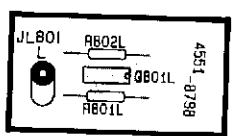

A

B

C

D

E

P. C. BOARDS

PCB-11 Pin Jack P. C. Board

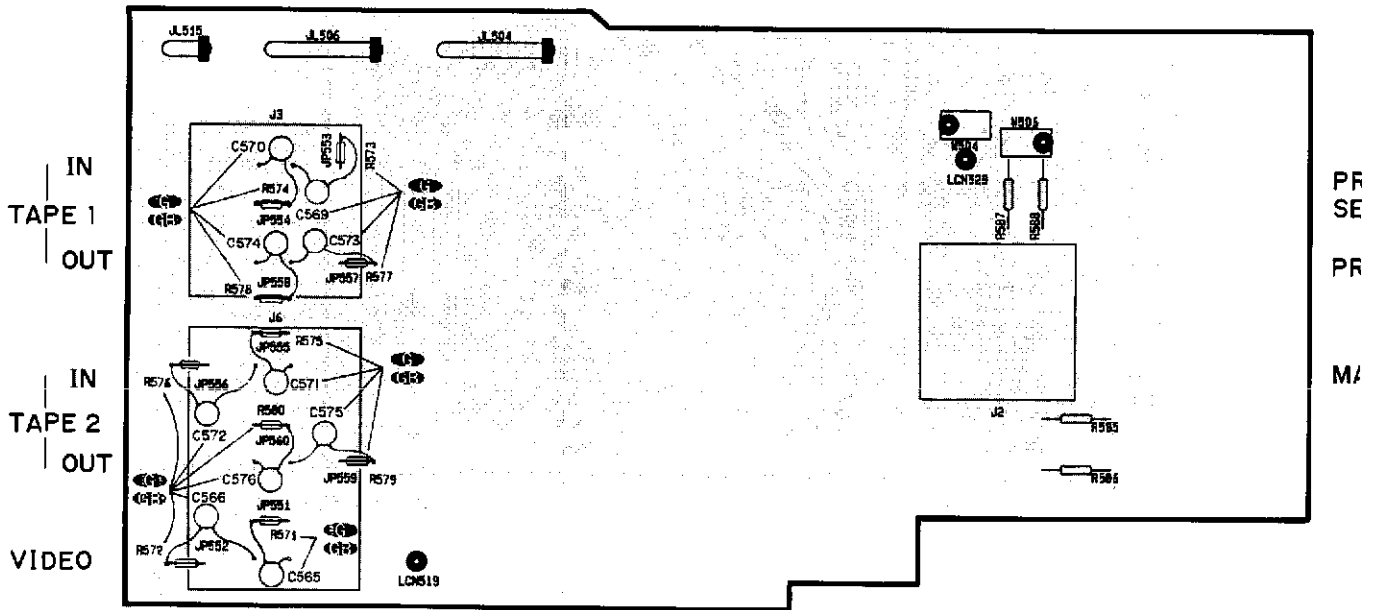

PR  
SE  
PR  
M/

PCB-10 Phono P. C. Board

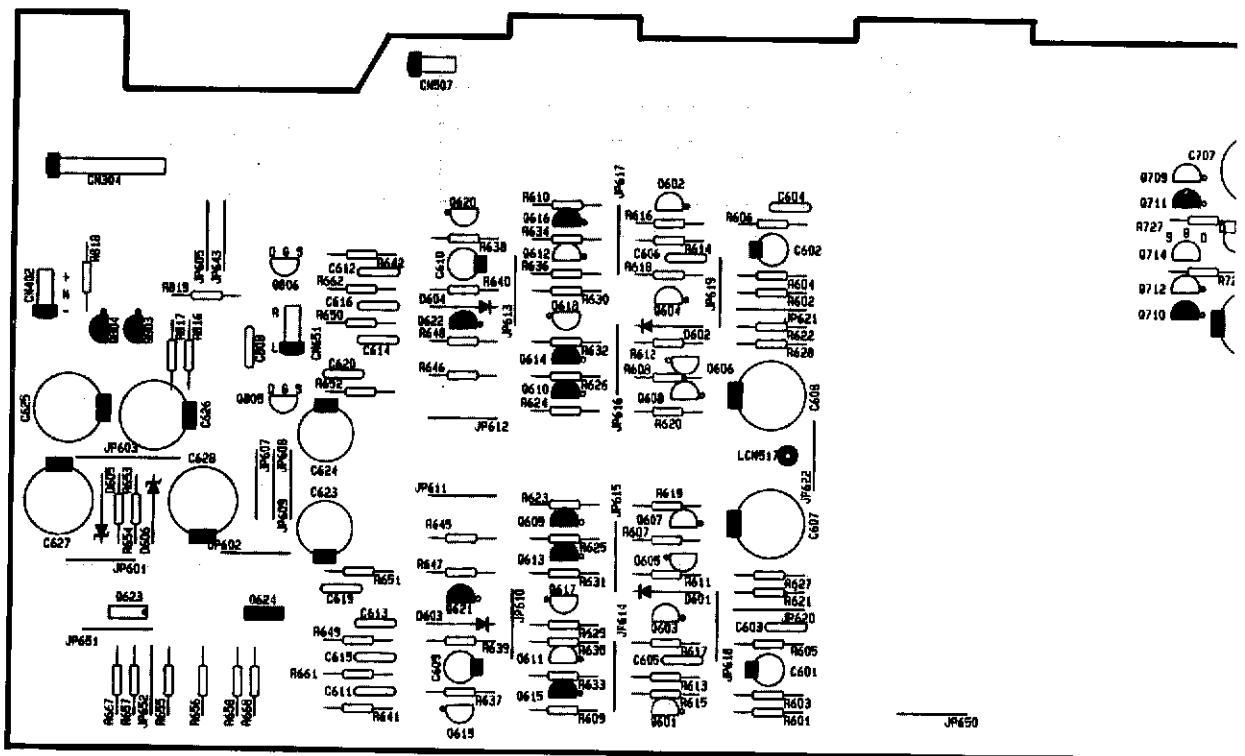

1

2

3

4

5

6

7

PCB-12 LED P. C. Board

PRE-MAIN  
SEPARATE

PRE-OUT

MAIN IN

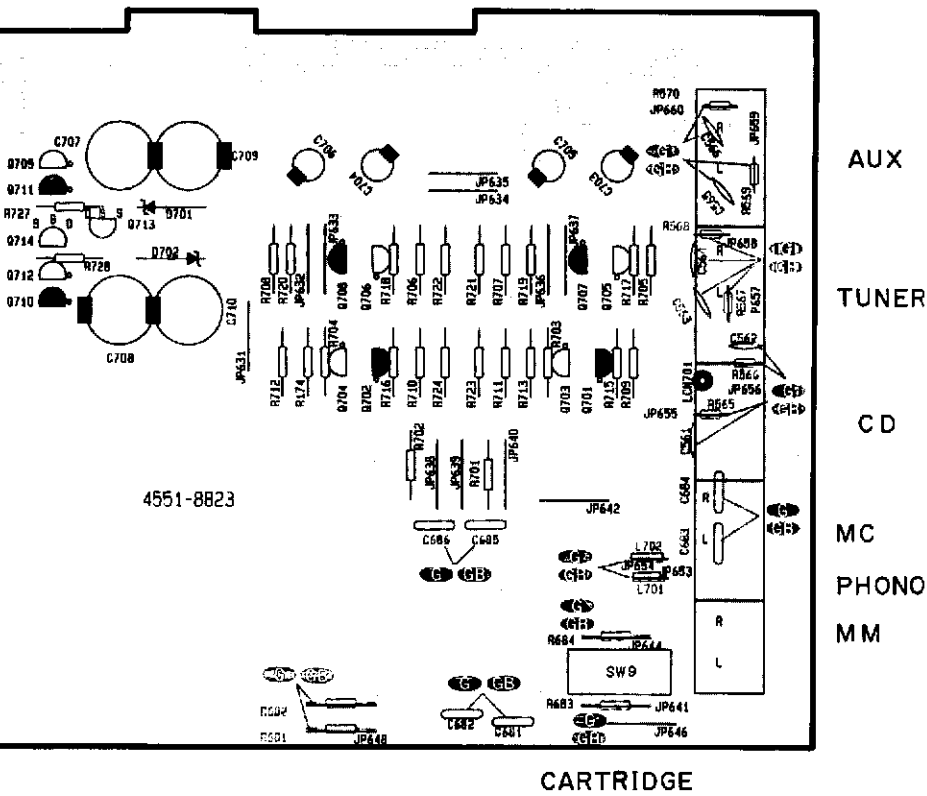
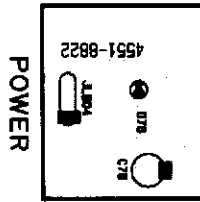

AUX  
TUNER  
CD  
MC  
PHONO  
MM

P. C. BOARDS

PCB-3 Fuse P. C. Board

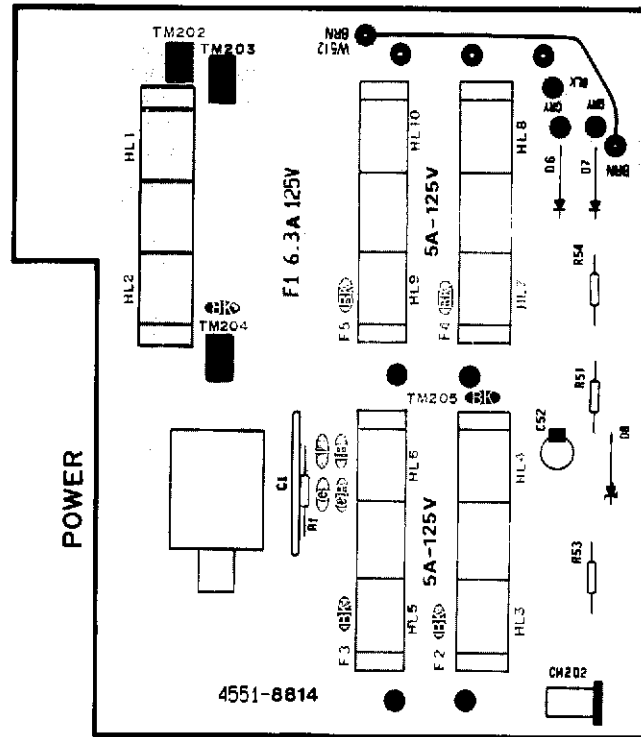

PCB-4 Speaker P. C. Board

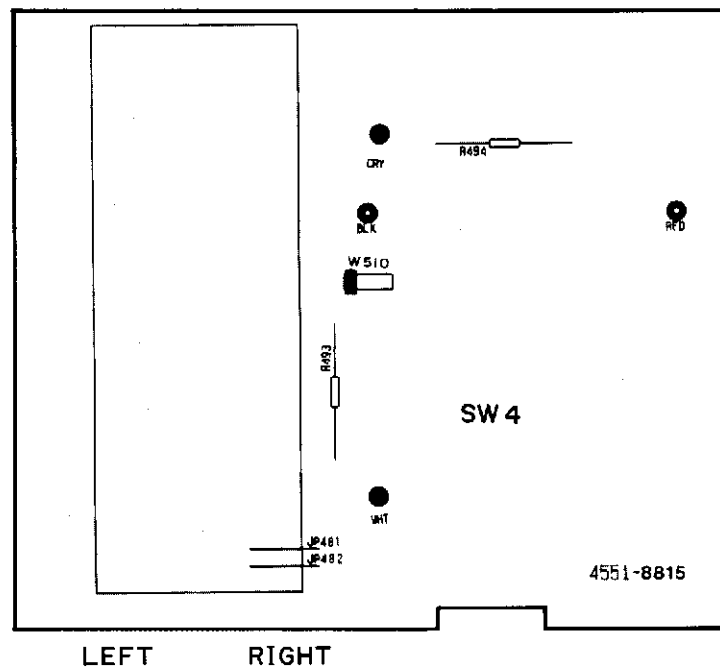

1  
2  
3  
4  
5  
6  
7

**ELECTRICAL PARTS LIST**

Ser.No	Ref. No.	Part No.	Description	Ser.No	Ref. No.	Part No.	Description
<b>PCB-1 MAIN P.C.BOARD</b>							
<b>CAPACITORS</b>							
834	C2	5352-1041957	CAP, MTL .1μ	825	R26	5135-473522	RES, CBN 1/2P 47K
834	C3	5352-1041957	CAP, MTL .1μ	828	R27	5135-472522	RES, CBN 1/2P 4.7K
834	C4	5352-1041957	CAP, MTL .1μ	828	R28	5135-472522	RES, CBN 1/2P 4.7K
834	C5	5352-1041957	CAP, MTL .1μ	828	R29	5135-472522	RES, CBN 1/2P 4.7K
840	△ C6	5341-002GM688	CAP, ELE 6800μ/63V	828	R30	5135-472522	RES, CBN 1/2P 4.7K
840	△ C7	5341-002GM688	CAP, ELE 6800μ/63V	828	R31	5135-472522	RES, CBN 1/2P 4.7K
840	△ C8	5341-002GM688	CAP, ELE 6800μ/63V	828	R32	5135-472522	RES, CBN 1/2P 4.7K
840	△ C9	5341-002GM688	CAP, ELE 6800μ/63V	826	R33	5135-223522	RES, CBN 1/2P 22K
811	C10	5345-475F0951	CAP, MINI ELE 4.7μ/50V	826	R34	5135-223522	RES, CBN 1/2P 22K
812	C11	5345-336C0951	CAP, MINI ELE 33μ/16V	817	R35	5135-332522	RES, CBN 1/2P 3.3K
813	C12	5354-334593	CAP, MYL .33μ	817	R36	5135-332522	RES, CBN 1/2P 3.3K
813	C13	5354-334593	CAP, MYL .33μ	819	R37	5135-105522	RES, CBN 1/2P 1M
816	C15	5353-330534	CAP, MCA 33p	819	R38	5135-105522	RES, CBN 1/2P 1M
815	C25	5354-683J1HM	CAP, MYL .068μ	819	R39	5135-332522	RES, CBN 1/2P 3.3K
815	C26	5354-683J1HM	CAP, MYL .068μ	826	R41	5135-223522	RES, CBN 1/2P 22K
814	C31	5354-104593	CAP, MYL .1μ	826	R42	5135-223522	RES, CBN 1/2P 22K
814	C32	5354-104593	CAP, MYL .1μ	826	R45	5135-223522	RES, CBN 1/2P 22K
062B	C60	5352-1040962	CAP, MTL .1μ <b>G GB I IB</b>	826	R46	5135-223522	RES, CBN 1/2P 22K
741	C401	5345-107B0951	CAP, MINI ELE 100μ/10V	778	R401	5135-331522	RES, CBN 1/2P 330
741	C402	5345-107B0951	CAP, MINI ELE 100μ/10V	778	R402	5135-331522	RES, CBN 1/2P 330
751	C403	5353-680534	CAP, MCA 68p	779	R403	5135-223522	RES, CBN 1/2P 22K
751	C404	5353-680534	CAP, MCA 68p	779	R404	5135-223522	RES, CBN 1/2P 22K
743	C405	5345-476D041	CAP, MINI ELE 47μ/25V	780	R405	5135-683522	RES, CBN 1/2P 68K
743	C406	5345-476D041	CAP, MINI ELE 47μ/25V	780	R406	5135-683522	RES, CBN 1/2P 68K
750	C407	5353-020934	CAP, MCA 2p	781	R407	5135-122522	RES, CBN 1/2P 1.2K
750	C408	5353-020934	CAP, MCA 2p	781	R408	5135-122522	RES, CBN 1/2P 1.2K
751	C409	5353-680534	CAP, MCA 68p	781	R409	5135-122522	RES, CBN 1/2P 1.2K
751	C410	5353-680534	CAP, MCA 68p	781	R410	5135-122522	RES, CBN 1/2P 1.2K
742	C411	5345-106F041	CAP, MINI ELE 10μ/50V	782	R411	5135-181522	RES, CBN 1/2P 180
742	C412	5345-106F041	CAP, MINI ELE 10μ/50V	782	R412	5135-181522	RES, CBN 1/2P 180
744	△ C413	5345-337G0962	CAP, MINI ELE 330μ/63V	782	R413	5135-181522	RES, CBN 1/2P 180
744	△ C414	5345-337G0962	CAP, MINI ELE 330μ/63V	782	R414	5135-181522	RES, CBN 1/2P 180
744	△ C415	5345-337G0962	CAP, MINI ELE 330μ/63V	783	R415	5135-562522	RES, CBN 1/2P 5.6K
744	△ C416	5345-337G0962	CAP, MINI ELE 330μ/63V	783	R416	5135-562522	RES, CBN 1/2P 5.6K
742	C417	5345-106F041	CAP, MINI ELE 10μ/50V <b>BK</b>	784	R417	5135-331522	RES, CBN 1/2P 330
054B	C417	5345-226F041	CAP, MINI ELE 22μ/50V <b>G GB I IB</b>	784	R418	5135-331522	RES, CBN 1/2P 330
742	C418	5345-106F041	CAP, MINI ELE 10μ/50V <b>BK</b>	785	R419	5135-393522	RES, CBN 1/2P 39K
054B	C418	5345-226F041	CAP, MINI ELE 22μ/50V <b>G GB I IB</b>	785	R420	5135-393522	RES, CBN 1/2P 39K
748	C419	5354-683J1HM	CAP, MYL .068μ	786	R421	5135-473522	RES, CBN 1/2P 47K
748	C420	5354-683J1HM	CAP, MYL .068μ	786	R422	5135-473522	RES, CBN 1/2P 47K
748	C421	5354-683J1HM	CAP, MYL .068μ	772	R423	5174-471381	RES, MTL 1/4P 470
748	C422	5354-683J1HM	CAP, MYL .068μ	772	R424	5174-471381	RES, MTL 1/4P 470
054B	C423	5345-226F041	CAP, MINI ELE 22μ/50V <b>G GB I IB</b>	771	R425	5174-220381	RES, MTL 1/4P 22
054B	C424	5345-226F041	CAP, MINI ELE 22μ/50V <b>G GB I IB</b>	771	R426	5174-220381	RES, MTL 1/4P 22
<b>RESISTORS</b>							
821	R2	5135-103522	RES, CBN 1/2P 10K	767	△ R427	5102-5615116	RES, FUSE 560
828	R3	5135-472522	RES, CBN 1/2P 4.7K	767	△ R428	5102-5615116	RES, FUSE 560
825	R4	5135-473522	RES, CBN 1/2P 47K	767	△ R429	5102-5615116	RES, FUSE 560
824	R5	5135-334522	RES, CBN 1/2P 330K	767	△ R430	5102-5615116	RES, FUSE 560
822	R6	5135-684522	RES, CBN 1/2P 680K	783	R431	5135-562522	RES, CBN 1/2P 5.6K
827	R7	5135-184522	RES, CBN 1/2P 180K	783	R432	5135-562522	RES, CBN 1/2P 5.6K
823	R8	5135-225522	RES, CBN 1/2P 2.2M	773	R433	5174-203381	RES, MTL 1/4P 20K
820	R9	5135-104522	RES, CBN 1/2P 100K	773	R434	5174-203381	RES, MTL 1/4P 20K
820	R10	5135-104522	RES, CBN 1/2P 100K	788	R435	5135-123522	RES, CBN 1/2P 12K
821	R11	5135-103522	RES, CBN 1/2P 10K	788	R436	5135-123522	RES, CBN 1/2P 12K
820	R12	5135-104522	RES, CBN 1/2P 100K	788	R437	5135-123522	RES, CBN 1/2P 12K
825	R13	5135-473522	RES, CBN 1/2P 47K	788	R438	5135-123522	RES, CBN 1/2P 12K
826	R14	5135-223522	RES, CBN 1/2P 22K	787	R439	5135-222522	RES, CBN 1/2P 2.2K
826	R15	5135-223522	RES, CBN 1/2P 22K	787	R440	5135-222522	RES, CBN 1/2P 2.2K
825	R16	5135-473522	RES, CBN 1/2P 47K	787	R441	5135-222522	RES, CBN 1/2P 2.2K
821	R17	5135-103522	RES, CBN 1/2P 10K	787	R442	5135-222522	RES, CBN 1/2P 2.2K
826	R18	5135-223522	RES, CBN 1/2P 22K	765	△ R443	5102-1515116	RES, FUSE 150
820	R25	5135-104522	RES, CBN 1/2P 100K	765	△ R444	5102-1515116	RES, FUSE 150
				765	△ R445	5102-1515116	RES, FUSE 150
				765	△ R446	5102-1515116	RES, FUSE 150
				774	R447	5174-123381	RES, MTL 1/4P 12K
				774	R448	5174-123381	RES, MTL 1/4P 12K
				774	R449	5174-123381	RES, MTL 1/4P 12K
				774	R450	5174-123381	RES, MTL 1/4P 12K
				765	△ R451	5102-1515116	RES, FUSE 150
				765	△ R452	5102-1515116	RES, FUSE 150
				765	△ R453	5102-1515116	RES, FUSE 150

Ser.No	Ref. No.	Part No.	Description
765	△ R454	5102-1515116	RES, FUSE 150
789	R455	5135-151522	RES, CBN 1/2P 150
789	R456	5135-151522	RES, CBN 1/2P 150
790	R457	5135-391522	RES, CBN 1/2P 390
790	R458	5135-391522	RES, CBN 1/2P 390
777	R459	5135-131522	RES, CBN 1/2P 130
777	R460	5135-131522	RES, CBN 1/2P 130
764	△ R461	5102-2205711	RES, FUSE 22
764	△ R462	5102-2205711	RES, FUSE 22
764	△ R463	5102-2205711	RES, FUSE 22
764	△ R464	5102-2205711	RES, FUSE 22
766	△ R465	5102-1015116	RES, FUSE 100
766	△ R466	5102-1015116	RES, FUSE 100
766	△ R467	5102-1015116	RES, FUSE 100
766	△ R468	5102-1015116	RES, FUSE 100
768	△ R469	5102-2R25116	RES, FUSE 2.2
768	△ R470	5102-2R25116	RES, FUSE 2.2
768	△ R471	5102-2R25116	RES, FUSE 2.2
768	△ R472	5102-2R25116	RES, FUSE 2.2
791	R473	5135-150522	RES, CBN 1/2P 15
791	R474	5135-150522	RES, CBN 1/2P 15
791	R475	5135-150522	RES, CBN 1/2P 15
791	R476	5135-150522	RES, CBN 1/2P 15
792	R477	5135-100522	RES, CBN 1/2P 10
792	R478	5135-100522	RES, CBN 1/2P 10
792	R479	5135-100522	RES, CBN 1/2P 10
792	R480	5135-100522	RES, CBN 1/2P 10
793	△ R481	5102-6805116	RES, FUSE 68
793	△ R482	5102-6805116	RES, FUSE 68
755	R483/ 485	5275-R27671	RES, CEM 5P .27
755	R484/ 486	5275-R27671	RES, CEM 5P .27
756	R487	5175-150571	RES, MTL 3P 15
756	R488	5175-150571	RES, MTL 3P 15
757	R489	5171-220572	RES, MTL 1P 22
757	R490	5171-220572	RES, MTL 1P 22
776	R495	5135-223522	RES, CBN 1/2P 22K
776	R496	5135-223522	RES, CBN 1/2P 22K

**TRANSISTORS**

801	Q1	5613-1740S(S)	XISTOR, NPN R
802	Q2	5611-933(S)	XISTOR, PNP R
801	Q3	5613-1740S(S)	XISTOR, NPN R
802	Q4	5611-933(S)	XISTOR, PNP R
802	Q7	5611-933(S)	XISTOR, PNP R
803	Q8	5613-1845(E)	XISTOR, NPN R
804	Q9	5611-970(BL)	XISTOR, PNP R
804	Q10	5611-970(BL)	XISTOR, PNP R
805	Q401	5616-2SK364(V)	FET, N-CH
805	Q402	5616-2SK364(V)	FET, N-CH
711	Q403	5613-2240(BL)	XISTOR, NPN R
711	Q404	5613-2240(BL)	XISTOR, NPN R
711	Q405	5613-2240(BL)	XISTOR, NPN R
711	Q406	5613-2240(BL)	XISTOR, NPN R
715	Q407	5613-2320L(F)	XISTOR, NPN R
715	Q408	5613-2320L(F)	XISTOR, NPN R
715	Q409	5613-2320L(F)	XISTOR, NPN R
715	Q410	5613-2320L(F)	XISTOR, NPN R
717	Q411	5611-1145(Y)	XISTOR, PNP R
717	Q412	5611-1145(Y)	XISTOR, PNP R
714	Q413	5613-2240(BL)	XISTOR, NPN R
714	Q414	5613-2240(BL)	XISTOR, NPN R
712	Q415	5611-970(BL)	XISTOR, PNP R
712	Q416	5611-970(BL)	XISTOR, PNP R
713	Q417	5611-992(E)	XISTOR, PNP R
713	Q418	5611-992(E)	XISTOR, PNP R
714	Q419	5613-2240(BL)	XISTOR, NPN R
714	Q420	5613-2240(BL)	XISTOR, NPN R
735	Q421	5611-1285(F)	XISTOR, PNP R
735	Q422	5611-1285(F)	XISTOR, PNP R

Ser.No	Ref. No.	Part No.	Description
716	Q423	5613-3245(F)	XISTOR, NPN R
716	Q424	5613-3245(F)	XISTOR, NPN R
735	Q425	5611-1285(F)	XISTOR, PNP R
735	Q426	5611-1285(F)	XISTOR, PNP R
716	Q427	5613-3245(F)	XISTOR, NPN R
716	Q428	5613-3245(F)	XISTOR, NPN R
720	Q429	5613-945(P)	XISTOR, NPN R
720	Q430	5613-945(P)	XISTOR, NPN R
718	Q433	5613-2235(Y)	XISTOR, NPN R
718	Q434	5613-2235(Y)	XISTOR, NPN R
719	Q435	5611-965(Y)	XISTOR, PNP R
719	Q436	5611-965(Y)	XISTOR, PNP R
724	Q437	5611-1306(Y)	XISTOR, PNP R
724	Q438	5611-1306(Y)	XISTOR, PNP R
721	Q439	5613-3296(Y)	XISTOR, NPN R
721	Q440	5613-3296(Y)	XISTOR, NPN R
727	Q441	5613-3858(Y)	XISTOR, NPN R
727	Q442	5613-3858(Y)	XISTOR, NPN R
729	Q443	5611-1494(Y)	XISTOR, PNP R
729	Q444	5611-1494(Y)	XISTOR, PNP R
712	Q445	5611-970(BL)	XISTOR, PNP R
712	Q446	5611-970(BL)	XISTOR, PNP R

**DIODES**

839	△ D1	5685-D5FB20F1	SILICON, BRIG
839	△ D2	5685-D5FB20F1	SILICON, BRIG
808	D3	5636-1S2471	DIODE, SWITCH
807	D4	5635-HZ6A-2L	DIODE, ZENER
809	D5	5631-1S2473	DIODE, DET
732	D401	5631-1S2473	DIODE, DET
732	D402	5631-1S2473	DIODE, DET
733	D403	5635-HZ15-1L	DIODE, ZENER
733	D404	5635-HZ15-1L	DIODE, ZENER
734	D405	5632-10DF2	DIODE, RECT
734	D406	5632-10DF2	DIODE, RECT
734	D407	5632-10DF2	DIODE, RECT
734	D408	5632-10DF2	DIODE, RECT

**COILS**

738	L1	5597-35502	CORE, BEADS
738	L2	5597-35502	CORE, BEADS
738	L3	5597-35502	CORE, BEADS
738	L4	5597-35502	CORE, BEADS
737	L5	5991-7165	SPRING COIL
737	L6	5991-7165	SPRING COIL

**CONTROLS**

761	VR401	5101-50371920	RES, SEMI FIX 50K
761	VR402	5101-50371920	RES, SEMI FIX 50K
762	VR403	5101-50171913	RES, SEMI FIX 500
762	VR404	5101-50171913	RES, SEMI FIX 500

**MISCELLANEOUS**

913	CN103	4443-040185	CONNECTOR
952	JL402	4242-R0203351	JUMPER LEAD
938	JL801(L)	4132-R0202141	CORD, 2C
936	JL801(R)	4132-R0202141	CORD, 2C
796	LCN511	4163-0115024	CONNECTOR W/W
797	LCN512	4163-0120025	CONNECTOR W/W
798	LCN513	4163-0137026	CONNECTOR W/W
799	LCN514	4163-0143027	CONNECTOR W/W
795	LCN515	4163-0111024	CONNECTOR W/W
795	LCN516	4163-0111024	CONNECTOR W/W
918	TM101	4214-11033	TERMINAL
919	TM102	4214-11013	TERMINAL
920	TM103	4214-11013	TERMINAL <b>BK</b>
920B	TM103	4214-11031	TERMINAL <b>G GB I IB</b>

**PCB-2 HEADPHONE P.C.BOARD**

MISCELLANEOUS			
886	J1	4451-00159	JACK, 1P

Ser.No	Ref. No.	Part No.	Description
<b>PCB-3 FUSE P.C. BOARD</b>			
<b>CAPACITORS</b>			
833	△ C1	5352-1030959	CAP, MTL .01μ <b>BK</b>
833B	△ C1	5352-1030958	CAP, MTL .01μ <b>G GB I IB</b>
847	C52	5345-106C0951	CAP, MINI ELE 10μ/16V
<b>RESISTORS</b>			
042B	△ R1	5135-335522	RES, CBN 1/2P 3.3M <b>G GB I IB</b>
850	R51	5135-152522	RES, CBN 1/2P 1.5K
849	R53	5135-391522	RES, CBN 1/2P 390
850	R54	5135-152522	RES, CBN 1/2P 1.5K
<b>DIODES</b>			
843	△ D6	5632-S5566B	DIODE, RECT
843	△ D7	5632-S5566B	DIODE, RECT
844	D8	5635-HZ6A-2L	DIODE, ZENER
<b>MISCELLANEOUS</b>			
915	CN202	4443-030185	CONNECTOR
836	△ HL1	4472-7113	HOLDER, FUSE <b>BK</b>
836B	△ HL1	4472-7122	HOLDER, FUSE <b>G GB I IB</b>
838	△ HL2	4472-7113	HOLDER, FUSE <b>BK</b>
838B	△ HL2	4472-7122	HOLDER, FUSE <b>G GB I IB</b>
838	△ HL3	4472-7113	HOLDER, FUSE <b>BK</b>
838	△ HL4	4472-7113	HOLDER, FUSE <b>BK</b>
838	△ HL5	4472-7113	HOLDER, FUSE <b>BK</b>
838	△ HL6	4472-7113	HOLDER, FUSE <b>BK</b>
838	△ HL7	4472-7113	HOLDER, FUSE <b>BK</b>
838	△ HL8	4472-7113	HOLDER, FUSE <b>BK</b>
838	△ HL9	4472-7113	HOLDER, FUSE <b>BK</b>
838	△ HL10	4472-7113	HOLDER, FUSE <b>BK</b>
861	△ SW8	4431-01018158	SWITCH, PUSH
898	TM202	4214-122	TERMINAL
898	TM203	4214-122	TERMINAL
898	TM204	4214-122	TERMINAL <b>BK</b>
922	TM205	4214-11023	TERMINAL <b>BK</b>

Ser.No	Ref. No.	Part No.	Description
<b>PCB-4 SPEAKER P.C. BOARD</b>			
<b>RESISTORS</b>			
759	R493	5171-471572	RES, MTL 1P 470
759	R494	5171-471572	RES, MTL 1P 470
<b>MISCELLANEOUS</b>			
897	△ TM901	4214-156	TERMINAL
873	SW4	4411-1047110	SWITCH, ROTARY

Ser.No	Ref. No.	Part No.	Description
<b>PCB-5 TONE 1 P.C. BOARD</b>			
<b>CAPACITORS</b>			
699	C17	5345-337D041	CAP, MINI ELE 330μ/25V
699	C18	5345-337D041	CAP, MINI ELE 330μ/25V
700	C21	5345-227D041	CAP, MINI ELE 220μ/25V
700	C22	5345-227D041	CAP, MINI ELE 220μ/25V
701	C61	5345-107D041	CAP, MINI ELE 100μ/25V
701	C62	5345-107D041	CAP, MINI ELE 100μ/25V
700	C63	5345-227D041	CAP, MINI ELE 220μ/25V
700	C64	5345-227D041	CAP, MINI ELE 220μ/25V
634	C501	5359-1015851	CAP, PPP 100p
634	C502	5359-1015851	CAP, PPP 100p
630	C507	5345-106C0951	CAP, MINI ELE 10μ/16V
630	C508	5345-106C0951	CAP, MINI ELE 10μ/16V
637	C511	5353-010934	CAP, MCA 1p
637	C512	5353-010934	CAP, MCA 1P
631	C513	5345-226D0951	CAP, MINI ELE 22μ/25V
631	C514	5345-226D0951	CAP, MINI ELE 22μ/25V
638	C515	5353-680534	CAP, MCA 68p
638	C516	5353-680534	CAP, MCA 68p
638	C517	5353-680534	CAP, MCA 68p

Ser.No	Ref. No.	Part No.	Description
638	C518	5353-680534	CAP, MCA 68p
632	C519	5345-476C0951	CAP, MINI ELE 47μ/16V
632	C520	5345-476C0951	CAP, MINI ELE 47μ/16V
629	C543	5345-227D041	CAP, MINI ELE 220μ/25V
629	C544	5345-227D041	CAP, MINI ELE 220μ/25V
066B	C557	5361-101KB	CAP, CER 100p <b>G GB</b>
066B	C558	5361-101KB	CAP, CER 100p <b>G GB</b>
595	C901	5345-104F0951	CAP, MINI ELE .1μ/50V
595	C902	5345-104F0951	CAP, MINI ELE .1μ/50V
599	C903	5354-154593	CAP, MYL .15μ
599	C904	5354-154593	CAP, MYL .15μ
597	C905	5345-107D045	CAP, MINI ELE 100μ/25V
597	C906	5345-107D045	CAP, MINI ELE 100μ/25V
600	C907	5354-334593	CAP, MYL .33μ
600	C908	5354-334593	CAP, MYL .33μ
596	C909	5345-474F0951	CAP, MINI ELE .47μ/50V
596	C910	5345-474F0951	CAP, MINI ELE .47μ/50V
594	C911	5345-227D041	CAP, MINI ELE 220μ/25V
594	C912	5345-227D041	CAP, MINI ELE 220μ/25V
596	C913	5345-474F0951	CAP, MINI ELE .47μ/50V
596	C914	5345-474F0951	CAP, MINI ELE .47μ/50V
<b>RESISTORS</b>			
702	△ R47	5102-1015116	RES, FUSE 100 <b>BK</b>
702B	R47	5135-181522	RES, CBN 1/2P 180 <b>G GB I IB</b>
702	△ R48	5102-1015116	RES, FUSE 100 <b>BK</b>
702B	R48	5135-181522	RES, CBN 1/2P 180 <b>G GB I IB</b>
704	R49	5176-S010J151	RES, MTL 1/2P 150 <b>BK</b>
704B	R49	5135-181522	RES, CBN 1/2P 180 <b>G GB I IB</b>
704	R50	5176-S010J151	RES, MTL 1/2P 150 <b>BK</b>
704B	R50	5135-181522	RES, CBN 1/2P 180 <b>G GB I IB</b>
704	R52	5176-S010J151	RES, MTL 1/2P 150 <b>BK</b>
704B	R52	5135-181522	RES, CBN 1/2P 180 <b>G GB I IB</b>
704	R57	5176-S010J151	RES, MTL 1/2P 150 <b>BK</b>
704B	R57	5135-181522	RES, CBN 1/2P 180 <b>G GB I IB</b>
704	R58	5176-S010J151	RES, MTL 1/2P 150 <b>BK</b>
704B	R58	5135-181522	RES, CBN 1/2P 180 <b>G GB I IB</b>
704	R59	5176-S010J151	RES, MTL 1/2P 150 <b>BK</b>
704B	R59	5135-181522	RES, CBN 1/2P 180 <b>G GB I IB</b>
703	△ R65	5102-8215116	RES, FUSE 820
703	△ R66	5102-8215116	RES, FUSE 820
706	R71	5135-822522	RES, CBN 1/2P 8.2K
706	R72	5135-822522	RES, CBN 1/2P 8.2K
708	△ R91	5102-1015116	RES, FUSE 100
708	△ R92	5102-1015116	RES, FUSE 100
651	R501	5135-102522	RES, CBN 1/2P 1K
651	R502	5135-102522	RES, CBN 1/2P 1K
653	R505	5135-224522	RES, CBN 1/2P 220K
653	R506	5135-224522	RES, CBN 1/2P 220K
652	R507	5135-394522	RES, CBN 1/2P 390K
652	R508	5135-394522	RES, CBN 1/2P 390K
670	R511	5135-331522	RES, CBN 1/2P 330
670	R512	5135-331522	RES, CBN 1/2P 330
654	R519	5135-473522	RES, CBN 1/2P 47K
654	R520	5135-473522	RES, CBN 1/2P 47K
655	R521	5135-332522	RES, CBN 1/2P 3.3K
655	R522	5135-332522	RES, CBN 1/2P 3.3K
655	R523	5135-332522	RES, CBN 1/2P 3.3K
655	R524	5135-332522	RES, CBN 1/2P 3.3K
656	R525	5135-471522	RES, CBN 1/2P 470
656	R526	5135-471522	RES, CBN 1/2P 470
656	R527	5135-471522	RES, CBN 1/2P 470
656	R528	5135-471522	RES, CBN 1/2P 470
657	R529	5135-331522	RES, CBN 1/2P 330
657	R530	5135-331522	RES, CBN 1/2P 330
658	R531	5135-222522	RES, CBN 1/2P 2.2K
658	R532	5135-222522	RES, CBN 1/2P 2.2K
658	R533	5135-222522	RES, CBN 1/2P 2.2K
658	R534	5135-222522	RES, CBN 1/2P 2.2K
659	R535	5135-274522	RES, CBN 1/2P 270K
659	R536	5135-274522	RES, CBN 1/2P 270K
660	R537	5135-153522	RES, CBN 1/2P 15K



Ser.No	Ref. No.	Part No.	Description
660	R538	5135-153522	RES, CBN 1/2P 15K
657	R539	5135-331522	RES, CBN 1/2P 330
657	R540	5135-331522	RES, CBN 1/2P 330
657	R541	5135-331522	RES, CBN 1/2P 330
657	R542	5135-331522	RES, CBN 1/2P 330
661	R553	5135-121522	RES, CBN 1/2P 120
661	R554	5135-121522	RES, CBN 1/2P 120
654	R555	5135-473522	RES, CBN 1/2P 47K
654	R556	5135-473522	RES, CBN 1/2P 47K
658	R561	5135-222522	RES, CBN 1/2P 2.2K
658	R562	5135-222522	RES, CBN 1/2P 2.2K
611	R901	5135-102522	RES, CBN 1/2P 1K
611	R902	5135-102522	RES, CBN 1/2P 1K
610	R905	5135-104522	RES, CBN 1/2P 100K
610	R906	5135-104522	RES, CBN 1/2P 100K
604	R907	5135-332522	RES, CBN 1/2P 3.3K
604	R908	5135-332522	RES, CBN 1/2P 3.3K
604	R909	5135-332522	RES, CBN 1/2P 3.3K
604	R910	5135-332522	RES, CBN 1/2P 3.3K
605	R911	5135-183522	RES, CBN 1/2P 18K
605	R912	5135-183522	RES, CBN 1/2P 18K
606	R913	5135-472522	RES, CBN 1/2P 4.7K
606	R914	5135-472522	RES, CBN 1/2P 4.7K
608	R915	5135-562522	RES, CBN 1/2P 5.6K
608	R916	5135-562522	RES, CBN 1/2P 5.6K
604	R917	5135-332522	RES, CBN 1/2P 3.3K
604	R918	5135-332522	RES, CBN 1/2P 3.3K
606	R919	5135-472522	RES, CBN 1/2P 4.7K
606	R920	5135-472522	RES, CBN 1/2P 4.7K
607	R921	5135-331522	RES, CBN 1/2P 330
607	R922	5135-331522	RES, CBN 1/2P 330
604	R923	5135-332522	RES, CBN 1/2P 3.3K
604	R924	5135-332522	RES, CBN 1/2P 3.3K
609	R925	5135-221522	RES, CBN 1/2P 220
609	R926	5135-221522	RES, CBN 1/2P 220
607	R927	5135-331522	RES, CBN 1/2P 330
607	R928	5135-331522	RES, CBN 1/2P 330
610	R929	5135-104522	RES, CBN 1/2P 100K
610	R930	5135-104522	RES, CBN 1/2P 100K

**TRANSISTORS**

691	Q5	5614-1266(P)	XISTOR, NPN A
692	Q6	5612-941(P)	XISTOR, PNP A
693	Q11	5614-667A(C)	XISTOR, NPN A
694	Q12	5612-647A(C)	XISTOR, PNP A
695	Q15	5616-2SK373(Y)	FET, N-CH
695	Q16	5616-2SK373(Y)	FET, N-CH
621	Q501	5613-2320L(F)	XISTOR, NPN R
621	Q502	5613-2320L(F)	XISTOR, NPN R
621	Q503	5613-2320L(F)	XISTOR, NPN R
621	Q504	5613-2320L(F)	XISTOR, NPN R
622	Q505	5613-2320L(F)	XISTOR, NPN R
622	Q506	5613-2320L(F)	XISTOR, NPN R
622	Q507	5613-2320L(F)	XISTOR, NPN R
622	Q508	5613-2320L(F)	XISTOR, NPN R
623	Q509	5611-999L(F)	XISTOR, PNP R
623	Q510	5611-999L(F)	XISTOR, PNP R
622	Q511	5613-2320L(F)	XISTOR, NPN R
622	Q512	5613-2320L(F)	XISTOR, NPN R
623	Q513	5611-999L(F)	XISTOR, PNP R
623	Q514	5611-999L(F)	XISTOR, PNP R
625	Q515	5612-647(C)	XISTOR, PNP A
625	Q516	5612-647(C)	XISTOR, PNP A
624	Q517	5614-667(C)	XISTOR, NPN A
624	Q518	5614-667(C)	XISTOR, NPN A
591	Q901	5613-2240(BL)	XISTOR, NPN R
591	Q902	5613-2240(BL)	XISTOR, NPN R
592	Q903	5611-970(BL)	XISTOR, PNP R
592	Q904	5611-970(BL)	XISTOR, PNP R
591	Q905	5613-2240(BL)	XISTOR, NPN R
591	Q906	5613-2240(BL)	XISTOR, NPN R
593	Q907	5616-2SK246(Y)	FET, N-CH

Ser.No	Ref. No.	Part No.	Description
593	Q908	5616-2SK246(Y)	FET, N-CH
<b>DIODES</b>			
696	D9	5635-HZ24-2L	DIODE, ZENER
696	D10	5635-HZ24-2L	DIODE, ZENER
697	D11	5635-HZ15-2L	DIODE, ZENER
697	D12	5635-HZ15-2L	DIODE, ZENER
627	D503	5631-1S2473	DIODE, DET
627	D504	5631-1S2473	DIODE, DET
<b>CONTROLS</b>			
883	VR501/ 502	5113-50396122	RES, V CBN 16 50K
879	VR505/ 506	5113-50373148	RES, V CBN 16 50K
881	VR507/ 508	5113-10474148	RES, V CBN 16 100K
<b>MISCELLANEOUS</b>			
939	JL501	4242-R0403201	JUMPER LEAD
941	JL503	4242-R0407181	JUMPER LEAD
942	JL504	4242-R0307551	JUMPER LEAD
943	JL505	4242-R0305900	JUMPER LEAD
944	JL506	4242-R0307551	JUMPER LEAD
940	JL508	4242-R0307800	JUMPER LEAD
940	JL509	4242-R0307800	JUMPER LEAD
940	JL510	4242-R0307800	JUMPER LEAD
940	JL511	4242-R0307800	JUMPER LEAD
946	JL515	4242-R0303501	JUMPER LEAD
949	JL517	4242-R0404181	JUMPER LEAD
867	SW1	4424-00102045	SWITCH, RO-SL
868	SW2	4424-00103065	SWITCH, RO-SL
869	SW3	4424-00101043	SWITCH, RO-SL

**PCB-6 TONE 2 P.C.BOARD**

**CAPACITORS**

613	C503	5354-394593	CAP, MYL .39μ
613	C504	5354-394593	CAP, MYL .39μ
614	C505	5354-183J1HM	CAP, MYL .018μ
614	C506	5354-183J1HM	CAP, MYL .018μ
642	C527	5354-183J1HM	CAP, MYL .018μ
642	C528	5354-183J1HM	CAP, MYL .018μ
641	C531	5354-104593	CAP, MYL .1μ
641	C532	5354-104593	CAP, MYL .1μ
647	C535	5354-682J1HM	CAP, MYL 6800p
647	C536	5354-682J1HM	CAP, MYL 6800p
648	C537	5354-393J1HM	CAP, MYL .039μ
648	C538	5354-393J1HM	CAP, MYL .039μ

**RESISTORS**

616	R503	5135-105522	RES, CBN 1/2P 1M
616	R504	5135-105522	RES, CBN 1/2P 1M
672	R543	5135-331522	RES, CBN 1/2P 330
672	R544	5135-331522	RES, CBN 1/2P 330
667	R545	5135-153522	RES, CBN 1/2P 15K
667	R546	5135-153522	RES, CBN 1/2P 15K
662	R547	5135-272522	RES, CBN 1/2P 2.7K
662	R548	5135-272522	RES, CBN 1/2P 2.7K
666	R549	5135-331522	RES, CBN 1/2P 330
666	R550	5135-331522	RES, CBN 1/2P 330
669	R551	5135-122522	RES, CBN 1/2P 1.2K
669	R552	5135-122522	RES, CBN 1/2P 1.2K
667	R557	5135-153522	RES, CBN 1/2P 15K
667	R558	5135-153522	RES, CBN 1/2P 15K
668	R559	5135-272522	RES, CBN 1/2P 2.7K
668	R560	5135-272522	RES, CBN 1/2P 2.7K
671	R589	5135-391522	RES, CBN 1/2P 390
671	R590	5135-391522	RES, CBN 1/2P 390

**MISCELLANEOUS**

953	JL514	4242-R0203101	JUMPER LEAD
-----	-------	---------------	-------------

Ser.No	Ref. No.	Part No.	Description
862	SW5A/ B/C/D/E	4431-05127159	SWITCH, PUSH
863	SW7	4431-S1601104	SWITCH, PUSH

**PCB-7 VOLUME P.C. BOARD**

**RESISTORS**

673	R509	5135-472522	RES, CBN 1/2P 4.7K
673	R510	5135-472522	RES, CBN 1/2P 4.7K

**CONTROLS**

877	VR503/ 504	5113-10472147	RES, V CBN 16 100K
-----	---------------	---------------	--------------------

**MISCELLANEOUS**

912	CN514	4443-030185	CONNECTOR
-----	-------	-------------	-----------

**PCB-8 BIAS P.C. BOARD (Lgh)**

**RESISTORS**

752	R801(L)	5135-222522	RES, CBN 1/2P 2.2K
753	R802(L)	5135-122522	RES, CBN 1/2P 1.2K

**TRANSISTOR**

754	Q801(L)	5613-2682(Q)	XISTOR, NPN R
-----	---------	--------------	---------------

**PCB-9 BIAS P.C. BOARD (Rgh)**

**RESISTORS**

752	R801(R)	5135-222522	RES, CBN 1/2P 2.2K
753	R802(R)	5135-122522	RES, CBN 1/2P 1.2K

**TRANSISTOR**

754	Q801(R)	5613-2682(Q)	XISTOR, NPN R
-----	---------	--------------	---------------

**PCB-10 PHONO P.C. BOARD**

**CAPACITORS**

059B	C561	5361-101KB	CAP, CER 100p (G) (GB)
059B	C562	5361-101KB	CAP, CER 100p (G) (GB)
059B	C563	5361-101KB	CAP, CER 100p (G) (GB)
059B	C564	5361-101KB	CAP, CER 100p (G) (GB)
059B	C565	5361-101KB	CAP, CER 100p (G) (GB)
059B	C566	5361-101KB	CAP, CER 100p (G) (GB)
545	C601	5345-106D0951	CAP, MINI ELE 10μ/25V
545	C602	5345-106D0951	CAP, MINI ELE 10μ/25V
555	C603	5353-121534	CAP, MCA 120p
555	C604	5353-121534	CAP, MCA 120p
554	C605	5359-1015851	CAP, PPP 100p
554	C606	5359-1015851	CAP, PPP 100p
546	C607	5345-477B0952	CAP, MINI ELE 470μ/10V
546	C608	5345-477B0952	CAP, MINI ELE 470μ/10V
548	C609	5345-226C041	CAP, MINI ELE 22μ/16V
548	C610	5345-226C041	CAP, MINI ELE 22μ/16V
551	C611	5359-1825851	CAP, PPP 1800p
551	C612	5359-1825851	CAP, PPP 1800p
552	C613	5359-5625851	CAP, PPP 5600p
552	C614	5359-5625851	CAP, PPP 5600p
550	C615	5359-1215851	CAP, PPP 120p
550	C616	5359-1215851	CAP, PPP 120p
556	C619	5354-102J1HM	CAP, MYL 1000p
556	C620	5354-102J1HM	CAP, MYL 1000p
547	C623	5345-106F0951	CAP, MINI ELE 10μ/50V
547	C624	5345-106F0951	CAP, MINI ELE 10μ/50V
686	C625	5345-337G0962	CAP, MINI ELE 330μ/63V
686	C626	5345-337G0962	CAP, MINI ELE 330μ/63V
686	C627	5345-337G0962	CAP, MINI ELE 330μ/63V
686	C628	5345-337G0962	CAP, MINI ELE 330μ/63V
053B	C681	5353-330534	CAP, MCA 33p (G) (GB)
053B	C682	5353-330534	CAP, MCA 33p (G) (GB)

Ser.No	Ref. No.	Part No.	Description
052B	C683	5354-473593	CAP, MYL .047μ (G) (GB)
052B	C684	5354-473593	CAP, MYL .047μ (G) (GB)
051B	C685	5359-6815851	CAP, PPP 680p (G) (GB)
051B	C686	5359-6815851	CAP, PPP 680p (G) (GB)
058B	C687	5361-223ZF	CAP, CER .022μ (G) (GB)
512	C703	5345-106F0951	CAP, MINI ELE 10μ/50V
512	C704	5345-106F0951	CAP, MINI ELE 10μ/50V
512	C705	5345-106F0951	CAP, MINI ELE 10μ/50V
512	C706	5345-106F0951	CAP, MINI ELE 10μ/50V
511	C707	5345-337C041	CAP, MINI ELE 330μ/16V
511	C708	5345-337C041	CAP, MINI ELE 330μ/16V
511	C709	5345-337C041	CAP, MINI ELE 330μ/16V
511	C710	5345-337C041	CAP, MINI ELE 330μ/16V
587	C808	5354-102J1HM	CAP, MYL 1000p

**RESISTORS**

061B	R565	5232-102J16P	RES, CBN 1/6P 1K (G) (GB)
061B	R566	5232-102J16P	RES, CBN 1/6P 1K (G) (GB)
061B	R567	5232-102J16P	RES, CBN 1/6P 1K (G) (GB)
061B	R568	5232-102J16P	RES, CBN 1/6P 1K (G) (GB)
061B	R569	5232-102J16P	RES, CBN 1/6P 1K (G) (GB)
061B	R570	5232-102J16P	RES, CBN 1/6P 1K (G) (GB)
567	R601	5135-470522	RES, CBN 1/2P 47
567	R602	5135-470522	RES, CBN 1/2P 47
580	R603	5135-823522	RES, CBN 1/2P 82K
580	R604	5135-823522	RES, CBN 1/2P 82K
568	R605	5135-124522	RES, CBN 1/2P 120K
568	R606	5135-124522	RES, CBN 1/2P 120K
569	R607	5135-473522	RES, CBN 1/2P 47K
569	R608	5135-473522	RES, CBN 1/2P 47K
570	R609	5135-332522	RES, CBN 1/2P 3.3K
570	R610	5135-332522	RES, CBN 1/2P 3.3K
570	R611	5135-332522	RES, CBN 1/2P 3.3K
570	R612	5135-332522	RES, CBN 1/2P 3.3K
581	R613	5135-331522	RES, CBN 1/2P 330
581	R614	5135-331522	RES, CBN 1/2P 330
581	R615	5135-331522	RES, CBN 1/2P 330
581	R616	5135-331522	RES, CBN 1/2P 330
581	R617	5135-331522	RES, CBN 1/2P 330
581	R618	5135-331522	RES, CBN 1/2P 330
581	R619	5135-331522	RES, CBN 1/2P 330
581	R620	5135-331522	RES, CBN 1/2P 330
561	R621	5174-751381	RES, MTL 1/4P 750
561	R622	5174-751381	RES, MTL 1/4P 750
571	R623	5135-222522	RES, CBN 1/2P 2.2K
571	R624	5135-222522	RES, CBN 1/2P 2.2K
571	R625	5135-222522	RES, CBN 1/2P 2.2K
571	R626	5135-222522	RES, CBN 1/2P 2.2K
565	R627	5174-102381	RES, MTL 1/4P 1K
565	R628	5174-102381	RES, MTL 1/4P 1K
572	R629	5135-682522	RES, CBN 1/2P 6.8K
572	R630	5135-682522	RES, CBN 1/2P 6.8K
572	R631	5135-682522	RES, CBN 1/2P 6.8K
572	R632	5135-682522	RES, CBN 1/2P 6.8K
573	R633	5135-471522	RES, CBN 1/2P 470
573	R634	5135-471522	RES, CBN 1/2P 470
573	R635	5135-471522	RES, CBN 1/2P 470
573	R636	5135-471522	RES, CBN 1/2P 470
576	R637	5135-330522	RES, CBN 1/2P 33
576	R638	5135-330522	RES, CBN 1/2P 33
576	R639	5135-330522	RES, CBN 1/2P 33
576	R640	5135-330522	RES, CBN 1/2P 33
574	R641	5174-Z412238	RES, MTL 1/4P 41.2K
574	R642	5174-Z412238	RES, MTL 1/4P 41.2K
564	R645	5174-135381	RES, MTL 1/4P 1.3M
564	R646	5174-135381	RES, MTL 1/4P 1.3M
563	R647	5174-145381	RES, MTL 1/4P 1.4M
563	R648	5174-145381	RES, MTL 1/4P 1.4M
577	R649	5135-102522	RES, CBN 1/2P 1K
577	R650	5135-102522	RES, CBN 1/2P 1K
579	R651	5135-104522	RES, CBN 1/2P 100K
579	R652	5135-104522	RES, CBN 1/2P 100K

Ser.No	Ref. No.	Part No.	Description
689	R653	5135-822522	RES, CBN 1/2P 8.2K
689	R654	5135-822522	RES, CBN 1/2P 8.2K
687	△ R655	5102-2205116	RES, FUSE 22
687	△ R656	5102-2205116	RES, FUSE 22
690	R657	5135-220522	RES, CBN 1/2P 22
690	R658	5135-220522	RES, CBN 1/2P 22
562	R661	5135-474522	RES, CBN 1/2P 470K
562	R662	5135-474522	RES, CBN 1/2P 470K
690	R667	5135-220522	RES, CBN 1/2P 22
690	R668	5135-220522	RES, CBN 1/2P 22
055B	R681	5135-102522	RES, CBN 1/2P 1K <b>G GB</b>
055B	R682	5135-102522	RES, CBN 1/2P 1K <b>G GB</b>
055B	R683	5135-102522	RES, CBN 1/2P 1K <b>G GB</b>
055B	R684	5135-102522	RES, CBN 1/2P 1K <b>G GB</b>
516	R701	5135-1R0522	RES, CBN 1/2P 1 <b>BK I IB</b>
516B	R701	5135-5R6522	RES, CBN 1/2P 5.6 <b>G GB</b>
516	R702	5135-1R0522	RES, CBN 1/2P 1 <b>BK I IB</b>
516B	R702	5135-5R6522	RES, CBN 1/2P 5.6 <b>G GB</b>
519	R703	5135-560522	RES, CBN 1/2P 56
519	R704	5135-560522	RES, CBN 1/2P 56
521	R705	5135-472522	RES, CBN 1/2P 4.7K
521	R706	5135-472522	RES, CBN 1/2P 4.7K
521	R707	5135-472522	RES, CBN 1/2P 4.7K
521	R708	5135-472522	RES, CBN 1/2P 4.7K
517	R709	5135-100522	RES, CBN 1/2P 10
517	R710	5135-100522	RES, CBN 1/2P 10
517	R711	5135-100522	RES, CBN 1/2P 10
517	R712	5135-100522	RES, CBN 1/2P 10
518	R713	5135-220522	RES, CBN 1/2P 22
518	R714	5135-220522	RES, CBN 1/2P 22
518	R715	5135-220522	RES, CBN 1/2P 22
518	R716	5135-220522	RES, CBN 1/2P 22
515	R717	5174-561381	RES, MTL 1/4P 560
515	R718	5174-561381	RES, MTL 1/4P 560
515	R719	5174-561381	RES, MTL 1/4P 560
515	R720	5174-561381	RES, MTL 1/4P 560
520	R721	5135-392522	RES, CBN 1/2P 3.9K
520	R722	5135-392522	RES, CBN 1/2P 3.9K
522	R723	5135-681522	RES, CBN 1/2P 680
522	R724	5135-681522	RES, CBN 1/2P 680
523	R727	5135-331522	RES, CBN 1/2P 330
523	R728	5135-331522	RES, CBN 1/2P 330
588	R816	5135-104522	RES, CBN 1/2P 100K
588	R817	5135-104522	RES, CBN 1/2P 100K
589	R818	5135-103522	RES, CBN 1/2P 10K
590	R819	5135-105522	RES, CBN 1/2P 1M

#### TRANSISTORS

531	Q601	5613-2240(BL)	XISTOR, NPN R
531	Q602	5613-2240(BL)	XISTOR, NPN R
531	Q603	5613-2240(BL)	XISTOR, NPN R
531	Q604	5613-2240(BL)	XISTOR, NPN R
532	Q605	5613-2320(LF)	XISTOR, NPN R
532	Q606	5613-2320(LF)	XISTOR, NPN R
532	Q607	5613-2320(LF)	XISTOR, NPN R
532	Q608	5613-2320(LF)	XISTOR, NPN R
533	Q609	5611-999L(F)	XISTOR, PNP R
533	Q610	5611-999L(F)	XISTOR, PNP R
538	Q611	5613-2320(LF)	XISTOR, NPN R
538	Q612	5613-2320(LF)	XISTOR, NPN R
533	Q613	5611-999L(F)	XISTOR, PNP R
533	Q614	5611-999L(F)	XISTOR, PNP R
535	Q615	5612-646(C)	XISTOR, PNP A
535	Q616	5612-646(C)	XISTOR, PNP A
534	Q617	5614-666(C)	XISTOR, NPN A
534	Q618	5614-666(C)	XISTOR, NPN A
536	Q619	5614-667(C)	XISTOR, NPN A
536	Q620	5614-667(C)	XISTOR, NPN A
537	Q621	5612-647(C)	XISTOR, PNP A
537	Q622	5612-647(C)	XISTOR, PNP A
681	Q623	5613-3298(Y)	XISTOR, NPN R
683	Q624	5611-1306(Y)	XISTOR, PNP R

Ser.No	Ref. No.	Part No.	Description
502	Q701	5611-1190(E)	XISTOR, PNP R
502	Q702	5611-1190(E)	XISTOR, PNP R
501	Q703	5613-2855(D)	XISTOR, NPN R
501	Q704	5613-2855(D)	XISTOR, NPN R
501	Q705	5613-2855(D)	XISTOR, NPN R
501	Q706	5613-2855(D)	XISTOR, NPN R
502	Q707	5611-1190(E)	XISTOR, PNP R
502	Q708	5611-1190(E)	XISTOR, PNP R
503	Q709	5613-1740S(S)	XISTOR, NPN R
504	Q710	5611-933S(S)	XISTOR, PNP R
504	Q711	5611-933S(S)	XISTOR, PNP R
503	Q712	5613-1740S(S)	XISTOR, NPN R
505	Q713	5616-2SK373GR	FET, N-CH
505	Q714	5616-2SK373GR	FET, N-CH
585	Q803	5611-933S(S)	XISTOR, PNP R
585	Q804	5611-933S(S)	XISTOR, PNP R
586	Q805	5616-2SK364(V)	FET, N-CH
586	Q806	5616-2SK364(V)	FET, N-CH

#### DIODES

541	D601	5631-1S2473	DIODE, DET
541	D602	5631-1S2473	DIODE, DET
542	D603	5641-KB362	VARIATOR
542	D604	5641-KB362	VARIATOR
685	D605	5635-HZ24-2L	DIODE, ZENER
685	D606	5635-HZ24-2L	DIODE, ZENER
508	D701	5635-HZ15-1L	DIODE, ZENER
508	D702	5635-HZ15-1L	DIODE, ZENER

#### COILS

056B	L701	5597-3	CORE, BEADS <b>G GB</b>
056B	L702	5597-3	CORE, BEADS <b>G GB</b>

#### MISCELLANEOUS

914	CN304	4443-070185	CONNECTOR
911	CN402	4443-030185	CONNECTOR
911	CN501	4443-030185	CONNECTOR
911	CN507	4443-030185	CONNECTOR
892	△ J4	4484-31	PIN JACK, 4P
893	△ J5	4486-9	PIN JACK, 6P
583	LCN517	4163-0125039	CONNECTOR W/W
525	LCN701	4163-0125039	CONNECTOR W/W
865	SW9	4422-70211	SWITCH, REMOTE

#### PCB-11 PIN JACK P.C. BOARD

#### CAPACITORS

060B	C567	5361-101KB	CAP, CER 100p <b>G GB</b>
060B	C568	5361-101KB	CAP, CER 100p <b>G GB</b>
060B	C569	5361-101KB	CAP, CER 100p <b>G GB</b>
060B	C570	5361-101KB	CAP, CER 100p <b>G GB</b>
060B	C571	5361-101KB	CAP, CER 100p <b>G GB</b>
060B	C572	5361-101KB	CAP, CER 100p <b>G GB</b>
060B	C573	5361-101KB	CAP, CER 100p <b>G GB</b>
060B	C574	5361-101KB	CAP, CER 100p <b>G GB</b>
060B	C575	5361-101KB	CAP, CER 100p <b>G GB</b>
060B	C576	5361-101KB	CAP, CER 100p <b>G GB</b>

#### RESISTORS

063B	R571	5232-102J16P	RES, CBN 1/6P 1K <b>G GB</b>
063B	R572	5232-102J16P	RES, CBN 1/6P 1K <b>G GB</b>
063B	R573	5232-102J16P	RES, CBN 1/6P 1K <b>G GB</b>
063B	R574	5232-102J16P	RES, CBN 1/6P 1K <b>G GB</b>
063B	R575	5232-102J16P	RES, CBN 1/6P 1K <b>G GB</b>
063B	R576	5232-102J16P	RES, CBN 1/6P 1K <b>G GB</b>
063B	R577	5232-102J16P	RES, CBN 1/6P 1K <b>G GB</b>
063B	R578	5232-102J16P	RES, CBN 1/6P 1K <b>G GB</b>
063B	R579	5232-102J16P	RES, CBN 1/6P 1K <b>G GB</b>
063B	R580	5232-102J16P	RES, CBN 1/6P 1K <b>G GB</b>
619	R585	5135-102522	RES, CBN 1/2P 1K
619	R586	5135-102522	RES, CBN 1/2P 1K
618	R587	5135-471522	RES, CBN 1/2P 470

Ser.No	Ref. No.	Part No.	Description
618	R588	5135-471522	RES, CBN 1/2P 470

**MISCELLANEOUS**

891	△ J2	4484-47	PIN JACK, 4P
891	△ J3	4484-47	PIN JACK, 4P
894	△ J6	4486-16	PIN JACK, 6P
679	LCN519	4163-0130039	CONNECTOR WW
680	LCN529	4163-0130039	CONNECTOR WW

**PCB-12 LED P.C. BOARD**

**CAPACITOR**

903	C78	5345-106C0951	CAP, MINI ELE 10μ/16V
-----	-----	---------------	-----------------------

**DIODE**

905	D78	5637-GL5EG41	LED
-----	-----	--------------	-----

**MISCELLANEOUS**

955	JL804	4242-R0203101	JUMPER LEAD
-----	-------	---------------	-------------

**CHASSIS MISCELLANEOUS**

**MISCELLANEOUS**

044B	△ CO1	4443-712	CONNECTOR <b>G GB I IB</b>
836	△ F1	5732-632029	FUSE <b>BK</b>
836E	△ F1	5732-312030	FUSE <b>G GB I IB</b>
837	△ F2	5732-502029	FUSE <b>BK</b>
837	△ F3	5732-502029	FUSE <b>BK</b>
837	△ F4	5732-502029	FUSE <b>BK</b>
837	△ F5	5732-502029	FUSE <b>BK</b>
065B	LUG1	4211-4	LUG <b>G GB</b>
900	△ P1	4161-71151	CORD W/PLUG <b>BK</b>
900B	△ P1	4161-7256	CORD W/PLUG <b>G GB I IB</b>
896	△ SO1	4474-156	SOCKET <b>BK</b>
041B	△ SW101	4411-102729	SWITCH, ROTARY <b>G GB I IB</b>
866	△ SW102	4464-00101012	SWITCH, SEESAW <b>BK</b>
866B	△ SW102	4464-00101022	SWITCH, SEESAW <b>G GB I IB</b>
831	△ T1	5584-S2511	XFORMER, POWER <b>BK</b>
831B	△ T1	5584-S2512	XFORMER, POWER <b>G GB I IB</b>
043B		4150-8	TUBING, SPE <b>G GB I IB</b>
902		4442-14	PIN PLUG

Ser.No	Ref. No.	Part No.	Description
--------	----------	----------	-------------

**PACKAGE PARTS LIST**

021		1756-06303	LABEL <b>G GB I IB</b>
022		1756-03124	LABEL <b>G GB</b>
022		1756-03108	LABEL <b>I IB</b>
028		1119-0135	ATTACH SHEET <b>G GB</b>
028		1756-09501	LABEL <b>BB</b>
030		1756-09501	LABEL, CARTON <b>IB</b>
106		1119-01201	ATTACH SHEET <b>BK</b>
107		1111-J30315	OWNER GUIDE <b>BK</b>
107		1111-J30316	OWNER GUIDE <b>G GB I IB</b>
108		1113-717004	OWNER CARD <b>BK</b>
109		1119-047	ATTACH SHEET <b>BK</b>
110		1119-0137	ATTACH SHEET <b>BK</b>
121		1241-C12732	POLYETHYLENE BAG
122		1241-C1492	POLYETHYLENE BAG
124		1221-847143	CARTON BOX <b>G I</b>
124		1221-857143	CARTON BOX <b>GB BB IB BK</b>
125		1222-7225	CUSHION, R
126		1222-7226	CUSHION, L
127		1223-11729	SOFT SHEET

**ABBREVIATIONS IN PARTS LIST**

**CAPACITORS**

CAP, MINI ELE	: Electrolytic
CAP, CER	: Ceramic
CAP, PPP	: Polypropylene
CAP, MYL	: Mylar
CAP, MCA	: Mica
CAP, MINI BP	: Bipolar
CAP, ELE BP	: Electrolytic Bipolar
CAP, STY	: Polystyrene Film
CAP, SPE	: Special
CAP, TAN	: Tantalum
470μ	: 470μF
6800p	: 6800pF
.047μ	: 0.047μF

**RESISTORS**

RES, CBN 1/6P	: Carbon 1/6W
RES, FUZE	: Fuse
RES, CEM 5P	: Cement 5W
RES, MTL 1P	: Metal 1W
2.2K	: 2.2KΩ
220	: 220Ω

**TRANSISTORS**

XISTOR	: Transistor
FET	: Field Effect Transistor

**CONTROLS**

RES, V CBN	: Variable Carbon Resistor
RES, SEMI FIX	: Semi-fixed Resistor

**NOTE**



SAFETY RELATED COMPONENT. USE ONLY EXACT REPLACEMENT PART AS SPECIFIED.

# SCHEMATIC DIAGRAM (PHONO AMP SECTION)

PCB-10

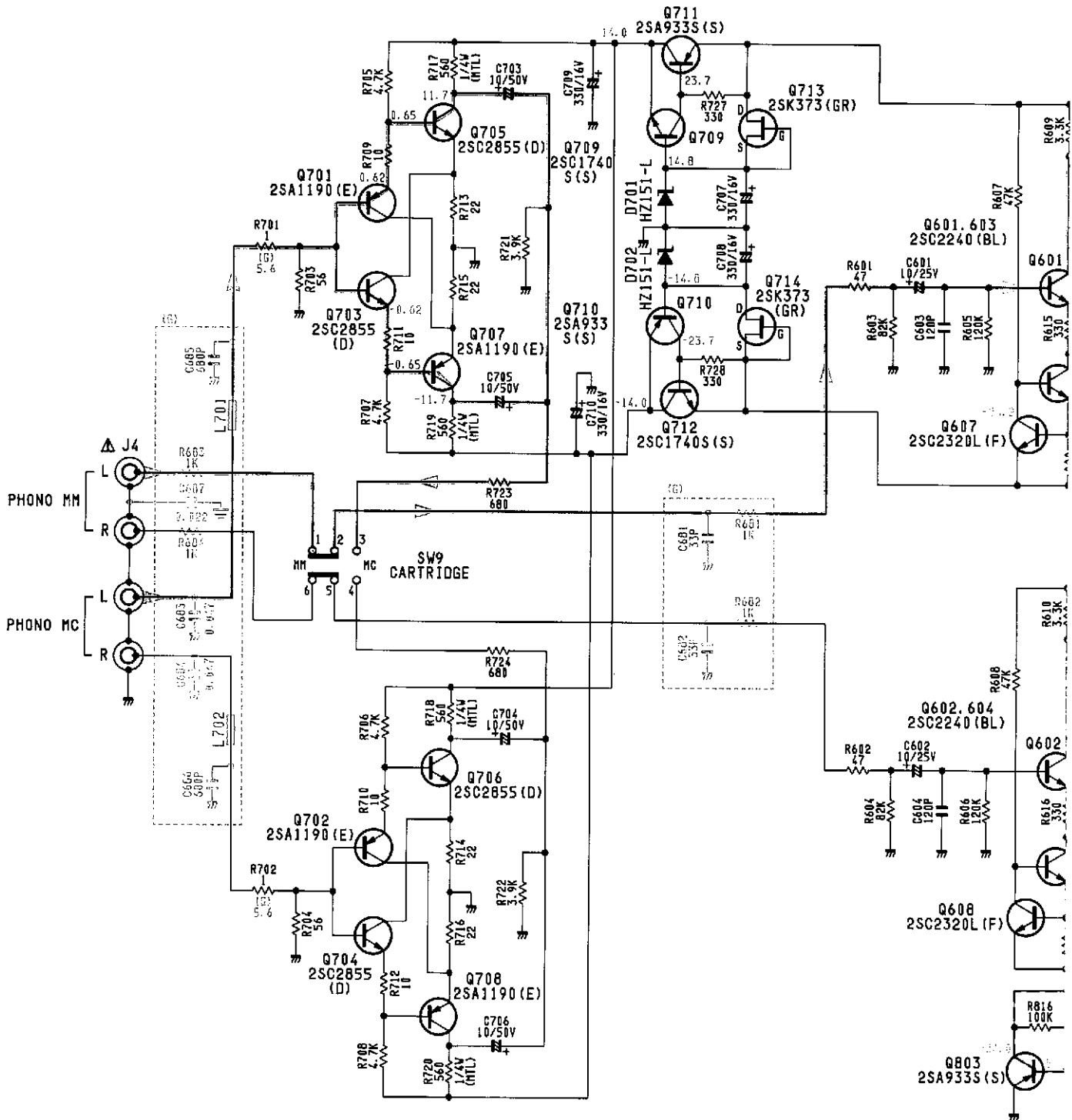

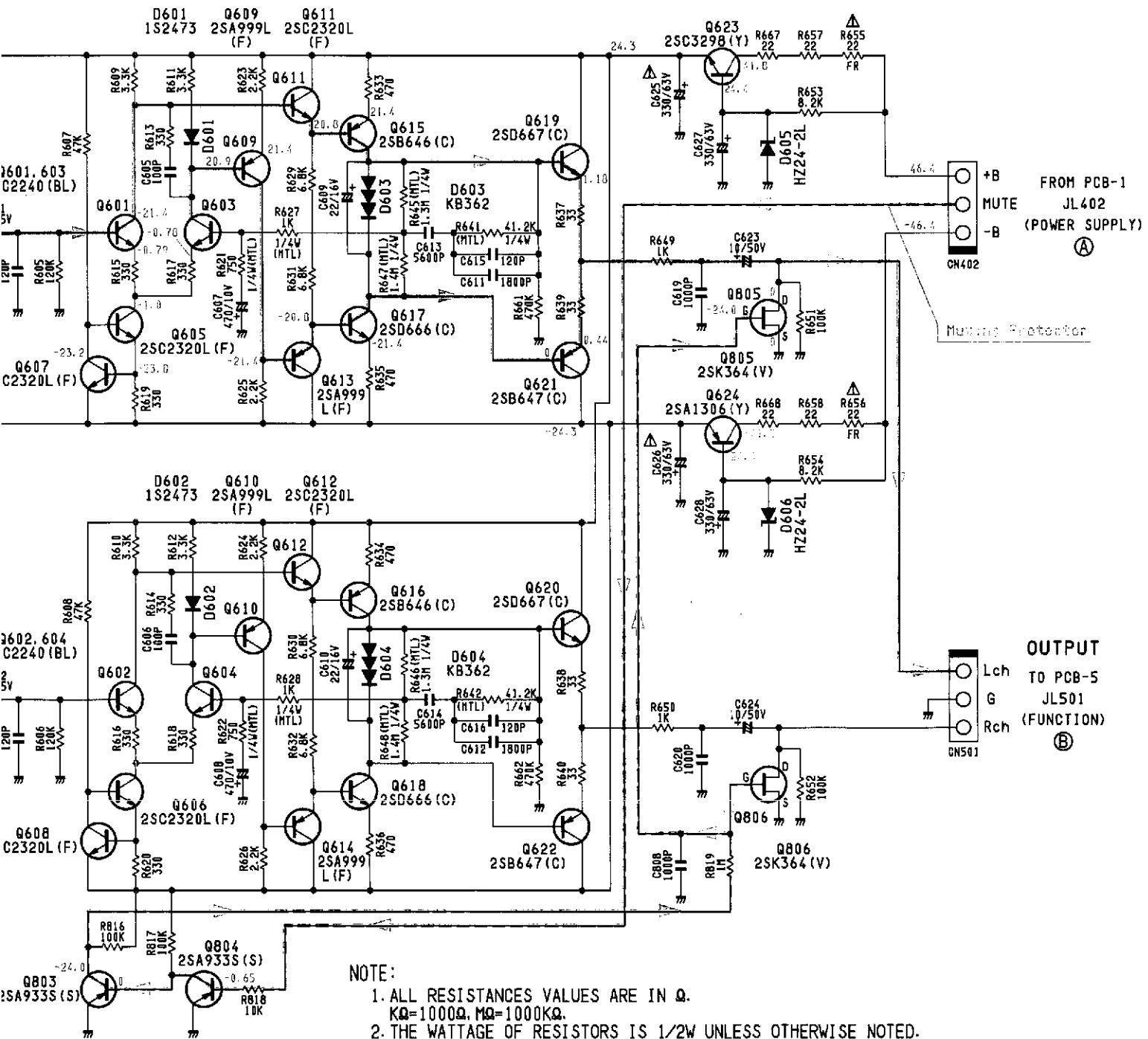

NOTE:

1. ALL RESISTANCES VALUES ARE IN  $\Omega$ .  
K $\Omega$ =1000 $\Omega$ , M $\Omega$ =1000K $\Omega$ .
2. THE WATTAGE OF RESISTORS IS 1/2W UNLESS OTHERWISE NOTED.
3. ALL CAPACITANCES VALUES ARE IN  $\mu$ F UNLESS OTHERWISE NOTED. P= $\mu$ F.
4. SAFETY REQUIREMENTS COMPONENTS IN ACCORDANCE WITH PRESENT SAFETY REGULATIONS. THESE COMPONENTS MUST ONLY BE REPLACED BY ORIGINAL PARTS.



SCHEMATIC DIAGRAM (FUNCTION & TONE CONTROL SECTION)

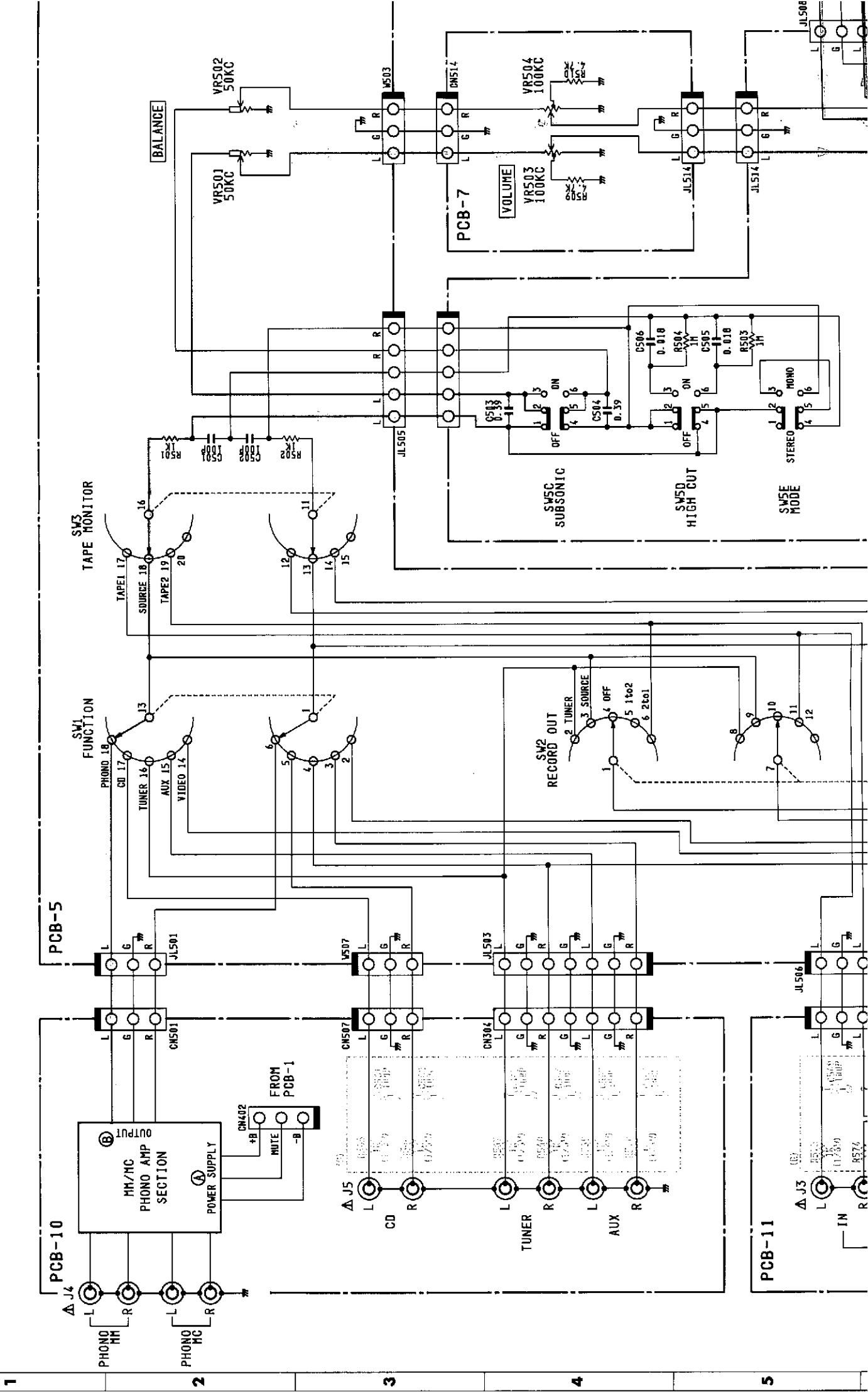

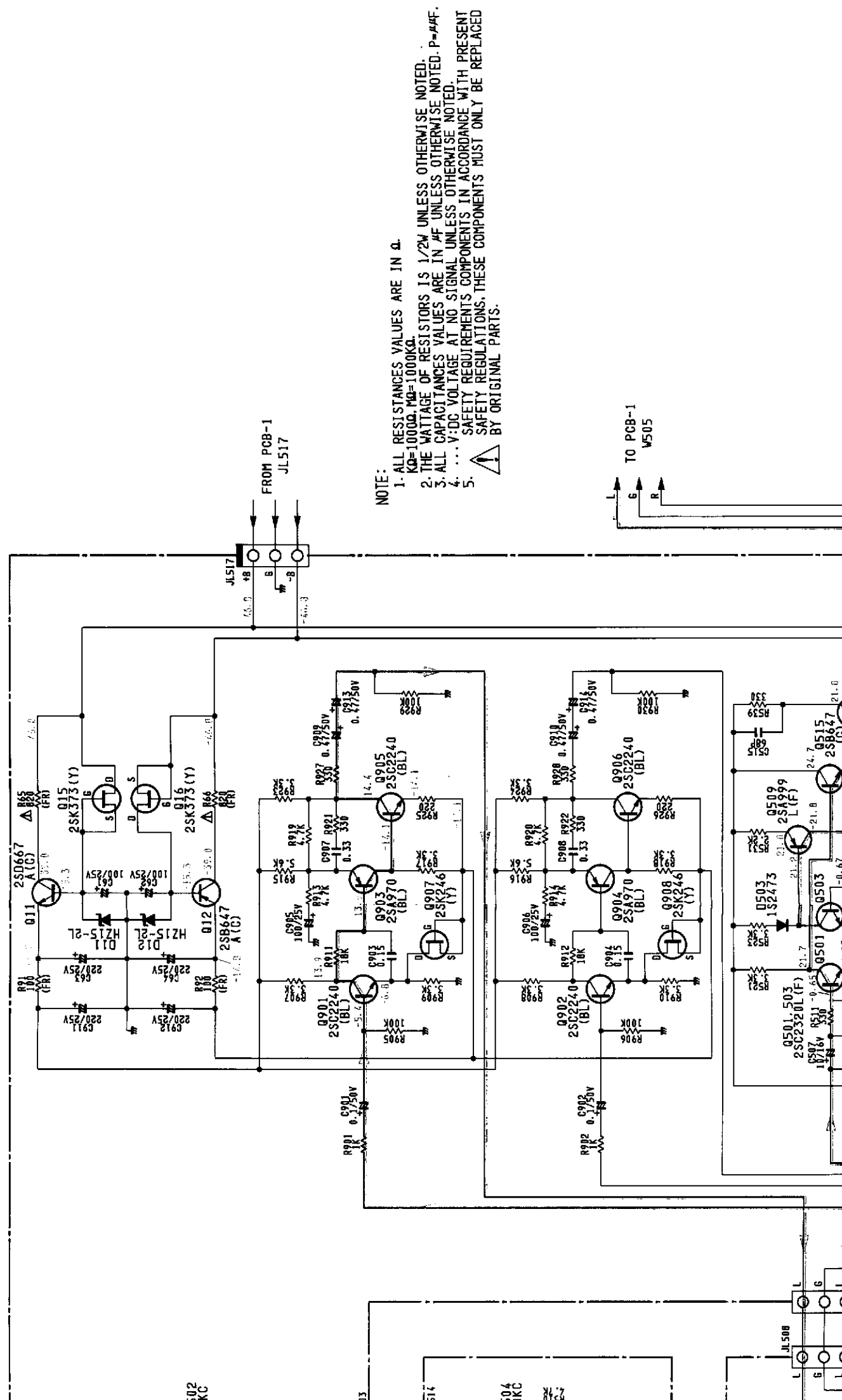

NOTE:

1. ALL RESISTANCES VALUES ARE IN  $\Omega$ .
2. THE WATTAGE OF RESISTORS IS 1/2W UNLESS OTHERWISE NOTED.
3. ALL CAPACITANCES VALUES ARE IN  $\mu$ F UNLESS OTHERWISE NOTED.
4. ... V:DC VOLTAGE AT NO SIGNAL UNLESS OTHERWISE NOTED.
5. SAFETY REGULATIONS COMPONENTS IN ACCORDANCE WITH PRESENT REGULATIONS, THESE COMPONENTS MUST ONLY BE REPLACED BY ORIGINAL PARTS.

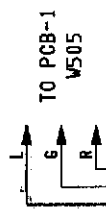

502 JKC

503

504 OKC

JL508



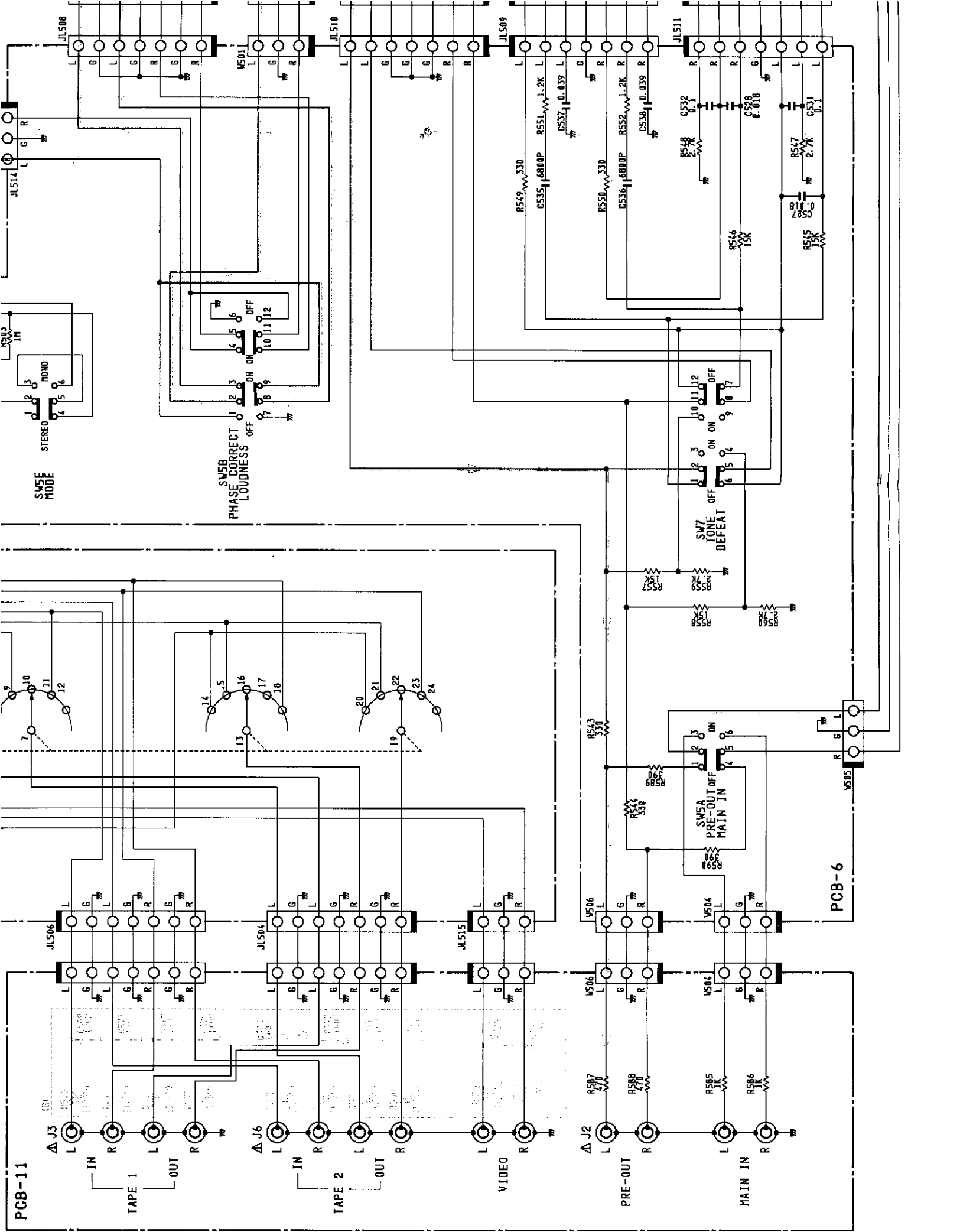



A B C D E F G

SCHEMATIC DIAGRAM (POWER AMP SECTION)

1

2

3

4

5

PCB-1

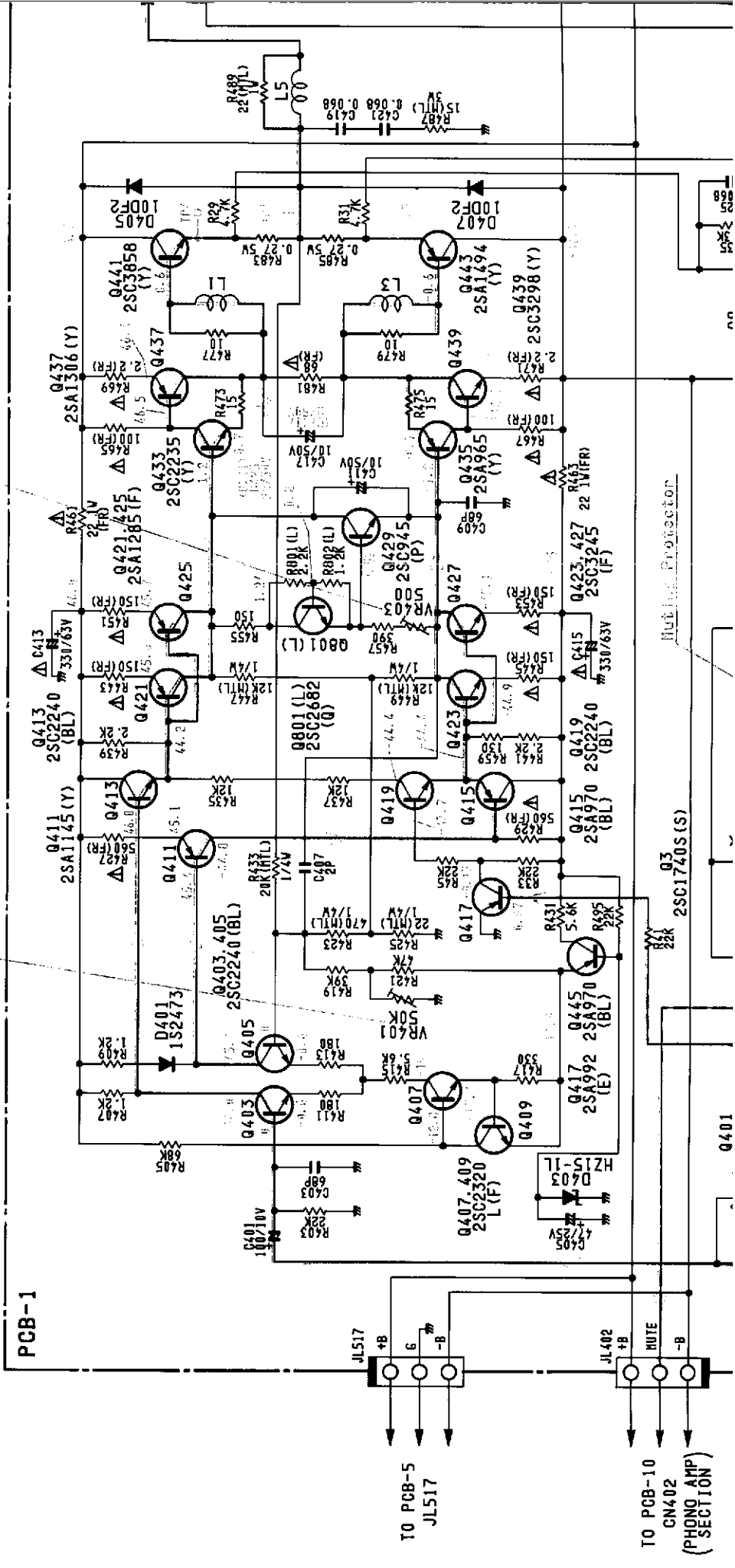

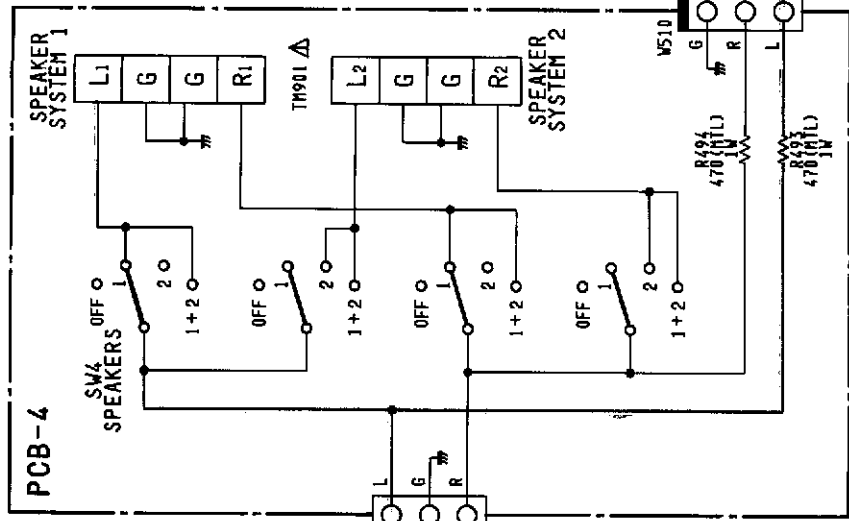

NOTE:

- 1- ALL RESISTANCE VALUES ARE IN  $\Omega$ .  
K $\Omega$ =1000 $\Omega$ , M $\Omega$ =1000K $\Omega$ .
2. THE WATTAGE OF RESISTORS IS 1/2W UNLESS OTHERWISE NOTED.
3. ALL CAPACITANCE VALUES ARE IN  $\mu$ F UNLESS OTHERWISE NOTED. P=# $\mu$ F.
4. ... V: DC VOLTAGE AT NO SIGNAL UNLESS OTHERWISE NOTED.
5. SAFETY REQUIREMENTS COMPONENTS IN ACCORDANCE WITH PRESENT SAFETY REGULATIONS. THESE COMPONENTS MUST ONLY BE REPLACED BY ORIGINAL PARTS.

⚠

650-4899-10-0001  
650-4899-10-0001 Model

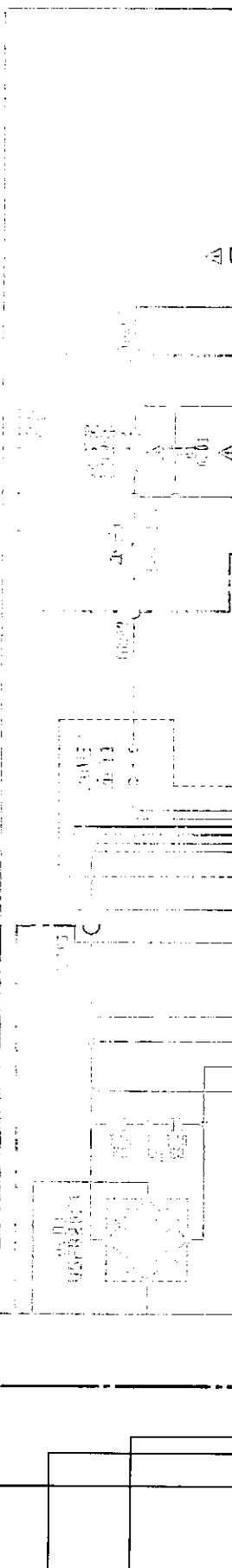

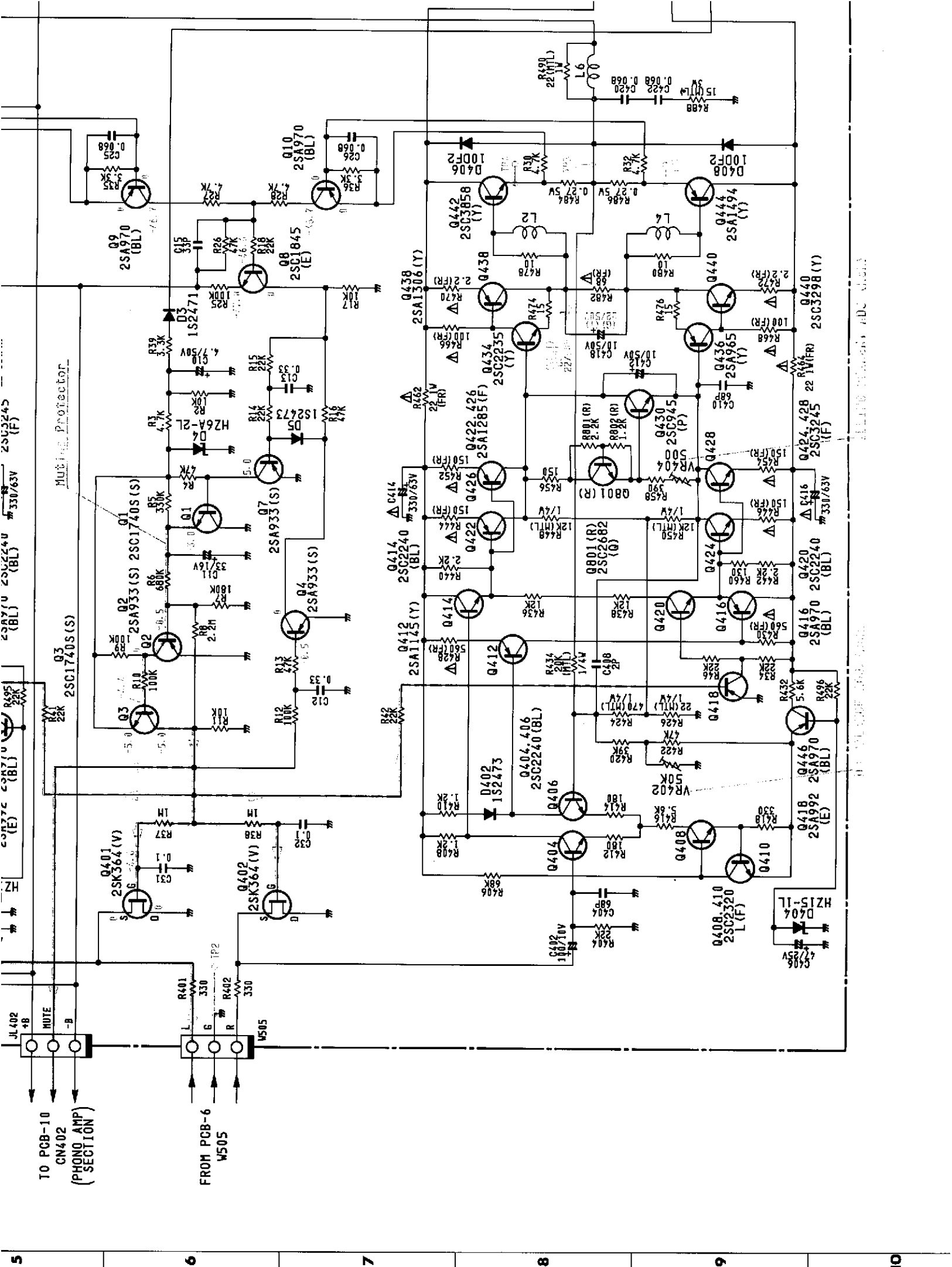

100% REPRODUCED FROM ORIGINAL DRAWING  
 © 1975 SONY ELECTRONICS CORPORATION

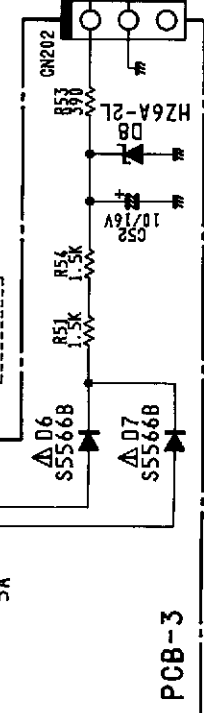
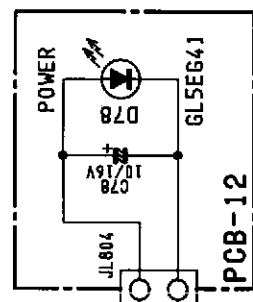
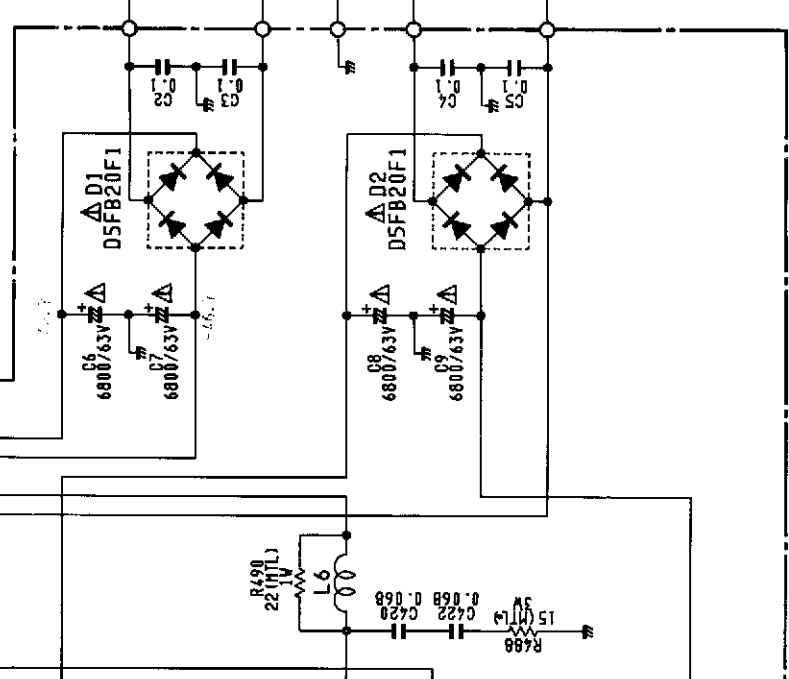
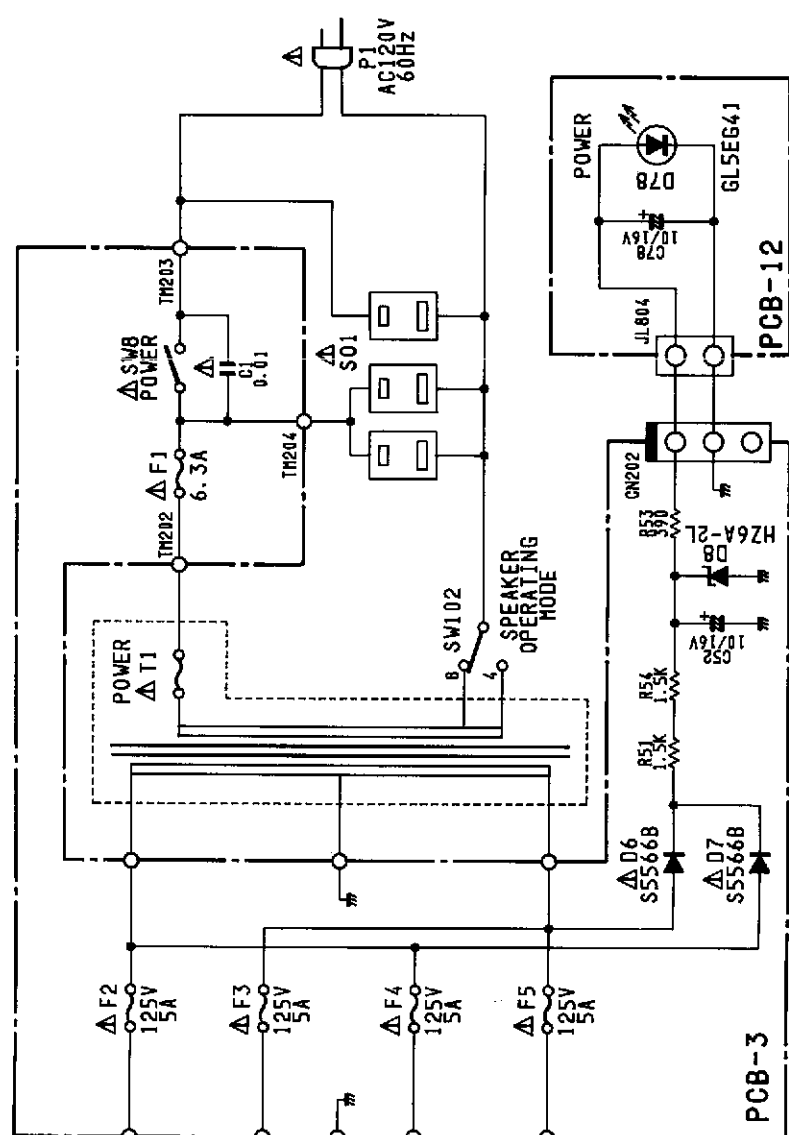
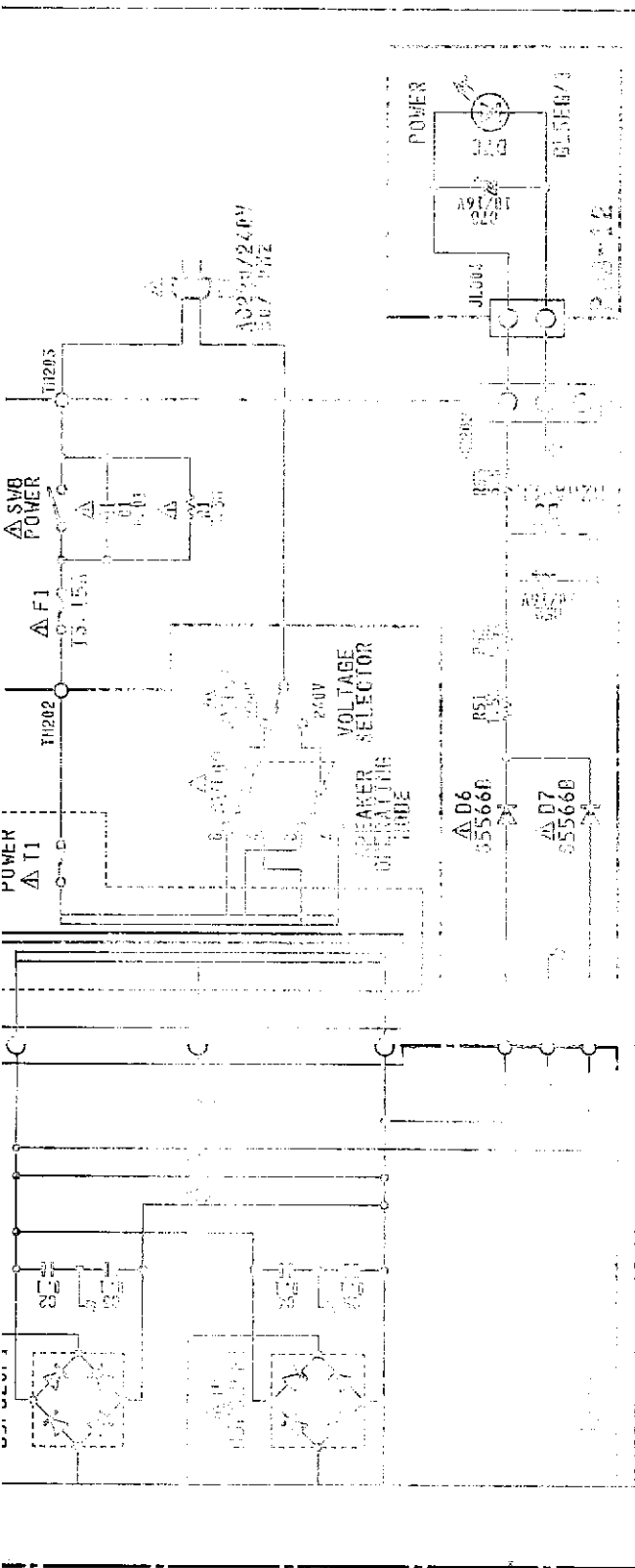

A

B

C

D

E

F

G

# WIRING DIAGRAM

SW102  
SPEAKER  
OPERATING  
MODE

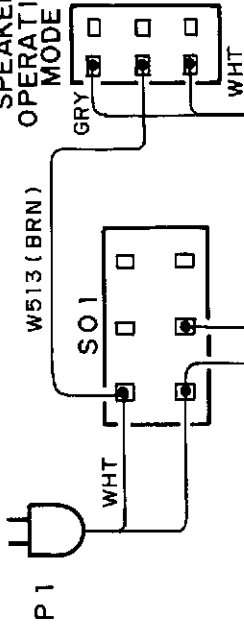

PCB-4

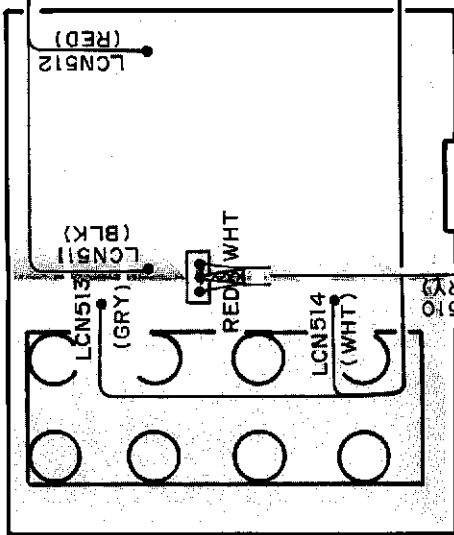

PCB-2

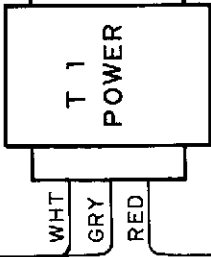
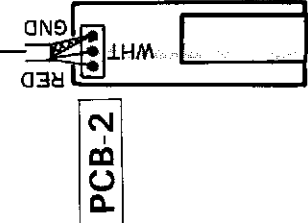

### WIRE COLOR ABBREVIATIONS

- RED : Red
- ORG : Orange
- BLU : Blue
- WHT : White
- GRN : Green
- BLK : Black
- YEL : Yellow
- PUR : Purple
- PIK : Pink
- GRY : Gray
- BRN : Brown

PCB-12

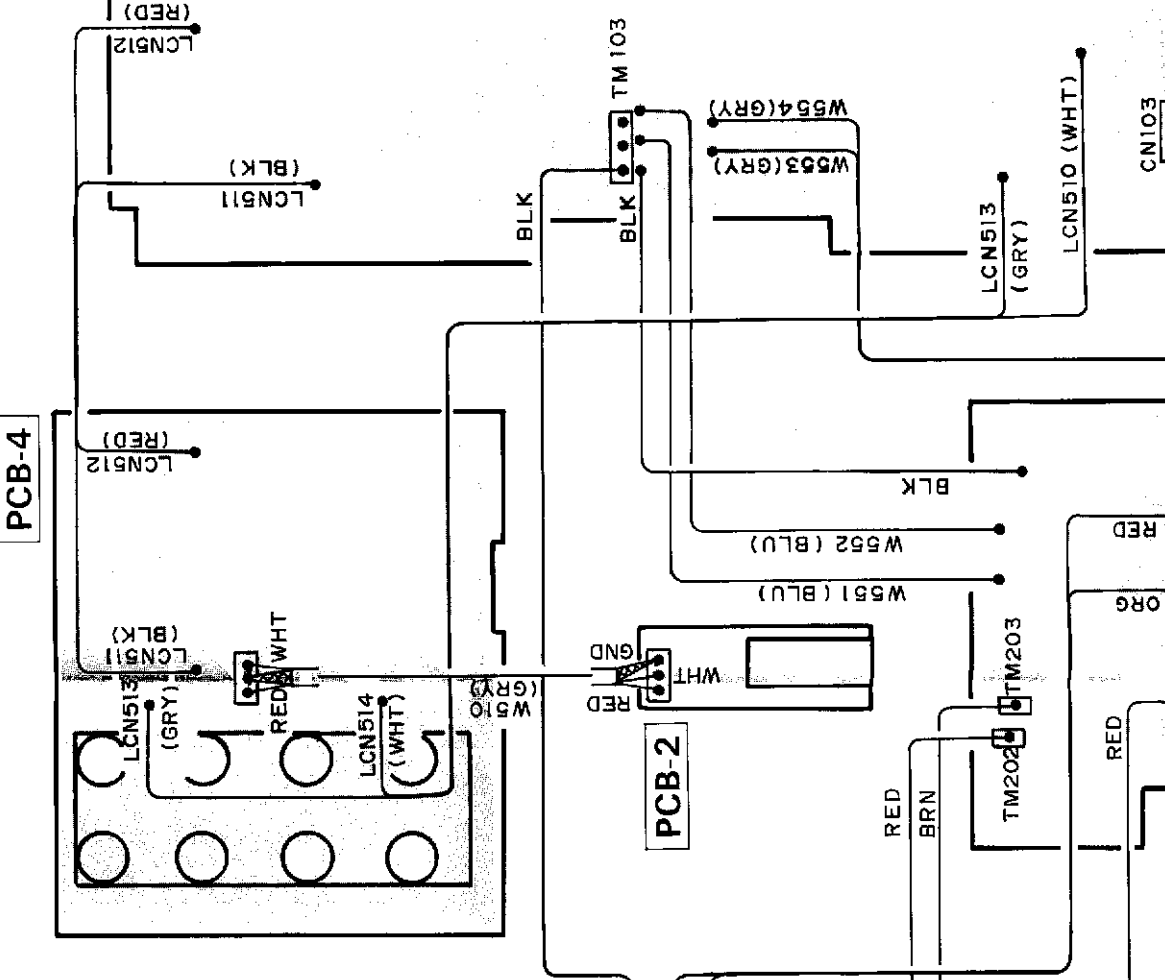
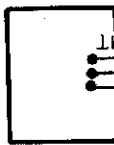

H I J K L M N

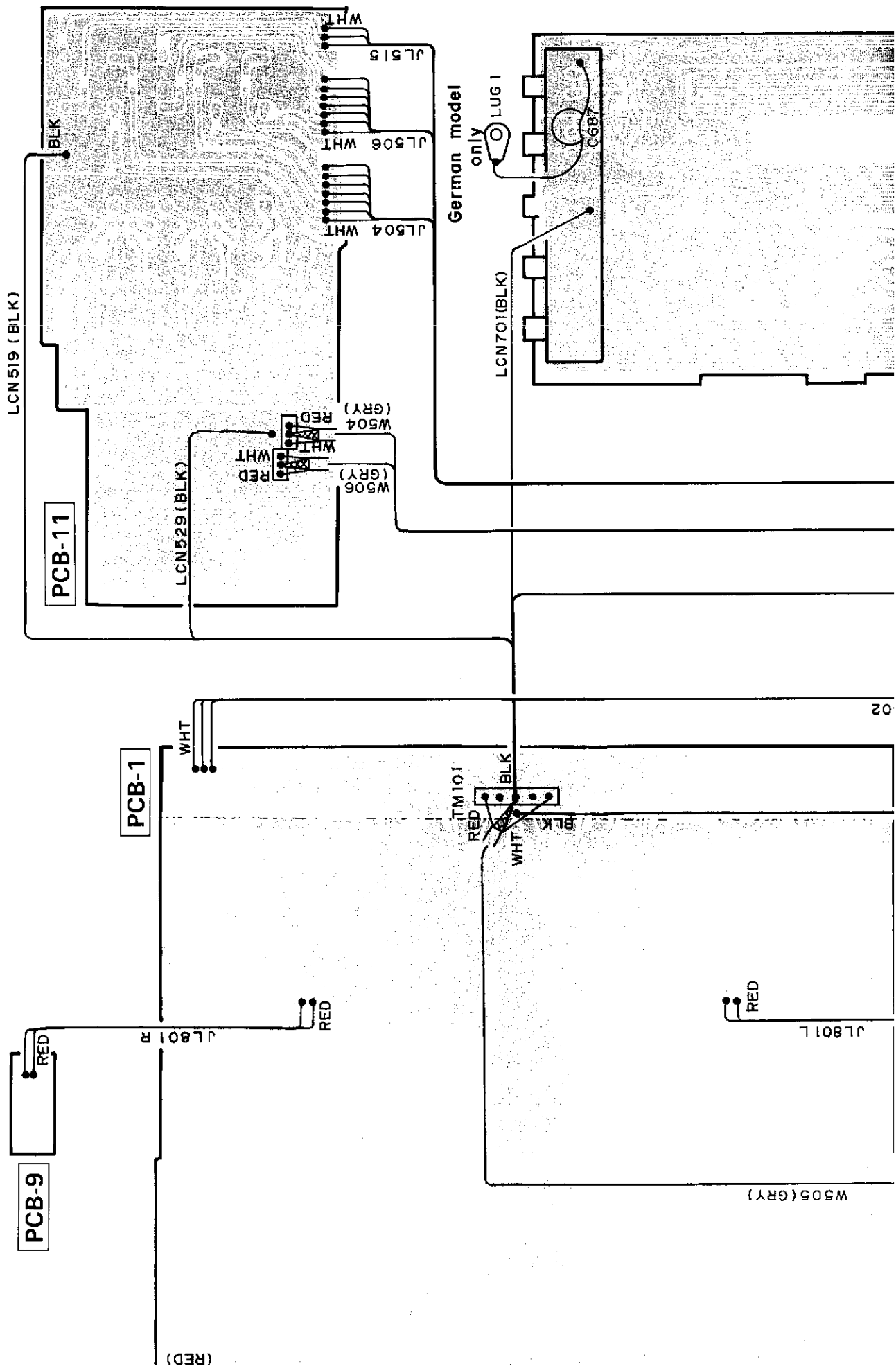

02

(RED)

W505 (GRY)

JL801L

JL801R

TM101

PCB-11

PCB-1

PCB-9

LCN519 (BLK)

LCN529(BLK)

LCN701(BLK)

German model only

LUG 1

C687

JL515 WHT

JL506 WHT

JL504 WHT

W506 (GRY)

W504 (GRY)

WHT

RED

WHT

WHT

RED

BLK

WHT

BLK

RED

RED

RED

RED



