

HK 970 Integrated Amplifier

SERVICE MANUAL

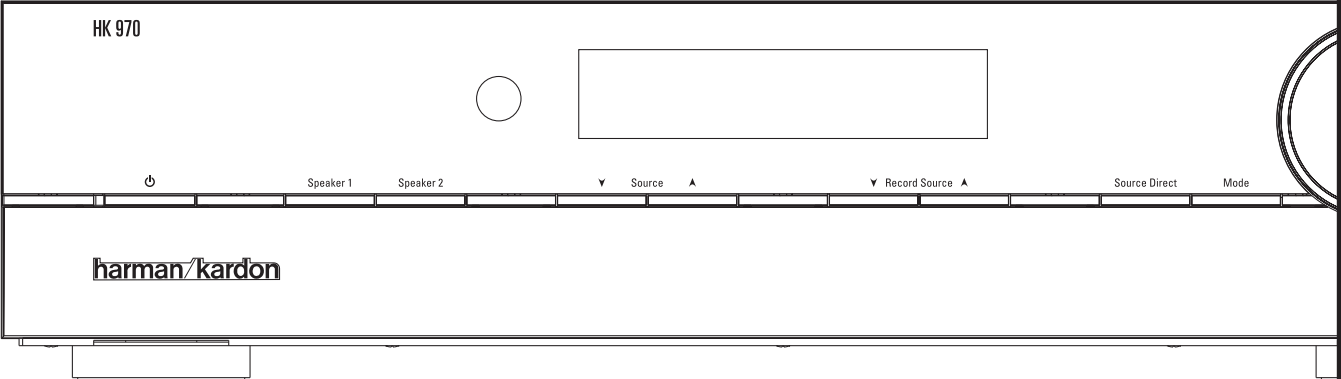

harman/kardon®

Power for the Digital Revolution®

Technical Specifications HK970/230

Audio Section

Stereo Mode	
Continuous Average Power (FTC)	
80 Watts per channel, 20Hz-20kHz	
@ < 0.07% THD, both channels driven into 8 ohms	
100 Watts per channel, 20Hz-20kHz	
@ < 0.2% THD, both channels driven into 4 ohms	
Input Sensitivity/Impedance	
Linear (High Level) 200mV/47kohms	
Signal-to-Noise Ratio (IHF-A)	95dB
Frequency Response	
@ 1W (+0dB, -3dB) 10Hz-110kHz	
High Instantaneous	
Current Capability (HCC)	±42 Amps
Transient Intermodulation	
Distortion (TIM)	Unmeasurable
Rise Time	16 µsec
Slew Rate	40V/µsec

FM Tuner Section

Frequency Range	87.5-108MHz
Usable Sensitivity	IHF: 1.12 µV/13.5dBf
Signal-to-Noise Ratio	Mono/Stereo: 73/72 dBA (DIN)
Distortion	Mono/Stereo: 0.3/0.4%
Stereo Separation	40dB @ 1kHz
Selectivity	±400kHz, 65dB
Image Rejection	>80dB
IF Rejection	>100dB

FM Tuner Section

Frequency Range	520-1710kHz
Signal-to-Noise Ratio	>40dB
Usable Sensitivity	Loop: 500 µV/M
Distortion	1kHz, 50% Mod: 0.8%
Selectivity	±10kHz: > 25dB

Video Section

Television System	NTSC/PAL/SECAM
Signal Format	Composite
Input Level	1Vp-p
Input Impedance	75 ohms, unbalanced
Sync Polarity	Negative
Output Impedance	75 ohms, unbalanced
Video Frequency	
Response	10Hz-10MHz

General

Power Requirement	AC 230V/50Hz
Power Consumption	3W standby, 200W maximum (both channels driven)

Dimension (Max)

Width	439mm
Height	110mm
Depth	395mm
Weight	10.35kg

Depth measurement includes knobs, buttons and terminal connections. Height measurement includes feet and chassis.

All features and specifications are subject to change without notice.

Harman Kardon and Power for the Digital Revolution are registered trademarks of Harman International Industries, Incorporated.

Part List

HK970/230

HK970 PHONE BOARD (9497-015000-021)

Part Number	Reference	Description	Usage
1100-103034-000	C801 C802	CERAMIC CAP. 0.01UF/25V +-20%	2
1102-471014-000	C803 C804	ELECT. CAP. 470uF/16V +-20% 8X12MM	2
1501-080400-000	L801 L802 L803	CHOKO COIL 8UH M6.5X11MM	3
2300-003010-000	CN801	RIGHT ANGLE CONN. WAFER 3 PINS 2mmP	1
2320-009911-000	J801	6.4MM HEADPHONE JACK (JY-6303-02-030)	1
2320-009911-001		6.4MM HEADPHONE JACK W/O NUT (JY-6303-01-030)	1
6600-120120-000		SCREW HEX NUT M12X1.0X2.0MM	1
7112-018006-022		SCREW WASHER M12X18X0.6MM	1
4897-150020-001		HK970 HEADPHONE BOARD REV B	1

HK970 POWER ON/OFF BOARD (9497-015000-171)

Part Number	Reference	Description	Usage
1004-707316-000	R101	CARBON FILM RESISTOR 4.7 OHM 1/6W +-5%	1
2400-020200-006	SW101	TACT SW 2P2T 1102A-1F	1
2500-061001-050		6PIN 100MM 1CONN CABLE AWG#28 2MMP	1
3100-000000-017	D101	LED 5MM AMBER/BLUE COLOR WHITE DIFFUSED(CT-3390BW)	1
4897-150170-001		HK970 POWER OFF/ON BOARD REV D	1

HK970 VOL LED BOARD (9497-015000-191)

Part Number	Reference	Description	Usage
1100-333043-000	C201 C202	CERAMIC CAP. 0.033UF/50V +-10%	2
2300-004000-000	CN101	STRAIGHT CONN. WAFER 4 PINS 2mmP	1
2409-020200-007	SW201	ROTARY ENCODER EC-12E24204A9	1
3100-000000-023	D201-D204	LED BLUE COLOR ϕ 5MM ROUND HEAD	4
4897-150190-001		HK970 VOL LED BOARD REV E	1

HK970 MCU BOARD (9497-015000-231)

Part Number	Reference	Description	Usage
1001-001316-000	R313	CARBON FILM RESISTOR 100 OHM 1/6 W +-5%	1
1001-002316-000	R320 R326	CARBON FILM RESISTOR 1K OHM 1/6 W +-5%	2
1001-003316-000	R301/R314/R315/R325/R330/R331	CARBON FILM RESISTOR 10K OHM 1/6 W +-5%	6
1001-004316-000	R324	CARBON FILM RESISTOR 100K OHM 1/6 W +-5%	1
1002-000316-000	R321	CARBON FILM RESISTOR 20 OHM 1/6W +-5%	1
1003-001316-000	R316	CARBON FILM RESISTOR 300 OHM 1/6W +-5%	1
1004-703316-000	R327-R329	CARBON FILM RESISTOR 47K OHM 1/6 W +-5%	3
1044-702318-401	RN303-RN305	RESISTOR NETWORK 4K7X6 1/8W TYPE A 7PIN	3
1044-702318-402	RN301 RN302	RESISTOR NETWORK 4K7X8 1/8W TYPE A 9PIN	2
1100-101044-001	C17	CERAMIC CAP. 100P/50V +-20% Y5P	1
1100-103043-000	C2-C5, C13 C18, C308	CERAMIC CAP. 0.01uF/50V +-10%	11
1100-151044-000	C312, C313	CERAMIC CAP. 150PF/50V +-20%	2
1102-101014-001	C301 C306 C309	MINI E. CAP 100UF/16V +-20%	3
1102-101034-000	C314	ELECT.CAP. 100UF/35V +-20%	1
1106-104044-000	C1 C10 C11 C12 C15 C19 C3	MONO CAP. 0.1UF/50V +-20%	10
1181-300042-000	C311	CERAMIC CAP. 30PF/50V +-5% NPO	1
1300-901400-100	Q303	TRANSISTOR NPN 9014C CENTRE B TO92	1
1301-737002-000	Q302A	TRANSISTOR 2SB737Q TO-92 PNP (佛山無線電四廠)	1
1402-511201-200	D303 D304	ZENER DIODE 5.1V 1/2W	2
1500-227300-100	L301 L302	INDUCTOR 2.2uH +-10%	2
1600-800002-000	X301	CRYSTAL 8.00Mhz 12PF +-30PPM HC49U	1
2300-002000-000	CN303	STRAIGHT CONN. WAFER 2 PINS 2mmP*	1
2300-003000-001	CN310	STRAIGHT CONN WAFER 3PIN 2MMP JST	1
2300-003100-004	CN301	STRAIGHT CONN WAFER 3 PINS 2.5MM JST	1
2300-004000-000	CN308	STRAIGHT CONN. WAFER 4 PINS 2mmP	1
2300-006010-000	CN304	HORIZONTAL CONN. WAFER 6 PINS 2mmP	1
2300-011000-000	CN307 CN309	STRAIGHT CONN. WAFER 11PINS 2MMP	2
2301-016901-000	CN305	16PIN FILM TYPE CABLE STRAIGHT CONN	1
2400-020210-000	SW302 SW303 SW304 SW305 SW306 SW307 SW308 SW309	TACT SWITCH 2P2T SMT 5MM	8
2500-040700-150		4PIN 70MM 1CONN CABLE AWG#28 UL1571 2mmP	1
3001-203801-000	U304	INFRARED SENSOR IRM-2038 NO SHIELD	1
3106-221301-000	VFD30 1	VFD22-1301F	1
4148-701093-400	U301	I.C HT48R70A-1 48 PIN SSOP HOLTEK	1
4175-712122-500	U306	I.C LC75712E QFP64 SANYO	1
4897-150230-001		HK970 MCU BOARD REV F	1

Part List

HK970/230

HK970 POWER SUPPLY BOARD (9497-015000-071)

Part Number	Reference	Description	Usage
1001-000320-000	R604	CARBON FILM RESISTOR 10 OHM 2W +-5%	1
1001-002316-000	R12 R17 R4	CARBON FILM RESISTOR 1K OHM 1/6 W +-5%	3
1001-003316-000	R16 R18 R619	CARBON FILM RESISTOR 10K OHM 1/6 W +-5%	3
1001-004316-000	R10 R8	CARBON FILM RESISTOR 100K OHM 1/6 W +-5%	2
1002-203316-000	R11 R9	CARBON FILM RESISTOR 22K OHM 1/6 W +-5%	2
1004-701316-000	R1 R13 R14 R2 R618	CARBON FILM RESISTOR 470 OHM 1/6 W +-5%	5
1004-702316-000	R6 R7	CARBON FILM RESISTOR 4.7K OHM 1/6 W +-5%	2
1004-703316-000	R15 R617	CARBON FILM RESISTOR 47K OHM 1/6 W +-5%	2
1006-800316-000	R622 R623	CARBON FILM RESISTOR 68 OHM 1/6W +-5%	2
1100-104044-000	C602 C607 C609 C612 C613 C616 C617 C618 C621 C73	CERAMIC CAP. 0.1uF/50V +-20%	10
1102-101024-000	C3 C4 C5 C6	ELECT. CAP. 100UF/25V +-20%	4
1102-220024-000	C1 C2	ELECT. CAP. 22UF/25V +-20%	2
1102-221024-000	C614 C615 C619	ELECT. CAP. 220UF/25V +-20%	3
1102-222024-000	C606	ELECT. CAP. 2200UF/25V +-20%	1
1102-471014-000	C608	ELECT. CAP. 470uF/16V +-20% 8X12MM	1
1102-471024-002	C601 C610 C611	ELECT. CAP. 470uF/25V +-20% 10x12.5mm	3
1300-945000-105	Q612 Q613	TRANSISTOR NPN KSC945C-Y TO92 (E,C,B)	2
1301-855000-100	Q611 Q614	TRANSISTOR PNP SS8550C TO-92 (SAMSUNG)	2
1308-330300-100	Q1 Q608	TR NPN FJN3303R WITH 22K 1:1 TO 92 ECB	2
1401-101000-000	D605 D606	BRIDGE RECTIFIER DB101 50V 1A UL	2
1402-471201-200	D1	ZENER DIODE 4.7V 1/2W	1
1503-000000-100	L601	BEAD COIL FB-35608 C.T.C.	1
2300-003000-001	CN3 CN4	STRAIGHT CONN WAFER 3PIN 2MMP JST	2
2300-005100-001	CN605	STRAIGHT CONN WAFER 5PINS 2.5MMP JST (JAPAN)	1
2300-008000-000	CN603	STRAIGHT CONN. WAFER 8 PINS 2mmP	1
2300-009000-000	CN602 CN606	STRAIGHT CONN. WAFER 9 PINS 2MMP	2
2301-016901-000	CN604	16PIN FILM TYPE CABLE STRAIGHT CONN	1
4030-100000-001	F602 F603	SLOW BLOW MICRO FUSE 1A	2
4030-125000-005	F601	FUSE T1A 250V GLASS TUBE BSI/VDE/UL/CSA	1
4031-000003-002	F601	FUSE HOLDER 5X20MM HF-003A MILKY (HOLLYLAND)	1
4145-600001-600	U1	I.C. NJM4560L 8PINS SIL (NJRC)	1
4178-050334-700	U601	I.C. L7805CV TO220 THOMSON	1
4178-120301-600	U604	I.C. NJM7812FA	1
4178-150301-800	U603	I.C. LM7815 TO220 N.S.	1
4179-150301-800	U602	I.C. LM7915 TO220 N.S.	1
4181-700010-000	U2	I.C. LTV817B LITON	1
4897-150070-001		HK970 POWER SUPPLY BOARD REV D	1
6531-150222-000		REGULATOR HEATSINK PLATE	1
6542-110203-001		CD421 HEAT SINK	2
7003-006003-111		SCREW M3X6 B.T.B. B/H (BLACK)	4

HK970 REMOTE IN/OUT BOARD (9497-015000-081)

Part Number	Reference	Description	Usage
1001-001316-000	R401	CARBON FILM RESISTOR 100 OHM 1/6 W +-5%	1
1002-701316-000	R406	CARBON FILM RESISTOR 270 OHM 1/6W +-5%	1
1003-902316-000	R403	CARBON FILM RESISTOR 3.9K OHM 1/6 W +-5%	1
1004-700316-000	R404 R405	CARBON FILM RESISTOR 47 OHM 1/6W +-5%	2
1004-703316-000	R402	CARBON FILM RESISTOR 47K OHM 1/6 W +-5%	1
1007-500316-000	R407	CARBON FILM RESISTOR 75 OHM 1/6W +-5%	1
1102-101014-000	C403	ELECT. CAP. 100uF/16V +-20% 105°C	1
1102-470014-000	C402	ELECT. CAP. 47uF/16V +-20%	1
1301-200300-100	Q401	TRANSISTOR PNP KSR2003 (SAMSUNG)	1
1504-100300-100	L401 L402 L403	AXIAL INDUCTOR 10UH +-10%	3
2300-003000-001	CN401	STRAIGHT CONN WAFER 3PIN 2MMP JST	1
2321-003911-002	J401 J402	MIC JACK 3.5MM JY-3510*01-130	2
4181-700010-000	U401	I.C. LTV817B LITON	1
4897-150080-001		HK970 REMOTE IN/OUT BOARD REV B	1

Part List

HK970/230

HK970 RIGHT CHANNEL POWER AMP BOARD (9497-015000-091)

Part Number	Reference	Description	Usage
1011-000016-020	R24 R26	METAL FILM RESISTOR 10 OHM 1/6W +-1% AXIAL TAPE	2
1011-001018-020	R28 R29 R31 R37	METAL FILM RESISTOR 100 OHM 1/8W +-1% AXIAL TAPE	4
1011-002018-020	R2 R22	METAL FILM RESISTOR 1K OHM 1/8W +-1% AXIAL TAPE	2
1011-003016-020	R33	METAL FILM RESISTOR 10K 1/6W +-1% AXIAL TAPE	1
1011-004018-020	R1	METAL FILM RESISTOR 100K OHM 1/8W +-1% AXIAL TAPE	1
1011-072016-020	R11	METAL FILM RESISTOR 1.07K OHM 1/6W +-1% AXIAL TAPE	1
1011-201016-020	R19 R20	METAL FILM RESISTOR 120 OHM 1/6W +-1% AXIAL TAPE	2
1011-503016-020	R18 R25 R34 R42	METAL FILM RESISTOR 15K OHM 1/6W +-1% AXIAL TAPE	4
1011-801016-020	R6 R7	METAL FILM RESISTOR 180 OHM 1/6W +-1% AXIAL TAPE	2
1012-002016-020	R4 R5	METAL FILM RESISTOR 2K OHM 1/6W +-1% TAPE	2
1012-202018-020	R46	METAL FILM RESISTOR 2.2K OHM 1/8W +-1% AXIAL TAPE	1
1012-203018-020	R39 R40	METAL FILM RESISTOR 22K OHM 1/8W +-1% AXIAL TAPE	2
1012-491016-020	R9	METAL FILM RESISTOR 249 OHM 1/6W +-1% TAPE	1
1013-301016-020	R27	METAL FILM RESISTOR 330 OHM 1/6W +-1% AXIAL TAPE	1
1013-302016-020	R38	METAL FILM RESISTOR 3.3K OHM 1/6W +-1% AXIAL TAPE	1
1013-323016-020	R10 R3	METAL FILM RESISTOR 33.2K OHM 1/6W +-1% TAPE	2
1014-701018-020	R12 R13 R14 R15 R16 R17	METAL FILM RESISTOR 470 OHM 1/8W +-1% AXIAL TAPE	6
1014-703018-020	R41 R8	METAL FILM RESISTOR 47K 1/8W +-1% AXIAL TAPE	2
1015-602016-020	R21	METAL FILM RESISTOR 5.6K OHM 1/6W +-1% AXIAL TAPE	1
1065-001600-171	VR1	SEMI-FIXED RESISTOR 500 OHM +-30% PA0630-VA1-B501	1
1092-208310-000	R30 R32 R35 R36	METAL OXIDE RESISTOR 0.22 OHM 1W +/-5% AXIAL TAPE	4
1095-107310-000	R43	METAL OXIDE RESISTOR 5.1 OHM 1W +/-5% AXIAL TAPE	1
1096-802320-000	R44 R45	METAL OXIDE RESISTOR 6.8K OHM 2W +-5% AXIAL TAPE	2
1100-104044-000	C10	CERAMIC CAP. 0.1uF/50V +-20%	1
1101-104063-000	C12	POLYESTER/MYLAR CAP. 0.1UF/100V +-10%	1
1102-100024-000	C7	ELECT. CAP. 10UF/25V +-20%	1
1102-101024-000	C20	ELECT. CAP. 100UF/25V +-20%	1
1102-123054-001	C17 C18	ELECT. CAP. 12000uF/63V +-20% (NICHICON)	2
1102-337044-000	C9	ELECT. CAP. 3.3uF/50V +-20%	1
1102-470054-000	C3 C4	ELECT. CAP. 47UF/63V +-20%	2
1102-471024-002	C2 C5	ELECT. CAP. 470uF/25V +-20% 10x12.5mm	2
1106-104044-000	C28 C29	MONO CAP. 0.1UF/50V +-20%	2
1114-181062-000	C8	POLYPROPYLENE CAP. 180P/100V +-5%	1
1114-224093-000	C13 C14	METALLIZED POLYPROPYLENE CAP. 0.22UF/250V +-10%	2
1114-271062-000	C1	POLYPROPYLENE CAP. 270PF 100V +-5%	1
1181-307042-000	C6	CERAMIC CAP. 3PF/50V +-5% NPO	1
1300-060000-100	Q3 Q4	TRANSISTOR NPN MPSA06 TO92	2
1300-174000-100	Q23 Q24	TRANSISTOR NPN 2SC1740 TO-92	2
1300-224000-100	Q1 Q2	TRANSISTOR NPN 2SC2240-GR TO-92 (TOSHIBA)	2
1300-350200-800	Q12 Q9	TRANSISTOR NPN 2SC3502 TO126 (SANYO)	2
1300-422000-100	Q18 Q6	TRANSISTOR NPN BF422 (PHILIPS)	2
1300-479300-200	Q10 Q13	TRANSISTOR NPN 2SC4793 (TOSHIBA)	2
1300-524209-900	Q16 Q17	TRANSISTOR NPN 2SC5242-O (TOSHIBA)	2
1301-138000-800	Q14 Q8	TRANSISTOR PNP 2SA1380 TO126 (SANYO)	2
1301-183700-200	Q15	TRANSISTOR PNP 2CA1837 (TOSHIBA)	1
1301-196209-900	Q19 Q20	TRANSISTOR PNP 2SA1962-O (TOSHIBA)	2
1301-423000-100	Q5 Q7	TRANSISTOR PNP BF423 (PHILIPS)	2
1301-560000-100	Q21	TRANSISTOR PNP MPSA56 TO92	1
1401-140040-000	D5 D7D8	DIODE RECTIFIER 1N4004	3
1401-141480-000	D1 D10 D11 D12 D2 D6	DIODE 1N4148	6
1401-802000-000	BR1	DIODE BRIDGE RS802	1
1404-181001-200	D3 D4	HIGH VOLTAGE SWITCHING DIODE 1SS81(HITACH) TAPE	2
1502-047400-900	L3	AUDIO FILTER L=4UH R=1 +-20% LR0515-R40M	1
1503-000000-100	L1 L2	BEAD COIL FB-35608 C.T.C.	2
2300-002000-001	CN1	STRAIGHT CONN WAFER 2PIN 2MMP JST	1
2300-002100-000	TP1	STRAIGHT CONN. WAFER 2 PINS 2.5mmP	1
2300-003400-001	CN3	STRAIGHT CONN WAFER 3PIN 3.96MMP JST	1
2300-009000-001	CN2	STRAIGHT CONN WAFER 9PINS 2MMP JST	1
2333-001909-000		SPEAKER JACK DY-024 BLACK	2
2333-001909-001		SPEAKER JACK DY-024 RED	2
2370-020110-000	J1	RIGHT ANGLE HEADER 20PIN 2.5MMP	1
4014-170275-000	SW1	THERMAL PROTECT SWITCH 17AM027A5-32 (TI)	1
4030-618004-001	F1 F2	FUSE T-4A/250V 618004 5X20MM	2
4050-210000-000	RL2 RL3	RELAY DC 12V 2P2T 5A/250VAC 25(H)X12(W)X28(L)	2
4080-000006-001	Q16 Q17 Q19 Q20	MICA TRANS. WASHER 25X29X0.15(MM) (AP10692/2)	4
4080-058016-000		MICA WASHER 58X16X0.15t	1
4867-000090-002		RIGHT CHANNEL AMPLIFIER BOARD REV B	1
4897-150540-001		HK970 SPEAKER JOINT BOARD REV A	1
6097-150004-000		SPEAKER-JACK-BASE	1
6567-150008-000		HK670 HEAT SINK	1
6597-150003-000		LUG	4
7002-010010-111		SCREW M2X10 M/C TYPE B/H BLACK	5
7003-006002-111		SCREW M3X6 P.T.P. B/H (BLACK)	2
7003-008002-111		SCREW M3X8 P.T.P. B/H (BLACK)	2
7003-014010-111		SCREW M3X14 M/C TYPE B/H BLK	4
7102-304636-040		NYLON WASHER 2.3X4.6X3.6	5
7103-206504-081	Q16 Q17 Q19 Q20	EX-TOOTHED LOCK WASHER M3 (BLK)	4

Part List

HK970/230

HK970 STANDBY POWER BOARD (9497-015000-111)

<u>Part Number</u>	<u>Reference</u>	<u>Description</u>	<u>Usage</u>
1001-000314-000	R502	CARBON FILM RESISTOR 10 OHM 1/4W +-5%	1
1001-002316-000	R504 R507 R510	CARBON FILM RESISTOR 1K OHM 1/6 W +-5%	3
1001-003316-000	R505	CARBON FILM RESISTOR 10K OHM 1/6 W +-5%	1
1005-007314-000	R508 R509	CARBON FILM RESISTOR 5 OHM 1/4W +- 5%	2
1006-802316-000	R503	CARBON FILM RESISTOR 6.8K OHM 1/6W +-5%	1
1100-104044-000	C504 C506	CERAMIC CAP. 0.1uF/50V +-20%	2
1100-223043-000	C502 C509	CERAMIC CAP. 0.022UF/50V +-10%	2
1102-101034-000	C505 C507	ELECT.CAP. 100UF/35V +-20%	2
1102-221004-001	C508	ELECT. CAP. 220UF/10V +-20% H7MM MINI	1
1102-221034-000	C503	ELECT. CAP. 220UF/35V +-20%	1
1102-471014-000	C501	ELECT. CAP. 470uF/16V +-20% 8X12MM	1
1300-945000-105	Q501	TRANSISTOR NPN KSC945C-Y TO92 (E,C,B)	1
1301-855000-100	Q502	TRANSISTOR PNP SS8550C TO-92 (SAMSUNG)	1
1301-901500-100	Q503	TRANSISTOR PNP 9015C TO92	1
1401-101000-000	U503	BRIDGE RECTIFIER DB101 50V 1A UL	1
1401-140040-000	D502 D503 D504 D505	DIODE RECTIFIER 1N4004	4
1401-141480-000	D501 D507	DIODE 1N4148	2
1402-300001-200	D506	DIODE DZ30V	1
2300-002000-001	CN503CN504	STRAIGHT CONN WAFER 2PIN 2MMP JST	2
2300-003100-004	CN502	STRAIGHT CONN WAFER 3 PINS 2.5MM JST	1
2300-004000-000	CN501	STRAIGHT CONN. WAFER 4 PINS 2mmP	1
4050-000005-002	RL501	RELAY DC 5V 20.8(L)X12HX9.9W 2P2T 120VAC/60V DC 2A	1
4178-050310-000	U502	I.C. LM78L05 TO92	1
4897-150110-001		HK970 STANDBY POWER BOARD REV D	1

Part List

HK970/230

HK970 PRE-AMP BOARD (9497-015000-331)

Part Number	Reference	Description	Usage
1001-001316-000	R104 R105 R11 R12 R7 R704 R705 R706 R707 R712 R713 R716 R717 R8	CARBON FILM RESISTOR 100 OHM 1/6 W +-5%	14
1001-002316-000	R753 R778	CARBON FILM RESISTOR 1K OHM 1/6 W +-5%	2
1003-300316-000	R701 R702 R703	CARBON FILM RESISTOR 33 OHM 1/6W +-5%	3
1011-002016-000	R1 R106 R107 R108 R109 R21 R82 R83 R84 R85 R86 R87 R22 R23 R29 R3 R30 R33 R34 R4 R5 R56 R57 R6 R66 R78 R79 R80 R8 R83 R84 R85 R86 R87 R88 R89 R9 R97 R98	METAL FILM RESISTOR 1K OHM 1/6W +-1%	43
1011-003016-000	R16 R17 R18 R19 R20 R21 R	METAL FILM RESISTOR 10K OHM 1/6W +-1%	16
1011-004016-000	R718 R719 R731 R732	METAL FILM RESISTOR 100K 1/6W +-1%	4
1012-003018-000	R769 R771	METAL FILM RESISTOR 20K OHM 1/8W +-1%	2
1012-201018-000	R7112R7114	METAL FILM RESISTOR 220 OHM 1/8W +-1%	2
1012-402016-000	R748 R751	METAL FILM RESISTOR 2.4K OHM 1/6W +-1%	2
1012-702016-000	R7113R7115	METAL FILM RESISTOR 2.7K OHM 1/6W +-1%	2
1013-302016-000	R774 R775	METAL FILM RESISTOR 3.3K OHM 1/6W +-1%	2
1013-304018-000	R13 R14 R28 R51	METAL FILM RESISTOR 330K OHM 1/8W +-1%	4
1014-701016-000	R739 R740	METAL FILM RESISTOR 470 OHM 1/6W +-1%	2
1014-703016-000	R10 R100 R101 R102 R103 R	METAL FILM RESISTOR 47K OHM 1/6W +-1%	16
1015-604018-000	R735 R736	METAL FILM RESISTOR 560K OHM 1/8W +-1%	2
1016-801016-000	R737 R738	METAL FILM RESISTOR 680 OHM 1/6W +-1%	2
1016-802018-000	R747 R750	METAL FILM RESISTOR 6.8K 1/8W +-1%	2
1062-003404-131	VR701	VAR 20K BX2 +-20% ROTARY DUAL RD1610GOA0X-VAI-410	1
1100-101042-000	C1 C2	CERAMIC CAP. 100PF/50V +-5%	2
1100-101044-001	C701 C702 C703 C737 C746	CERAMIC CAP. 100P/50V +-20% Y5P	9
1100-221043-000	C80 C81 C82 C83 C84 C85 C	CERAMIC CAP. 220pF/50V +- 10%	12
1100-331043-000	C3 C4	CERAMIC CAP. 330PF/50V +-10%	2
1101-102062-000	C733 C734	POLYESTER/MYLAR CAP. 0.001UF/100V +-5%	2
1101-182062-000	C738 C739	POLYESTER/MYLAR CAP. 0.0018UF/100V +-5%	2
1101-562062-000	C731 C732 C743 C744	POLYESTER/MYLAR CAP. 5600PF/100V +-5%	4
1102-100014-001	C742 C745 C747 C748	ELECT. CAP. 10UF/16V +-20% (MINI)	4
1102-101014-001	C11 C12 C14 C15 C6 C65 C8	MINI E. CAP 100UF/16V +-20%	27
1102-470004-002	C66 C67 C68 C704 C705 C718 C719	C735 C736 C74 C749 C75 C752 C78 C782 C79 C793 C794 C797 C798	
1102-471014-000	C740 C741	ELECT. CAP. 47UF/10V +-20% MINI SIZE	2
1105-101024-000	C23 C24	ELECT. CAP. 470uF/16V +-20% 8X12MM	2
1105-101024-000	C785 C787	NON-POLARIZED CAP 100UF/25V +-20%	2
1106-104044-000	C16 C17 C32 C34 C7 C706 C	MONO CAP. 0.1UF/50V +-20%	19
1114-201042-001	C92 C93 C94 C95	POLYPROPYLENE CAP. 200P/50V +-5% (RODAN)	4
1181-100042-000	C10 C5C763 C765 C795 C79	CERAMIC CAP. 10PF/50V +-5% NPO	6
1300-805000-100	Q1 Q705	TRANSISTOR NPN 8050D TO92	2
1401-141480-000	D1 D702	DIODE 1N4148	2
1504-470300-100	L701 L702	AXIAL INDUCTOR 47UH +-10%	2
2300-002000-001	CN703CN704	STRAIGHT CONN WAFER 2PIN 2MMP JST	2
2300-003000-001	CN702	STRAIGHT CONN WAFER 3PIN 2MMP JST	1
2300-009000-000	CN705	STRAIGHT CONN. WAFER 9 PINS 2MMP	1
2330-003990-001	RCA1 RCA701	RCA JACK 2P 202 R/W (GOLD)	2
2330-006990-001	RCA3	RCA JACK 4P 402 R/R/W/W WITH SHIELD PLATE (GOLD)	1
2330-009990-001	RCA2 RCA4	RCA JACK 6P 602 R/R/W/W/W WITH SHIELD PLATE GOLD	2
2370-009300-000	CN707	9PIN 2.54MMP STRAIGHT HEADER 201S-1*9P(11/2.54/3)	1
2600-100804-800	..34050-000005-002	80MM JUMPER WIRE AWG#26 WHITE	1
4050-000005-002	RL1 RL701	RELAY DC 5V 20.8(L)X12HX9.9W 2P2T 120VAC/60V DC 2A	2
4120-100101-600	U5	I.C. NJU201A 28PINS SOP (JRC)	1
4127-500100-000	U701 U702 U705 U706	I.C. OP275GS 8PIN SOIC ANALOG DEVICE	4
4155-320101-600	U707 U709	I.C. NJM5532M SOP8 (JRC)	2
4173-110051-600	U1	IC NJU7311L 28P DIP JRC	1
4173-130051-600	U6	IC NJU7313L 28P DIP JRC	1
4188-160100-000	IC701	I.C. WM8816 SOIC 16PIN WOLFSON	1
4897-150330-001		HK970 PRE-AMP BOARD REV H	1

Part List

HK970/230

HK970 TONE BOARD (9497-015000-561)

Part Number	Reference	Description	Usage
1001-001316-000	R708 R709 R710 R711	CARBON FILM RESISTOR 100 OHM 1/6 W +-5%	4
1011-002016-000	R760 R767	METAL FILM RESISTOR 1K OHM 1/6W +-1%	2
1011-003016-000	R756 R757 R758 R763 R764	METAL FILM RESISTOR 10K OHM 1/6W +-1%	10
1011-005016-000	R755 R762	METAL FILM RESISTOR 1M OHM 1/6W +-1%	2
1014-702016-000	R744 R745	METAL FILM RESISTOR 4.7K OHM 1/6W +-1%	2
1015-102016-000	R7101R784 R789 R796	METAL FILM RESISTOR 5.1K OHM 1/6W +-1%	4
1015-602016-000	R7104R7105 R7108 R7109	METAL FILM RESISTOR 5.6K OHM 1/6W +-1%	4
1016-802018-000	R754 R759 R761 R766	METAL FILM RESISTOR 6.8K 1/8W +-1%	4
1017-502018-000	R7100R7102 R7106 R778 R7	METAL FILM RESISTOR 7.5K OHM 1/8W +-1%	10
1018-202018-000	R7103 R7107	METAL FILM RESISTOR 8.2K OHM 1/8W +-1%	2
1019-092016-000	R743 R746	METAL FILM RESISTOR 9.09K OHM 1/6W +-1%	2
1100-101043-000	C1 C2	CERAMIC CAP. 100PF/50V +-10%	2
1101-104062-000	C770 C771 C778 C779	POLYESTER/MYLAR CAP. 0.1UF/100V +-5%	4
1101-222062-000	C772 C773 C780 C781	POLYESTER/MYLAR CAP. 2200PF/100V +-5%	4
1101-472062-000	C768 C775	POLYESTER/MYLAR CAP. 4700PF/100V +-5%	2
1102-100014-001	C758 C767 C774 C777	ELECT. CAP. 10UF/16V +-20% (MINI)	4
1102-101014-000	C710 C711 C714 C715	ELECT. CAP. 100uF/16V +-20% 105°C	4
1105-100024-000	C761 C762	NON-POLARIZED CAP. 10UF/25V +-20%	2
1106-104044-000	C708 C709 C712 C713 C789	MONO CAP. 0.1UF/50V +-20%	8
1181-100042-000	C769 C776	CERAMIC CAP. 10PF/50V +-5% NPO	2
2300-011010-000	CN709	RIGHT ANGLE CONN WAFER 11 PIN 2.0MMP	1
2350-009301-000	CN708	9PIN 2.54MMP STRAIGHT SOCKET 203S-1*9P(H=8.5MM)	1
4127-500100-000	U703 U704	I.C. OP275GS 8PIN SOIC ANALOG DEVICE	2
4140-510100-000	IC702IC703 IC704 IC705	IC CD4051 8 CHANNEL SOIC TEXAS	4
4897-150560-001	0.29497-015001-071	HK970 TONE CONTROL BOARD REV F	1

HK970 POWER SWITCH BOARD (9497-015001-071)

1083-305312-000	R901	CERAMIC PACKAGE RESISTOR 3.3M OHM +-5% 1/2W	1
1084-705312-000	R902	CERAMIC PACKAGE RESISTOR 4.7M OHM 1/2W +-5% (UL.)	1
1110-103094-001	C901	X-TYPE CAP.0.01uF/AC 250V +-20% MURATA KH103M	1
1110-104094-001	C902 C903	X-TYPE CAP 0.1UF 250VAC +-20% ECQU2A104ML	2
1801-501300-000	TR901	THREMAL RESISTOR 5D-13(WELTRONICS)	1
2500-021601-040	TO CN504	2PIN 160MM 1CONN CABLE AWG#26 2MMP	1
4001-780000-000	L901	COLL TOROID TC2006-6R8M-H	1
4050-700500-000	RL901	RELAY DC5V 1P1T ME-7-005-HL 24.5(H)*23.8(L)*9.5(W)	1
4897-150070-101		HK970 POWER SWITCH BD REV B	1

HK970 LEFT CHANNEL POWER AMP BOARD (9497-015001-091)

Part Number	Reference	Description	Usage
1011-000016-020	R24 R26	METAL FILM RESISTOR 10 OHM 1/6W +-1% AXIAL TAPE	2
1011-001018-020	R28 R29 R31 R37	METAL FILM RESISTOR 100 OHM 1/8W +-1% AXIAL TAPE	4
1011-002018-020	R2 R22	METAL FILM RESISTOR 1K OHM 1/8W +-1% AXIAL TAPE	2
1011-003016-020	R33	METAL FILM RESISTOR 10K 1/6W +-1% AXIAL TAPE	1
1011-004018-020	R1	METAL FILM RESISTOR 100K OHM 1/8W +-1% AXIAL TAPE	1
1011-072016-020	R11	METAL FILM RESISTOR 1.07K OHM 1/6W +-1% AXIAL TAPE	1
1011-201016-020	R19 R20	METAL FILM RESISTOR 120 OHM 1/6W +-1% AXIAL TAPE	2
1011-503016-020	R18 R25 R34 R42	METAL FILM RESISTOR 15K OHM 1/6W +-1% AXIAL TAPE	4
1011-801016-020	R6 R7	METAL FILM RESISTOR 180 OHM 1/6W +-1% AXIAL TAPE	2
1012-002016-020	R4 R46R5	METAL FILM RESISTOR 2K OHM 1/6W +-1% TAPE	3
1012-491016-020	R9	METAL FILM RESISTOR 249 OHM 1/6W +-1% TAPE	1
1013-301016-020	R27	METAL FILM RESISTOR 330 OHM 1/6W +-1% AXIAL TAPE	1
1013-323016-020	R10 R3	METAL FILM RESISTOR 33.2K OHM 1/6W +-1% TAPE	2
1014-701018-020	R12 R13 R14 R15 R16 R17	METAL FILM RESISTOR 470 OHM 1/8W +-1% AXIAL TAPE	6
1014-703018-020	R41 R8	METAL FILM RESISTOR 47K 1/8W +-1% AXIAL TAPE	2
1015-602016-020	R21	METAL FILM RESISTOR 5.6K OHM 1/6W +-1% AXIAL TAPE	1
1065-001600-171	VR1	SEMI-FIXED RESISTOR 500 OHM +-30% PA0630-VA1-B501	1
1092-208310-000	R30 R32 R35 R36	METAL OXIDE RESISTOR 0.22 OHM 1W +/-5% AXIAL TAPE	4
1095-107310-000	R43	METAL OXIDE RESISTOR 5.1 OHM 1W +/-5% AXIAL TAPE	1
1096-802320-000	R44 R45	METAL OXIDE RESISTOR 6.8K OHM 2W +-5% AXIAL TAPE	2
1101-104063-000	C12	POLYESTER/MYLAR CAP. 0.1UF/100V +-10%	1
1102-100024-000	C7	ELECT. CAP. 10UF/25V +-20%	1
1102-101024-000	C20	ELECT. CAP. 100UF/25V +-20%	1
1102-123054-001	C17 C18	ELECT. CAP. 12000uF/63V +-20% (NICHICON)	2
1102-337044-000	C9	ELECT. CAP. 3.3uF/50V +-20%	1
1102-470054-000	C3 C4	ELECT. CAP. 47UF/63V +-20%	2
1102-471024-002	C2 C5	ELECT. CAP. 470uF/25V +-20% 10x12.5mm	2
1106-104044-000	C28 C29	MONO CAP. 0.1UF/50V +-20%	2
1114-181062-000	C8	POLYPROPYLENE CAP. 180P/100V +-5%	1
1114-224093-000	C13 C14	METALLIZED POLYPROPYLENE CAP. 0.22UF/250V +-10%	2
1114-271062-000	C1	POLYPROPYLENE CAP. 270PF 100V +-5%	1
1181-307042-000	C6	CERAMIC CAP. 3PF/50V +-5% NPO	1
1300-060000-100	Q3 Q4	TRANSISTOR NPN MP5A06 TO92	2
1300-174000-100	Q23 Q24	TRANSISTOR NPN 2SC1740 TO-92	2
1300-224000-100	Q1 Q2	TRANSISTOR NPN 2SC2240-GR TO-92 (TOSHIBA)	2
1300-350200-800	Q12 Q9	TRANSISTOR NPN 2SC3502 TO126 (SANYO)	2
1300-422000-100	Q18 Q6	TRANSISTOR NPN BF422 (PHILIPS)	2
1300-479300-200	Q10 Q13	TRANSISTOR NPN 2SC4793 (TOSHIBA)	2
1300-524209-900	Q16 Q17	TRANSISTOR NPN 2SC5242-O (TOSHIBA)	2
1301-138000-800	Q14 Q8	TRANSISTOR PNP 2SA1380 TO126 (SANYO)	2
1301-183700-200	Q15	TRANSISTOR PNP 2CA1837 (TOSHIBA)	1
1301-196209-900	Q19 Q20	TRANSISTOR PNP 2SA1962-O (TOSHIBA)	2
1301-423000-100	Q5 Q7	TRANSISTOR PNP BF423 (PHILIPS)	2
1401-140040-000	D5 D7D8	DIODE RECTIFIER 1N4004	3
1401-141480-000	D1 D10D11 D2 D6	DIODE 1N4148	5
1401-802000-000	BR1	DIODE BRIDGE RS802	1
1404-181001-200	D3 D4	HIGH VOLTAGE SWITCHING DIODE 1SS81(HITACH) TAPE	2
1502-047400-900	L3	AUDIO FILTER L=4UH R=1 +-20% LR0515-R40M	1
1503-000000-100	L1 L2	BEAD COIL FB-35608 C.T.C.	2
2300-002000-001	CN1	STRAIGHT CONN WAFER 2PIN 2MMP JST	1
2300-002100-000	TP1	STRAIGHT CONN. WAFER 2 PINS 2.5mmP	1
2300-003400-001	CN3	STRAIGHT CONN WAFER 3PIN 3.96MMP JST	1
2300-008000-002	CN2	STRAIGHT CONN WAFER 8PINS 2MMP JST	1
2333-001909-000		SPEAKER JACK DY-024 BLACK	2
2333-001909-001		SPEAKER JACK DY-024 RED	2
2370-020110-000	J1	RIGHT ANGLE HEADER 20PIN 2.5MMP	1
4014-170275-000	SW1	THERMAL PROTECT SWITCH 17AM027A5-32 (TI)	1
4030-618004-001	F1 F2	FUSE T-4A/250V 618004 5X20MM	2
4031-050100-001	F1 F2	FUSE HOLDER 5X20MM PCB MOUNT WITH PLASTIC BASE	2
4050-210000-000	RL2 RL3	RELAY DC 12V 2P2T 5A/250VAC 25(H)X12(W)X28(L)	2
4080-000006-001	Q16 Q17 Q19 Q20	MICA TRANS. WASHER 25X29X0.15(MM) (AP10692/2)	4
4080-058016-000		MICA WASHER 58X16X0.15t	1
4867-000090-102		LEFT CHANNEL AMPLIFIER BOARD REV B	1
4897-150540-001		HK970 SPEAKER JOINT BOARD REV A	1
6097-150004-000		SPEAKER-JACK-BASE	1
6567-150008-000		HK670 HEAT SINK	1
6597-150003-000		LUG	4
7002-010010-111		SCREW M2X10 M/C TYPE B/H BLACK	5
7003-006002-111		SCREW M3X6 P.T.P. B/H (BLACK)	2
7003-008002-111		SCREW M3X8 P.T.P. B/H (BLACK)	2
7003-014010-111		SCREW M3X14 M/C TYPE B/H BLK	4
7102-304636-040		NYLON WASHER 2.3X4.6X3.6	5
7103-206504-081	Q16 Q17 Q19 Q20	EX-TOOTHED LOCK WASHER M3 (BLK)	4

Part List

HK970/230

HK970 PACKAGING MATERIAL

<u>Part Number</u>	<u>Description</u>	<u>Usage</u>
2617-210004-001	3.5MM MIC CABLE 2CONN 1000MM AWG#26 UL2468	1
4090-150001-000	AA ALKALINE BATTERIES	2
5000-971500-101	POLYFOAM LEFT FOR HK 970	1
5000-971500-201	POLYFOAM RIGHT FOR HK 970	1
5013-671500-000-04	HARMAN KARDON HK970(230V) CARTON BOX W/PRINTED	1
5100-838000-300	H/K SAFETY MANUAL FOR EVROPE(AC230V)	1
5100-971500-000	HARMAN KARDON HK970(230V) INST-MANUAL	1
5102-838000-000	HARMAN KARDON ADVERTISING BROCHURE (CONSIGNED)	1
5110-671500-100	TRANSFORMER "HARMAN/KARDON" UL LABEL GOLD/BLACK	1
5110-675000-100	HARMAN KARDON "MADE IN PRC" 4 LANG CB LABEL	2
5110-838000-000	INSTRUCTION LABEL	1
5113-000000-000-27	HARMAN KARDON HK675 MANUFACTURED DATE CODE LABEL	1
5113-838000-000-08	H/K HK970(230V) BARCODE S/N LABEL(YC0016-01001)	3
5200-230321-030-01	POLYBAG FOR ACCESSORIES (FL8350/FL8550)	1
5200-600600-030-01	POLYBAG FOR UNIT WARNING WORDING (6 LANGUAGES)	1
5206-500160-050	E.P.E. SHEET P-EP500160-05	1
9805-970000-001	HK970 REMOTE CONTROL UNIT	1

HK970 ELECTRONIC PARTS NOT ON PCB

<u>Part Number</u>	<u>Description</u>	<u>Usage</u>
2501-022001-140	2PIN 200MM 2CONN CABLE AWG#26 UL1430 2MMP PH	1
2501-030902-240	3PIN 90MM 2CONN CABLE AWG#26 2.5MMP	1
2501-032501-140	3PIN 250MM 2CONN CABLE AWG#26 2MMP	1
2501-035001-140	3PIN 500MM 2CONN CABLE AWG#26 UL1007 2MMP	1
2501-042201-150	4PIN 220MM 2CONN CABLE UL1571 AWG#28 2.0MMP	1
2501-082701-150	8PIN 270MM 2CONN CABLE AWG#28 UL1571 2mmP	1
2501-090801-150	9PIN 80MM 2CONN CABLE AWG#28 2MMP UL1007	1
2501-093001-150	9PIN 300MM 2CONN CABLE UL1571 AWG#28 2MMP PH	1
2503-114701-150	11PIN 470MM 2 CONN FLAT CABLE AWG#28 2MMP UL2651	1
2503-163009-090	16PIN 300MM FLAT FLEXIBLE CABLE	1
2508-115001-150	11 PIN 500MM 2 CONN FLAT CABLE #28 2MMP 1 CONN PIN	1
2511-022501-140	2PIN 250MM 2CONN SHIELD CABLE AWG#26 2MMP	1
2511-024501-150	2PIN 450MM 2CONN SHIELD CABLE AWG#28 UL2547 2MMP	1
2511-030801-160	3PIN 80MM 2CONN SHIELD CABLE UL2552 AWG#30 2mmP	1
2610-220009-004	2000MM AC CORD VDE HO5VV-F 2GX1.0MM2	1
2612-103400-200	340MM DOUBLE INSULATED WIRE AWG#18 UL1672 RED	2
3200-307541-400	TRANSFORMER 230V VDE 0696V3075TM4 (NGAI CHEONG)	1
4002-311975-000	TOROID COILS 'T31X19X7.5MM'	1
4030-618004-001	FUSE T-4A/250V 618004 5X20MM	1
4031-000002-000	FUSE HOLDER FH-B02	1
3200-729201-000	TX 230VEI35 DC8V0.2A AC2.8V0.15A	1

HK970 MECHANICAL PARTS

<u>Part Number</u>	<u>Description</u>	<u>Usage</u>
6600-180017-000	AC CORD BUSHING	1
7003-006001-111	SCREW M3X6 S.T.P. B/H (BLACK)	36
7003-010002-111	SCREW M3X10 P TYPE B/H BLK	15
7003-006001-113	SCREW M3X6 S.T.P B/H NI-PLATED	11
6600-990023-000	GROUND TERMINAL	1
7003-008002-111	SCREW M3X8 P.T.P. B/H (BLACK)	4
6597-150010-000-01	HK970 (230V) REAR-PANEL W/SILKSCREEN	1
6567-150007-000	HK670 PCB BRACKET	2
6600-210245-000	EVA PAD 20*12*13.5	3
6600-210244-000	EVA PAD 20*12*10.5	3
7104-010010-022	WASHER M4X10X1MM	4
7104-308504-162	ETW M4	4
6600-120040-000	SCREW NUT M4X7X3	4
7003-006010-111	SCREW M3X6 M.C. B/H, BLK	12
7003-006001-063	SCREW M3X6 S.T.P. W/H NI-PLATED	6
6597-150002-000-01	HK970 METAL TOP-COVER W/COLOR	1
7103-706710-022	METAL WASHER M3.7X6.7X1	2
7103-706504-162	EXTERNAL TOOTH LOCK WAHSER 3.7X6.5X0.4MM	2
6600-120030-001	NUT M3 HEX M3X5.5X2.4MM	2
6600-105001-000	HEAT SHRINK TUBE 50MM DIA L=95MM	1
6597-150004-000	SHIELDING PLATE	1
6600-220030-000	8MM NYLON STANDOFF, SCF-8, BLACK	4
6600-240036-000	HK970 INSULATION-SHEET-4	1
8597-015010-601-01	HK970 BOTTOM CABINET ASSY WITH PAINTED	1
8597-015000-300	HK970 FRONT PANEL ASSY	1
8597-015000-100	HK970 VOLUME KNOB ASSY	1
7003-006002-111	SCREW M3X6 P.T.P. B/H (BLACK)	2
8597-015020-300	LENS ASSY FOR HK970	1
7003-008001-111	SCREW M3X8 S.T.P. B/H BLK	8
7003-014010-111	SCREW M3X14 M/C TYPE B/H BLK	2
7004-010010-111	SCREW M4X10 M/C TYPE B/H BLACK	4
8597-015010-300	PLASTIC FOOT ASSY FOR HK970	4

6

5

4

3

2

1

PCB: 4897-150110-001, Rev.D

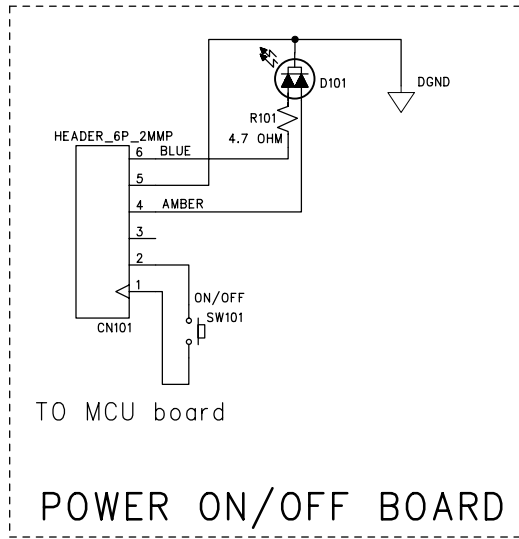

PCB: 4897-150190-001, Rev.E

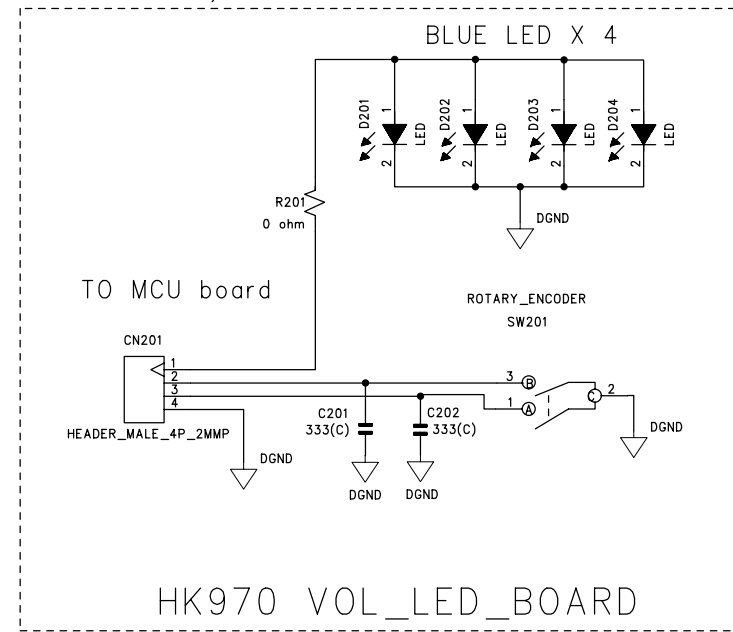

REVISION RECORD			
LTR	ECO NO:	APPROVED:	DATE:

Remark:
 - C805, C806 soldered on solder side.
 - C805, C806 soldered to GND by wire with a 0.22uF cap in series.

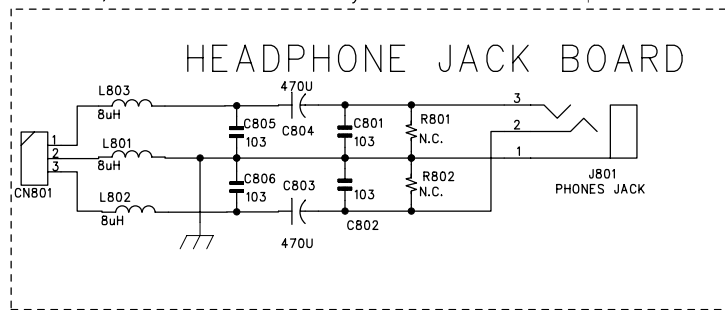

PCB: 4897-150020-001, Rev.B

FILE NAME: VOLLED_ONOFF_970_6.SCH

COMPANY:			
TITLE: HK970 FRONT BOARDS			
DRAWN:	DATED: 2005-MAR-08	CODE:	SIZE:
CHECKED:	DATED:	DRAWING NO:	REV:
QUALITY CONTROL:	DATED:		
RELEASED:	DATED:	SCALE:	SHEET: OF

YN

SCHEMATIC DRAWING
HKENF 970004-00

FILE NAME: LEFTAMP_970.SCH
DATE: 2004-10-28

MODEL NO: HK970

PART NO: 4867-000090-101
4897-150540-001

PART NAME: LEFT CHANNEL POWER AMPLIFIER
SPEAKER JOINT BOARD

RL1 is empty.

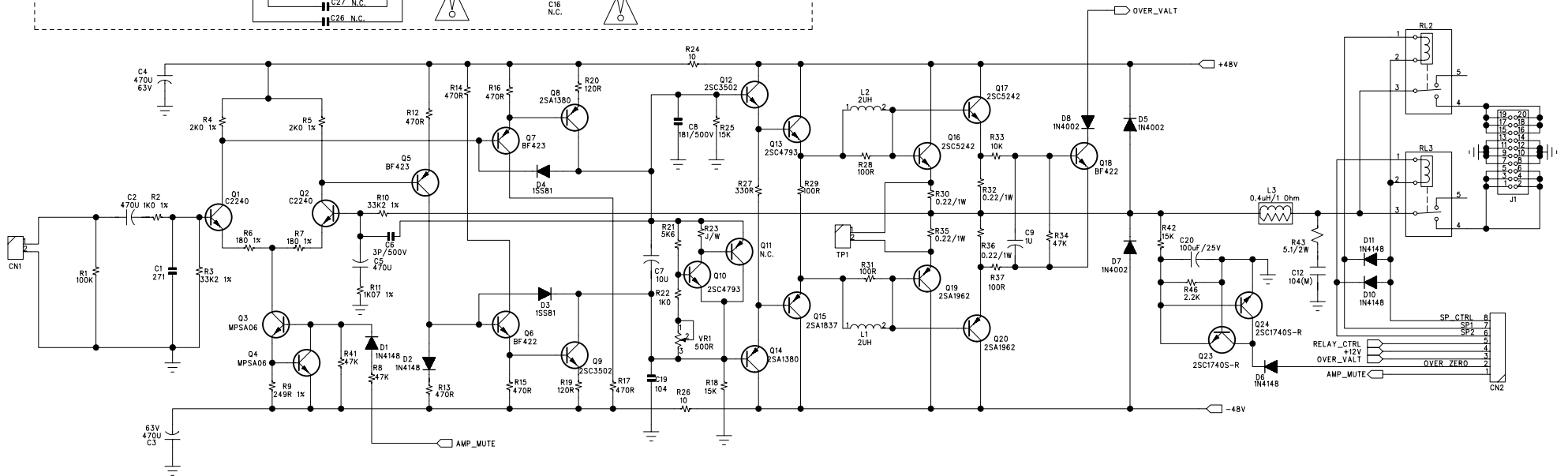
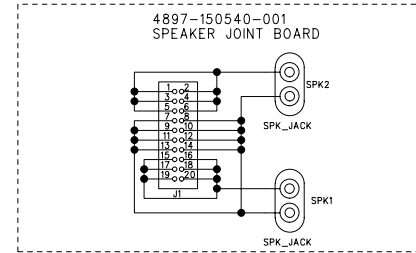
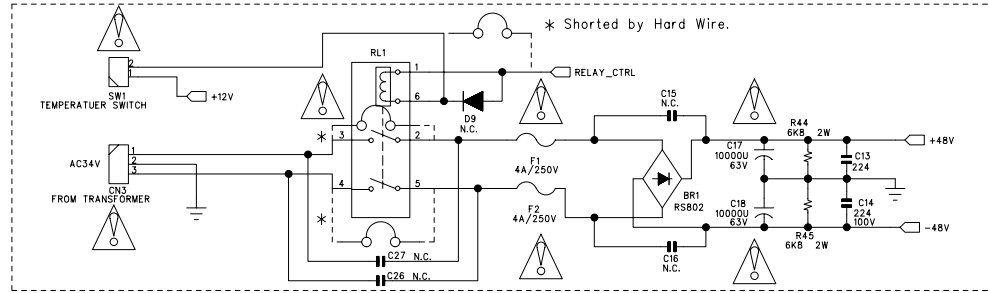

PURPOSE: SAMPLE MAKING	PRODUCTION	<input checked="" type="checkbox"/> SHEET 1 OF 1	REV A
PREPARED BY:	CHECKED BY:	APPROVED BY:	

YN

SCHEMATIC DRAWING
HKENF 970004-00

FILE NAME: RIGHTAMP_970.SCH
DATE: 2004-10-28

MODEL NO: HK970

PART NO: 4867-000090-001
4897-150540-001

PART NAME: RIGHT CHANNEL POWER AMPLIFIER
SPEAKER JOINT BOARD

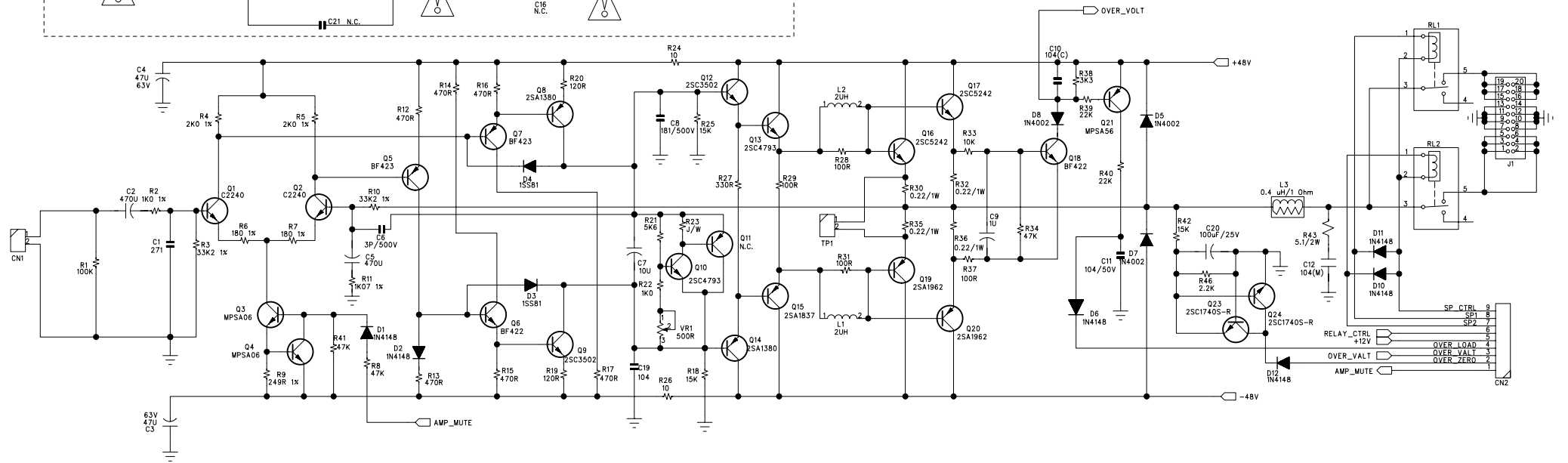
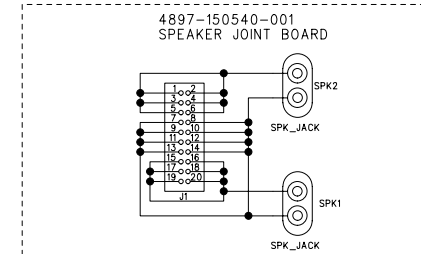
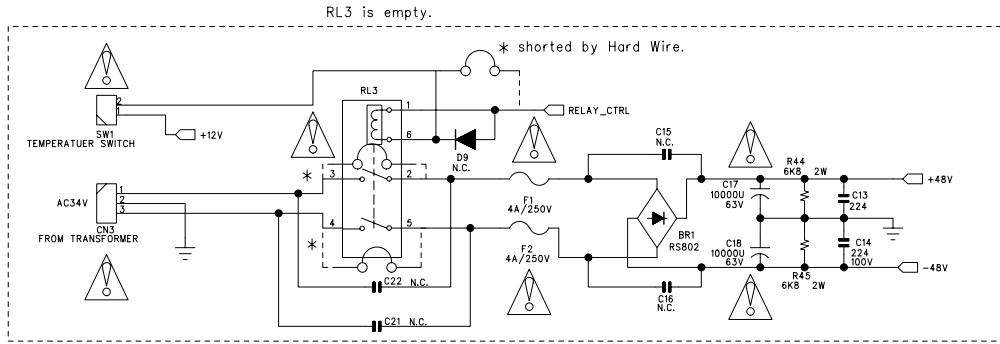

Remake:

YN		SCHMATIC DRAWING		FILE NAME: MCU_970_16.pcb
		HKENF YXXXXX-XX		DATE: 2005-JAN-05
MODEL NO: HK970	PART NO: 4897-150230-001, REV.F	PART NAME: HK970_MCU_VFD BOARD		

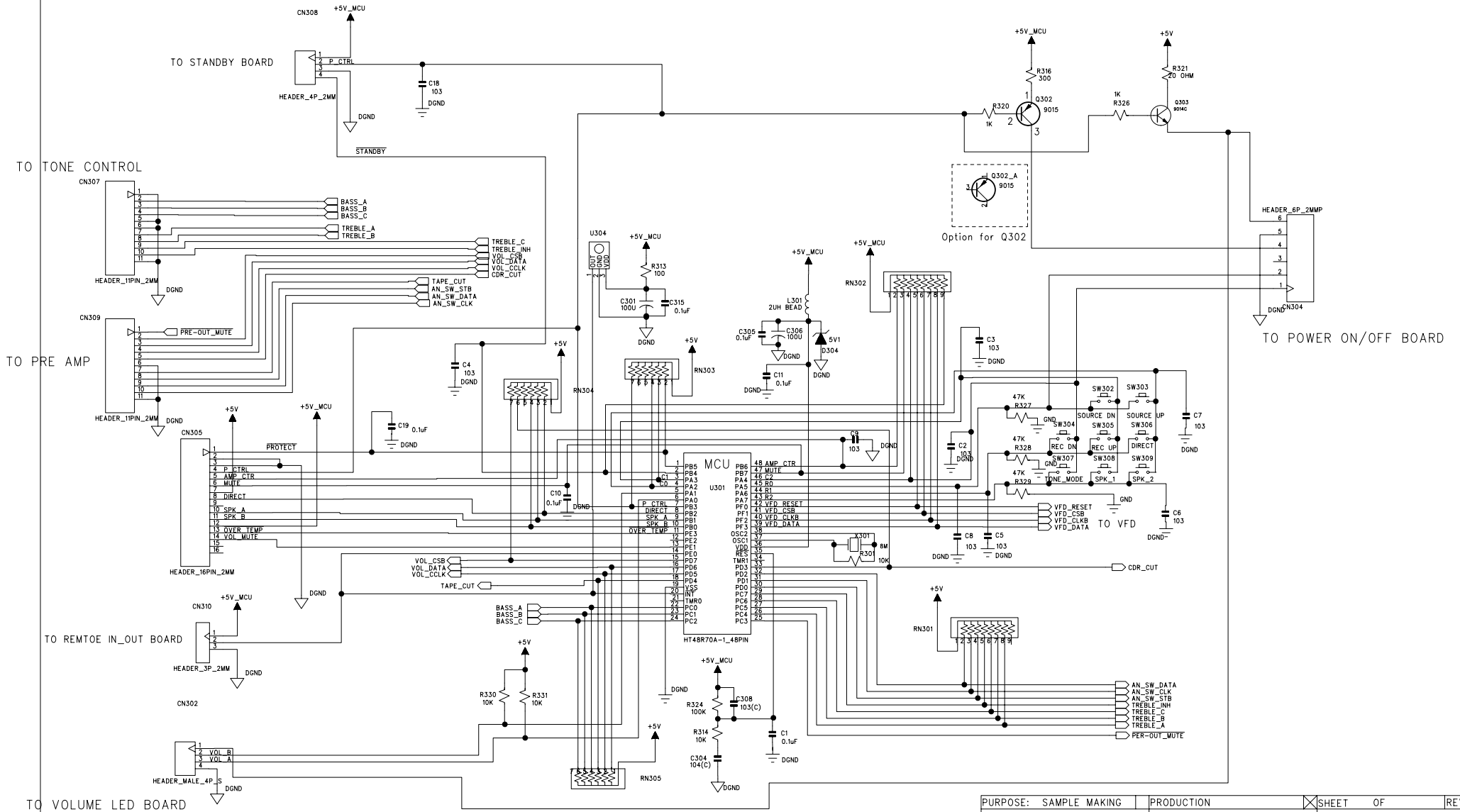

PURPOSE: SAMPLE MAKING	PRODUCTION	<input checked="" type="checkbox"/> SHEET	OF	REV
PREPARED BY:	CHECKED BY:	APPROVED BY:		

6

5

4

3

2

1

REVISION RECORD			
LTR	ECO NO:	APPROVED:	DATE:

REMARK:

Note: D303 can affect the brightness of VFD display. Zener voltage decrease, brightness increase.

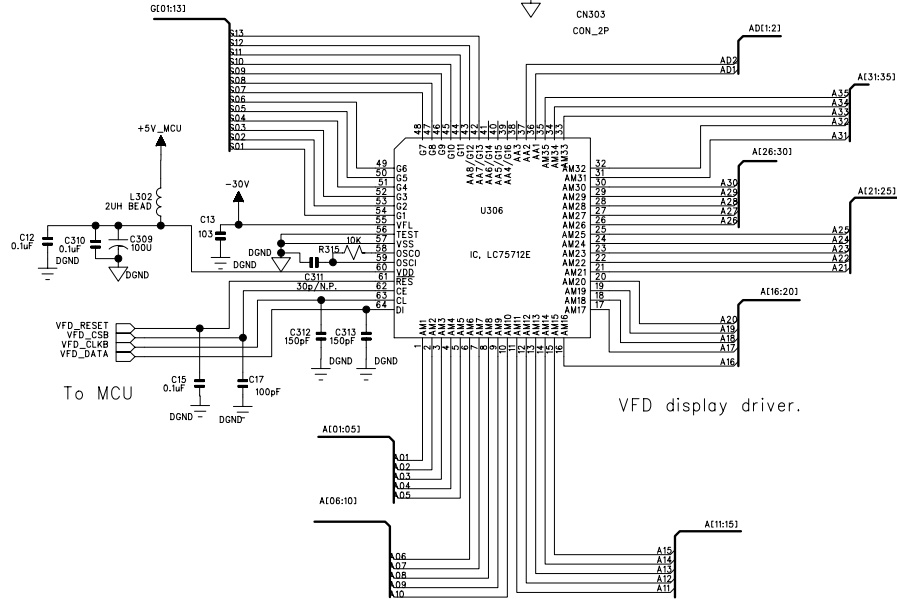
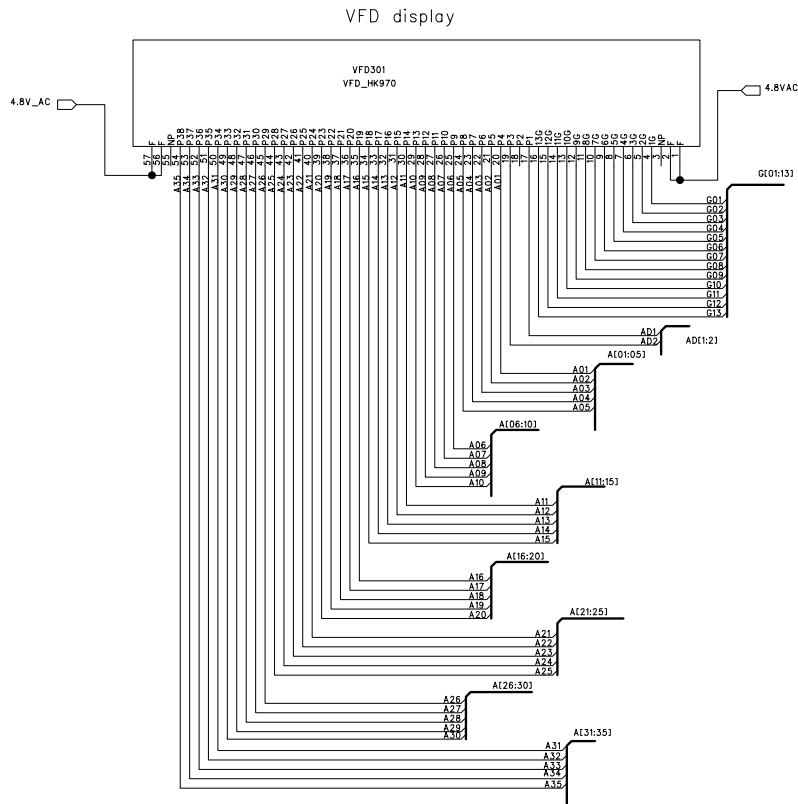
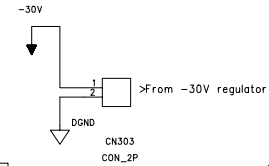
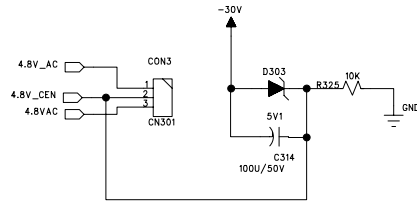

FILE NAME: MCU_970_16.sch

COMPANY:				
TITLE:				
HK970_MCU_VFD BOARD				
DRAWN:	DATED:	CODE:	SIZE:	DRAWING NO:
CHECKED:	DATED:	SCALE:	SHEET: OF	
QUALITY CONTROL:	DATED:	REV:		
RELEASED:	DATED:			

D

C

B

A

D

C

B

A

SCHEMATIC DRAWING

HKENF 970004-00

FILE NAME: SUPPLY_970_11.SCH

DATE: 2005-JAN-05

MODEL NO: HK970

PART NO:

PART NAME: POWER SUPPLY BOARD

SP_CTRL
SP1
SP2
RELAY_CTRL
+12V
PROTECT_OUT
OVER_LOAD
OVER_ZERO
AMP_MUTE

SP_CTRL
SP1
SP2
RELAY_CTRL
+12V
OVER_VALT
OVER_ZERO
AMP_MUTE

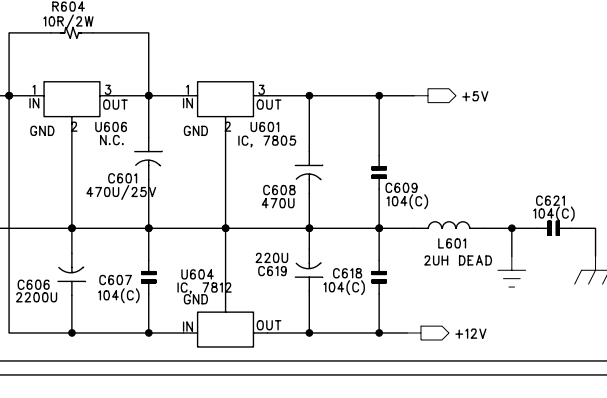
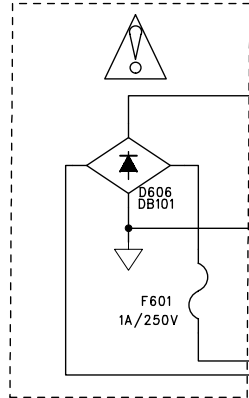

POWER SUPPLY BOARD
PCB: 4897-150070-001, REV.C

REMARK:

Speaker 1 on/off control part

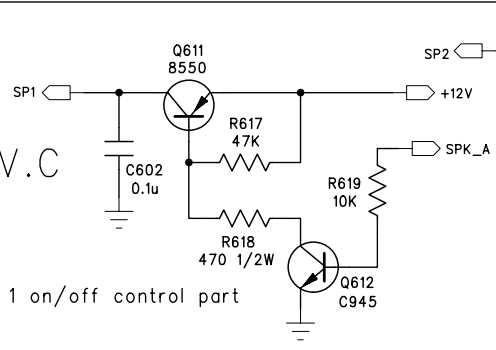

Speaker 2 on/off control part

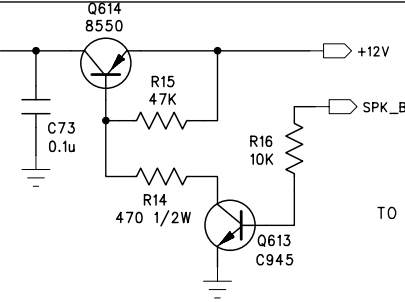

TO PRE AMP BOARD

HEADER_9PIN_2MMP

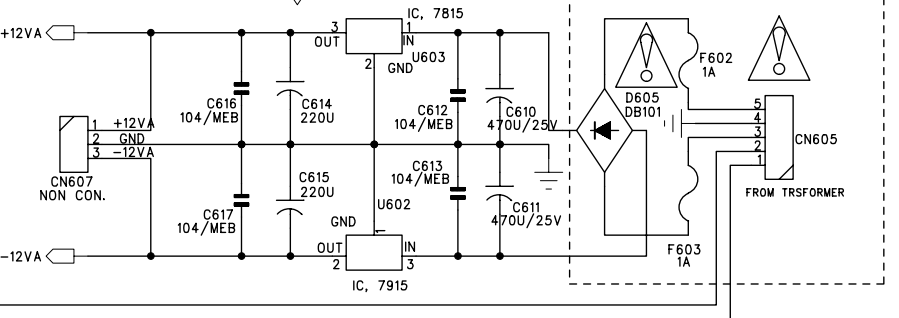
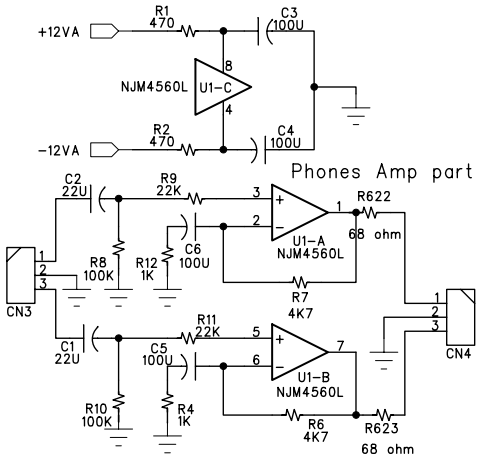

PURPOSE: SAMPLE MAKING	PRODUCTION	SHEET 1 OF 1	REV
PREPARED BY:	CHECKED BY:	APPROVED BY:	

6

5

4

3

2

1

D

C

B

A

REVISION RECORD			
LTR	ECO NO:	APPROVED:	DATE:

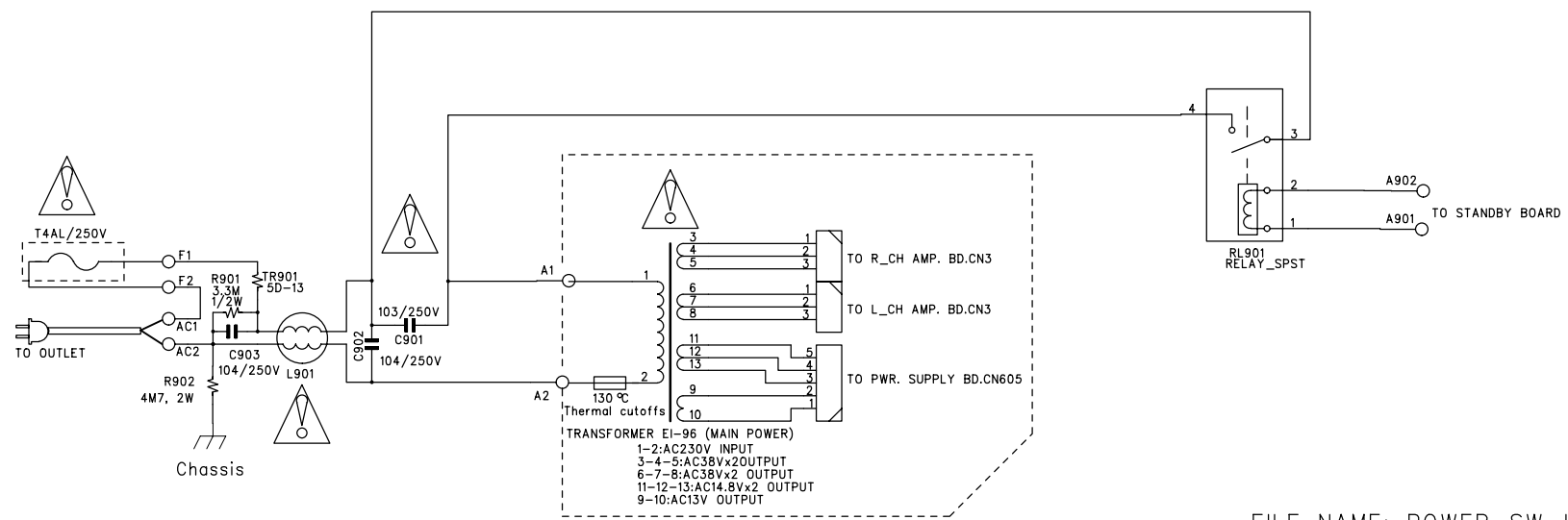

FILE NAME: POWER_SW_HK970_5.sch

REMARK:
 - ADD R902 FOR ESD PROPOSE

POWER SWITCH BOARD
 PCB: 4897-150070-101, REV.B

COMPANY:			
TITLE: HK970 POWER SWITCH			
DRAWN:	DATED: 2005-JAN-07	CODE:	SIZE:
CHECKED:	DATED:	DRAWING NO:	
QUALITY CONTROL:	DATED:	REV:	
RELEASED:	DATED:	SCALE:	SHEET: OF

Note: The reference code 7XX is same with TONE CONTROL BOARD

Remark:

SCHMATIC DRAWING

FILE NAME: pre_amp_970_6_HM_E.sch

HKENF xxxxxx-00

DATE: 2004-NOV-27

MODEL NO: HK970

PART NO: 4897-150330-001, Rev.F

PART NAME: HK970 PREAMP, ANALOG SWITCH.

PHONO PRE. AMPLIFIER

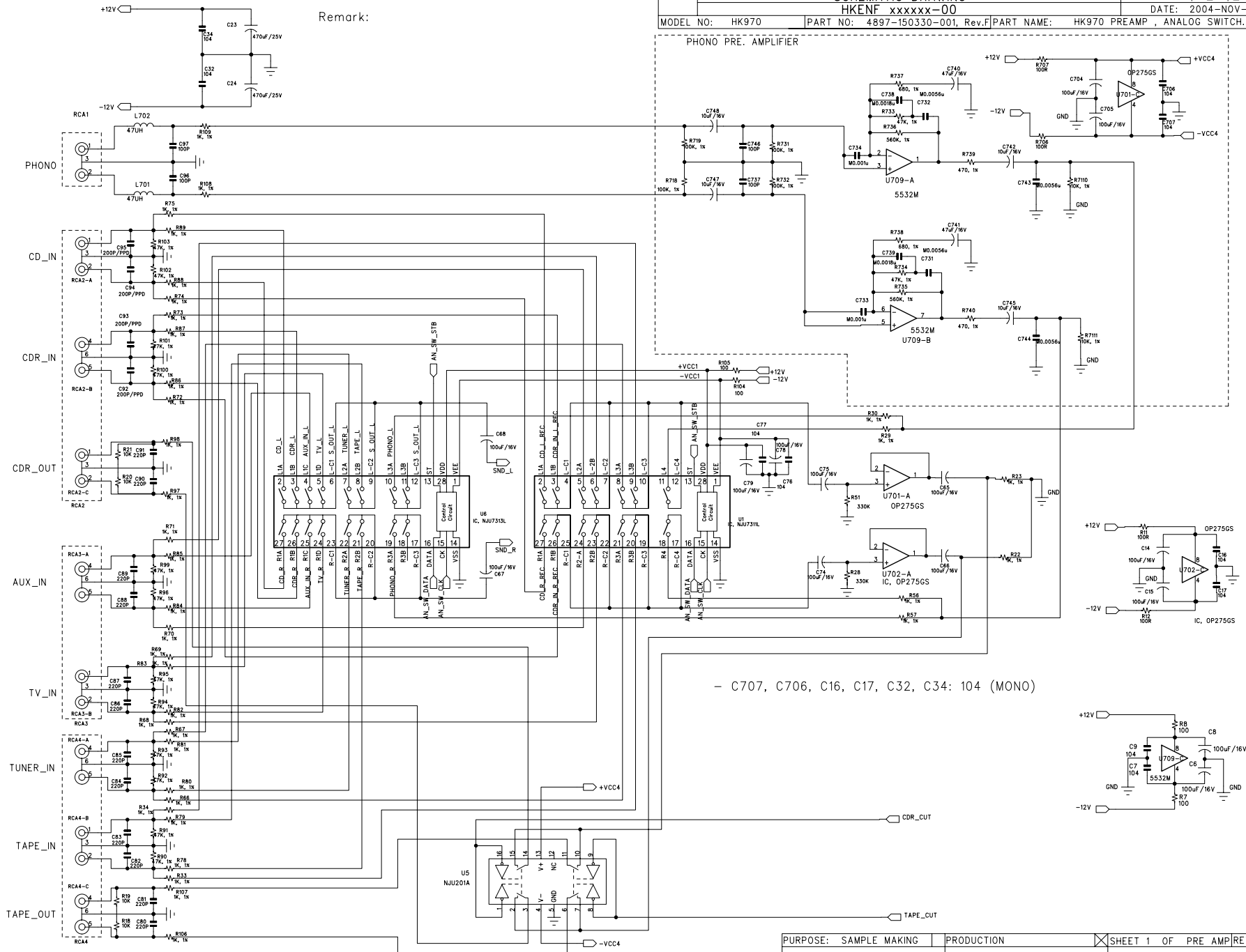

- C707, C706, C16, C17, C32, C34: 104 (MONO)

PURPOSE: SAMPLE MAKING	PRODUCTION	<input checked="" type="checkbox"/> SHEET 1 OF PRE AMP/REV
PREPARED BY:	CHECKED BY:	APPROVED BY:

6

5

4

3

2

1

soldering connection

Remark :

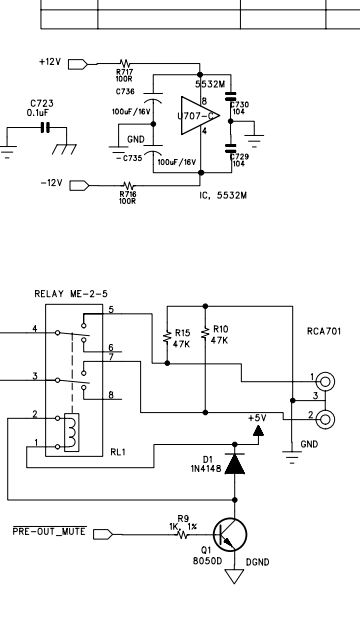
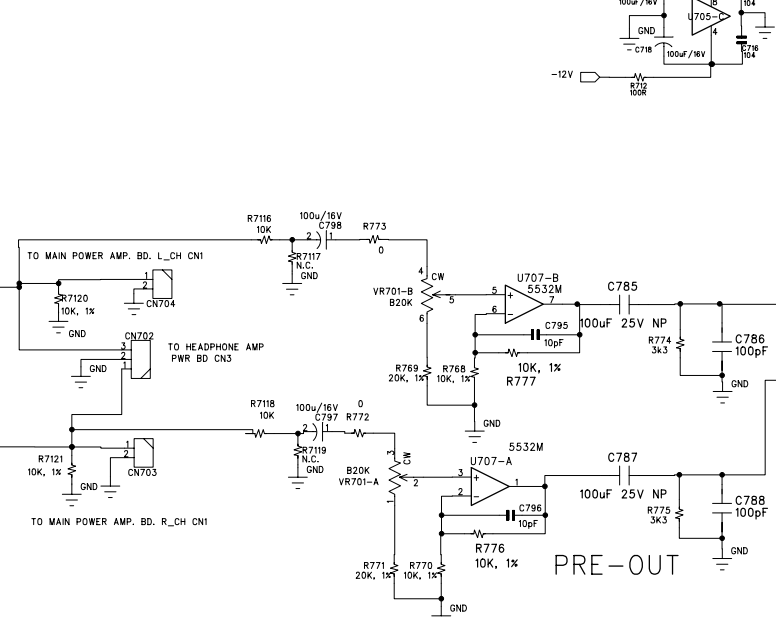
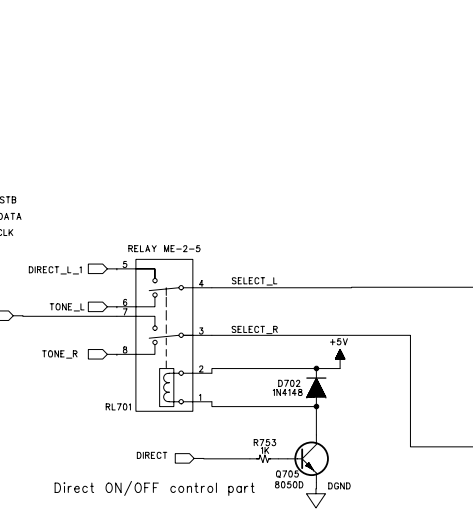
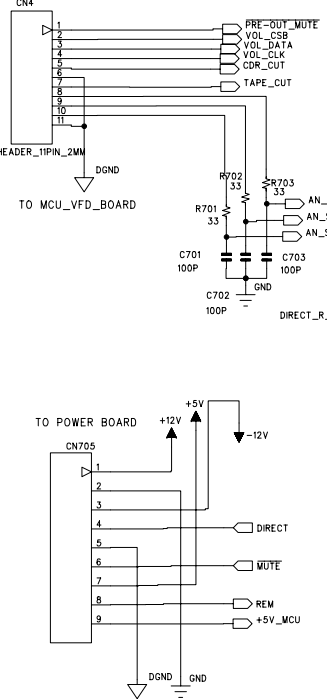

REVISION RECORD			
LTR	ECO NO:	APPROVED:	DATE:

D

D

C

C

B

B

A

A

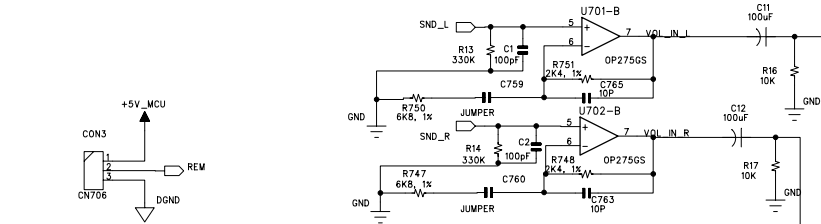

SND_L, SND_R: From Analog switch IC - U6,NJU7313.

TONE CONTROL: BASS:50HZ SINEWAVE FOR REFERENCE. TREBLE:10KHZ SINEWAVE FOR REFERENCE.

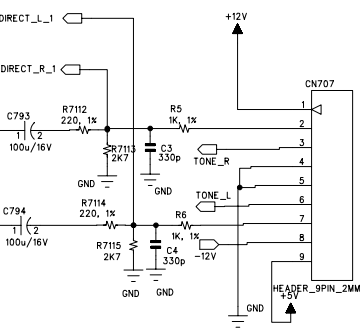
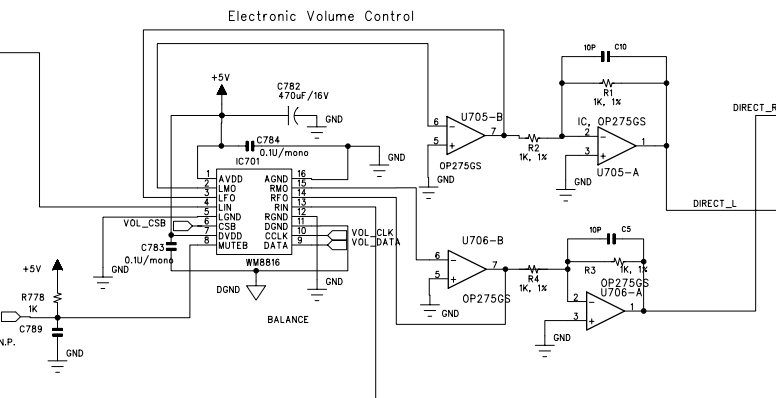

CN707 connect with TONE CONTROL Board

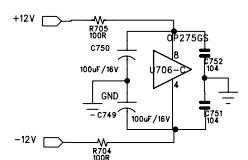

FILE NAME: PRE_AMP_970_6_HM_F.SCH
PCB: 4897-150330-001 REV.F

DRAWN:		DATED: 2004-NOV-27		COMPANY:	
CHECKED:		DATED:		TITLE: HK970 PRE AMP BOARD	
QUALITY CONTROL:		DATED:		CODE:	SIZE:
RELEASED:		DATED:		DRAWING NO:	REV:
SCALE:				SHEET: 2 OF PRE AMP	

SCHMATIC DRAWING

FILE NAME: REMOTE_IO_970_4.SCH

HKENF 970004-00

DATE: 2005-JAN-07

MODEL NO: HK970

PART NO:

PART NAME: REMOTE IN / OUT BOARD

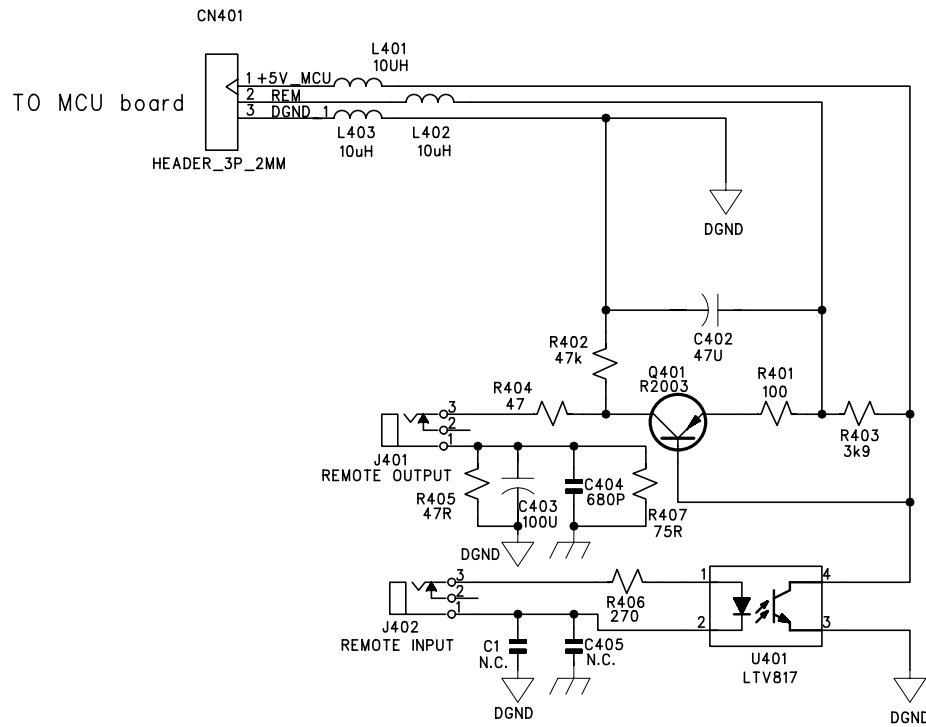

REMARK:

PCB: 4897-150080-001, Rev.B

PURPOSE: SAMPLE MAKING	PRODUCTION	<input checked="" type="checkbox"/> SHEET 1 OF 1
PREPARED BY:	CHECKED BY:	APPROVED BY:

6

5

4

3

2

1

REVISION RECORD			
LTR	ECO NO:	APPROVED:	DATE:

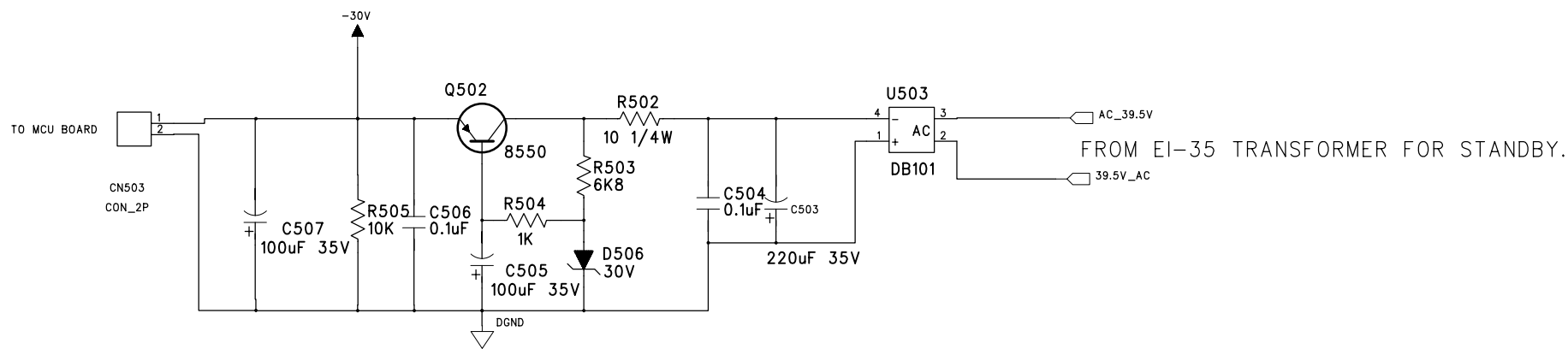

FROM EI-35 TRANSFORMER FOR STANDBY.

-30 V REGULATING FOR VFD

File: standby_board_970_13.sch

REMARK

- POWER IS -30V
- CHANGE VOLTAGE OF C507, C505 TO 35V

PCB: 4897-150110-001

COMPANY:			
TITLE: HK970 STANDBY POWER BOARD			
CODE:	SIZE:	DRAWING NO:	REV:
SCALE:		SHEET: OF	

DRAWN:	DATED: 11-DEC-04
CHECKED:	DATED:
QUALITY CONTROL:	DATED:
RELEASED:	DATED:

6

5

4

3

2

1

REMARK:

REVISION RECORD			
LTR	ECO NO:	APPROVED:	DATE:

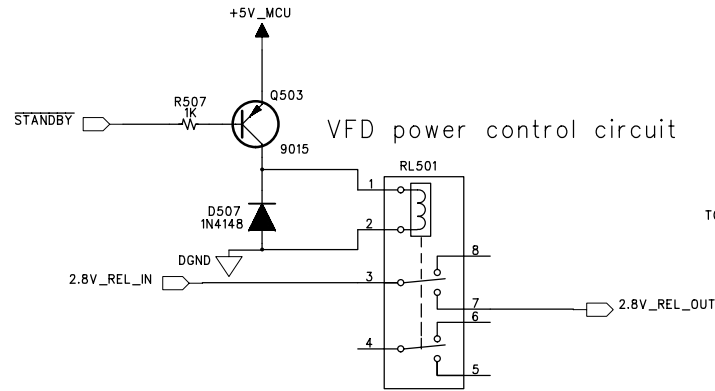

Primary power control circuit

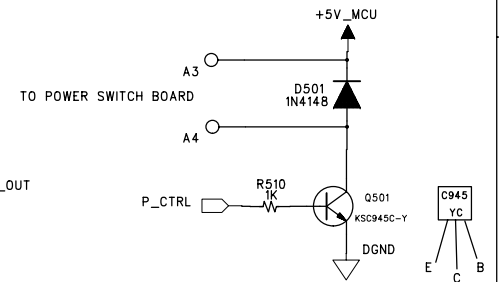

1-2: INPUT AC230V
 OUTPUT
 3-4: AC10V
 8-9: AC23V
 5-6-7: AC4.8V x 2

>From AC Supply

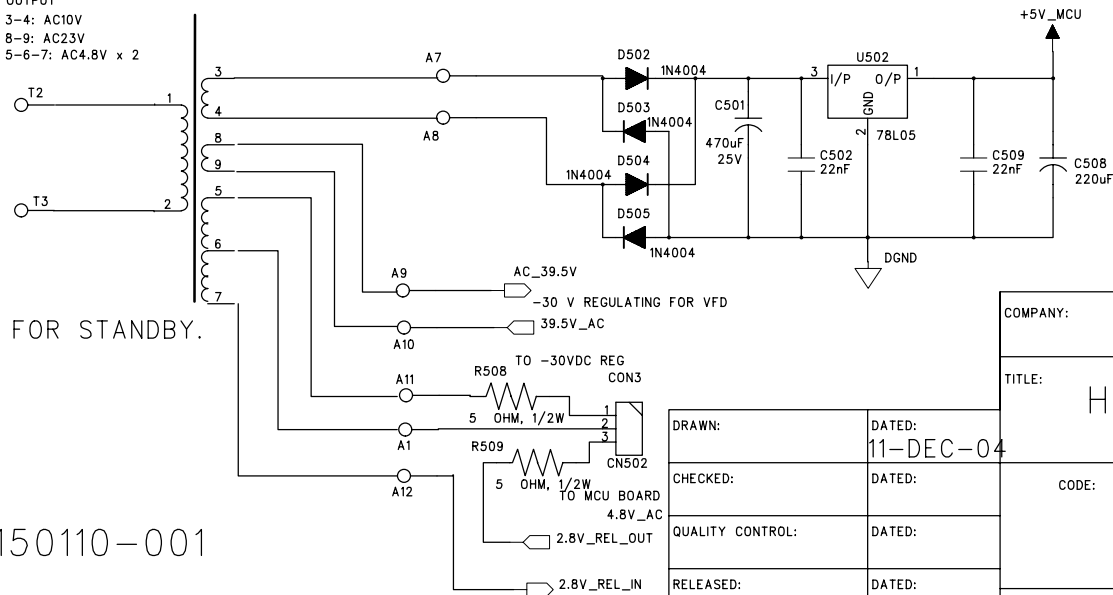

FILE: standby_board_970_13.sch

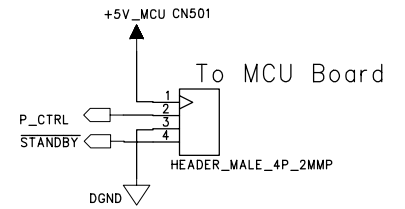

EI-35 TRANSFORMER FOR STANDBY.

PCB: 4897-150110-001

COMPANY:

TITLE:

HK970 Standby Power Board

DRAWN:	DATED:
CHECKED:	DATED:
QUALITY CONTROL:	DATED:
RELEASED:	DATED:

CODE:	SIZE:	DRAWING NO:	REV:
SCALE:	SHEET:		OF

6

5

4

3

2

1

REVISION RECORD			
LTR	ECO NO:	APPROVED:	DATE:

D

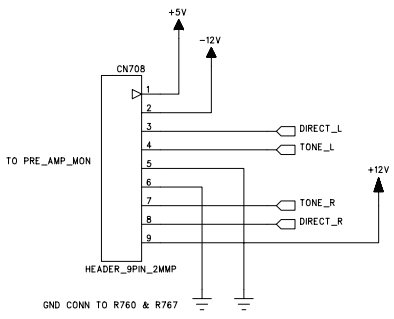

C

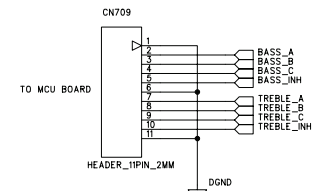

B

REMARK:

A

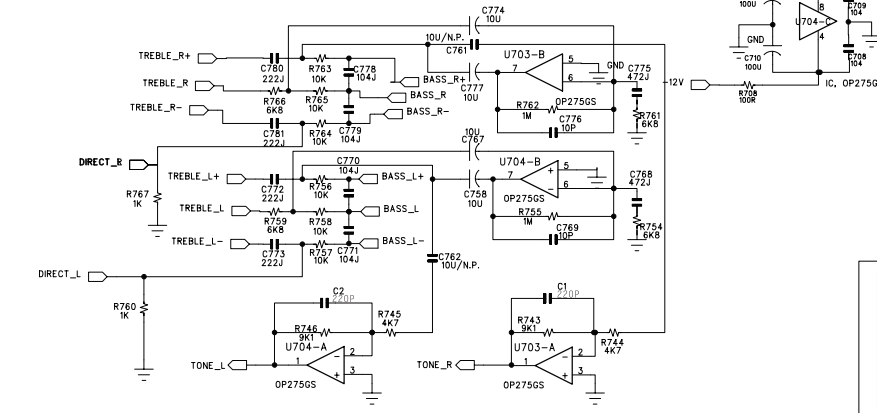

Treble Level Selection of Right channel.

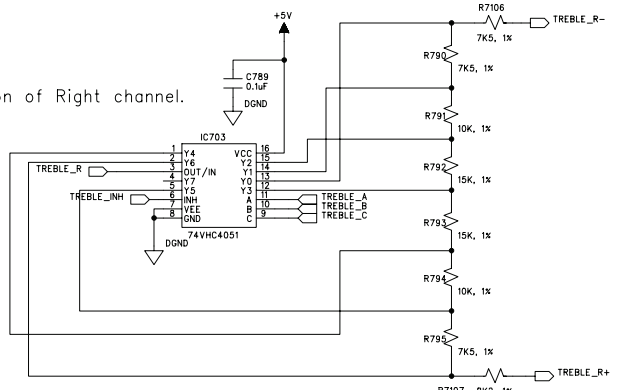

Treble Level Selection of Left channel.

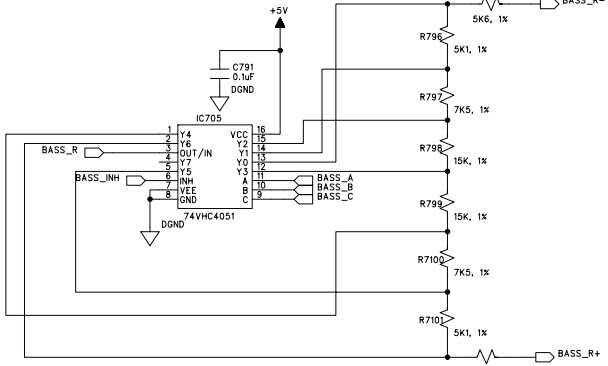
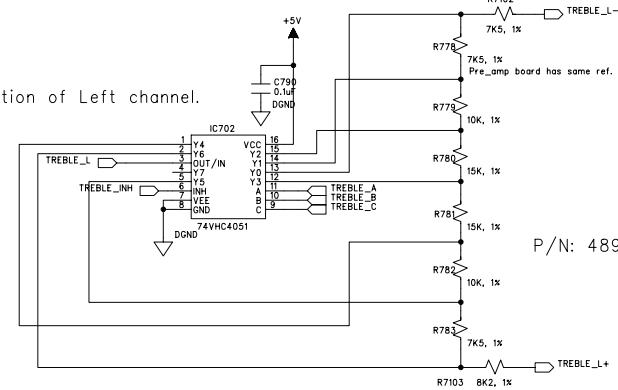

Bass Level Selection of Right channel.

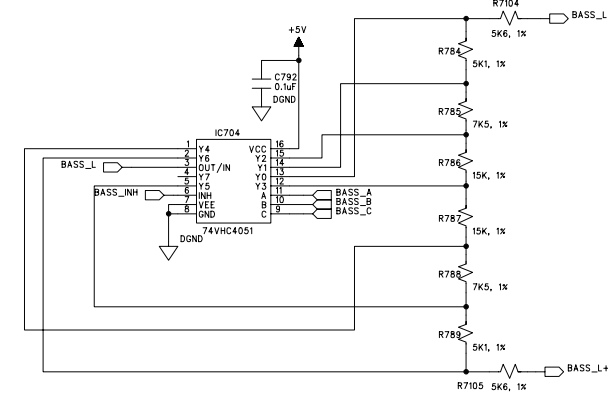

Bass Level Selection of Left channel.

FILE NAME: TONE_CONTROL_970_18.SCH

P/N: 4897-150560-001, Rev.F

DRAWN:	DATED:
CHECKED:	DATED:
QUALITY CONTROL:	DATED:
RELEASED:	DATED:

COMPANY:			
TITLE:			
HK970 TONE CONTROL BOARD			
CODE:	SIZE:	DRAWING NO:	REV:
SCALE:	SHEET: OF		

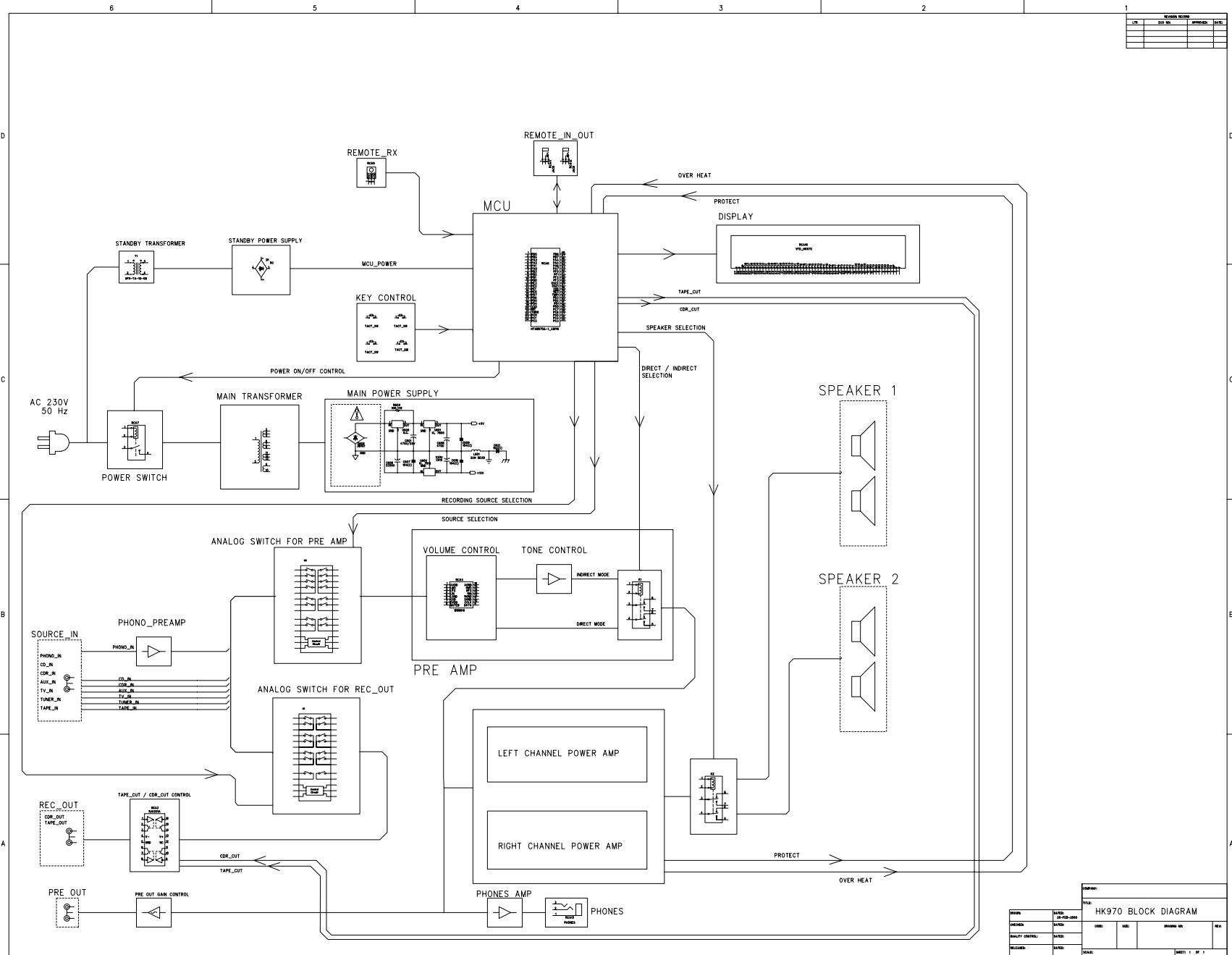

REVISION RECORD			
NO.	REV. NO.	APPROVED	DATE

PARTS				DATE			
DESIGNER				BY			
CHECKED				DATE			
DRAWN				SCALE			
TITLE				SHEET			
NO.				OF			

PART: HK970 BLOCK DIAGRAM
 DATE: 2000-08-10
 BY: []
 CHECKED: []
 DATE: []
 DRAWN: []
 SCALE: []
 SHEET: 1 OF 1

6 5 4 3 2 1

REVISION RECORD			
LTN	ECO NO.	APPROVED	DATE

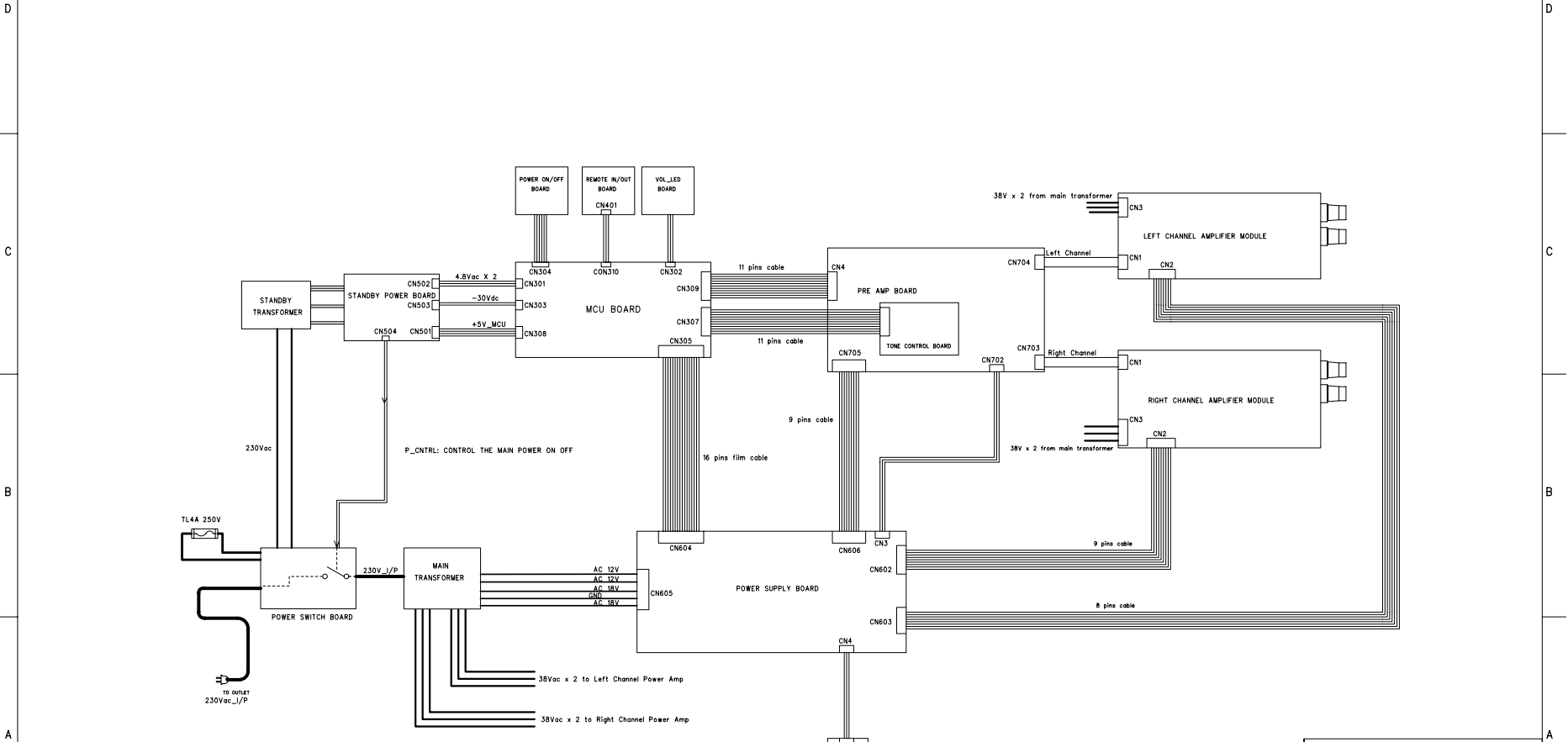

DRAWN		DATE: 21-FEB-05		COMPANY:	
CHECKED:		DATE:		TITLE: HK970 WIRING BOARD	
QUALITY CONTROL:		DATE:		CODE:	SIZE:
RELEASED:		DATE:		DRAWING NO.:	REV.:
SCALE:				SHEET: 1 OF 1	

■ PIN CONFIGURATION

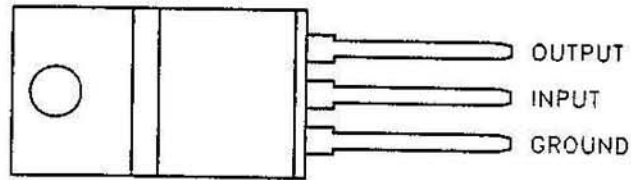
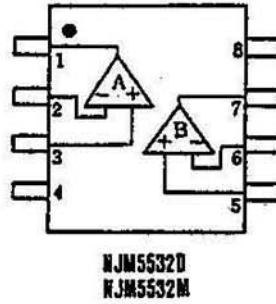

L7805CV LM7815 CS12790
NJM7812FA LM7915 TO-220FP

■ PIN CONFIGURATION

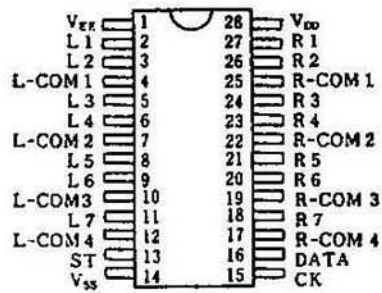

NJU7311AL

Pinouts

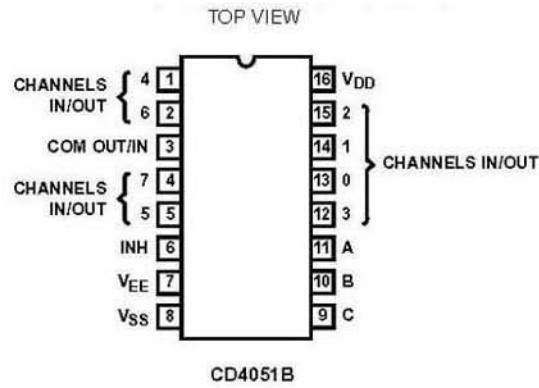

8-Lead Narrow-Body SOIC (S Suffix)

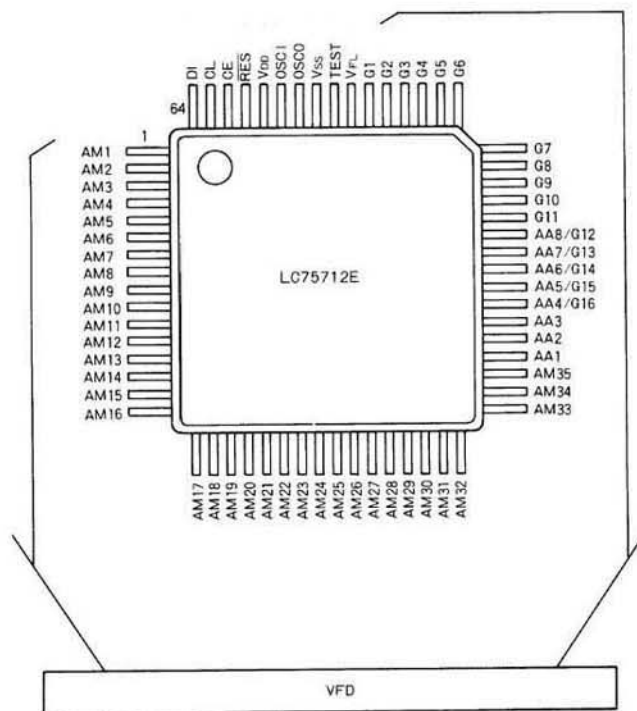
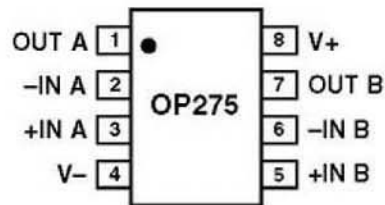

LM78L05

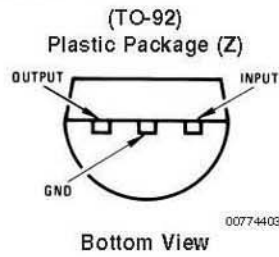

Pin No. and internal connection diagram

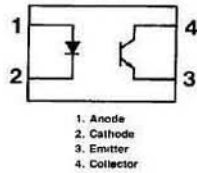

LTV817
Pin Configuration

Pin Assignment

PB5	1	48	PB6
PB4	2	47	PB7
PA3	3	46	PA4
PA2	4	45	PA5
PA1	5	44	PA6
PA0	6	43	PA7
PB3	7	42	PF0
PB2	8	41	PF1
PB1	9	40	PF2
PB0	10	39	PF3
PE3	11	38	OSC2
PE2	12	37	OSC1
PE1	13	36	VDD
PE0	14	35	RES
PD7	15	34	TMR1
PD6	16	33	PD3
PD5	17	32	PD2
PD4	18	31	PD1
VSS	19	30	PD0
INT	20	29	PC7
TMR0	21	28	PC6
PC0	22	27	PC5
PC1	23	26	PC4
PC2	24	25	PC3

HT48R70A-1
- 48 SSOP-A

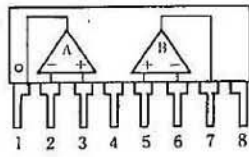

NJM4560L

PIN FUNCTION

- 1. A OUTPUT
- 2. A-INPUT
- 3. A+INPUT
- 4. V⁻
- 5. B+INPUT
- 6. B-INPUT
- 7. B OUTPUT
- 8. V⁺

■ **PIN CONFIGURATION**

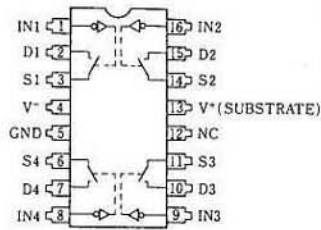

NJU201AM

PIN CONFIGURATION

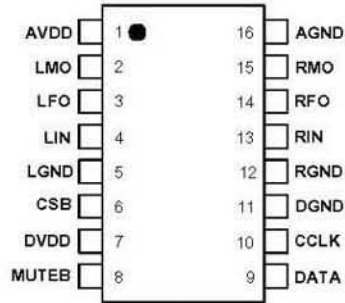

WM8816

■ **PIN CONFIGURATION**

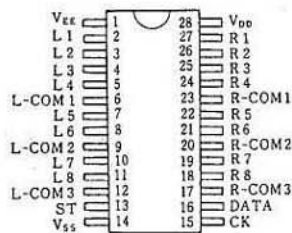

NJU7313AL

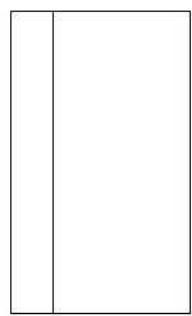
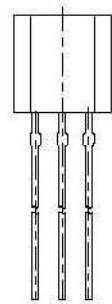

9014C.....	E B C
9015C.....	E B C
2SB737Q.....	E C B
KSC945C-Y.....	E C B
SS8550C.....	E B C
FJN3303R.....	E C B
KSR2003.....	E C B
MPSA06.....	E B C
2SC1740.....	B C E
2SC2240-GR.....	E C B
BF422.....	E C B
MPSA56.....	E C B
8050D.....	E B C
BF423.....	E C B

Unit in mm

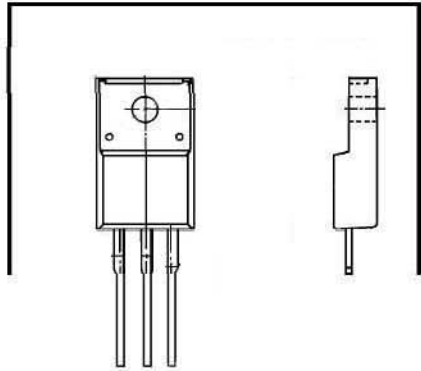

2SC3502.....	B C E
2SC4793.....	E C B
2SC5242-0.....	E C B
2SA1380.....	B C E
2CA1837.....	B C E
2SA1962-0.....	E C B

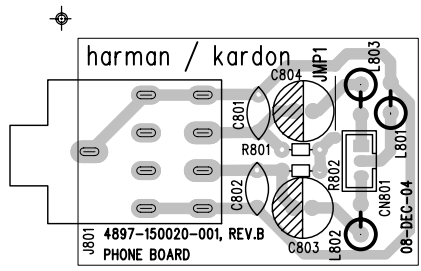

HEADPHONE BOARD
 - SINGLE LAYER BOARD
 - COMPONENT SIDE

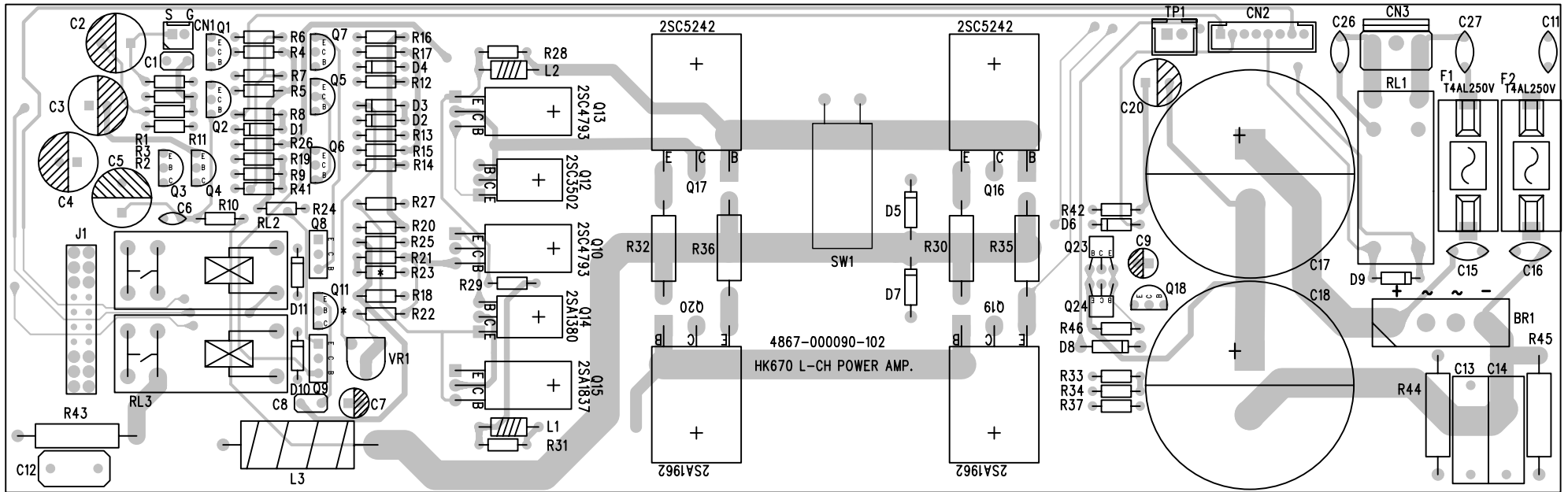

LEFT CHANNEL AMPLIFIER BOARD (LAYER TOP)
 - DOUBLE LAYER BOARD

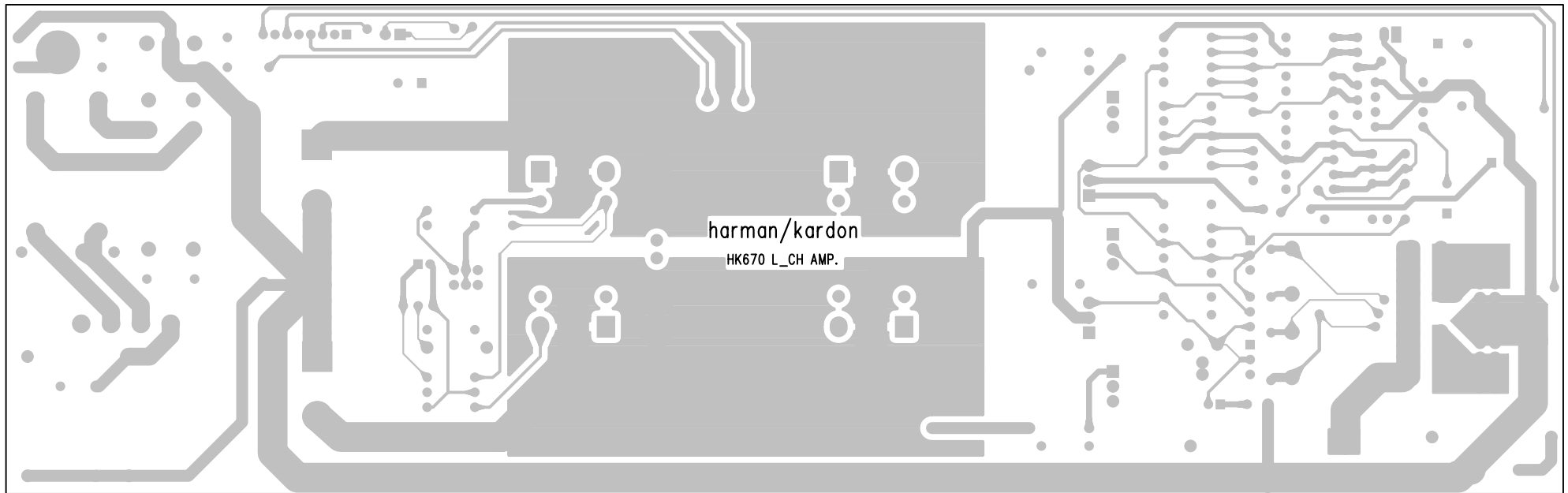

LEFT CHANNEL AMPLIFIER BOARD (LAYER BOTTOM)
- DOUBLE LAYER BOARD

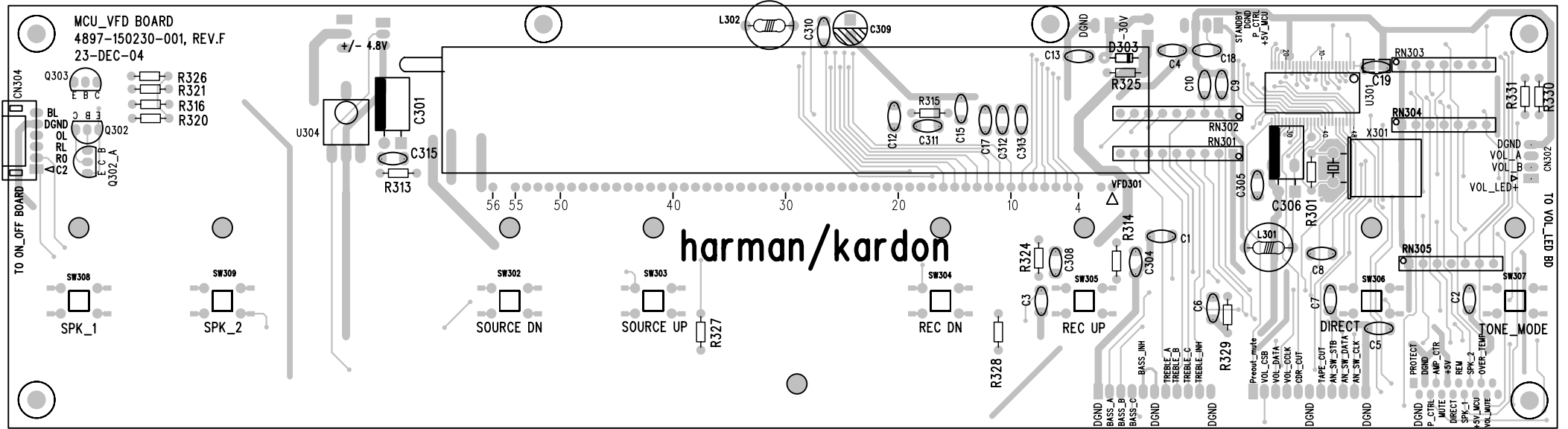

MCU BOARD (LAYER TOP)
- DOUBLE LAYER BOARD

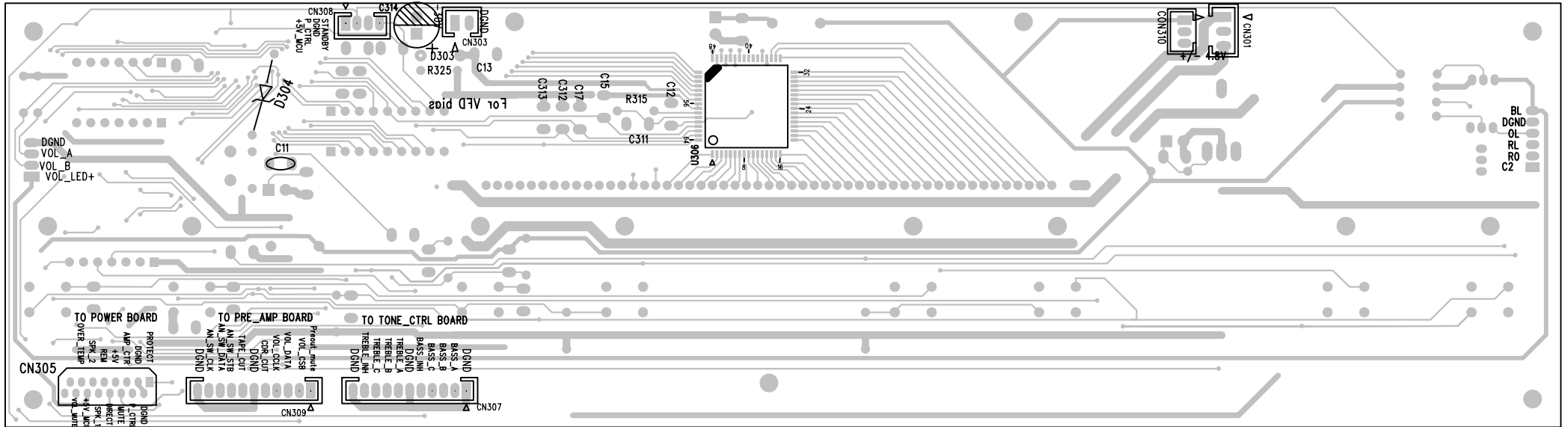

MCU BOARD (LAYER BOTTOM)
 – DOUBLE LAYER BOARD

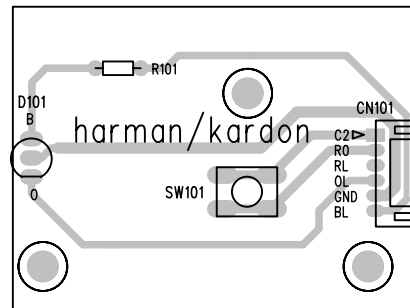

POWER ON/OFF BOARD
- SINGLE LAYER BOARD
- COMPONENT SIDE

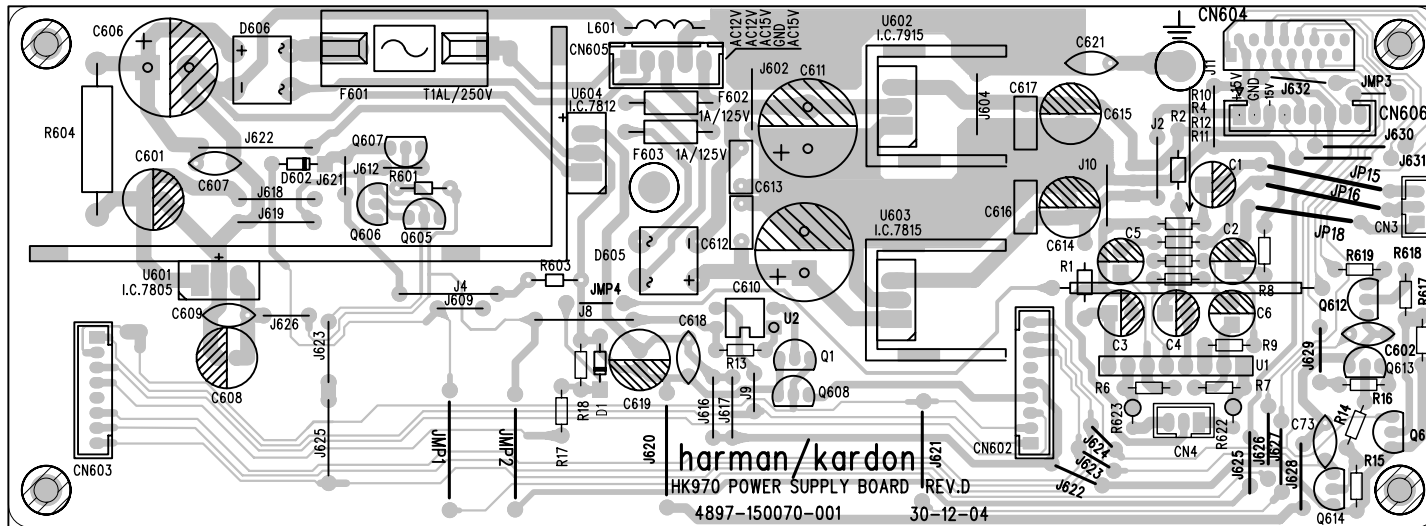

POWER SUPPLY BOARD
 - SINGLE LAYOUT BOARD
 - COMPONENT SIDE

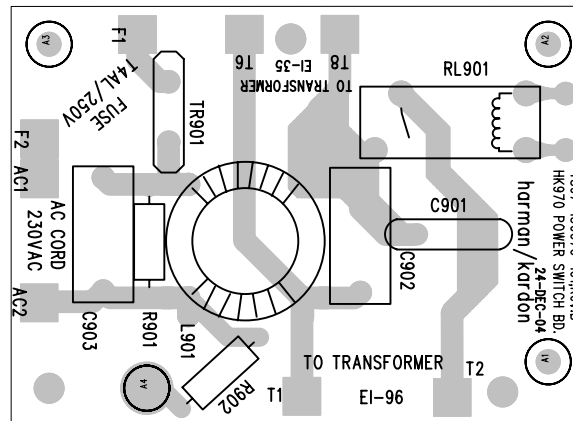

POWER SWITCH BOARD
 - SINGLE LAYER BOARD
 - COMPONENT SIDE

PRE AMPLIFIER BOARD (LAYER TOP) - DOUBLE LAYER BOARD

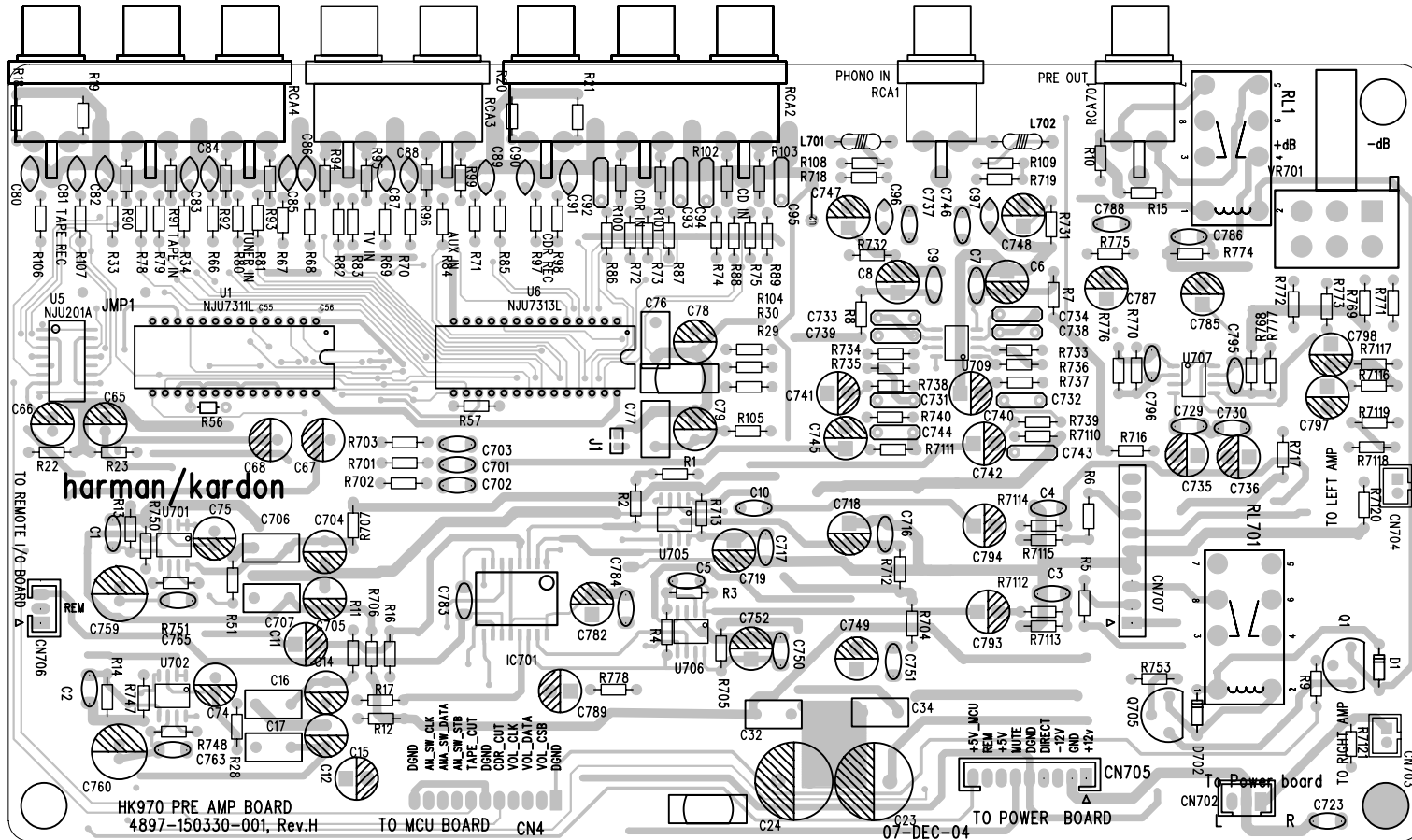

PRE AMPLIFIER BOARD (LAYER BOTTOM)
- DOUBLE LAYER BOARD

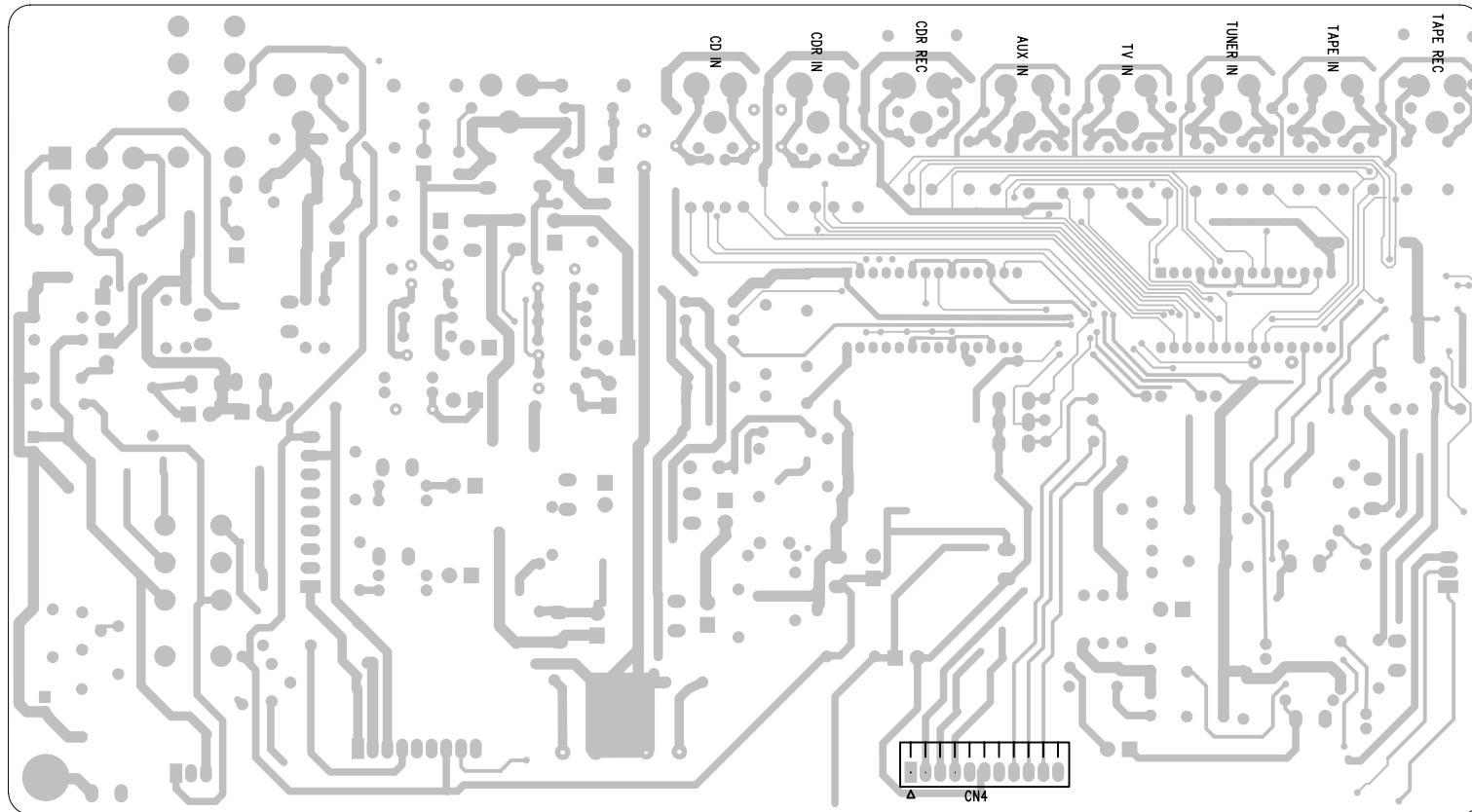

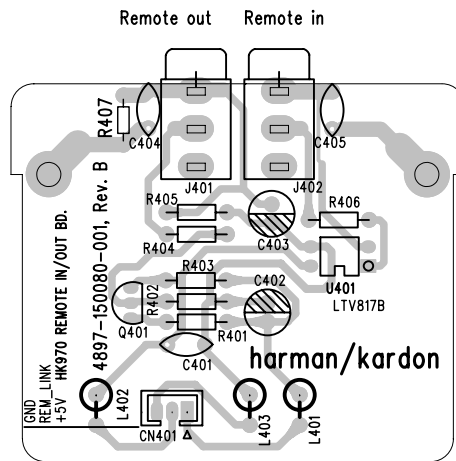

REMOTE IN/OUT BOARD
 - SINGLE LAYER BOARD
 - COMPONENT SIDE

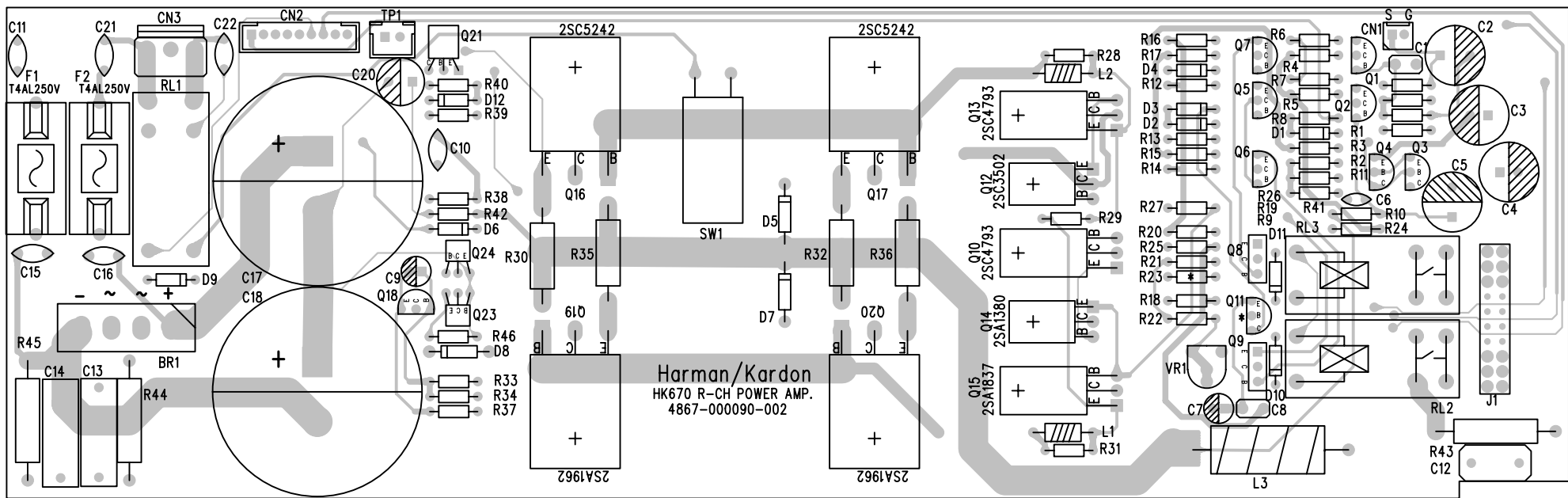

RIGHT CHANNEL AMPLIFIER BOARD (TOP LAYER)
- DOUBLE LAYER BOARD

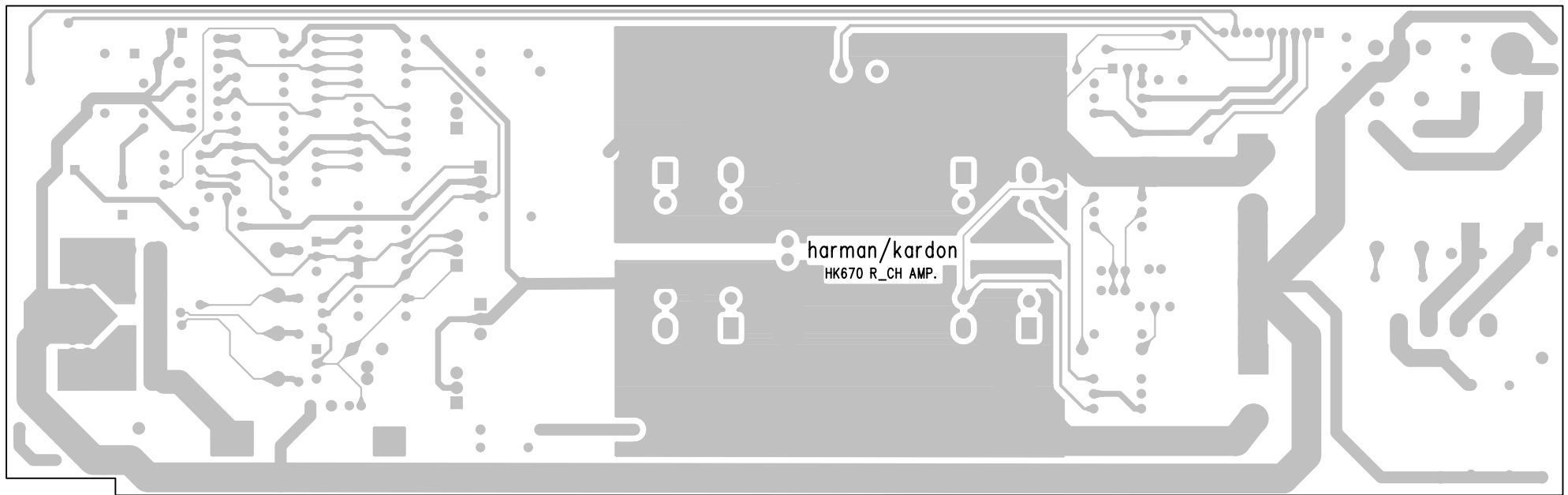

RIGHT CHANNEL AMPLIFIER BOARD (BOTTOM LAYER)
- DOUBLE LAYER BOARD

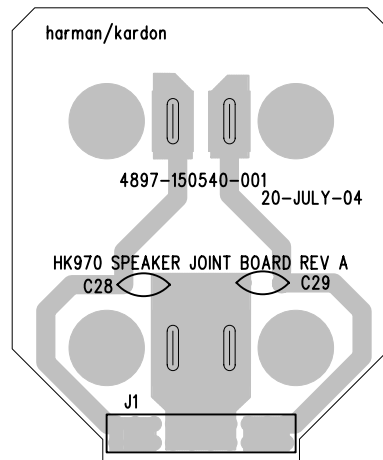

SPEAKER JOINT BOARD (TOP LAYER)
- DOUBLE LAYER BOARD

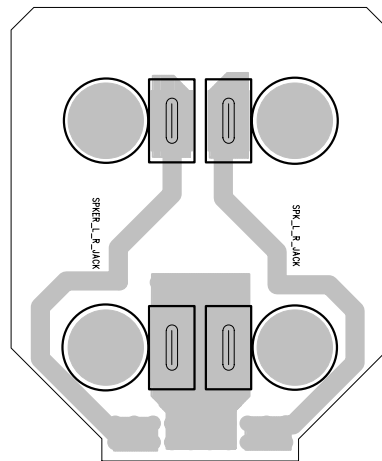

SPEAKER JOINT BOARD (BOTTOM LAYER)
– DOUBLE LAYER BOARD

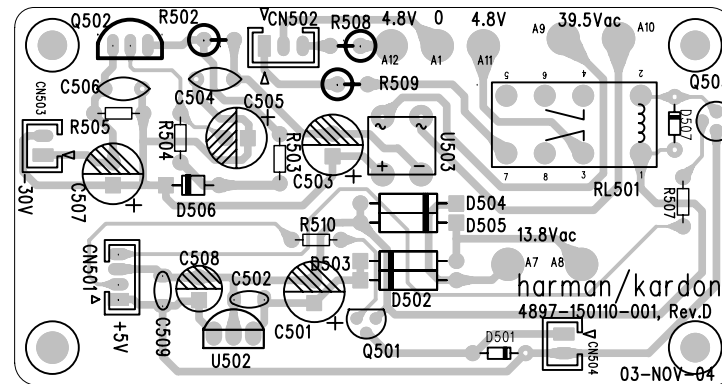

STANDBY POWER BOARD
 - SINGLE LAYER BOARD
 - COMPONENT SIDE

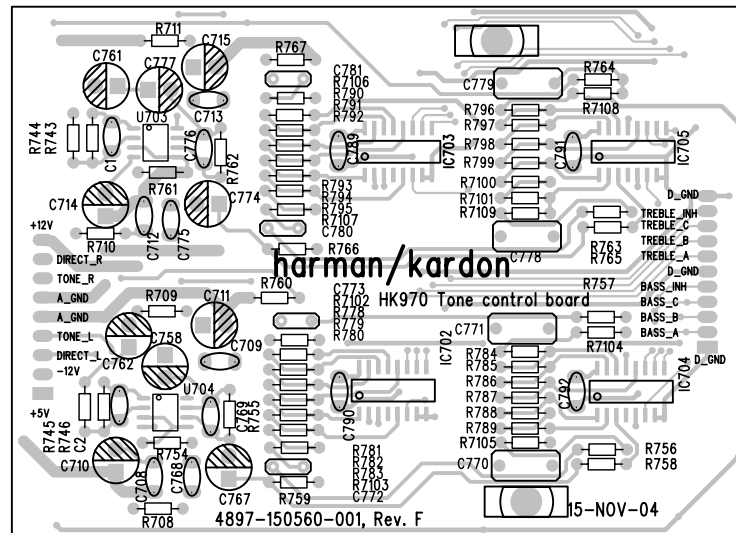

TONE CONTROL BOARD (LAYOUT TOP)
- DOUBLE LAYER BOARD

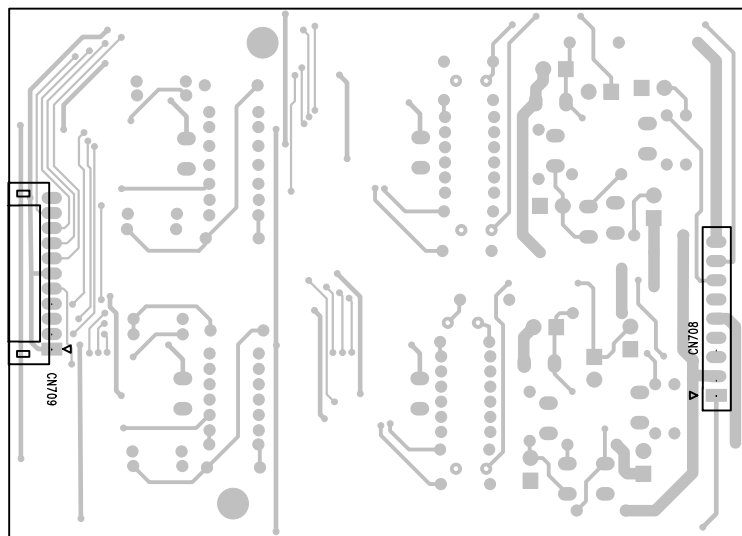

TONE CONTROL BOARD (LAYOUT BOTTOM)
- DOUBLE LAYER BOARD

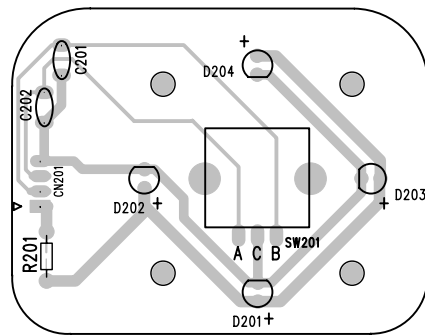

VOL_LED BOARD
- SINGLE LAYER BOARD
- COMPONENT SIDE

65	8597-015010-300	PLASTIC FOOT ASSY FOR HK970	4
64	7004-010010-111	SCREW M4X10 M/C TYPE B/H BLACK	4
63	7003-014010-111	SCREW M3X14 M/C TYPE B/H BLK	2
62	7003-008001-111	SCREW M3X8 S.T.O. B/H BLK	8
39	8597-015020-300	LENS ASSY FOR HK970	1
38	7003-006002-111	SCREW M3X6 P.T.P. B/H (BLACK)	2
37	8597-015000-100	HK970 VOLUME KNOB ASSY	1
36	8597-015000-300	HK970 FRONT PANEL ASSY	1
35	8597-015010-601	HK970 BOTTOM CABINET ASSY WITH PAINTED	1
34	6600-240036-000	HK970 INSULATION SHEET-4	1
33	6600-220030-000	BMM NYLON STANDOFF SCF-8 BLACK	4
32	6597-150004-000	SHIELDING PLATE	1
31	9497-015001-071	HK970 POWER SWITCH BOARD ASSY	1
30	6600-105001-000	HEAT SHRINK TUBE 50MM DIA L=95MM	1
29	3200-729201-000	TX 230V135 DCBVO.2A AC2.8V0.15A	1
28	9497-015000-111	HK970 STANDBY POWER BOARD ASSY	1
27	8600-120030-001	NUT M3 HEX M3X5.5X2.4MM	2
26	7103-706504-162	EXTERNAL TOOTH LOCK WASHER, 3.7X6.5X0.4MM	2
25	7103-706710-022	METAL WASHER M3.7X6.7X1	2
24	9497-015001-091	HK970 LEFT CHANNEL POWER AMP	1
23	6597-150002-000	HK970 METAL TOP-COVER W/COLOR	1
22	7003-006001-063	SCREW M3X6 S.T.P. W/H NI-PLATED	6
21	7003-006010-111	SCREW M3X6 M.C. B/H BLK	12
20	6600-120040-000	SCREW NUT M4X7X3	4
19	7104-308504-162	ETW M4	4
18	7104-010010-022	WASHER M4X10X1MM	4
17	3200-307541-400	TRANSFORMER 230V VDE	1
16	9497-015000-091	HK970 RIGHT CHANNEL POWER AMP	1
15	6600-210245-000	EVA PAD 20*12*10.5	3
14	9497-015000-071	HK970 POWER SUPPLY BOARD ASSY	1
13	6600-210245-000	EVA PAD 20*12*13.5	3
12	9497-015000-331	HK970 PRE AMP BOARD ASSY	1
11	9497-015000-081	HK970 REMOTE IN/OUT BOARD ASSY	1
10	6567-150007-000	HK670 PCB BRACKET	2
9	6597-150010-000	SCREW M3X8 P.T.P. B/H (BLACK)	1
8	7003-008002-111	SCREW M3X8 P.T.P. B/H (BLACK)	4
7	6600-990023-000	GROUND TERMINAL	1
6	7003-006001-113	SCREW M3X6 S.T.P. B/H NI-PLATED	11
5	7003-010002-111	SCREW M3X10 P TYPE B/H BLK	15
4	7003-006001-111	SCREW M3X6 S.T.P. B/H (BLACK)	36
3	4031-000002-000	PUSH HOLDER	1
2	6600-180017-000	AC CORD BUSHING	1
1	2610-220009-004	2000MM AC CORD VDE	1
NO	PARTS NO.	DESCRIPTION	QTY REMARKS

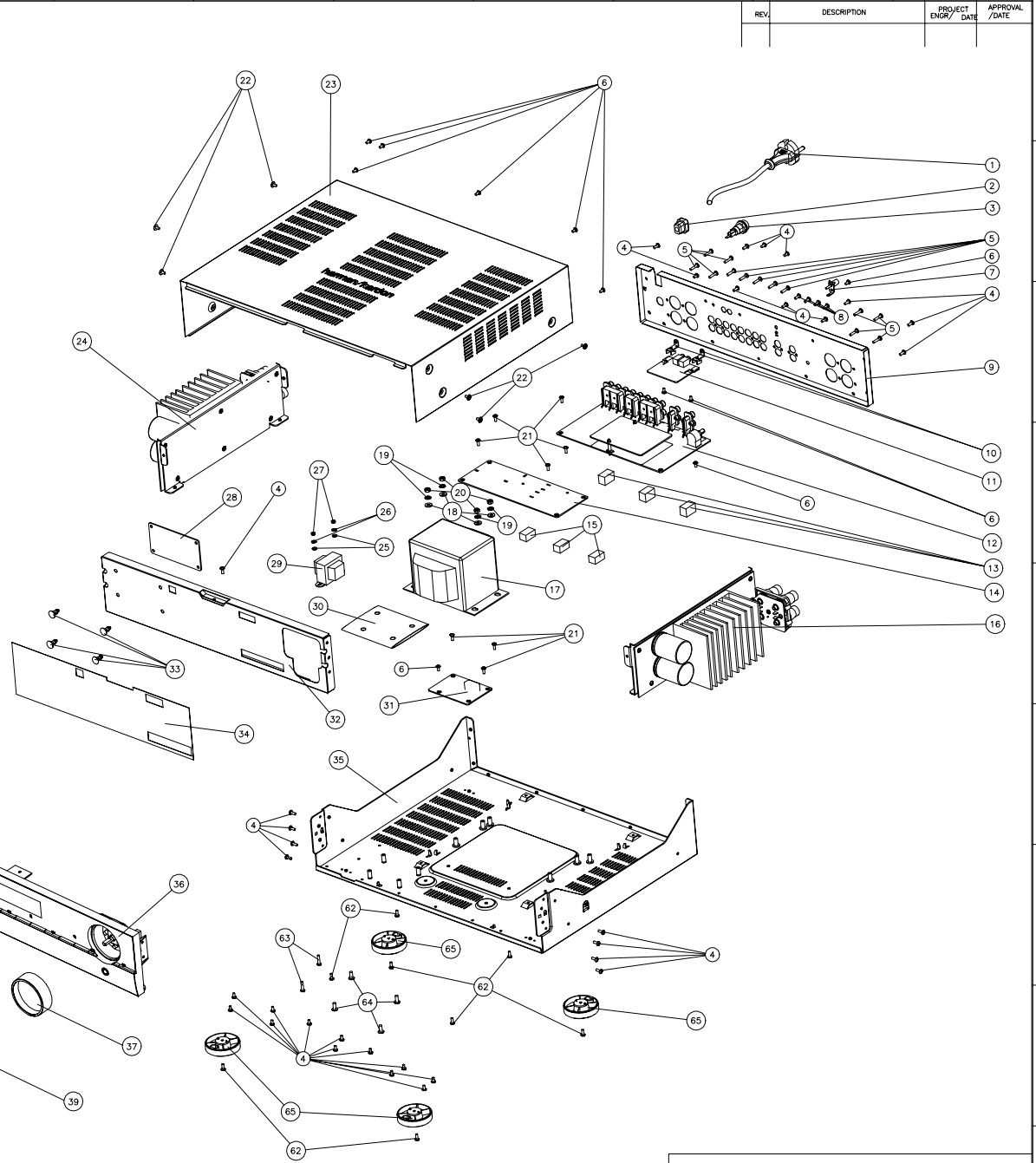

REV.	DESCRIPTION	PROJECT ENGR/ DATE	APPROVAL /DATE

NOTE :		FINISH		DRAWN BY		REVISED BY		APPROVED BY	
1. UNLESS OTHERWISE SPECIFIED :		MODEL		PART NAME		S. - EQ.		CF	
1. TOLERANCE : 0.2 - 50 mm 0.10		MAT'L		SIZE		PART NO.		REV.	
2. ALL DIMENSIONS ARE IN mm.		PROV. FILE:		A1					
3. BREAK ALL SHARP CORNERS.									
4. FOR SHEET METAL PARTS: BURRS < 0.04 & < 0.08 AT FINAL CUT OFF PORTION									

SCALE: 0.300

REV.	DESCRIPTION	PROJECT ENGR./DATE	APPROVAL /DATE

9
8
7
6
5
4
3
2
1

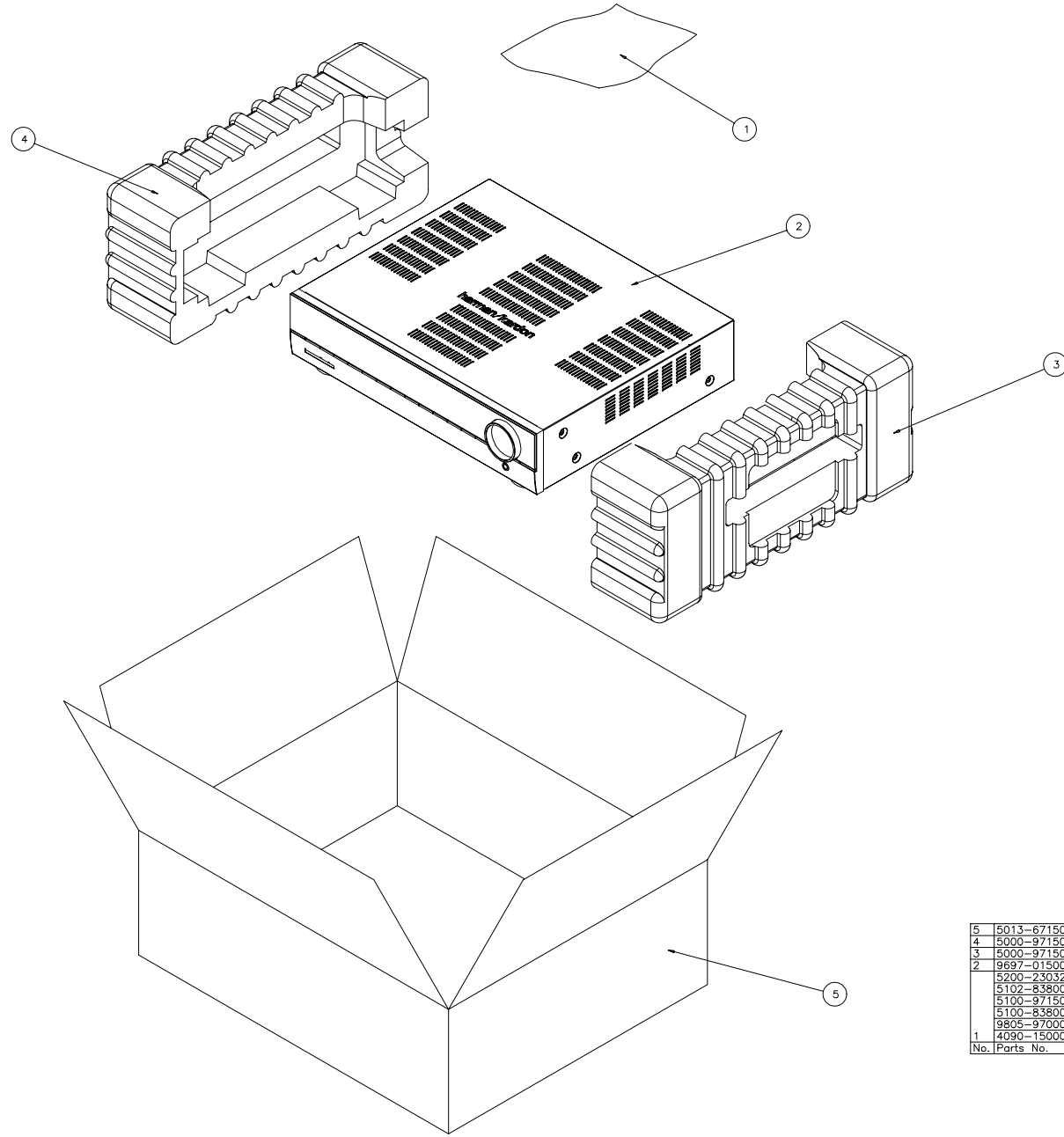

5	5013-671500-000	HARMAN KARDON HK970 (230V) CARTON BOX	1
4	5000-971500-201	POLYFOAM RIGHT FOR HK970	1
3	5000-971500-101	POLYFOAM LEFT FOR HK970	1
2	9697-015000-001	HK970 AMP MECHAN ASSY	1
	5200-230321-030	POLYBAG FOR ACCESSORIES	1
	5102-838000-000	HARMAN KARDON ADVERTISING BROCHURE (CONSIGNED)	1
	5100-971500-000	HARMAN KARDON HK970(230V) INST-MANUAL	1
	5100-838000-300	H/K SAFETY MANUAL FOR EUROPE (AC230V)	1
	9805-970000-001	HK970 REMOTE CONTROL UNIT	1
1	4090-150001-000	AA ALKALINE BATTERIES	2
No.	Parts No.	Description	Qty

NOTE :		FINISH	DRAWN BY	CHECKED BY	APPROVED BY
UNLESS OTHERWISE SPECIFIED :					
1. TOLERANCE : \pm .05 - .50 mm 0.10		MODEL	PART NAME		SHEET OF
.003 - 100 mm 0.15		MAT'L			
ANGLE : 2 0.5 DEG.		PROJ. FILE:	SIZE	PART NO.	REV.
2. ALL DIMENSIONS ARE IN mm.			A1		
3. BREAK ALL SHARP CORNERS.					
4. FOR SHEET METAL PARTS: BURS < .004					
R < .008 AT FINAL CUT OFF PORTION					

A B C D E F G H I J K L M