

**harman kardon**

MODEL A-400

# *The Counterpoint*

HIGH FIDELITY FM TUNER

OPERATION AND SERVICE INSTRUCTIONS

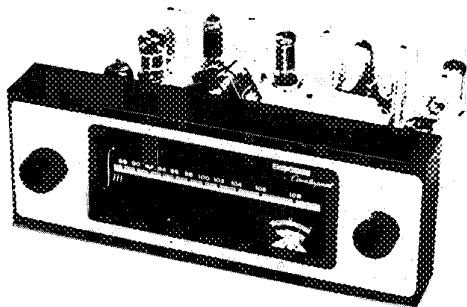

## UNPACKING:

After unpacking the Counterpoint, inspect it carefully for any signs of damage in transit. Your unit was subjected to many inspections and tests, and then carefully packed. If any damage is visible notify the transportation company at once.

Check the contents of the package carefully.

You should find:

- 1 Tuner, Model A-400
- 1 Instruction Booklet
- 1 Antenna wire, hanked
- 1 Shielded Output Cable
- 1 Warranty Card

It is strongly urged that the warranty card be completed and mailed without delay, to protect your rights under the warranty. If you should require repair service or information on the use of the Counterpoint, we will be able to identify your unit immediately, and respond quickly.

## CONNECTIONS:

### FM ANTENNA

Due to the extremely high FM sensitivity of the Counterpoint, the 48 inch wire furnished will be sufficient antenna for all but the most difficult locations. One end of the wire should be connected to the FM terminal of the ANTENNA terminal strip, the other end being left free and extended as may be convenient. In remote locations, a standard roof-top dipole and suitable twin leadin wire may be used, connected between the FM and G terminals.

### POWER

Plug the power cord into any outlet furnishing 117 volts, 60 cycles house current. The exact voltage is relatively unimportant, and may vary between 105 and 125. Be sure, however, that you have 60 cycle AC power. For many installations, such as with the Melody, Model C100 Amplifier, it will be more convenient, from an operational point of view, to plug the power cord of the Counterpoint into the convenience outlets provided on the amplifier chassis. The tuner will then be turned on or off by the amplifier power switch.

**HARMAN - KARDON, INC.**

520 MAIN STREET, WESTBURY LI, N.Y.

Two receptacles, marked "Output" will be found at the rear of the chassis. For your convenience in connecting to the amplifier, a 36" shielded cable will be found in the Counterpoint package. Plug one end of this cable into either one of the two output receptacles, and the other end into the appropriate amplifier input receptacle.

Since the output circuit of the Counterpoint includes a cathode-follower, this cable may be extended to any reasonable length without deterioration of tone quality.

The second output receptacle may be similarly connected to a tape recorder, to provide program material unaffected by the tone and volume controls of the amplifier.

The output level of the Counterpoint may be adjusted to suit the input requirements of the amplifier, or to balance with the volume of another program source (such as a record player), by means of the control marked "Output Level".

## VENTILATION:

All electrical equipment generates heat, which must be allowed to escape. Although the Counterpoint is well ventilated in itself, sufficient space should be allowed around it to permit free air flow. If it is placed in a bookcase, it should be located well toward the front, to provide as much clearance as possible at the rear.

Do not put books or other objects on top of the Counterpoint. Covering the perforated tube grill will reduce the ventilation and result in sharply reduced component and tube life.

## OPERATION:

### CONTROLS

The Harman-Kardon Counterpoint has only 2 front panel operating controls. The Tuning Knob (at the right) is used to tune to the desired station. The Power-AFC control (at the left) serves to turn the power off in its extreme counter-clockwise position. A small amount of rotation from this position will turn the power on, with a click, and further rotation serves to adjust the degree of Automatic Frequency Control up to a maximum at the extreme clockwise position.

### TUNING METER

The precise HARMAN-KARDON tuning meter operates whether AFC is in circuit or not. When the Counterpoint is tuned completely off any station, the tuning meter will point to zero. As you tune through a station, the needle will swing to one side, then to zero, then to the other side, and as you tune away from the station, back to zero. The tuning is proper only when the needle points to approximately zero.

FM Broadcasting, by its very nature, eliminates almost all natural and man-made static. However, the characteristics of FM which make this possible also make for problems in tuning. The HARMAN-KARDON Counterpoint incorporates an effective Automatic Frequency Control (AFC) circuit that overcomes these problems and insures proper tuning even if the manual tuning is not accurately done. The following experiment will lead to an understanding of AFC, and the fuller enjoyment of the Counterpoint. First, rotate the "Power-AFC" control to the extreme clockwise position. Now tune across the scale. Note how the stations "pop" into place, one after the other. Now tune to any station, preferably one with a musical program. Turn the "Power-AFC" control counterclockwise as far as possible without turning the set off. This defeats the AFC. Tune slowly through the station from left to right. Notice that there are three points where the station sounds clean, interspersed with points of distorted sound. The middle clean-sounding point is the proper tuning position for the best tone quality with minimum noise and interference. At this point the tuning meter will indicate proper tuning. Tune slightly away from the proper tuning position, until the sound is distorted. Note that the tuning meter will indicate improper tuning. Now reactivate the AFC by turning the "Power-AFC" knob to the right. You will notice that the sound cleans up and the proper tuning indication is restored, as if the receiver had been manually retuned.

Actually, the tuning has been electrically readjusted by the operation of the AFC circuit, which automatically retunes the electronic circuits to the center of the station channel.

The AFC circuit of the Harman-Kardon Counterpoint performs the further function of overcoming any tendency of the tuner to drift.

In order to take maximum advantage of the benefits of AFC, it is suggested that tuning be done with AFC off, to render the indication of the tuning meter more precise. When AFC is then turned on, the tuning will be improved by a ratio of 10 to 1.

This procedure is especially recommended in those areas where a weak station is found close to a strong station. Under this condition, the AFC may tend to reach for the strong station and completely skip over the weak one. If the weak station is tuned in without AFC, it will be locked in when the AFC is turned on.

Another procedure might be to find that setting of the AFC control which provides the exact amount of AFC action for most convenient tuning in your location.

To do this, tune to a portion of the dial where a strong station is found immediately adjacent to a weak station. (If this situation cannot be found in your location, leave the AFC control at maximum).

Now tune slowly through both stations, from the direction of the strong station. If the AFC control is set too high, the stronger station may be held until the tuning is past the weak station. Adjust the AFC so that when the stronger station pops out, the weaker station appears.

## MAINTENANCE AND REPAIR:

In some installations, hum may be encountered due to a voltage difference between the amplifier, tuner and record changer chassis. This may be eliminated by reversing one or all of the AC power plugs. Simply reverse one at a time until improvement is experienced.

Due to the conservative design and high quality components of the Counterpoint, no routine maintenance other than yearly tube-testing is required. Should trouble develop, however, only the most qualified serviceman should be employed, as special equipment and training is required to properly service high fidelity equipment.

This instruction booklet contains diagrams and other information needed by your repairman. It should be kept available for his use.

## ALIGNMENT PROCEDURE

Signal Freq.	Generator Mod.	Signal Input Point	Output Indicator	Connect Indicator To:	Dial Setting	Adjust	Output Indication
10.7MC	300KC FM 60 Cycles	6AU6 V2-Pin 1	AC-VTVM or scope	"A" on Schematic thru 100K	—	3 FM IF Transformers (T2,T3,T4) Limiter Transformer (T5)	Max gain and symmetry
10.7MC	300KC FM 60 Cycles	6AU6 V2-Pin 1	AC-VTVM or scope	"B" on Schematic	—		Max. gain
10.7MC	300KC FM 60 Cycles	6AU6 V2-Pin 1	AC-VTVM or scope	"B"	—	Discriminator Transformer	Pattern of Max gain and symm
106MC	300KC FM 60 Cycles	FM Ant. Terminals	AC-VTVM or scope	"A"	106MC	OSC, RF and Ant. Trimmer	Max. Output
90MC	300KC FM 60 Cycles	FM Ant. Terminals	AC-VTVM or scope	"A"	90MC	OSC, RF and Ant. Trimmer	Max. Output

## LIST OF REPLACEABLE PARTS

Description	Part No.	List Price
FM IF Transformer	GT 24605	2.70
FM Disc. Transformer	GT 24608	3.15
Power Transformer	FT 35986	8.50
RF Trimmer	JV 20688	.30
40,40/150V Electrolytic	JE 22637	1.95
Volume Control, 1 Meg.	RV 35996	1.25
AFC Control, 1 Meg. SPST Switch & Cover	RV 35931	2.50
Meter	Z 35942	9.00
Dial Glass	P 35938	1.25
Glass Retaining Clip	Z 35944	.05
Pointer	Z 24773	.30
Display Panel	P 35930	4.35
Escutcheon	P 35931	7.00
Knob	P 20778	.15
Knob (with white line)	P 351043	.20

## SPECIFICATIONS

### RF SECTION

CIRCUITS: FM: Armstrong Circuit with Dual Limiters (Double Tuned) and Foster-Seeley Discriminator Automatic Frequency Control. Low noise front end with tuned RF stage and triode mixer.

SENSITIVITY: FM: 3 microvolts for 30 db quieting; 2 microvolts for 20 db quieting.

SELECTIVITY: FM: 200 KC bandwidth: 6 db down.  
FM Discriminator peak to peak separation: 375 KC.

FREQUENCY RANGE: FM: 88-108 MC

FM DRIFT:  $\pm 2\frac{1}{2}$  KC with AFC on;  $\pm 20$  KC with AFC off

IMAGE REJECTION: FM: 50 db.

IF REJECTION: FM: 70 db.

ANTENNA INPUT: FM: 300 ohms

DISTORTION: Less than 1% harmonic

FREQUENCY RESPONSE:  $\pm \frac{1}{2}$  db 20-20,000 c.p.s.

HUM LEVEL: 60 db below 100% modulation

### AUDIO SECTION

CIRCUITS: Cathode Follower Output

OUTPUT LEVEL: 3 volts for 100% modulation; 1 volt for 30% modulation (level set control permits 20 db reduction).

OUTPUT IMPEDANCE: Low Impedance Cathode Follower

### OVERALL SPECIFICATIONS

CONTROLS: (Total 2) Power/variable AFC and Tuning

TUBE COMPLEMENT: (Total: 8) 1-6U8, 1-12AT7, 4-6AU6, 1-6AL5, 1-12AU7, Selenium Rectifier.

DIMENSIONS: 11-1/8" wide x 4" high x 7 1/2" deep (not including knobs).

POWER CONSUMPTION: 35 watts

SHIPPING WEIGHT: 8 1/2 lbs.

FINISH: Chassis and escutcheon: brushed copper - Display panel for escutcheon and knobs: matt black - Edge lighted dial glass: yellow and white.

ACCESSORY MATERIAL FURNISHED: FM antenna wire, instruction booklet, shielded output cable.

FUNCTIONAL FEATURES: (a) Counterweighted Tuning Control; (b) Variable AFC control; (c) Output Level Control; (d) Illuminated Discriminator Balance Tuning Meter.

SPECIAL NOTES: (a) Can be stacked with C-100 amplifier in total height of 7 3/4"; (b) Face up mounting of Counterpoint permissible without special precaution.

### OPTIONAL ACCESSORIES

(a) Metal Cage (Model AC-4) finished in matching brushed copper, furnished with mounting hardware and instructions.

(b) Brass finished escutcheon available on special order.

(c) Brass finished cage available on special order.

(d) Vertically calibrated dial glass available on special order.

## WARRANTY:

We warrant each Counterpoint, Model A-400 to be free from defects in material and workmanship under normal use and service, and in accordance with the conditions herein below set forth, for a period of 90 days from date of delivery to the original purchaser, and agree to replace or repair any part or parts returned to us within said 90 days, with transportation prepaid, and which our examination shall disclose to our satisfaction to have been thus defective. This warranty does not include free labor, nor is it applicable to any instrument which shall have been repaired or altered in any way so as in our judgment to affect its stability or reliability nor which has been subject to neglect, misuse, abuse, negligence or accident nor which has had the serial number altered, effaced, or removed. Neither shall this warranty apply to any instrument which has been connected otherwise than in accordance with the instructions furnished by us.

This warranty is expressly in lieu of all other warranties, express or implied, and of all other obligations or liabilities on our part, and we neither assume nor authorize any representative or other person to assume for us any other liability in connection with the sale of the Model A-400 Counterpoint.

# A 400

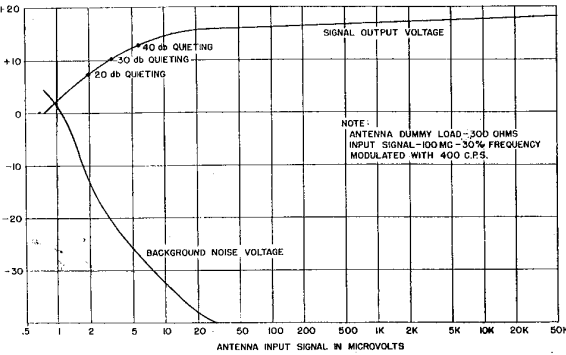
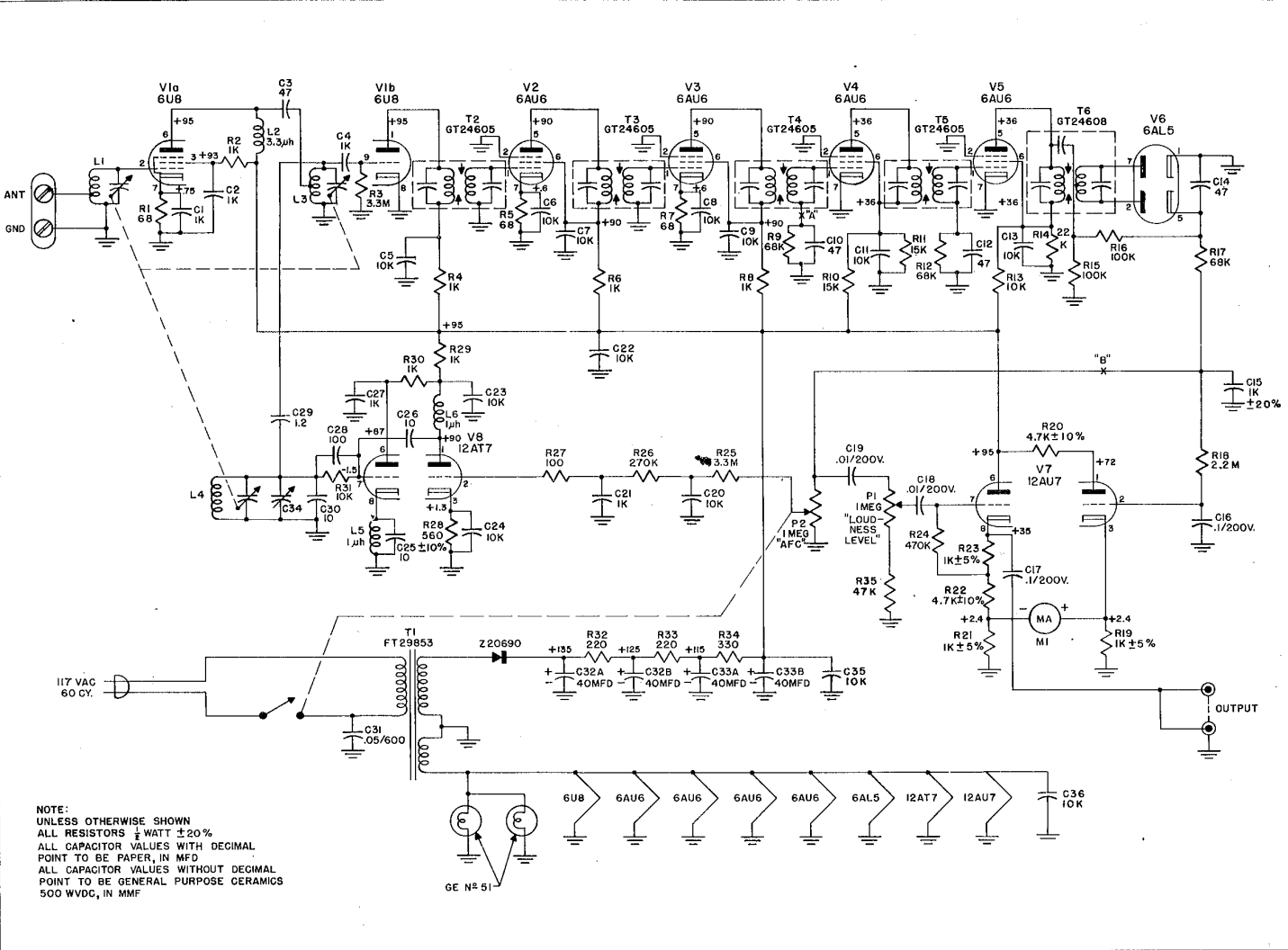

FM detector voltage characteristics

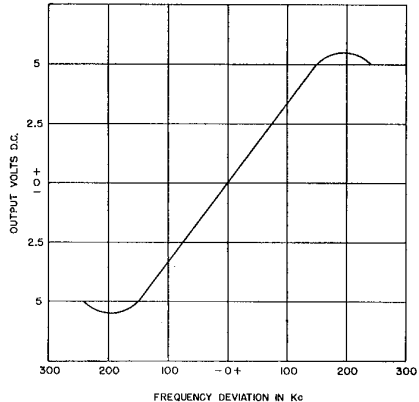

FM discriminator characteristics

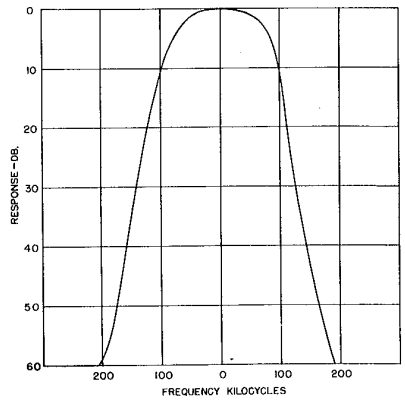

FM selectivity characteristics

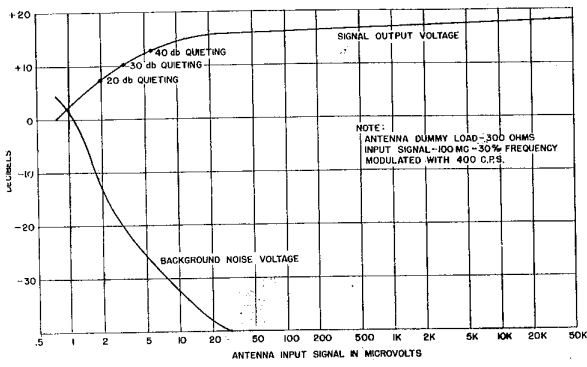
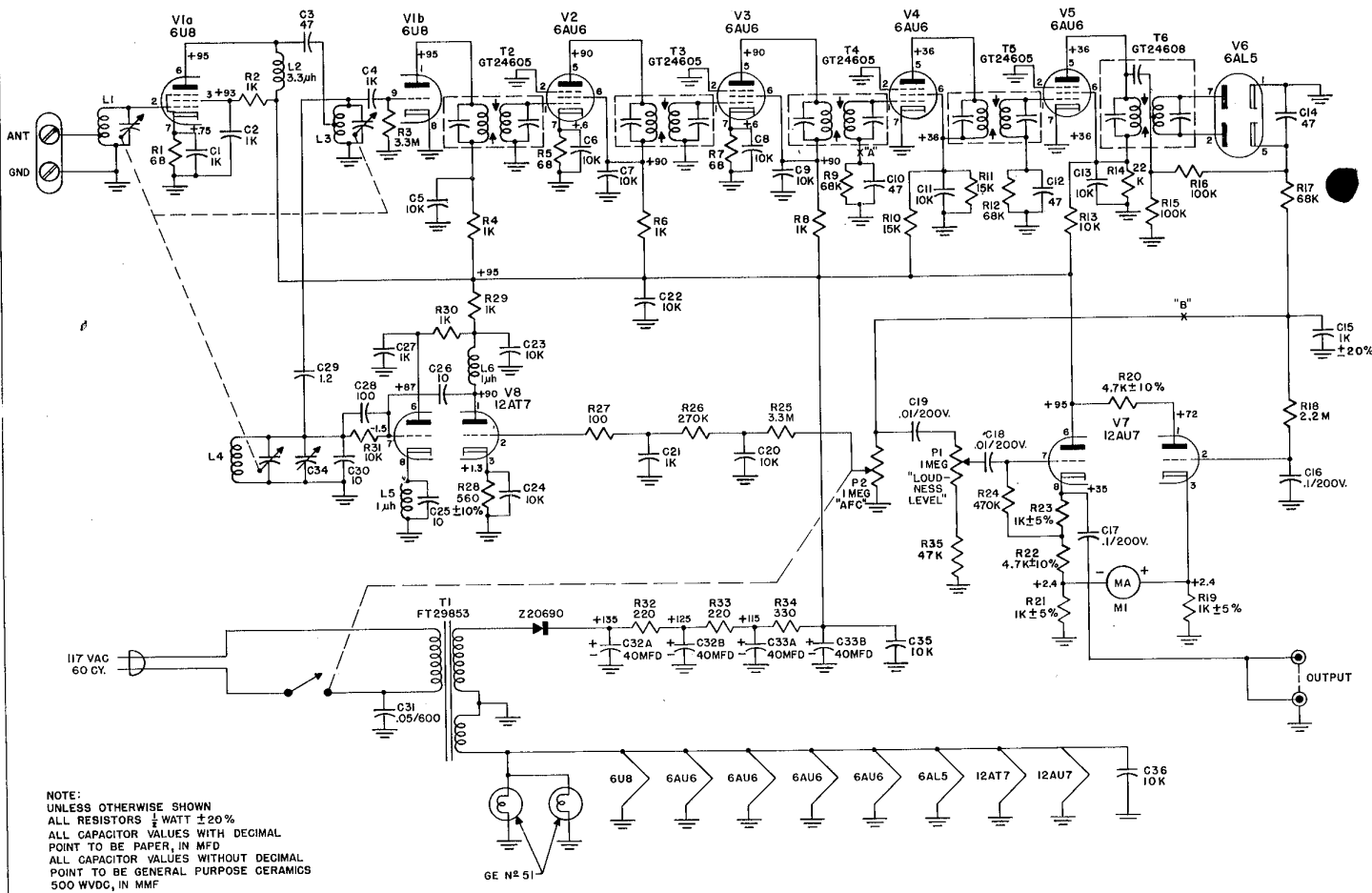

FM detector voltage characteristics

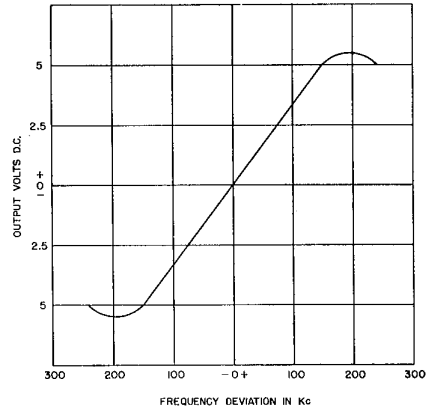

FM discriminator characteristics

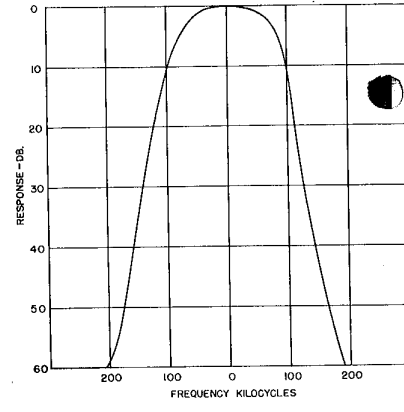

FM selectivity characteristics