

The Harman Kardon
Model AVI200MKII
AUDIO AND VIDEO AMPLIFIER

Technical Manual

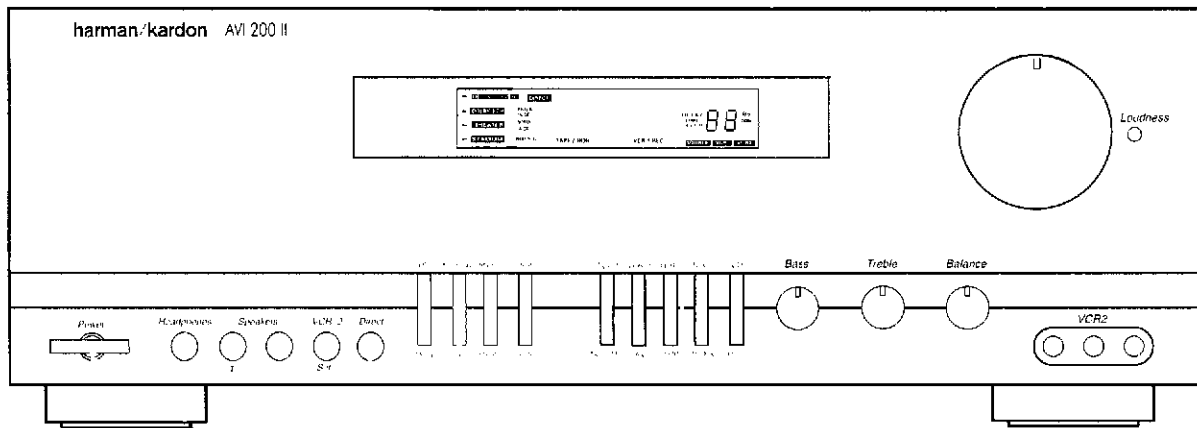

■ CONTENTS ■

SPECIFICATIONS	2	GENERAL UNIT	14
LEAKAGE TEST	3	PRINTED CIRCUIT BOARDS	15
BLOCK DIAGRAM	4	ELECTRICAL PARTS LIST	17
CONTROLS AND FUNCTIONS	5	IC FUNCTIONAL BLOCK DIAGRAM	22
CIRCUIT DESCRIPTION	6	WIRING DIAGRAM	26
DISASSEMBLY PROCEDURES	10	SCHEMATIC DIAGRAM (I)	27
TROUBLESHOOTING	11	SCHEMATIC DIAGRAM (II)	28
GENERAL UNIT PARTS LIST	13	SCHEMATIC DIAGRAM (III)	29

harman/kardon

Parts and Service Office
 80 Crossways Park West, Woodbury, N.Y. 11797
 1112-AVR200MKII G9604 1200 Printed in Korea

SPECIFICATIONS

FRONT AMP SECTION

	Nominal	Limit
RMS Output Power		
THD (0.2%, 8 ohms, 1 kHz)	≥ 68 W	≥ 65 W
Both Channel Driven (20 Hz - 20 kHz)		
THD (20 Hz - 20 kHz) at 65 W, 8 ohms		
20 kHz	≤ 0.09%	≤ 0.2%
1 kHz	≤ 0.09%	≤ 0.2%
20 kHz	≤ 0.09%	≤ 0.2%
IM Distortion at 65 W, 8 ohms		
60:7000 Hz = 4:1	≤ 0.1%	≤ 0.2%
Input Sensitivity at 65 W, 8 ohms		
PHONO (MM)	2.5 ± 0.2 mV	2.5 ± 0.3 mV
CD, AUX, VCR	150 ± 20 mV	150 ± 30 mV
S/N Ratio Input Shorted at Volume Max. (WTD IHF-A) at 65 W, 8 ohms		
PHONO	≥ 72 dB	≥ 65 dB
CD, AUX	≥ 91 dB	≥ 85 dB
TV, VCR1,2	≥ 91 dB	≥ 85 dB
Phono Overload at 1 kHz, THD: 0.5%		
Phono Input → Tape Monitor Output	≥ 140 mV	≥ 120 mV
Phono Equalization (RIAA 30 Hz - 15 kHz)		
Tape Monitor Output	RIAA ± 1.0 dB	RIAA ± 2.0 dB
Tone Control		
Bass: 100 Hz	+10 ± 1.0 dB	+10 ± 2.0 dB
	-10 ± 2.0 dB	-10 ± 3.0 dB
Treble: 10 kHz	+10 ± 1.0 dB	+10 ± 2.0 dB
	-10 ± 2.0 dB	-10 ± 3.0 dB
Loudness Contour at -40 dB		
100 Hz	+6 ± 2.0 dB	+6 ± 3.0 dB
10 kHz	+3 ± 2.0 dB	+3 ± 3.0 dB
Frequency Response at 1 W, 8 ohms		
CD/AUX		
20 Hz, 20 kHz	± 1.0 dB	± 2.0 dB
Channel Crosstalk Input Shorted at 65 W, 8 ohms		
1 kHz	≥ 55 dB	≥ 48 dB
10 kHz	≥ 45 dB	≥ 37 dB

CENTER AMP SECTION

	Nominal	Limit
RMS Output Power		
THD (0.2%, 8 ohms, 1 kHz)		
Only Center Channel Driven	≥ 68 W	≥ 63 W
S/N Ratio		
Input Shorted, IHF-A WTD	≥ 75 dB	≥ 68 dB
Frequency Response at -3 dB		
Normal	130 Hz - 20 kHz	180 Hz - 15 kHz
Wide	40 Hz - 20 kHz	60 Hz - 15 kHz

REAR AMP SECTION

	Nominal	Limit
RMS Output Power		
THD (1%, 8 ohms, 80 Hz - 7 kHz)		
Both Rear Channel Driven	≥ 27 W	≥ 23 W
S/N Ratio (Input Shorted, IHF-A WTD)		
Dolby	≥ 65 dB	≥ 57 dB
Stadium	≥ 65 dB	≥ 57 dB
Theater	≥ 65 dB	≥ 57 dB
Frequency Response at -3 dB		
8 ohms, Dolby Pro-Logic	100 Hz - 6 kHz	120 Hz - 5 kHz

VIDEO AMP SECTION

	Nominal	Limit
Input Sensitivity/Impedance		
VCR1, VCR2, VDP	1 V _{p,p} /75 Ω	± 0.5 dB
Output Level/Impedance		
VCR1, REC out, TV Monitor out	1 V _{p,p} /75 Ω ± 0.3 d	± 1.0 dB
Frequency Response at -3 dB	DC-10 MHz	5 - 6 MHz
Crosstalk at 1.0 MHz	≥ 50 dB	≥ 43 dB

GENERAL

Power Consumption;	
USA/Canada	2.5 A
Europe	650 W
Power Supplies;	
USA/Canada	AC 120 V, 60 Hz
Europe	AC 230 V, 50 Hz
Dimensions (W × H × D);	
inches	17 ^{3/8} × 6 ^{1/8} × 16 ^{1/2}
mm	440 × 155 × 420
Weight (lbs/kgs)	26.9/12.2

These specifications are service target specs.

Specifications and components are subject to change without notice.

Overall performance will be maintained or improved.

LEAKAGE TEST

Before returning the unit to the user, perform the following safety checks:

1. Inspect all lead dress to make certain that leads are not pinched or that hardware is not lodged between the chassis and other metallic parts in the unit.
2. Be sure that any protective devices such as nonmetallic control knobs, insulating fishpapers, cabinet backs, adjustment and compartment covers or shields, isolation resistor-capacity networks, mechanical insulators, etc. Which were removed for servicing are properly reinstalled.
3. Be sure that no shock hazard exists; check for leakage current using Simpson Model 229 Leakage Tester, standard equipment item No. 21641, RCA Model WT540A or use alternate method as follows: Plug the power cord directly into a 230-volt AC receptacle (do not use an Isolation Transformer for this test).

Using two clip leads, connects a 1500 Ohm, 10-watt resistor paralleled by a 0.15 μ F capacitor, in series with all exposed metal cabinet parts and a known earth ground, such as a water pipe or conduit. Use a VTVM or VOM with 1000 Ohms per volt, or higher sensitivity to measure the AC voltage drop across the resistor. (See Diagram.) Move the resistor connection to each exposed metal part having a return path to the chassis (antenna, metal cabinet, screw heads, knobs and control shafts, escutcheon, etc.) and measure the AC voltage drop across the resistor. (This test should be performed with the power switch in both the On and Off positions.)

A reading of 0.35 volt RMS or more is excessive and indicates a potential shock hazard which must be corrected before returning the unit to the owner.

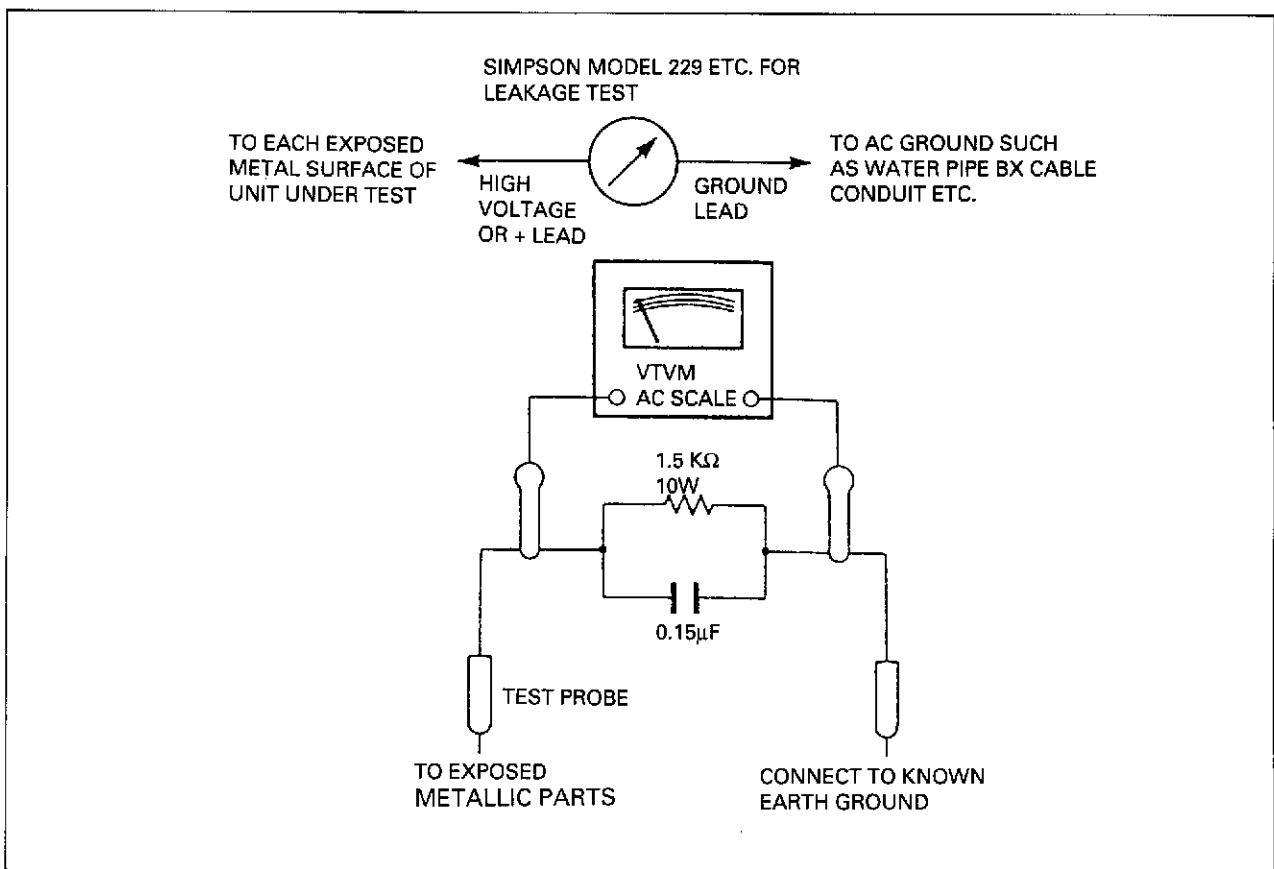

BLOCK DIAGRAM

DAT
 CONT
 LIN
 -NI
 -SL
 -TU
 -M/
 -PC

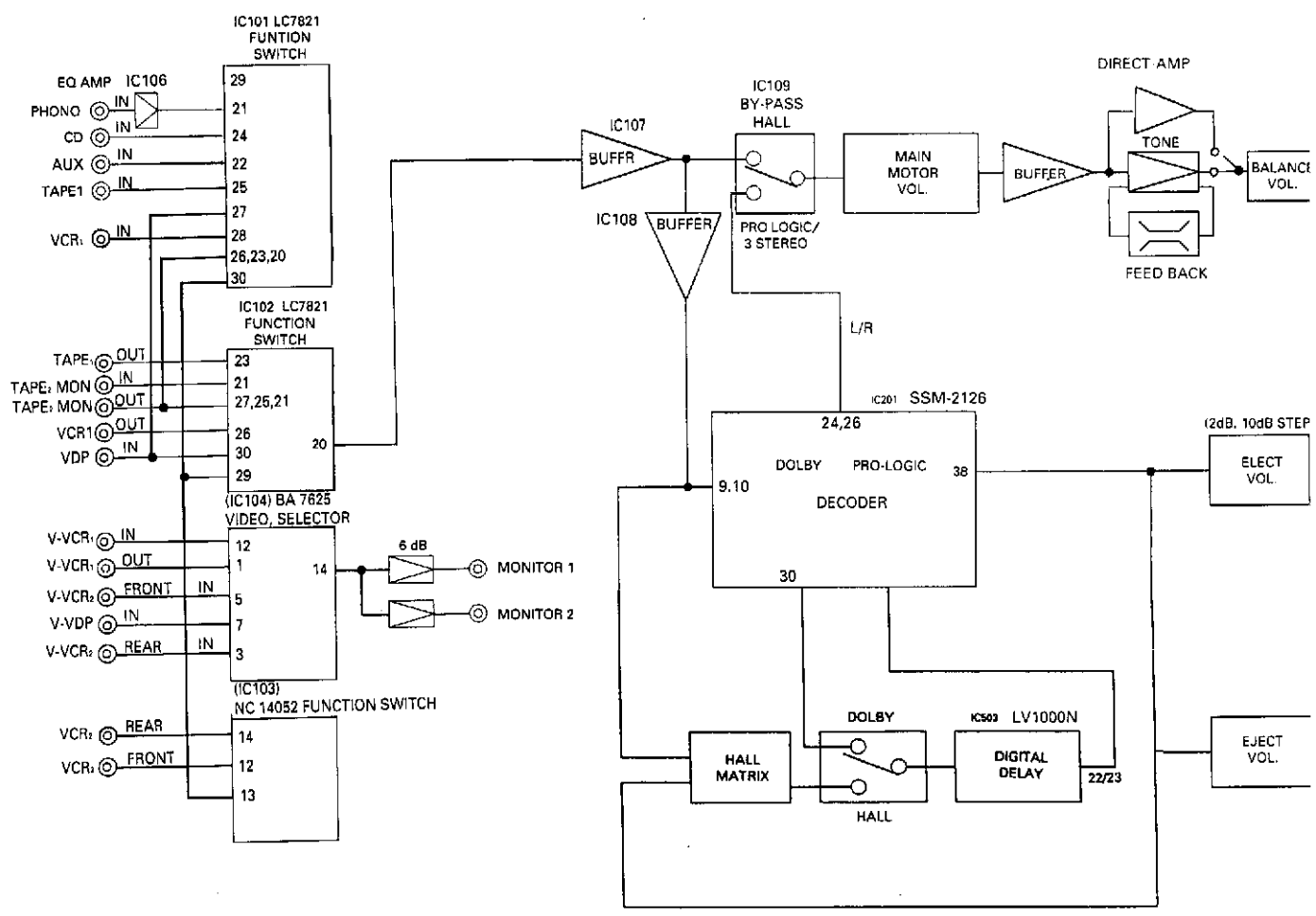

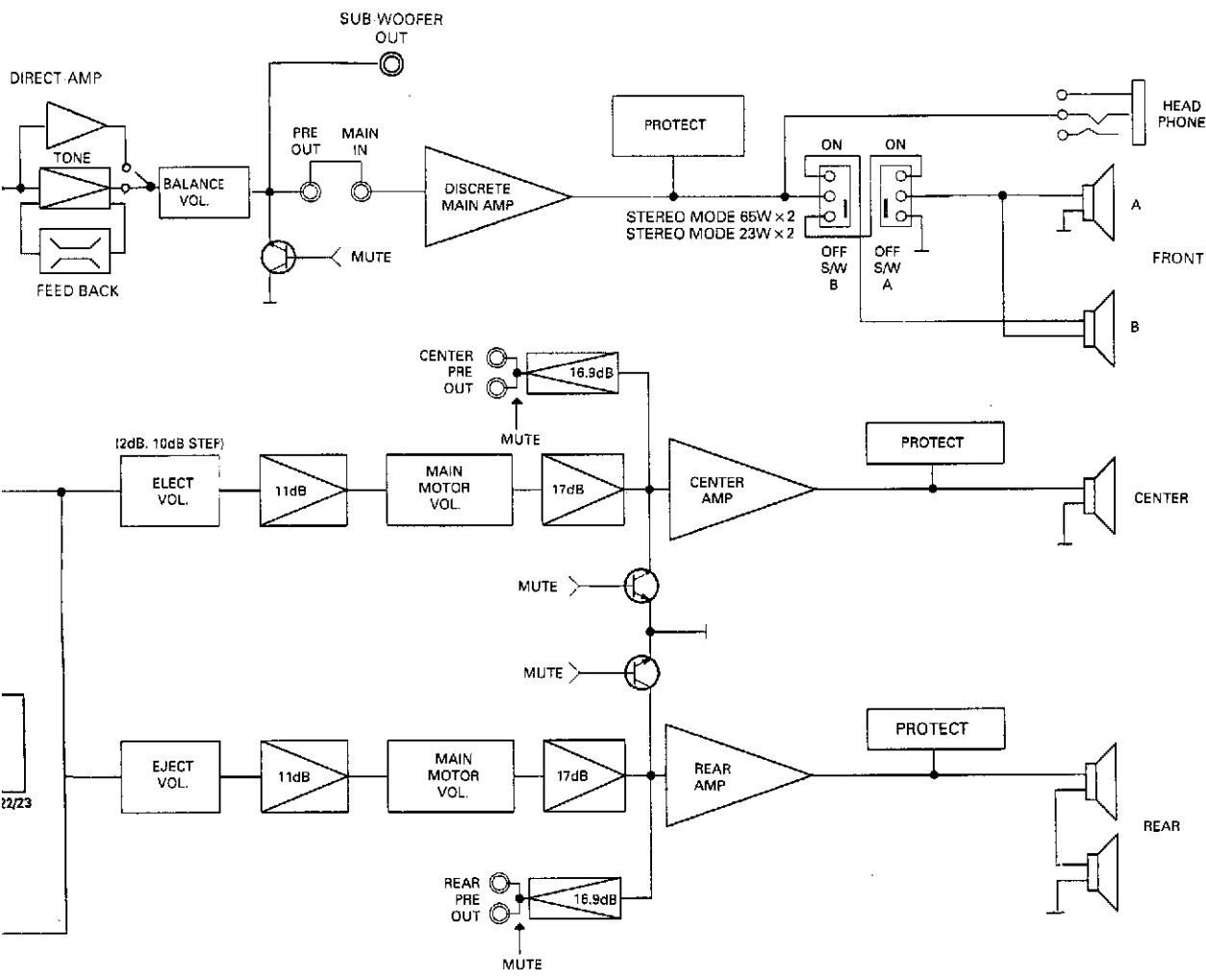
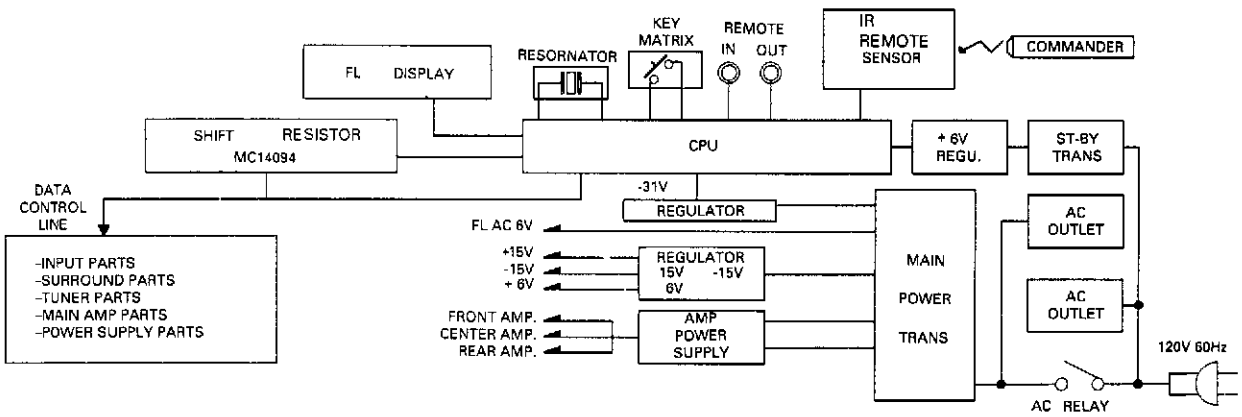

CONTROLS AND FUNCTIONS

7 9 13

22

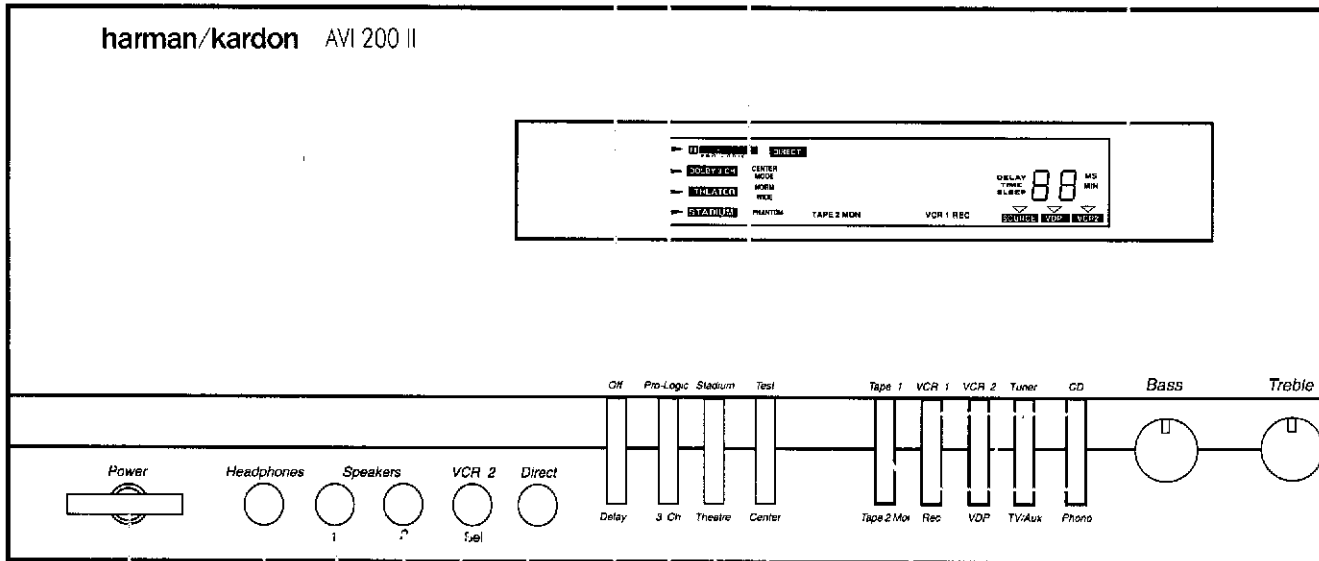

1

3

2

17

14

8

10

11

12

15

16

4

5

1. POWER BUTTON

Press this button to turn the power on. Press again to turn the power off. It can also be used as a system power button, if you connect the other components to the switched outlets.

NOTE: In POWER OFF state, the POWER indicator will light up orange and power is partially supplied to the infrared remote control receiver and the memory circuitry.

2. 1/2 SPEAKER SWITCHES

These switches allow you to select various combinations of speakers as follows;

- To drive 1 pair of speakers, push only the speaker 1 switch in.
- To drive a second pair of speakers, push only the speaker 2 switch in.
- To drive both pairs of speakers, push both 1 and 2 switches in.

- To use headphones for private listening or monitoring, leave both 1 and 2 switches pushed out.

NOTE: If both speaker switches are pushed in and only one set of speakers is connected to the amplifier, no sound will be heard.

3. HEADPHONE JACK

Stereo headphones can be plugged into this jack for private listening. Headphone impedance should be between 8 and 2K ohms. Best results between 200 and 400 ohms.

4. BASS CONTROL

Modifies the low-frequency sound of the left and right channels as much as +/- 10dB. Set this control at a suitable position for your taste and room acoustics.

5. TREBLE CONTROL

Modifies the high-frequency sound the left and right channels as much +/- 10dB. Set this control at a suitable position for your taste and room acoustics.

6. BALANCE CONTROL

This control is used for balancing the relative sound volume of the left and right channel speakers. Clockwise rotation reduces the volume from the left speaker, counterclockwise rotation reduces the volume from the right speaker.

7. SURROUND-OFF MODE SELECTOR

Press this switch to select normal stereo mode.

21

20

19

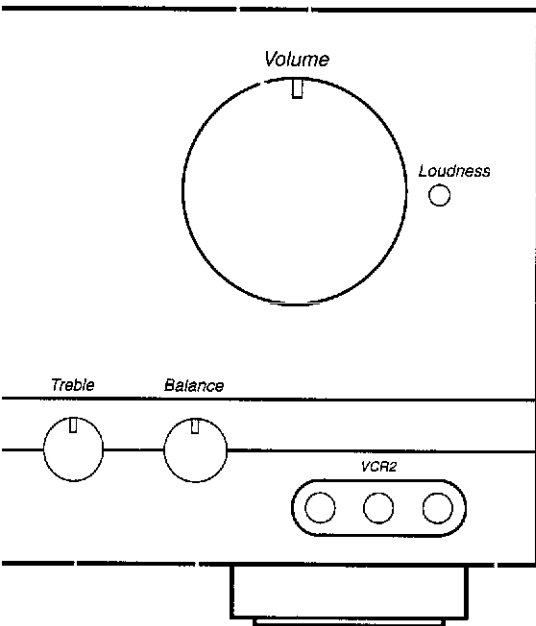

11. STADIUM/THEATER MODE

Switches for selecting desired surround mode; Stadium or Theater. See Surround Sound Effects on page 13.

12. CENTER MODE SELECTOR

This button operates only in Dolby Pro Logic and Dolby 3 Stereo mode. The mode changes as below, when the button is pressed in succession.

DOLBY PRO LOGIC MODE

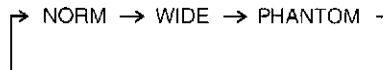

DOLBY 3 STEREO MODE

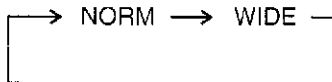

The display window shows each mode.

NORM: Select this mode if you use a small center speaker. The bass sound of the center channel is reproduced from the front speakers, because the small speaker cannot produce enough bass.

WIDE: Select this mode if you use a medium-to-large center speaker. The bass sound is reproduced from the center speaker.

PHANTOM: Select this mode if you don't use a center speaker. The center speaker's sound is reproduced from the front speakers.

13. TEST TONE BUTTON

This button operates only in Dolby Pro Logic and Dolby 3 Stereo mode. When the button is pressed, 2 seconds of test tone is generated in all channels (Left, Center, Right, and Rear) in succession. The display window shows TEST Left, Center, Right, and Rear in succession (in Dolby Pro Logic mode) or Left Center or Right (in Dolby 3 stereo mode) in succession. Use this button to test speaker connections.

14. SOURCE/DIRECT BUTTON

This feature bypasses the tone control circuitry, resulting in flatter frequency response and wider bandwidth. When it is activated, "DIRECT" illuminates in the display.

15. TAPE 2 MONITOR BUTTON

Set TAPE 2 MON to the "off" position when you want to hear the other input functions. Press this button to monitor the cassette deck connected to the TAPE 2 MON input jacks.

16. INPUT FUNCTION SELECTOR

Press the button to select the desired input function: VCR 1, VCR 2, VDP, TAPE 1, TV/Aux, Tuner, CD or Phono.

To dub from VCR 2 to VCR 1, press the VCR 2 button and then press the VCR 1 REC button.

For the input function of VCR 1 press the VCR 2 button and VCR1 DUBBING button. Set the recording VCR (VCR 1) to recording mode. Set the playback VCR (VCR 2) to playback mode.

Dubbing will start.

■ To hear another input source during video tape dubbing: Press the input function you want to hear, and play the input source.

17. VCR 2 SELECTOR

Push in this button to select the VCR 2 jacks on the front, rather than the VCR 2 jacks on the rear.

18. VCR 2/CAMCORDER INPUT JACKS

VIDEO IN:

Connect to the VIDEO OUTPUT jack of a VCR.

AUDIO IN:

Connect to the AUDIO OUTPUT jacks of a VCR.

19. LOUDNESS BUTTON

Press this button to compensate for the response of the human ear at low listening levels (known as the Fletcher-Munson hearing curve). The high and low frequencies are automatically boosted when this button is pushed in. In the OFF position, the frequency response is flat at all volume levels. This button does not work at high volume levels.

20. VOLUME CONTROL

Turn the VOLUME clockwise to increase the volume and counterclockwise to decrease it. The volume of the front, center, and rear channels is changed at the same time.

21. VOLUME LEVEL INDICATOR

This indicator moves in accordance with the volume level. The indicator blinks when the mute button on the remote commander is pressed.

22. DISPLAY WINDOW

This window shows the state of operation for easier control of the amplifier. It also contains the IR Remote Sensor.

5

6

18

8. DELAY TIME

Adjusts time delay between front and rear channels, operates only when the surround mode is on. (see Delay Time button on page 16).

Adjusts the surround delay time in steps. For Dolby Surround 20ms is standard

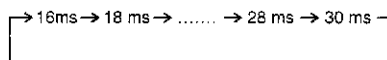

9. PRO LOGIC MODE

Press this button for Pro-Logic mode.

10. 3 CHANNEL MODE

The 3 channel mode can be used when rear speakers are not being used to provide a center (dialog) channel.

CIRCUIT DESCRIPTION

CPU (IC801) : CXP82220-107Q (8 bit SINGLE-CHIP MICROCOMPUTER)

1. Pin Connection Diagram & Block Diagram

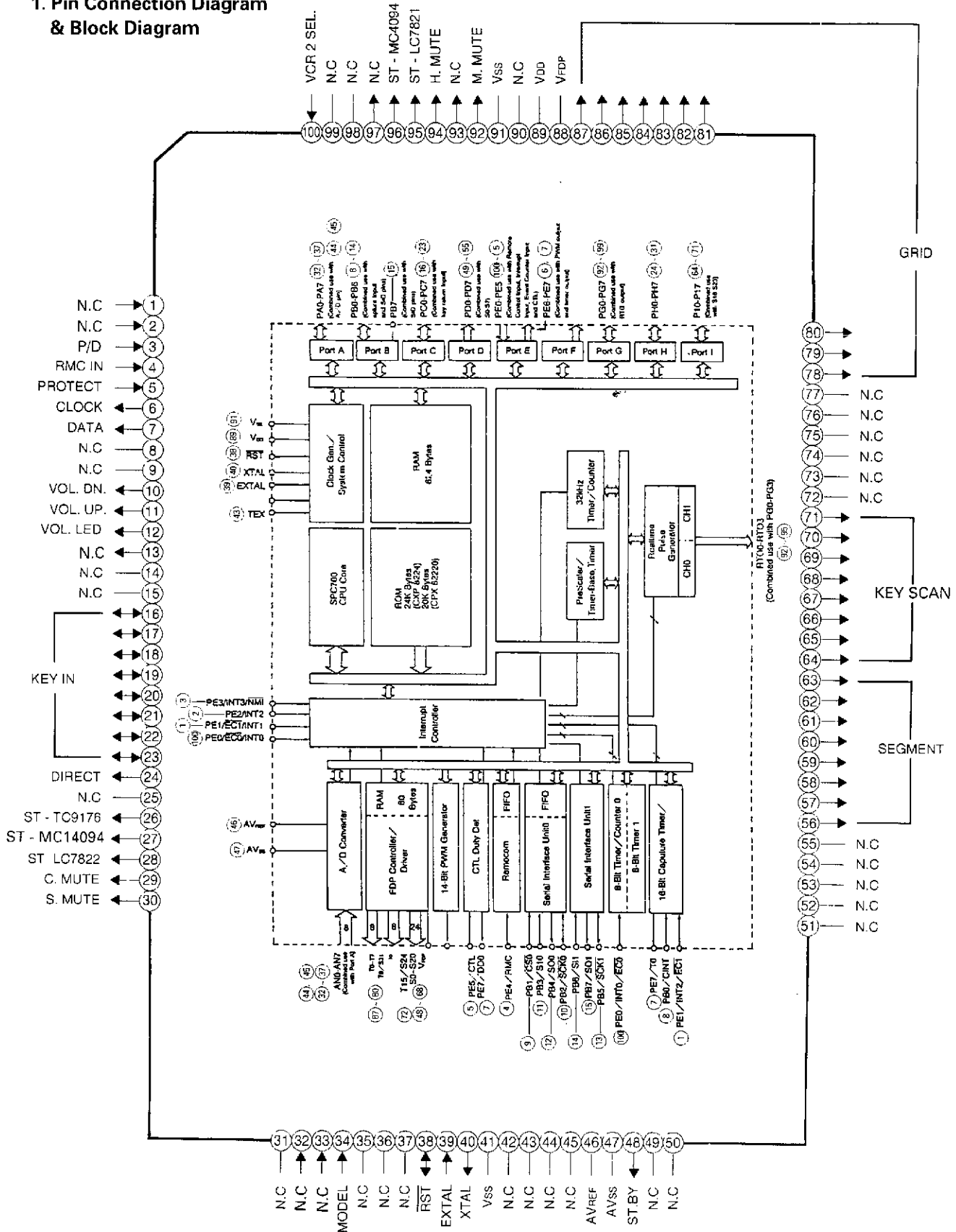

2. Pin Functions

Pin No.	Symbol	Description
1 / 2	N.C	Not used!
3	P / D	Input to detect power down. (At "L", it is active.)
4	RMC IN	Input for remote control signal. (At "L", it is active.)
5	PROTECT	Signal input for protection. (At "L", it is active.)
6 / 7	CK / DA	Clock / Data output for LC7821, GD4094, TC9213 and LM7001.
8 / 9	N.C	Not used !
10	VOL. DOWN	Output to drive volume motor for decreasing volume level. (At "H", it is active.)
11	VOL. UP	Output to drive volume motor for increasing volume level. (At "H", it is active.)
12	VOL. LED	Output to drive volume LED.
13~15	N.C	Not used !
16 - 23	KEY IN	Data input for key scan.
24	DIRECT	Output to allow sound signal to by-pass tone control circuitry. (At "H", it is active.)
25	N.C	Not used !
26	ST-TC9176	Chip enable output for TC9176.
27	ST-MC14094	Chip enable output for MC14094.
28	ST-LC7822	Chip enable output for LC7822.
29	C. MUTE	Output for center mute. Output, "H" under the following conditions. 1. When power is turned on or off. 2. When center mode is turned on or off. 3. When center mode is selected. 4. When test tone mode is on or off or when the channel is changed in the test tone mode. 5. When the protection terminal's level is "L". 6. When "-∞" mute signal is received from the commander.
30	S. MUTE	Output for surround mute. Output, "H" under the following conditions. 1. When power is turned on or off. 2. When surround mode is selected. 3. When test tone mode is on or off or when channel is changed in the test tone mode. 4. When adjusting delay time. 5. When the protection terminal's level is "L". 6. When "-∞" mute signal is received from the commander.
31~33	N.C	Not used !

Pin No.	Symbol	Description
34	MODEL	Input to select. (At "L" is selected).
35 - 37	N.C	Not used ! (Connected to V_{DD})
38	RST	Input to reset CPU.
39	EXTAL	Input for crystal osillator.
40	XTAL	Output for crystal osillator.
41	V_{SS}	Ground.
42	N.C	Not used !
43 - 45	N.C.	Not used ! (Connected to V_{DD})
46	AV_{ref}	Reference voltage. (Connected to 5 V, not V_{DD} .)
47	AV_{SS}	Ground.
48	ST.BY	When power is on, control data output is "H". When power is off, control data output is "L" and last memory function is activated.
49 - 55	N.C	Not used !
56 - 63	SEGMENT	Segment signal output for FIP.
64 - 71	SEGMENT / KEY SCAN	Segment signal output for FIP and Data output for key scan.
72 - 77	N.C.	Not used !
78 - 87	GRID	Grid signal output for FIP.
88	V_{FDP}	Power supply for FIP controller.
89	V_{DD}	+5 V power supply.
90	N.C	Not used !
91	V_{SS}	Ground.
92	M. MUTE	Output for main mute. Output is "H" under the following conditions. 1. When power is turned on or off. 2. When function is changed. 3. When the protection terminal's level is "L". 4. When "-∞" mute signal is received from the commander.
93		Not used!
94	H. MUTE	Output for headphone mute. Output, "H' under the following conditions. 1. When power is turned on or off. 2. When selecting the input function. 3. When the protection terminal's level is "L". 4. When "-∞" mute signal is received from the commander.
95	ST-LC7821	Chip enable output for LC7821.
96	ST-MC4094	Chip enable output for MC4094.
97~99	N.C	Not used !
100	VCR 2 SEL.	Input to select VCR 2 rear or front. At "H", VCR 2 rear is selected and at "L", VCR 2 front is selected.

3. Protection Circuits

Speaker Protection Circuits

The CPU protects both this unit and the speakers when an abnormally high current flows in Q262 L/R/C and Q263 L/R/C due to excessive input drive, too low of a load impedance, or short of the speaker terminals. If current increase is excessive, the voltage across R273 L/R/C or R274 L/R/C turns on Q264 L/R/C, then Q268 turns on Q269.

It makes the protection port of the CPU to low state, Then the power is turned off.

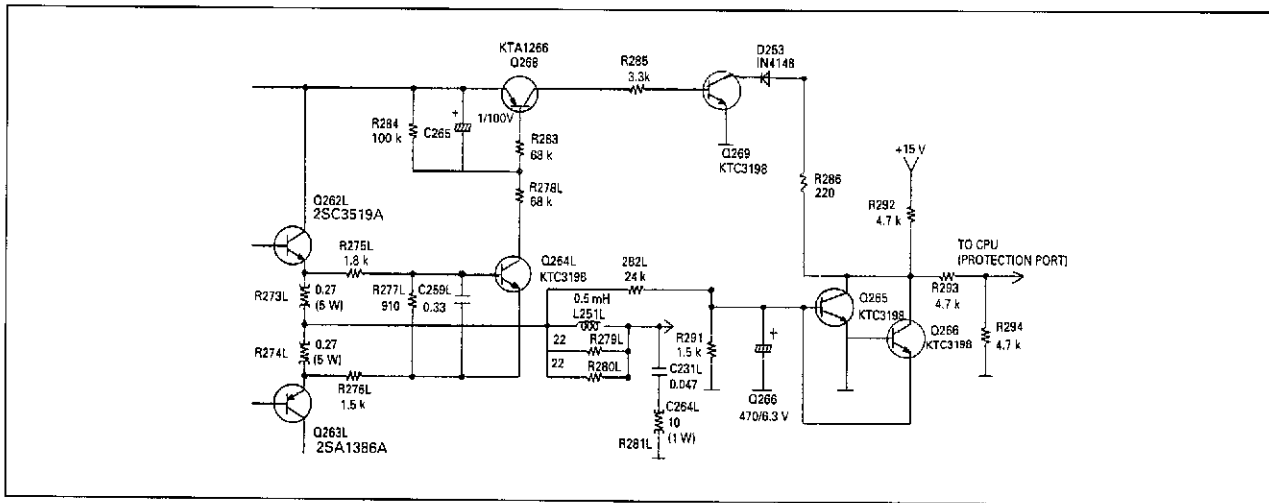

Thermal Protection Circuits

This unit has a overload thermal protection circuits to guard against abnormal operation. When the temperature of TRANS POSISTOR installed with the main transformer or H/SINK POSISTOR rises abnormally, the resistance of the posistor becomes larger and Q221 is turned on. It makes the protection port of the CPU to low state. Then the power is turned off.

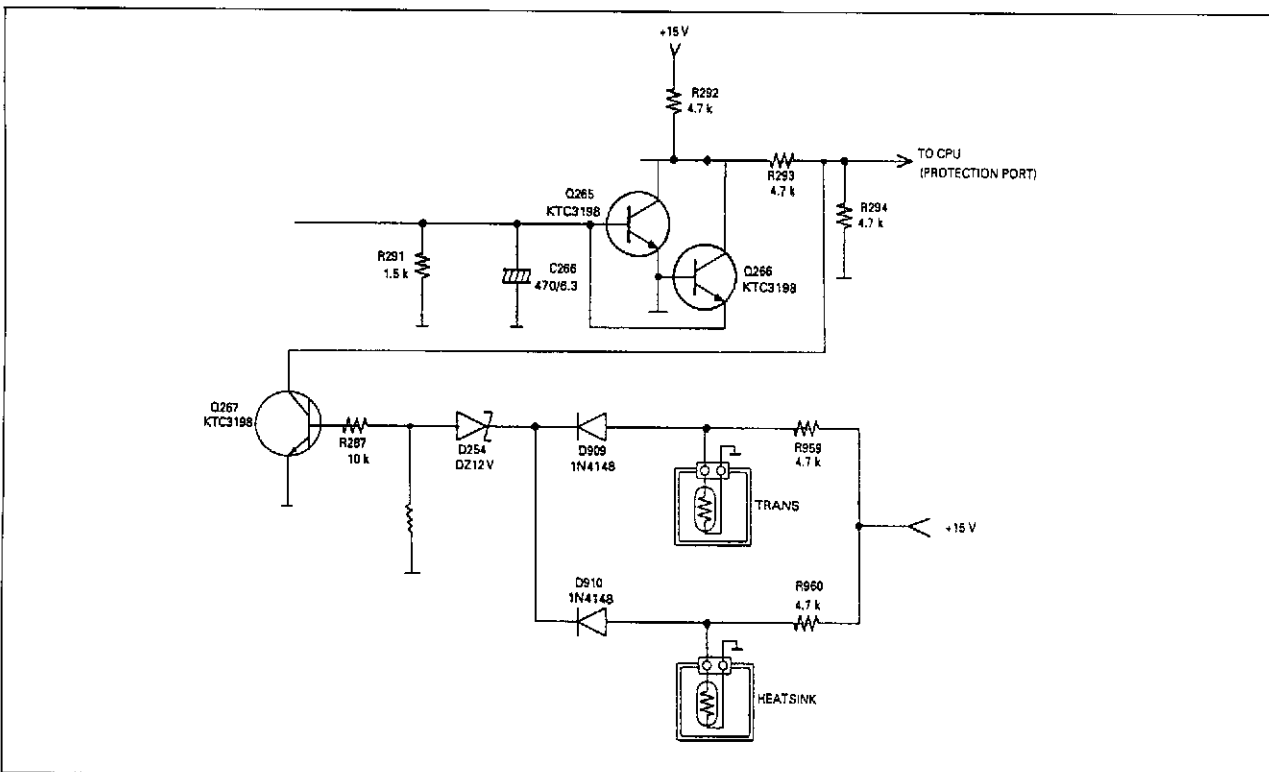

DISASSEMBLY PROCEDURES

REFER TO PAGES 23 AND 37.

1 COVER TOP REMOVAL

Remove 8 screws (A) and then remove the Cover Top (61).

2 COVER BOTTOM REMOVAL

Remove 9 screws (B) and then remove the Cover Bottom (35).

3 FRONT PANEL ASSEMBLY REMOVAL

1. Remove the Cover Top (61), referring to the previous step 1.
2. Remove the Card cable from wafer (CP502) on the Volume P.C.Board (PCB6).
3. Remove the Card cable from wafer (CP802) on the Dolby P.C.Board (PCB8).
4. Remove the Card cable from wafer (CP803) on the Tuner P.C.Board (PCB2).
5. Disconnect (CP401 and CP581) from the Dolby P.C.Board (PCB8).
6. Disconnect (CP291) from the Tuner P.C.Board (PCB2).
7. Disconnect (CP402) from the Main P.C.Board (PCB1).
8. Disconnect (CP801) from the Power Supply P.C.Board (PCB3).
9. Remove 4 screws (C), 4 screws (A) and then remove the Front Panel Assembly (AA).

4 HEADPHONE P.C.BOARD (PCB9) REMOVAL

1. Remove the Front Panel Assembly (AA), referring to the Previous step 3.
2. Remove 2 screws (E) and then remove the Headphone P.C.Board (PCB9).

5 VOLUME P.C.BOARD (PCB6) REMOVAL

1. Remove the Front Panel Assembly (AA), referring to the Previous step 3.
2. Pull out the Volume Knob (5) with LED P.C.Board (PCB10).
3. Remove the Hex Nut from the volume-motor to remove the Volume P.C.Board (PCB6).
4. Remove 2 screws (F) and then remove the Volume P.C.Board (PCB6).

6 TONE P.C.BOARD (PCB5) REMOVAL

1. Remove the Front Panel Assembly (AA), referring to the Previous step 3.
2. Pull the Bass, Treble, Balance Knobs (7).
3. Remove the Hex Nuts from the variable resistors (19, 20).
4. Remove 4 screws (G) and then Tone P.C.Board (PCB5).

7 FRONT P.C.BOARD (PCB7) REMOVAL.

1. Remove the Front Panel Assembly (AA), referring to the Previous step 3.
2. Remove 11 screws (H) and then remove the Front P.C.Board (PCB7).

8 SUB-WOOFER P.C.BOARD (PCB11) REMOVAL

1. Remove the Cover Top (61), referring to the previous step 1.
2. Disconnect (CP903) on the Tuner P.C.Board (PCB2).
3. Remove 2 screws (K) and then remove the Sub-Woofers P.C.Board (PCB11).

9 TUNER P.C.BOARD (PCB2) REMOVAL

1. Remove the Cover Top (61), referring to the previous step 1.
2. Remove the Card cable from wafer (CP803) on the Tuner P.C.Board (PCB2).
3. Disconnect (CP102, CP103, CP104, CP105, CP291, CP501, CP704, CP901, CP902 and CP903) on the Tuner P.C.Board (PCB2).
4. Remove 2 screws (I), 6 screws (J) and then remove the Tuner P.C.Board (PCB2).

10 DOLBY P.C.BOARD (PCB8) REMOVAL

1. Remove the Cover Top (61), referring to the previous step 1.
2. Remove the Front Panel Assembly (AA), referring to the previous step 3.
3. Remove the Card cable (CN501) on the Dolby P.C.Board (PCB8).
4. Disconnect (CP601) from the Dolby P.C.Board (PCB8).
5. Unjoin 2 Fasteners (37) for remove the Dolby P.C.Board (PCB8).

11 SURROUND P.C.BOARD (PCB4) REMOVAL

1. Remove the Cover Top (61), referring to the previous step 1.
2. Do Steps 2, 3 and 10.
3. Disconnect (CP602) from the Power Supply P.C.Board (PCB3).
4. Remove 6 Screws (L) and then remove the Chassis Front (36).
5. Remove 2 screws (M) and then remove the Surround P.C.Board (PCB4).

12 CHASSIS BACK REMOVAL

1. Remove the Cover Top (61), referring to the previous step 1.
2. Do Steps 2, 3, 10, 11.

3. Unsolder 2 leads of the AC Cord (59) from neutral and live on the Power Supply P.C.Board (PCB3).
4. Remove 20 screws (N) and then remove the Chassis Back (57).

13 MAIN P.C.BOARD (PCB1) REMOVAL

1. Remove the Cover Top (61), referring to the previous step 11.
2. Do Steps 2, 3 and 12.
3. Unsolder all leads of Q262L/R/C, Q263L/R/C, Q270L/R/C and IC241 from copper track on the Main P.C.Board (PCB1).
4. Disconnect (CP241) from the Power Transformer (62).
5. Remove 2 screws (O) and then remove the Main P.C.Board (PCB1).

14 POWER SUPPLY P.C.BOARD (PCB3) REMOVAL

1. Remove the Cover Top (61), referring to the previous step 11.
2. Disconnect (CP801, CP703, CP602, CP101, CP701 and CP702) from Power Supply P.C.Board (PCB3).
3. Disconnect (CP704) from the Tuner P.C.Board (PCB2).
4. Unsolder 2 leads of the AC Cord (59) from neutral and live on the Power Supply P.C.Board (PCB3).
5. Remove 4 screws (P) and then remove the Power Supply (PCB3).

TROUBLESHOOTING

Symptom	Cause and Remedy
Amplifier inoperative (FL indicator does not light)	A) Faulty AC power cord. Replace. B) Defect the power switch. Replace. C) Broken wire in the power transformer. Replace the power transformer. D) Blown power Replace the fuse.
Fuse blows when power is turned on.	A) Defective power transformer. Replace. B) Short the primary or secondary of the transformer circuitry. Repair the trace. C) Damaged rectifier (D241 to D244) or damaged trans (Q262 and Q263). Replace the defective component(s). D) Short circuit in the amplifier circuit. Repair the short.
Power indicator lights but no sound from both channels	A) Speaker switch 1 or 2 defective. Replace the defective switch (es). B) Defect in transistor Q262L/R, Q263L/R on the Main Amp Board. Repair the shorted component(s) in the amplifier circuit.
Speaker A inoperative	A) Speaker switch A defective. Replace
Speaker B inoperative	A) Speaker switch B defective. Replace.
Speaker works normally but headphones inoperative	A) Headphone plug does not mate with jack. Replace the jack. B) Defective resistors R295L/R Replace.

Symptom	Cause and Remedy
PHONO input inoperative	A) Poor contact in phono input jack. Repair or replace the jack. B) Defective phono switch or IC106. Replace.
LOUDNESS has no effect	A) Defective loudness switch. Replace. B) Defective resistor R301L/R, C301L/R and C302L/R Replace the defective component(s).
Bass control has no effect	A) Variable resistor BASS defective. Replace. B) Defective R416L/R, R417L/R, R418L/R, C414L/R, C415L/R Replace the defective component(s).
Treble control has no effect	A) Variable resistor TREBLE defective. B) Defective C417L/R, C418L/R, R419L/R, R420L/R Replace the defective components(s).
Noise Volume control	A) Defective IC301. Replace. B) Defective capacitor C304 or C305 Replace the defective capacitor(s).
Remote Control Unit inoperative	A) Weak Battery. Replace. B) Defective. Replace. C) Defective IC801 or Sensor 801 (CPU Board) or IC01. Replace.

GENERAL UNIT PARTS LIST

Ref. No.	Description	Mfr. Part No.	Q'ty	Version
CABINET AND CHASSIS				
1	Panel, Front	048602019322	1	
2	Body, Front	8521008910	1	
3	Window, FL	048553020111	1	
4	Filter, FL	048535042611	1	
5	Knob, Volume	048643006711	1	
6	Indicator, Volume	8555049210	1	
7	Knob, Rotary	048545126311	3	
8	Button, Power	048543061011	1	
9	Light Shield	8535042910	1	
10	Indicator, Power	8555048710	1	
11	Button, Speaker	048545124111	3	
12	Bracket, Shield	8165148210	1	
13	Button, Source	048543060911	1	
14	Sponge	8715020730	1	
15	Button, Seesaw	048543060811	1	
16	Shield Fence	8163114510	1	
17	Button, Tuning	048543059711	1	
18	Volume Rotary (Bass/Treble)	3208049510	2	
19	Volume Rotary (Balance)	3208052010	1	
20	Jack, RCA, 3P	4438109710	1	
21(SW301)	Switch, Push	4628059610	1	
22(VR301)	Volume, Motor	3228019410	1	
23(SW801)	Switch, Push	4628054410	1	
24(SW291)	Switch, Push	4628043810	1	
25(SW282)	Switch, Push	4628049210	1	
26	Jack, Phone	4438005010	1	
27	Switch, Tact	4658003710	38	
28(SEN801)	Remote Sensor, TFMT5380 (38 kHz)	2408005001	1	
29(FIP801)	FIP, 12 LM 8, FL Display	2328130301	1	
30	Frame Right	6122632210	1	
31	Foot, ABS, Gold, Hot stamping	046033102511	2	
32	Foot, ABS, Black	6033102510	2	
33	Cover Bottom	6122418610	1	
34	Chassis, Front	6122214610	1	
35	Fastener	6528300110	2	
36	Heatsink Power	7502008310	1	
37	Bracket, Heat Sink	6505135910	1	
38	Clamp, Wire	6525002210	2	
39	Bracket, Heat Sink	6505135810	1	
40	Bracket, PCB	6505130010	2	
41	Frame left	6122632110	1	
42	Heatsink, Regulator TR.	7505206220	1	
43	Heatsink, Regulator TR.	7505202410	5	
44	Jack, RCA, 2P	4438108510	1	
45	Jack, RCA, 6P	4438108710	2	
46	Jack, RCA, 3P	4438108810	4	
47	Jack, RCA, 2P, Yellow	4438114210	1	
48	Terminal Speaker, 8P	4408105810	1	
49	Terminal Speaker, 4P	4408105410	1	
50	Terminal Speaker, 2P	4408108710	1	
51	Jack, Multiroom	4438006510	2	
52	Jack, RCA, 4P	4438108610	2	
53	Chassis, Back	046102041352	1	EUROPE
(53)	Chassis, Back	046102041322	1	US/CANADA
54	Ground Terminal	4408103720	1	
55	Plug, Mono	4328208510	2	
56	⚠ Cord, AC Power	4308002310	1	
57	Stopper, AC Cord	6518000111	1	EUROPE
(57)	Stopper, AC Cord	6518000710	1	US/CANADA
58	Cover Top, SECC, Black	046122022611	1	
59	⚠ Power Transformer, 230 V, 50 Hz	2828001117	1	EUROPE
(59)	⚠ Power Transformer, 120 V, 60 Hz	2828009967	1	US/CANADA
60	Heatsink (H:30), Regulator TR.	7505206210	1	
61	Tie locking	6528002810	1	
62	⚠ Outlet, 1P	4448103610	1	EUROPE
(62)	⚠ Outlet, 3P	4448102910	1	US/CANADA
63	Jack RCA, 2P	4438111510	1	
HARDWARE KIT				
S1	Screw #2 BTC 3 X 8 B	8109230083	37	
S2	Screw WSAM 4 X 8 B	8159440083	10	
S3	Screw #2 BTC 3 X 6 B	8109230063	5	
S4	Screw #2 FTC 3 X 8 B	8129230083	9	
S5	Screw #2 WPTC 3 X 8 Y	8159230081	9	
S6	HEX MSPW 3 X 12 Y	8099130121	6	
S7	HEX MSPW 3 X 16 Y	8099130161	2	
S8	Screw, Heatsink	8195000310	4	
S9	Screw #1 PTC 3 X 10 B	8119130103	21	
S10	Screw Ground	8155000710	2	
MISCELLANEOUS				
	Card Cable, 12P 450mm	4118612455	1	
	Card Cable, 15P 180mm	4118615189	1	
	Card Cable, 18P, 140mm	4118618149	1	
	Card Cable, 19P, 450mm	4118619459	1	
	Ass'y Posistor	052438012202	1	
	Posistor, PTH9M04BE222TS2F33	2438012200	2	

PRODUCT SAFETY NOTICE

Each precaution in this manual should be followed during servicing. Components identified with the IEC symbol ⚠ in the parts list are of special significance to safety. When replacing a component identified with ⚠, use only the replacement parts designated, or parts with the same ratings of resistance, wattage or voltage that are designated in the parts list in this manual. Leakage-current or resistance measurements must be made to determine that exposed parts are acceptably insulated from the supply circuit before returning the product to the customer.

GENERAL UNIT

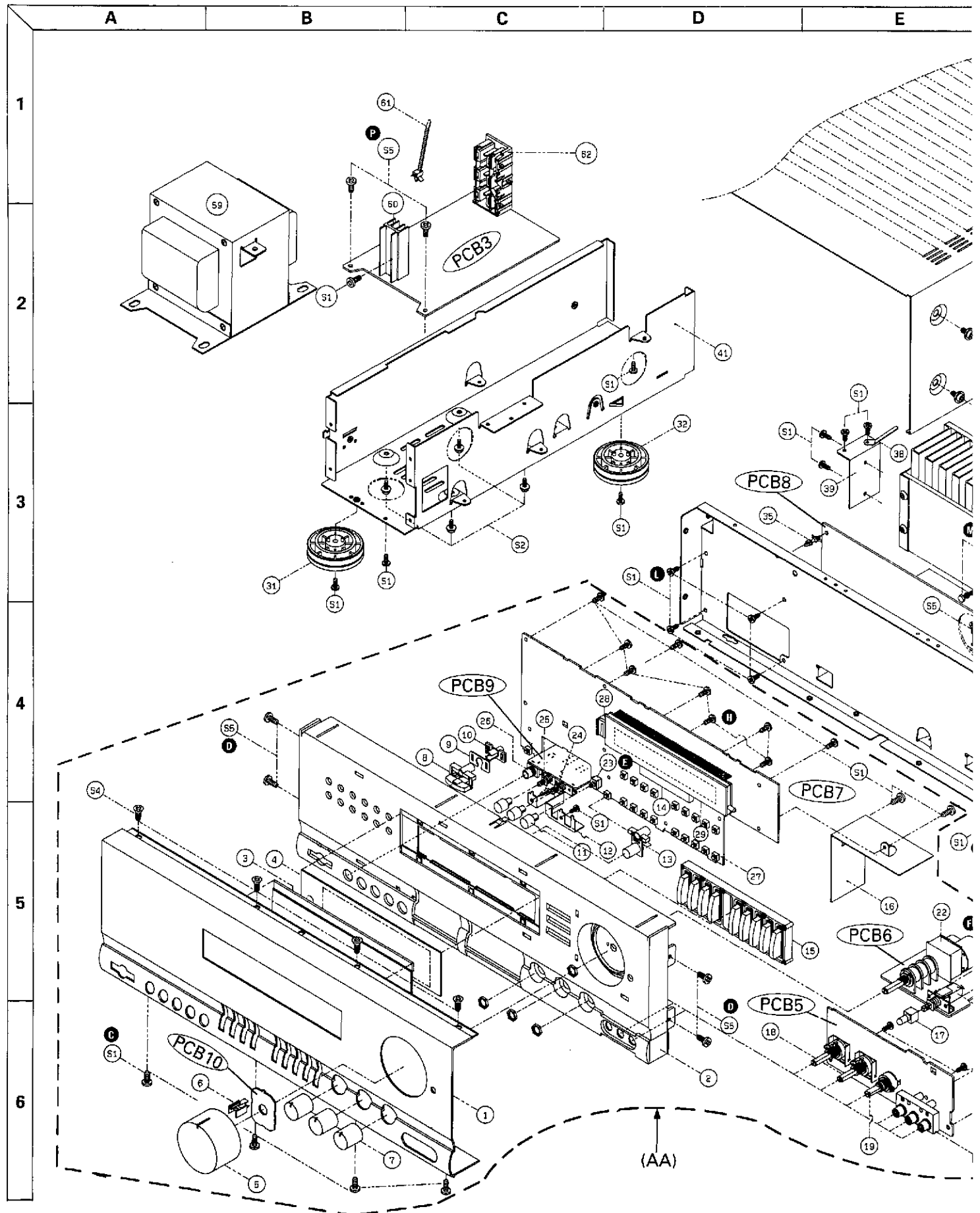

E	F		H	I
---	---	--	---	---

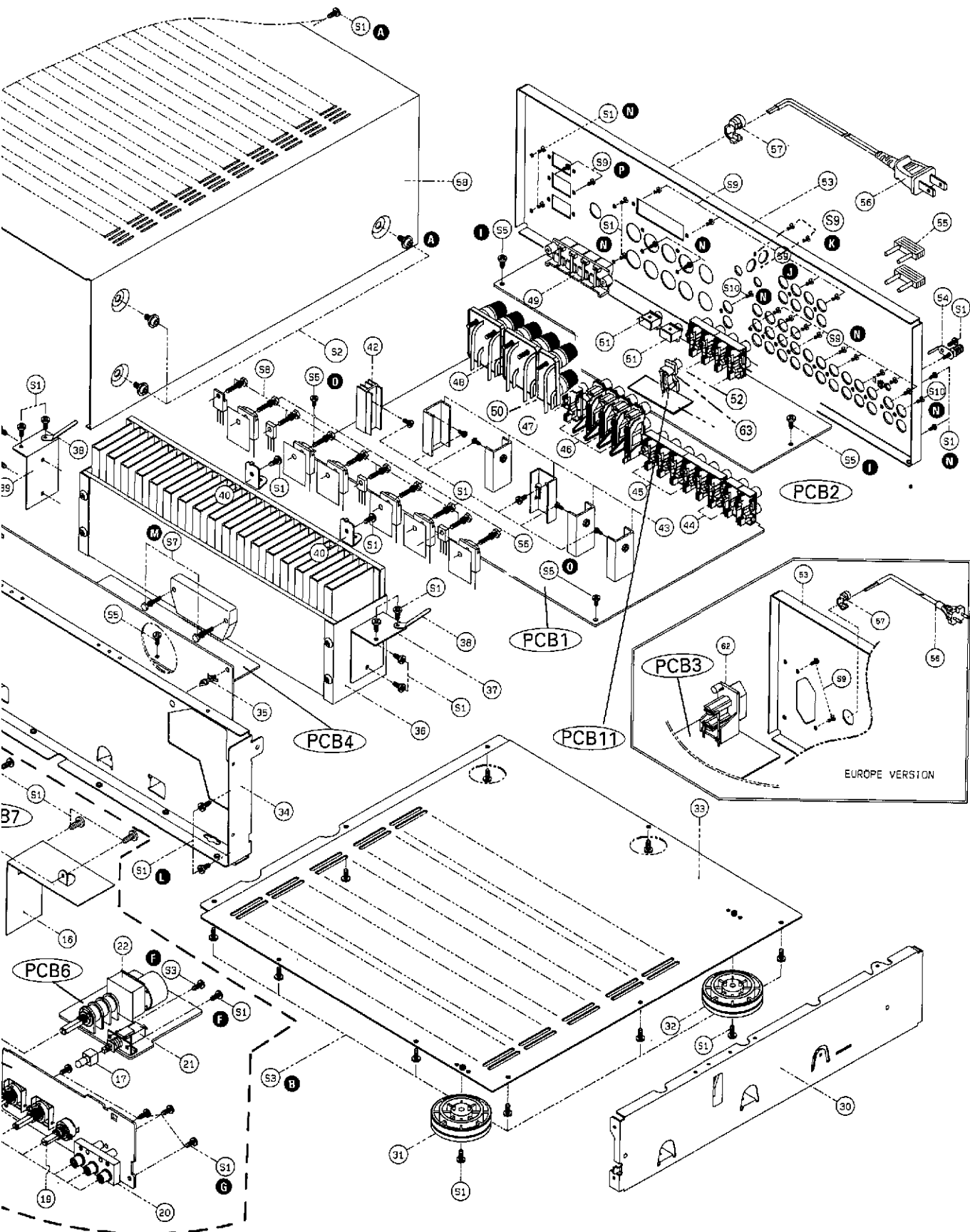

PRINTED CIRCUIT BOARDS

MAIN (PCB1)

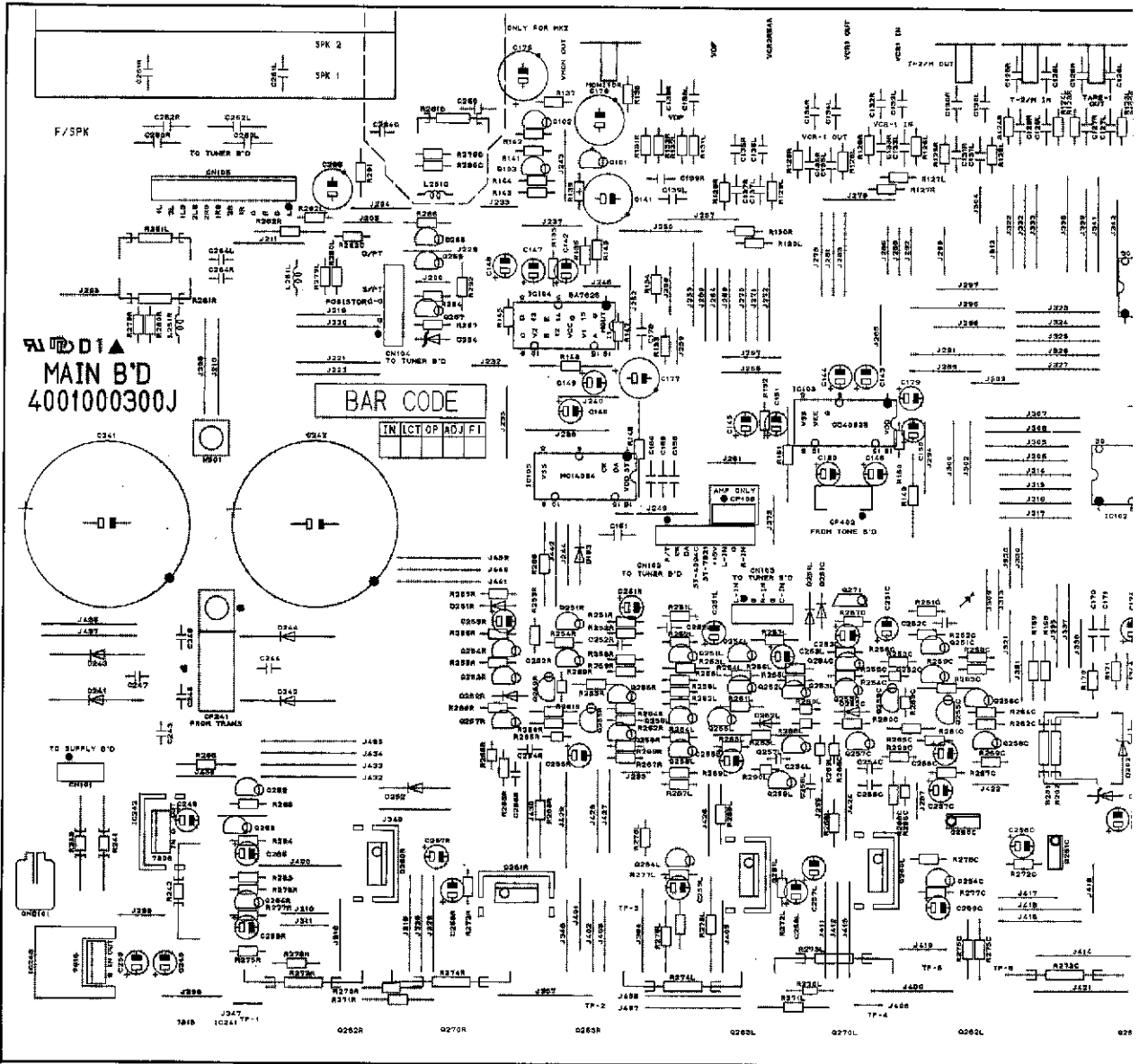

TUNER (PCB2)

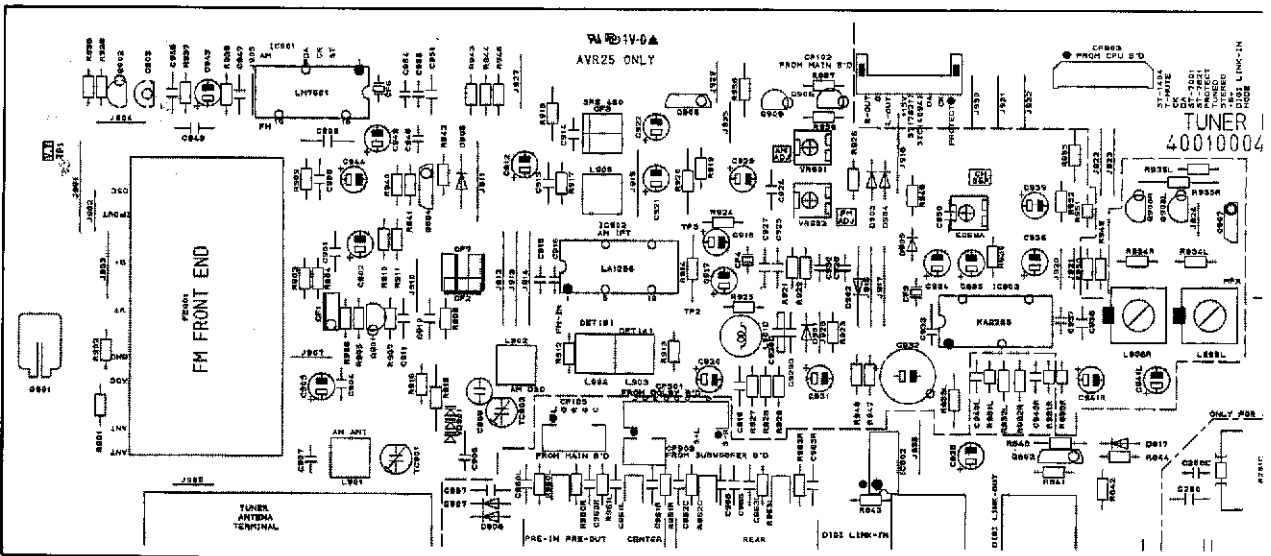

POWER SUPPLY (PCB3)

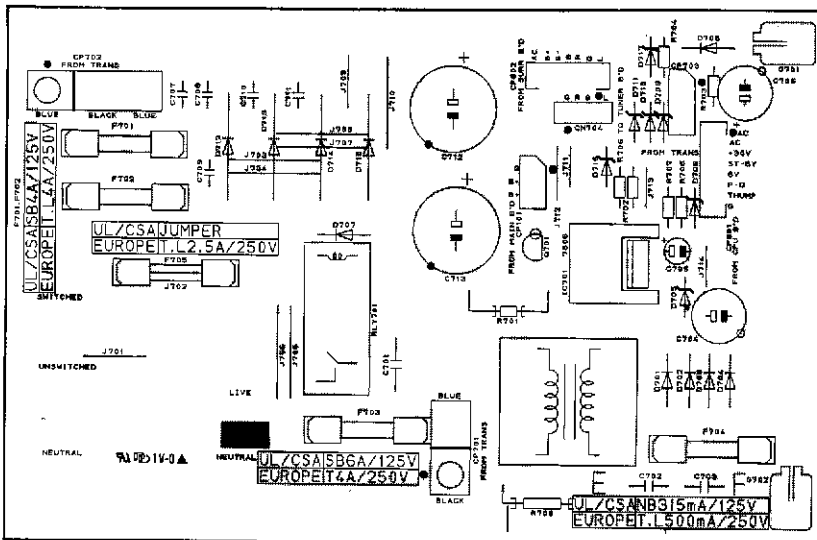

SURROUND (PCB4)

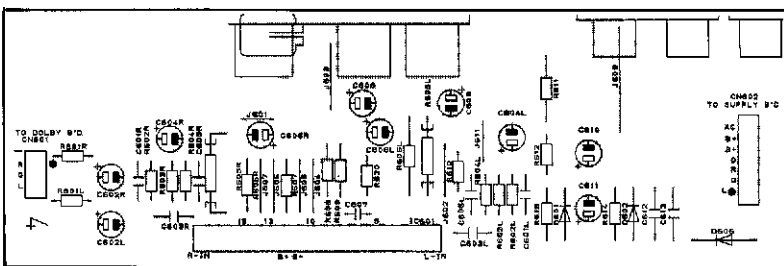

TONE (PCB5)

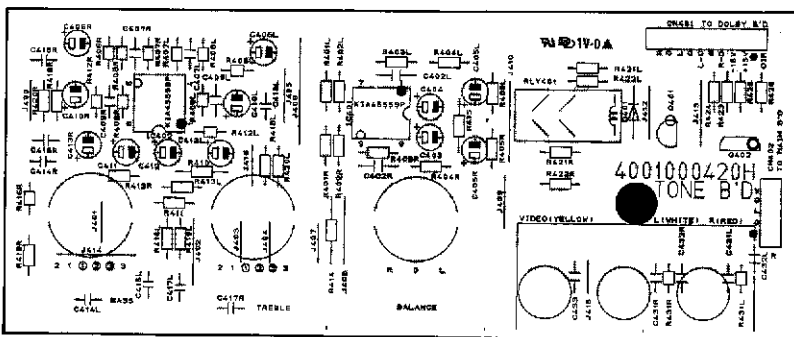

VOLUME (PCB6)

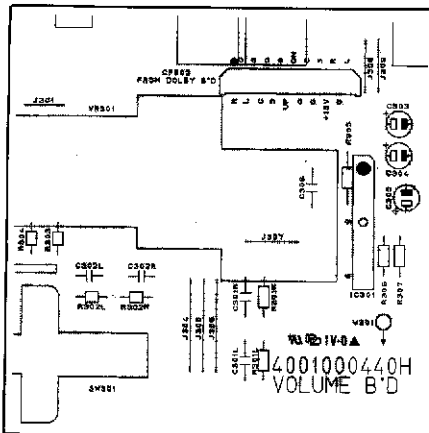

HEADPHONE (PCB9)

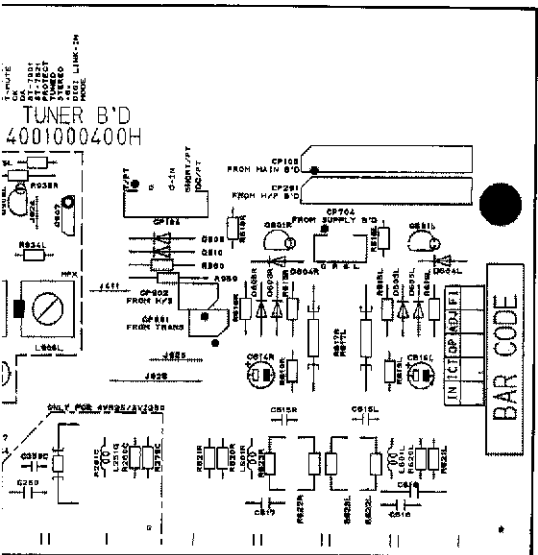
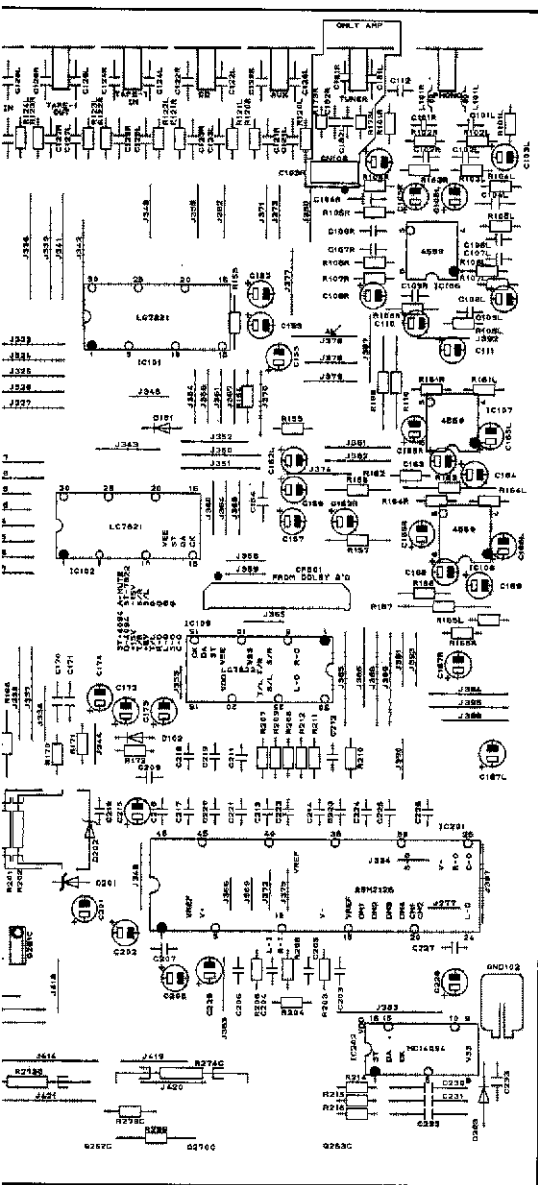
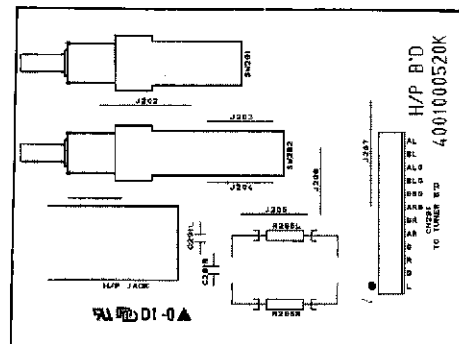

FRONT (PCB7)

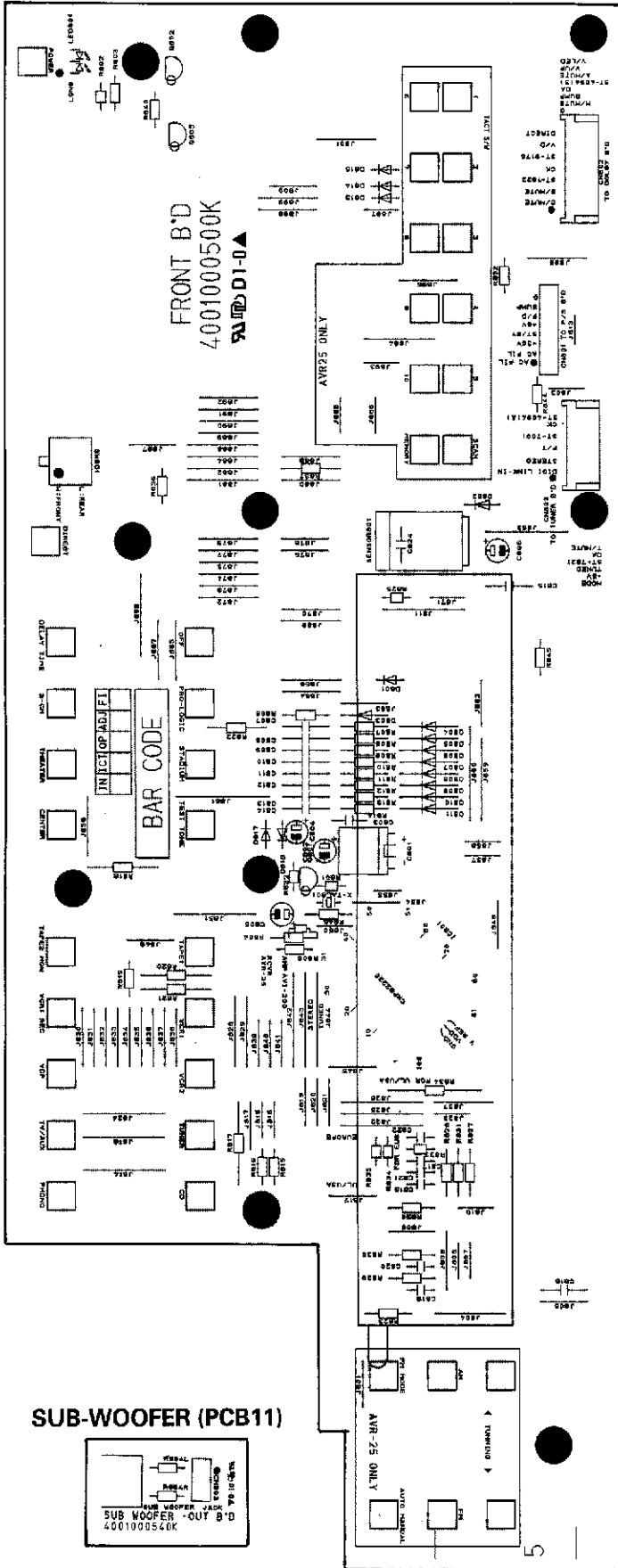

DOLBY (PCB8)

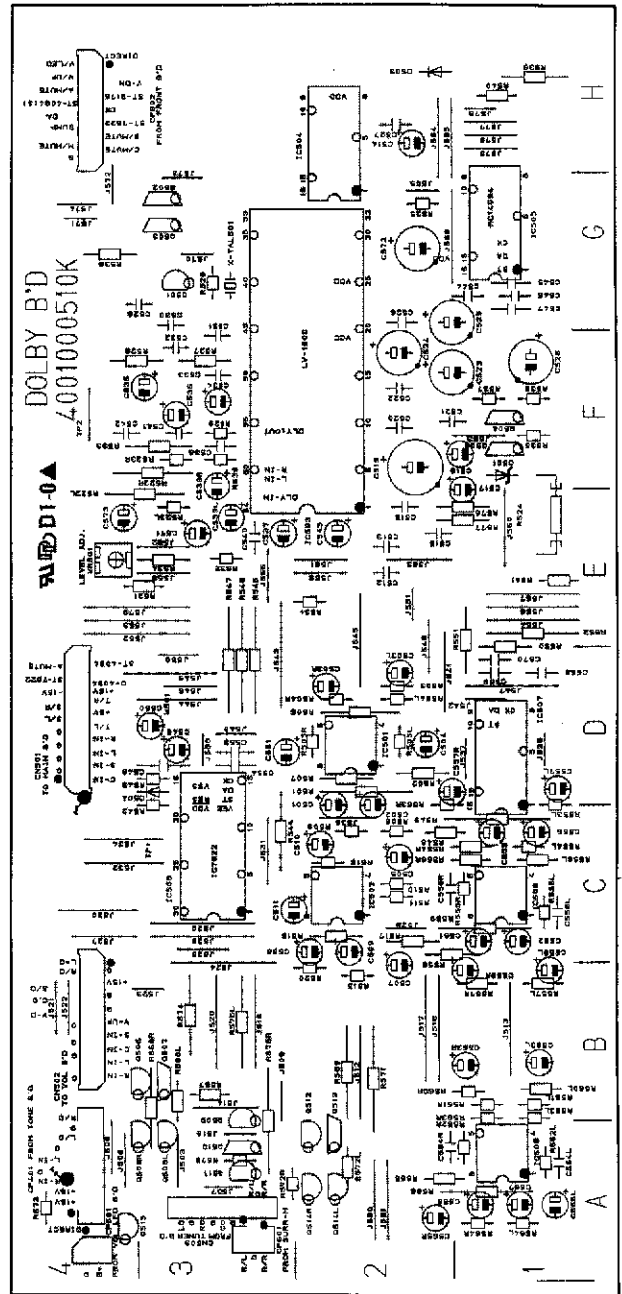

VOLUME LED (PCB10)

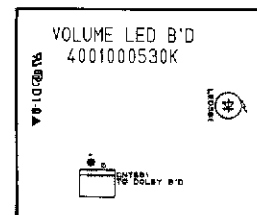

Ref. No.	Description		Mfr. Part No.	Q'ty	Version
R511	Carbon Film	4.7 kohm 1/5 W J	3069472970	1	
R515	Carbon Film	3.3 kohm 1/5 W J	3069332970	1	
R516/R517	Carbon Film	100 ohm 1/5 W J	3069101970	2	
R519	Carbon Film	10 kohm 1/5 W J	3069103970	1	
R520	Carbon Film	100 kohm 1/5 W J	3069104970	1	
R521	Carbon Film	3.9 kohm 1/5 W J	3069392970	1	
R522/L/R	Carbon Film	6.8 kohm 1/5 W J	3069682970	2	
R523/L/R	Carbon Film	100 kohm 1/5 W J	3069104970	2	
R524	Metal Film	56 ohm 1 W J	3029560470	1	
R525	Carbon Film	56 ohm 1/5 W J	3069560970	1	
R526	Carbon Film	1 Mohm 1/5 W J	3069105970	1	
R527	Carbon Film	47 kohm 1/5 W J	3069473970	1	
R528	Carbon Film	3.3 kohm 1/5 W J	3069332970	1	
R529	Carbon Film	15 kohm 1/5 W J	3069153970	1	
R530	Carbon Film	8.2 kohm 1/5 W J	3069822970	1	
R531	Carbon Film	100 kohm 1/5 W J	3069104970	1	
R532	Carbon Film	39 kohm 1/5 W J	3069399970	1	
R533/R534	Carbon Film	8.2 kohm 1/5 W J	3069822970	2	
R535	Carbon Film	47 kohm 1/5 W J	3069473970	1	
R536	Carbon Film	5.6 kohm 1/5 W J	3069562970	1	
R537	Carbon Film	1 kohm 1/5 W J	3069102970	1	
R538	Carbon Film	10 kohm 1/5 W J	3069103970	1	
R539-R541	Carbon Film	1 kohm 1/5 W J	3069102970	3	
R542	Carbon Film	220 ohm 1/5 W J	3069221970	1	
R543	Carbon Film	100 kohm 1/5 W J	3069104970	1	
R544	Carbon Film	220 ohm 1/5 W J	3069221970	1	
R545-R547	Carbon Film	1 kohm 1/5 W J	3069102970	3	
R548/R549	Carbon Film	220 ohm 1/5 W J	3069221970	2	
R550-R552	Carbon Film	1 kohm 1/5 W J	3069102970	3	
R553/L/R	Carbon Film	680 ohm 1/5 W J	3069681970	2	
R554/L/R	Carbon Film	1 Mohm 1/5 W J	3069105970	2	
R555/L/R	Carbon Film	4.7 kohm 1/5 W J	3069472970	2	
R556/L/R	Carbon Film	1.5 kohm 1/5 W J	3069152970	2	
R557/L/R	Carbon Film	2 kohm 1/5 W J	3069202970	2	
R558/R559	Carbon Film	100 ohm 1/5 W J	3069101970	2	
R560/L/R	Carbon Film	680 ohm 1/5 W J	3069681970	2	
R561/L/R	Carbon Film	1 Mohm 1/5 W J	3069105970	2	
R562/L/R	Carbon Film	4.7 kohm 1/5 W J	3069472970	2	
R563/L/R	Carbon Film	1.5 kohm 1/5 W J	3069152970	2	
R564/L/R	Carbon Film	2 kohm 1/5 W J	3069202970	2	
R565/R566	Carbon Film	100 ohm 1/5 W J	3069101970	2	
R567	Carbon Film	2.2 kohm 1/5 W J	3069222970	1	
R568/L/R	Carbon Film	2.2 kohm 1/5 W J	3069222970	2	
R569-R571	Carbon Film	2.2 kohm 1/5 W J	3069222970	3	
R572/L/R	Carbon Film	2.2 kohm 1/5 W J	3069222970	2	
R573	Carbon Film	820 ohm 1/5 W J	3069821970	1	
R574	Carbon Film	1 kohm 1/5 W J	3069102970	1	
R575/L/R	Carbon Film	1 kohm 1/5 W J	3069102970	2	
R576/R577	Carbon Film	220 kohm 1/5 W J	3069224970	2	

MISCELLANEOUS

X-TAL501	Resonator, CST8.00MTW		3936131590	1	
VR501	Semi Fixed Resistor, 10 k (B)		3248010343	1	
W501	CTB 0135 LV DIAMOND DL B#16		4359855035	1	

PCB9 ASSEMBLY P.C. BOARD HEADPHONE

R285/L/R	RES, Metal Film	470 ohm 2 W J	3029471570	2	
C291/L/R	CAP, Ceramic Tub	560 pF 50 V J	3519561935	2	
CN291	Lead Assy, 12P, 350 mm		435112353401	1	
24(SW291)	Switch Push		4628043810	1	
25(SW292)	Switch Push		4628049210	1	
26	Jack, Phone		4436005010	1	

PCB10 ASSEMBLY P.C. BOARD VOLUME LED

CNT581	Lead Assy, 2P, 180 mm, 2.5 mm Pitch		4356102184	1	
LED581	LED, SLC-22VRS, Green		2306220324	1	

PCB11 ASSEMBLY P.C. BOARD SUB-WOOFER

CN903	Lead Assy, 3P, 180mm		436203183332	1	
R964/L/R	RES, Carbon Film	1 kohm 1/5 W J	3069102970	1	
63	Jack RCA, 2P		4436111510	1	

IC FUNCTIONAL BLOCK DIAGRAM

IC301 TA7291S

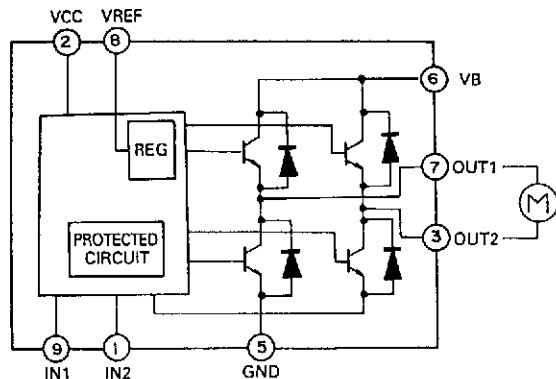

IC104 BA7625

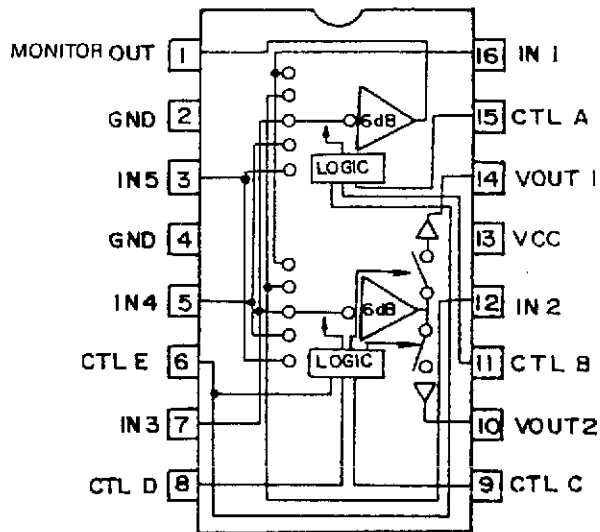

IC103 GD4052B

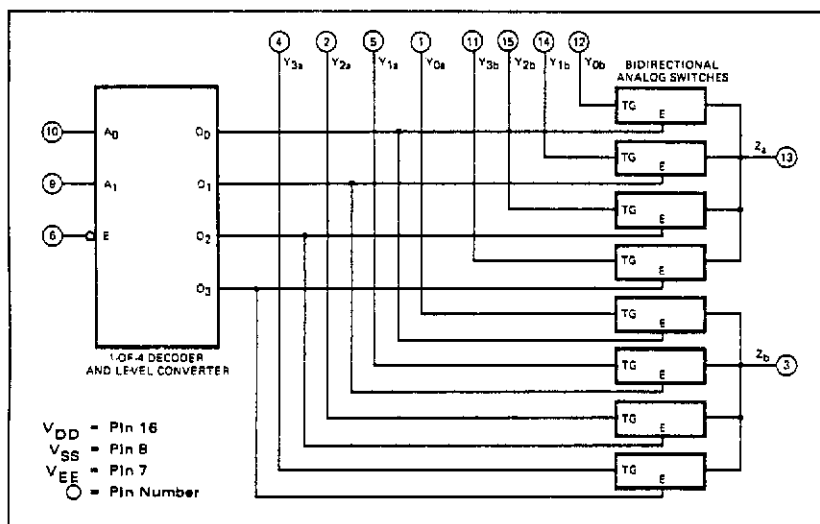

IC106, IC107, IC108, IC401, IC402
IC501, IC502, IC508, IC509
KIA4559/KIA75559P

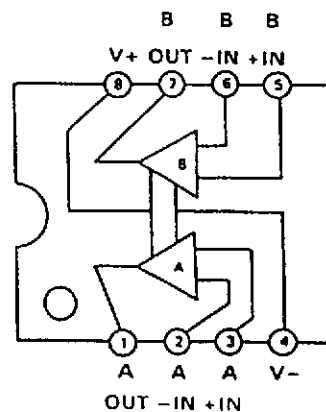

IC243 GL7915

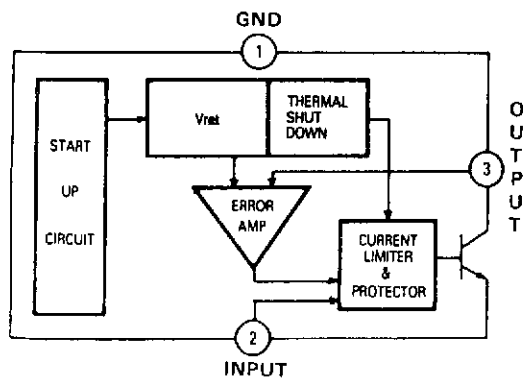

IC242, IC701 GL7806
IC241 GL7815

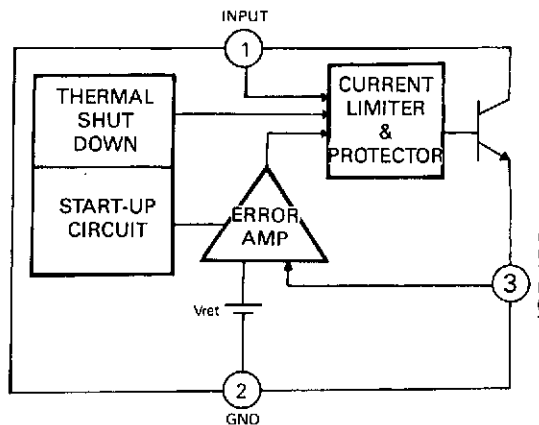

IC507 TC9176P

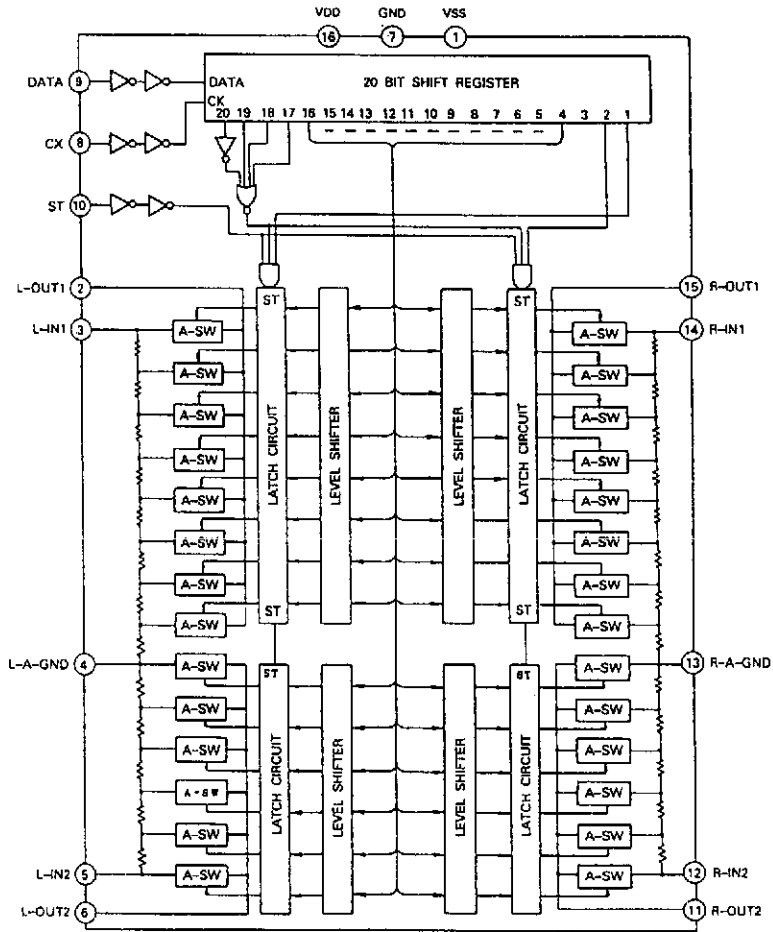

IC105, IC202, IC505 MC14094

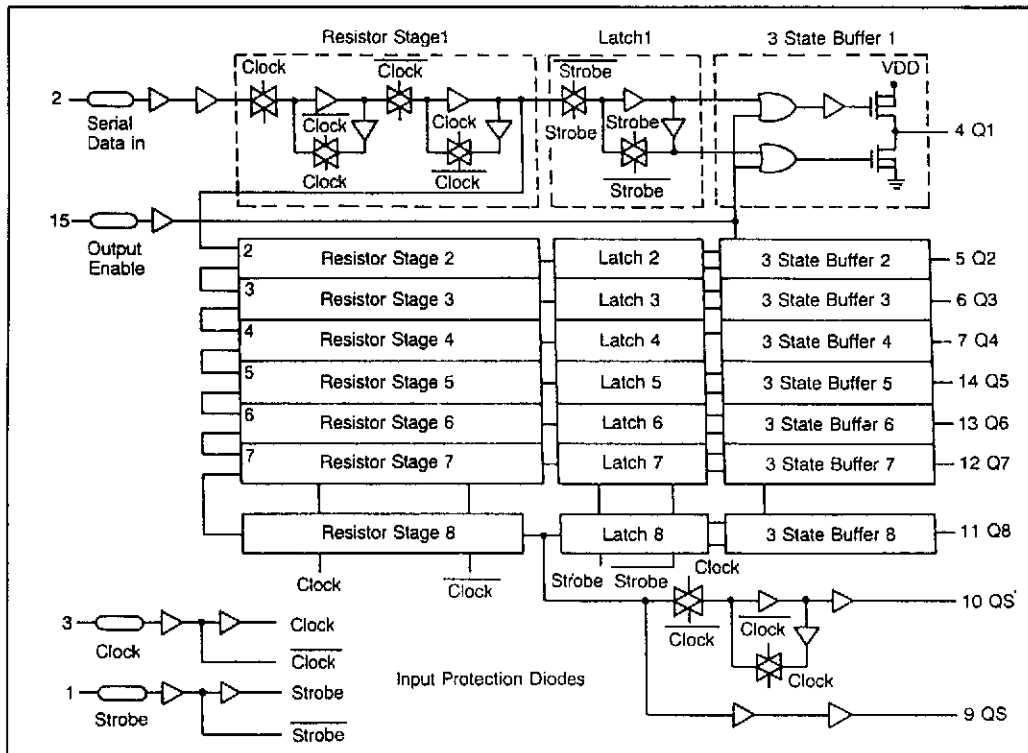

IC601 STK4132II

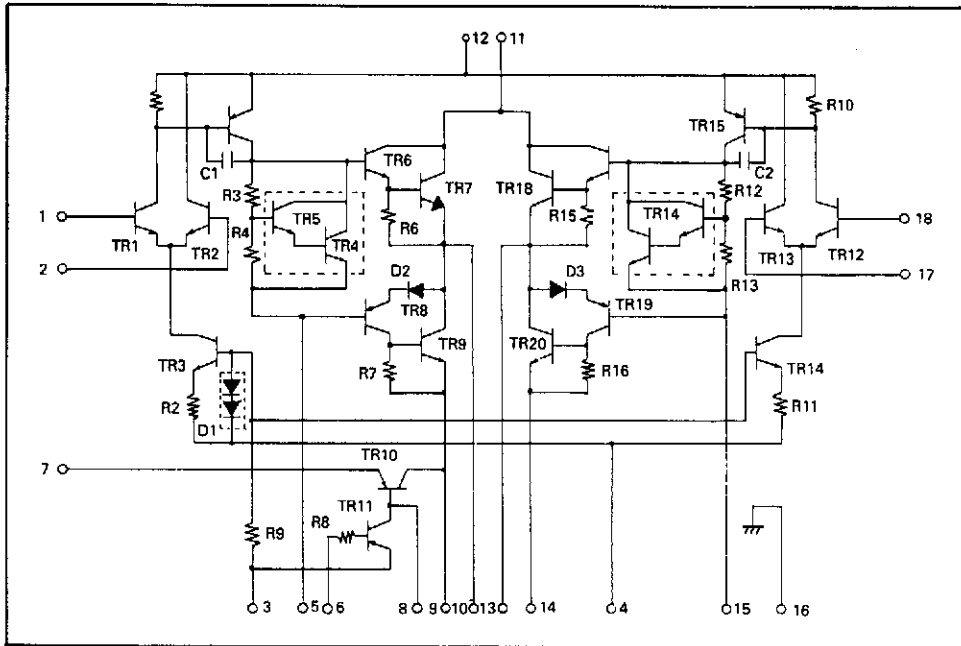

IC503 LV1000NA

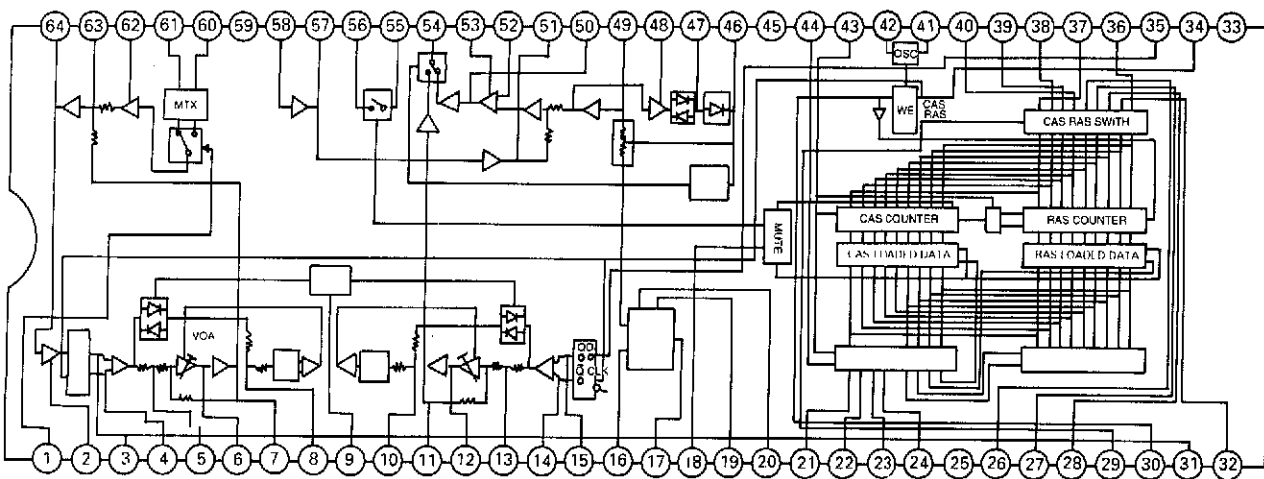

IC101, IC102 LC7821

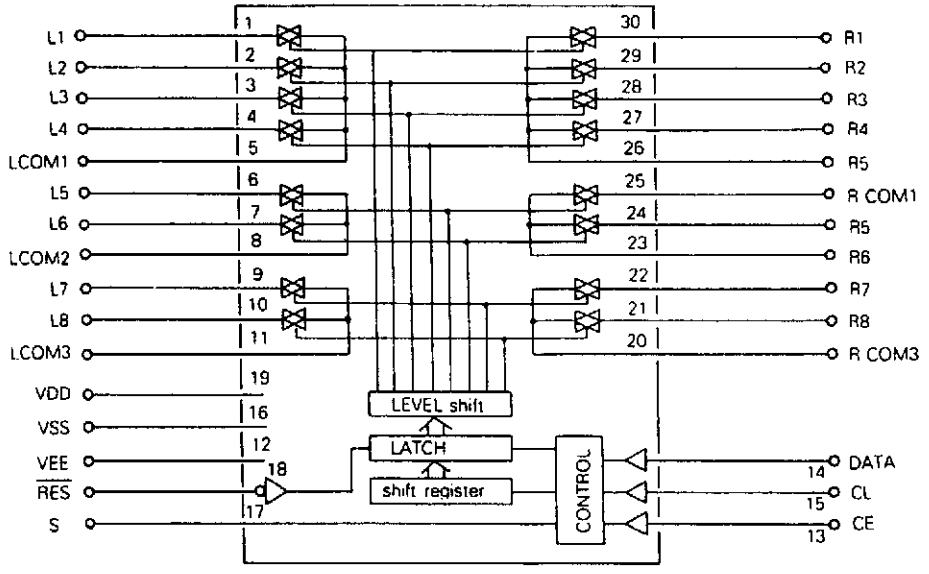

IC109, IC506 LC7822

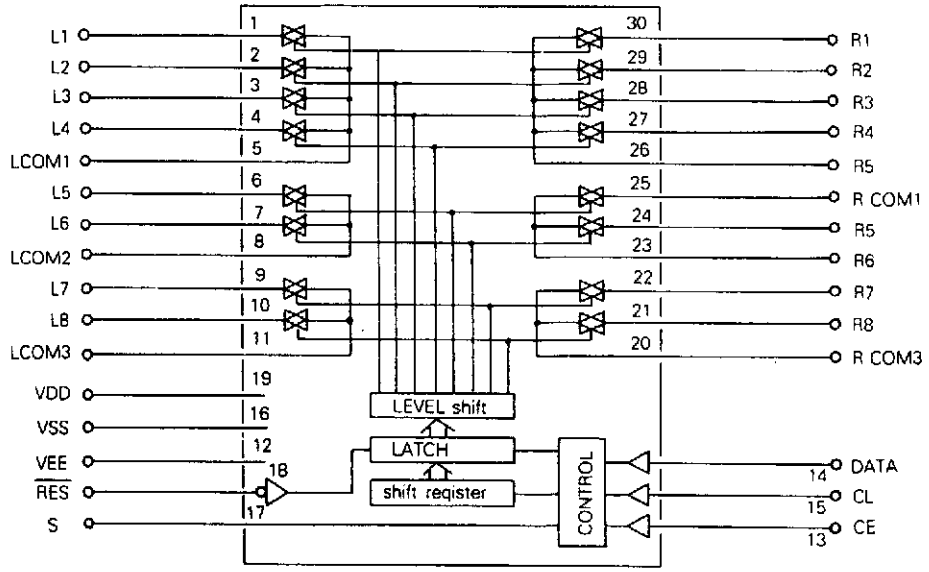

IC201 SSM2126A

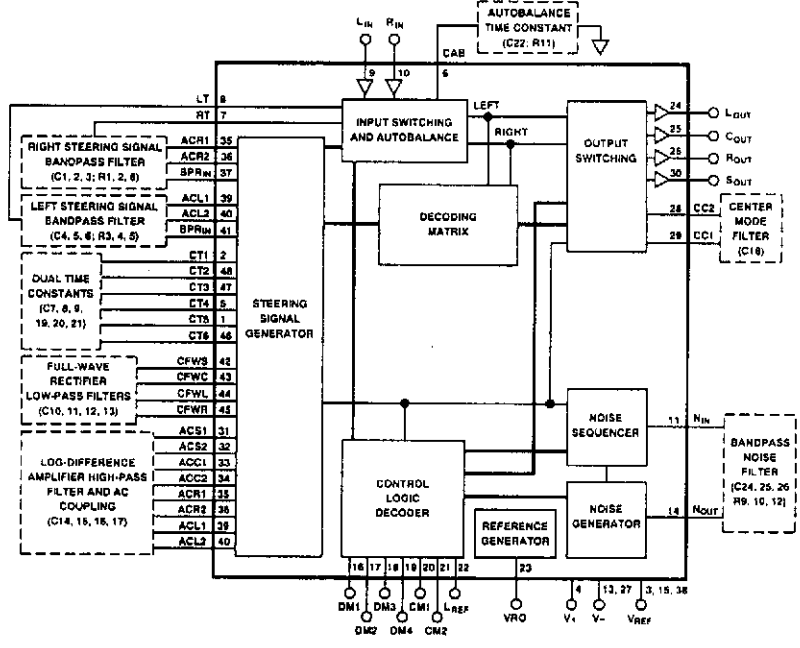

SCHMATIC DIAGRAMS I

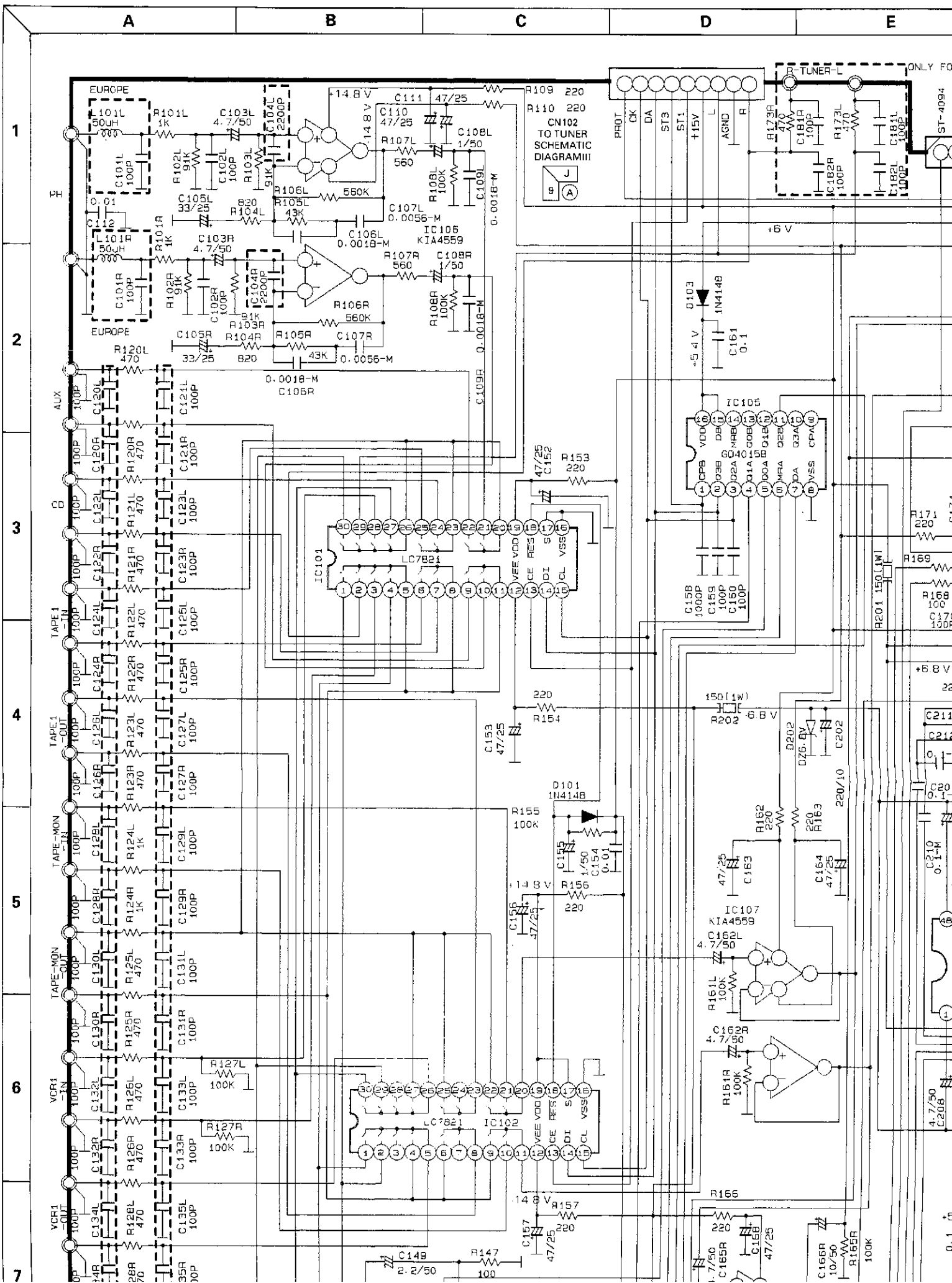

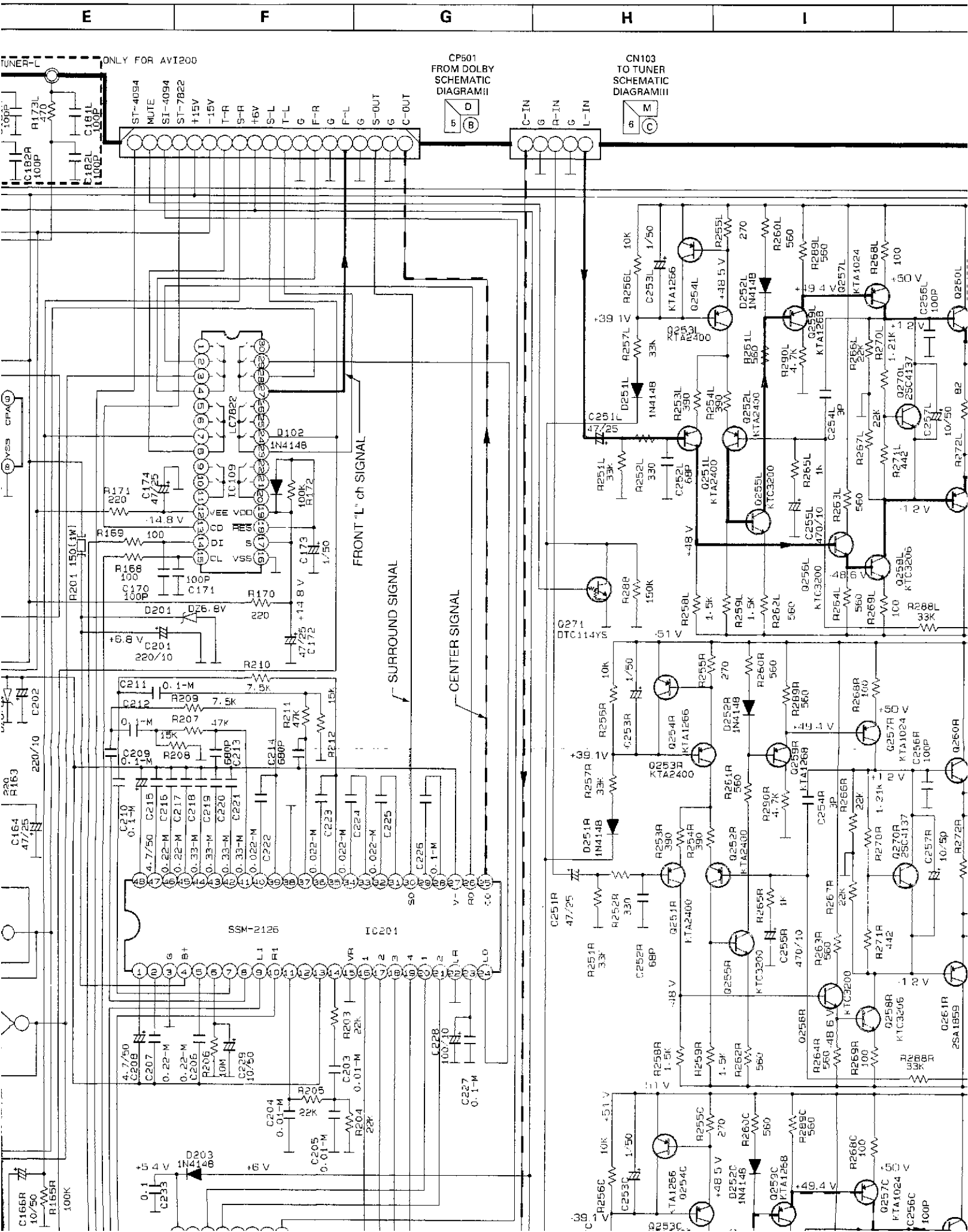

E

F

G

H

I

TUNER-L ONLY FOR AVI200

CP501 FROM DOLBY SCHEMATIC DIAGRAM II

CN103 TO TUNER SCHEMATIC DIAGRAM III

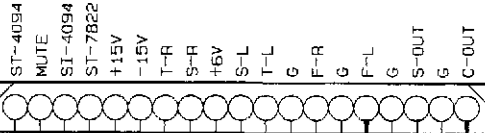

FRONT "L" ch SIGNAL

SURROUND SIGNAL

CENTER SIGNAL

SSM-2126

IC201

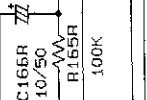

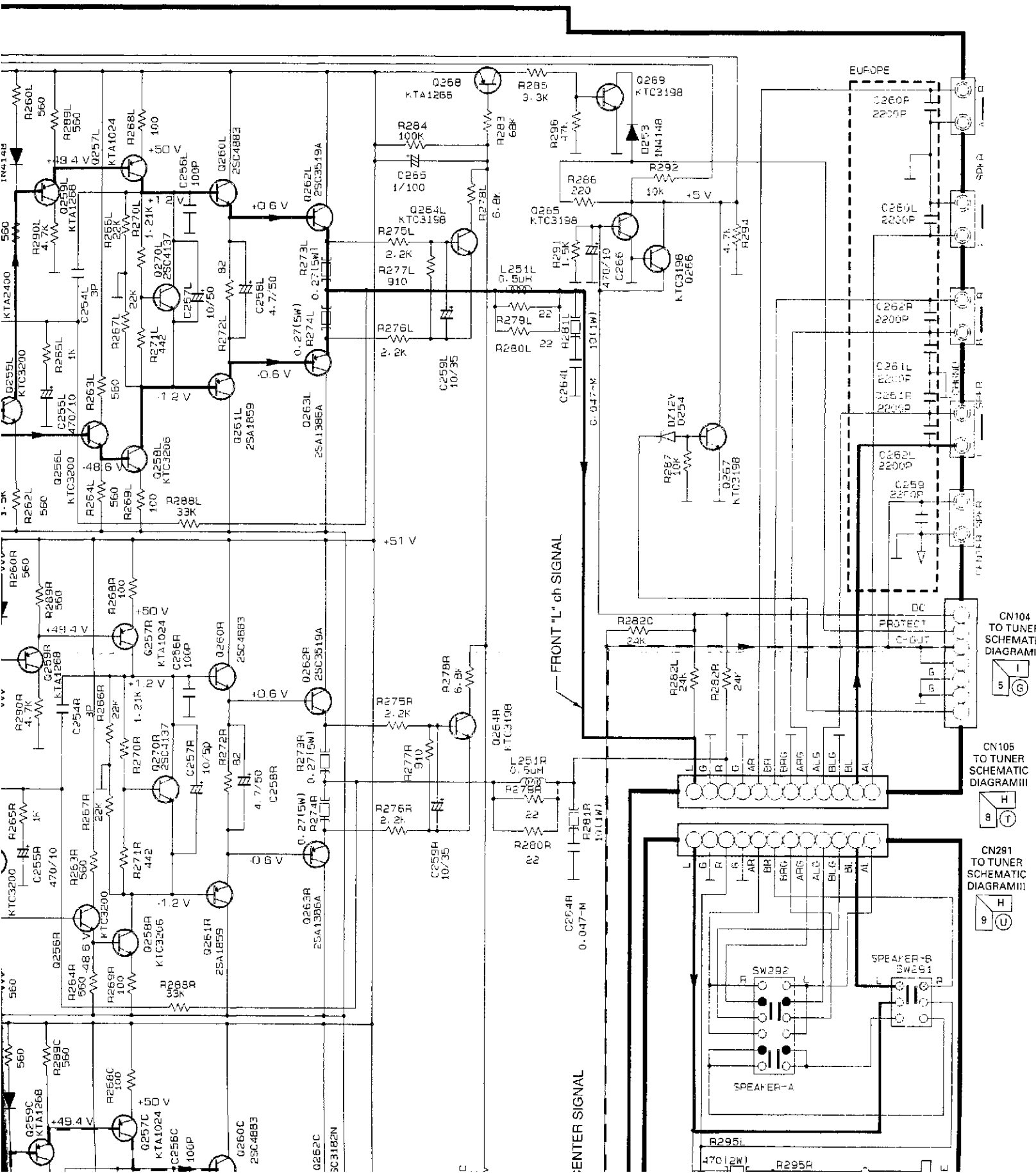

CN104 TO TUNER SCHEMATIC DIAGRAM II
 5 (G)
 CN105 TO TUNER SCHEMATIC DIAGRAM III
 8 (T)
 CN291 TO TUNER SCHEMATIC DIAGRAM III
 9 (U)

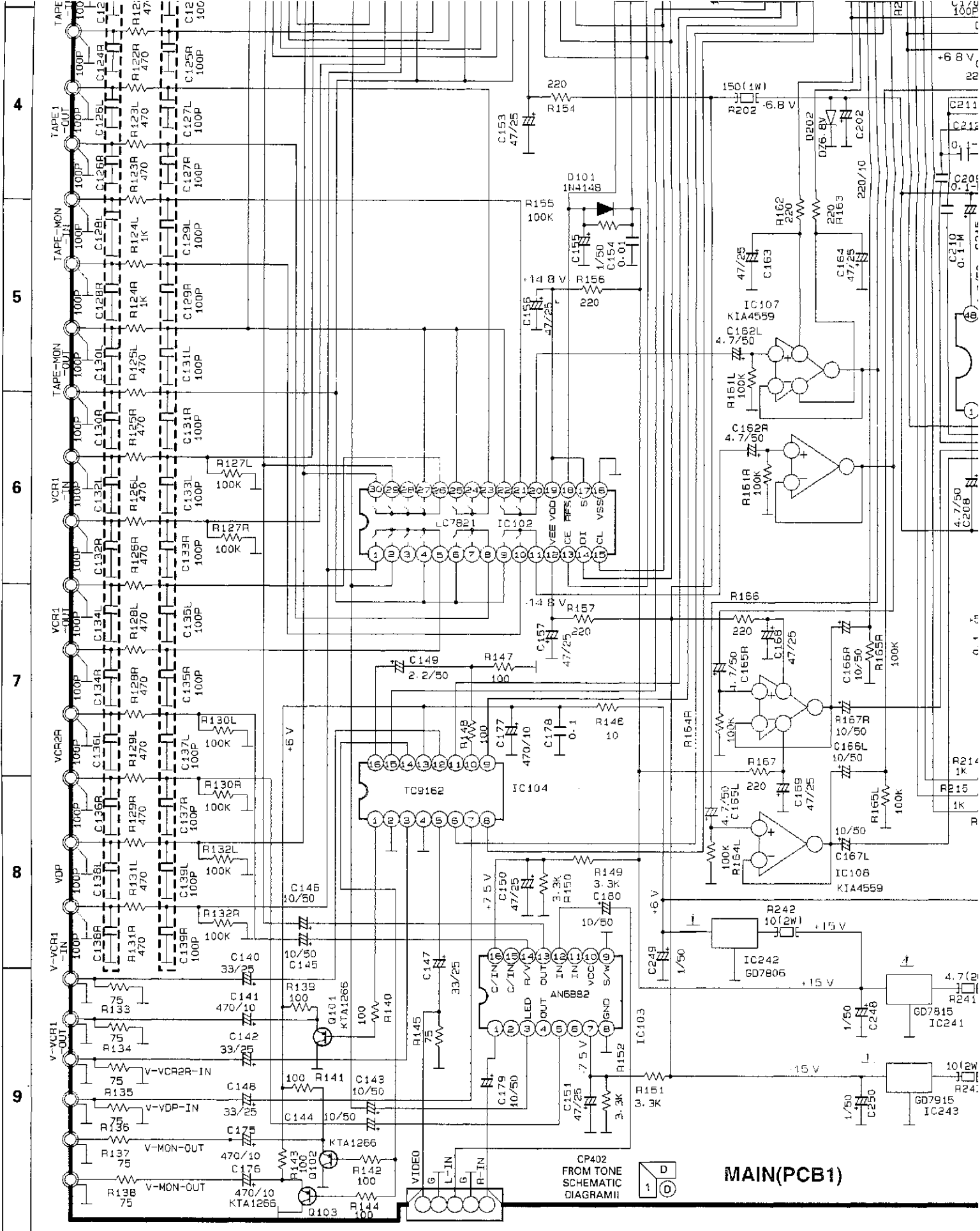

MAIN(PCB1)

PIN CONNECTION DIAGRAM OF TRANSISTORS AND DIODES

<p>2SA1265N 2SC3182N 2SC3519A 2SA1859A</p>	<p>2SC4137</p>	<p>DTA114YS DTC114YS</p>	<p>SPR-54MDW3 SLR-22VRS</p>	<p>ZENER PX6A03 IN5402 IN4003 IN4148</p>
--	----------------	------------------------------	---------------------------------	--

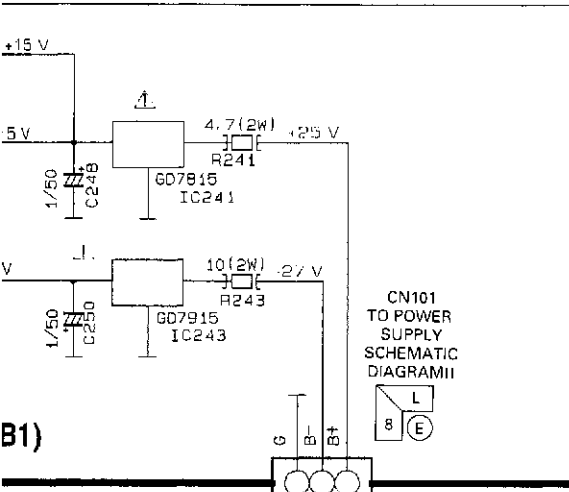
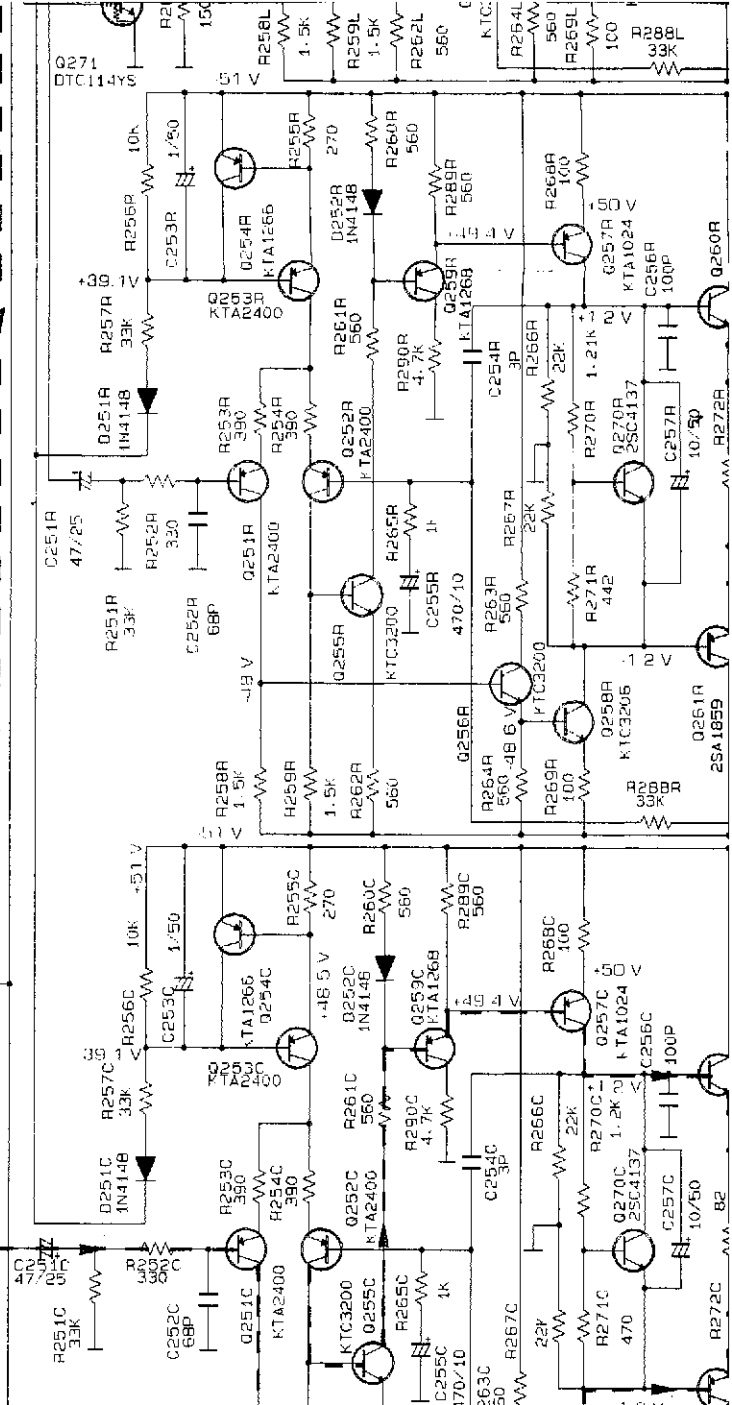
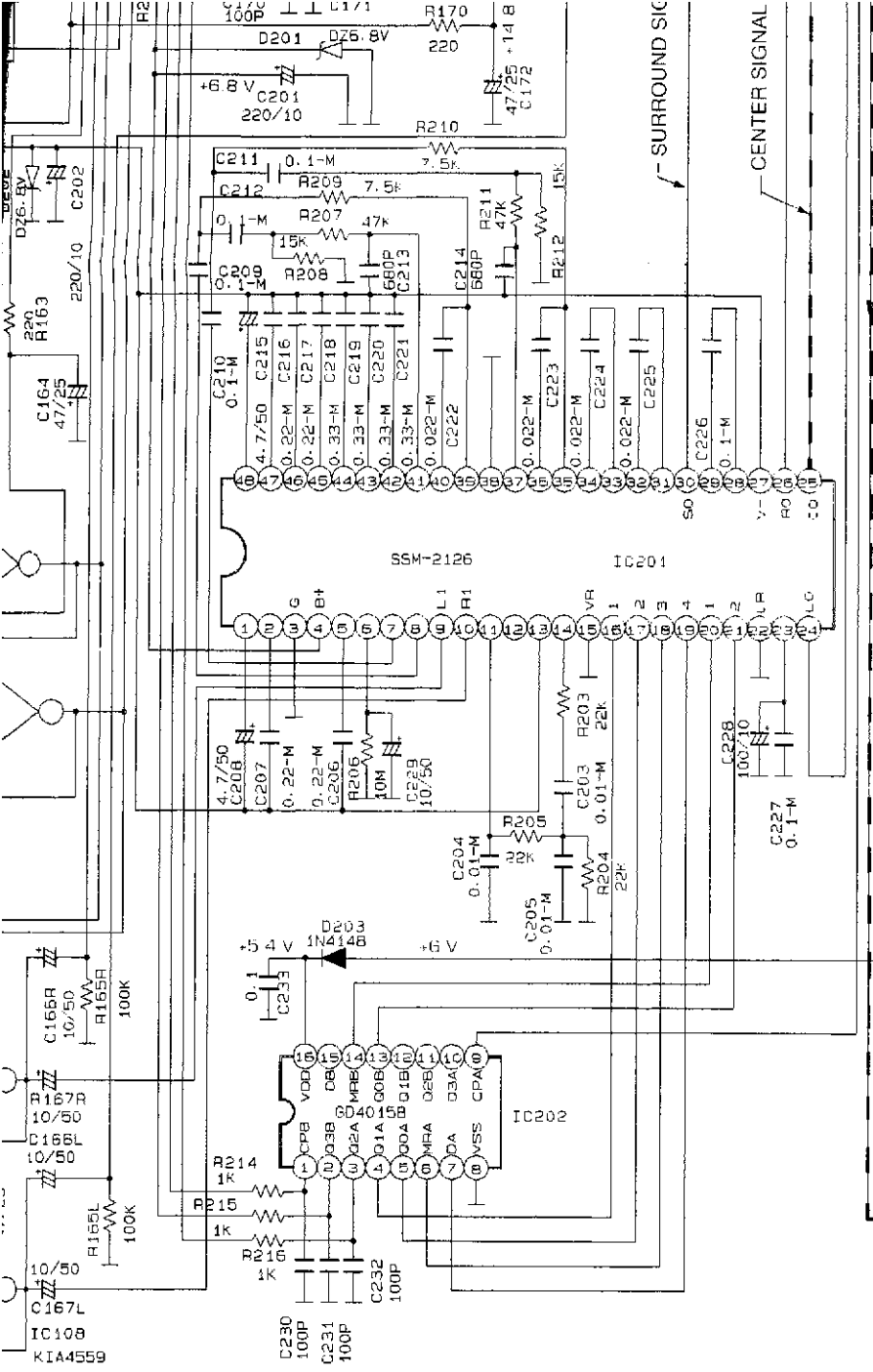



NOTES

1. Resistor values are indicated in ohms unless otherwise specified
(K=1,000 M=1,000,000)
2. Capacitor values are indicated in microfarads unless otherwise specified.
(p=micro-microfarads)

CAUTION
Safety precaution to be followed during servicing

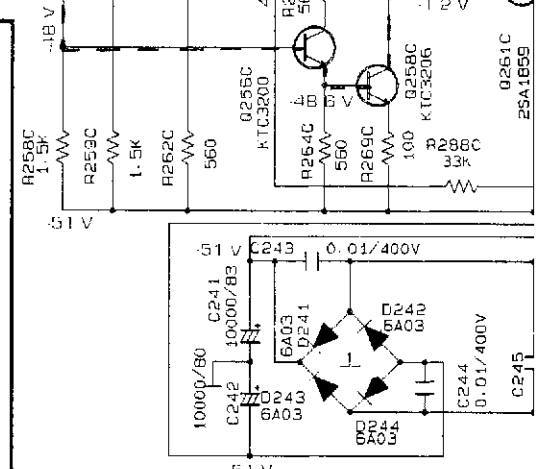
- 1) Since those parts marked with  are critical parts for safety, use only the one described in the parts list.
- 2) Before returning the set to the customer make appropriate leakage current or resistance measurements to determine the exposed parts are properly insulated from the supply circuit.

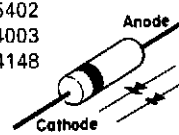
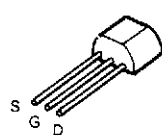
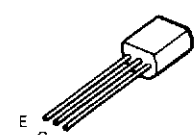
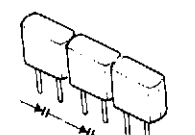
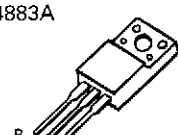

<p>ZENER PX6A03 IN5402 IN4003 IN4148</p> 	<p>2SK168</p> 	<p>KTA2400 KTD1302 KTC2240/KTC3200 KTC3198/KTC1815 KTC1923/KTC3194 KTA1266/KTA1015Y</p> 	<p>KV1236Z</p> 	<p>2SA1386A 2SC4883A</p> 	<p>KTC2229/KT KTA949/KTA</p> 
--	---	---	--	--	--

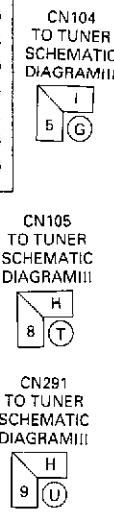
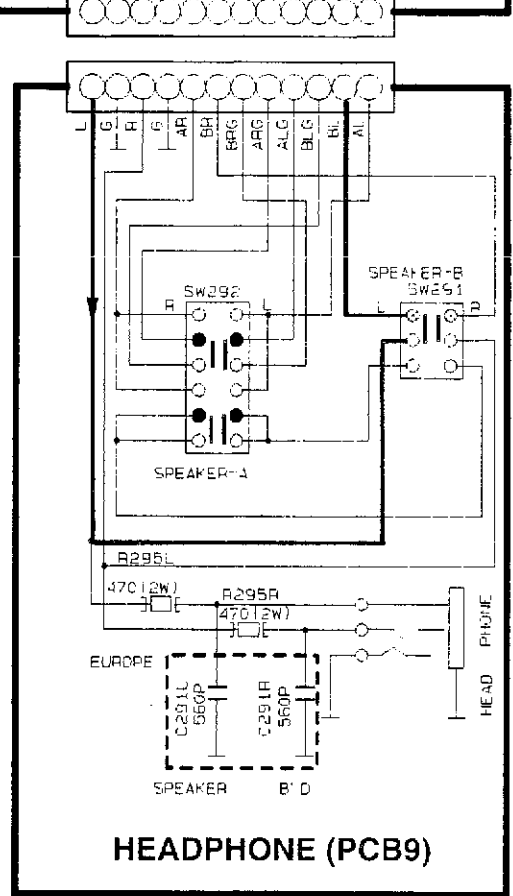
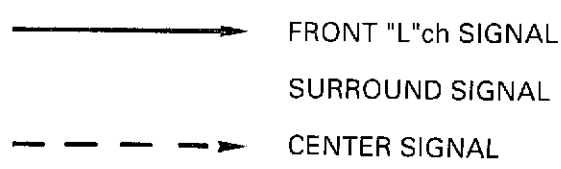
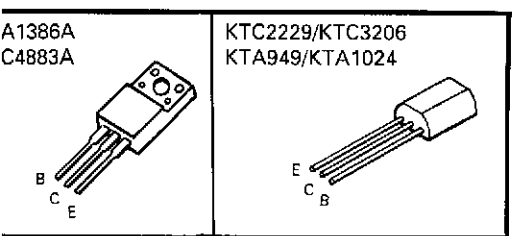
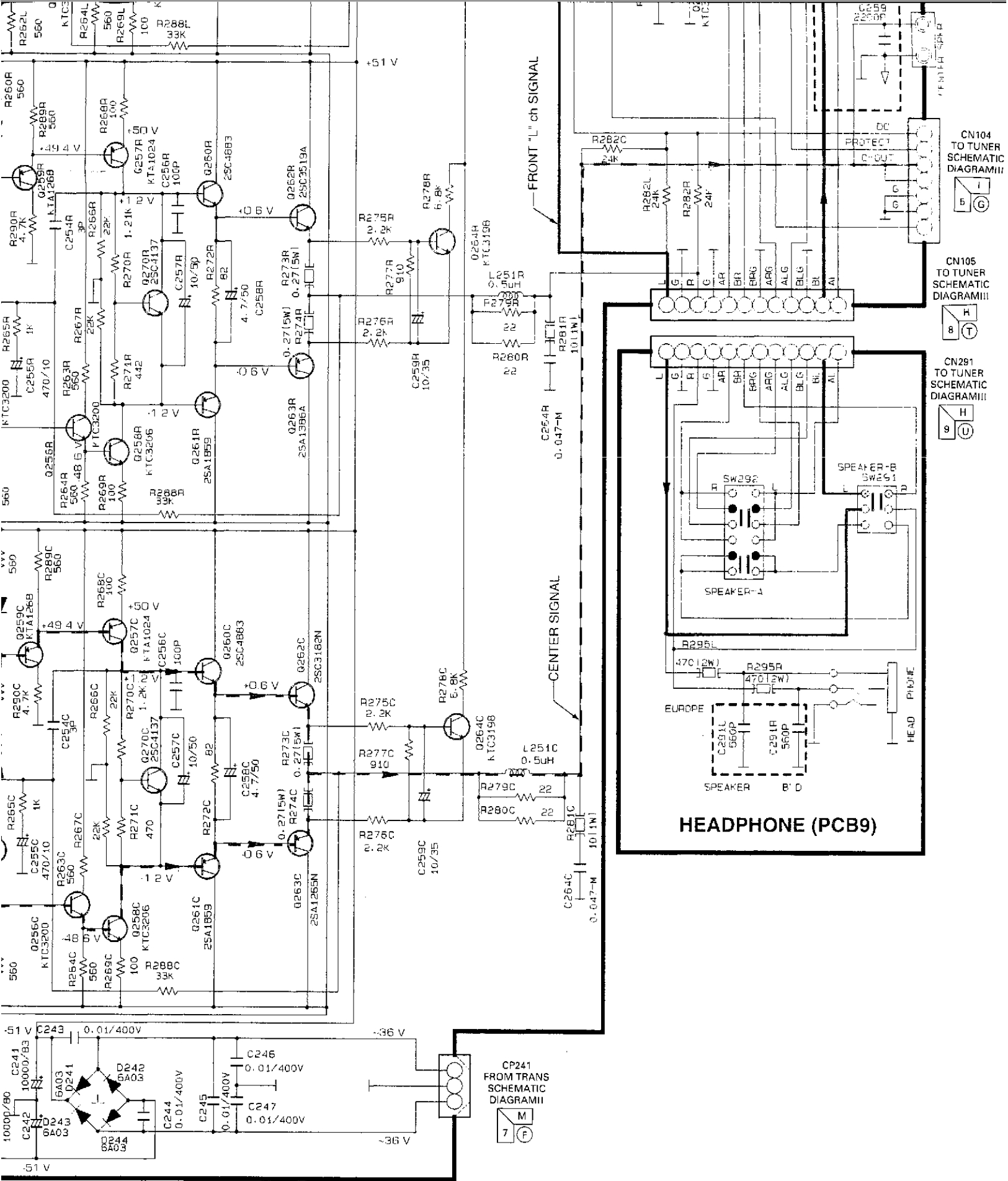

SCHEMATIC DIAGRAMS II

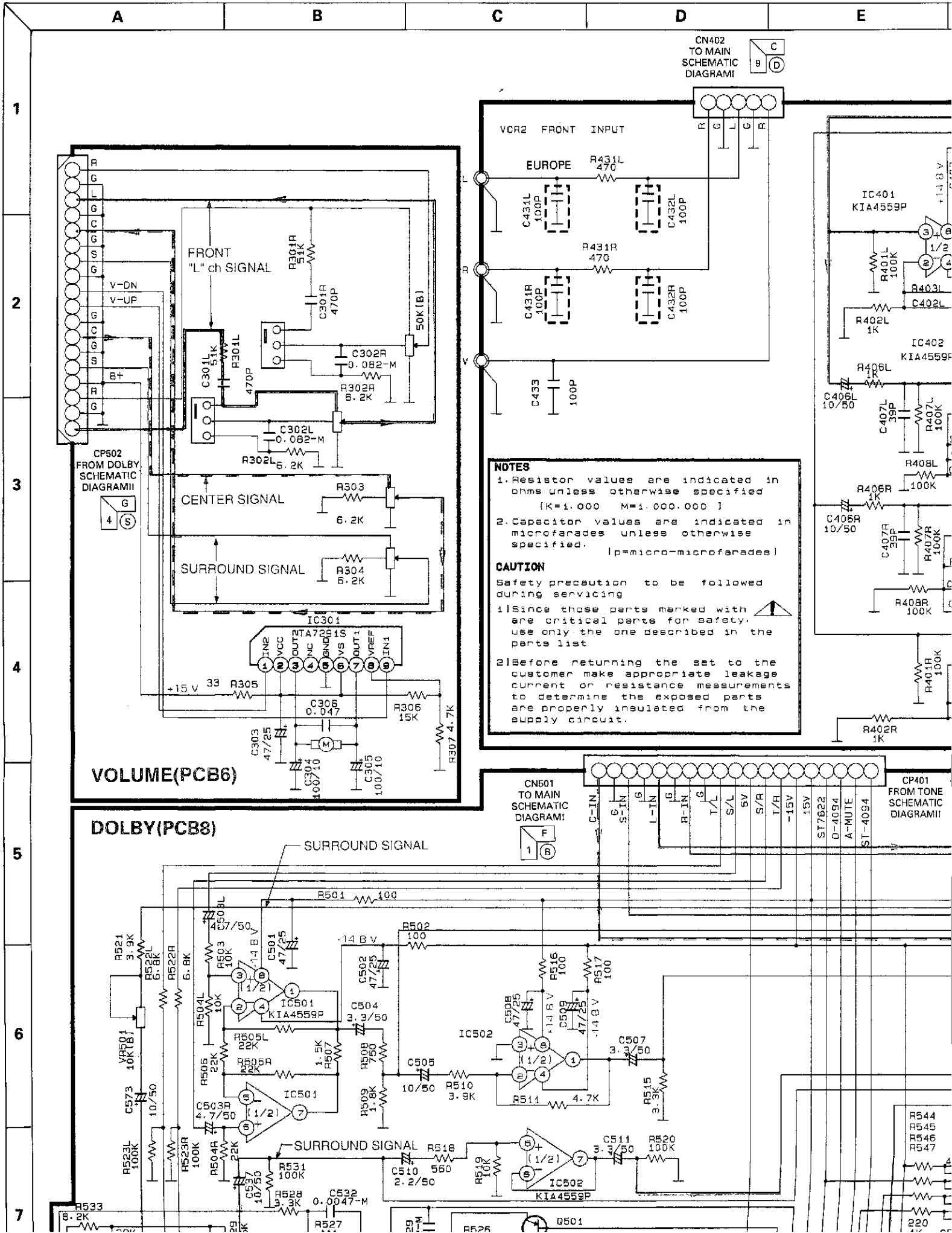

FRONT "L" ch SIGNAL
DIRECT SIGNAL

CN401
FROM DOLBY
SCHEMATIC
DIAGRAM II

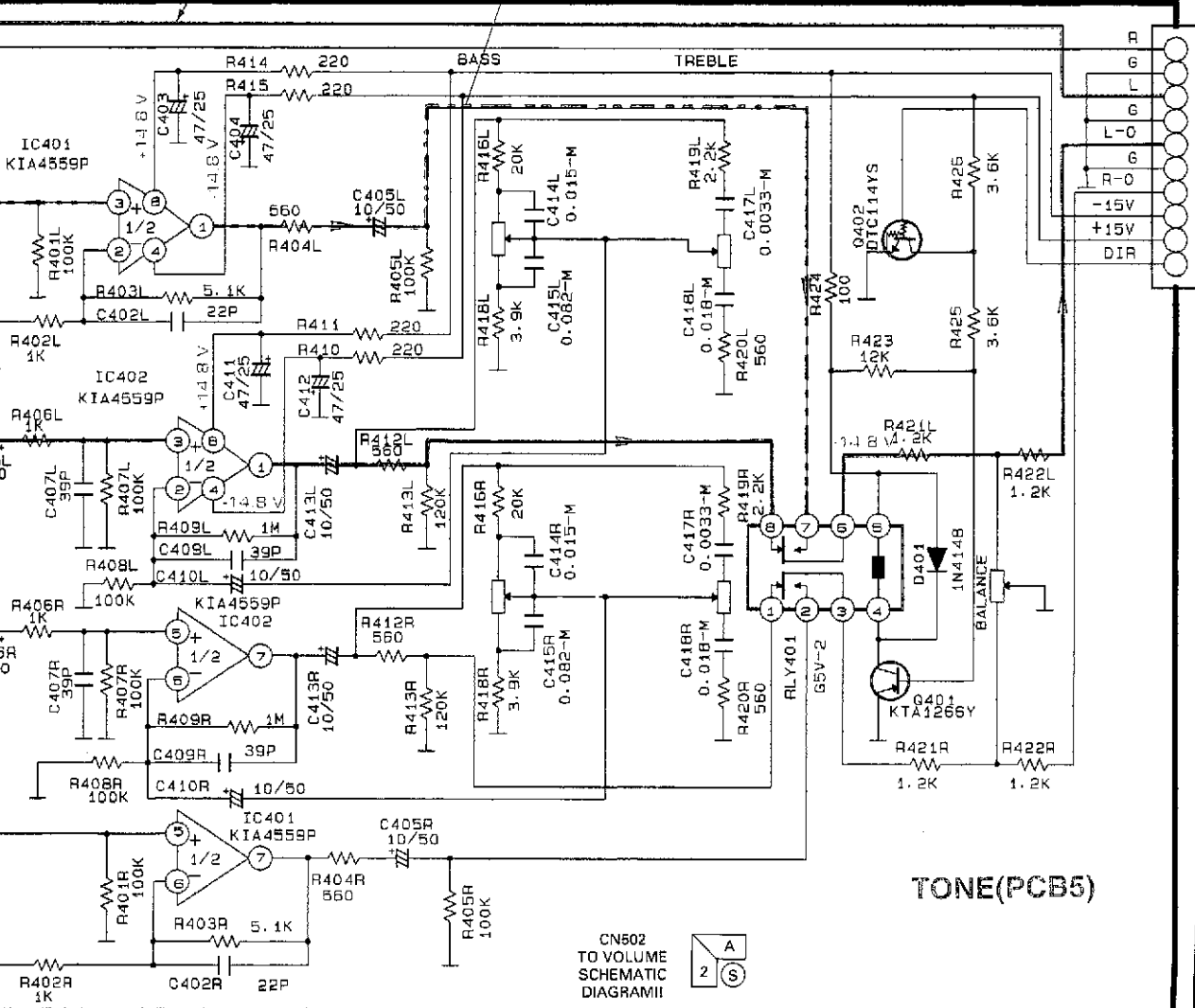

TONE(PCB5)

VERSION	INPUT
UL/CSA	AC120V/60Hz
EUROPE	AC230V/50Hz

CN502
TO VOLUME
SCHEMATIC
DIAGRAM II

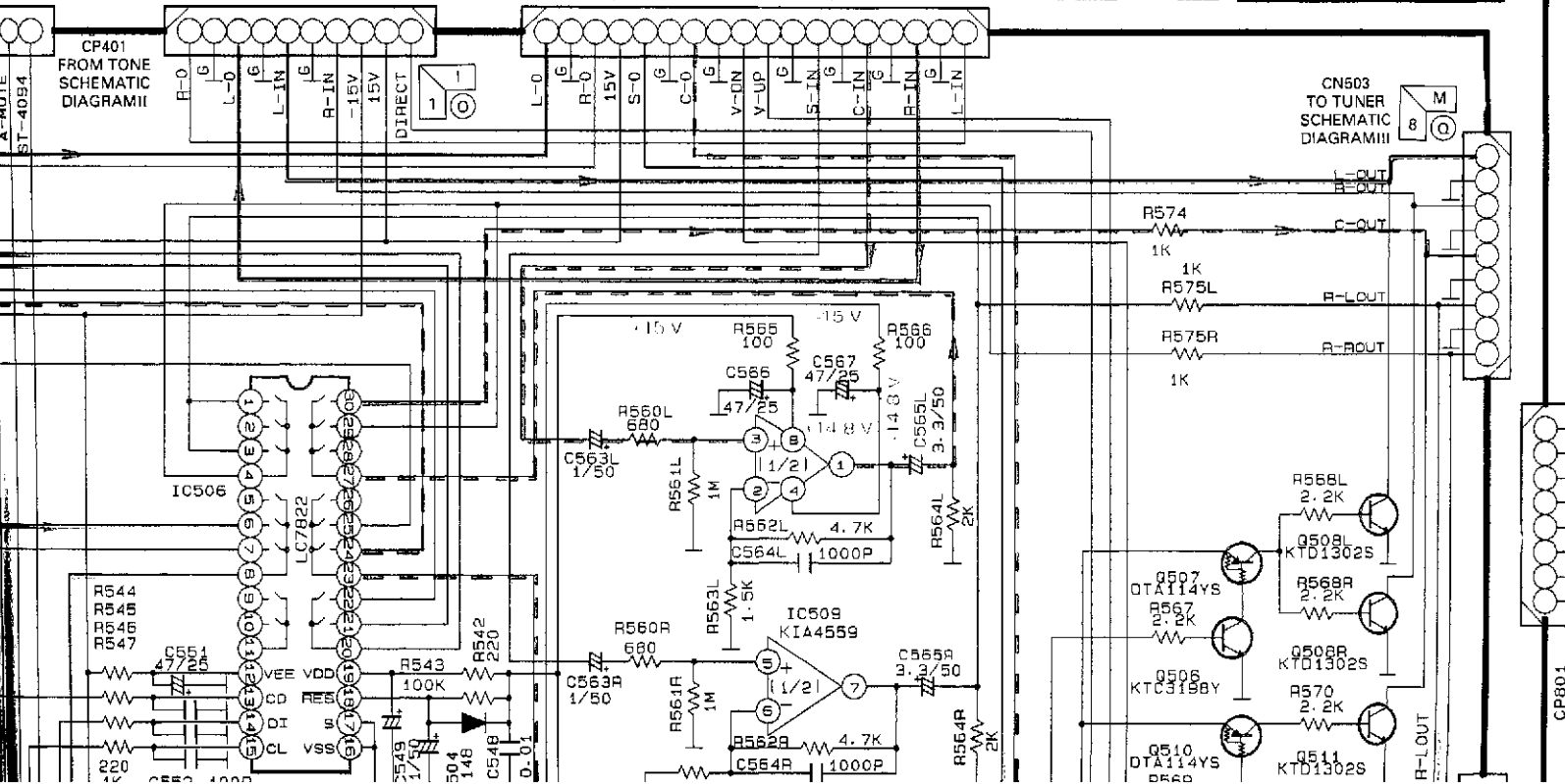
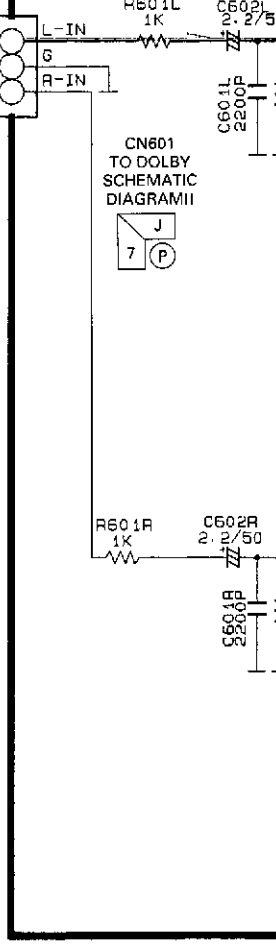

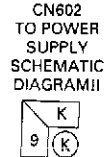
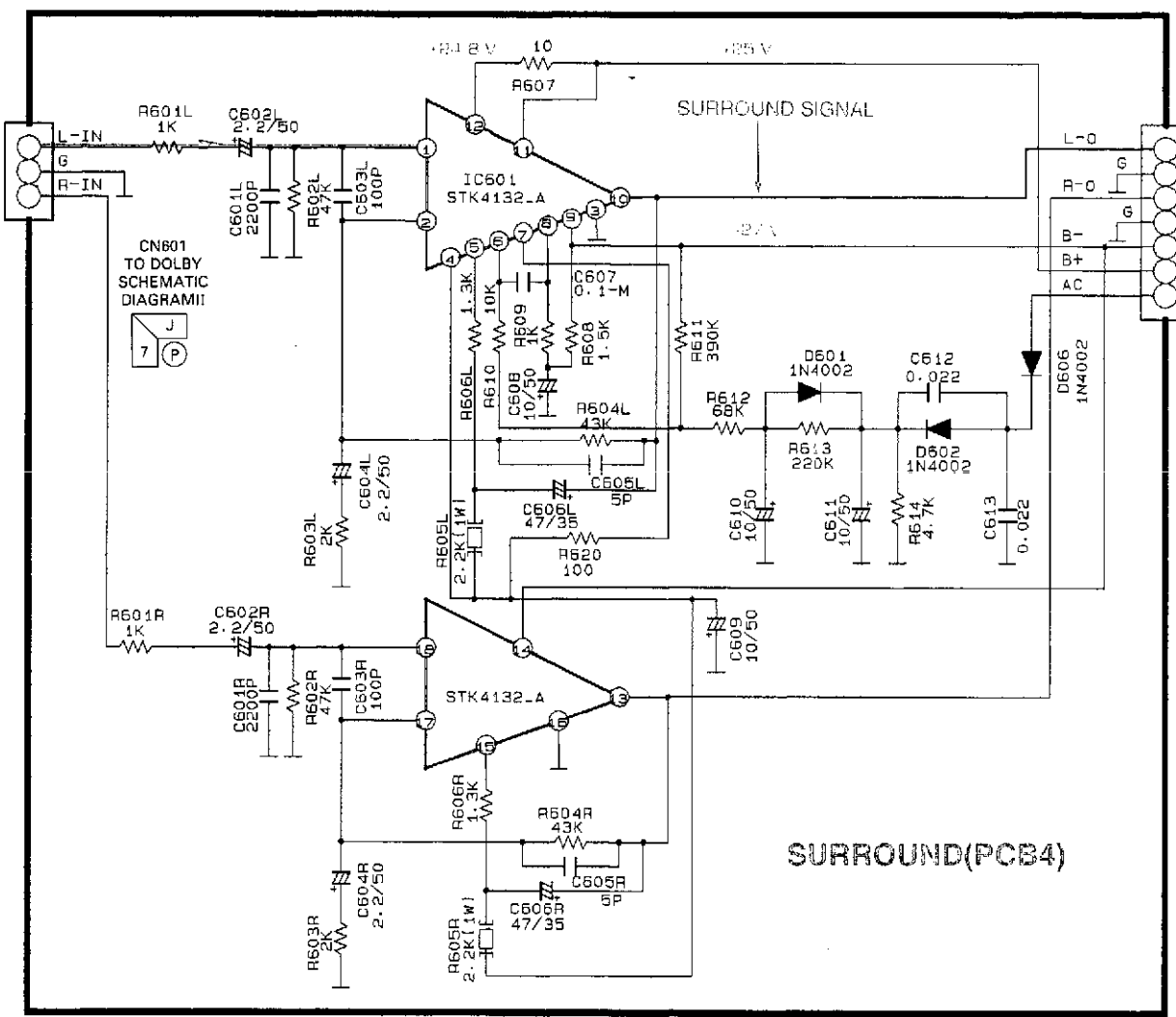
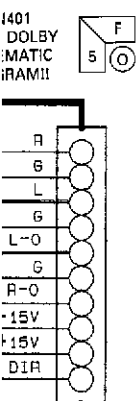

VERSION	INPUT
UL/CSA	AC120V/60Hz
EUROPE	AC230V/50Hz

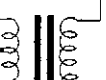
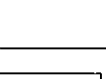
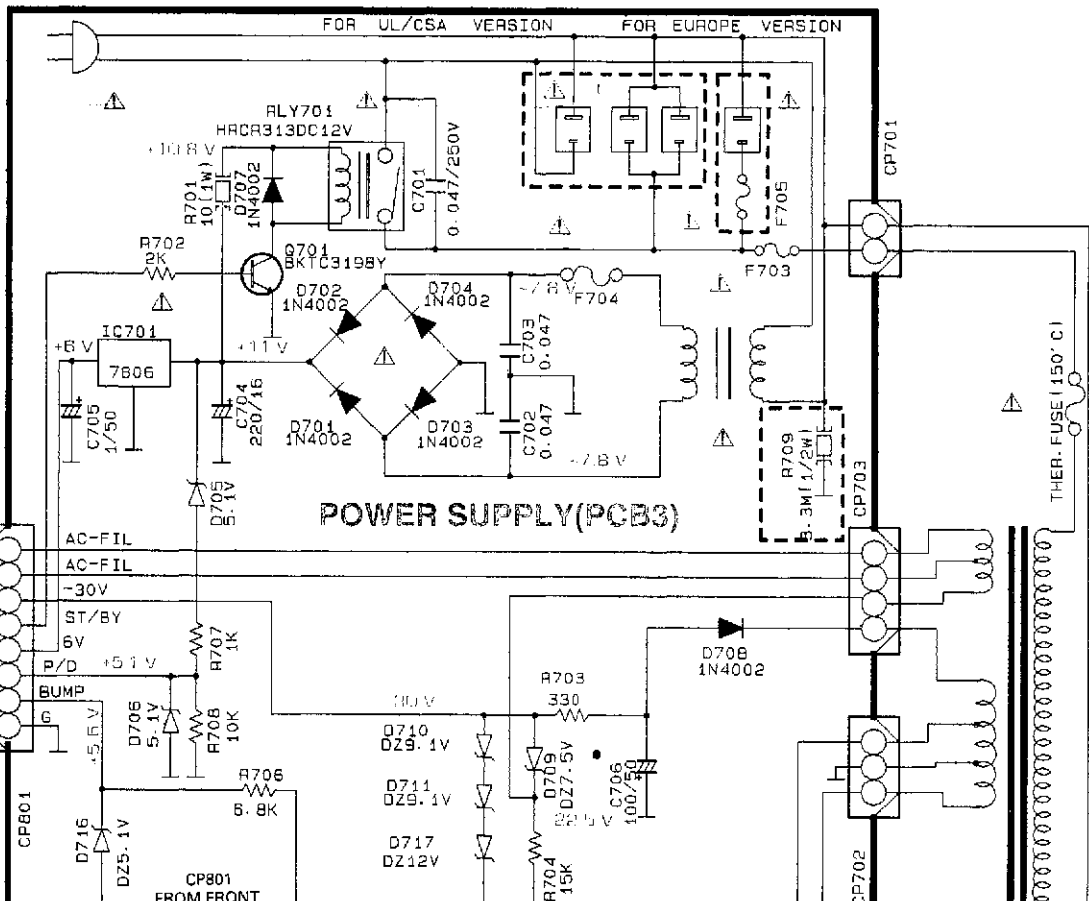
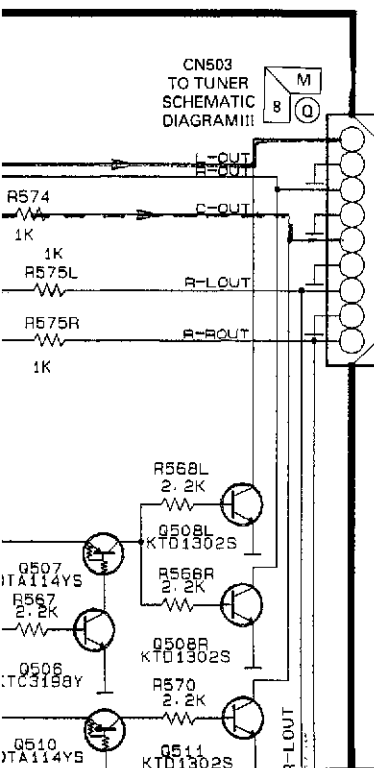

4
5
6
7
8
9

VOLUME(PCB6)

DOLBY(PCB8)

1) Since those parts marked with are critical parts for safety, use only the one described in the parts list

2) Before returning the set to the customer make appropriate leakage current or resistance measurements to determine the exposed parts are properly insulated from the supply circuit.

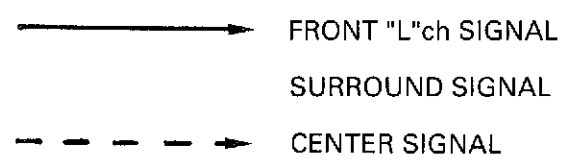
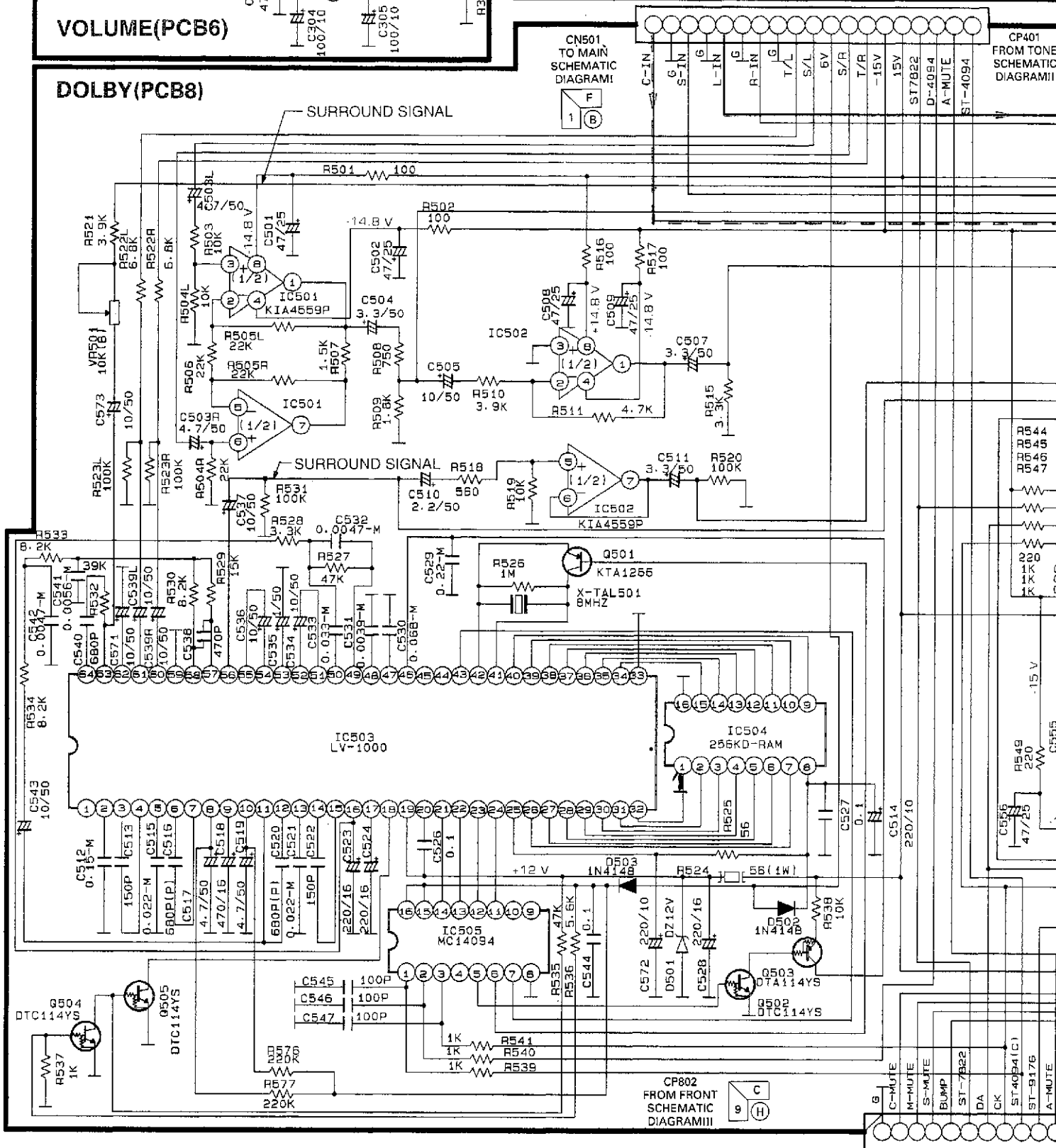

PIN CONNECTION DIAG

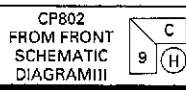
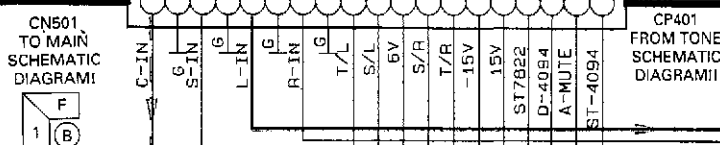
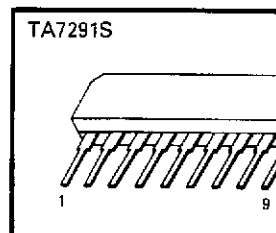

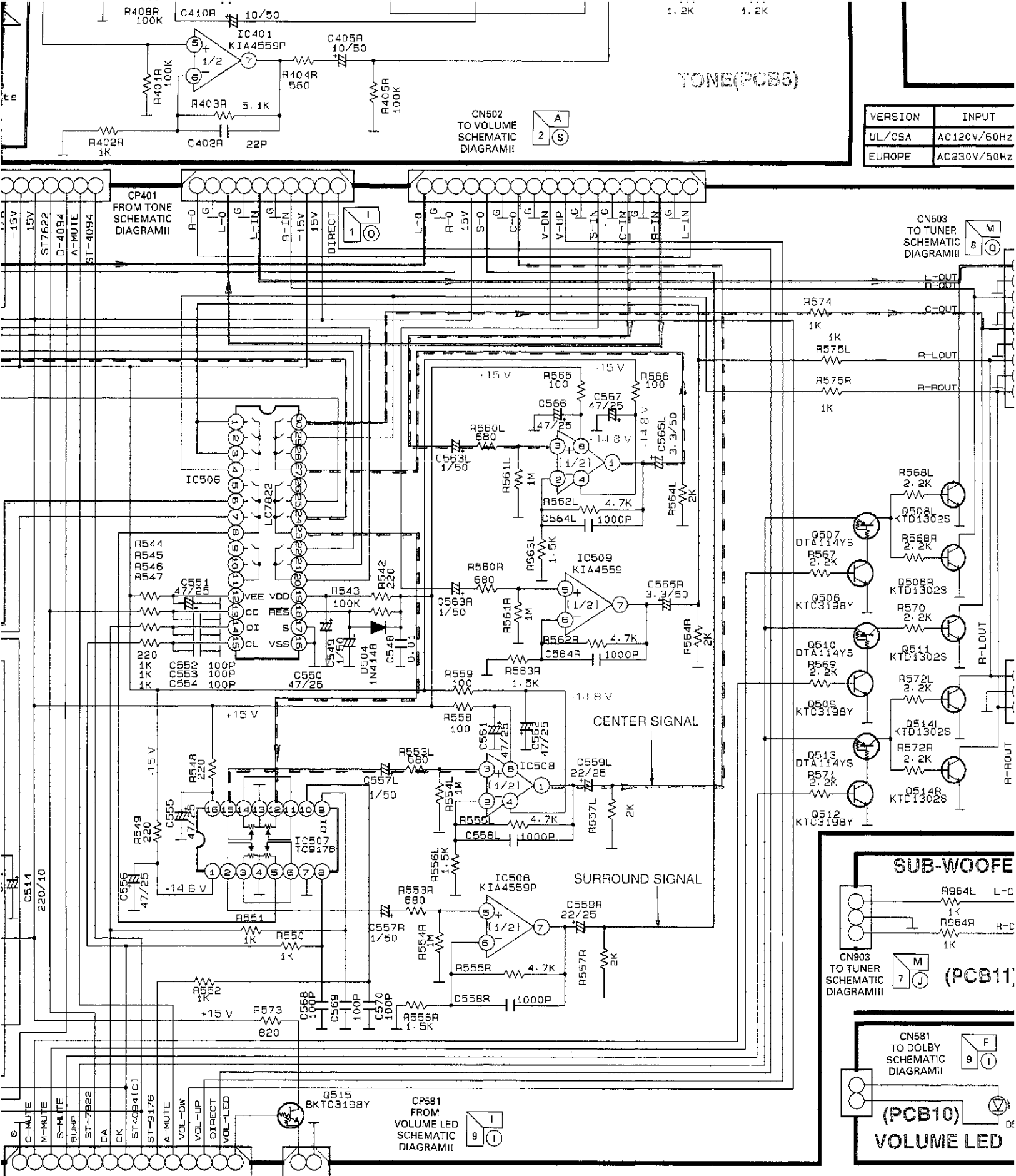

VERSION	INPUT
UL/CSA	AC120V/60Hz
EUROPE	AC230V/50Hz

PIN CONNECTION DIAGRAM OF ICs.

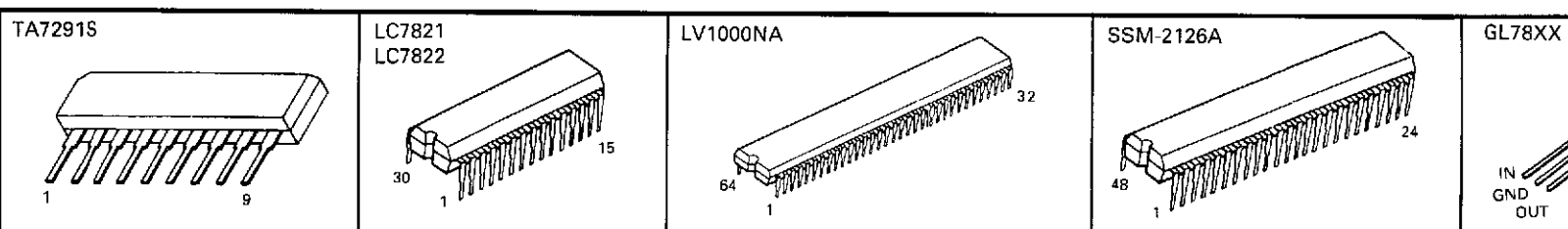

VERSION	INPUT
UL/CSA	AC120V/60Hz
EUROPE	AC230V/50Hz

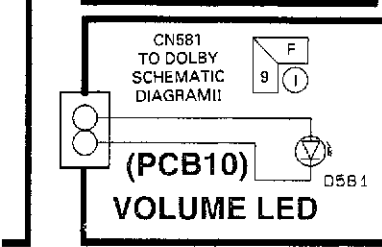
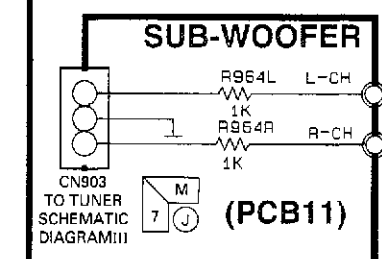
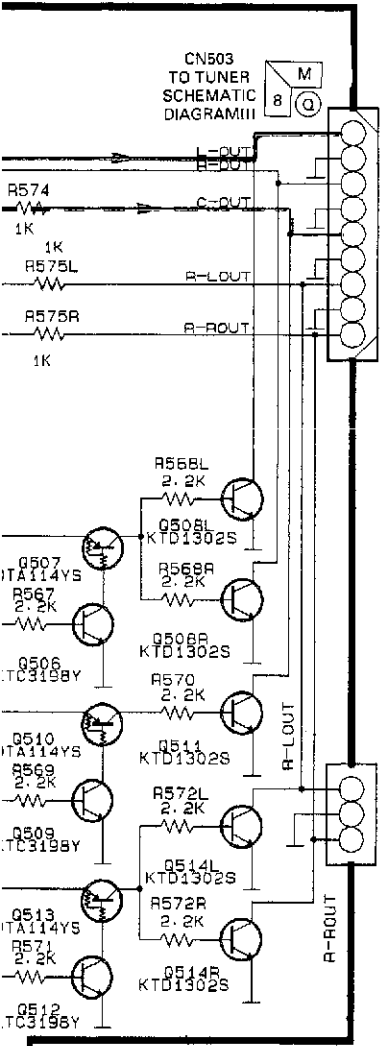
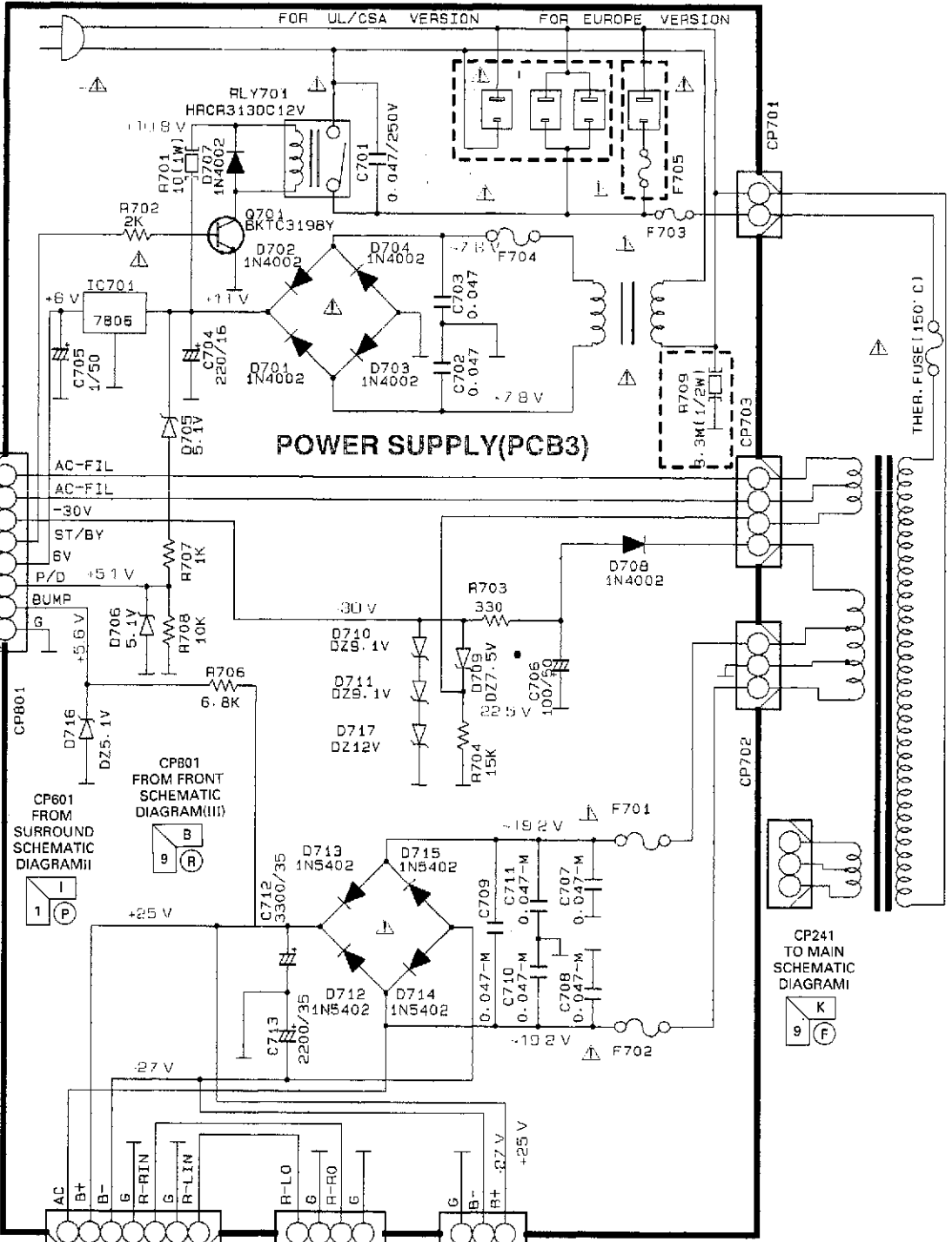

NO	VERSION	USA/CANADA	EUROPE
F701-F702		SB4A/125V	T4A/250V
F703		SB6A/125V	T4A/250V
F704		NB315mA/125V	T500mA/250V
F705		-	T2.5A/250V
R708		3.3M(1/2W)	-

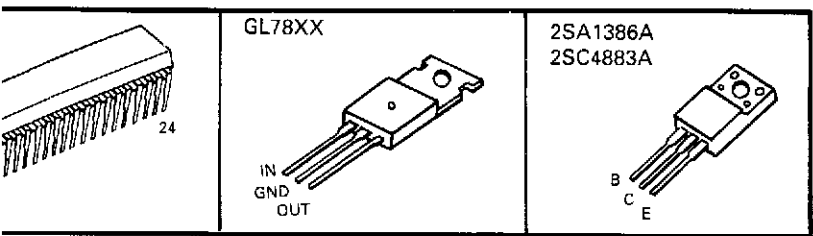

SCHEMATIC DIAGRAMS III

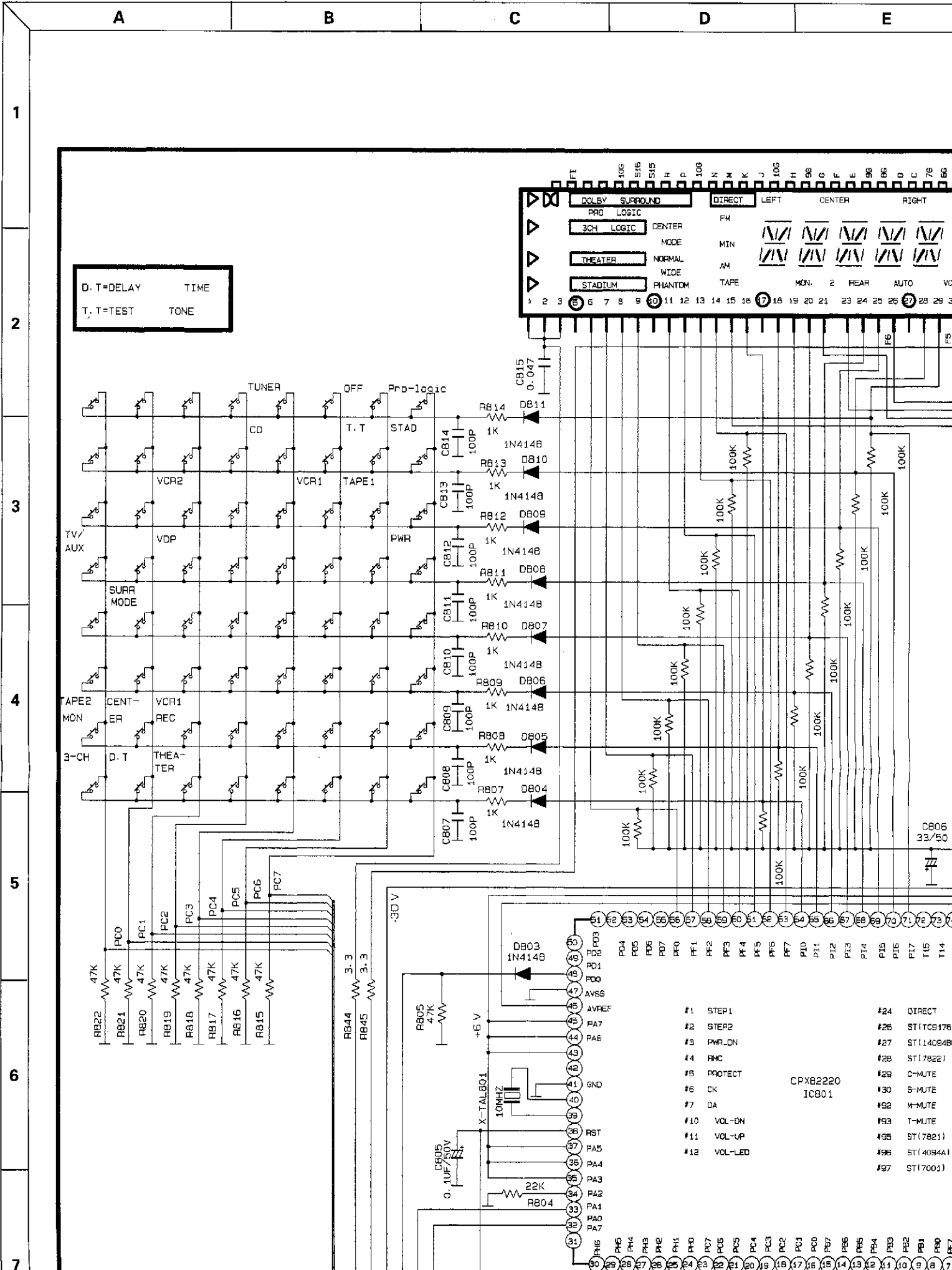

E

F

G

H

I

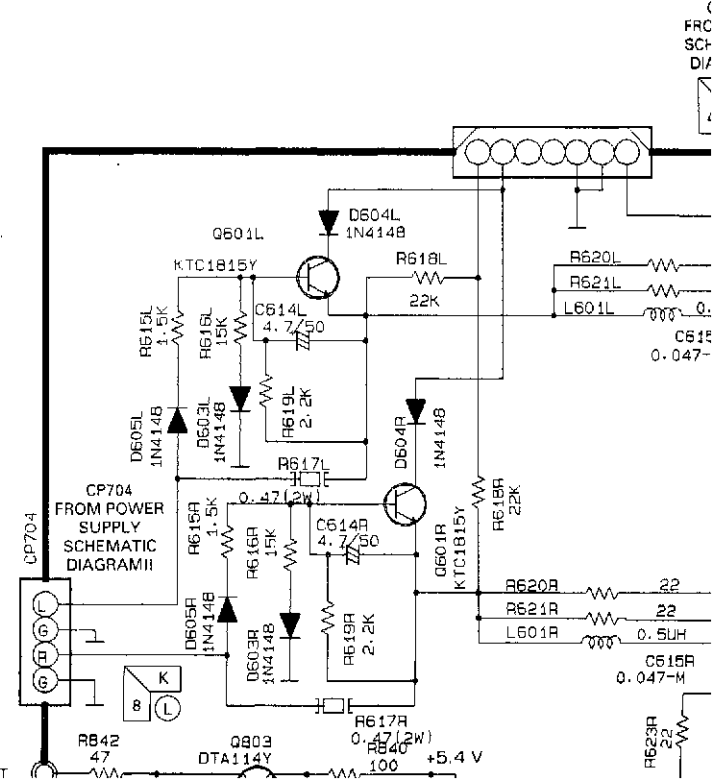
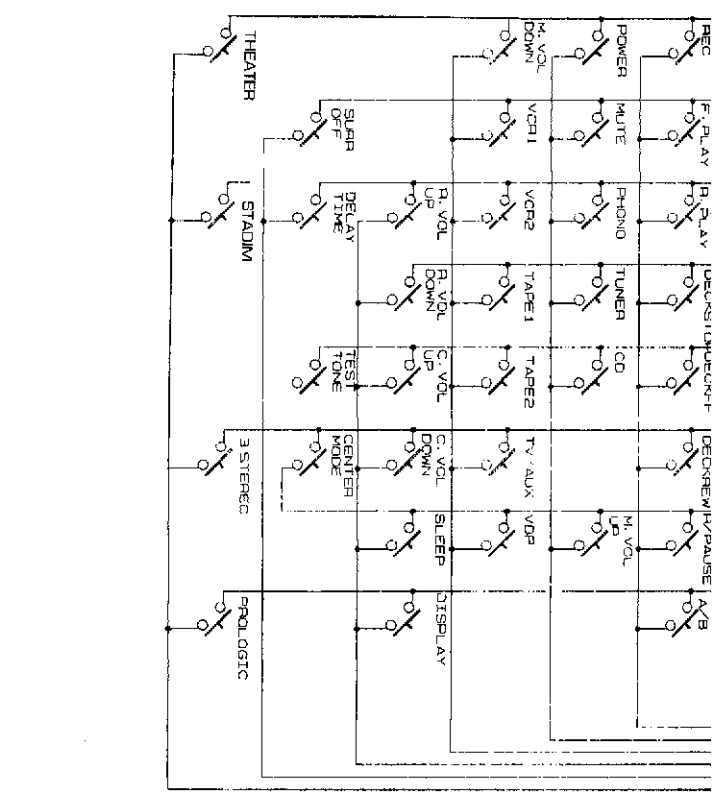
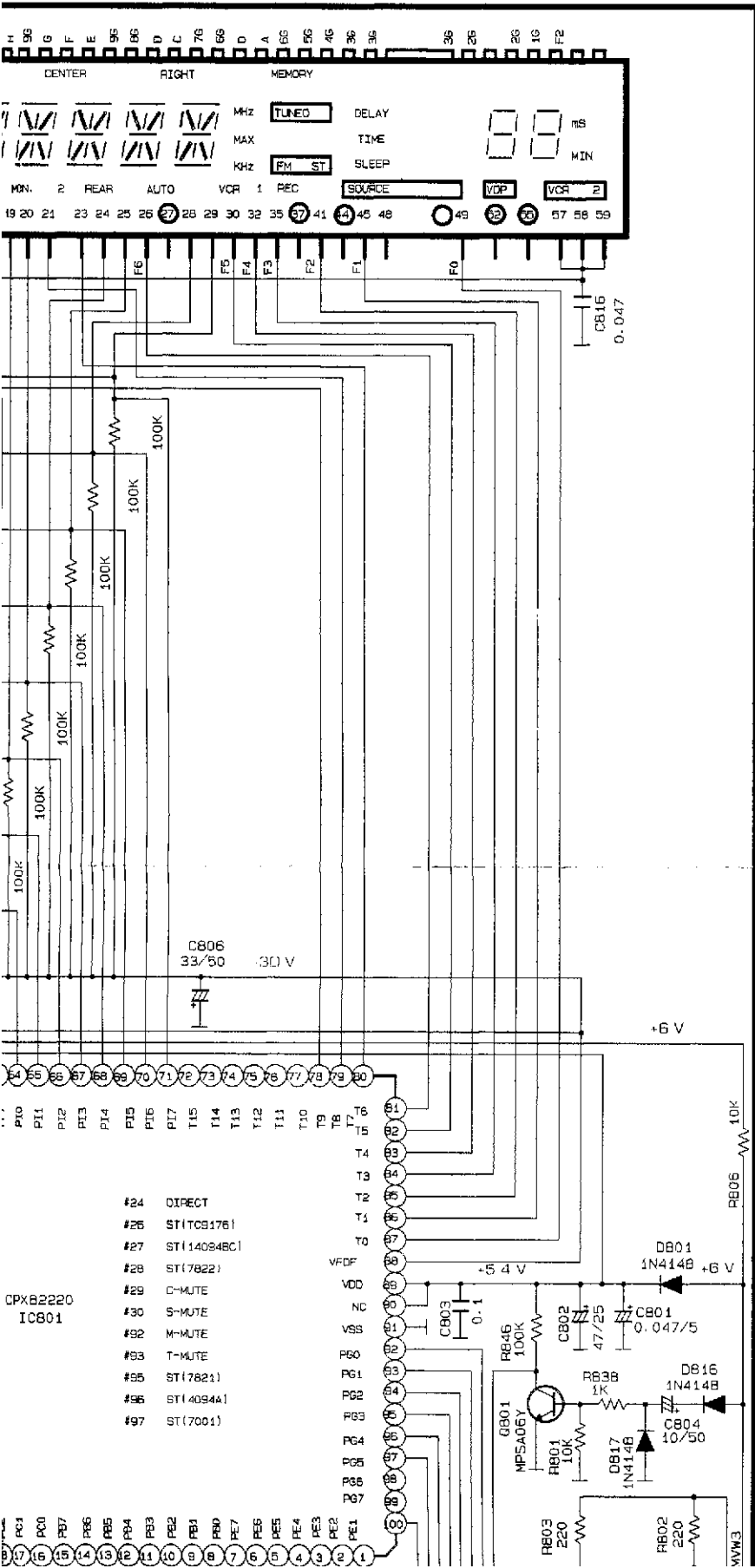

COMMANDER

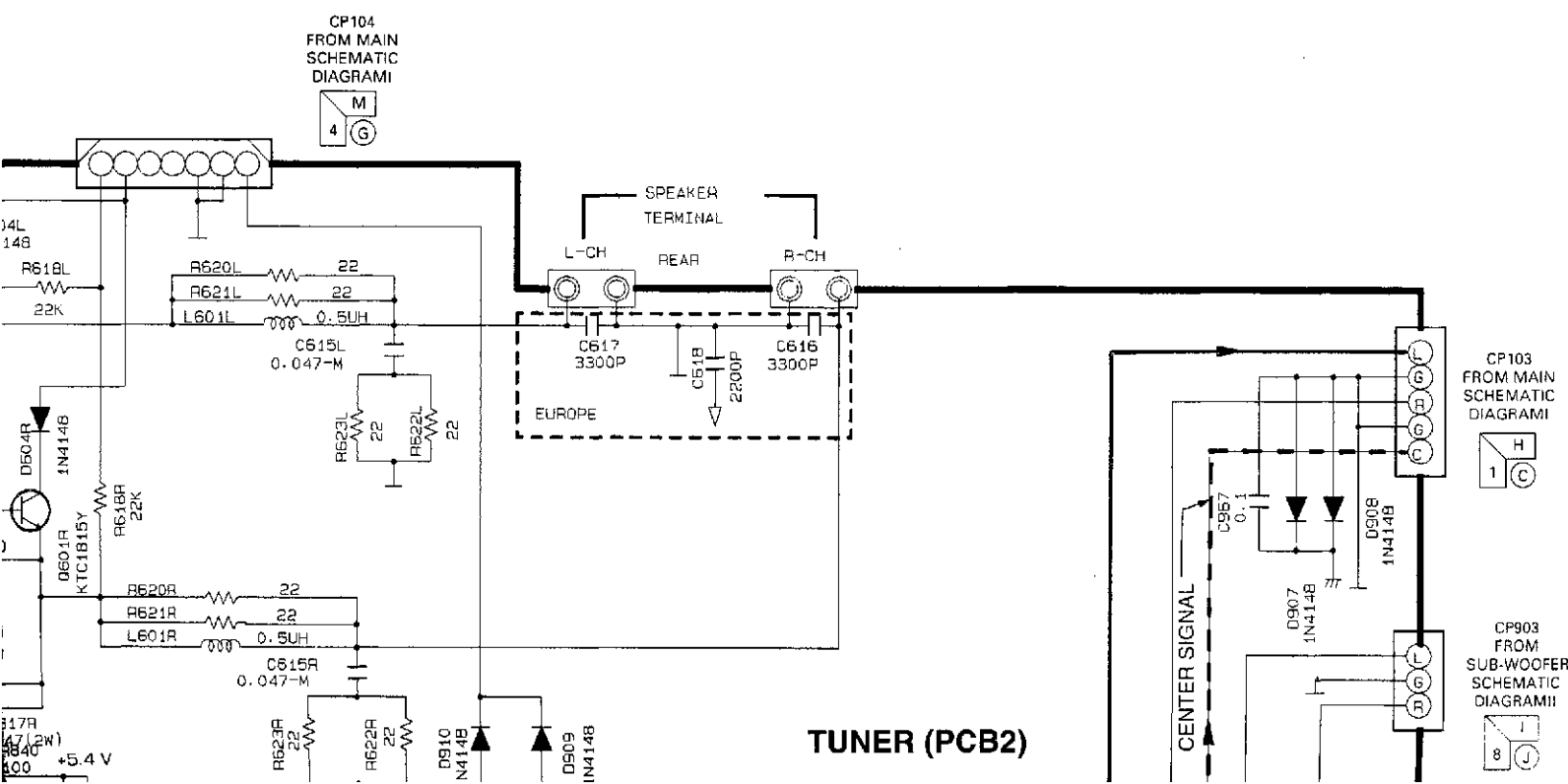
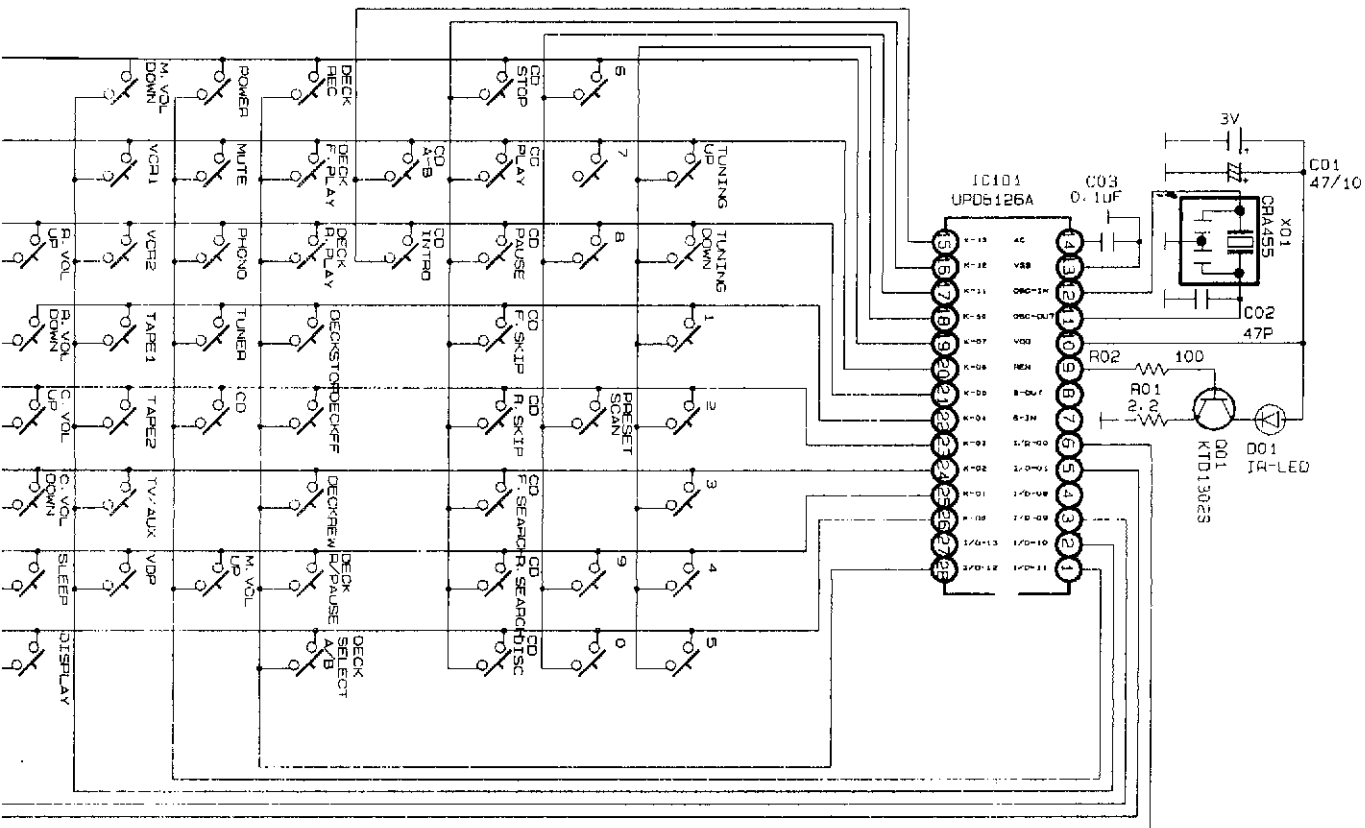

TUNER (PCB2)

4
5
6
7
8
9

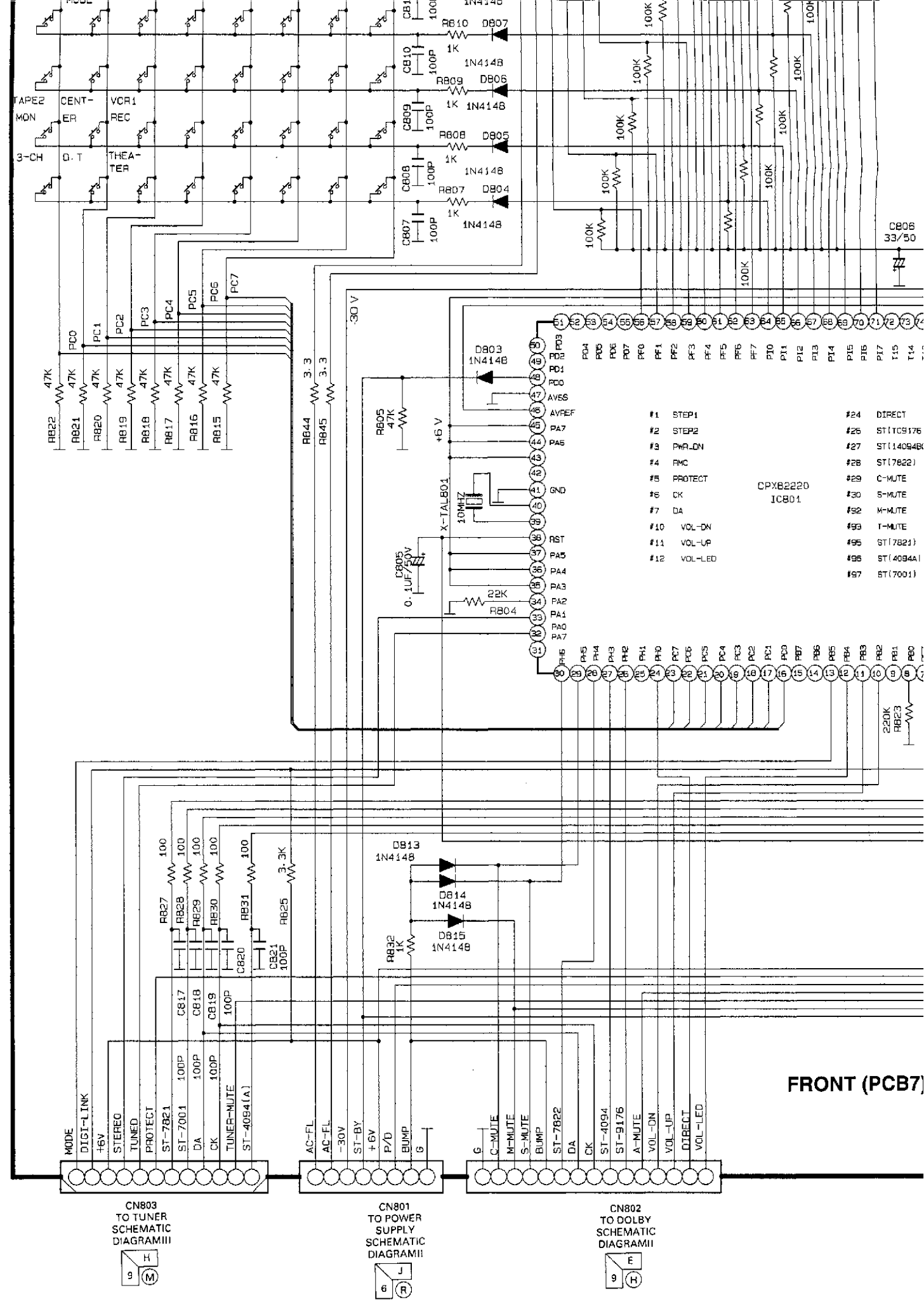

FRONT (PCB7)

CN803
TO TUNER
SCHEMATIC
DIAGRAM III

CN801
TO POWER
SUPPLY
SCHEMATIC
DIAGRAM III

CN802
TO DOLBY
SCHEMATIC
DIAGRAM III

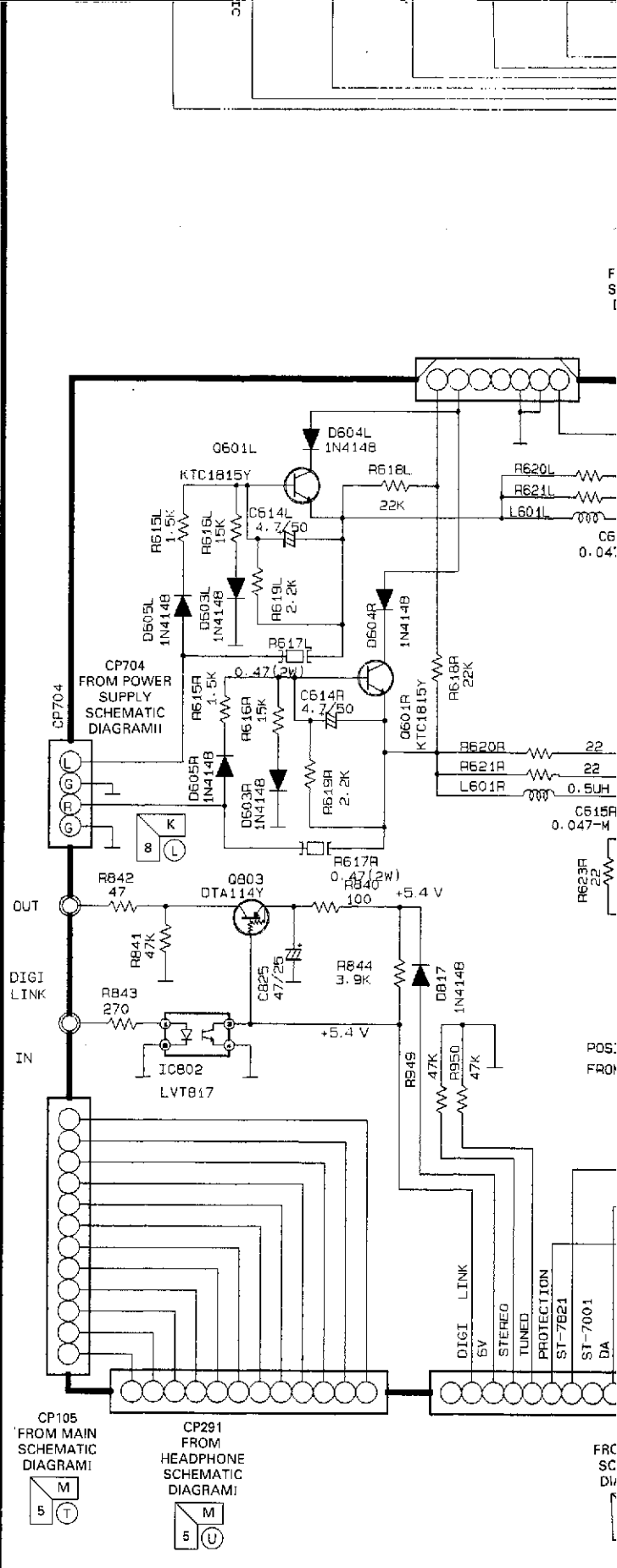
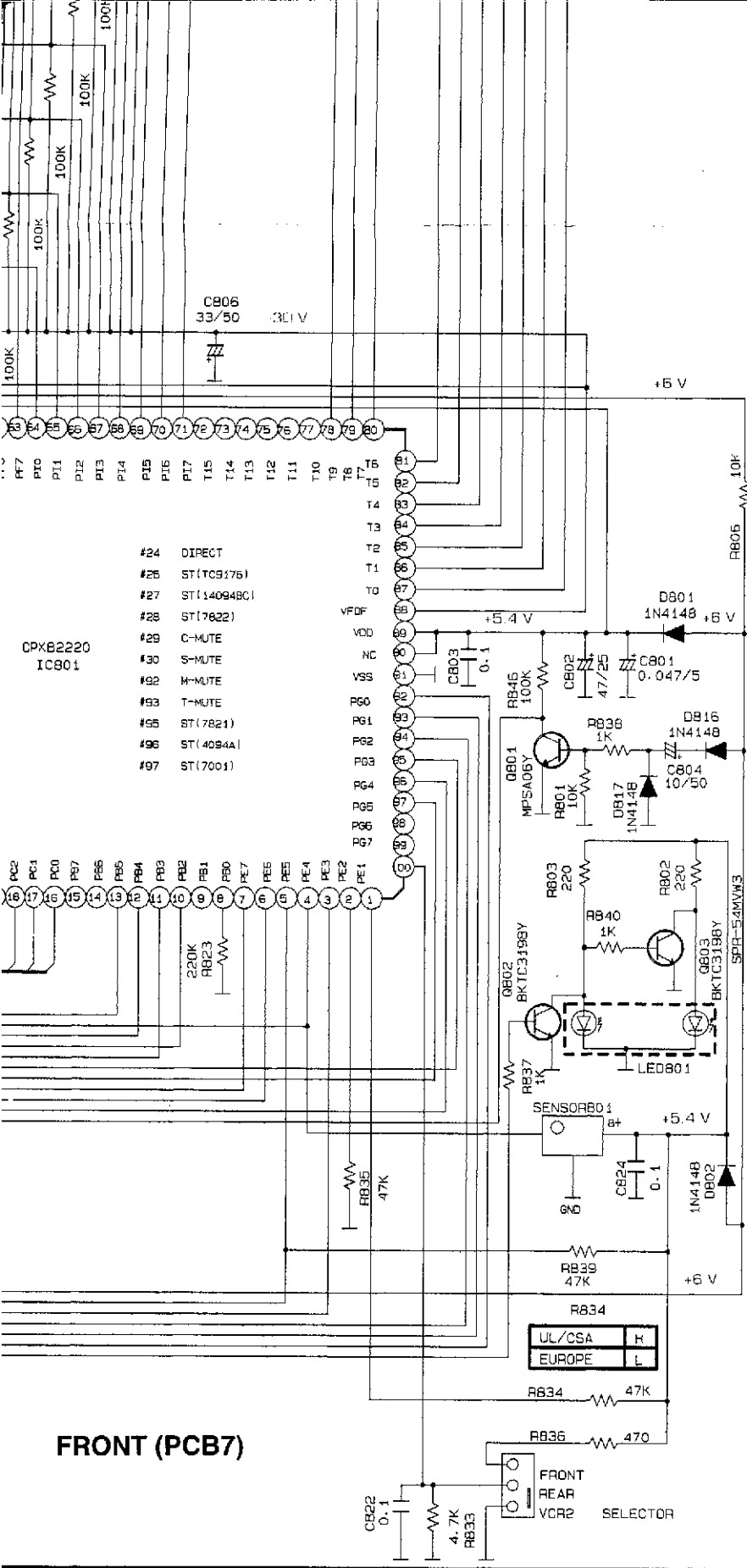

PIN CONNECTION DIAGRAM OF ICs

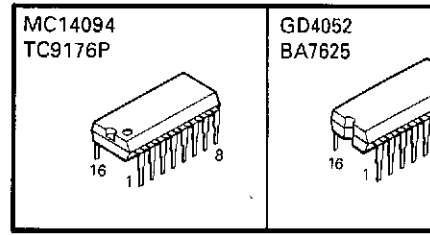

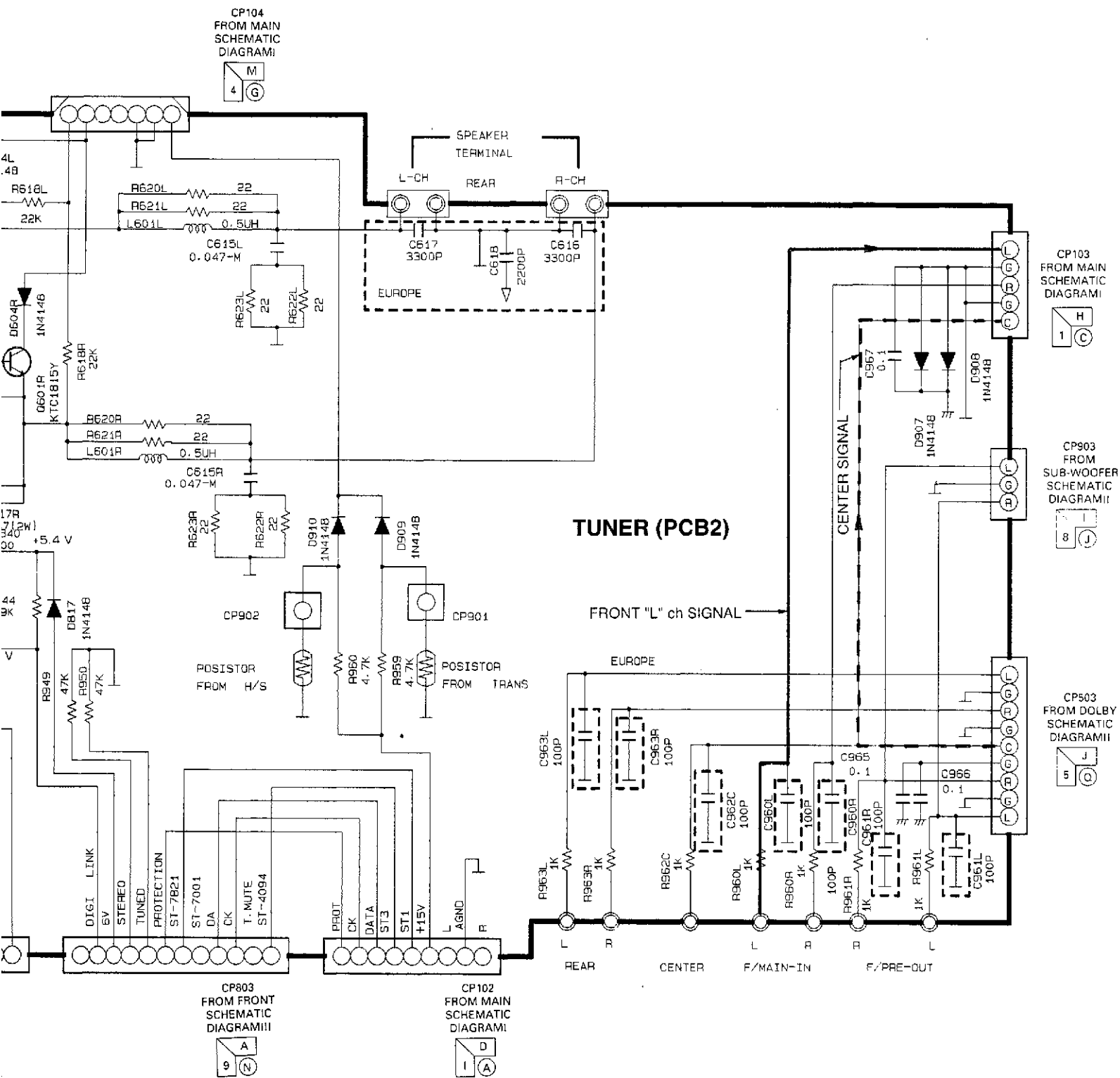

SECTION DIAGRAM OF ICs.

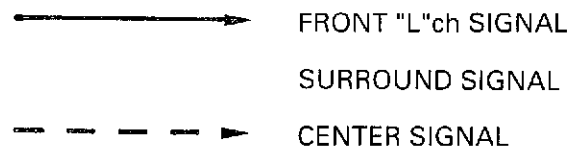
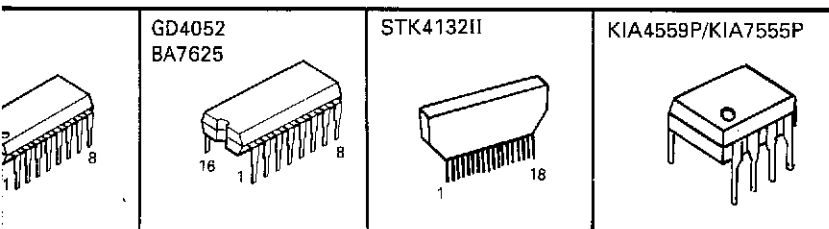

E

F

G

H

PCB10

VOLUME LED B
4001000530K

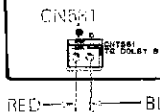

CARD CABLE. 19P

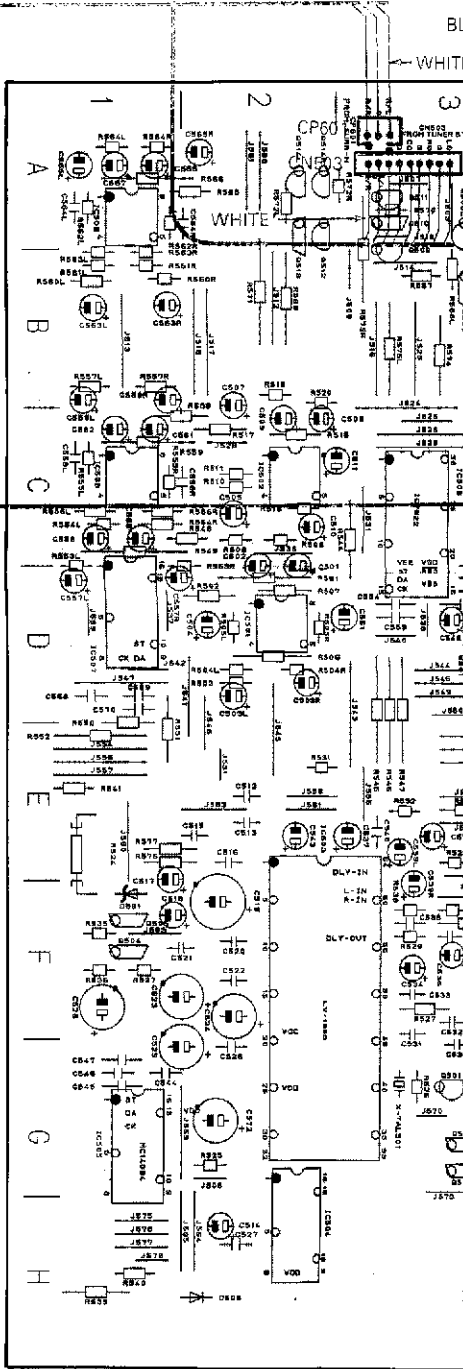
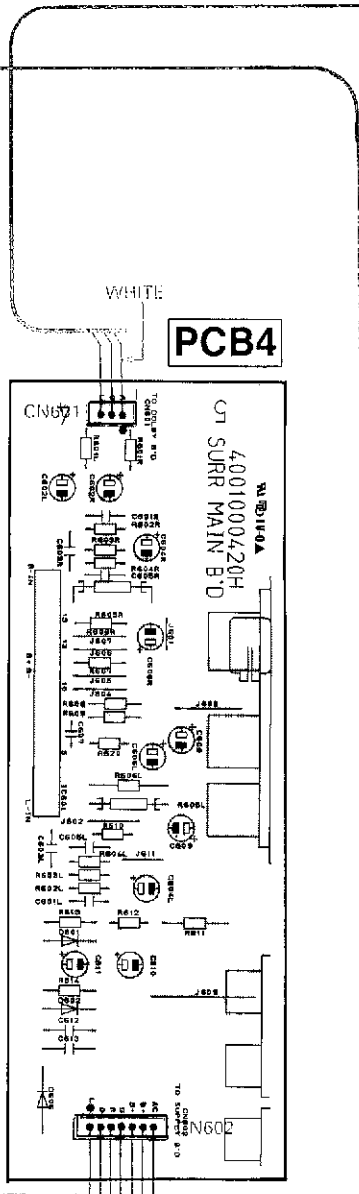
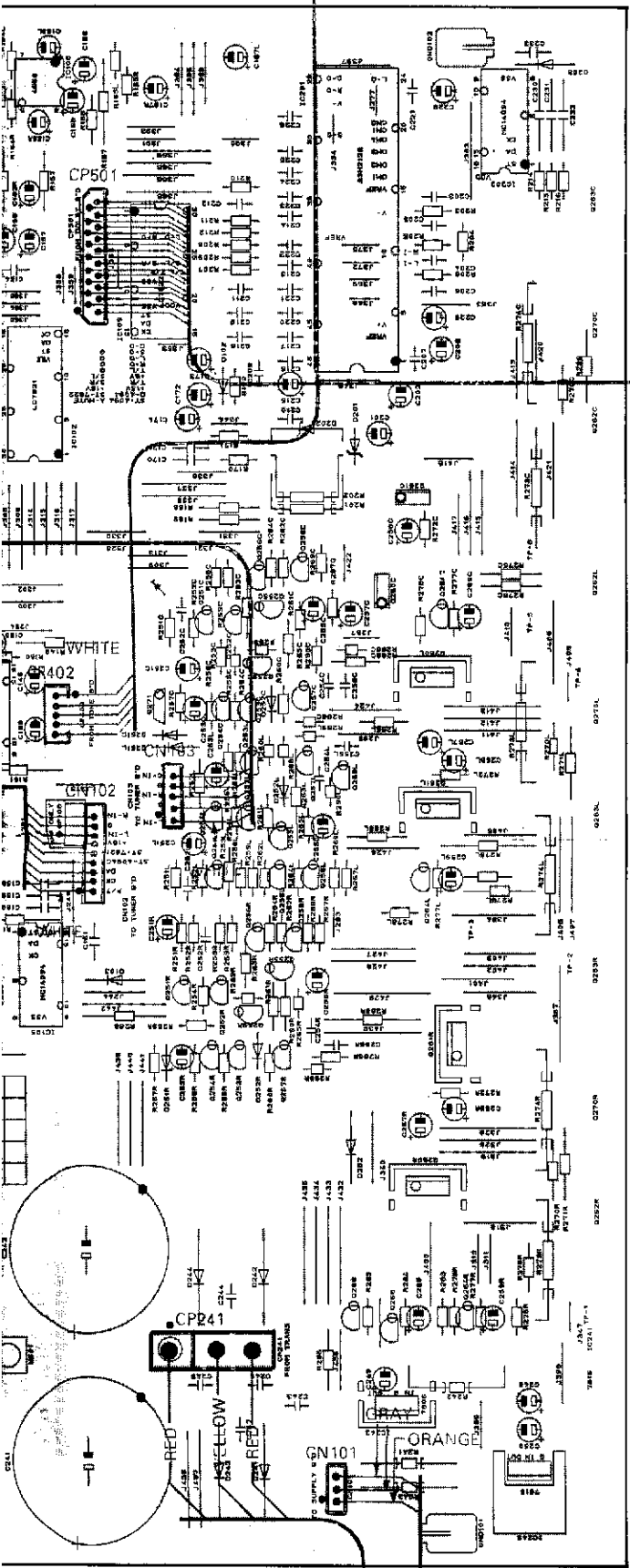

Q.S. JAMES HOFF

H

I

J

K

PCB10

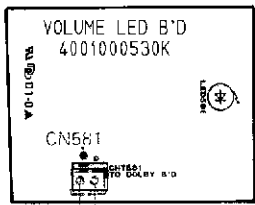

CARD CABLE, 12P

PCB5

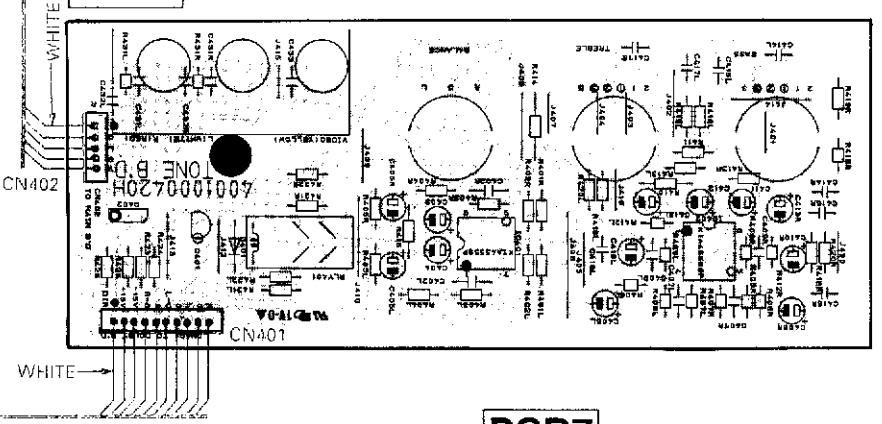

PCB7

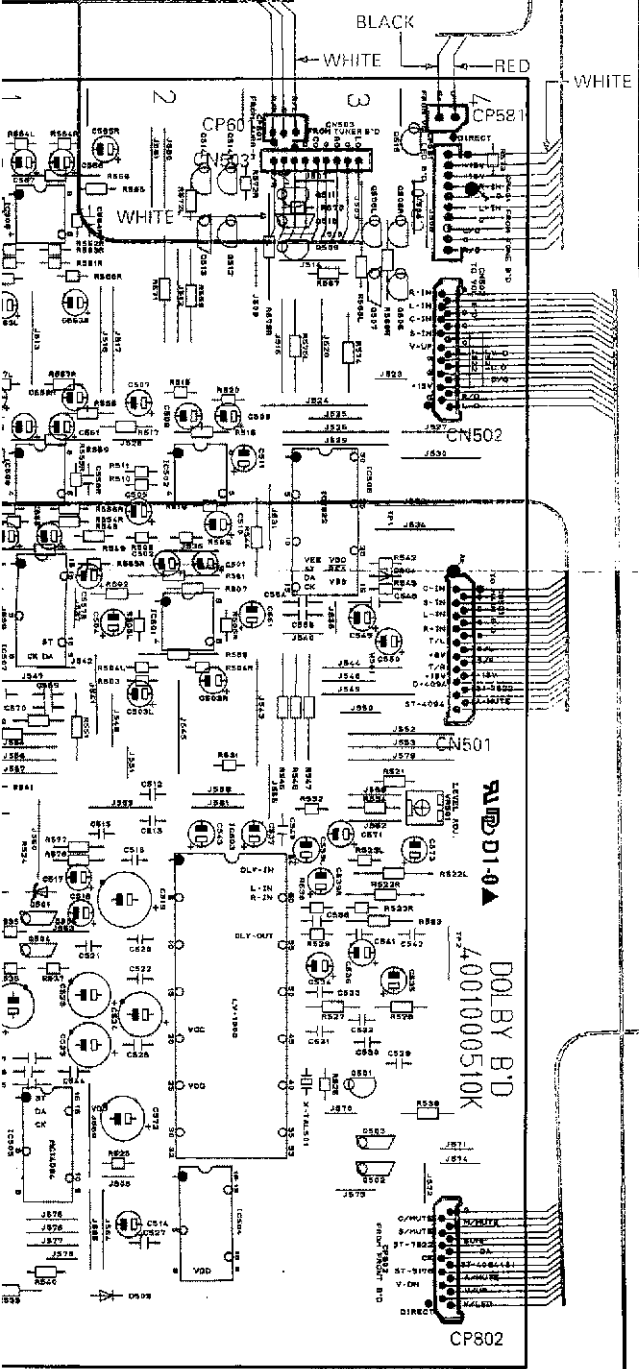
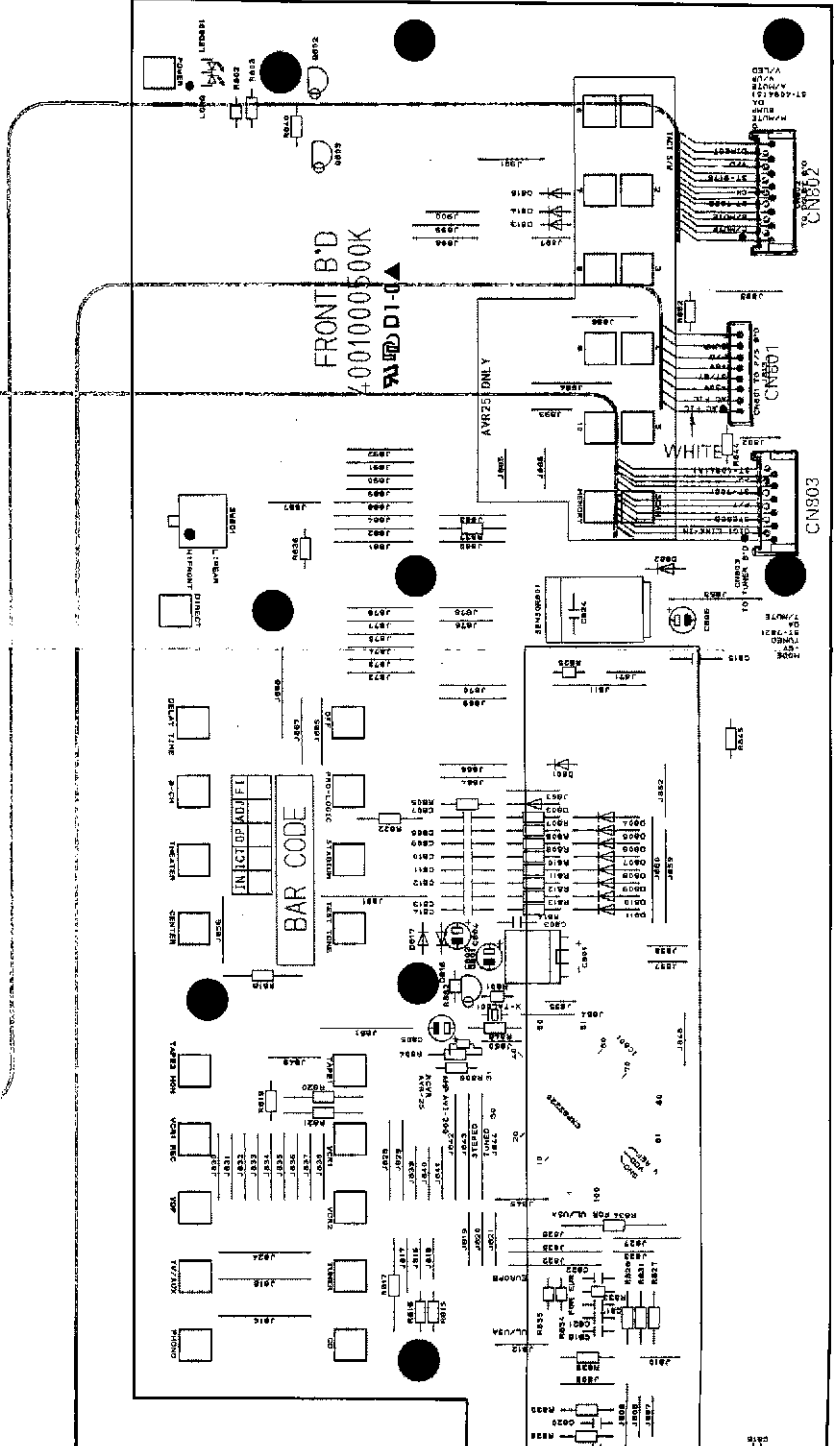

4

5

6

7

8

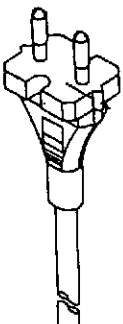
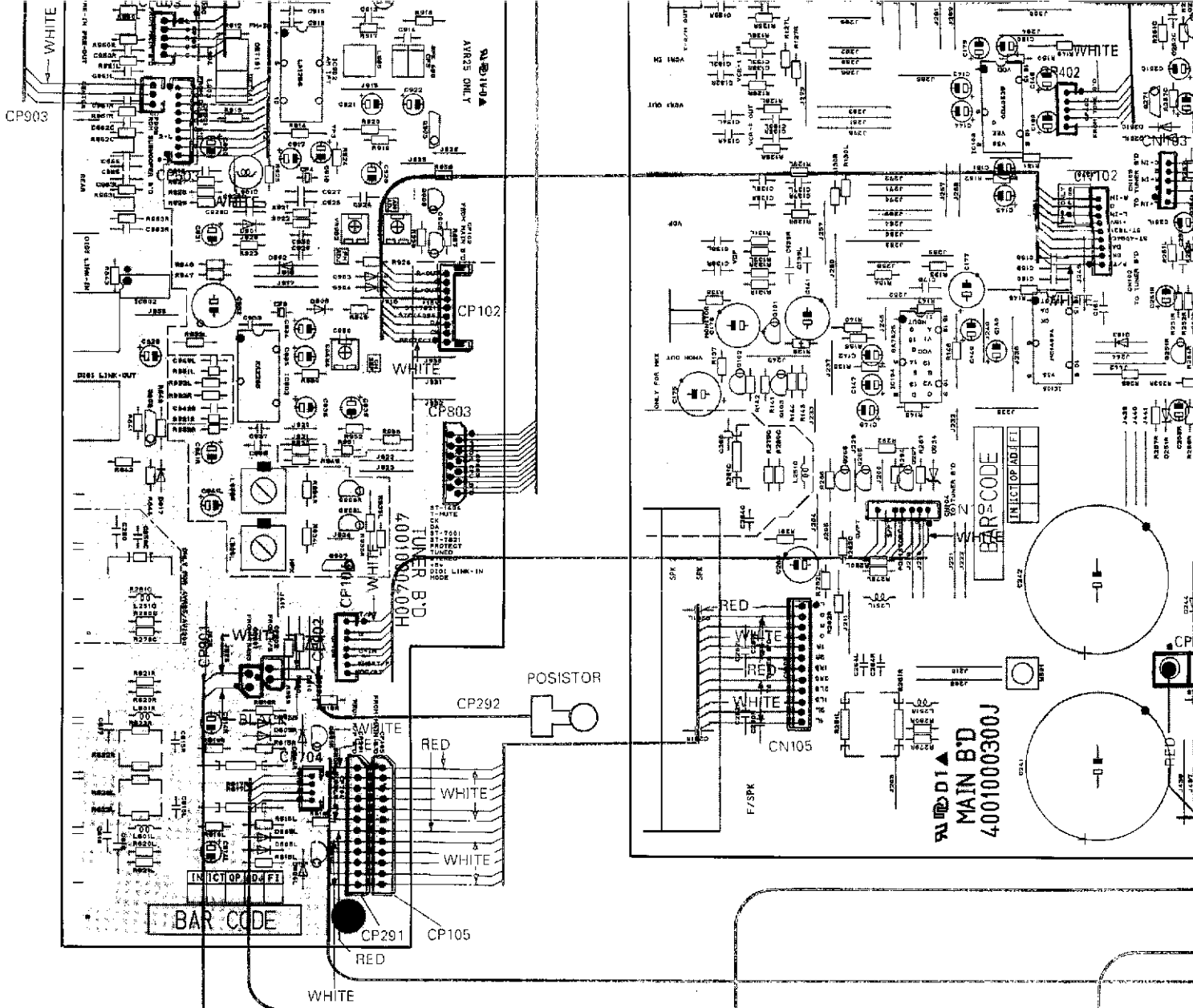

PCB3

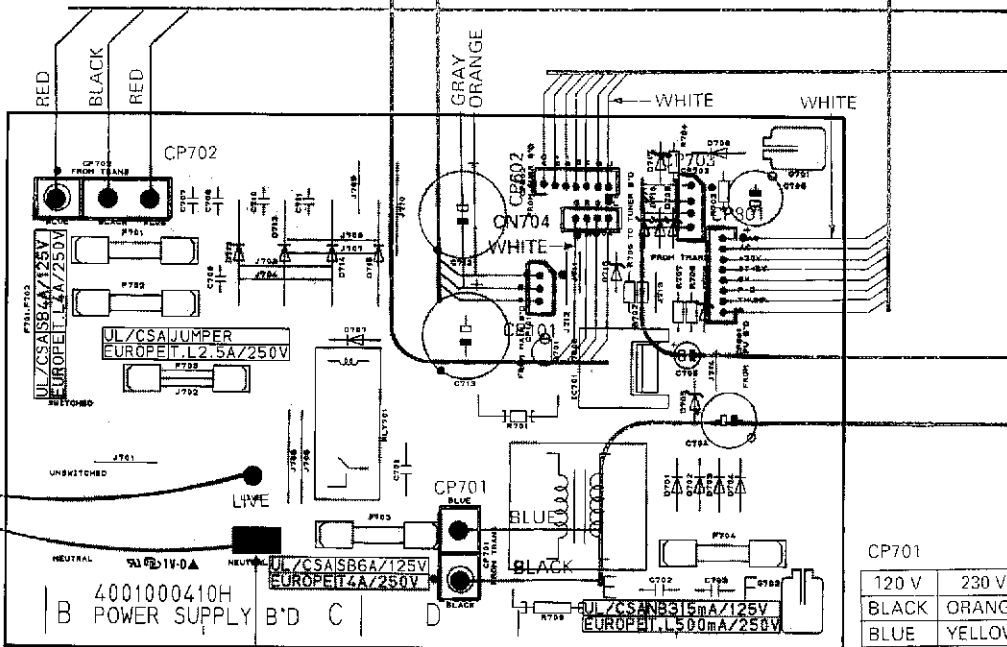

4001000410H
B POWER SUPPLY B'D C

CP701	120 V	230 V
	BLACK	ORANG
	BLUE	YELLOW

NEUTRAL

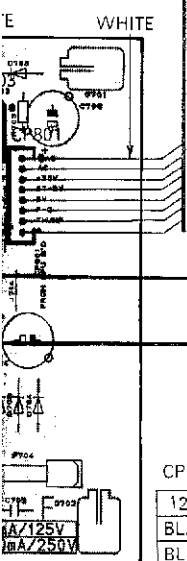
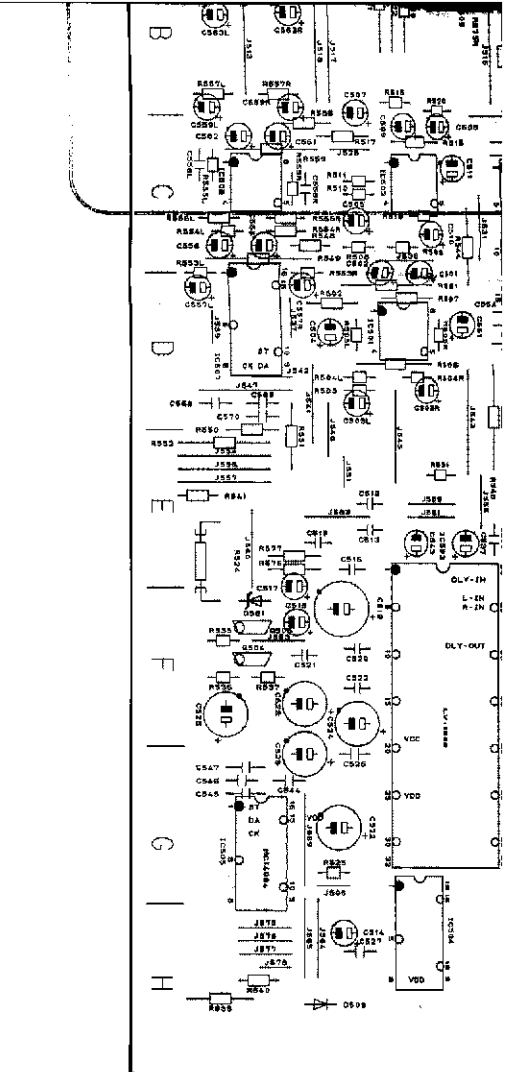
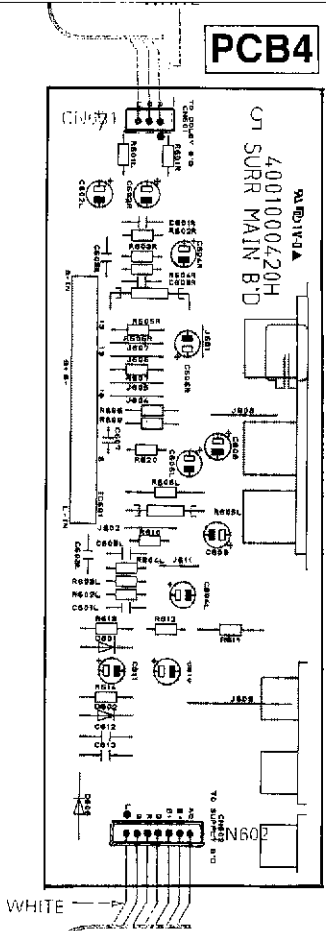
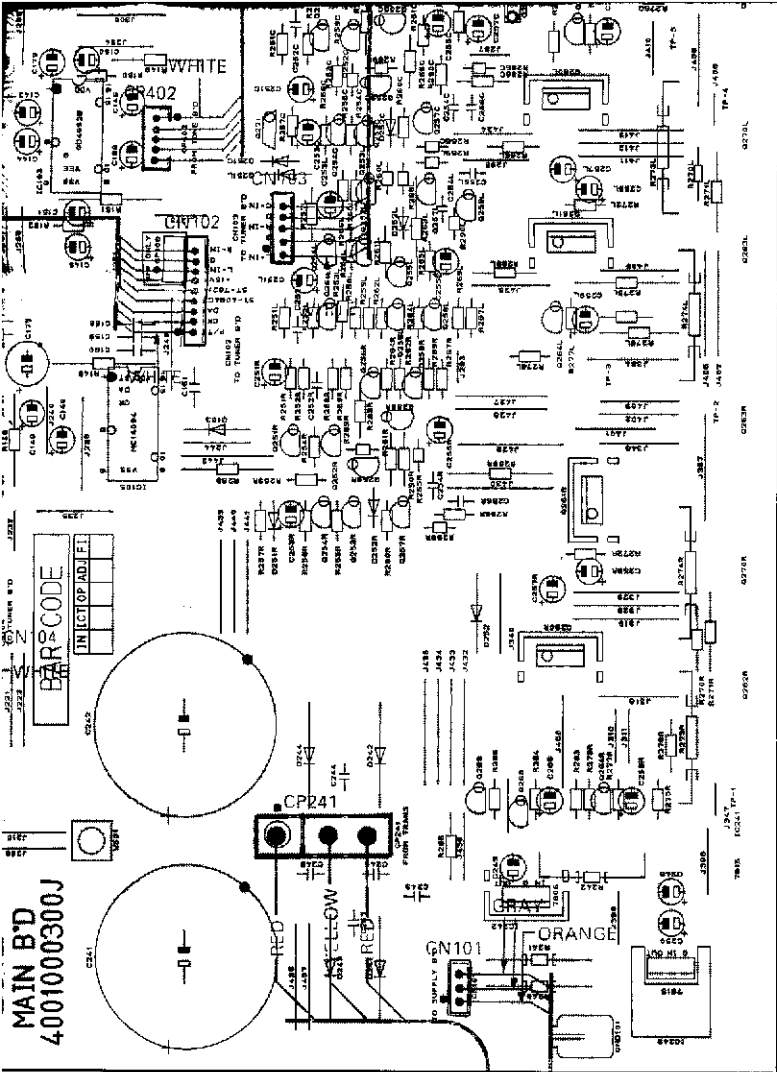

CP701

120 V	230 V
BLACK	ORANG
BLUE	YELLOW

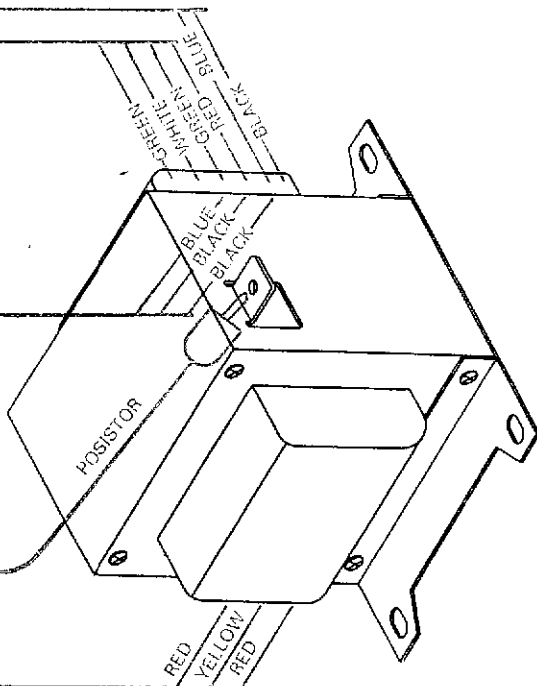

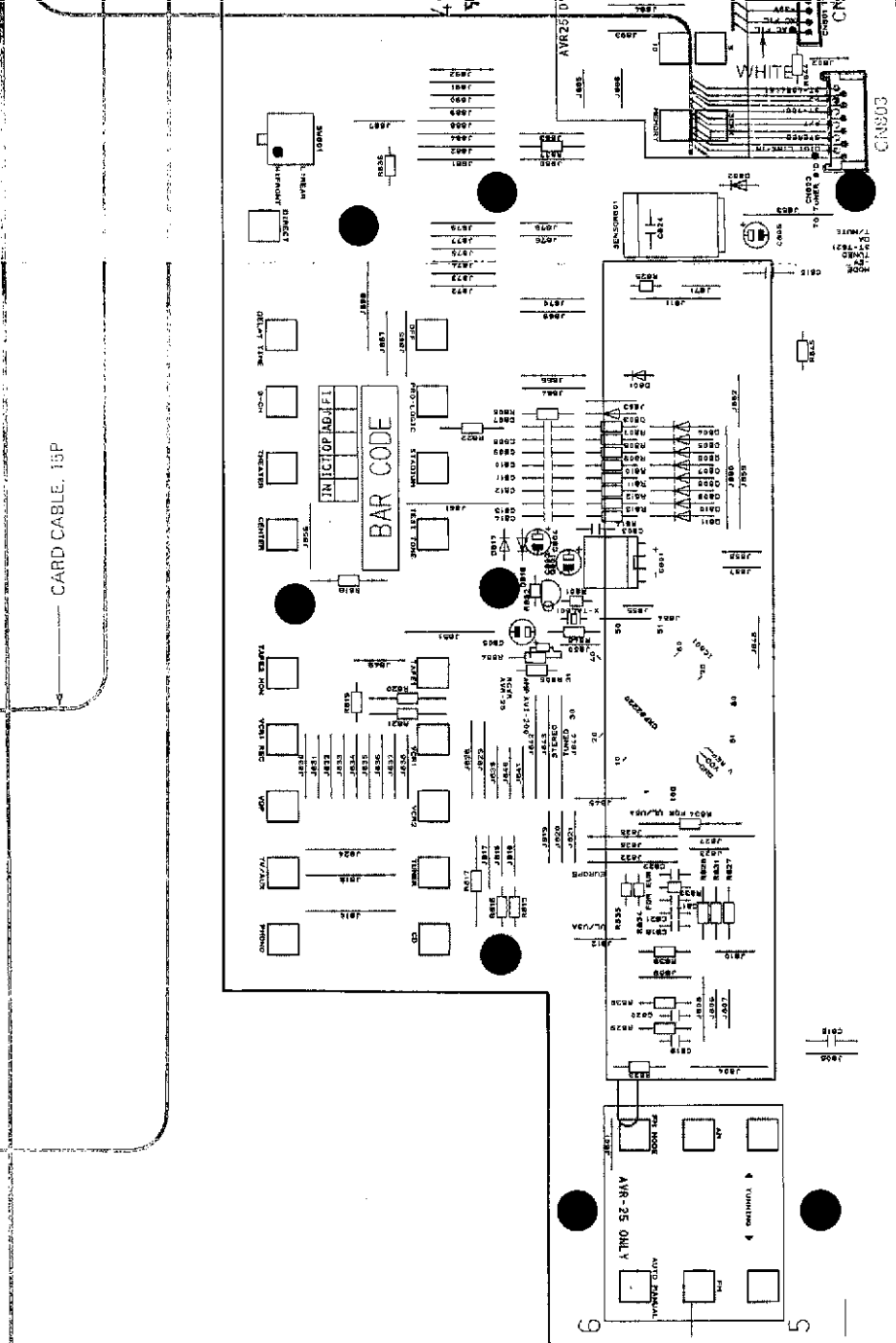
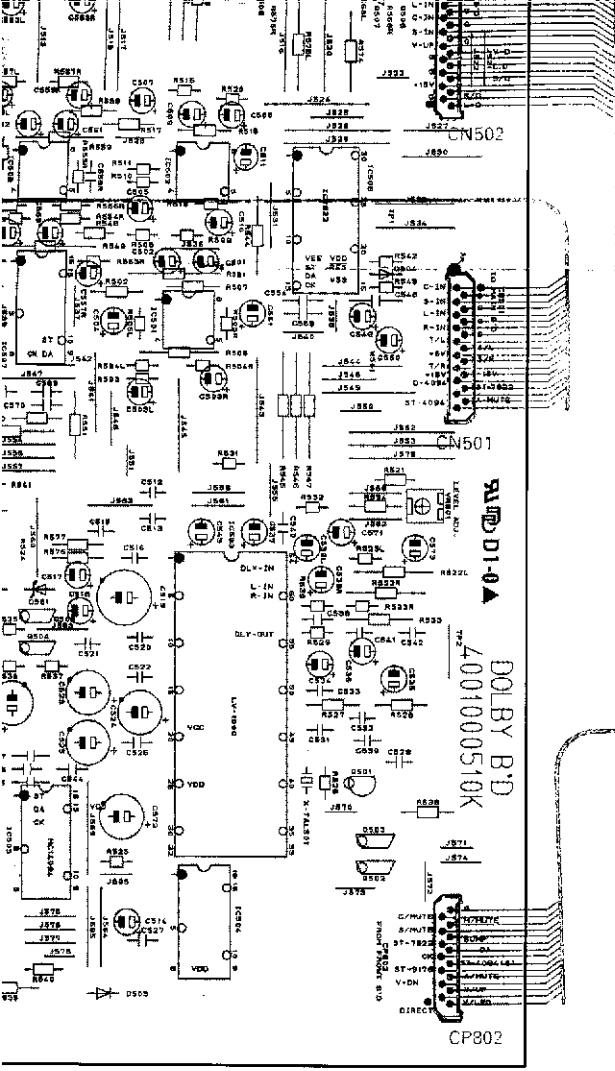

8



PCB9

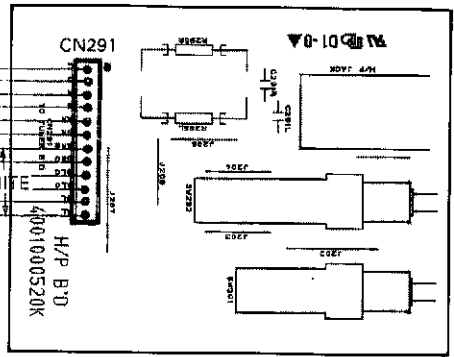

PCB6

